

# DSS-13 S-/X-Band Microwave Feed System

F. Manshadi

Ground Antennas and Facilities Engineering Section

*The configuration, detail design, and performance of the dual S-/X-band microwave feed system for the new DSN beam-waveguide antenna, Deep Space Station (DSS) 13, are reported. By using existing spare components, reducing fabrication cost of new components by simplifying their design, and using new fabrication techniques and material, this DSS-13 feed system was implemented successfully with a small budget and a very tight schedule. Measured noise temperature gains of the feed system are 17.5 K for S-band (2200–2300 MHz) and 24.0 K for X-band (8200–8600 MHz), which agree very closely with the predicted performance.*

## I. Introduction

DSS 13, located at the Deep Space Communications Complex in Goldstone, California, is NASA's first beam-waveguide tracking antenna. This antenna, which is primarily used for research and development tasks, is an elevation-over-azimuth type using wheel and track azimuth bearings.<sup>1</sup> DSS 13 has a parabolic main reflector and a hyperbolic subreflector that are 34 and 3.43 m in diameter, respectively. The subreflector is supported by a low-optical cross-section tripod. The main reflector and the subreflector are both shaped to provide near-uniform aperture illumination [1]. The reflector surfaces are de-

signed and fabricated for providing high performance at 32 GHz.

In beam-waveguide antennas, the microwave front-end equipment is placed in a large room, called the pedestal room, under the main reflector structure. The microwave signal is guided from the pedestal room to the subreflector, or vice versa, through a system of flat or curved reflectors (see Fig. 1). There are several advantages to having the microwave feed equipment in the pedestal room: the microwave equipment will be stationary at all times; installation and maintenance are made easier; and there is the capability of using several feed systems without introducing additional loss due to the blockage.

At DSS 13, a large rotatable elliptical reflector in the basement (M5) and two flat and two parabolic reflectors

<sup>1</sup>M. Britcliffe, ed., *DSS-13 Beam-Waveguide Antenna Project: Phase 1 Final Report*, JPL D-8541 (internal document), Jet Propulsion Laboratory, Pasadena, California, May 15, 1991.

in the beam-waveguide tube (M1 through M4) are used to guide the signal to the subreflector. Several different microwave feed systems are placed about the rotating ellipsoid. Each microwave feed can then be selected remotely by aligning the ellipsoid in the direction of that feed.

This article describes the S-/X-band feed system implemented for DSS 13. Section II covers the general theory of the operation of the feed system; Section III describes the detail design; and Section IV describes the performance. To reduce the cost of this task, attempts have been made to maximize the utilization of existing spare or decommissioned microwave components.

## II. S-/X-Band Feed System Theory of Operation

The DSS-13 S-/X-band microwave feed system is capable of receiving S- and X-band signals simultaneously. Figure 2 shows the main components of this feed system: the X-band feed, the S-band feed, the S-/X-band dichroic reflector, and the X-band flat reflector. The S-band receiving frequency band is 2200 to 2300 MHz, and the X-band receiving frequency band is 8200 to 8600 MHz.

The S-band signal received from space is collected by the main- and sub-reflectors and is focused at F1 (see Fig. 1). Reflectors M1 through M4 guide the signal to the rotating ellipsoid focus F2. The signal is then scattered off the ellipsoid mirror, reflected by the dichroic reflector, and focused at the other focal point of the elliptical mirror. This signal is received by the S-band feedhorn in the S-band feed package.

The X-band signal is guided by the beam waveguide to the basement in the same manner as the S-band signal. However, after scattering off the ellipsoid, it passes through the dichroic mirror with very little loss, is reflected by the X-band flat reflector, and is focused at the other focal point of the ellipsoid. This signal is received by the X-band feedhorn in the X-band package.

## III. Detail Design

A block diagram of the S-/X-band feed packages is shown in Fig. 3. The low-noise amplifier (LNA) used in this package was obtained from the decommissioned 26-m antenna at DSS 13. This is a dual-frequency LNA (i.e.,

it contains an X-band LNA and an S-band LNA in one cryogenic package). The S- and X-band feeds are packaged separately; however, they are physically connected since they share the same LNA package. The feedhorns are corrugated with the same corrugations and flare angle as the standard JPL feedhorns. The gain of the feedhorns is 19.1 dB for S-band and 25.0 dB for X-band. The polarizers provide the capability to select right-hand circular polarization (RCP) or left-hand circular polarization (LCP) reception. In the S-band package, the position of the polarizer can be changed easily by the use of the rotary joints; but in the X-band package, the position of the polarizer is fixed. To change polarization on the X-band, the polarizer has to be unscrewed and then rotated; however, spacers have been supplied to allow the addition of rotary joints at a future date. The couplers are used for injection of noise to check the linearity of the LNAs. The waveguide switches are used to connect the LNAs to the feedhorns or to the ambient loads for noise temperature and linearity measurements.

The S-/X-band dichroic reflector is a frequency-selective surface that passes the X-band signal but reflects the S-band signal. The S-/X-band dichroic plate used at DSS 13 is a 198.1-cm  $\times$  141.5-cm  $\times$  3.576-cm rectangular aluminum plate with an elliptical perforated area (see Fig. 4). The holes in the perforated area are based on an old dichroic plate design [2]. This design employs the Pyleguide holes originally used by Pyle [3]. However, to reduce the fabrication cost, the corner radius of the holes was increased from 0.013 to 0.318 cm, as shown in Fig. 4. An analysis of the propagation constant of the fields in the Pyleguide holes shows that the change in the propagation constant due to this modification is far less than the change due to the tolerances of the other critical dimensions of the holes.<sup>2</sup> This minor change reduced the fabrication cost of the S-/X-dichroic reflector by more than 60 percent.

The frames for the S- and X-band packages were fabricated using Bosch extruded aluminum struts. These struts are prefabricated, strong, lightweight, and flexible. Their anodized aluminum surface finish is scratch and corrosion resistant. Since all the elements of the frames are bolted together, it is very easy to modify these frames as needed in the future. The use of these materials resulted in a cost savings of more than 50 percent compared to conventional welded steel framing.

<sup>2</sup> J. C. Chen and P. H. Stanton, "Effect of Corner Radius on the Performance of an S-/X-Band Dichroic Plate With Pyleguide Aperture," JPL Interoffice Memorandum 3327-92-078 (internal document), Jet Propulsion Laboratory, Pasadena, California, November 24, 1992.

Figure 5 shows the S- and the X-band microwave feed assemblies and their overall dimensions.

#### IV. Feed System Performance

The preliminary predicted and measured noise temperatures of the S-/X-band LNAs, microwave feeds, and the overall DSS-13 beam-waveguide antenna are given in Table 1. The higher noise temperature measured for the X-band LNA is due to the age of that package and cannot be improved easily. The predictions are calculated from the theoretical or measured loss of the individual component of each system. The measurement data for the

feeds were made at Goldstone before installation in the antenna pedestal room. The measurements for the overall antenna were made after the feed packages were installed and aligned in the pedestal room.

#### V. Conclusion

The DSS-13 feed system was implemented successfully with a small budget and a very tight schedule. This was accomplished by using existing spare components, reducing fabrication cost of the new components by simplifying their design, and using new fabrication techniques and material. The measured and predicted performance of the feed systems and the overall antenna agree closely.

### Acknowledgments

This task owes its successful completion to the teamwork and dedication of the people who were involved. Many people from different organizations have made valuable contributions by offering their expertise and hard work. In particular, the author would like to acknowledge M. Esquivel for RF and optical design; J. Chen and P. Stanton for dichroic plate analysis; T. Otsoshi, M. Franco, and S. Stewart for feed and antenna measurements; J. Fernandez and J. Loreman for repair and testing of the S-/X-band LNA; D. Ball, R. Bryant, and D. Ohashi for mechanical design; and M. Gatti for funding support.

### References

- [1] D. A. Bathker, W. Veruttipong, and P. W. Cramer, "Beam-Waveguide Antenna Performance Predictions with Comparison to Experimental Results," *IEEE Transactions on Microwave Theory and Technology*, vol. 40, no. 6, pp. 1274–1285, June 1992.
- [2] P. D. Potter, *Improved Dichroic Reflector Design for the 64-Meter Antenna S- and X-Band Feed Systems*, JPL Technical Report 32-1526, vol. XIX, Jet Propulsion Laboratory, Pasadena, California, pp. 55–62, February 15, 1974.
- [3] J. R. Pyle, "Cutoff Wavelength of Waveguides with Unusual Cross Sections," *IEEE Transactions on Microwave Theory and Technology*, vol. MTT-12, no. 5, pp. 556–557, September 1964.

**Table 1. Noise temperature predictions and measurements.<sup>a</sup>**

System	S-band predictions, K	S-band measurements, K	X-band predictions, K	X-band measurements, K
LNA	8.3	8.72	12.0	14.09
Feed	17.69	17.5	23.07	25.5
Antenna	37.26	38.0	32.90	35.5

<sup>a</sup> Values are not corrected for weather.

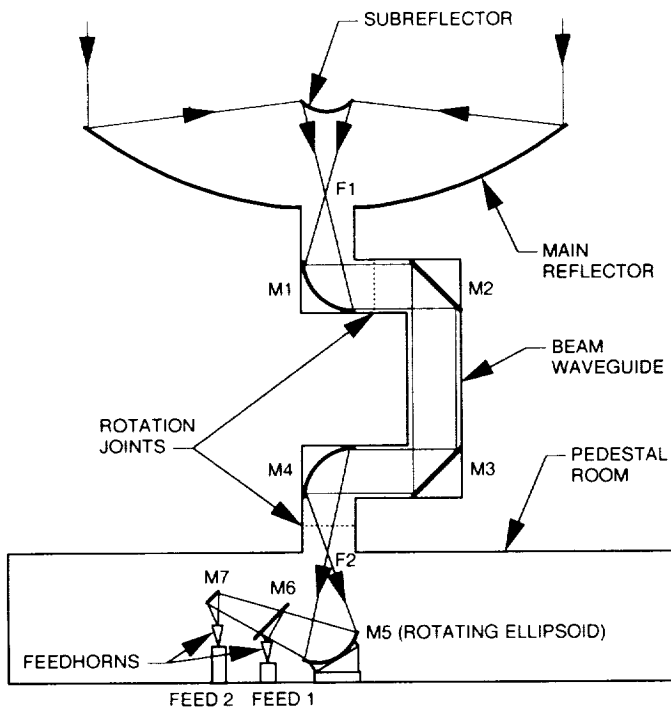

**Fig. 1. The DSS-13 beam-waveguide antenna configuration.**

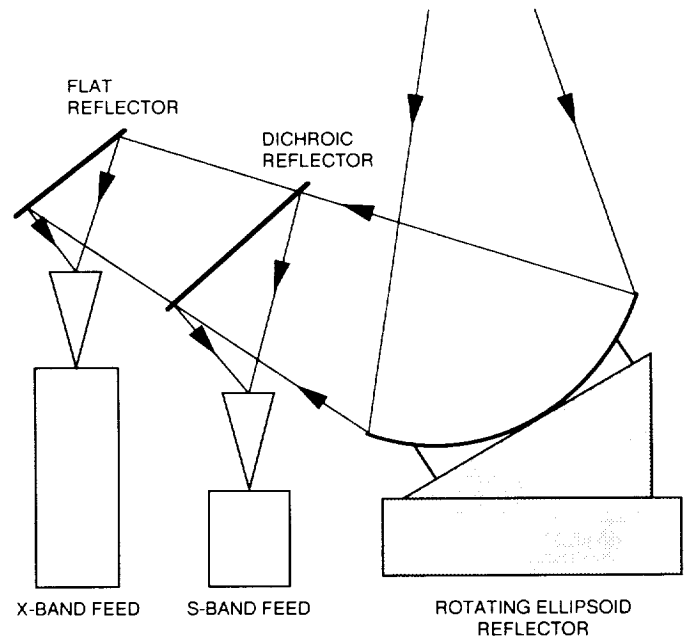

**Fig. 2. The DSS-13 S-/X-band microwave feed system.**

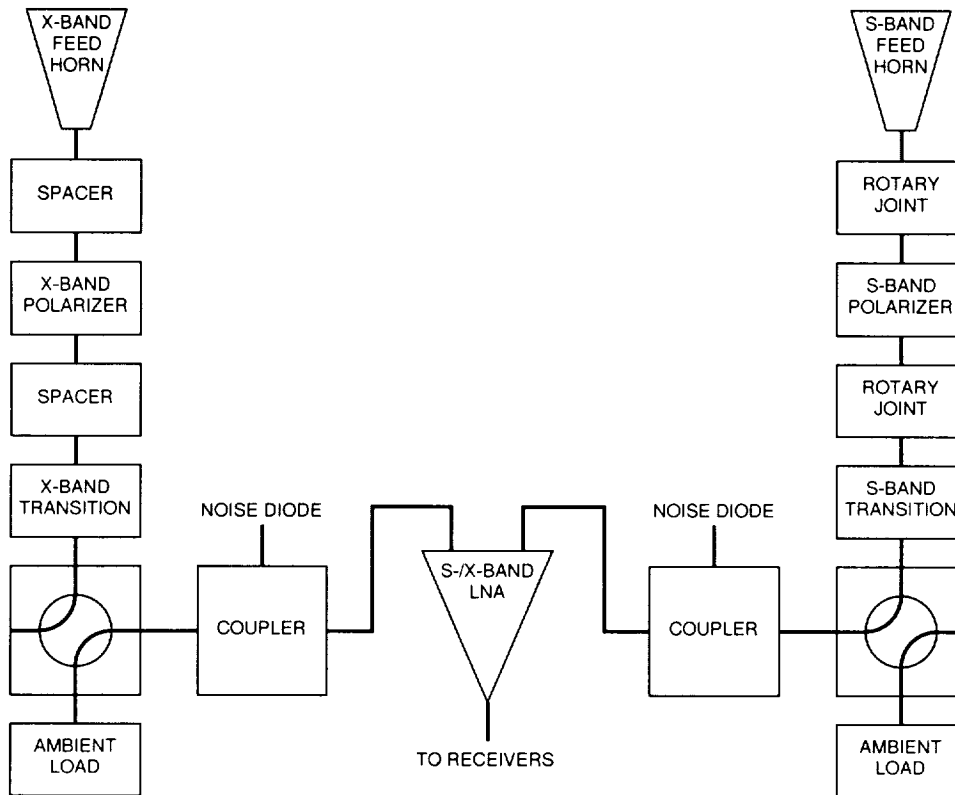

Fig. 3. The DSS-13 S-/X-band microwave feed block diagram.

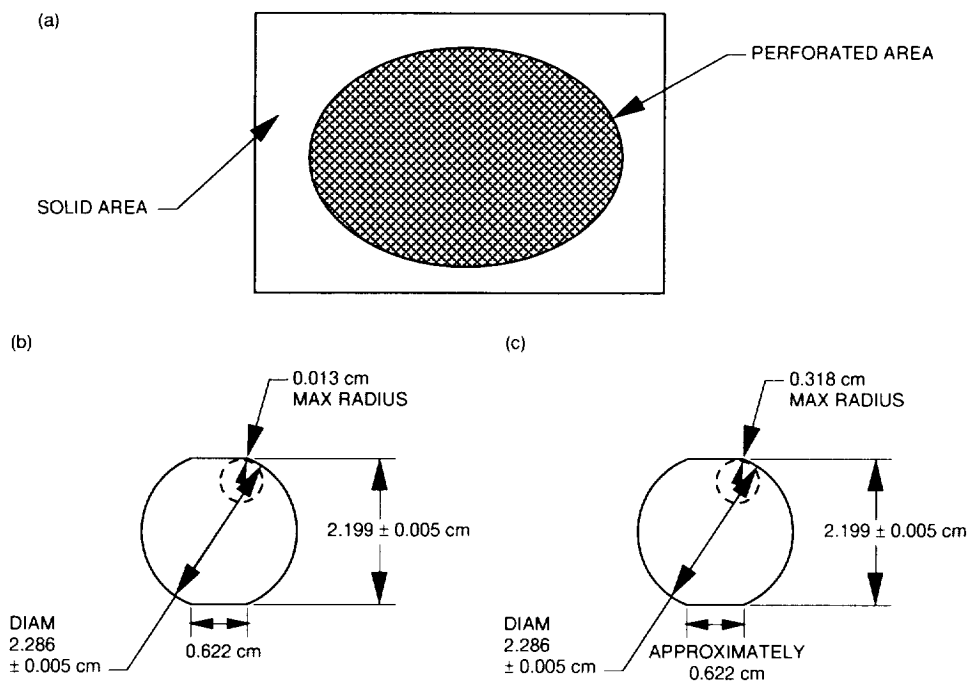

Fig. 4. The DSS-13 S-/X-band dichroic reflector: (a) aluminum plate with an elliptical perforated area; (b) original Pyleguide design; and (c) modified Pyleguide design.

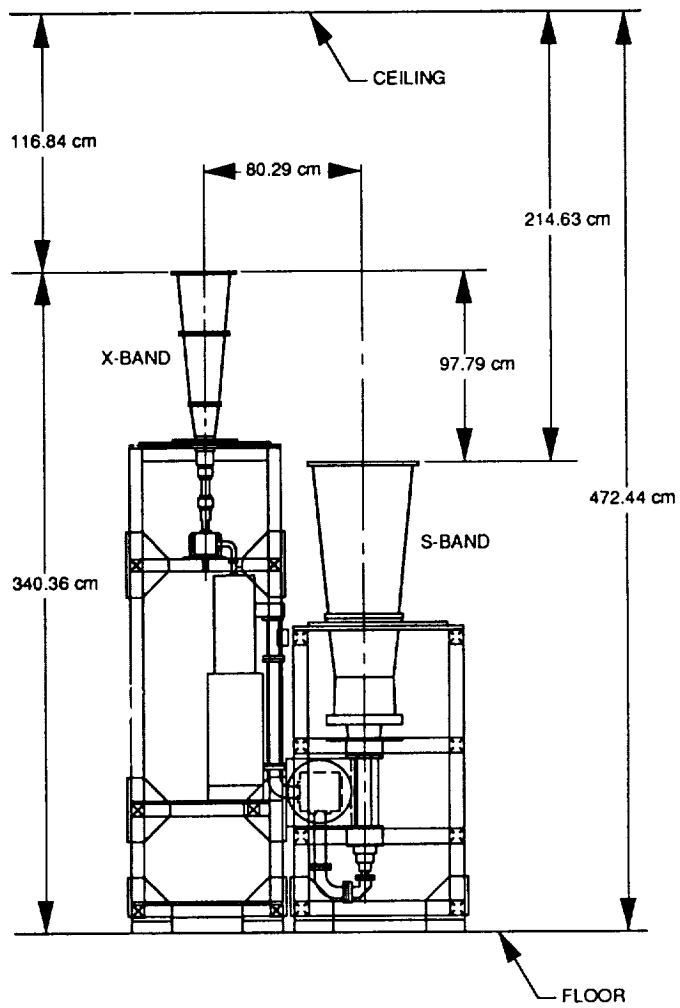

Fig. 5. The S- and X-band microwave feed assemblies.