

## AEROSPACE APPLICATIONS OF MAGNETIC BEARINGS

James Downer, James Goldie, Vijay Gondhalekar, and Richard Hockney  
SatCon Technology Corporation  
Cambridge, Massachusetts

### ABSTRACT

Magnetic bearings have traditionally been considered for use in aerospace applications only where performance advantages have been the primary, if not only, consideration. Conventional wisdom has been that magnetic bearings have certain performance advantages which must be traded off against increased weight, volume, electric power consumption, and system complexity. These perceptions have hampered the use of magnetic bearings in many aerospace applications because weight, volume, and power are almost always primary considerations.

This paper will review progress on several active aerospace magnetic bearing programs at SatCon Technology Corporation. The magnetic bearing programs at SatCon cover a broad spectrum of applications including:

- (1) a magnetically-suspended spacecraft integrated power and attitude control system (IPACS)
- (2) a magnetically-suspended momentum wheel
- (3) magnetic bearings for the gas generator rotor of a turboshaft engine
- (4) a vibration-attenuating magnetic bearing system for an airborne telescope
- (5) magnetic bearings for the compressor of a space-rated heat pump system

The emphasis of these programs is to develop magnetic bearing technologies to the point where magnetic bearings can be truly useful, reliable, and well tested components for the aerospace community.

- **SatCon has three current programs involving magnetic bearings, two in fabrication/testing stage, one in final design.**
  
- **Usual disadvantages:**
  - More expensive hardware**
  - Complicated controller**
  - Backup bearings**
  
- **Usual advantages of magnetic bearings:**
  - Vibration control**
  - No lubrication**
  - High speed**
  - No wear**
    - Extended life**
    - Less heat**

## **THE FREON COMPRESSOR (PHASE II, SDIO)**

- **Rationale:** Heat pump/thermal management system shown to be more efficient in reducing mass and radiation area.
- **Goal:** Develop with Mainstream Engineering, integrated freon heat pump capable of 5 year lifetime.
- **Sensors, actuators, and auxiliary bearings integrated in a small package with a high-speed induction motor.**
- **Design Specifications:**
  - Operating speed: 24 krpm
  - Rotor mass:  $\approx 5$  kg
  - Overall mass: 15 kg
  - Required motor output: 7 hp
  - Rotor 1<sup>st</sup> flexible mode > 500 Hz
  - Environmental conditions:
    - Temperature Range: 230 K - 400 K
    - Magnetic bearing loads up to 2 g's + Compressor Axial load
  - Components must operate in Freon 113

- Schematic of system:

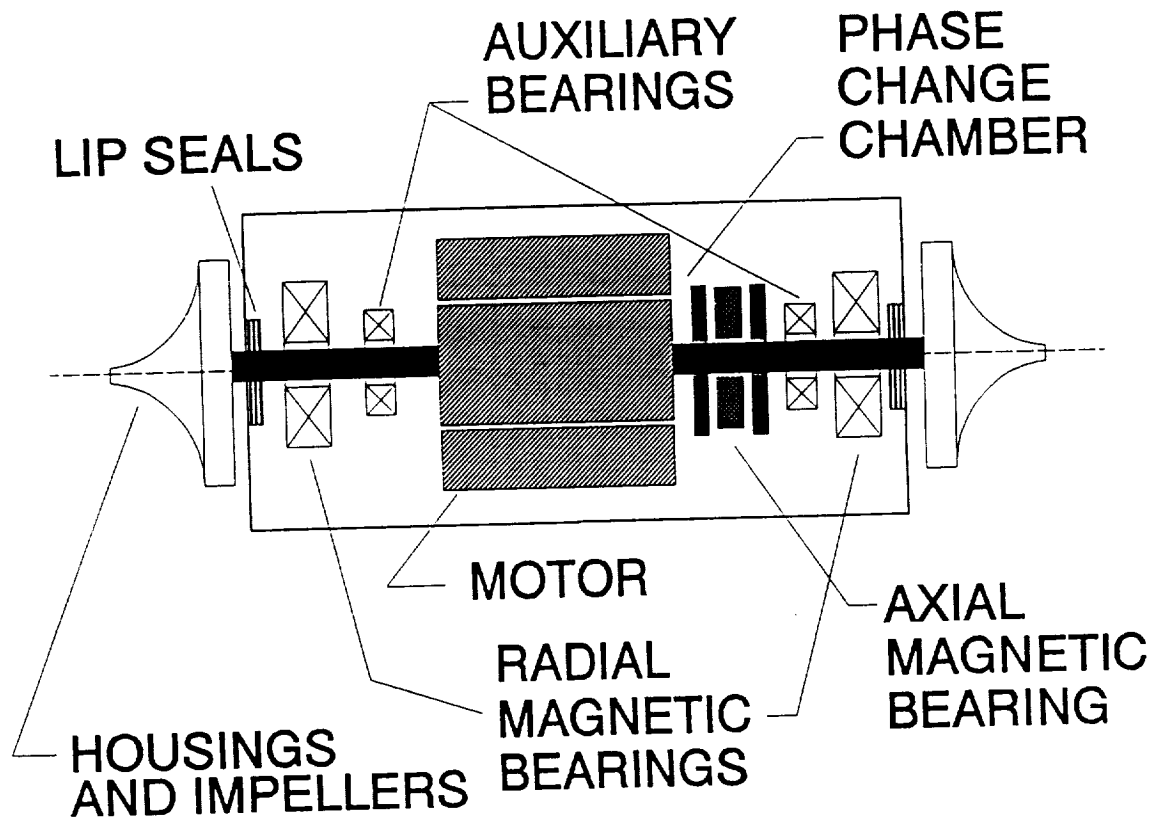

Freon Compressor Schematic

- Two radial bearings and one axial bearing.
- Bearing geometry dictated by flexural consideration.

## BEARING ACTUATOR

### Radial

- Real time force control requirements: 2 g of shaft acceleration for both the radial and thrust systems and capability of the thrust bearing to compensate the thrust load from the compressor (450 N)
- Separated bias and control coils: reduces power amplifier number to four and single bias supply.

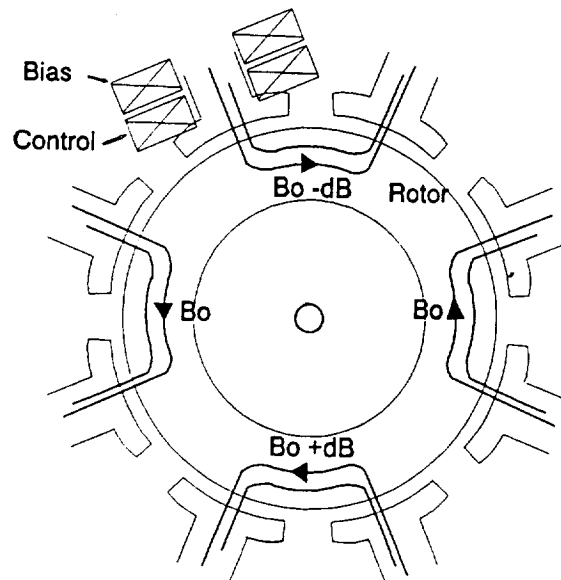

Magnetic configuration of eight pole radial bearing showing flux paths and coil arrangement.

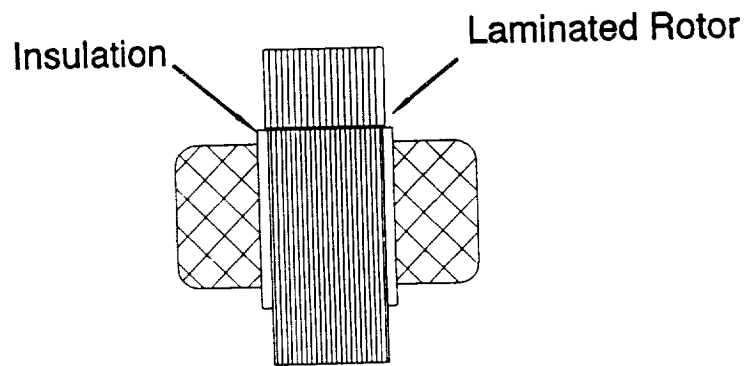
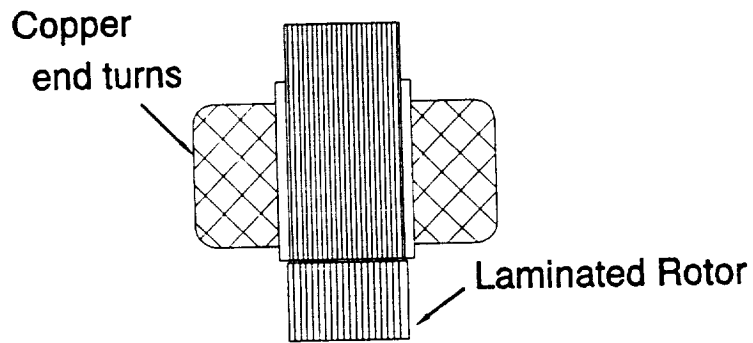

Radial actuator side view to scale.

## Thrust

- Require 450 N bi-directional with  $\pm 2g$  superimposed
- Startup requirement mandates ramping capability under closed loop control.
- Geometry: dual rotor/single geometry (fewer components and less V-A capability but greater mass)
- P-M Magnetic Bias.
- Un-laminated. Core losses acceptable.

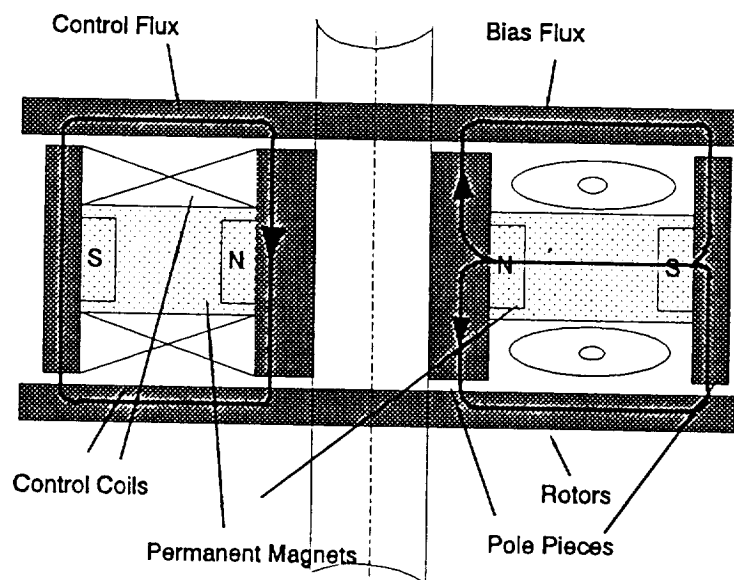

Permanent magnet biased geometry for thrust actuator with flux paths indicated.

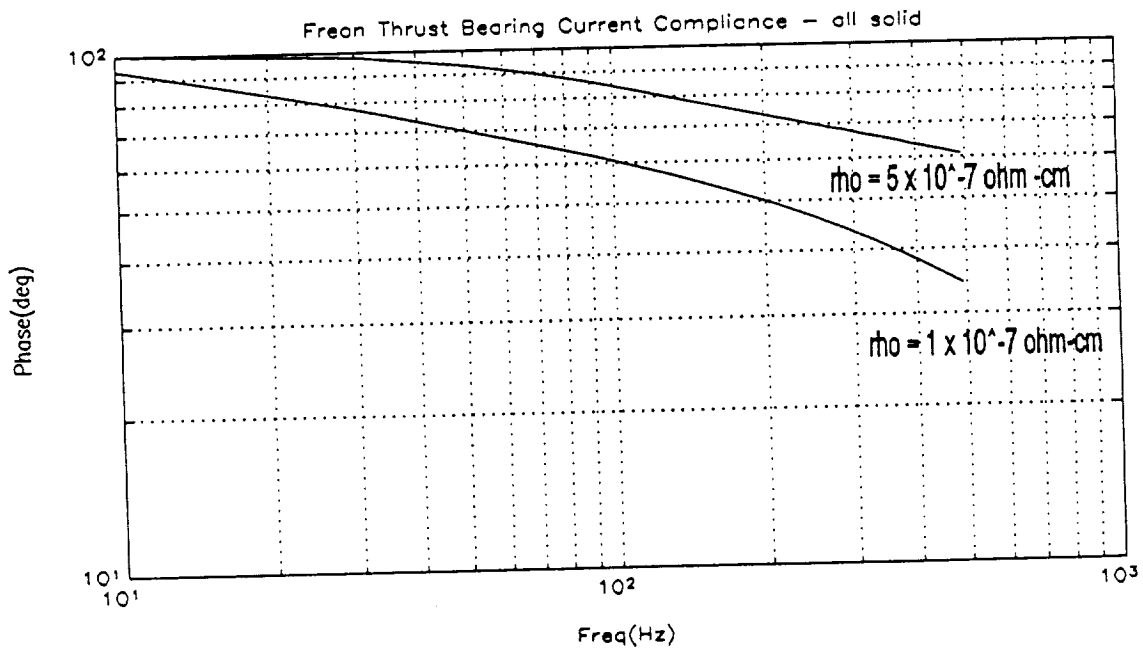
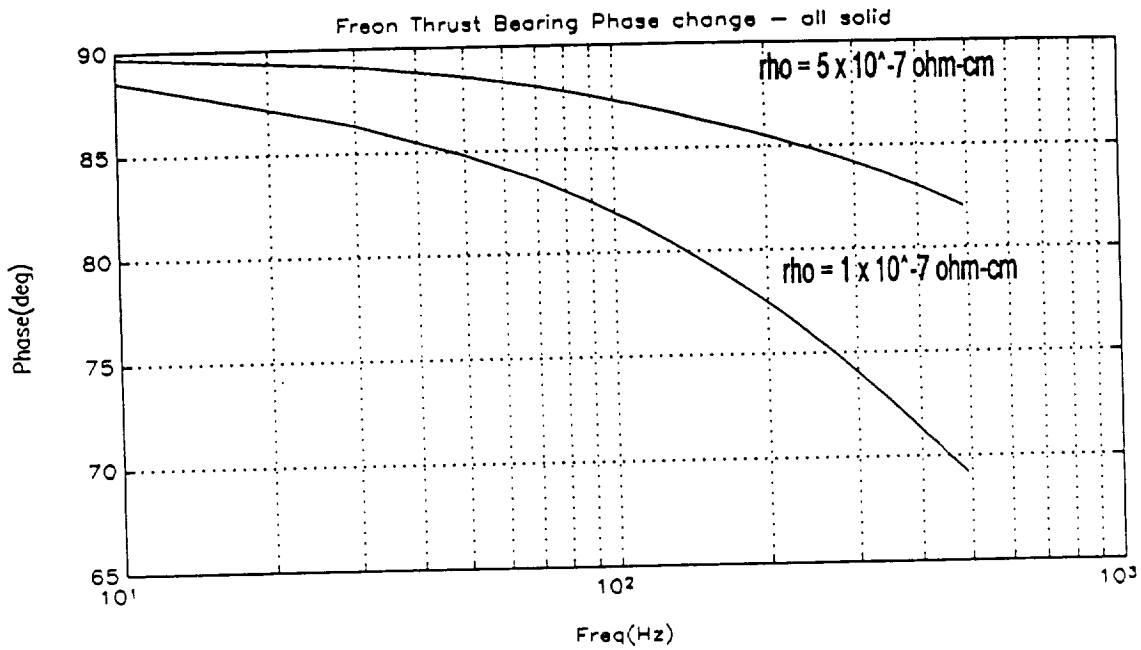

Phase and compliance as a function of frequency for axial actuator. The two curves are for different core resistivities.



- Precision journals on center shaft as targets for the radial inductive sensors.
  
- Unit is designed to run in zero-g; it must be tested with the shaft oriented both vertically and horizontally.
  
- Auxiliary Bearings:
  - Momentary support during failures and startup.
  - Two sets of duplex angular contact bearings integrated into the end housings and pre-loaded.
  - Unlubricated, since incompatible with Freon 113

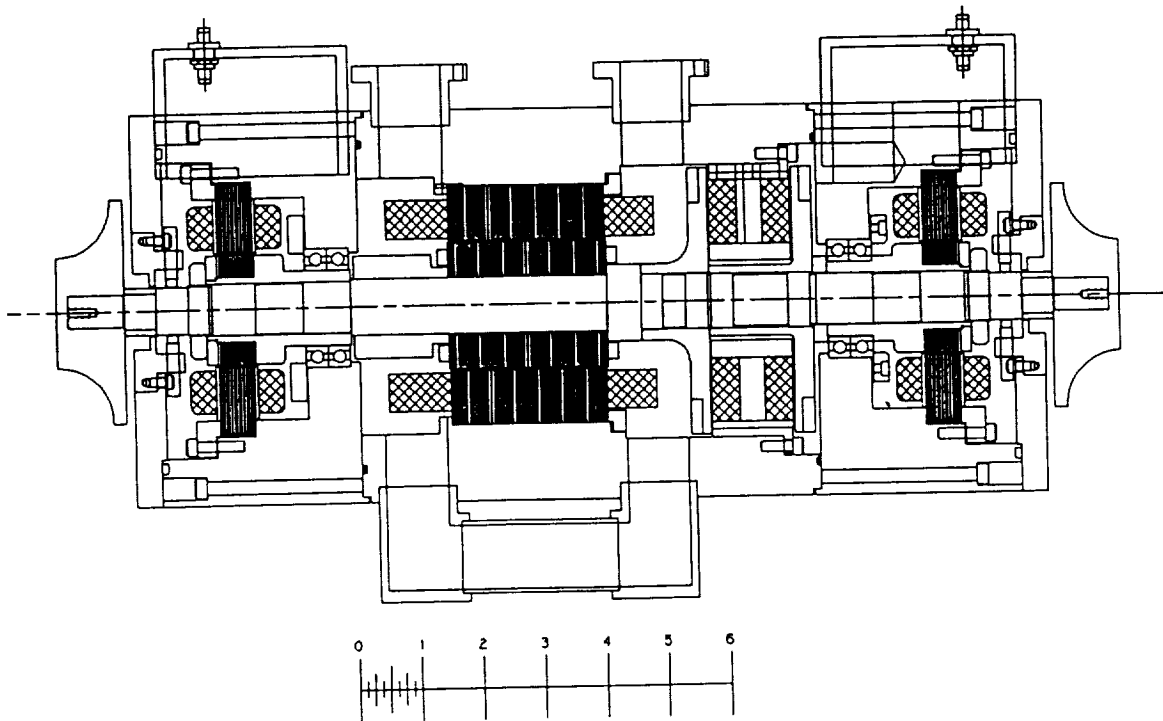

Complete compressor showing positions of magnetic bearing actuators.

### Status

- Thrust loop has been closed.
- One directional radial loop shakedown underway, non-zero bias from complementary actuators complicates testing.
- Compressor impellers not yet designed.

## **MOMENTUM WHEEL (SBIR PHASE II, NASA, GODDARD)**

- **Rationale:** Vibrations of momentum wheel bearings in spacecraft degrade instrument and pointing performance.
- **Standard Approaches:** Design structure to separate modal from vibrational frequencies, minimize residual mass imbalance, passive isolators.
- **Alternately:** Use magnetic bearings to eliminate vibrations and mass imbalance by use of bearings with programmable compliance.
- **Goals:** Design and fabricate magnetically suspended momentum wheel and test for operation in 1g ground experiment.

## **SPECIFICATIONS**

### **Base line TELDIX DR-68 momentum wheel**

<b>Momentum</b>	<b>68 Nms (92.2 ft-lb) at 6000 rpm</b>
<b>Speed range</b>	<b>3500 - 6600 rpm</b>
<b>Inertia</b>	<b>0.1082 kgm<sup>2</sup></b>
<b>Run Up time</b>	<b>19 min (1140 sec)</b>
<b>T<sub>min</sub> (designed)</b>	<b>0.06 Nm</b>
<b>T<sub>min</sub> (measured)</b>	<b>0.092 Nm</b>

### **Critical design criteria for SatCon Momentum Wheel**

<b>Nominal op. speed</b>	<b>6000 rpm</b>
<b>Nominal Stored Momentum</b>	<b>68 Nms at 6000 rpm</b>
<b>Motor Peak Torque</b>	<b>0.1 Nm</b>
<b>Maximum bus power available</b>	<b>120 W</b>
<b>Torque for precessing wheel</b>	<b>0.57 Nm</b>

## DESIGN ISSUES AND QUALITATIVE GUIDELINES

- **Must operate in 1 g**
- **Spins about inertial axis**
- **Concentrate mass at periphery to maximize inertial**
- **Touchdown bearings fabricated with conventional technology**
- **Magnetics with overcapacity in terms of forcing and torquing**
- **Actuators to utilize large lever arms for precessional torque**
- **Sensor gaps measured at pole faces (collocated).**

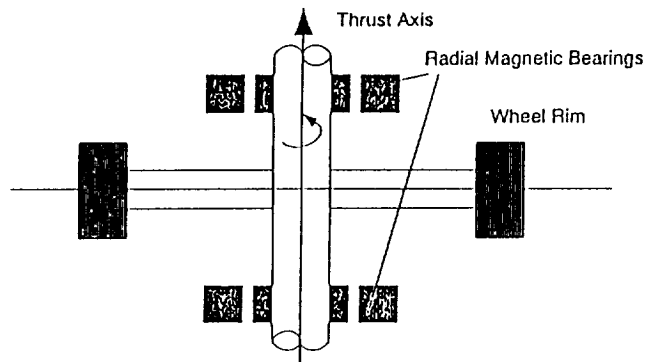

*Active Radial Control. Passive Thrust Control*

**OPTION A**

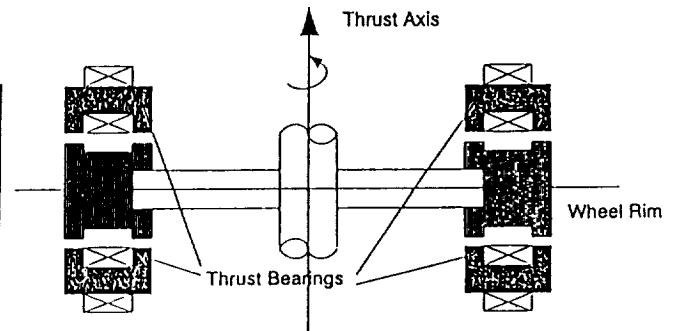

*Active Thrust Control. Passive Radial Control*

**OPTION B**

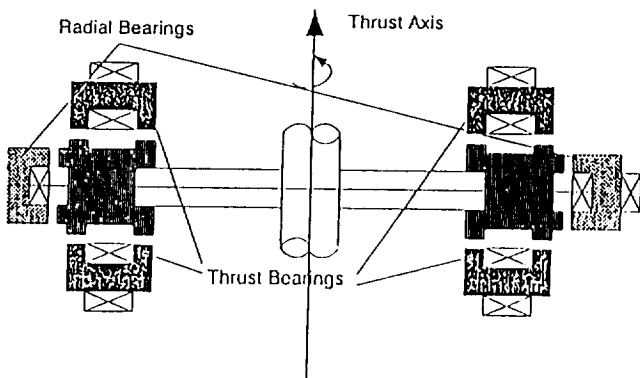

**OPTION C**

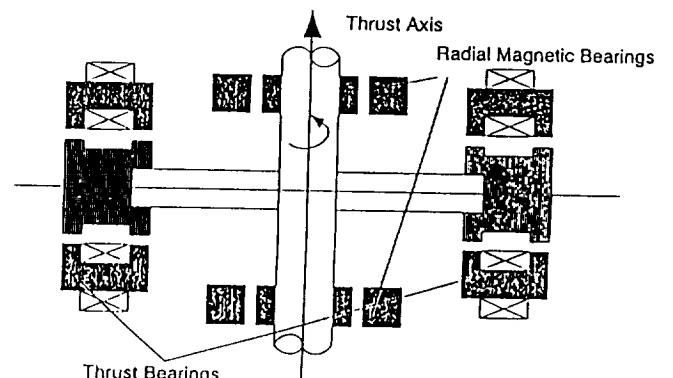

**OPTION D**

**Alternate Magnetic Bearing Actuator Configurations in Momentum Wheel.**

## ACTUATOR GEOMETRY

- Four bearings at periphery for torques ( $\tau_x$ ,  $\tau_y$ , and forces  $F_z$ )
- Radial bearing at hub ( $F_x$ ,  $F_y$ )
- Non-laminated.
- Drive motor at center of hub

## MECHANICAL DESIGN

- Rotor
- Housing structure
- Inertial rings
- Bearing actuators
- Motor drive

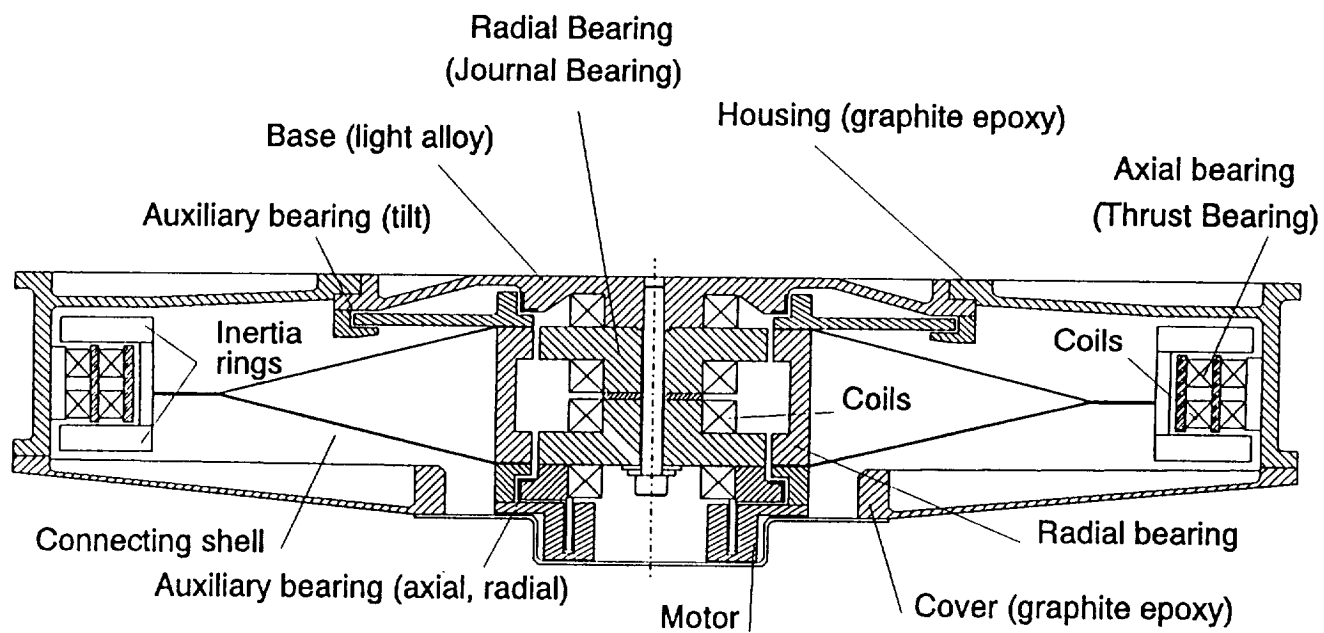

Thrust and radial bearing placement in the low noise momentum wheel design

- Touchdown surfaces:

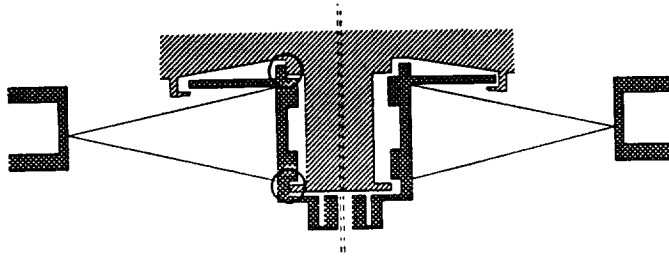

Radial Touchdown

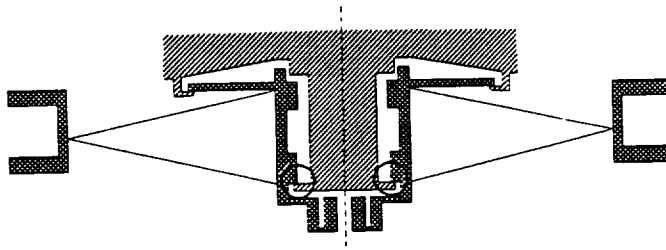

Axial Touchdown

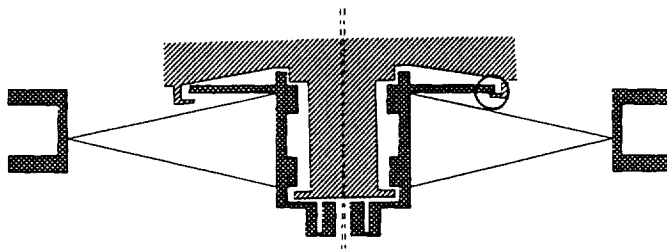

Tilt Touchdown

#### Auxiliary Bearing Operation

- Use 'Vespel' (DuPont) - dimensional stability, low friction, high PV limit.



- **Stress loading at 6000 RPM:**

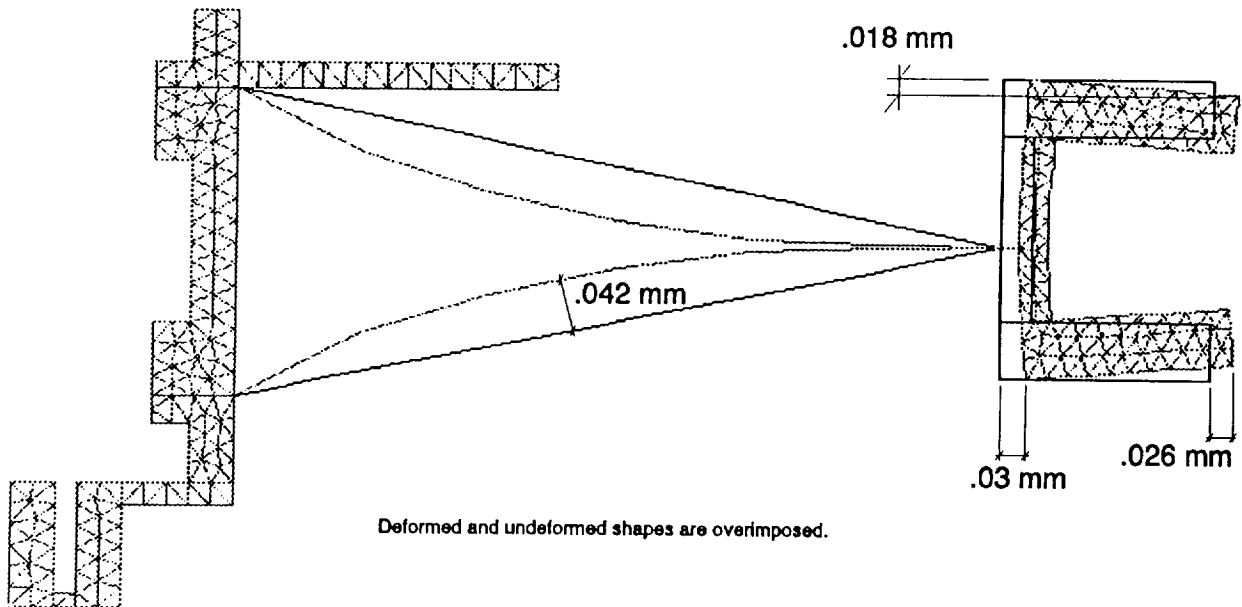

- **Deformation of the Rotor Under Centrifugal Loading**
- **Thrust Sensors Operate in Pairs to Reject Common Mode Signals**

## MAGNETICS DESIGN

- **Axial Bearing: 80 N, maximum, 0.6 N-m**

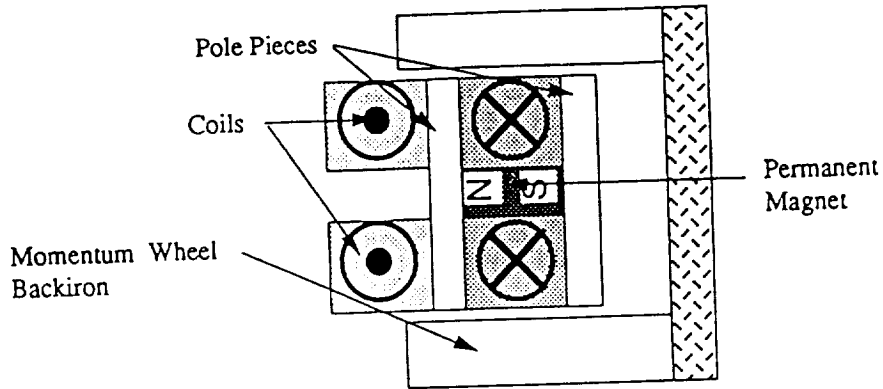

### Thrust Actuator Configuration

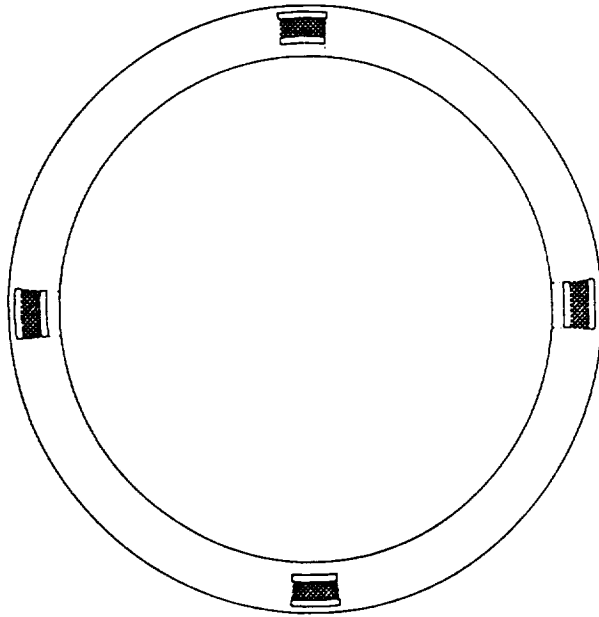

### Thrust Actuator Location

- Radial Bearing Actuator: 80 N max, Bias at .26 T, 400 A-T/coil, Tandem Sets of Four Poles

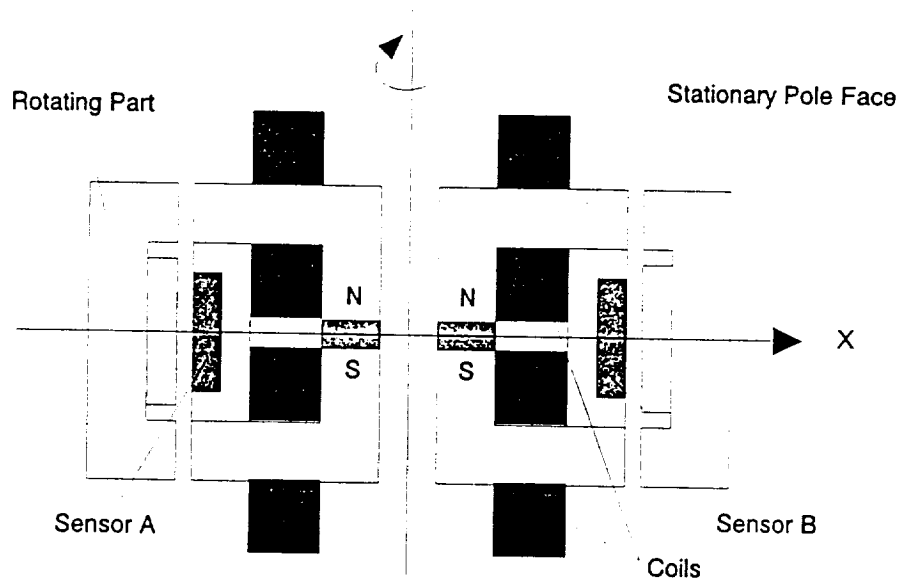

Radial bearing gap measurement with 2 sensor heads

- **Torque Motor: Lorentz Force, 0.1 N/m, 3-phase, Ironless Armature, 4-pole**

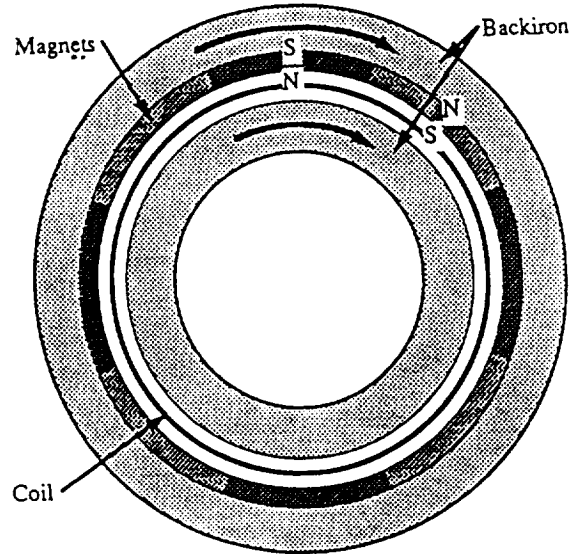

### Torque Motor Configuration

### CONTROLLER IMPLEMENTATION

- **Designed to compensate for mass unbalance (rotation around mass center vs. geometric center)**
- **Elimination of synchronous disturbances**

## CONCLUSIONS

	<b>TELDIX DR-68 Momentum Wheel</b>	<b>SatCon Low Vibration Momentum Wheel</b>
<b>Total Mass</b>	8 Kg	8.3 Kg
<b>Dimensions</b>	350 mm Diameter 120 mm Height	384 mm Diameter 88 mm Height
<b>Steady State Power</b>	< 26.5 Watts	< 10 Watts in 1g < 5 Watts in 0g
<b>Maximum Wheel Precession Rate</b>	-	0.03 rad/sec in 1g 0.08 rad/sec in 0g (min required $7.6 \times 10^{-3}$ )
<b>Torque Vibration at GOES spacecraft mass center</b>	Forces at 6000rpm with 0.75 gm cm residual static imbalance $F = 4.7 \text{ N}$  Measured at 6000rpm $T_x = 7.46 \text{ Nm}$ $T_y = 6.83 \text{ Nm}$ $T_z = 7.46 \text{ Nm}$	Forces at 6600 rpm assuming 0.75 gm cm static imbalance $F = 0.27 \text{ N}$  Simulated including measurement error  $T_x = T_y = T_z < 0.7 \text{ Nm}$

### **MAGNETICALLY-SUSPENDED SPACECRAFT INTEGRATED POWER AND ATTITUDE CONTROL SYSTEM (SBIR PHASE II, NASA, MARSHALL).**

- **Rationale:**

Spacecraft utilizing solar power generation use batteries as energy storage elements.

Flywheel Storage: Potentially longer operational life-time, lower maintenance requirements, higher energy densities, and peak power capability.

- **Goal:**

Integration of all current technology advances into working model.

Design, build, and evaluate system capable of 2 kW-hr at 40 W-hr/kg and 2 kW and charge/discharge efficiency greater than 85% all in 1 g.

- Schematic of Fabricated Device:

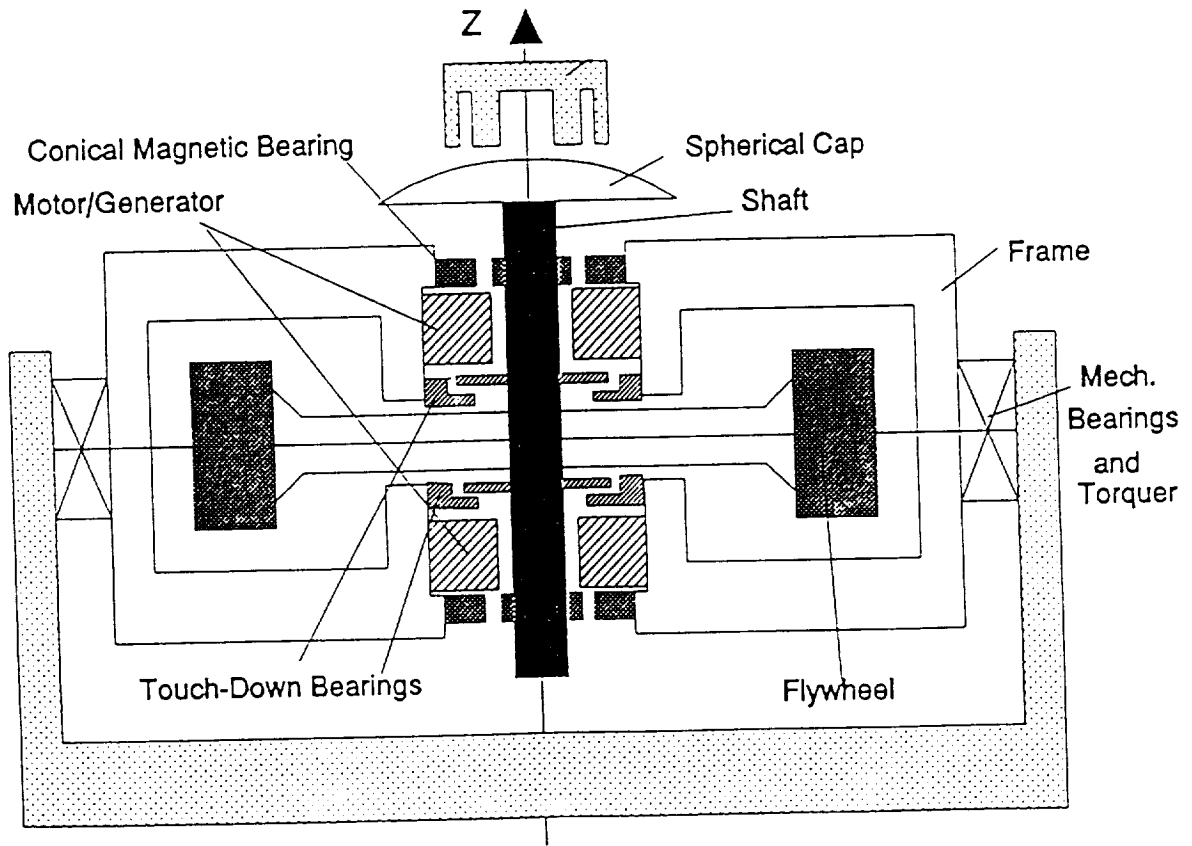

- Actual Geometry:

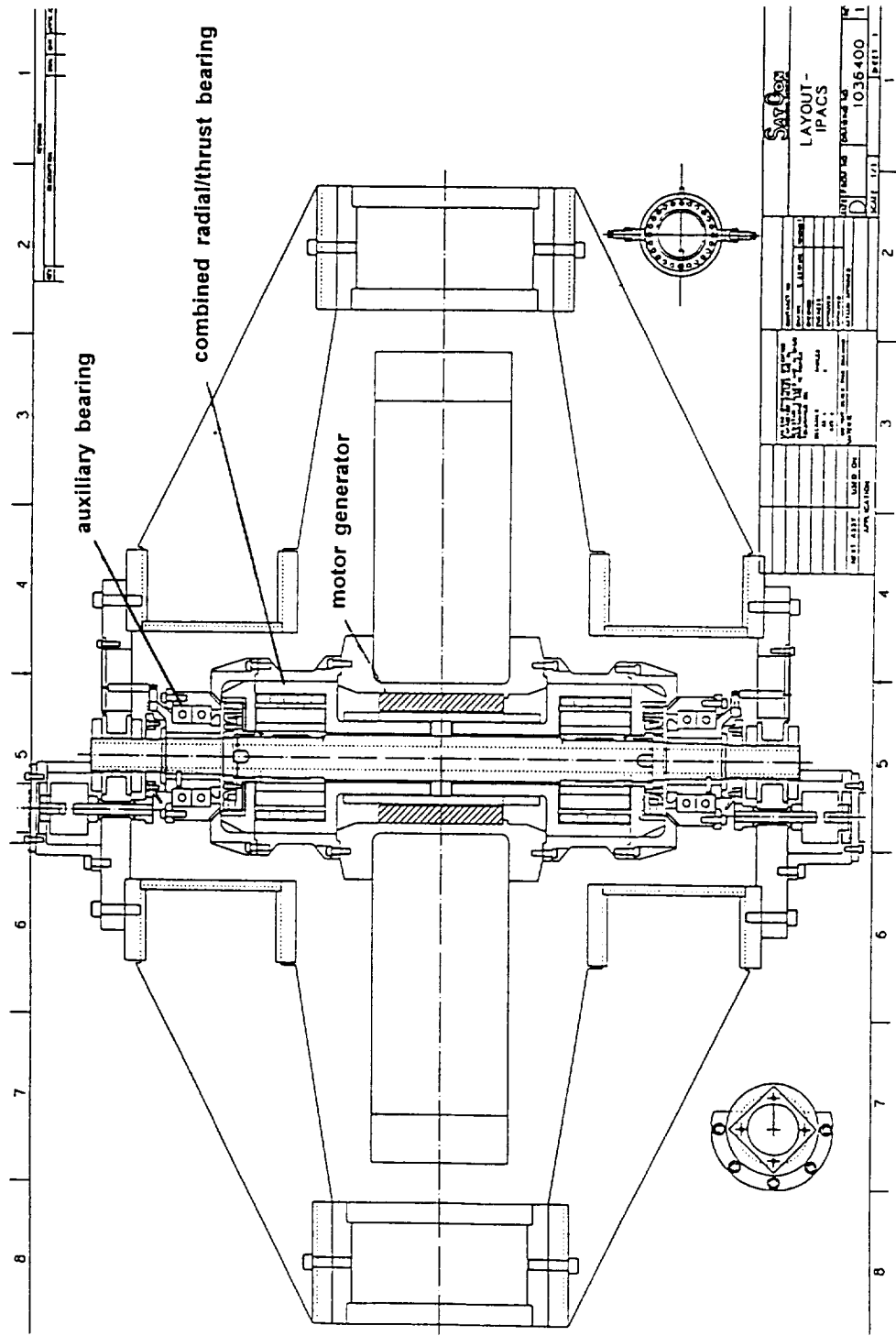

- **Status:**
  - **Assembly complete**
  - **Ready for testing**
  - **Instrumentation in progress**