

P-284

NASA Conference Publication 10108

# Fly-by-Light/ Power-by-Wire Requirements and Technology Workshop

*Edited by*  
Robert L. Baker  
*Research Triangle Institute*  
*Research Triangle Park, North Carolina*

Felix L. Pitts  
*NASA Langley Research Center*  
*Hampton, Virginia*

Proceedings of a workshop sponsored by  
the National Aeronautics and  
Space Administration and held at  
Langley Research Center  
Hampton, Virginia  
March 17-19, 1992

SEPTEMBER 1992

Review for general release September 30, 1994

(NASA-CP-10108)  
FLY-BY-LIGHT/POWER-BY-WIRE  
REQUIREMENTS AND TECHNOLOGY  
WORKSHOP (NASA Langley Research  
Center) 284 p

N95-10245

Unclass

G3/05 0022691

**NASA**

National Aeronautics and  
Space Administration

**Langley Research Center**  
Hampton, Virginia 23665-5225



# Contents

List of Abbreviations and Acronyms . . . . .	v
<b>1 Overview of Workshop</b>	<b>1</b>
<b>2 Principal Findings and Recommendations</b>	<b>7</b>
2.1 Individual Panel . . . . .	7
2.2 Common Findings . . . . .	10
2.2.1 Aircraft Systems Requirements and Architecture Study . . . . .	10
2.2.2 Leverage from Non-NASA FBL or PBW Programs . . . . .	11
2.2.3 Relationship with the FAA . . . . .	11
2.2.4 Merging of FBL and PBW . . . . .	13
2.3 Critical Issues . . . . .	13
<b>3 Proceedings and Findings for Panel Sessions</b>	<b>14</b>
3.1 Optical Sensor Systems (OSS) Panel . . . . .	14
3.1.1 Leading Particulars . . . . .	14
3.1.2 Proceedings . . . . .	16
3.1.3 Summary of OSS Requirements . . . . .	18
3.2 Power-By-Wire Technology (PBW) Panel . . . . .	20
3.2.1 PBW Introductory Session . . . . .	20
3.2.2 Secondary Electric Power Management (SEPM) Panel . . . . .	23
3.2.3 Electric Actuators (EA) Panel . . . . .	42
3.2.4 Electrical Engine Starter/Generator (EESG) Panel . . . . .	52
3.3 Fault-Tolerant Architectures (FTA) Panel . . . . .	72
3.3.1 Introduction . . . . .	72
3.3.2 NASA Plan Adequacy and Program Recommendations . . . . .	73
3.3.3 Requirements . . . . .	75
3.3.4 Open Issues/Requirements: . . . . .	77
3.3.5 Requirements/Issues to be Resolved with Other Areas . . . . .	83

3.3.6	Conclusions and Discussion of Dissenting Views . . . . .	83
3.3.7	Summary of FTA Findings . . . . .	85
3.4	Electromagnetic Environment Assessment (EME) Panel . . . . .	87
3.4.1	Electromagnetic Environment (EME) Panel . . . . .	87
3.5	System Integration and Demonstration (SID) Panel . . . . .	93
3.5.1	Leading Particulars . . . . .	93
3.5.2	SID Proceedings . . . . .	93
3.5.3	SID Findings . . . . .	101
3.5.4	Summary of SID Findings . . . . .	106
 <b>Appendix A: List of Workshop Attendees</b>		<b>A-1</b>
 <b>Appendix B: NASA FBL/PBW Program Plan</b>		<b>B-1</b>
 <b>Appendix C: Introductory Presentations</b>		<b>C-1</b>
	<b>FBL/PBW Requirements and Technology Workshop Overview - Felix Pitts . . . . .</b>	<b>C-2</b>
	<b>PBW Systems Panel Sessions Technical Work Plan - Louis Feiner</b>	<b>C-25</b>
	<b>Highly Reliable PBW Aircraft Technology Program Overview - Gale Sundberg . . . . .</b>	<b>C-36</b>
	<b>Electromagnetic Environment - Felix Pitts . . . . .</b>	<b>C-61</b>
 <b>Appendix D: Workshop Correspondence</b>		<b>D-1</b>
	<b>Invitation Letter . . . . .</b>	<b>D-2</b>
	<b>General Letter to Chairpersons . . . . .</b>	<b>D-6</b>
	<b>Letter to OSS Panel Principles . . . . .</b>	<b>D-11</b>
	<b>Letter to PBW Panel Principles . . . . .</b>	<b>D-15</b>
 <b>Appendix E: Final Panel Summary Reports</b>		<b>E-1</b>
 <b>Appendix F: Attendee Position Statements and Recommendations</b>		<b>F-1</b>
	<b>Letter - John McGough, Allied-Signal Aerospace . . . . .</b>	<b>F-2</b>
	<b>Letter - Franklin Banks, Banks Engineering and Labs . . . . .</b>	<b>F-4</b>
	<b>Letter - Carlos Bedoya, McDonnell Douglas . . . . .</b>	<b>F-7</b>

## List of Figures

1.1	Requirements Categories for Panel Sessions . . . . .	5
2.1	Aircraft Systems Requirements and Architecture Synthesis Study Approach . . . . .	12
3.1	Agenda . . . . .	24
3.2	PBW Generic Parts . . . . .	27
3.3	Generic Parts in a PBW Architecture . . . . .	28
3.4	SEPM Program Roadmap . . . . .	36
3.5	PBW Generic Parts - EESG . . . . .	53
3.6	Generator Control Unit . . . . .	55
3.7	Bidirectional Converter . . . . .	56
3.8	APU S/G - Internally-Mounted . . . . .	57
3.9	APU S/G - Externally-Mounted-Shaft Direct . . . . .	58
3.10	S/G, Main, Internal . . . . .	59
3.11	S/G, Main, External . . . . .	60
3.12	EESG Suggested Roadmap for Flightworthy Hardware Development . . . . .	68
3.13	Amended Plan for FTA WBS of NASA Program . . . . .	75
3.14	Development/Test Timeline . . . . .	107

## List of Tables

1.1	Agenda . . . . .	2
2.1	Key OSS Recommendations and Findings . . . . .	7
2.2	Key EA Recommendations and Findings . . . . .	7
2.3	Key SEPM Recommendations and Findings . . . . .	8
2.4	Key EESG Recommendations and Findings . . . . .	8
2.5	Key FTA Recommendations and Findings . . . . .	9
2.6	Key EME Recommendations and Findings . . . . .	9
2.7	Key SID Recommendations and Findings . . . . .	9
3.1	Issues discussed by the SEPM Panel . . . . .	29
3.2	Range of Currents (Amperes) Per Phase for Various Voltage Systems	31
3.3	Technology Readiness Assessment . . . . .	67
3.4	Major Systems Components . . . . .	98
3.5	Kinds of Testing Equipment for Ground Based Testing (Fly-By-Light)	99
3.6	Kinds of Testing Equipment for Ground Based Testing (Power-By-Wire)	99
3.7	Aircraft Integration and Testing . . . . .	100
3.8	Types of Ground Testing . . . . .	100
3.9	Types of Aircraft Testing . . . . .	101
3.10	Ground Integration Testing Facilities . . . . .	102
3.11	Attributes of Integration and Evaluation Architectures . . . . .	103
3.12	Aircraft Testing and Evaluation . . . . .	104
3.13	Ground Testing and Evaluation . . . . .	105

## List of Abbreviations and Acronyms

APU	Auxiliary Power Units
ARINC	Aeronautical Radio, Inc.
BDC	Bidirectional Converter
DoD	Department of Defense
EA	Electrical Actuators
EAPU	Electrical Auxiliary Power Units
EESG	Electrical Engine Starters and Generators
EHA	Electro-Hydraulic Actuators
EMD	Electric Motor Drive
EME	Electromagnetic Environment
EMI	Electromagnetic Interface
EMPC	Electromagnetic Power Controllers
FAA	Federal Aviation Administration
FBL	Fly-By-Light
FBW	Fly-By-Wire
FOCSI	Fiber Optic Control System Integration
FTA	Fault Tolerant Architecture
GCU	Generator Control Unit
HIRF	High Intensity Related Field
KVA	Kilovolt.amperes
LLNL	Lawrence Livermore National Laboratory
LLSF	Low-Level Swept Fields
MEA	More Electric Aircraft
MTBF	More Time Between Failure
Mtd	Mounted
NASA LaRC	Langley Research Center
NASA LeRC	Lewis Research Center
NSWC	Naval Surface Warfare Center
OEM	Original Equipment Manufacturer
OIDA	Optoelectronic Industry Development Association
OSS	Optical Sensor Systems
PBW	Power-By-Wire
PMAD	Power Management and Distribution
RCCBs	Remote Controlled Circuit Breakers
RMA	Reliability, Maintainability, and Availability
RMS	Reliability, Maintainability, and Supportability
RTI	Research Triangle Institute
SEPM	Secondary Electric Power Management

SID	System Integration and Demonstration
SSPCs	Solid State Power Controllers
SSRs	Solid State Relays
TAD	Technology Availability Date
TBD	To Be Determined
Vdc	Volts, direct current
Vac	Volts, alternating current
VHF	Very High Frequency
VMS	Vehicle Management System
VOA	Voice of America
VOR	VHF Omnidirectional Range
WBS	Work Breakdown Structure



## 1. Overview of Workshop

On March 17-19, 1992, the NASA Langley Research Center (LaRC), Hampton, VA, conducted a workshop on Fly-By-Light/Power-By-Wire (FBL/PBW) Requirements and Technology at the H.J.E. Reid Conference Center, Hampton, VA. Objectives of this workshop were to determine FBL/PBW program subelement technical requirements and needs from an industry viewpoint, to provide a forum for presenting and documenting alternative technical approaches, and to assess the adequacy of the NASA program plan in accomplishing plan objectives, aims, and technology transfer. The workshop was attended by 157 selected representatives from NASA LaRC, NASA Lewis Research Center (LeRC), the Federal Aviation Administration (FAA), the Department of Defense (DoD), academia, the airline industry, and the aerospace industry, including airframe manufacturers and specialized industry technologists. Appendix A contains a list of workshop attendees.

The NASA FBL/PBW program was developed by NASA Headquarters, NASA LaRC, and NASA LeRC in support of the NASA Aeronautics strategic thrust in *Subsonic Aircraft/National Airspace*. Specifically, this program is an initiative under Thrust 1, Key Objective 2, to “develop, in cooperation with U.S. industry, selected high-payoff technologies that can enable significant improvements in aircraft efficiency and cost.” Appendix B contains the NASA plan for the FBL/PBW program. The workshop was the first of a series aimed at maintaining and nurturing industry involvement for the purpose of facilitating technology transfer.

As shown in Table 1.1, the workshop consisted of an introductory meeting, a “keynote” presentation, a program question and answer session, a series of individual panel sessions covering specific technology areas, midcourse panel reports to all participants, final summarizing/integrating sessions for individual panels, and a closing plenary session summarizing the results of each panel’s activities. Felix L. Pitts, LaRC FBL/PBW Technical Program Manager, opened the workshop by introducing J. F. Creedon, Director for Flight Systems, NASA LaRC. Following a short welcoming address by Creedon, Felix Pitts presented an overview of the FBL/PBW program and discussed the objectives and structure of the workshop. He stressed that a significant challenge for this workshop was dictated by the fact that requirements for all technology areas are interdependent due to the systems context in which they all must function. To accommodate and account for synergistic sensor/architecture/actuator/power requirements, driving factors from each technology perspective had to be identified and communicated. Conflicting requirements across technologies needed to be resolved and a compatible set of requirements derived. This had to be accomplished while satisfying cost, manufacturability, flight worthiness, and certifiability goals. To help accomplish this vital coordination of inter-related require-

ments, discussion and interaction between session chairpersons were encouraged. It was further indicated that due to time considerations, indepth coverage of all requirements categories was not possible. It was, however, important that critical requirements/issues which would have substantial impact on technology areas be identified. Appendix C contains the viewgraphs used by Felix Pitts for his presentation.

Table 1.1. Agenda

**FLY-BY-LIGHT/POWER-BY-WIRE WORKSHOP  
NASA LANGLEY RESEARCH CENTER, HAMPTON, VA  
MARCH 17-19, 1992  
H.J.E. REID CONFERENCE CENTER**

**March 17, 1992**

8:30 AM	Register at Conference Center	
9:30 AM	Welcome	J. F. Creedon, LaRC Dir. for Flight Systems
9:45 AM	Program and Workshop Overview	Felix L. Pitts, LaRC FBL/PBW Technical Mgr.
10:30 AM	Break	
11:00 AM	Keynote Address	James Treacy, FAA National Resource Specialist
12:30 PM	Lunch (NASA Cafeteria)	
1:30 PM	Individual Panel Sessions	
3:00 PM	Refreshments Available	
4:45 PM	Adjourn	
5:00 PM	Cash Bar/Social at Conference Center	

Table 1.1 Agenda (continued)

**March 18, 1992**

- 8:30 AM Individual Panel Sessions
- 10:30AM Refreshments Available
- 12:30 PM Lunch (NASA Cafeteria)
- 1:30 PM Plenary Session: Midcourse Panel Summary Reports
  - 1:30 PM OSS Midcourse Summary Report
  - 2:00 PM SEPM Midcourse Summary Report
  - 2:20 PM EA Midcourse Summary Report
  - 2:40 PM EESG Midcourse Summary Report
  - 3:00 PM FTA Midcourse Summary Report
  - 3:30 PM BREAK
  - 4:00 PM EME Midcourse Summary Report
  - 4:30 PM SID Midcourse Summary Report
  - 5:00 PM OPEN FORUM
- 5:30 PM Caucus of Session Chairpersons and NASA Deputies
- 5:30 PM Adjourn
- 5:30 PM Cash Bar/Social at the Conference Center
- 7:00 PM Dinner at Fisherman's Wharf

**March 19, 1992**

- 8:30 AM Individual Panel Sessions
- 10:30 AM Refreshments Available
- 12:30 PM Lunch (NASA Cafeteria)
- 1:30 PM Plenary Session: Final Reports by Panel Chairpersons
  - 1:30 PM OSS Report
  - 2:00 PM SEPM Report
  - 2:20 PM EA Report
  - 2:40 PM EESG Report
  - 3:00 PM FTA Report
  - 3:30 PM BREAK
  - 4:00 PM EME Report
  - 4:30 PM SID Report
- 5:00 PM Adjourn

Milton Holt, Division Chief for Information Systems at LaRC, introduced the keynote speaker, James Treacy. Treacy, a National Resource Specialist for the FAA, discussed the introduction of advanced avionics technologies from a certification perspective. It was indicated that some areas of concern to the FAA for advanced systems were the certification of software for flight-critical functions, increased testing needed to certify avionics for the aircraft electromagnetic environment (EME), and certifying

architectures that use very large scale integrated circuits. Treacy noted that while the Boeing 777 and the McDonnell-Douglas MD12 will employ fly-by-wire (FBW) technology, no current U.S. transport aircraft use FBL/PBW technology. Based on this, Treacy speculated that the FBL/PBW program will be challenged to demonstrate to the airlines that FBL/PBW technology benefits exceed the risks.

After the keynote address, Herbert W. Schlickemaier, Program Manager, NASA Headquarters, and Felix L. Pitts answered questions from workshop applicants regarding the FBL/PBW program.

The first of a series of panel working sessions was held during the afternoon of March 17. Seven panels covering five major disciplinary areas were assembled from the workshop participants. These areas were: 1) optical sensor systems (OSS) including sensor and electro-optic converters; 2) power-by-wire (PBW) systems with panels for secondary electric power management (SEPM), electrical actuators (EA), and electrical engine starters/generators (EESG); 3) designed for validation FBL/PBW fault-tolerant architectures (FTA) based on electronic fault-tolerant computer systems with optical signaling interconnects for vehicle management, flight control, and PBW management; 4) electromagnetic environment (EME) assessment; and 5) system integration and demonstration (SID). Each panel had an industry chairperson, a NASA deputy, and a technical coordinator from the Research Triangle Institute (RTI). While each panel chairperson was responsible for structuring the panel's activities, panels were requested to:

- address the technical requirements, needs, and critical issues for the associated technology area
- determine requirements for technology demonstrations
- assess the adequacy of the NASA program with respect to objectives, weaknesses, risks, demonstration, and technology transfer
- determine the critical system requirements, issues and tradeoffs associated with inter-relationships between all technology areas
- consolidate, prioritize, and report the findings of the session activities

It was further requested that each panel address the following questions:

- What are the overall FBL/PBW requirements?
- What are the functional/capability requirements for FBL/PBW demonstration?

- Are there special requirements or issues that should be identified for this technology area with respect to certification, testing, reliability-maintainability-availability, fault tolerance, environmental requirements, etc?
- What are the requirements/issues with respect to integration of this technology into FBL/PBW ? (Carefully consider inter-relations with other technology areas.)
- What are the requirements/issues with respect to certification of FBL/PBW systems?

Figure 1.1 illustrates the general requirements areas that were suggested as appropriate for panel consideration. In addition, specific panels were requested to address certain specific issues or questions that were considered appropriate for the panels' technology area.

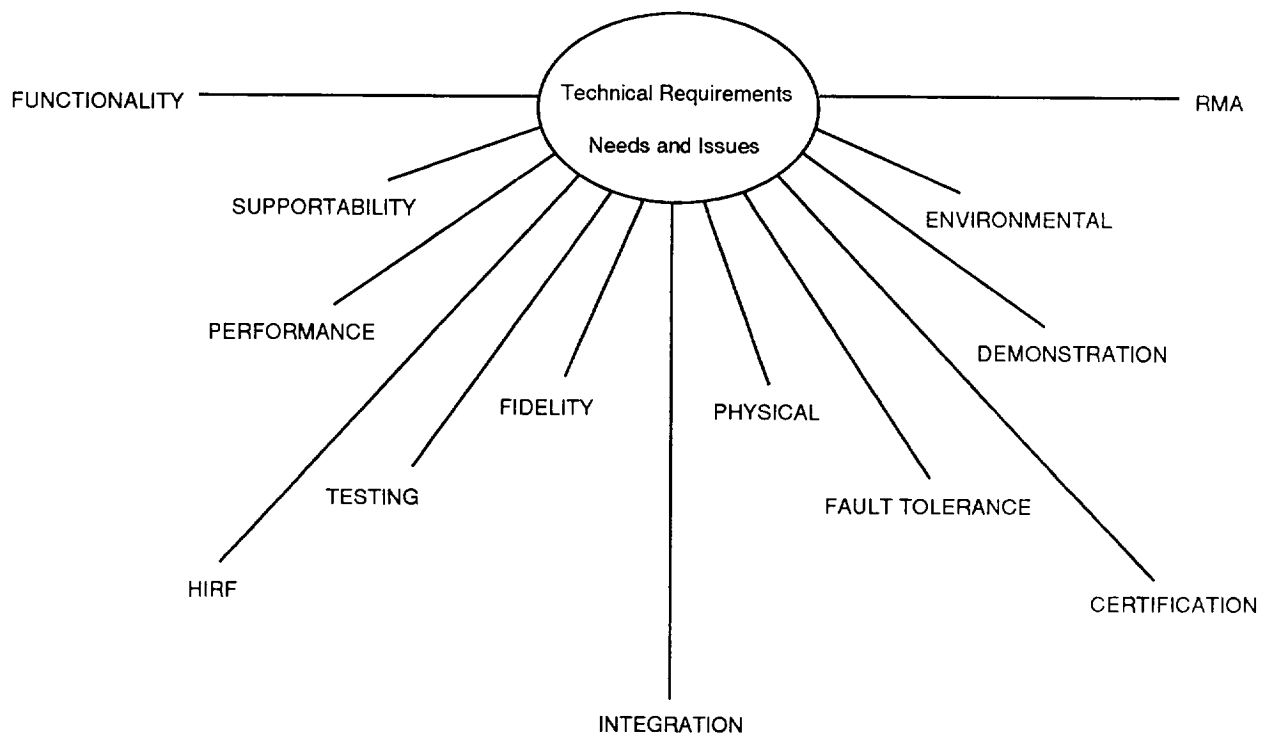

Figure 1.1. Requirements Categories for Panel Sessions

To foster and facilitate communication of the inter-related requirements and issues, each panel chairperson presented a midworkshop summary report to all participants

on the second afternoon of the workshop. Following these reports, the panel chairpersons and NASA deputies met to review workshop progress, discuss inter-related issues, and discuss panel activities for the final day of the workshop. In addition to the midterm reports, summaries of each panel session were distributed to all panels each morning of the workshop.

During the morning of March 19, panel sessions were held to complete panel discussions, to reach consensus, and to prepare a final summary report. Session chairpersons presented the final panel summary reports to all participants in the afternoon of March 19. Viewgraphs for these presentations are included in Appendix E.

Chapter 2 of this report summarizes the findings of each panel and Chapter 3 documents each panel's activities.

The text of this report is based on notes taken by session coordinators during panel sessions and on summary reports prepared by session coordinators in cooperation with panel chairpersons. These notes are supplemented by transcripts of midcourse and final summary presentations given by panel chairpersons during workshop plenary sessions. The RTI session coordinators were: 1) Jeff Bartlett (OSS), 2) Jorge Montoya (SEPM), 3) Ed Withers (EA), 4) Dave McLin (EESG), 5) Charlotte Scheper (FTA), 6) Aubry Cross (EME), and Robert Baker (SID). The panel chairpersons were: 1) Irv Reese (OSS), 2) Lisa McDonald (SEPM), 3) Ed Beauchamp and James Mildice (EA), 4) Rick Rudey and Thomas Jahns (EESG), 5) Dagfinn Gangsaas (FTA), 6) Richard Hess (EME), and 7) John Todd (SID).

Ingrid Agolia and Gail Loveland of RTI were responsible for preparation and revision of this report. Robert Baker of RTI and Felix Pitts of NASA LaRC served as technical editors.

## 2. Principal Findings and Recommendations

### 2.1. Individual Panel

Tables 2.1 through 2.7 summarize the principle findings and recommendations for individual panels. More detailed treatments of these items are contained in Chapter 3 and Appendix E of this report.

Table 2.1. Key OSS Recommendations and Findings

- Benefit Study of Merging FBL and PBW
  - Identify payoffs and how to accomplish payoffs
  - Merging has not been addressed previously
  - Integral part of scheduled FBL/PBW requirements study
- Analyze Test bed Options to Satisfy OSS Requirements
  - Closed loop engine and flight control
  - Significant flight hours
  - Feed-back and feed-forward optics
  - LaRC ATOPS 737 does not meet the above requirements
- FBL Establish Close Working Relationship with FAA

Table 2.2. Key EA Recommendations and Findings

- Integrate demonstration with other PBW programs (risk sharing)
- Change all-electric to more-electric
  - Cultural revolution required for all electric
  - Certification issues
- Demonstrate aileron, rudder, and spoiler in ground tests and aileron in-flight
- No EA showstoppers
- LaRC ATOPS 737 acceptable

Table 2.3. Key SEPM Recommendations and Findings

- Study to define system architecture and requirements
- Recommend 400 Hz near term
- 20KHz power will not be ready by 1996
  - Technological uncertainty
  - Impact on maintenance infrastructure
- Do more flight testing
  - Required for acceptance
- LaRC ATOPS 737 is an acceptable test bed
- Establish close relationship with FAA

Table 2.4. Key EESG Recommendations and Findings

- Recommend 400 Hz near term
- Recommend internally mounted EESG
  - Engine redesign
  - Eliminate gear box
  - Higher reliability necessary
  - Leverage DoD efforts



Table 2.5. Key FTA Recommendations and Findings

- Trade study and baseline benefits study for preferred architecture/target aircraft
- Develop industry standards
- Focus on certification methodology
- Establish close relationship with FAA
- Demonstrate flight-critical functions in flight
- Power is flight critical
- Human factors and pilot interface should be added to WBS

Table 2.6. Key EME Recommendations and Findings

- Three-dimensional, finite difference, time domain is preferred analytical methodology
  - First priority: Extend frequency range/spatial resolution
  - Second priority: Provide non-specialist interface
- Potential fly-by test sites for code validation
  - Voice of America
  - VHF Omni Range Sites
  - NASA-Wallops Radar
- LaRC ATOPS 737 ideal test vehicle

Table 2.7. Key SID Recommendations and Findings

- Requirements and architecture analysis and synthesis study
- Develop flexible research architecture
  - Insertion of new/alternate technology
  - Credible results
  - Incremental technology transfer
- Identify and evaluate ground and flight test beds for timely technology transfer
- Flight test optical closed loop engine control
- Flight test representative EESG (not panel consensus)
- Demonstrate flight-critical functions (not panel consensus)
  - Implies LaRC ATOPS 737 for flight tests does not meet requirements (LaRC ATOPS uses “Safety Pilot” concept)

## 2.2. Common Findings

### 2.2.1. Aircraft Systems Requirements and Architecture Study

Each panel with the exception of EME and EA recommended a study to determine system requirements and to establish the system architecture. The FTA panel recommended a trade study to determine a preferred architecture for a commercial transport and a baseline benefits study. The SID panel recommended a requirements and architecture analysis and synthesis study to determine requirements and architectures that support various phases of FBL/PBW integration, demonstration, and evaluation.

The FBL/PBW workshop established a large number of requirements and identified important design decision topics and issues. Most of these requirements were general enough to be better described as design constraints, objectives, and guidelines. Many open requirements and design issues were identified. Detailed design requirements and specifications could not be established because: the overall requirements were not available at this stage of the program, the system architecture must be established before certain requirements can be determined, and certain requirements are interrelated with several panel technical areas and must be determined through complex trade-off analyses. The program plan calls for a requirements study to be conducted during the early stages of the program. Panel recommendations confirm the necessity of this study.

The OSS panel recommended that a requirements study be conducted and that the study include a benefit assessment of the merging of FBL and PBW. A modest effort was suggested for the benefit assessment. The prevailing opinions expressed in the caucus of panel chairpersons and FBL/PBW program managers were that sufficient benefit studies had been conducted for FBL and PBW and that additional benefit studies were not necessary. The OSS panel noted, however, that while benefits for FBL and PBW had been separately assessed, none of the studies had assessed the benefits of merging the two technologies. SEPM recommended a study to define a power system architecture and requirements. While not specifically recommending a requirements study, EESG noted that the EESG design and requirements definition could not start until the power system architecture and requirements were established. The caucus of panel chairpersons recommended a requirements and validation architecture definition study.

Figure 2.1 illustrates the factors and perspectives that would influence a system requirements and architecture synthesis study. While high-level, general requirements can be established without knowledge of a specific aircraft system, knowledge of the aircraft system architecture is necessary to determine more detailed design requirements. Consequently, the study must also determine preferred candidate architec-

tures. In addition to technology factors, requirements definition and architecture selection must be driven by other factors such as cost, safety, maintenance, manufacturability, handling quality, and pilot interface. The study would have to address not only architectures and requirements suitable for commercial transport but would have to address the architectures and requirements for ground-based and flight-based system integration, evaluation, and demonstration. As noted in the SID proceeding and findings of Chapter 3, demonstration architectures will require the flexibility to support alternate FBL/PBW technologies.

### **2.2.2. Leverage from Non-NASA FBL or PBW Programs**

The NASA program plans call for use of the FBL technology base from the joint Navy/NASA program, FOCSI. There were frequent suggestions throughout the workshop that NASA should take advantage of the FBL and PBW technology bases or test beds that have been developed in other programs. The context of these suggestions were most often either budget constraints for demonstration or the development of timely technology readiness evidence. OSS recommended an analysis of test bed options other than those currently planned for the program. This was based on the need for significant flight test hours and closed loop engine control to demonstrate OSS technology. SID recommended that a survey be conducted to identify and evaluate existing alternate ground and flight test beds which would facilitate and enable technology transfer in a timely manner. However, participants in the PBW panels made the strongest recommendations for cooperation with other government PBW programs. EESG recommended that DoD efforts be leveraged. EA recommended risk sharing with other non-NASA PBW technology programs. Accordingly, there is a need to examine non-NASA FBL or PBW technology programs to determine if there are opportunities to leverage these to support the NASA development and demonstration objectives.

### **2.2.3. Relationship with the FAA**

The NASA plan calls for a close working relationship with the FAA. All panels recognized and emphasized the importance of FAA certification. OSS, SEPM, and FTA specifically recommended the development of a close working relationship with the FAA. It can be concluded that the planned FAA role in FBL/PBW should be maintained, and the efforts to foster and facilitate this vital interaction should be continued. Furthermore, the relationship should be monitored to assure that interaction is sufficient to meet program needs.

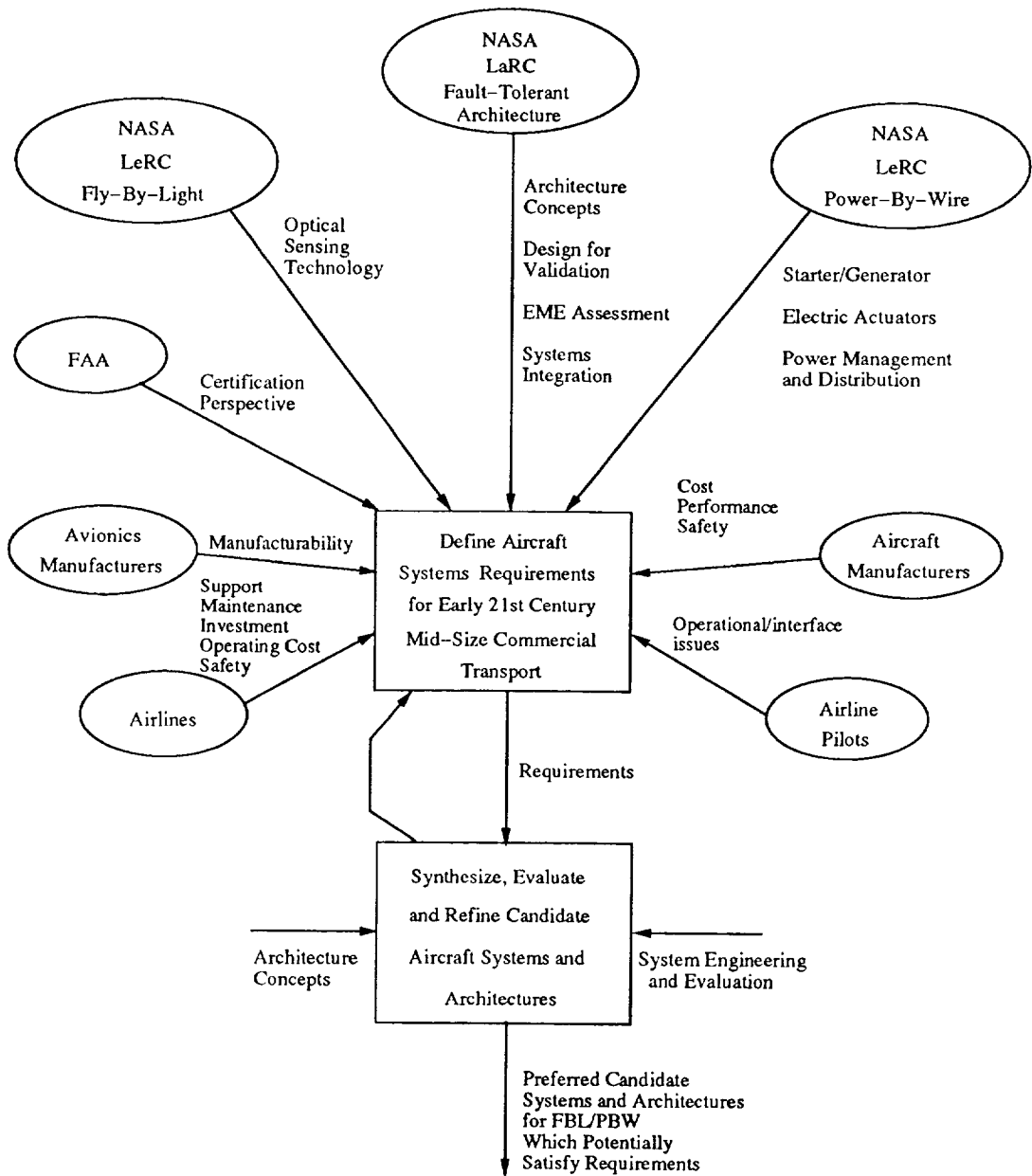

Figure 2.1. Aircraft Systems Requirements and Architecture Synthesis Study Approach

#### **2.2.4. Merging of FBL and PBW**

The merging of FBL and PBW technologies in the NASA program was discussed in SID, OSS, FTA, and EME; the chairpersons caucus; and in the keynote address. Participants inquired about the rationale for and the value of linking the two technology areas. OSS recommended a study to identify the payoffs of merging the technologies.

### **2.3. Critical Issues**

The critical issues identified in the workshop were the potential needs for flight test of the EESG component, of FBL in a propulsion system and of a flight-critical function. All of these would impact the adequacy of the LaRC ATOPS 737 for flight test and would have substantial cost impact on the program.

### 3. Proceedings and Findings for Panel Sessions

#### 3.1. Optical Sensor Systems (OSS) Panel

##### 3.1.1. Leading Particulars

The OSS panel was chaired by Irv Reese from Boeing Commercial. Robert J. Baumbick from NASA LeRC was the NASA deputy and Jeff Bartlett from RTI was panel coordinator. In addition, Randall Morton of ELDEC Corp., Andrew Glista of NAVAIR, Ed Mitchell of Douglas Aircraft and Kiyong Chung of General Electric were designated as panelists to aid the chairperson in preparing workshop visuals and in summarizing session content. The panel was comprised of 31 members whose names and affiliations are as follows:

<b>NAME</b>	<b>ORGANIZATION</b>
Irv Reese	Boeing Commercial (Chairperson)
Bob Baumbick	NASA LeRC (Deputy)
Jeff Bartlett	Research Triangle Institute (Coordinator)
Ralph Bielinski	Eaton Corp.
Victor Bird	Allison Gas Turbine
Paul Bjork	Honeywell
Joe Bluish	Allied Signal
Al Burckle	Naval Surface Warfare Center - Crane, In.
Kiyong Chung	GE Aircraft Engines
Stephen Emo	Allied Signal (Bendix)
Luis Figueroa	Boeing
Drew Glista	NAVAIR SYSCOM
Gordon Hamilton	Douglas Aircraft
Dave Holmes	NASA LaRC
Wayne Lance	Honeywell
Christopher Mayer	AMETEK Aerospace
Quin G. Mendosa	Boeing
Mike Miller	Litton
Ron Miller	GE Aircraft Controls
Ed Mitchell	Douglas Aircraft
Randy Morton	ELDEC Corp.

<b>NAME</b>	<b>ORGANIZATION</b>
Leon Newman	United Tech. Research Center
Jim Patterson	NASA LaRC
Gary Poppel	General Electric
Chuck Porter	Boeing
Stan Pruett	Wright Lab (Air Force)
Mike Rietz	McDonnell Aircraft
Scott Schaefer	Moog, Inc.
Dan Seal	McDonnell Aircraft
Gary Seng	NASA LeRC

In a letter to the chairperson and panelists of FBL/PBW Optical Sensor System (OSS) session, Robert Baumbick established the objectives for the OSS. The letter is contained in Appendix D of this report. The key questions to be answered by the OSS panel were:

1. What are the requirements for the OSS portion of this program?
2. If the program, as currently structured, is completed, will the results prove optical sensor system readiness from the technical point of view?
3. Will the results support simpler certification processes?
4. How do we best transition the technology into production systems?
5. What are the priorities for this technology to be transitioned?
6. What key issues (if any) must be worked with the other areas (sessions), especially fault-tolerant architecture definition, and power-by-wire?

The following issues were to be considered to answer the above questions:

1. Is the chosen test bed (LaRC ATOPS 737) a reasonable test bed for evaluation of optical sensor system networks? If not, what test bed is recommended?
2. Is the Optical Sensor System program designed properly to prove technology readiness?
3. Should the level of technology in this program consider:

- (a) fully redundant sensor architecture
  - (b) power by optics (using electrical BOM sensors for position)
  - (c) optical control of power to actuators
  - (d) smart sensor/actuator systems (local loop closure)
  - (e) built-in test capability and failure accommodation of sensor systems
4. What are the pros and cons of competing technologies vs. optical sensor systems?
  5. Should the program focus on technology readiness for the 1996 timeframe or beyond (year 2005)?

### 3.1.2. Proceedings

Following a brief discussion of an OSS workplan by Robert Baumbick, Gary Seng of NASA LeRC presented an overview of FBL development and test portion of the FBL/PBW program. Luis Figueroa of Boeing discussed the Optoelectronic Industry Development Association (OIDA), a consortium to improve worldwide competitiveness of the North American optoelectronic industry. Gary L. Poppel of General Electric and Dan Seal of McDonnell Aircraft gave separate briefings on the Fiber Optic Control System Integration (FOCSI) program activities in propulsion and flight control, respectively. Andrew Glista from NAVAIR SYSCOM discussed data network architectures for delivering distributed sensor data to processing resources in an integrated flight control system.

Panel discussions were first directed toward determining the requirements for the optical sensor systems of the FBL/PBW program. To obtain industry acceptance, the panel felt it was absolutely essential that OSS technology be demonstrated in flight for closed loop flight and propulsion control systems. The demonstration should include:

- Actuator position sensing using optical technology
- Optical control of actuators
- Thrust control for one engine using all optical technology
- Engine monitoring with optical technology
- Control for at least one aircraft axis using optical technologies
- At least two distinct OSS technologies, e.g., WDM, Lidar, Analog, etc.



The panel further recommended that an OSS configuration representative of a large aircraft be demonstrated and that the program build on the lessons of FOCSI and OPMIS. Failure monitoring, redundancy, navigation and guidance sensors, and hydraulic actuation must also be addressed for OSS. Finally, the panel recommended that the demonstration include significant flight time. It was strongly recommended that NASA conduct an analysis of test bed options that would satisfy the requirements established for demonstration. The suitability of the LaRC ATOPS 737 was questioned with respect to significant flight time, the need to demonstrate OSS on digitally controlled engines (LaRC ATOPS 737 doesn't have digitally controlled engines), and maintaining safe operation of the aircraft. It was noted that the Lockheed High Technology Test Bed, a C-130, has advanced systems installed on it and could potentially be available for supporting FBL/PBW demonstrations. The panel felt that a 757 or a DC-11 would be desirable for a test bed. The panel also noted that test bed options should not necessarily be restricted to a single aircraft. For example, flight control and propulsion control demonstrations could be conducted on different aircraft.

Establishing the credibility of OSS with original equipment manufacturers and end users was discussed by the panel. To establish that credibility, potential benefits such as manufacturing cost reduction, signal routing flexibility, reduction of connection paths, reduced direct operating cost, lower aircraft weight, and added functional capability must be demonstrated. In addition, use of the technology must not compromise safety nor introduce disadvantages that offset demonstrated benefits.

FAA interaction with the FBL/PBW program was considered necessary for program success. The panel recommended that:

- the FAA be familiarized with OSS technology
- the FAA be kept abreast of developments
- the FAA be informed on issues and solutions
- the FAA provide certification inputs and perspectives

While a number of studies have been conducted to identify the benefits of FBL or PBW technology, the panel noted that none of these studies addressed the benefits of combining the two technologies. The panel recommended that such a benefit study be included in the requirements study planned for the FBL/PBW program.

OSS integration on the aircraft and standardization of components and interfaces were identified as items to be established in cooperation with fault-tolerant architecture and systems integration areas.

Chairperson, Irv Reese, presented the OSS final summary report at the workshop closing plenary session. Viewgraphs used for this presentation are contained in Appendix E.

### **3.1.3. Summary of OSS Requirements**

#### General Requirements Recommended by OSS

- Demonstrate closed-loop control system in flight
- Make OSS Technology available 1996
- Establish credibility with OEM and end user
- Optical feedback of actuator position
- Optical control of actuators
- Optical control for hydraulic actuator
- Demonstrate optical control of one axis of aircraft
- Demonstrate control of thrust for one engine using optical technology
- Include optical NAV and guidance sensors in flight demonstrations
- OSS redundancy and fault monitoring must be included
- Include two distinct OSS technologies
- Demonstrate installation of OSS for large aircraft
- Utilize lessons from FOCSI and OPMIS
- Test bed available for significant hours

#### Open Issues Identified by OSS

- Test aircraft requirements?
- Do flight and propulsion tests need to be done on same aircraft?
- OSS integration and standardization issues?

- EME requirements for OSS?
- OSS technology availability status?

#### Recommendations by OSS

- Benefit study as integral part of requirements study at front of program to establish technology benefits and risks that must be tested to prove readiness

#### Requirements that Need to be Addressed by OSS

- Full complement of aircraft sensors and their fidelity, reliability, bandwidth, RMA, built-in test, etc.
- Network architecture for sensor data collection
- Sensor redundancy requirements
- Characterize failure modes and rates for OSS
- Maintenance/installation requirements

## 3.2. Power-By-Wire Technology (PBW) Panel

### 3.2.1. PBW Introductory Session

Due to the broad scope of PBW technology, the PBW portion of the workshop was addressed by three panels: Secondary Electrical Power Management (SEPM), Electrical Actuators (EA), and Electrical Engine Starters and Generators (EESG). Following the opening plenary session, the three panels met together. The agenda for this initial meeting was set forth in a letter to panel chairpersons from David D. Renz of NASA LeRC. A copy of the letter is contained in Appendix D.

Questions to be answered at the end of the PBW sessions were:

1. What are the requirements for the PBW portion of this program?
2. If the program, as currently structured, is completed, will the results prove power-by-wire system readiness from the technical point of view?
3. Will the results support simpler certification processes?
4. How do we best transition the technology into production systems? If not, what efforts need to be added to demonstrate technology readiness?
5. What are the priorities for this technology to be transitioned?
6. What key issues (if any) must be worked with the other areas (sessions), especially fault-tolerant architecture definition, and fly-by-light?
7. What results are expected from the the workshop?
  - measure system application state of readiness
  - measure component state of readiness
  - identify specific system development needed
  - identify specific component development needed
  - identify system integration development needed
  - scope out industry roadmap for all-electric aircraft

Issues for discussions expected to lead to answers to the above questions were:

1. Is the chosen test bed (LaRC ATOPS 737) a reasonable test bed for evaluation of a power-by-wire system? If not, what type test bed is recommended, how many, what locations, etc.? What has to be flown to prove flight readiness?

2. Is the PBW program designed properly to prove technology readiness? If not, what changes should be made? What should the technology roadmap be?
3. Should the level of technology in this program consider:
  - fully redundant power system (fault-tolerant)
  - built-in test capability
  - smart electrical actuators
4. What are the pros and cons of competing technologies (e.g., high pressure hydraulics) vs. power-by-wire systems?
5. Should the program focus on technology readiness for the 1996 time frame or beyond (year 2005)?
6. Distributed power and load control vs. centralized architecture
7. PMAD Architecture - fault-tolerant avionics architectures

Gale R. Sundberg of NASA LeRC presented an overview of the PBW technology program. He reviewed the results of PBW technology benefits studies, which indicate that PBW saves weight, fuel, and life-cycle costs. Critical technologies were identified, and the structure and schedule of the NASA PBW plan were reviewed. The viewgraphs for Gale Sundberg's presentation are contained in Appendix C.

Dick Quigley of Wright Laboratories discussed the More Electric Aircraft (MEA) program. Eike Richter of General Electric Aircraft Engines gave a presentation on an Air Force-sponsored program to develop a 375kw integral starter/generator. Louis J. Feiner of McDonnell Douglas gave a presentation on a NASA sponsored all-electric conventional technology study for civil transport aircraft.

Next, Louis Feiner, in his role as PBW Chairperson, discussed how the individual PBW panels should conduct their work, discussed the general questions and issues that should be addressed, provided worksheets and parts lists to aid panel efforts, and provided a time table for panel activities. Viewgraphs for this presentation are contained in Appendix C. Ed Beauchamp of Allied Signal and Dick VanNocker of General Electric responded to an invitation to panel members for a short presentation on PBW technology perspectives. Ed Beauchamp posed the question, "Why more electric, and why not all-electric?" It was indicated that high temperature environments and high peak power requirements do not favor electric power. Dick VanNocker discussed the value of higher voltage levels for PBW components and needs for alternating and direct current power.

A summary of issues and observations regarding the presentations and ensuing discussions are:

- Convincing industry to adopt all-electric aircraft will be a significant challenge. Industry needs to see significant advantages related to all-electric. Mentioned were: reduced capital acquisition costs, significant fuel savings (> 10%), or significant weight savings (> 30,000 lbs.)
- Certification is considered to be a challenge both by industry and the FAA
- Studies indicate payoff by replacing current power systems with electric systems
- The following must be defined to put FBL/PBW into practice:
  - Critical requirements
  - Key interface issues
  - Technology insertion issues and timing
  - Technology roadmap
  - Roles of NASA, Industry, FAA, and Airlines
  - Test beds: Ground based and/or flight based
- Need to look at test techniques to see what will provide the necessary level of confidence and meet certification
- Need to consider system integration and airframe limits from the start
- Need to look at current certification requirements to see if they make sense in light of an all-electric aircraft

Issues identified as important for discussion with other panels were:

- How will design of power distribution affect reliability of overall system?
- What communications mechanisms are required to allow PBW to work?
- What common frame of reference can all PBW panels use to discuss topics of common interest?

For the remainder of the workshop the PBW panels conducted separate sessions. Activities for each PBW panel are summarized in the following sections of this report.

### 3.2.2. Secondary Electric Power Management (SEPM) Panel

#### 3.2.2.1. Leading Particulars

The Secondary Electrical Power Management (SEPM) panel, a subgroup of the Power-By-Wire (PBW) Systems and Components Working Group, met on March 17, 1992 to discuss issues and identify requirements associated with SEPM system design and implementation. After receiving its points of reference from the PBW group chairperson, Louis Feiner of McDonnell-Douglas, the SEPM panel met late in the afternoon of Tuesday, March 17, 1992 to begin its work. Panel chairperson, Lisa McDonald of McDonnell-Douglas, welcomed the participants and introduced the government representative, Barbara Kenny of NASA/Lewis Research Center, and the RTI representative, Jorge Montoya.

Seventeen people attended the panel session. Of those, seven represented the government, two represented airframers, seven represented equipment manufacturers, and one was a university researcher. A list of attendees follows:

<b>NAME</b>	<b>ORGANIZATION</b>
Lisa McDonald	McDonnell-Douglas (Chairperson)
Barbara Kenny	NASA/Lewis Research Center (Deputy)
Jorge Montoya	Research Triangle Institute (Coordinator)
Anthony Coleman	Sverdrup Technology, Inc.
Chuck Meissner	NASA/Langley Research Center
Keith Young	NAWC/ACD-Warminster
Kevin McGinley	NAWC/ACD-Warminster
Rick Fingers	USAF WL/POOX
Lou Feiner	McDonnell-Douglas
Steve Buska	Honeywell
Dick VanNocker	General Electric/Binghamton
John N. Rice	Sundstrand
Don Backstrom	Westinghouse
Bill Jackson	Martin Marietta/Denver
Ralph Bielinski	Eaton Corporation
Bill Campbell	Hughes, MCD
Oleg Wasynczuk	Purdue University

The overall objective of the workshop was to determine the technical requirements and assess the adequacy of the program plan for the FBI/PBW program. As such,

the general objective of the SEPM panel was to generate inputs to support these two general objectives in the SEPM area. Among the initial questions which helped frame the subsequent discussions were: What constitutes a suitable definition of the Secondary Electrical Power Management system? What should its architecture look like and what should its relationship to the rest of the aircraft be? What technologies need to be developed in order to enable this part of the program? The following agenda, Figure 3.1, was proposed by the chairperson to guide the panel's discussions.

- Introduction
- Discussion (continued from PBW group)
- Review Workshop Objectives
- Concur on SEPM equipment
- Technical Requirements
  - Critical Requirements, needs
  - Interface Issues/Tradeoffs
- Technology Demonstration/Insertion
  - Issues
  - Timing
- Technology Roadmap
- Review NASA Program Plan
- Roles of NASA, FAA, Industry, Airlines
- Summarize

Figure 3.1. Agenda



### 3.2.2.2. Proceedings

Having agreed on an agenda, the panel established guidelines to further focus the discussions. The guidelines established were: 1) discuss viable technology; 2) establish a realistic technology availability date (TAD); 3) concentrate on realistic power types; 4) specify needed levels of redundancy; and 5) establish realistic reliability, maintainability, and supportability (RMS) goals.

The panel agreed that in its technology review it should emphasize technology verification in order to facilitate the certification of the FBI./PBW aircraft. Furthermore, in order to meet the program development schedule suggested by NASA, the panel settled on a TAD for early 1995. The 1995 TAD was chosen over a 2005 TAD to attempt to influence upcoming commercial aircraft programs and to take advantage of the synergism of the Air Force More Electric programs already in progress. This means that all the proposed components would be validated and ready for integration tests by this date.

Concerning power types, there was some uncertainty as to what the generator group would be giving the SEPM for power. The panel discussed a variety of voltage amplitudes and types that might be available in the aircraft by 1995. These voltages included the standard low dc voltage (28 volt dc); high dc voltage (270 volts dc); standard, constant frequency, ac voltage with the frequency being as high as 1,200 Hz; and variable frequency, ac voltage with the frequency ranging from 400 Hz to 1,200 Hz. A conventional distribution system voltage (115 Vac at 400 Hz and 28 Vdc) provides the lowest risk approach, allowing easy compliance with the first two guidelines. To address technical issues, however, the panel recommended NASA also consider a higher, but constant frequency ac system (1200 Hz max.) and a variable frequency ac system (400 Hz to 1200 Hz max.). In light of the work being performed on several military programs, high voltage dc (270 Vdc) power was also recommended. The panel also discussed high-frequency ac voltage and came to the conclusion that for the TAD identified, 20kHz equipment would not be readily available and the customer (airlines) would be reluctant to accept the 20 kHz technology. It was recommended that 20 kHz not be considered for this program. It was agreed that there should be a short-term and a long-term technology issues list and that the high frequency ac voltage should be included in the long-term list.

The panel next examined various levels of redundancy required by different aircraft loads. Three levels of redundancy were identified: flight-critical, essential, and utility. Flight-critical redundancy implies fail op, fail op, fail safe. Essential redundancy implies fail op, fail safe. Utility redundancy implies fail safe.

Concerning reliability, maintainability, and supportability (RMS), the panel specified that the expected RMS of the proposed equipment should be better than or

equal to that of existing equipment.

The panel identified the major functions and components associated with the SEPM area. Figure 3.2 identifies the SEPM portion of the overall generic secondary power system architecture. This diagram is based on current practice in aircraft electrical systems and on the panel's view of the implications of PBW technology. Functions of the SEPM included power distribution, control, and sensing; fault isolation; load management; circuit and system protection; and may also include power system control and information processing, control interfaces, and collection of electrical load information. Figure 3.3 lists the generic parts in a PBW architecture. Key components included batteries and battery chargers; localized conversion equipment; solid state and electromechanical contactors, relays and switches; remote power controllers and circuit protectors; wire and cable; sensors; load management centers; and control processors. It should be noted that the bus tie relay was moved from the EESG area to the SEPM area because the panel felt that this is a piece of equipment that can be managed effectively in the aircraft. In addition, there was some in-depth discussion as to whether the batteries and the battery chargers should be included in the SEPM list since they are sources of power. The panel decided to leave them under the SEPM heading.

The panel next generated a list of general issues to discuss. These issues were classified into three categories: general, equipment-related, and architectural. They are summarized in Table 3.1.

The first of the general issues was design for certification. The main point was that SEPM designers need to use the existing regulations as a solid baseline for the design. The second issue was power type. Designers must give special attention to the compatibility of the power type with existing sources and loads. Power requirements for engine starts must be established. Concern was also expressed over the possible effect of a high frequency distribution system on the avionics instrumentation. It was determined that the SEPM must interface with ground power, auxiliary power unit (APU), and battery power. The capacity of the APU or cart for engine start must be specified.

Another general issue of discussion was the SEPM system data interface. Questions which must be resolved are: What standard should the data bus follow? Should there be a fiber optic link? What technology should be used? Should the signal levels be all discrete? Other issues which must be addressed are environment, power quality, and electromagnetic emissions regulations. The selection between a dedicated electrical power control or an integrated system control must be made and the allocation of control software to appropriate computers must also be decided.

The packaging standards and requirements to which the designers must design,

# PBW Generic Parts

Shopping List

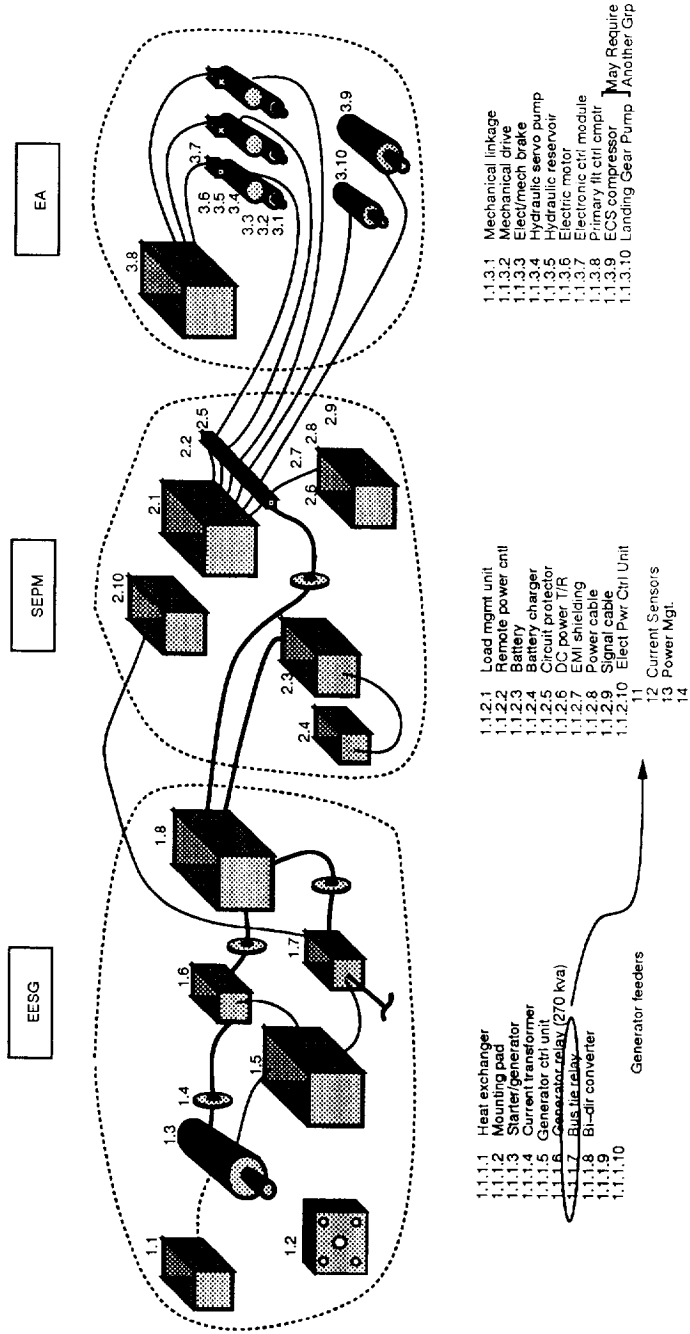

Figure 3.2. PBW Generic Parts

# Overall Generic Secondary Power System Architecture

NASA Power-by-Wire Systems (PBW) Workshop

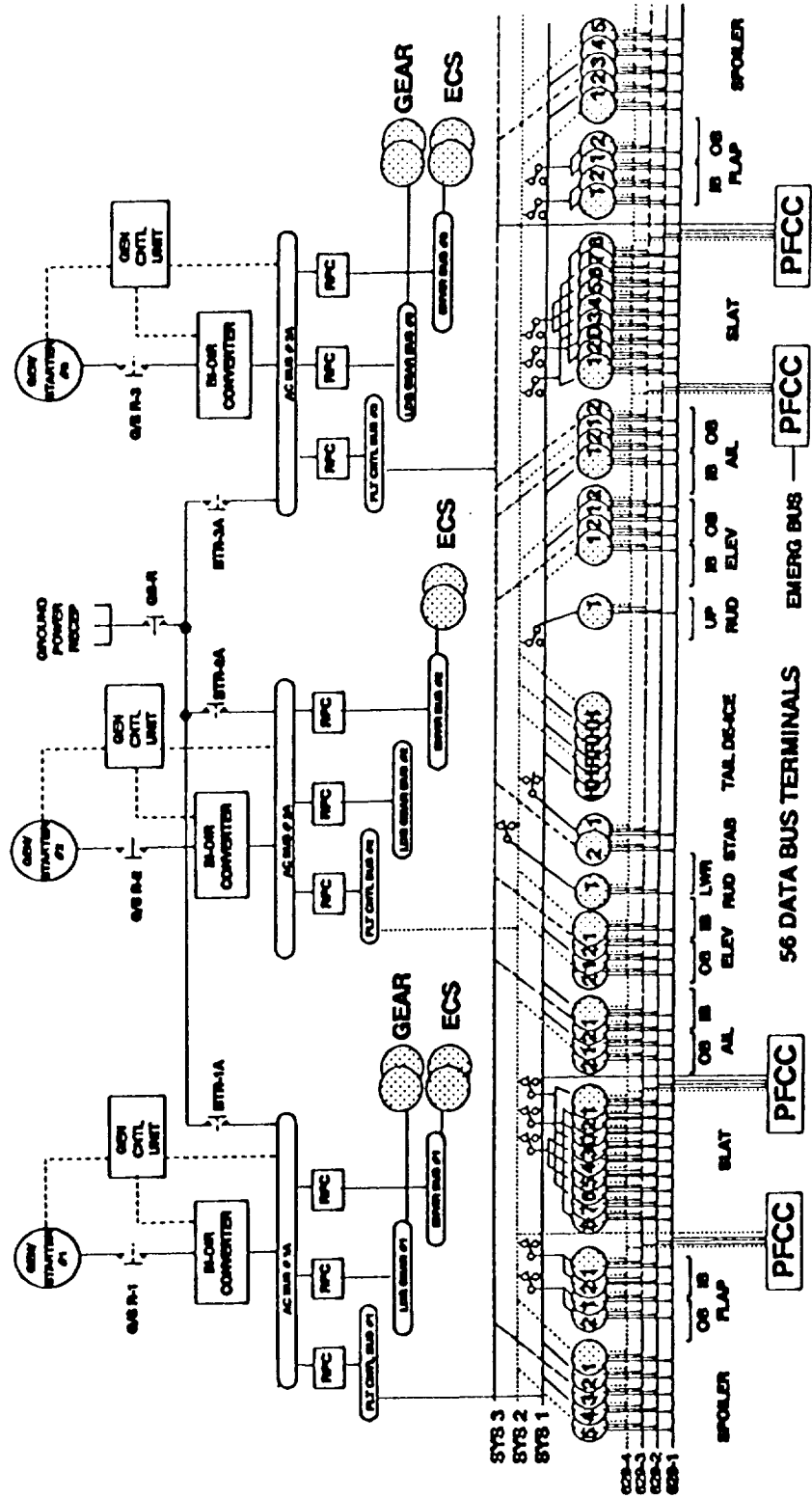

Figure 3.3. Generic Parts in a PBW Architecture

Table 3.1. Issues discussed by the SEPM Panel

GENERAL ISSUES	FUNCTIONS	EQUIPMENT, TECHNOLOGY AND ISSUES
<ol style="list-style-type: none"> <li>1) Design for certification (Baseline – check regulations)</li> <li>2) Power type (compatibility with existing source/loads)</li> <li>3) Ground Power/Auxiliary power/battery power</li> <li>4) Capacity of APU of cart to start engine</li> <li>5) Interface issues               <ul style="list-style-type: none"> <li>– data bus (which standard?)</li> </ul> </li> <li>6) Common environmental and power quality regulations</li> <li>7) Where do we draw the line for control responsibilities?</li> <li>8) What are the packaging standards/requirements</li> <li>9) Common electronic equipment specifications</li> <li>10) Airline (customer) acceptability               <ul style="list-style-type: none"> <li>– Minimize changes to their infrastructure (maintenance procedures, etc.)</li> </ul> </li> <li>11) What models, handbooks, etc., do we use for RMS?</li> </ol>	<p>Power Sense control – switching protection processing</p> <p>Information (data) processing (status, SEPM info, proc., data/interface w/other systems, crew inputs)</p> <p>System protection (coordination)</p> <p>Fault isolation (centralized vs. localized)</p> <p>Load management – sharing/shedding</p> <p>Circuit protection</p>	<p>Cabling</p> <ul style="list-style-type: none"> <li>* integrated power &amp; signal cable (data bus and optical)</li> <li>* organized wiring (ribbonized/round)</li> <li>* grounding schemes for hybrid systems</li> <li>* high voltage cabling</li> <li>* wire/cable diagnostics</li> </ul> <p>Connectors</p> <ul style="list-style-type: none"> <li>* high current</li> <li>* integrated cable connector</li> <li>* review/revise standards</li> </ul> <p>Switching Components (VOLTAGE/CURRENT considerations)</p> <ul style="list-style-type: none"> <li>Relays (EM)</li> <li>Relays (SS)</li> <li>Relays (Hybrids)</li> <li>Define "smart"</li> </ul> <ul style="list-style-type: none"> <li>* High               <ul style="list-style-type: none"> <li>28 vdc</li> <li>270 vdc const f</li> <li>var f</li> </ul> </li> <li>* Low:</li> </ul> <ul style="list-style-type: none"> <li>* Circuit Protection:</li> </ul>

common electronic equipment specifications, and the customer criteria for accepting this technology must be identified. The panel felt that the customer will want a minimum impact on its infrastructure, e.g., maintenance procedures. The models, handbooks, etc., which should be used for reliability, maintainability, and supportability must be established.

The SEPM functional issues discussed by the panel included power sensing, power control, power protection, and power processing. The panel also discussed information processing, system protection, fault isolation, load management, circuit protection, and load information. Although most of these issues are self-explanatory, some of them merit further discussion.

For example, information (data) processing involves processing of the status information collected from the various equipment in the distribution system. It includes information processing, data, and interfacing with other systems, and also crew inputs. System protection and fault isolation are two other important SEPM functional areas. If there is a fault or a failure, it is desirable to isolate it at the lowest possible level to minimize the impact on other equipment. Another functional area, load management, can be addressed with a multiple strategy, which includes sequencing, sharing, and shedding of electrical load as needed. This approach could allow the EESG designers to decrease the size of the generators. Circuit protection and load information must also be considered. The advent of intelligent devices makes it possible to know the current and voltage associated with a load. This information can be used as a basis for a diagnosis tool.

The panel identified the following wire and cable issues: Should integrated power / signal (data bus/optic) cable be used in the FBL/PBW aircraft? Should the organized wiring used in military aircraft such as ribbon cable or round conductor with woven type construction be used in civil aircraft? What grounding schemes are appropriate for a hybrid, non-conventional ac and dc system? It should be noted that high voltage/current cabling technology may be limited due to susceptibility to corona effects. Dielectric testing on these cables may be required. The panel also recommended the use of wiring cable diagnostics. A panel member noted that on military platforms the wiring accounts for thirty percent of all recorded failures, and that if the civilian experience has been similar, avionics reliability could be substantially improved by improving wiring technology.

The panel identified the following connector issues: What are the requirements for high-current connectors? What is the impact of using different cable types? The panel also strongly suggested a review and/or revision of connector and wiring standards. In the opinion of the panel, such a revision could have a significant impact on cable weight.

At a higher level in the distribution system, the panel addressed switching issues. Switching can be accomplished in one of three ways: electromechanical (EM), solid state (SS), and hybrid (H). A hybrid switching device has an EM relay in parallel with a solid state switch. The panel characterized the range of currents that could be switched by the different switches for the various voltages of interest.

The panel also established that current technology limits solid state switching devices to about 50 amperes for both ac and dc voltages. Similarly, the hybrid switches can handle 300 amps dc and 400 amps ac. A manufacturer attending the workshop mentioned to the panel chairperson that he knows of a device that can handle 1000 amperes. The panel noted that frequency was the primary limitation for ac systems and that the use of non-standard frequencies would require significant development. Table 3.2 summarizes current switching limitations.

Table 3.2. Range of Currents (Amperes) Per Phase for Various Voltage Systems

	EM	SS	H
28 Vdc	-	-	
270 Vdc	300	50	300 → 1000
Constant f	*	50	400
Variable f	*	50	400

\* Frequency limitation not a current limitation  
 (EM) Electromechanical  
 (SS) Solid State  
 (H) Hybrid

The issues with switching identified by the panel include: How smart do these devices need to be? Should the intelligence be localized in the switches or be located remotely? What kind of feedback should be used? And what kind of interfaces to what kind of devices should there be in the system? The panel also expressed some concerns about thermal environment and management for solid state switches.

This concluded the panel discussions of Wednesday, March 18, 1992. The panel reconvened on Thursday, March 19, addressing circuit and system protection devices and associated technical issues.

The role of these devices is to protect the circuit wiring and the integrity of the system. They range from the conventional types, like fuses to intelligent devices. Circuit breakers, solid state power controllers (SSPCs), fuses and current limiters,

hybrid power controllers (PCs), electromechanical power controllers, and diodes are included. The panel discussed some circuit protection technical issues associated with these devices.

The adequacy of solid state devices to protect wiring was discussed. Protection against arc propagation and high-impedance failures were the primary considerations. With the incorporation of PBW technology, protection requirements for conventional load characteristics and new load characteristics must be examined. The protection requirements that must be placed on solid state devices must be carefully considered. It was observed that there is evidence of failures by conventional circuit breaker and fuse devices that may be due to conditions outside of design specifications.

The needs for load accommodation and for coordination with the operation of the circuit protection devices were discussed. Ancillary issues in this area include the handling of pulsed switching loads, current inrush, etc. It was pointed out by a panel member that this is perhaps the first time that aircraft electrical system designers will be faced with the types and magnitudes of loads that will be present in the FBL/PBW technology aircraft. Consequently, the dual constraints of protecting the wires and accommodating the loads will be a design challenge.

The panel identified the need for bi-directional protective devices to accommodate regenerative components which can both source or sink power.

Cost emerged as a major issue in the panel discussions. There are a number of expensive protective devices which may be needed by this aircraft. A trade analysis to identify the most cost-effective combination of devices that meet requirements was recommended.

The panel also discussed several other issues including thermal, built-in test (BIT), cost reduction, standardization, autonomous operation, and cost/benefit issues.

The next area of panel discussion was load management devices and associated technical issues. Load management devices include remote controlled circuit breakers (RCCBs), solid state power controllers (SSPCs), solid state relays (SSRs), smart relays, and connectors. It should be noted that some of these devices can also be used for circuit protection. Designers may use a single device to perform the function of two devices, circuit protection and load switching. For example, in dynamic load management where the system is designed to interactively turn on and turn off electrical loads as a function of mission profile or emergency condition, the design calls on the same device to perform two functions. Some of these devices, such as RCCBs, are intelligent devices which provide a status return for remote monitoring and control.

The load management device issues discussed by the panel can also be considered to be systems issues and as such this discussion affects other groups. The panel



discussed architectures both from a main power distribution point of view and from a mode control management point of view. The panel concurred that the system design needs to be examined thoroughly. It was the opinion of the panel that the FBL/PBW aircraft will be so complex that it will be unwise not to consider the source and load requirements independently and up front. For the first time, the designer will not be able to address these problems at the last stage of the design. The panel concluded that the system design should be hierarchical and iterative.

Other issues addressed by the panel included redundancy, interfaces, software, control algorithms, throughput, levels of autonomy, interactions with vehicle management, system integration, prioritization of loads, relationship to flight control system, BIT, processing capability, reliability, and human factors.

The panel stressed the need for standardization work with respect to interface design because the SEPM will have more interfaces than most other systems in the aircraft. There was a great deal of discussion regarding whether subcontractors or airframers should develop and control power management software. The degree and levels of autonomy for the SEPM system and the interaction of SEPM with the vehicle management functions must be specified.

Another key issue discussed by the panel was related to the prioritization of loads. The policy for prioritizing loads must be determined so that the most essential loads are serviced in degraded modes.

The panel also discussed the need to examine the power specifications and requirements for flight control. In the case of hydraulic power, the hydraulic system must provide power to the hydraulic flight control components. Providing reliable electric power for twenty-five (25) actuators, ranging from 20-100 horsepower, is a significant design challenge.

Additional discussions took place concerning processing capability in the system. How much processing power should there be? The type and degree of redundancy was discussed. Here the panel wrestled with preventing single point failures. No specific recommendations could be made at this early stage.

The panel also discussed the issue of human factors design features. Specifically, how does the designer compensate for the maintenance man who is used to pushing circuit breakers to trouble shoot the electrical circuits.

The panel completed its discussions on technical issues by considering power conversion. The panel discussed whether the system design should be centralized or localized. In other words, should the design have power converting equipment that is large and in a central location? Or, should the design include localized power conversion so that generator power is received and locally converted at the load management center? The selection of a configuration needs to be addressed in the initial

trade studies.

The panel next discussed the conversion problems associated with the use of 270 volt dc power in the aircraft. If this voltage is to be incorporated in the system, the panel felt that some of the converting equipment may not be available, especially the large power rating conversion equipment. The use of variable frequency ac voltage was also discussed by the panel. Constant frequency ac power converting equipment is the current approach. If the design calls for a variable frequency that ranges from 400 Hz to 1,200 Hz, the impact on conversion equipment must be carefully considered.

Concerning systems issues, the SEPM panel suggested that the architecture (both control and power) needs to be addressed at various levels including the system level, the SEPM level, and the load level. Redundancy, reliability, and human factors requirements all will affect how the SEPM system is designed.

Having completed the systematic discussion of devices, functions, and technologies associated with the various functional levels of the SEPM system, the panel proceeded to define a program for development. The panel identified a list of SEPM related issues or items where additional work is needed, and prioritized the items to provide a guide to the government for funding. The panel identified five work breakdown structure items which are system architecture definition, component technology development needs, load management related research, tests and demonstrations, and modeling and simulation.

The highest priority was assigned to the system architecture definition and several trade studies that will be necessary to support the definition phase. This phase should address as a minimum the following areas: number/types of power sources; bus configuration; degree of automatic control in the system; characterization of the load requirements and power types; control strategy; interfaces with other systems; level of redundancy; built-in test; and load management.

Once the system is defined, the panel felt that the government needs to focus on component development work. Specific components to be developed cannot be determined until the system study is complete. However, the panel identified some important technology gaps that need to be addressed. These include: high current/high voltage devices (e.g., SSPCs) for the various voltage types; bi-directional switches (for handling regenerative power); power management centers; power conversion equipment or devices; advanced device cooling (where device means both solid state circuits as well as very large converting and switching equipment); high-temperature electronics; sensor technology development (dc current sensing may present a problem in some cases); circuit protection with respect to arc propagation and high-impedance failures (is it desirable to have the circuit devices and protectors recognize devices and isolate conditions?); cable, wire, and connector development (depending on what system is

chosen); and modular switching package.

The third priority item identified was load management related research. As a minimum, the following subjects need to be addressed in this area: packaging, architectures, interfaces, and environment (including electromagnetic emissions (EME) and thermal conditions). Load management control specifications must be developed. Control and data processing, redundancy, and system protection areas must be examined. If distributed power conversion is selected, the conversion equipment which will be embedded in the load and the load management and solid state switching devices must be specified.

The panel recommended some test and demonstration activities associated with the SEPM system development program and suggested that it be given fourth priority. The panel further subdivided this area into a ground and flight test segment. Some of the areas that should be addressed in the ground phase of the test and demonstration include: power quality, power stability, and EME testing (limited and as required because it can be very expensive); and normal and abnormal operation in fault injection or fault isolation (how does the system perform under various fault failure conditions)?

The last area recommended by the panel is modeling and simulation. This is given the lowest priority and should be done very judiciously because it is potentially expensive. The panel identified the following areas where modeling and simulation could be useful: reliability, functional performance both at the equipment level and at the system level; component behavior; circuit simulation; and worst case fault and failure analysis.

The flight test segment of the test and demonstration activities was discussed. As a preliminary to specific recommendations, the panel addressed the following questions: What is an acceptable test bed? From the perspective of the SEPM panel, the NASA LaRC ATOPS 737 is an acceptable test bed. Are there other types of test bed that the panel recommends? If the intent is to do system testing, the test bed should be a transport aircraft. If the intent is to do component testing, any military or commercial aircraft would do. What needs to be flown to demonstrate flight readiness? The panel concluded that if the technology is new, the program needs to fly at least one power channel. The generating system down to powering one of the electrical actuators was considered by the panel to be a complete power channel. Any new technology system component (at least a load management unit) needs to be flight tested.

The panel developed a program roadmap for SEPM based on the work breakdown structure just discussed. This roadmap is illustrated in Figure 3.4. Item A is the system architecture definition. A start date of June 1992 and a period of performance of one year is suggested. Item B is component technology development. In general,

this should be phased with the completion of item A. However, there are some areas such as high temperature electronics which must be advanced regardless of the chosen architecture. Item C in the program is for load management related research. This activity is phased with the completion of system architecture definition. A start date of March 1993 and a period of performance through January 1996 is recommended. Item D is the test and demonstration phase. In order to provide for a reasonable setup time for testing, the panel recommends a start date of October 1995 and a conclusion of December 1996. Item E, Modeling/Simulation, can be conducted throughout the entire program. Modeling/Simulation milestones of validated model increments which can be used to support other program segments are strongly recommended. To support system and component testing, for example, the program should set a target of having an initial analytical model or component model developed by June 1993 and a final model completed around January 1995.

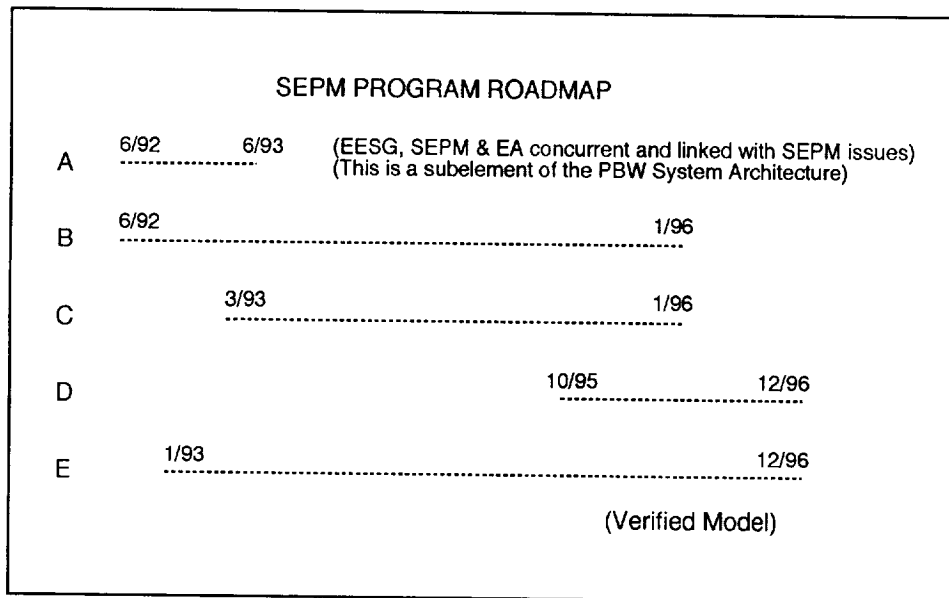

- A) System Architecture Definition
- B) Components Technology Development
- C) Load Management Related Research
- D) Test and Demonstration
- E) Modeling/Simulation

Figure 3.4. SEPM Program Roadmap

The panel's efforts were concluded by discussions of a specific set of questions which were posed by workshop planners. Is the power-by-wire program designed properly to prove technology readiness? The panel feels that the program will not

reduce the risks to the point of customer acceptance but it will quantify those risks. By carrying out the program, the government will better understand the technology risks and will develop approaches to address these risks. However, the panel does not think that the program is adequate to sell the technology to the customer.

What changes should be made? The panel concurred that the program should include as much testing, and in particular flight testing, as possible. The panel also recommends focused studies to determine the system configuration. The fundamental issue in the panel's opinion is sufficient testing to obtain performance numbers. With respect to the flight test, from the SEPM perspective any test bed would be reasonable. The test vehicle should be representative of the commercial aircraft. If the power system is new, we recommended the flight of at least one channel. If specific major components (load management unit) were new, those components should be flight tested.

Should the level of technology in this program consider a fully redundant power system? Yes. And, should it consider built-in test capability? Yes, but the extent of BIT is an issue for the panel. The government needs to determine requirements for cost-effective BIT.

Should the program focus on technology readiness for 1995 or beyond (2005)? The focus of the SEPM panel evaluation was the 1995 time frame. This was one of the guidelines that the panel set initially.

Will the results of this program support simpler aircraft certification? No, the panel does not think so. It was recommended that the customer and the FAA should be partners in all phases of the program to improve the acceptance process.

The last item considered by the SEPM panel was the relationship between fly-by-light and power-by-wire. How are they dependent on each other? The panel's answer is that flight-by-light does not improve or reduce the need for complete EME testing on the electrical power system of the aircraft. There are EME issues that fly-by-light technology will not affect. Fly-by-light technology will help in the control wiring and the control interfaces. However, electrical power must be distributed throughout the aircraft and will be subject to EME considerations.

### 3.2.2.3. Summary of SEPM Findings

#### SEPM Panel Discussion Main Points

- There was concern regarding establishing a technology roadmap without having a properly defined system architecture or requirements.
- There was also concern about architectural issues such as: distributed or centralized load management, load control authority and location, design methodology, and systems integration.
- The general feeling is that the customer will not be ready to accept 20 kHz power by 1996. In addition to technological uncertainty, the impact on the maintenance infrastructure would be too great.
- Proper system architecture definition is a critical need.
- Loads other than the electromechanical actuators should be given consideration. The environmental load will probably be the biggest load in this aircraft.
- Subsystem specifications should be examined and in some cases be revised.
- There should be close FAA involvement throughout the design and qualification phases to facilitate certification.

#### Summary of Discussions

- **Wire and Cable/Connectors**  
The first component technology to be considered was wire and cable. Development needs in the wire and cable area included specification of grounding schemes for hybrid systems and wire/cable diagnostics. An innovative concept was discussed to reduce weight and volume by integrating the signal cable with the power cable for routing to the actuators and other equipment. For connectors, high power connectors, connectors for the integrated power / signal cable, and revised standards were perceived as needs. Wire, cable, and connector issues would need to be addressed in cooperation with the EESG, EME, FTA, EA, and OSS groups.
- **Switching Components**  
The second area to be addressed was bus and circuit switching, including electromechanical, solid state, and hybrid technologies. Switching devices are

presently available, depending on the selected power type. Ratings for these devices were listed. Switching-related issues include the definition of “smart” (intelligence requirements, needs and capabilities of smart switches); zero crossover switching for ac devices; control interfaces (discrete, data bus, fiber optic); sizing (realistic continuous and overload power levels); and the anticipated thermal environment. These issues should be coordinated with the EESG, EME, EA, OSS, and SID groups.

- Circuit/System Protection

The next technology area was system and circuit protection. Protection includes preservation of system integrity and aircraft wiring. Types of protective devices include circuit breakers, fuses/current limiters, solid state power controllers (SSPC), hybrid (solid state/electromechanical) power controllers, electromechanical power controllers (EMPC), diodes, and remote control circuit breakers (RCCB). Circuit protection needs include cost reduction, component standardization, and autonomous operation. The issues include wire protection with nonstandard power types, frequency of occurrence and protection from high impedance failures, corona, load accommodation, regenerative power, expense, cost/benefits analysis, thermal environment, and diagnostic and built-in test requirements. Coordination will be needed between the EESG, EME, and EA groups.

- Load Management

Load management consists of electrical load on/off control. Automatic load management may include load shedding and staggered load turn-on, which is performed automatically as a function of flight phase or emergency condition. Integration and coordination issues were numerous, and they include control/power architectures, system design (source and load requirements), redundancy (channelized vs. modular), processing capability (how much, what type, where, speed, redundancy), interfaces, software, control algorithms, throughput, levels of autonomy, interface with Vehicle Management System (VMS), system integration, prioritization of loads for load shedding, flight control requirements, diagnostics and built-in test needs, reliability (single point failure), negative impedance, location of the point of regulation, “dirty” and “clean” power requirements, and packaging. These issues will require significant integration between the EESG, EME, EA, OSS, and SID groups.

- Power Conversion

Power conversion issues included system architecture (centralized vs. localized), “up” conversion, and variable frequency concerns. Coordination will be needed with the EESG, EME, and EA groups.

- System Issues  
System issues were also identified, and they include designing for certification, determination of power type, number and capacity of ground and aircraft power sources, number and type of interfaces, environmental requirements, control integration, packaging concepts, commonality of electrical specifications, customer acceptance, handbooks, powering of other MEA electrical loads, and the level of built-in test.

#### General Requirements Recommended by SEPM

- SEPM Functions
  - Power sensing
  - Power control switching
  - Power protection
  - Power processing
  - Information Processing (status, crew inputs, data interface)
  - System protection
  - Fault isolation and reporting
  - Load management (sequencing, sharing, shedding)
  - Circuit protection
  - Load information (current and voltage of loads)
- Flight and Ground Testing Recommended Power Quality, Stability, EME, Fault Injection
- Fully Redundant Power System
- Built-In Test
- Standardized Parts

#### Open Issues Identified by SEPM

- Thermal Management
- Standards
- Dynamic Load Management Under Emergency Conditions



- Redundancy Required
- Reliability
- Architecture
- Power Distribution for Flight-Critical PBW Components
- Built-In Test Specifics
- Voltages and Frequency of Power
- Autonomy of Control
- Load Requirements
- Regenerative Power Requirements
- Environmental Requirements
- EME Requirements
- Interfaces to Ground Services

#### Recommendations by SEPM

- Tradeoff study to determine specific architecture configuration
- Define test requirements
- Flight test

#### Requirements Not Addressed by SEPM

- Failure modes
- Maintenance/installation requirements

Chairperson, Lisa McDonald, presented the SEPM final summary report at the workshop closing plenary session. Viewgraphs used for this presentation are contained in Appendix E.

### 3.2.3. Electric Actuators (EA) Panel

#### 3.2.3.1. Introduction

The Electrical Actuators (EA) panel was chaired by Edward Beauchamp of Allied Signal and James Mildice of General Dynamics. Mary Ellen Roth, NASA LeRC, acted as deputy and Ed Withers, RTI, served as coordinator. The panel members were:

NAME	ORGANIZATION
Ed Beauchamp	Allied-Signal (Chairperson)
Jim Mildice	General Dynamics Space Systems (Co-chairperson)
Mary Ellen Roth	NASA Lewis Research Center (Deputy)
Ed Withers	RTI (Coordinator)
Arun K. Trikha	Boeing Commercial Airplane Group
Dick Crocco	General Electric Aircraft Controls
Ralph Alden	Lockheed Aeronautical Systems Co.
Edwin L. Mangelsen	Martin Marietta
Scott Gerber	Sverdrup (NASA Lewis Research Center)
Mark Davis	Moog Inc.
Pete Neal	Moog Inc.
Joe Tecza	Mechanical Technologies Inc.
Oleg Wasynczuk	Purdue University
Ted Carr	Honeywell Inc., Electro-Components
Ed Stevens	Parker Bertea
Bob Carman	Rocketdyne
Irving Hansen	NASA LeRC
John D. Stilwell	Sundstrand

The EA panel meeting began with the members listing items of importance that should be addressed. Following is the original list of topics.

- Electromechanical actuators - jam conditions/response
- Electrohydraulic actuators - low temperature
- Need to look at all types of electric actuators without concentrating on one type
- Definition of electric actuators

- Dealing with electromechanical actuator start transients
- Define the duty cycle
- Thermal management
- Redundancy requirements
- Mechanical complexity of electromechanical actuators
- Hostile environments
- System interaction between actuators
- Electric actuator specifications are not the same as hydraulic specifications
- Portability—do not use special purpose components...too expensive
- Adapt packaging for special conditions (in a wing, etc.)
- Reliability
- Control partitioning
- Allow room for emerging technologies
- Commercial vs. military (life cycles, requirements, specifications)
- Power source
- Force fight
- Military to commercial transition

Later in this report, the above topics have been regrouped and expanded based on the discussions that took place during the workshop. Many of the issues were discussed and either recommendations were made, issues were listed for other groups, or questions were defined that will need to be answered through testing, experimentation, or other means. Overall, the outlook for electric actuator technology is good for the FBL/PBW program. There is a fairly straightforward path toward the implementation of EA technology for FBL/PBW and the panel does not anticipate that there are technology problems which would prevent successful completion of the program.

### 3.2.3.2. Points of Discussion

#### Control Partitioning

- A question was raised about whether control would be centralized or distributed. This must be decided by the system architects.
- A question was raised about whether the primary flight control computer should be considered as a part of the electric actuators or as a part of a higher level system. It was decided that for this program, the flight controller needs to be outside the electric actuators, but for other aircraft, this may differ.
- On a related note, “smart” and “dumb” actuators were discussed. One item that emerged is that there is no good definition of a smart or dumb actuator, and that in reality, there is quite a spectrum between the two.
- The choice of actuator and the control partitioning will be affected by the architecture of the power and control system. A decision will need to be made whether to combine power and control or to have two different systems. A recommendation was made to have both a power and control circuit. In addition, it was suggested that the power circuit could be used as a backup for the control signal in the event of control circuit failure. A cost/benefit analysis of this potentially more reliable configuration should be conducted by the system architects.

#### Packaging

- Local environment conditions (size/weight allowed, etc.) will affect the unit packaging.
- Packaging will reflect thermal management and local environment control design decisions.
- The choice of packaging could be modified by EMI considerations if actuators must be shielded to limit EM radiation. Alternatively, shielding could be provided within the aircraft.
- For ease of maintenance, it is desirable to package the actuator and controller as a single unit. However, the choice of system architecture could dictate that separate units be employed; for instance, the actuator controls could be part of the flight management computer. Furthermore, the reliabilities of the actuator and controller could differ sufficiently that replacement on different schedules would be required.

## Portability

- When examining Electric Actuators, the designer must consider using generic rather than special purpose components, if possible. This will reduce cost during the procurement phase as well as during the maintenance phase.
- By reducing the number of separate components that make up an electric actuator (the actuator itself, its controller, etc.), it will be easier and cheaper to procure, and will be easier to install in new aircraft. However, there is a tradeoff in reliability since the electronics tend to be less reliable than the mechanical components, and thus may need to be replaced or updated separately and/or more often.

## Power

- The number of actuators that will be operated at one time must be defined to determine the type and amount of power that will be needed.
- Requirements such as frequency response, maximum and normal force/power requirements, and duty cycle must be determined early in the aircraft design. This will allow determination of peak and normal power requirement, thus affecting the choice of actuators (input and output power requirements, packaging (thermal management), and power distribution systems.
- If a force fight situation arises, power requirements may drastically increase.
- Power conditioning requirements must be determined for actuators. For actuators requiring relatively clean power, a choice between incorporating power conditioning within the actuator and incorporating conditioning with the power management function must be made. The responsibility for this design decision must be shared by the electric actuator designer, the power management designer, and the system architecture/integration engineers.
- As a minimum power conditioner, electric actuators will need to include some type of circuit protection.
- The issue of power control was discussed. It was decided that the SEPM should have primary control, but that each actuator should be able to shut off power if a problem is detected.
- Regenerative power was discussed and several issues were raised. Use of regenerative power must be coordinated with SEPM. It is possible to build electric actuators that dissipate, store, or return power. The selection of

which are used will affect packaging and thermal management of the actuator. This decision will also be affected by the fault tolerance requirements and the system architecture.

- For the current program, the type of power available (frequency, voltage, etc.) will need to be coordinated with the SEPM group. Recommendations were made to plan on accepting any type of power provided and convert it locally to the form needed by the actuator.
- The issue of start transients from electric actuators was raised. This should be a consideration for SEPM as well as the actuator designer.

### **Redundancy Requirements/Force Fight**

- Redundancy needs to be considered at several levels, starting at the power/control distribution system. If power and control are transmitted over different circuits, consider designing each circuit to handle both power and control. This would allow either circuit to provide both services if one of the two is damaged.
- When designing an electric actuator based system, consideration must be given to operation after a failure. This includes the behavior of the individual actuator (does it freeze in position, or free float), as well as the ability of other (redundant?) actuators to override the failed actuator or take its place.
- There were comments about the difficulty of designing fully redundant systems and the FAA's desire to avoid potential single points of failure in flight-critical systems. This further led to questions about the need for redundancy and re-examination of the FAA's requirements for redundancy.
- For redundant systems, the ability of the electric actuator to work with mechanical or other backup systems must be considered.
- For override or conflict situations (force fight), the effects of this on power requirements and thermal management as well as structure and the forces it can withstand must be considered.
- On a related note, jam conditions behave much the same as a force fight. However, any safety features to handle actuator jams need to be designed so that they do not cause unexpected or undesired actions during a force fight.

## Reliability

- The use of separate or combined power and control circuits for actuators could influence system reliability. If separate circuits are used, the power circuit could also serve as a backup for the control signal.
- The mechanical complexity of electro-mechanical actuators will be a primary driver of the system's reliability.

## Requirements/Uses for Electric Actuators (EA)

- The specifications needed to design an electric actuator differ from those needed to design a hydraulic or mechanical actuator. The differences between the two should be examined carefully. In light of these differences, airframe manufacturers should be advised on appropriate specifications for electric actuators. Some important aspects that need to be included in the specification are the duty cycle, frequency response, normal force, and maximum force requirements.
- Similarly, the replacement/maintenance requirements are different for electric actuators. The life-cycle/maintenance specifications should be re-examined.
- Design decisions between direct drive actuators and hydraulic actuators could arise. The cost benefit tradeoff which guides such design decisions must be guided by accurate, clearly written specifications.
- The technology to apply electric actuators to commercial aircraft is available, but appropriate electrical actuator specifications must be developed. The current specifications for hydraulic actuators are not appropriate.
- The FBL/PBW program should consider a range of appropriate electric actuator technologies and be limited to just one technology.
- The electric actuator technology needs to be considered in the context of how it can best be employed in an aircraft as opposed to simply replacing conventional hydraulic actuators on a conventionally designed aircraft. A suggestion was made for a paper study to evaluate this question.
- The FBL/PBW program should not rule out accommodating emerging technologies.
- A proposal was made to consider Electric Motor Drive (EMD) units as a separate item from other electric actuators. This was motivated by the difference between requirements for continuous speed motors and duty-cycle type actuators.

## Risk Sharing/Technology Development and Testing

- Although electric actuator technology exists, it has not been extensively tested and approved for commercial use. Electric actuator technology is being advanced and tested in a number of DoD programs but is not in widespread use.
- Approaches which reduce the potential risks inherent in electric actuators as well as the business risks involved in transitioning to their use should be identified.
- Electric actuator technology must be examined for potential safety problems.
- Some manufacturers are concerned that the payoff is too small compared to the risk associated with electric actuators. A thorough trade study of the potential payoffs could aid technology acceptance.
- NASA should consider sharing the technology development risks with other programs. As an example, the NASA program could use available military transport test beds for the FBL/PBW program. Some of the newer technology has been implemented in military test aircraft, but has not yet been flight-tested. NASA could provide funding for flight testing.
- One aspect of distrust for electric actuators stems from a lack of confidence in the central electrical system. A failure of the electrical system could disable all aircraft controls.
- For testing, electric actuators will have to be flown on test aircraft with backup systems. Therefore, at least in the early testing stages, the electric actuators will need to perform similarly to the current backup systems. Use of the capabilities of electric actuators that goes beyond current systems will have to wait until a higher level of confidence has been achieved.
- For flight test activities, the aircraft of choice must be appropriate for electric actuators. A decision will need to be made about the features that will drive this decision. At a minimum, the test bed will need to provide a platform in which electric actuation issues may be addressed and in which new technologies may be explored.
- During testing, a step should be to replace current hydraulic motors with electric motors, or with electro-hydraulic actuators.
- Although fly-by-light could be implemented for electric actuators, it is not necessary for initial flight testing.



- A recommendation was made to conduct ground testing on actuators for the rudder, spoilers, and aileron, but only to conduct flight test for the aileron actuator. This was based on the idea that aileron and elevator actuators are mechanically similar and flight critical. To reduce costs, the rudder and spoiler actuators could be ground tested.
- The flight test bed should be representative of a commercial airplane, and in deciding which platform to use, consideration should be given to specifications, power available, packaging required, EMI, control system requirements, and other design factors relevant to commercial aircraft.
- Flight tests should be conducted as if FAA certification was to be obtained. This would provide a basis for identifying the types of problems that would be encountered during an actual certification.

### **System Interaction of Different Actuators**

- An issue was raised about the interaction of different electric actuators operating within a single aircraft. There are power considerations (such as the potential simultaneous need for maximum power in several actuators), considerations for interference between the actuators, and considerations for the mechanical interaction between actuators (e.g., the elevator and the elevator trim actuators).

### **Thermal Management**

- The number of actuators that will be used at one time is an item that must be specified in order to make thermal management plans. This is also a power management question.
- The local environment must be defined to build in capability for heat dissipation. This will also affect system packaging.
- If a force fight situation arises, heat will need to be dissipated that may exceed design parameters.
- Low temperature conditions must also be considered. Electro-Hydraulic Actuators (EHA) may fail in low temperatures or may require drastically higher current levels.
- The conventional design approach for low temperature conditions is to allow a small current to flow in the actuator to keep it warm. However, if a small current keeps it warm, a normal or maximum current may cause a burn out, or the maximum current will limit the maximum power output.

- The thermal management system must handle dynamically changing local conditions such as takeoff from an equatorial base, cruise at high altitude in low temperatures, and landing in sub-arctic regions. This will affect the packaging design dramatically.

### **3.2.3.3. Conclusions**

#### General Requirements Recommended by EA

- Demonstrate aileron, rudder and spoiler on ground
- Demonstrate aileron in flight
- Flight test vehicle must be civil transport

#### Open Issues from EA

- Regenerative power
- Electric motors
- Smart/dumb actuators
- Redundancy
- Certification
- Load requirements for actuators
- Thermal management

#### Recommendations by EA

- Integrate demonstration with other programs (non NASA)
- Change all electric to more electric

#### Requirements Not Addressed by EA

- Actuator network architecture (distribution of control and power)
- Interface standards

- Redundancy requirements
- EME requirements
- Failure modes
- Full complement of actuators and motors for electric aircraft
- Environmental
- Maintenance/installation requirements

Chairperson, Ed Beauchamp, presented the EA final summary report at the workshop closing plenary session. Viewgraphs used for this presentation are contained in Appendix E.

### 3.2.4. Electrical Engine Starter/Generator (EESG) Panel

#### 3.2.4.1. Introduction

The Electrical Engine Starter/Generator (EESG) panel was chaired by Richard Rudey of Sundstrand. Thomas Jahns, General Electric, acted as co-chairperson. Linda Burrows, NASA LeRC, served as deputy and David McLin, RTI, served as panel coordinator. The panel members were:

<b>NAME</b>	<b>ORGANIZATION</b>
Richard Rudey	Sundstrand (Chairperson)
Thomas Jahns	General Electric (Co-chairperson)
Linda Burrows	NASA Lewis (Deputy)
David McLin	Research Triangle Institute (Coordinator)
Eric Moon	Allied Signal
Bill Murray	Douglas Aircraft
Clarence Severt	Wright Laboratories
Eike Richter	General Electric
Brij Bhargava	Ashman Consulting
Anami Patel	General Electric

The EESG panel met to discuss the following issues related to the incorporation of EESG systems into commercial passenger aircraft:

1. Technology needs definition
2. Technology readiness assessment
3. A roadmap for the introduction of the technology, and
4. Issues that need to be addressed before EESG technology can be integrated with other aircraft systems

#### 3.2.4.2. Technical Framework

The panel was presented with a block diagram of a proposed EESG system (see Figure 3.5) and asked to decide which of the components should be considered to be a part of the EESG. The panel identified the following components:

- The starter/generator (S/G)
- The generator control unit (GCU), and
- The bidirectional converter (BDC)

For purposes of discussion by the panel, EESG systems were assumed to include Auxiliary Power Units (APU) as well as main engine starter/generators, since in an all-electric aircraft, the APU would most likely be electrically started and would also have to supply electrical power to start the main engines.

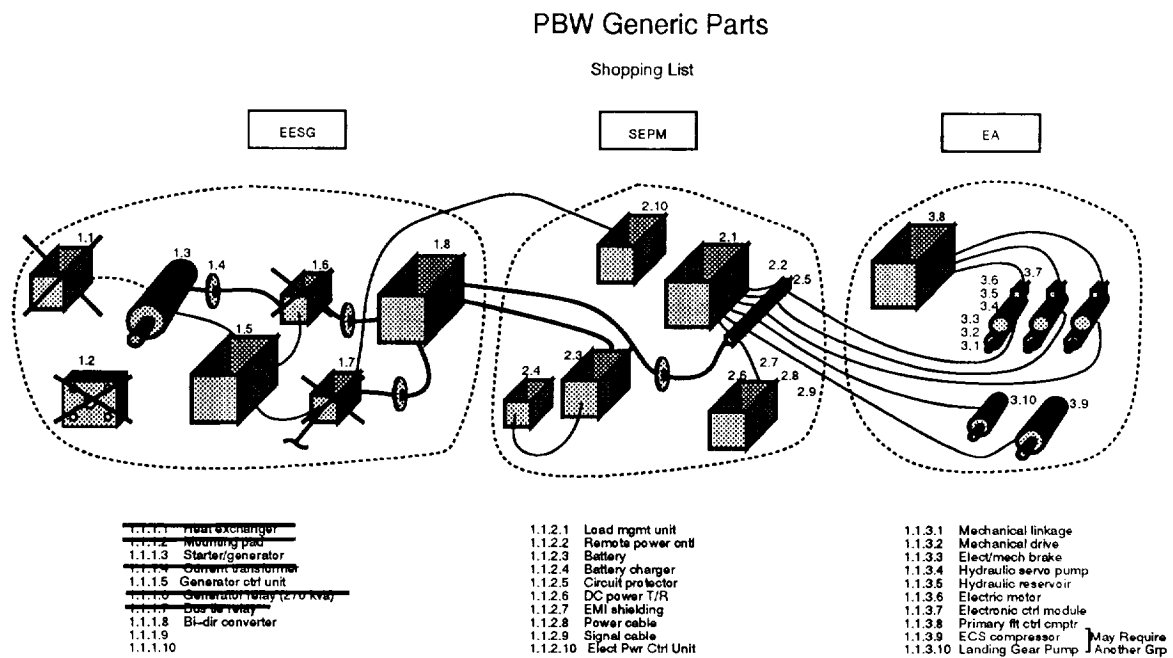

Figure 3.5. PBW Generic Parts - EESG

Power levels for both APU and main engine S/Gs were established to be:

Component	Power Level
Main Engine	250 - 375 KVA
APU	150 - 225 KVA

These power levels were based on estimates of the total electrical load needed for both starting and in-flight operation of an all-electric aircraft. The APU power

level reflects the fact that in twin-engine aircraft operating over water, the APU will be required not only to supply power to critical flight loads, but also have enough additional capacity to restart a main engine if required.

#### **3.2.4.2.1. Starter/Generator Partitioning**

An S/G is composed of two major units: the gas turbine and the electrical machine. In starter mode, the electrical machine acts as a motor which is used to spin the gas turbine for startup. In the generator mode, the electrical machine operates as a generator that is driven by the gas turbine.

Viewing the S/G as a composition of two separate machines allows a further subdivision to be made which distinguishes between internal or integrally mounted starter/generators and externally mounted starter/generators.

In an internally mounted starter/generator, the electrical machine is an integral part of the S/G and may share the same shaft and some of the bearings with the gas turbine. Removing the S/G would require the removal of both the gas turbine and the electrical machine as a unit.

In an externally mounted S/G, the electrical machine is connected to the turbine either directly to the turbine shaft or through a gear box. With this type of installation, the electrical machine can be removed from the aircraft without removing the turbine.

This gives a total of four S/G categories that were considered by the panel:

- Internally mounted main engine starter/generators
- Externally mounted main engine starter/generators
- Internally mounted APU starter/generators
- Externally mounted APU starter/generators

Only the electrical machine component of the S/G was addressed by the panel. In the following sections, S/G refers to the electrical machine portion of a starter/generator.

For each of these categories, as well as for the generator control unit and the bidirectional converter, the panel completed a component requirements definition worksheet that recorded the panel's consensus on several technical issues related to these components. Figures 3.6 to 3.11 are the component requirements worksheets developed by the panel.

### Component Requirements Definition Worksheet

NASA FBL/PBW Workshop

WBS No. <input style="width: 30px;" type="text"/>	Part Identity <input style="width: 150px;" type="text" value="Generator Control Unit"/>	
Technical Requirements	Shape/Envelope	Industry Data
What is the expected application/location? <i>Adjacent to converter</i>	Sealing Factor 	Who are interested/potential suppliers? <i>Same as S/G</i>
What are thermal/cooling needs? <i>Not as severe as converter or machine</i>		Capacity 
What is the electrical capacity/efficiency range? <i>Several hundred watts</i>		What is the development lead time? <i>24 - 36 months 36 - 48 months</i>
What are the expected shock/vibration limits? <i>Compatibility with engine environment</i>		Are there any major cost/risk concerns? <i>Hi density packaging is expensive</i>
What are the signal types/parameters? <i>Must interface with FADEC, POW mgmt. and flight control computer</i>		Would commonality emphasis pay off? <i>Very important to maximize cost-effectiveness</i>
What is the expected MTBF? <i>720,000 hrs.</i>	Estimate in Inches	Are there any critical end-user issues? <i>Physical location and thermal management</i>
Are there BIT or special maintenance issues? <i>Advanced diagnostics/monitoring desirable</i>		Should interface standards be written? <i>Yes - Communications</i>

Figure 3.6. Generator Control Unit

### Component Requirements Definition Worksheet

NASA FBL/PBW Workshop

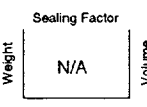
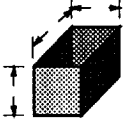
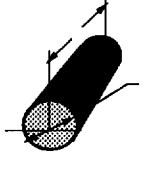

WBS No. <input style="width: 50px;" type="text"/>	Part Identity <input style="width: 150px;" type="text" value="Bidirectional Converter"/>	
<b>Technical Requirements</b>	<b>Shape/Envelope</b>	<b>Industry Data</b>
What is the expected application/location? <i>Close to S/G machine consistent with thermal limitations</i>	Sealing Factor Weight   2-4 lb./KVA   Volume	Who are interested/potential suppliers?  <i>Same as for S/G</i>
What are thermal/cooling needs? <i>Liquid (fuel) cooling preferred air preferred by airframes</i>		What is the product availability status?  <i>Not available today</i>
What is the electrical capacity/efficiency range?  <i>250 - 375 KVA &gt; 90%</i>	Capacity 	What is the development lead time?  <i>24 - 36 months 36 - 48 months</i>
What are the expected shock/vibration limits?  <i>Must live in engine environment</i>	 Estimate in Inches	Are there any major cost/risk concerns? <i>Power semiconductor availability in hermetic packages</i>
What are the signal types/parameters?  <i>Nothing special</i>		Would commonality emphasis pay off? <i>Would benefit from modularity</i>
What is the expected MTBF?  <i>Requires high fault tolerance 10 - 20 hrs. - series element</i>		Are there any critical end-user issues? <i>Fuel cooling poses difficulties</i>
Are there BIT or special maintenance issues? <i>Strong diagnostics/monitoring needed</i>		Should interface standards be written?  <i>Yes - Electrical interface</i>

Figure 3.7. Bidirectional Converter

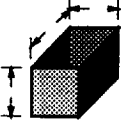

### Component Requirements Definition Worksheet

NASA FBL/PBW Workshop

WBS No. <input style="width: 40px;" type="text"/>	Part Identity <input style="width: 95%; border: 1px solid black;" type="text" value="APU S/G - Internally-Mounted"/>	
Technical Requirements	Shape/Envelope	Industry Data
What is the expected application/location? <i>APU - on board - tail section</i>	<div style="display: flex; flex-direction: column; align-items: center;"> <div style="display: flex; align-items: center; margin-bottom: 10px;"> <div style="writing-mode: vertical-rl; transform: rotate(180deg); font-size: 8px; margin-right: 5px;">Weight</div> <div style="border: 1px solid black; padding: 5px; text-align: center; margin: 0 10px;">                     Sealing Factor                      3-5 lb./KVA                 </div> <div style="writing-mode: vertical-rl; font-size: 8px; margin-left: 5px;">Volume</div> </div> <div style="margin-bottom: 10px;">Capacity</div> <div style="text-align: center; margin-bottom: 10px;">  </div> <div style="text-align: center;">  </div> <div style="margin-top: 10px; font-size: 8px;">Estimate in Inches</div> </div>	Who are interested/potential suppliers? <i>Sundstrand Allied-Signal Lucas, P &amp; W</i>
What are thermal/cooling needs? <i>Fluid cooling</i>		What is the product availability status? <i>Not available today</i>
What is the electrical capacity/efficiency range? <i>150 - 225 KVA &gt; 90 - 95%</i>		What is the development lead time? <i>36 months P-type 48 months flight qual</i>
What are the expected shock/vibration limits? <i>Same as current specifications</i>		Are there any major cost/risk concerns? <i>Tech risks with high speed high temp</i>
What are the signal types/parameters? <i>N/A</i>		Would commonality emphasis pay off? <i>Not a critical issue</i>
What is the expected MTBF? <i>2 - 3 x powerstage</i>		Are there any critical end-user issues? <i>ETOPS start reliability</i>
Are there BIT or special maintenance issues? <i>N/A</i>		Should interface standards be written? <i>Yes</i>

Figure 3.8. APU S/G - Internally-Mounted

### Component Requirements Definition Worksheet

NASA FBL/PBW Workshop

WBS No. <input style="width: 40px;" type="text"/>	Part Identity <input style="width: 90%; border: none;" type="text" value="APU S/G - Externally-Mounted-Shaft Direct (no GB)"/>	
Technical Requirements	Shape/Envelope	Industry Data
What is the expected application/location? <i>Same as conventional APU</i>	Sealing Factor Weight <span style="font-size: 2em;">}</span> Volume 3-5 lb./KVA Capacity	Who are interested/potential suppliers? <i>Sundstrand Allied-Signal Lucas, P &amp; W</i>
What are thermal/cooling needs? <i>Not as severe as internally mounted unit - liquid cooled</i>		What is the product availability status? <i>Not available today, but close</i>
What is the electrical capacity/efficiency range? <i>150 - 225 KVA &gt; 90 - 95%</i>		What is the development lead time? <i>24 months P'type 36 months flight qual</i>
What are the expected shock/vibration limits? <i>Same as current specifications</i>		Are there any major cost/risk concerns? <i>High rotor speeds</i>
What are the signal types/parameters? <i>N/A</i>		Would commonality emphasis pay off? <i>Not a critical issue</i>
What is the expected MTBF? <i>Lower req. than for internal</i>		Are there any critical end-user issues? <i>Accessibility better for ext. - mount challenges assoc. with lubeless system</i>
Are there BIT or special maintenance issues? <i>N/A</i>		Should interface standards be written? Yes
		Estimate in Inches

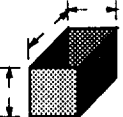
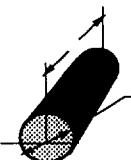
Figure 3.9. APU S/G - Externally-Mounted-Shaft Direct

### Component Requirements Definition Worksheet

NASA FBL/PBW Workshop

WBS No. <span style="border: 1px solid black; padding: 2px;">1.1.1.3</span>	Part Identity <span style="border: 1px solid black; padding: 2px;">S/G, Main, Internal</span>	
Technical Requirements	Shape/Envelope	Industry Data
What is the expected application/location? <i>HBPR Eng.</i>	Sealing Factor 	Who are interested/potential suppliers? <i>Eng. Manuf.</i>
What are thermal/cooling needs? <i>Engine cooling sharing</i>	Capacity 	What is the product availability status? <i>PDR</i>
What is the electrical capacity/efficiency range? <i>250 - 375 KVA &gt; 90 - 95%</i>		What is the development lead time? <i>36 months P'type 48 months flight qual</i>
What are the expected shock/vibration limits? <i>Per Eng. Spec.</i>		Are there any major cost/risk concerns? - <i>cost should be less than Xterm</i> - <i>technical development</i>
What are the signal types/parameters? <i>N/A</i>		Would commonalty emphasis pay off? <i>f of application</i>
What is the expected MTBF? <i>2 - 5 x Eng. Reqs.</i>		Are there any critical end-user issues? - <i>reliability</i> - <i>repair accessibility</i>
Are there BIT or special maintenance issues? <i>Maintenance Free Cooling System (exception)</i>	Estimate in Inches	Should interface standards be written? <i>Yes</i>

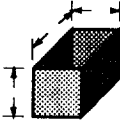
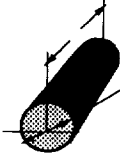
Figure 3.10. S/G, Main, Internal

### Component Requirements Definition Worksheet

NASA FBL/PBW Workshop

WBS No. <span style="border: 1px solid black; padding: 2px;">1.1.1.3</span>	Part Identity <span style="border: 1px solid black; padding: 2px;">S/G, Main, External</span>	
Technical Requirements	Shape/Envelope	Industry Data
What is the expected application/location? <i>HBPR Engs. gear box</i>	Sealing Factor Weight <span style="border: 1px solid black; padding: 2px;">3-5 lb./KVA</span> Volume Capacity	Who are interested/potential suppliers? <i>Bendix, Westinghouse, Lucas, Sundstrand, Auxilec, Shinko, Lelan</i>
What are thermal/cooling needs? - <i>Incr. MX capacity</i> - <i>liquid cooling</i>		What is the product availability status? <i>None</i>
What is the electrical capacity/efficiency range? <i>250 - 375 KVA (total) (90 - 95%)</i>		What is the development lead time? <i>12-24 months P'type 36-48 months flight qual</i>
What are the expected shock/vibration limits? <i>Per Current Specs.</i>		Are there any major cost/risk concerns? <i>Normal</i>
What are the signal types/parameters? <i>N/A</i>	 Estimate in Inches	Would commonality emphasis pay off? <i>t of application</i>
What is the expected MTBF? <i>20,000 hours (total) 7,000 starts (?)</i>		Are there any critical end-user issues? - <i>handling</i> - <i>cabling</i>
Are there BIT or special maintenance issues? <i>None</i>		Should interface standards be written? <i>Mech./Fluid</i>

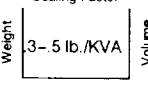
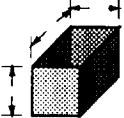
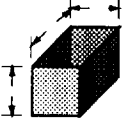
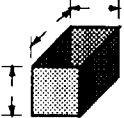
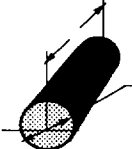
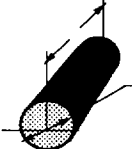
Figure 3.11. S/G, Main, External

### **3.2.4.3. Technology Needs Definition**

The panel identified the technical objectives for each of the major EESG components and then identified technology developments needed to meet those objectives. These are discussed for each of the major EESG components: the S/G, the GCU, and the BDC.

#### **3.2.4.3.1. Starter/Generators**

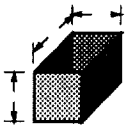
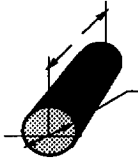
##### **3.2.4.3.1.1. Technical Objectives**

The major technical objectives identified for S/Gs were:

- High reliability/fault tolerance
- High low speed torque
- High speed (peripheral velocity)
- High power density
- High temperature tolerance
- Affordability

Achieving high reliability was considered to be particularly important, especially for internally mounted starter/generators. The goal would be to have such a machine no less reliable than existing electrical starters. This requires that the reliability of the electrical portion of an internally mounted S/G be two to five times greater than that of existing equipment, since a failure in the electrical portion of an internally mounted S/G would be considered a failure of the entire unit.

High low-speed torque is necessary for overcoming oil viscosity and other friction losses when engines are started in cold weather. This implies that certain motor electrical designs will be preferable to others.

High peripheral speed results in better generator electrical performance in a smaller package for a given power level.

High power density translates into smaller and lighter S/Gs, important considerations for aircraft applications. The panel believed that power densities in the range of 0.3 - 0.5 lb/KVA were achievable.

High temperature tolerance will be necessary, especially for internally mounted S/Gs, which will be exposed to higher temperatures than externally mounted S/Gs. Higher temperature materials will also result in a longer service life and improved reliability.

#### **3.2.4.3.1.2. Needed Technology for S/G Systems**

The panel identified the following technology improvements that will be needed to attain the technical goals:

- Improved thermal management
- No-lubrication bearings (for APUs)
- High temperature magnetic materials
- High temperature insulation
- Fault-tolerant machine configurations
- Improved rotor dynamics

Since future EESGs will be producing higher power levels than is required on current aircraft, better thermal management technology will be required to deal with the increased waste heat. Improvements could be based on advances in current air-to-air heat transfer systems, on newer vapor-cycle cooling systems, or on liquid cooling systems, or combinations of these technologies.

No lubrication bearings will reduce weight and maintenance by removing the components associated with existing oil-based lubrication systems.

Since internally mounted S/Gs will be exposed to the higher temperatures inside the APU or main engine for long periods of time, better high-temperature materials will be needed to ensure that the S/G will meet its high MTBF goals. These include better high-temperature insulation and improved high-temperature magnetic materials.

Since the cost of repairing an internal S/G will be relatively high, there is a need to develop fault-tolerant configurations for S/Gs. The use of switch-reluctance technology is believed to offer benefits in this area.

Improved rotor dynamics may be necessary, particularly for internal S/Gs which are directly mounted on the turbine shaft and which therefore rotate at the same high speeds as the turbine.

### **3.2.4.3.2. Generator Control Units**

The generator control unit, as its name implies, is responsible for controlling the operation of the S/G. The panel identified the following technical objectives for the GCU.

#### **3.2.4.3.2.1. Technical Objectives for Generator Control Units**

- High reliability/fault tolerance
- Strong diagnostics and monitoring
- High Bandwidth between GCU and S/G
- Low EMI susceptibility
- High controller independence
- Affordability

Since the GCU is critical to the operation of the overall EESG, it must be very reliable. The panel believed this would require some degree of fault tolerance in the GCU.

The panel also believed that the GCU should have extensive S/G monitoring and diagnostic capabilities. This would be the primary means of monitoring the health of the S/G by maintenance personnel, as well as providing the information needed by the GCU to effectively control the S/G.

Real-time control of the S/G by the GCU will require high-bandwidth channels for sensing and control signals. This is required because of the short control loop delay needed to adequately control the S/G.

Since the GCU is a critical component that will contain microelectronic components, such as microprocessors, it must be adequately shielded from EMI which is generated by other EESG components and by outside sources.

Independence refers to the ability of the S/G and GCU to operate autonomously and not have to rely on components external to the EESG for proper operation under normal and adverse conditions. This will improve the overall robustness and fault isolation of the power generation and distribution system.

Finally, as with other EESG components, these technical characteristics must be provided at a cost that will be acceptable to users.

#### **3.2.4.3.2.2. Needed Technology for GCU Systems**

The panel identified needed technology improvements in the following areas:

- Size and weight reduction
- Advanced hardware/software architectures for enhanced controller fault tolerance
- Improved self-diagnostics and protection features
- Sensor elimination algorithms
- Advanced control algorithms for improved APU dynamic response
- Higher computing power (higher speed digital signal processors)
- Improved thermal management

Since the GCU will be installed on an aircraft, its weight and size should be minimized as much as possible.

The panel believed that the very high reliability required of the GCU will in turn require the development of advanced fault-tolerant hardware and software architectures. As with similar efforts in fly-by-wire aircraft control systems, the use of these types of architectures will pose significant problems related to their certification.

Failures of sensors can be difficult to detect, especially in an integrally mounted S/G where access is difficult. Thus, reducing the number of sensors will help minimize problems caused by sensor failures. This may require the development of algorithms which can infer the values of operating parameters that are not directly sensed from other operating parameters that are directly measured.

Complex and sophisticated algorithms will be needed to control the S/G. This, coupled with the high-bandwidth, low latency control loop processing, will require the use of high performance processors, such as special purpose digital signal processors.

As with other EESG components, improved thermal management is needed to handle the high power levels entailed in a power-by-wire aircraft.

#### **3.2.4.3.3. Bidirectional Converters**

Bidirectional converters will be responsible for converting power from/to the S/G depending on its mode of operation. The panel identified the following technical objectives for bidirectional converters.



#### **3.2.4.3.3.1. Technical Objectives**

- High reliability and robustness
- Minimization of EMI generation and susceptibility
- Insensitivity to mounting location
- High-power density
- High efficiency
- Affordability

The BDC must be very reliable and robust since it is responsible for converting the power produced by the S/G into a form which can be handled by the power distribution system. A failure in the BDC would prevent the S/G from operating in either the starter or generator mode, neither of which is desirable from an operational viewpoint.

Since power conversion may involve switching high currents and voltages at high frequency, particular attention must be paid to the suppression of EMI generated by the converter. Soft switching technology was seen to be of value in reducing EMI.

The BDC should be insensitive to mounting location so as to minimize losses between the S/G and the BDC. For an integral S/G, this would require the BDC to be located as close to the engine as possible. This will affect the design of the BDC cooling system.

High-power density is desirable to reduce the size and weight of the BDC. High efficiency is desirable for reducing the amount of waste heat produced by the BDC. Finally, the BDC needs to be affordable if it is expected to find a place in commercial aircraft.

#### **3.2.4.3.3.2. Needed Technology for Bidirectional Converters**

The panel identified the following technology improvements for bidirectional converters:

- Improved thermal management
- Hermetic power switch packaging
- Improved passive components (capacitors and inductors)

- EMI tolerance and EMI suppression (e.g., soft switching converters)
- Self-protection capabilities (robustness)
- Improved current and voltage sensors
- Low-weight buswork

As with other EESG components, better thermal management will be needed because of the higher power levels handled by the BDC in a power-by-wire aircraft.

Better components need to be developed, particularly in the areas of power switch packaging and passive components. Improvements in these areas will help achieve the goals of higher power density and increased efficiency.

As described above, the BDC is potentially a large source of EMI because it switches high currents/voltages at high frequencies. Soft switching technology may help improve the EMI suppression characteristics.

Since the BDC is a critical component in the overall EESG, the provision of self-protection and recovery from unusual operating conditions will be important. This will require improved current and voltage sensors.

Finally, since power must be distributed throughout the aircraft, low-weight distribution bussing will be desirable for reducing the overall weight of the distribution system.

#### **3.2.4.4. Technology Readiness Assessment**

##### **3.2.4.4.1. Overall Assessment**

In general, the panel noted that many of the components needed to demonstrate a working EESG system were already in various stages of development. The configuration and power level of the EESG system to be demonstrated will have a significant influence on the amount of time and money needed to develop a working system. An integrally mounted S/G operating at high speeds and capable of supplying high electrical power would require the highest funding and involve the greatest technical risk. Less risky and less expensive would be the development of an externally mounted S/G operating at lower power and driven through a gear box.

Table 3.3 summarizes the panel's consensus on technology readiness for the various EESG components and configurations considered by the panel.

Table 3.3. Technology Readiness Assessment

TECHNOLOGY READINESS ASSESSMENT

	Present Stage of Development	Technology Readiness % (Note 1)	Months to Prototype (Note 2)	Months To Flight-Worthy Hardware (Note 2)
Main S/G, Ext. Mtd.	Detailed Design	80%	24	36
Main S/G, Int. Mtd.	Preliminary Design (for Mil. Engine)	70%	36 (assumes existing centerline)	48 (assumes existing centerline)
APU S/G, Ext. Mtd.	Analysis & Concept Demo HW (prelim. design at lower KVA)	90%	24	36
APU S/G, Int. Mtd.	Preliminary Analysis	< 50%	36	48
Bidirectional Converter	Detail Design w/Concept Demo HW (bench demo)	80%	24-36	36-48
Generator Control Unit	Detail Design w/Concept Demo HW (bench demo)	70%	24-36	36-48

Note 1: Readiness for NASA Program - view from today's perspective

Note 2: Months from now - assuming technology starts now.

Also assumes funding availability - projections based on technology assessment

### 3.2.4.5. Roadmap

The panel proposed the roadmap shown in Figure 3.12 for the development of a working demonstration system. As shown in the roadmap, work on the EESG system cannot be started until the power management and distribution system requirements have been established.

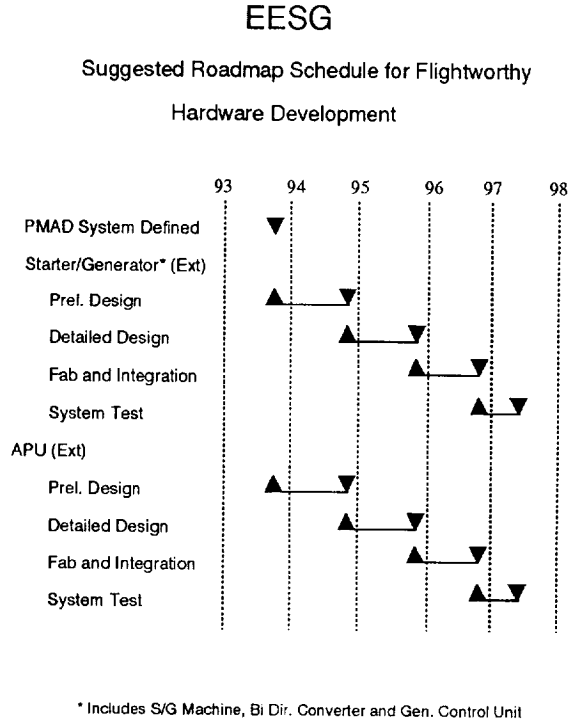

Figure 3.12. EESG Suggested Roadmap for Flightworthy Hardware Development

### 3.2.4.6. System Issues

Since the EESG must operate in the context of the overall power distribution system, requirements on the overall power distribution system will affect the design of EESG components. The panel identified three major interactions that will be important for EESG design:

- The effects of power quality & EMI requirements on component weights

- tight requirements on all power distribution (i.e., MIL-STD-704E, -461) can heavily penalize EESG and loads with heavy filtering requirements
- separation of utility and control power deserves consideration
- issues of components versus system EMI certification
- Effects of power distribution architecture on EESG complexity and weight
  - architectures requiring EESG to develop multiple power types (400 Hz, 28 Vdc, ?) will add weight penalties to EESG and distribution network
- Effects of overload requirements
  - traditional overload requirements of 3 p.u. short circuit current for 5 seconds deserve reconsideration because of EESG size and weight penalties
  - overload requirements under ground and flight idle conditions also need careful scrutiny to avoid unnecessary EESG weight penalties
- Critical effects of thermal management issues on EESG component locations, sizes, and weights

These system issues will have a significant effect on the overall design of the EESG.

### **3.2.4.7. EESG Summary of Findings**

#### Requirements Recommended by EESG

- Power Ratings
  - 250-375 KVA Main Engine
  - 150-225 KVA APU
- Near term 400Hz
- 2000 +
  - Hi Voltage DC, Variable Freq., Hi Freq.
- MTBF
  - If internal mount, 2-5 times engine requirements

– If external mount, 20,000 Hrs., 7000 starts

- No gear box
- Liquid cooling for external mount
- Share engine cooling for internal mount
- Fault tolerant controller
- Self-diagnosis and protection
- Advanced control algorithms
- Current shock and vibration specs

#### Open Issues Identified by EESG

- Is NASA's goal the best way for system to evolve or is it tech readiness 1996?
- Degree of risk NASA will take? (Demonstrate low-power EESG from existing components or fully-integrated internal S/G?)
- Certification requirements for internally mounted S/G and APU
- Frequency/voltage for future system
- AC/DC, Hi Voltage/Lo Voltage, single vs. wild vs. variable frequency
- Power quality standards
- Power distribution architecture
- Overload requirements
- Mounting
- Weight
- Thermal management
- EMI

### Recommendations by EESG

- 400Hz near term

### Requirements Not Addressed by EESG

- Failure modes
- Maintenance/installation requirements

Chairperson, Thomas Jahns, presented the EESG final summary report at the workshop closing plenary session. Viewgraphs used for this presentation are contained in Appendix E.

### 3.3. Fault-Tolerant Architectures (FTA) Panel

#### 3.3.1. Introduction

The FTA session was chaired by Dagfinn Gangsaas of Boeing Defense & Space. Dan Palumbo of NASA Langley's System Validation Methods Branch was the Session Deputy and Charlotte Scheper of the Research Triangle Institute was the Session Coordinator. The table below lists the FTA session participants.

<u>NAME</u>	<u>ORGANIZATION</u>
Dagfinn Gangsaas	Boeing Defense & Space (Chairperson)
Dan Palumbo	NASA LaRC (Deputy)
Charlotte Scheper	RTI (Coordinator)
Steve Young	NASA LaRC
Carl Elks	NASA/AVRADA
Kevin Driscoll	Honeywell SRC
Larry Yount	Honeywell ATSD
Gerald C. Cohen	Boeing HTC
Jay Lala	Draper Lab
Allan White	NASA Langley
Chris Walter	Allied-Signal ATC
Ben DiVito	ViGYAN, Inc./NASA Langley
Dick Fletcher	GE Aircraft Engine Controls - Lynn
Rick Butler	NASA Langley - SVMB
Joe Schwind	Air Line Pilots Assoc.
Tim Felisky	Rockwell AM&ASD
Ken Albin	Computational Logic Inc.
John Rushby	SRI International
Ken Martin	Rockwell/Collins
Henry Schmidt	Moog Inc.
Ted Scarpino	GE Aircraft Controls, Binghamton
Graham Bradbury	Sundstrand Aerospace, Rockford
John McGough	Bendix Flight Systems, Teterboro
Jose F. Aldana	Rockwell International NAA
Pete Saraceni	FAA Technical Center
Jim Treacy	FAA National Resource Specialist
Kang G. Shin	Univ. Michigan, Ann Arbor

In order to inform panel members on FBL/PBW technology and to foster inter-panel communications, Gangsaas requested that Andrew Glista and Louis Feiner brief



the panel on FBL/PBW technology. Glista discussed the FOCSI program and Feiner described a study to evaluate the benefits of PBW technology for a more electric civil transport aircraft.

The objective of the FBL/PBW Architecture element of the program is to devise, analyze, develop, fabricate, and test an optically based fly-by-light/power-by-wire architecture consisting of redundant optical sensors, fault-tolerant fiberoptic signaling, fault-tolerant computers, and a secondary power management and distribution system appropriate for advanced transport aircraft. The approach will be to determine system level requirements, synthesize an architecture meeting the requirements, and validate that the architecture meets the requirements by applying design for validation concepts throughout the design process. This will entail close coordination with LeRC personnel on the optical sensors and power-by-wire technology to be used in the architecture. The Fault-Tolerant Architecture (FTA) Session of this workshop considered the following topics in addressing the adequacy of the NASA plan and identifying open issues and requirements: 1) design practice/methods, 2) processing architectures, 3) certification/validation, 4) interprocessor communication architectures, 5) sensor/actuator communication architectures, and 6) demonstration goals and plans. Several panel members accepted the opportunity to make presentations to the panel. Jay Lala of C.S. Draper Laboratories discussed the attributes of a FBL architecture and presented a proposed architecture. Kevin Driscoll from Honeywell discussed failure modes, determinism, synchronization, and redundant network topologies. Rick Butler of NASA LaRC discussed reliability validation problems associated with fault recovery and common mode failures of which HIRF upsets are a threat.

### **3.3.2. NASA Plan Adequacy and Program Recommendations**

The goal of the NASA program should be to increase U.S. competitiveness in flight-critical system design and certification. The FTA working group concluded that NASA can achieve this goal by bringing FBL/PBW building blocks, architectures, and certification technology to maturity by 1996 and by providing estimates of the quantitative benefits that these would provide. The building blocks are fiberoptic networks that can support flight-critical, ultrareliable application requirements; electronic actuators; power system management and distribution; electro-optical interfaces; optical sensors; connectors and cables, and fault-tolerant computers that can meet  $10^{-9}$  reliability requirements for flight-critical functions and that have an optical backplane. The certification technology will need to include certifiable design methods that enable the development and use of integrated systems. These meth-

ods include formal methods for specification and verification and new methods for partitioning and allocating functions across the system components.

These conclusions are supported by the move toward more computer-controlled critical functions in the airplane, the perceived economic benefits from integration, the need for enabling methods to produce integrated architectures for critical applications, and the increasing cost of validating and certifying systems. Therefore, it is essential that the following components be addressed in the FTA work breakdown structure (WBS) of the NASA program:

1. design practice/methods
2. processing architectures
3. certification/validation
4. interprocessor communication architectures
5. sensor/actuator communication architectures, and
6. demonstration goals and plans

To ensure that the FTA WBS is focused toward achieving its goals, the original plan as presented to this working group was amended to include both the creation of a baseline system and corresponding requirements and an initial trade study that will be continued as a series of checkpoint studies throughout the life of the program. This amended plan is illustrated in Figure 3.13.

This plan starts with the identification of a set of target airplanes and the corresponding requirements. Then using various tools and methods for system architecture design, a full-up system for the target airplane would be designed. This system design would only be a paper design. At the same time, a baseline fly-by-wire-and-hydraulics system would be defined. With these two system definitions, a trade study will be conducted for a benefits assessment that can demonstrate the gains and losses. The next step is to decide which pieces of the system need to be tested, either in the laboratory or in flight. The selected subsystems would then be implemented and tested in the lab or on the airplane. During the course of these activities, issues in methodology and tools and architectural issues such as integration, partitioning, scheduling, communication protocols, etc., would be highlighted and studied.

The trade study called for in this plan is a very important task because this study will help define the preferred architecture or architectures that should be pursued, and identify the preferred component technologies. Another aspect of this trade study is that it is not only a very significant up-front activity, but that it has to

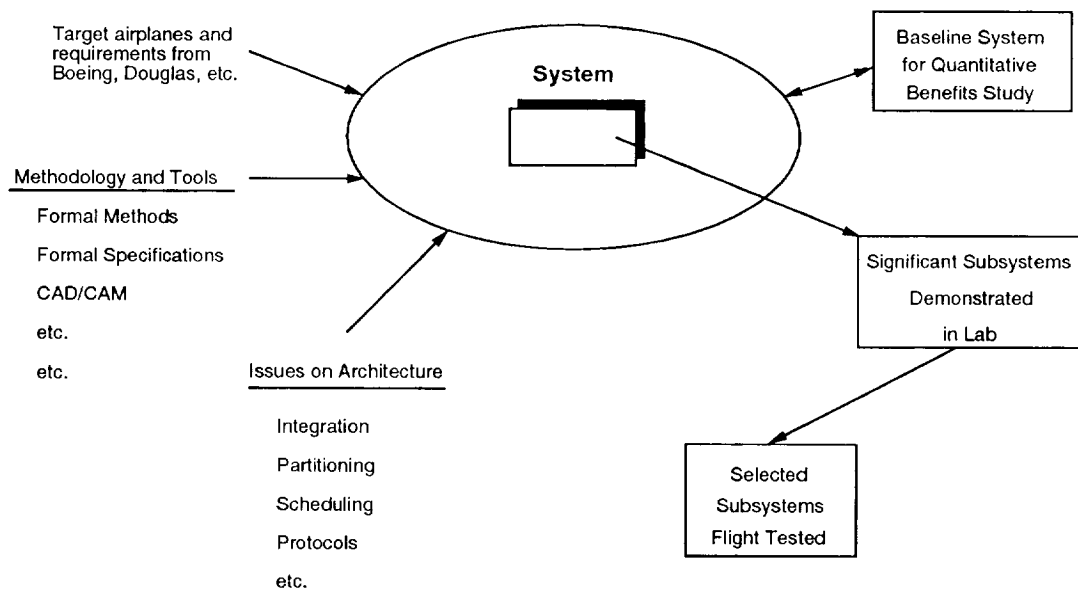

Figure 3.13. Amended Plan for FTA WBS of NASA Program

be continued in the form of checkpoint studies throughout the life of the program. These checkpoint studies will allow the program to check that it is continuing to take the correct approach and that the architecture is still on track with evolving system requirements. This activity will be very important in insuring high-quality results from the program.

### 3.3.3. Requirements

The challenge of the FBL/PBW program for the fault-tolerant architecture is to define a FBL architecture that accomplishes the following items:

- Exploits FBL strengths and avoids FBL weaknesses.
- Resolves issues pertaining to integration versus fault containment and integration versus timing.
- Integrates FBL with PBW.

Two areas in particular will present major challenges for designing the architecture: data distribution networks and the photonic sensors and interfaces. Additionally,

requirements will have to be developed for requisite levels of redundancy and redundancy management, integrating power-by-wire with fly-by-light and both with other subsystems. Two critical issues that must be addressed with respect to power-by-wire are that generating a large amount of electrical power will become flight critical and that the new actuators will have new failure modes and effects.

It is necessary that this activity come up with a data distribution network (e.g., data bus) that has the required reliability and fault tolerance, but is not too costly. There are many options available today, but it isn't clear to the architecture community that there is an existing bus that meets the requirements and stays within cost constraints. It is important to get industry consensus on the definition: the industry can not afford to again buy or support three or four different types of buses if they're not all required.

A similar need exists to decide on the types of sensors and interfaces to be used. There are many prototypes, and not all of them can be brought along. This program needs to make the decision so that standards can be established. Different suppliers can then produce the requisite sensors, insuring sufficient supply at affordable cost. This program should also provide the demonstrations and data that are needed for program managers to feel comfortable that this technology can be used with reasonable risk.

In addition to defining a FBL/PBW architecture, it is also necessary that the program demonstrate one or more flight-critical functions in flight and develop the following enabling technologies:

1. industry standards
2. certification
3. FBL/PBW system design approach
4. ground and airborne test facilities

The development of an overall certification approach is required from this program. Such an approach will make it easier to transition the technology into commercial aviation. In fact, it is important that technologies or approaches which cannot be certified be identified and avoided. The program will require FAA participation from the beginning to insure a valid, workable certification approach.

The development of the architecture and the enabling technologies relies on the resolution of a number of issues that fall into four categories: certification, system, fly-by-light, and power-by-wire. Each of these categories is discussed in the following section.

### **3.3.4. Open Issues/Requirements:**

#### **3.3.4.1. Certification Issues**

The program needs to develop an overall certification approach that will specify how to certify a FBL/PBW system. This approach must address the following issues:

- Architectural techniques and building blocks must be certifiable.
- Certifiable design methods to enable injection of integrated systems must be developed. Such methods include formal methods, methods to partition functions, and methods of validating integrated systems.
- The increase in the number and the possible integration of critical functions.
- The cost of certification and validation.
- How to accomplish and verify and validate fault containment when integrating functions.
- How to verify and validate recovery mechanisms.
- How to protect against common mode failures and how to verify and validate the protection and recovery mechanisms.
- The effects of power functions becoming critical functions with the use of power-by-wire technology.
- The introduction of new failure modes.
- How to manage redundancy with or without a fallback to an alternate technology.
- The need for improved validation and verification methods.
- The need for a certifiable FBL/PBW system design approach.

#### **3.3.4.2. System Issues**

The system issues comprise five areas: existing issues not yet resolved for fault-tolerant, fly-by-wire architectures; integration of critical functions; validation and verification; standardization; and human factors. Of the existing fault-tolerant issues, the most critical are determining required redundancy levels, devising validatable

redundancy management mechanisms, quantifying recovery parameters to required levels to assess recovery probability, defining failure modes, and issues of synchronous versus asynchronous operation and deterministic versus nondeterministic behavior. The other major existing system issues are the man-machine interface; verification and validation; the cost of development and validation; tradeoffs between performance, safety, and reliability; and cross-channel communications synchronization.

In the area of integrating critical functions, the issues are which functions to integrate, how to integrate them, and how to overcome cultural obstacles to function integration. Candidate functions include primary flight controls, electrical power management, engine control, load alleviation, primary flight instruments, and equipment for low visibility operation. Methods of integration have to be developed that allow function partitioning and allocation while maintaining the integrity requirements and lowering the cost of system development and operation. Cultural obstacles arise from the current view of the system architect as one who designs the bus for subsystem designers to use. In this view, each subsystem requires a specialist, precluding the ability of one system architect to integrate all subsystems.

The validation and verification issues comprise two areas: validation of requirements and verification that the system meets the validated requirements. These issues are not yet resolved for FBW systems, but the need for design methods and processes that address these issues will become even greater with increased integration of critical functions and the use of FBL and PBW technology. Some of the questions that are still unanswered are:

- Is  $10^{-9}$  validatable?
- Are current approaches worthwhile?
- Have we ever had a handle on failure modes?
- How are verification assumptions identified and validated?
- How can recovery mechanisms be verified and validated?
- How can protection and recovery mechanisms for common mode failures be verified and validated?

Current methods for analyzing a system's behavior in the presence of faults include the use of Markov models to estimate system failure probability. An underlying assumption in these models is the independence of faults. A growing concern with common mode faults (i.e., those faults that arise from a common source and are

hence not independent) has highlighted the need for carefully examining the analysis assumptions, particularly with respect to design faults and EME-induced faults. Thus, a key validation question is whether EME destroys the independence assumption, and if so, whether a photonic backplane restores and guarantees this assumption. Some additional common mode issues are:

- Does the field intensity of EME vary from processing site to processing site? How do the EME source and the aperture of the airplane affect which components are affected? Experimentation is required to characterize EME effects.
- There is some experience to suggest that whether or not individual system components suffer an upset when subjected to a common mode fault is data-dependent.
- What is the probability of recovering to the same error space in more than one faulty processor?
- There is no way to show independence for design faults.

Independent of the origin or persistence of the fault, recovery from the fault does not stop with the disappearance or removal of the physical fault. It also includes removing any error induced by the fault. An evaluation problem arises in defining and estimating the transition rates to and from the recovery states of the model. In general, recovery strategies can be devised that can be demonstrated in the lab, but the parameters that describe them in an analysis model cannot be quantified.

Given the infeasibility of life-testing complex systems or measuring many of the parameters of importance to their analysis, it is increasingly less viable to produce a system and then try to verify it; it is necessary to produce a method for designing the system that assures validation and verification, and ultimately, certification.

Another important system issue that should be addressed by this program is standardization of components, protocols, and languages. New components are being developed, and the only way to achieve feasible costs is to increase the volume produced. Therefore, specific component designs should be selected, built, and validated for the production of an adequate competitive supply. In particular, standards need to be set for a data bus based on required protocols and topology, electrical-optical back planes and other electrical-optical interfaces, and optical sensors. Finally, standards will also help assure the needed levels of reliability from individual components.

The final area of system issues is human factors. Human factors has to come in as a requirement at the front end. Adding a WBS for human factors should be considered; although NASA's role is not to develop human factors requirements, it

is necessary for NASA to establish these requirements. The areas of system design where human factors play a significant role are the pilot controller, the control response characteristics, display information, envelope protection, degraded operation, the number of control modes, and pilot involvement in redundancy management. At the architectural level, human factors impact the following areas:

- At what level of detail does the state of the system as a result of degradation have to be communicated?
- If it is required that all information be passed back to the pilot, what additional requirements exist for system communication activity?
- What functions are where, how do they communicate, and how do they interact?

Further, human factors requirements can create different failure modes, requiring that the architecture be designed to identify and respond to those failures.

#### **3.3.4.3. Fly-By-Light Issues**

The fly-by-light issues arise by discriminating a fault-tolerant fly-by-light architecture from current fault-tolerant fly-by-wire architectures. The fly-by-light architecture will not be a direct replacement, although the system issues discussed above will still apply. The following additional issues will arise:

- The potential increase in bandwidth is a difference that may lead to integrating I/O and functions.
- Differences in shielding weight changes the architecture; there is a desire in current FBW systems to put processors as close as possible to sensors/actuators.
- There is a potential for fundamentally different failure modes.
- FBL is point-to-point rather than multiple drop: fiber can't be multiply tapped without transmission loss.
- A wide dynamic range exists: different for near and far locations, different protocols.
- Electrically passive optical transducers are a source of big weight savings, can mitigate the point-to-point problem, and produce a tendency to go to centralized.



- The design driver is weight savings, but the pieces of the system have to be arranged differently because of different advantages and disadvantages.
- There are differences in connectors, such as no wipe clean, maintenance, and alignment problems.
- There is no experience to draw on in designing FBL architectures. There is not the same body of knowledge as exists for FBW: don't know how to use FBL in terms of its failure rates and failure modes; don't know how to maximize strengths and minimize weaknesses.

In view of these issues, the following questions should be answered by NASA:

1. What specific issues or architectural components should NASA be looking at? If passing critical data to the flight control computer across a distributed system becomes necessary, then there is a need for a high-speed, critical bus. What communication protocols are required? What will the message mix be with respect to size and criticality?
2. Given that the military has examined some of the relevant issues in their programs, how can this program benefit from that experience? What are the differences between military and commercial aircraft, and are they really significant?
3. Does physical distribution increase safety and/or impact weight?
4. Given that a proliferation of critical functions seems likely, do we have the knowledge required to design and verify the systems?
5. What are the metrics that should be considered in determining whether and to what degree to integrate functions? What are the tradeoffs between sensor integration and potential loss of data across multiple functions?

#### **3.3.4.4. Power-By-Wire Issues**

It was felt by the FTA working group that power-by-wire had the potential for a more revolutionary impact on the architecture than fly-by-light. One of the key issues in power-by-wire is power generation, and the group sees the development of a starter/generator as a critical issue for the whole NASA program.

A large part of the revolutionary impact of power-by-wire is that the complete electrical power system will become flight critical in the sense that large amounts of

power have to be supplied at all times. This is a different situation from today's airplanes that are based on hydraulic power with a battery to run the computers. Thus, there will be additional functions that have to be brought into the flight-critical region. With the electrical actuators and the power distribution system, there will be failure modes that are different from the current ones. The characteristics of hydraulic systems are well understood: how to bring them up, what happens under different failures, and how to deactivate them.

Depending upon the technology chosen for power generation and distribution, power-by-wire could result in a lot of internal EME. Power-by-wire may also provide the opportunity for and require more integration. Integration in turn will raise the issue of propagating faults from one subsystem to another. In addition, there will be timing issues and integration with power-by-light issues.

Therefore, the following items will have to be addressed:

- The increase in critical functions
- The cultural problems arising from integration and from functions becoming flight critical
- Advantages and disadvantages of function partitioning versus function integration
  - some degree of integration is expected
  - metrics are needed to guide decisions
- Advantages and disadvantages of physical distribution
- Power management system becomes part of the primary flight control system
- How to insure design correctness of larger, more complex critical systems
  - logical partitioning
  - physical partitioning
- Fault effects partitioning
- Functional coupling/allocation
- Redundancy management
- Quantifying benefits, such as increased reliability and reduced weight
- Tradeoffs between power input to actuators and power source options
- Thermal management

### **3.3.5. Requirements/Issues to be Resolved with Other Areas**

The architectural requirements and issues are tightly coupled with all other areas. Specification of FBL/PBW component characteristics and failure modes are particularly important to resolving the architectural requirements. The determination of redundancy levels for system components such as sensors and actuators have to be made with respect to vehicle structural requirements, control laws and aircraft operational modes, as well as the fault tolerance mechanisms of the architecture. Before communication network topology, protocols, and message characteristics can be specified, all subsystem requirements and acceptable levels of integration have to be worked out to resolve architectural issues of distributed versus centralized computing, function partitioning and allocation, and level of processing to be performed locally at sensor/actuator sites.

The resolution of the power-by-wire requirements is especially critical because the consensus is that power-by-wire will result in new critical control functions, which in turn may radically alter the computing architecture. The FTA group views the development of the starter/generator as crucial to the power-by-wire program.

Finally, the certification issues are relevant to all areas of the NASA program and their resolution must be addressed by all areas.

### **3.3.6. Conclusions and Discussion of Dissenting Views**

The members of the panel generally adhered to three views:

- NASA should produce an integrated, distributed FBL/PBW system design and demonstrate crucial parts of that system.
- NASA should concentrate on developing the methodology that is required before industry can build a validatable, certifiable FBL/PBW system.
- NASA should concentrate on a study process to develop demonstratable subsystems; i.e., more careful definition of system requirements, more planning studies, more trade studies, and more tracking of new subsystem developments to a system baseline.

It was suggested that one approach to coming to agreement on defining the program would be to identify the roadblocks that this program has to address. The following roadblocks were listed:

- How to maintain fault containment when integrating functions

- Integration versus timing allocation, scheduling
- High speed data bus: have an ARINC standard
- Kinds of sensors: definition
- Definition of redundancy management for power management and distribution (PMAD); also for EA
- Characteristics of individual devices undefined
- Impact of new FBL/PBW components on architecture, especially with respect to reliability
- Hybrid vs. purebred: what technologies are going to be available in timeframe
- Impact of degraded modes

A strong minority view is that no one person or group is smart enough to integrate all these subsystems. Partitioning, fault containment, synchronous and asynchronous techniques are all important, but what group is smart enough to do it for each subsystem? According to this view, the objective of the system architect is primarily to connect sensors to processors to actuators, giving the subsystem designers the greatest amount of flexibility. Therefore the following issues are the ones that should be addressed:

- What kind of bus is appropriate?
- What kind of protocols are appropriate?
- How can the bus be designed to be flexible enough for all subsystem requirements and designs?

According to this view, the study should focus on the bus design, especially with respect to identifying the requirements for the network with respect to the individual subsystem designers. This opinion is documented in a letter contained in Appendix F.

Since a majority of the participants were leaning toward the need for NASA to conduct a study prior to proceeding with particular architectural designs, the panel discussed the type of study required and the level of effort required for the study. Since some panel members favored bringing something into the lab as soon as possible and who argued that numerous paper studies would lose support, it was decided that the best approach would be a phased study; i.e., a continuous analysis to check that

the development of the candidate architecture stays on track with evolving system requirements, technology developments, and program goals. Thus, the study should be a program global activity that lasts throughout the program, with the level of effort starting out high and tapering off.

### **3.3.7. Summary of FTA Findings**

#### General Requirements from FTA

- Examine at least flight-critical function in-flight
- Pilot interface is part of system
- Power is flight critical with FBL/PBW

#### Open Issues Identified by FTA

- New failure modes with FBL/PBW
- Data acquisition/distribution network architecture
- Interface standards
- FBL/PBW component characteristics
- Certification approach
- Architecture
- Redundancy

#### Recommendations by FTA

- Develop representative target aircraft
- Define FBL/PBW functions and requirements
- Target costs and weight
- Define operational environment
- Conduct baseline benefits study

- Conduct trade study to determine preferred architecture

#### Requirements Not Addressed by FTA

- Maintenance/installation
- Workload for full system and flight test subset

Chairperson, Dagfinn Gangsaas, presented the FTA final summary report at the workshop closing plenary session. Viewgraphs used for this presentation are contained in Appendix E.

### 3.4. Electromagnetic Environment Assessment (EME) Panel

#### 3.4.1. Electromagnetic Environment (EME) Panel

The panel was chaired throughout the workshop proceedings by Richard F. Hess, Air Transport Systems Division, Honeywell, Inc., of Phoenix, Arizona. The NASA deputy for the panel was Felix L. Pitts, who was also co-chairperson of the FBL/PBW Workshop. Aubrey E. Cross of RTI served as panel coordinator. The panel was comprised of 20 members representing a broad practical experience background of expertise in EMI diagnostic methods/evaluations and analytical tools. The aerospace community was well represented on the panel by each member's affiliations with NASA, USAF, USN, FAA, major aircraft companies, academia, and independent research-support businesses. The panel members were:

<b>NAME</b>	<b>ORGANIZATION</b>
Richard Hess	Honeywell-ATSD (Chairperson)
Felix Pitts	NASA Langley (Deputy)
Aubrey Cross	RTI (Coordinator)
Celeste Belcastro	NASA Langley
Lawrence C. Walko	USAF Wright Lab
Rod Perala	Electro Magnetic Applications, Inc.
Dennis Baseley	USAF ASD/ENACE
Bruno Moras	Boeing Defense and Space
Calvin Watson	Boeing Commercial Air
Fred Heather	Naval Air Warfare Center
Thomas F. Trost	Texas Tech Univ.
Klaus P. Zaepfel	NASA LaRC
Peter Padilla	NASA LaRC
Michael Hatfield	Naval Surface Warfare Center
Gerry Fuller	CKC Labs
Mike Glynn	FAA Technical Center
John Polky	Boeing
Steven Pennock	LLNL
Rich Zacharias	LLNL
Andrew J. Poggio	LLNL

To provide a basis for panel discussions, Felix Pitts reviewed the NASA plan to develop an EME assessment methodology appropriate for FBL/PBW technology. The

approach to be taken will be to apply the Lawrence Livermore National Laboratory high-power microwave assessment technology to transport aircraft, to validate those models with experimental data, to develop a High Intensity Radiated Field (HIRF) assessment laboratory, to conduct HIRF laboratory experiments to determine effects in a redundant flight control computer, and to examine in-service fault data related to HIRF. The challenge, as noted by Jim Treacy in the keynote address, will be to demonstrate that EM modeling can provide a basis for reduced aircraft testing. Felix Pitts' viewgraphs are contained in Appendix C.

Following the presentation of the NASA plan for FBL/PBW EME effects assessment, panel members were allowed to present their perspective on EM modeling and testing. Rich Zacharias of LLNL gave a presentation entitled "EM Effects Assessment Options." He stressed the need for different measurement and analysis techniques for the HIRF spectrum above 400 MHz. Steven Pennock of LLNL gave a presentation entitled, "EM Coupling Calculations Using Temporal Scattering and Response (TSAR)." He discussed the features of the TSAR EM modeling system. The presentation was accompanied by a video tape on EM modeling and visualization.

Rodney Perala, Electro Magnetic Applications, Inc., gave a presentation entitled "Electromagnetic Analysis of Aircraft: State-of-the-Art Summary." After discussing the computational complexity of EM modeling to 40 GHz for aircraft, Perala emphasized the cost effectiveness of a high throughput, hardwired, multiprocessor to accelerate the intensive computation required for comprehensive EM modeling.

Peter Padilla of NASA LaRC reviewed the plans for the HIRF Laboratory to be developed under the FBL/PBW program. Michael Hatfield from the Naval Surface Warfare Center (NSWC) discussed low-power microwave testing with mode-stirred chambers. Thomas Trost of Texas Tech. University also discussed EM testing with mode-stirred chambers. The final presentation was by Gerry Fuller of CKC Laboratories, Inc. Fuller discussed EM testing in anechoic chambers and stressed the need for analytic modeling to provide insight to support testing and interpretation of test results.

Key observations made during these presentations were:

- HIRF Test Facility will use control laws for civil transport
- Modeling software tools need to be user friendly
  - need capability to suit needs of sophisticated user (EM Scientist)
  - need less complex capability to suit needs of more general user (non EM Scientist)



- Analytic modeling capability is needed to complement EM testing (provides necessary insight to understand test results and to determine what and how to test)
- With current modeling tools and computing capability it would require 10 years to model EM for an aircraft using brute force methods
- High-intensity testing can damage absorbing material used in chamber
- Testing in rectangular metal rooms does not represent aircraft, and results are not predictable
- Above 400 MHz different methods are required

After the presentations described above, panel efforts were directed toward assessing the NASA plan, the preferred methodology for analytic assessments, the priorities for extending analytic capability, the aircraft tests for experimental EM effects assessment, and the issues and recommendations which must be communicated to other technology areas.

The tasks for assessing the EME Technology associated with Fly-By-Light/Power-By-Wire (FBL/PBW) Technology were identified, consolidated, and prioritized. All of the technology-area requirements were addressed during the panel sessions and there were no items classified with a to-be-determined (TBD) status. Overall, EME assessment technology was identified as a high priority need for the aerospace community in the NASA LaRC Flight-Critical Digital Systems Technology Workshop, December 1988. Also, for EME technology to be most beneficial, it is critical that EME effects be considered during the conceptual definition and tradeoffs stage of the program.

It was determined that the goals and objectives of the NASA plan for EME Assessment Technology are realistic and the proposed schedule is supportable. The proposed host aircraft (LaRC ATOPS 737) is ideal for the program.

The objective of the FBL/PBW efforts in electromagnetics is to develop validated analytical and experimental assessment methodologies for EME effects. The EME assessment will consist of two components, analytical and experimental. Development of a baseline methodology, which applies the Lawrence Livermore National Laboratory (LLNL) weapons system High Power Microwave EME assessment to transport aircraft, is the approach to be taken. EME/aircraft interaction analytical modeling will be based on LLNL codes which use the three-dimensional, finite difference time-domain (3DFDTD) analysis. It was the consensus of the panel that 3DFDTD is the preferred methodology for computational electromagnetics. Panel discussions

were directed toward the adequacy and appropriateness of using the LLNL codes. Alternative analytic modeling codes were discussed. One 3DFDTD product, developed by Electro Magnetic Applications, was reported as potentially appropriate for the FBL/PBW EM assessment objectives. The LLNL codes were determined to be appropriate and adequate as baseline analytical modeling codes, provided that their technical capabilities are extended. The extensions, in order of priority, that were identified as necessary to fulfill the program objectives were:

1. Incorporate the full frequency range of HIRF environment,
2. Increase spatial resolution and object size,
3. Extend capability to model the statistical process associated with EM reverberation chambers,
4. Add the capability to handle dispersive media,
5. Add the capability to handle composite materials or anisotropic media,
6. Incorporate the thin slot/wire formalism, and
7. Add the capability to model multiconductor cable networks.

Other extensions were discussed and identified as desirable but not as important as those of the highest priorities. These improvements or extensions include: lumped parameter impedances, normalized fields, nested subgrids, injected currents for modeling lightning, ferrites/magnetic materials, nonlinear media for air breakdown, time varying material parameters, and late-time, low-frequency (Prony) techniques.

The panel recognized the importance of enhancing the user aspects of the codes. The need for modeling tools that do not require the user to be an EM scientist was noted by Jim Treacy during his keynote address. User friendliness, interfaces to computer-aided design tools, code decomposition appropriate for effective parallel computing, hardware accelerators, and code downsizing for personal workstations were the user-related topics that were considered important by the panel. Enhancing user-related features of the codes was ranked second in priority to the essential technical extensions.

The analytical assessments will be validated by experimental measurements conducted in laboratory facilities, on-ground aircraft tests, and aircraft flight tests. For the laboratory testing, which will be the initial testing phase, frequency range issues will be paramount. Benchmark test methods and alternate test methods will be employed, including an integrated lightning/HIRF/EMI approach and establishment of circuit susceptibility margins.

For the on-ground aircraft tests, which will support the follow-on flight test and code validation, the testing regime will be low-level swept fields (LLSF) and low-level swept coupling over an extended frequency range, and full level at the specific emitter frequencies chosen for fly-by flight tests. For the fly-by flight testing, the highest priority emitter proposed was the Voice of America (VOA), because of its higher radiated power in the appropriate frequency spectrum. Other proposed emitters in order of priority were airport VHF Omnidirectional Range (VOR) sites, and the NASA-Wallops Island radar sites. For the fly-by testing, it is necessary to identify a pass/fail criteria.

For the several FBL/PBW work areas, the EME panel communicated to the System Integration and Demonstration (SID) panel, for their consideration, the following four points: 1) hardening for EME effects is a system architectural as well as a box shielding issue; 2) consider the physiological/health effects relative to potential fields, particularly those caused by PBW; 3) identify and provide a list of existing tools and guidelines for other groups within FBL/PBW; and 4) the EME Assessment Technology Panel proceeded on the basis that spurious light sources, such as lightning, will not be a FBL threat.

Additional issues which the panel felt should be communicated to other areas were:

- Perceived benefits of FBL/PBW could be substantially compromised if EME effects are not taken into account during the tradeoff assessments that occur in the initial design stages.
- The philosophy for EME effects immunity could be substantially impacted by PBW (power switching could have greater EM effect than HIRF). A new design philosophy may be required for future systems, e.g., grounding.
- Optical sensor technology benefits are greatest for low-level sensors located in EM exposed regions such as the cockpit wheel well. Traditionally, actuator sensors that provide a relatively high-level signal which is transmitted over twisted, shielded pair medium have been relatively robust to EME and represent a diminishing return payback for optical sensor conversion.
- Analysis will play a more prominent role in developing and assessing EM immune designs and will be used in a complementary analysis/testing process.
- The potential benefits of optics relative to EME effects include:
  - inherent immunity over the life of the aircraft (i.e., elimination of shields and their maintenance, etc.

- independent of Faraday cage shielding
- inherent immunity over the frequency range where aircraft wiring is the dominant factor in EME effects
- Interaction between sensor technologists and EM engineers will be required to determine which sensors are most/least susceptible to high EMI levels in “dirty” areas such as the landing gear or the cockpit.

Thus, the tasks for assessing the EME technology aspects associated with validating the potential benefits of FBL/PBW were identified (validation of technically expanded analytical codes with experimental measurements), consolidated (laboratory measurements, HIRF modeling, on-ground aircraft tests and aircraft flight tests), and prioritized (priority given to extended technical capability for the analytic codes).

A final EME panel summary report was presented to all workshop participants by the panel chairperson, Richard Hess. Appendix E contains the viewgraphs used for this presentation.

### 3.5. System Integration and Demonstration (SID) Panel

#### 3.5.1. Leading Particulars

The System Integration and Demonstration (SID) panel was chaired by John Todd of McDonnell Douglas. Cary Spitzer of NASA LaRC served as deputy and Robert Baker of RTI served as coordinator. The 18 workshop attendees who participated in the SID panel sessions were:

<b>NAME</b>	<b>ORGANIZATION</b>
John Todd	McDonnell Douglas Aircraft (Chairperson)
Cary Spitzer	NASA LaRC (Deputy)
Robert Baker	RTI (Coordinator)
William Myers	GE Aircraft Engines
Ron Frazzini	Honeywell
Reuben Williams	NASA LaRC
Ramayya Mulukutla	GE Aircraft Engines
Gordon Hamilton	Douglas Aircraft Co.
Dave Whritenour	GE Aircraft Controls
Chuck Meissner	NASA LaRC
Peter Shaw	Northrop
Michael Baylor	Wright Labs/POOX
David Segner	AATD FT EUSTIS
Don Martin	Boeing
Bob Yeager	Wright Labs
Steve Cloyd	Wright Labs/P00C-2
Brian Hager	Wright Labs/P00S-3
John Lytle	NASA Lewis RC
William Kroll	Sundstrand

#### 3.5.2. SID Proceedings

Mr. Todd opened the session by reviewing the NASA FBL/PBW program plan elements and schedules. The stated objectives of the integration and evaluation element in the program plan are to integrate various FBL/PBW technologies and accomplish comprehensive laboratory evaluation and flight test of selected subsystems. Mr. Todd

also discussed the general topics that would be considered in the session. Some of the questions considered appropriate for panel discussion were:

- What interface standards, compatibility requirements, and inter-operability requirements are necessary for system integration?
- What critical attributes or concepts must be demonstrated to address technology risks, benefits, feasibility, certification, and transfer?
- What subset of avionics functions are sufficient for cost-effective, end-to-end flight test demonstrations?
- What additional ground and laboratory tests are required to demonstrate the FBL/PBW technology?
- What is needed to successfully implement the demonstrations?

Additional issues that were to be addressed were:

- Appropriateness and sufficiency of the NASA demonstration plan with respect to technology transfer, technology risks/benefits, and cost effectiveness.
- Integration requirements and issues that must be resolved with support from other workshop panels
- Integration requirements and issues that must be levied against areas associated with workshop panels

Cary Spitzer described the use of the Boeing 737-100 LaRC ATOPS 737 aircraft by the Advanced Transport Operating Systems (ATOPS) branch at NASA LaRC. The aircraft is 25 years old and has 3,000 flight hours. Plans call for the use of this aircraft for FBL/PBW flight testing and selected ground testing. It was noted that flight tests must be determined which will establish credibility for FBL/PBW technology while also satisfying LaRC ATOPS 737 safe flight policy and program budget constraints. Chuck Meissner, co-chairperson of the FBL/PBW workshop, discussed AIRLAB research at NASA LaRC and plans for use of AIRLAB laboratory system and subsystem integration test for the FBL/PBW program.

To acquaint SID panelists with PBW technology, John Todd arranged for SID panelists to join the PBW opening session during a presentation on PBW technology by Dick Quigley.

Initial panel discussions focused on determining the scope of the panel's effort; identifying items that would not be considered by the panel; identifying objectives, considerations, and constraints for the system integration efforts; and the need to identify factors that could have substantial impact on the FBL/PBW program plan. Items or questions identified for consideration by the panel were:

- What demonstration is necessary to convince airlines of technology readiness and effectiveness?
- What needs to be tested/demonstrated on aircraft?
- What needs to be tested/demonstrated on ground?
- Test facilities for ground test and the integration
- Test facilities for aircraft test and integration
- Testing standards
  - DO-160C
  - MIL-STD 810E

A demonstration methodology that was directed toward convincing the airlines to accept FBL/PBW technology was discussed. This methodology should assure that operational transparency, cost savings, good performance, and certificability are demonstrated. Cost savings should include both initial investment and direct operating costs which are highly dependent on dispatch reliability, reliability, maintainability, and supportability. To convince air transport manufacturers, the demonstration methodology should assure technology readiness, cost effectiveness, and aircarrier acceptance. Cost effectiveness, from a manufacturer's perspective, includes performance improvement; dispatch reliability, reliability, maintainability, and supportability improvements, manufacturability, and reduced certification costs. Aircarrier acceptance would include safety, initial cost, return on investment, and direct operating costs. The aircraft manufacturers must be convinced that the air carriers will buy the technology.

Although there was recognition of and concern for the impact of operational factors on the acceptance of FBL/PBW technology by airframers and air carriers, it was decided that there would not be sufficient time for the panel to consider control laws and the pilot vehicle interface. Accordingly, an assumption of operational transparency was the basis for the panel's discussions.

In the area of objectives, guidelines, constraints, and considerations; the following items were noted:

- Technology readiness
- Cost effectiveness of technology
  - Performance improvements
  - Reliability
  - Maintainability
  - Supportability
  - Manufacturability
  - Reduced certification costs
- Air carriers acceptance/desires
  - Initial costs
  - Return on investment
  - Direct operating costs
  - Safety
- Airlines consider electrical systems one of the larger maintenance problems on aircraft (connectors, etc.) If switch to PBW leads to more complex, bigger electrical system for PBW, how will demo convince airlines PBW is better?
- Ground demonstration should include pilot
- Demonstrations should address integration and operational concepts
- Different optical sensor and PBW technologies should be demonstrated
- Demonstration should be assertive/aggressive to address airframer/airline concerns
- Demonstration should build up incrementally to full level as opposed to all things at once
- Flight test must be large enough to be significant but small enough to be affordable
- More testing may be required for revolutionary technology
- A subset of a flight control system such as 2 spoilers and stabilizer for flight test was suggested



- Human factors are important and needs improvement in all areas from maintenance/aircraft servicing to pilot interface
- Airline participation will be important for technology transfer
- Can FBL and PBW be demonstrated separately rather than together?
- Cost of demonstration and testing

It was determined that demonstrations requiring flight testing of flight-critical functions or requiring an aircraft other than the LaRC ATOPS 737 would have substantial impact on program funding requirements. The potential need for flight demonstration of FBL/PBW technology within the propulsion system was identified by the panel as an item that could have substantial cost implications. Another aircraft or the installation of different LaRC ATOPS 737 engines could be required. The need for such a demonstration derives from the hostile environment (temperature, fuel, vibration, EME, etc.) offered by the propulsion system to FBL/PBW technologies. Finally, the potential need to flight test the selected EES/G was identified as an item that would impact demonstration funding requirements.

The panel identified the major propulsion, power management and distribution (PMAD), PBW, and flight control components. Table 3.4 lists these components.

To conduct integration and evaluation, the power system with loads, components in environments, fault tolerance, built-in test (BIT), degradation, and in-service conditions should be tested.

Tables 3.5 through 3.7 summarize other test related topics discussed in the panel session.

Tables 3.8 and 3.9 give the types of tests associated with ground and aircraft based testing that were discussed by the panel. The panel discussed equipment and facilities to conduct test. Items identified for ground tests are given in Table 3.10.

Additional topics of discussion were:

- Timetable for demonstrations based on technology availability
- Use of results from related non-NASA technology programs to reduce testing
- Demonstration of FBL and PBW separately
- Specific items to test or demonstrate
- Where tests are to be conducted

Table 3.4. Major Systems Components

PMAD	Propulsion	PBW	Flight Control	Loads
<ul style="list-style-type: none"> <li>- Power Conditioning Units</li> <li>- Electric Load Management Center</li> <li>- Solid State Power Controllers</li> <li>- Generator Control Unit                             <ul style="list-style-type: none"> <li>• Opt-elec interfaces, health monitoring</li> </ul> </li> <li>- Cockpit Panel</li> <li>- Cables, Connectors, Insulation, Shielding</li> </ul>	<ul style="list-style-type: none"> <li>- Starter/Generator</li> <li>- Optical Sensors                             <ul style="list-style-type: none"> <li>• Position</li> <li>• Temperature</li> <li>• Pressure</li> <li>• PBW rates</li> <li>• Vibration</li> <li>• Discretes</li> </ul> </li> <li>- Fuel Pumps</li> <li>- Fuel Valves</li> <li>- Actuators                             <ul style="list-style-type: none"> <li>• Nozzle</li> <li>• Thrust reversers</li> <li>• Compress</li> </ul> </li> <li>- Simit Anti-Ice</li> <li>- Electro/optical Converter - FADEC</li> <li>- Power Conditioning?</li> <li>- ACTIF Interface Hardware and Components</li> </ul>	<ul style="list-style-type: none"> <li>• PBW Actuation                             <ul style="list-style-type: none"> <li>- Flight Controls</li> <li>- EHA - Flight Critical</li> <li>- EMA - Non-Flight Critical</li> <li>- F/T Critical Fault Tolerant Dual Redundant                                     <ul style="list-style-type: none"> <li>• 2 elec. sources</li> </ul> </li> <li>- Actuator Controller Electronics                                     <ul style="list-style-type: none"> <li>• Opto-electric interfaces</li> </ul> </li> <li>- Optical Position (rate?) sensors</li> </ul> </li> <li>• Other Actuation                             <ul style="list-style-type: none"> <li>- Landing Gear</li> <li>- Doors</li> <li>- Nosewheel</li> <li>- Steering</li> <li>- Brakes</li> </ul> </li> </ul>	<ul style="list-style-type: none"> <li>• FBL Computers Autopilot/Autoland                             <ul style="list-style-type: none"> <li>- Optical Pilot Controls/Sensors                                     <ul style="list-style-type: none"> <li>• Rotary or linear position</li> </ul> </li> <li>- Optical Data Buses</li> <li>- Air Data, Gyro (Optical)                                     <ul style="list-style-type: none"> <li>• FADEC</li> <li>• Fault Tolerant</li> </ul> </li> <li>- Sensor Data Collection Network</li> <li>- Centralized vs. Distributed and How Much                                     <ul style="list-style-type: none"> <li>• HIRF, Cert Lab and flight</li> </ul> </li> </ul> </li> </ul>	<ul style="list-style-type: none"> <li>- Passive                             <ul style="list-style-type: none"> <li>• Avionics</li> <li>• Cabin Lighting</li> <li>• Landing Lights</li> <li>• Galleys</li> <li>• External Lighting</li> <li>• Anti Ice</li> </ul> </li> <li>- Active                             <ul style="list-style-type: none"> <li>• Pumps (fuel, etc.)</li> <li>• Environmental Control System</li> <li>• Actuators and Motors</li> <li>• Anti Ice (EIDA)</li> </ul> </li> </ul>

Table 3.5. Kinds of Testing Equipment for Ground Based Testing (Fly-By-Light)

- Models (generator, engine, aircraft, actuators)
- Real-Time computers/simulation
- Data collection and reduction
- Opto-electric test equipment (fiber optics)
- Basic test equipment (electronic)
- Fault insertion equipment (monitoring)
- Documentation tool
- EM/HIRF test equipment
- EME modeling and processing
- Environmental test equipment?
- Bus Timing
- Fixed base cockpit - pilot-in-the loop closure

Table 3.6. Kinds of Testing Equipment for Ground Based Testing (Power-By-Wire)

- Drive stands for generators
- Framework to lay out active loads (similar to ironbird)
- Copper Bird Lab (EME, loading aero-actuator)
  - Cooling (water)
  - Electrical power supply

Table 3.7. Aircraft Integration and Testing

- Aircraft and system monitoring
- Actuator installation
- Power management installation
- Engine starter/generator installation
- Flight control installation into nose of aircraft
- Power conversion
- Fiber optic data busses and pilot optical controls
- Externals Auxiliary Power Unit (APU) for ground start
- Fiber optic data busses
- Pilot optical control

Table 3.8. Types of Ground Testing

- Operational Flight Architecture (OAF)
  - Integrated first vs. study architecture
- Component developer test
  - 500 duty cycle hrs. loaded, temp., environment
  - Accelerated life testing
  - Fault/failure injection
- Integrated Testing
  - System-level testing
  - Copper-bird testing - all components
    - Fault tolerance, EME, maintainability, functionality
  - System timing
  - Model verification
    - Hardware, EME, System

Table 3.9. Types of Aircraft Testing

- Ground
  - System functionality, includes installation
  - System interface EME
  - Flight check systems
  - Model correlation
  - Maintainability and supportability
- Flight
  - System functionality
  - Limited flying qualifications checkout
  - EME check at altitude - internal EME, exercise landing gear
  - Corona discharge
  
- The characteristics of test facilities
- Issues to discuss with other technology sessions
- The need to demonstrate a flight-critical function and whether it should be tested in flight
- The need to flight test a representative EESG
- The need to test FBL/PBW in the propulsion system
- The need for a requirements and architecture synthesis study

### 3.5.3. SID Findings

SID recommends test facilities which will support research, laboratory ground testing (AIRLAB), and aircraft testing both on ground and in flight (ATOPS). The roles for these facilities are given in Table 3.11. A research or concept architecture which is flexible to allow insertion of new/alternate technology while producing credible results and enabling incremental technology transfer is recommended by SID. This architecture should be open and should support evaluation of FBL, PBW and hybrid technologies.

Table 3.10. Ground Integration Testing Facilities

- Models
  - Generator
  - Engine
  - Aircraft
  - Actuators
  - Operating
- Real-Time Computers/SIM
- Data Collection and Reduction
- Opto-Elec. Test Equipment (Fiber Optics)
- Basic Test Equipment (Electronics)
- Fault Insertion Equipment
- Documentation
- EM/HIRF Test Equipment
- EME Modeling and Processing
- Environmental Test Equipment?
- Bus Timing
- Fixed Base Cockpit - Pilot-in-the Loop Closure
- Drive Stands
- Copper Bird Lab (EME, Loading Aero Actuator)

Table 3.11. Attributes of Integration and Evaluation Architectures

	Ground	Aircraft
Concept Architecture	AIRLAB Architecture	ATOPS Architecture
Overall System Distributed Fault Tolerant	Substantial-All Key Technologies Integration, and Testing	Limited-Correlation of Ground to Aircraft Installations
	Operational Test R, M&S, EME	

In an effort to identify potential program cost savings and enable timely technology transfer, the SID panel recommends that NASA identify and evaluate existing ground and flight test beds which can be used to support NASA test facilities. Test beds for subsystem and/or integrated system tests should be considered.

Design criteria for the integration and test architectures should be established and prioritized. Competing architectural candidates should be analyzed and compared. Preferred architectures for concept, ground, and flight should be defined and design requirements should be established. To successfully define these test architectures, requirements for cost-effective FBL/PBW avionics architecture for a commercial transport must be established to serve as a basis for test architecture definition. The SID panel recommends that:

- Testing for components take place at the component suppliers facility
- Testing for subsystems take place at airframer, major subcontractor, and government facilities
- System and integration testing take place at NASA facilities
- Reliability testing take place at all locations

Tables 3.12 and 3.13 identify the FBL/PBW technology items or system attributes that must be demonstrated or evaluated using FBL/PBW test facilities. These items are from the perspective of SID panelists. Since many of these items are related to other technology areas, it is recommended that these demonstration items be reviewed

Table 3.12. Aircraft Testing and Evaluation

What We Absolutely Must Do	What Needs to be Done
Actively controlled optical fan speed sensor	Representative capacity power generator (engine mounted)
End-to-end fiber optic control	
Demonstrate regenerative power accommodation	Representative Fault Tolerant PMAD
Demonstrate installation and maintenance concepts	
Demonstrate power switching accommodation	
Aircraft EME internal model correlation and validation	
Representative optically controlled power switching	
Operational Transparency	
Representative Engine starter / generator	



Table 3.13. Ground Testing and Evaluation

What We Absolutely Must Do	What Needs to be Done
Thermal management	Power on Demand Capability
Certificability	Flight Critical Demonstration?
RM&S	Extend and Integrate FBL into other critical systems
Actuator/control	Production Manufacturer
Integration (end-to-end closed loop)	RM&S
Degraded operations	
Fault tolerance	
Flight-critical validation of controls and power	
EME/HIRF modeling/testing	
Validate experimental data and analysis system/approach correlation of ground and flight system and test/data gatherings	
Critical actuation	
Representative Engine Starter/Generator	

and revised, if necessary, by specialists representing other technology areas and by individuals with perspectives on certification and technology transfer.

It is recommended that FBL/PBW technology be demonstrated in-flight for the propulsion system. Questions regarding the in-flight engine environment (temperature, fuel, vibration, etc.) and FBL components need to be answered. As a minimum, the panel recommends that at least one optical sensor used in a closed loop control system be flight tested. For credibility, other panels may conclude that more extensive FBL technology must be demonstrated in an in-flight propulsion system. More extensive requirements could significantly impact the costs associated with modifying LaRC ATOPS 737. The issue of flight testing a flight-critical function was discussed. The flight rules for the LaRC ATOPS 737 do not permit this. Some believe that in-flight testing will be required to establish the credibility needed for technology acceptance. The impact of such a requirement would be substantial. Consensus on the necessity for flight testing a flight-critical function was not reached by the SID panel. However, it is recommended that a flight-critical function be validated in the ground demonstrations.

The issue of flight testing a representative (large enough to handle projected PBW requirements) EES/G was considered. Some panelists felt it would be essential for technology acceptance and certification. Moreover, Jim Treacy of the FAA expressed concern over an integral EES/G with regard to certification. In-flight demonstration

costs were of concern to other panel members. The prospect of extensive engine modifications, new engines, or a new LaRC ATOPS 737 aircraft to accommodate this requirement was considered too costly. Accordingly, in-flight EES/G demonstration is listed in both the must do and should do categories. This item must also be considered not fully resolved.

The issue of leveraging the results of non-NASA FBL or PBW programs to benefit NASA's program came up in discussions frequently. The FOCSI program is an example where leveraging is occurring. However, it was noted that testing to satisfy commercial transport ( $10^{-9}$ ) versus military aircraft ( $10^{-7}$ ) dictated additional FBL-related testing. As discussed above, it is recommended that other related non-NASA programs be identified and considered to support more rapid technology transition and reduced demonstration costs.

The issue of demonstrating FBL and PBW separately was brought up several times during the workshop. It was noted by some that FBL combined with PBW was a synergistic combination. An example cited was that the EMI, due to PBW, could be offset by EMI immunity afforded by FBL which, in turn, may be necessary for certification. This remains an open issue.

Figure 3.14 is a timeline developed in the SID panel session and is based on each panelist's experience in development of flight systems. Based on this, it can be concluded that to fly a system in 1998 requires that major component technology must be available and frozen in 1994.

### **3.5.4. Summary of SID Findings**

Requirements Recommended by SID

- Research architecture (flexible/open)
- Distributed fault-tolerant architecture
- Test RMS and EME
- End-to-end test (closed loop)
- Critical actuation must be demonstrated
- Flight test FBL control in propulsion system
- Validate flight-critical control and power
- Operational transparency

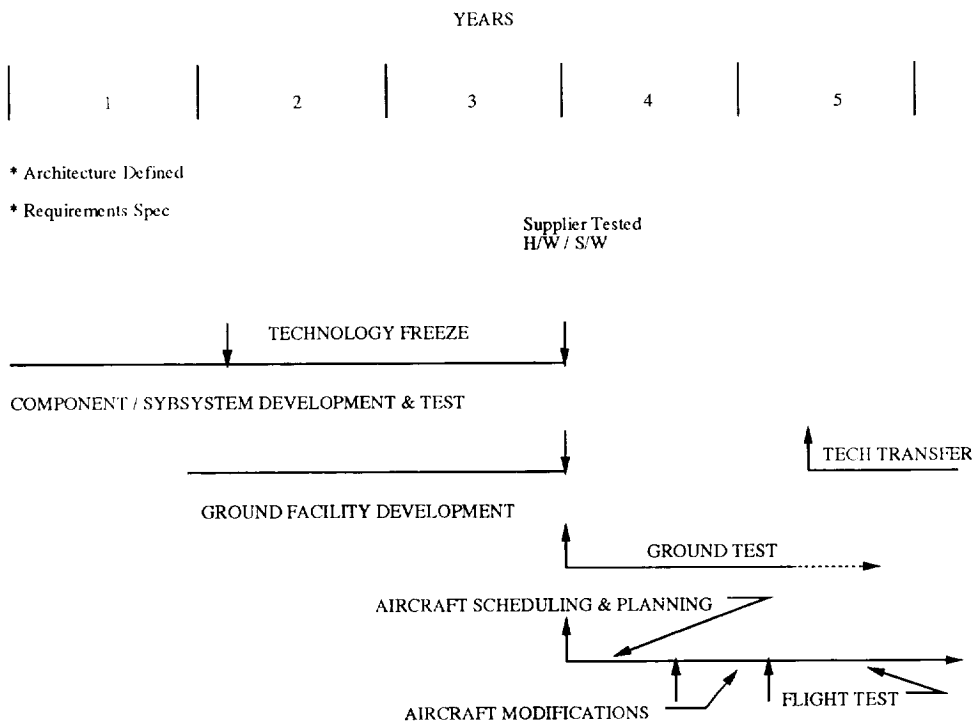

Figure 3.14. Development/Test Timeline

- Flight test EESG and fault-tolerant PMAD

#### Open Issues by SID

- Architecture
- Functionality
- Reliability, maintainability, supportability
- Manufacturability
- Human factors
- EME
- Thermal management
- Standards
- Interface standards

#### Recommendations by SID

- Study to prioritize design criteria, trade competing architectures, select architecture for ground and flight tests, define design requirements such as interfaces, functionality and environment

#### Requirements Not Addressed by SID

- Specifications for full system
- Specifications for ground and flight test system subsets

Chairperson, John Todd, presented the SID final summary report at the workshop closing plenary session. Viewgraphs used for this presentation are contained in Appendix E.

**APPENDIX A: List of Workshop Attendees**

# ATTENDEE LIST

Fly-By-Light/Power-By-Wire  
Requirements and Technology Workshop  
March 17-19, 1992

H. J. E. Reid Conference Center  
NASA Langley Research Center  
Hampton, VA

Ingrid Agolia  
Research Triangle Institute  
P.O. Box 12194  
Research Triangle Park, NC 27709-2194

Kenneth L. Albin  
Computational Logic Inc.  
1717 West Sixth Street  
Suite 290  
Austin, TX 78703-4776

Jose F. Aldana  
North American Aircraft  
Rockwell International Corporation  
201 North Douglas Street  
P.O. Box 92098  
Los Angeles, CA 90009

R. E. (Ralph) Alden  
Lockheed Aeronautical Systems Co.  
Department 73-02  
Marietta, GA 30063-0680

Radun Arthur  
General Electric  
P.O. Box 8  
Schenectady, NY 12301

Donald L. Backstrom  
Westinghouse Electric Corporation  
Electrical Systems Division  
P.O. Box 989  
Lima, OH 45802

Robert L. Baker  
Research Triangle Institute  
P.O. Box 12194  
Research Triangle Park, NC 27709-2194

Franklin J. Banks  
Banks Engineering & Labs  
11404 Sorrento Valley Road  
Suite 114  
San Diego, CA 92121

Robert G. Bartle  
United Technologies  
Pratt and Whitney  
MS 121-05  
400 Main Street  
East Hartford, CT 06108

Jeff Bartlett  
Research Triangle Institute  
P.O. Box 12194  
Research Triangle Park, NC 27709-2194

Dennis F. Baseley  
United States Air Force  
ASD/ENACE  
Wright Patterson AFB, OH 45433-6503

Robert J. Baumbick  
NASA Lewis Research Center  
Mail Stop 77-1  
21000 Brook Park Road  
Cleveland, OH 44135

Mike Baylor  
WL/POOX  
Wright Patterson AFB, OH 45433-6563

Edward Beauchamp  
Allied-Signal Aerospace Company  
AIRResearch Los Angeles Division  
2525 West 190th Street  
P.O. Box 2960  
Torrance, CA 90509-2960

Celeste M. Belcastro  
NASA Langley Research Center  
Mail Stop 130  
Hampton, VA 23665-5225

Brij B. Bhargava  
Ashman Consulting Services  
P.O. Box 3189  
Santa Barbara, CA 93130-3189

Ralph F. Bielinski  
Eaton Corporation  
Corporate Research & Development  
4201 N. 27th St.  
Milwaukee, WI 53216

Victor J. Bird  
Allison Gas Turbine Division  
Fiber Optic Technology  
Speed Code W-2A  
P.O. Box 420  
Indianapolis, IN 46206-0420

Paul E. Bjork  
Honeywell, Inc.  
Advanced Sensor Technologies  
3660 Technology Drive  
MN65-2600  
Minneapolis, MN 55418

Joseph A. Bluish  
Allied Signal Aerospace Co.  
Bendix Engine Controls Div.  
717 North Bendix Drive  
South Bend, IN 46620

Graham Bradbury  
Sundstrand Corporation  
4747 Harrison Ave.  
ATG 469  
P.O. Box 7002  
Rockford, IL 61125-7002

Al Burckle  
Naval Surface Warfare Center  
Crane Division  
Bldg. 2035, Code 6022  
Crane, IN 47522-5060

Linda Burrows  
NASA Lewis Research Center  
Mail Stop 301-2  
21000 Brook Park Road  
Cleveland, OH 44135

Steven P. Buska  
Honeywell, Inc.  
Systems and Research  
MS: MN09-A100  
10701 Lyndale Ave. S.  
Bloomington, MN 55420

Ricky W. Butler  
NASA Langley Research Center  
Mail Stop 130  
Hampton, VA 23665-5225

William T. Campbell  
Hughes Aircraft Company  
Bldg. 700, MS A2202  
P.O. Box H  
500 Superior Ave.  
Newport Beach, CA 92658-8903

Robert Carman  
Rockwell International Corporation  
Rocketdyne Division  
6633 Canoga Ave.  
Canoga Park, CA 91303

Ted E. Carr  
Honeywell, Inc.  
921 Holloway Street  
P.O. Box 2211  
Durham, NC 27702

Kiyong Chung  
GE Aircraft Engines  
One Neumann Way  
MD A320  
Cincinnati, OH 45215-6301

James S. Cloyd (Steve)  
WL/POOC-2  
Wright Patterson AFB, OH 45433-6563

Jerry Cohen  
Boeing Aerospace & Electronics  
MS 7J24  
P.O. Box 24346  
Seattle, WA 98124-24346

Tony Coleman  
Sverdrup Technology, Inc.  
LeRC Group  
2001 Aerospace Parkway  
Brook Park, OH 44142

J. F. Creedon  
NASA Langley Research Center  
Mail Stop 113  
Hampton, VA 23665-5225

Richard A. Crocco  
GE Aerospace  
Aircraft Control Systems Dept.  
P.O. Box 5000  
Binghamton, NY 13902

Aubrey E. Cross  
Research Triangle Institute/Virginia Office  
525 Butler Farm Road  
Suite 108  
Hampton, VA 23666

Mark A. Davis  
Moog, Inc.  
Missile Systems Division  
East Aurora, NY 14052-0018

Ben DiVito  
NASA Langley Research Center  
Mail Stop 130  
Hampton, VA 23665-5225

Kevin R. Driscoll  
Honeywell, Inc.  
MN65-2500  
3660 Technology Drive  
Minneapolis, MN 55418

Janet Dunham  
Research Triangle Institute  
P.O. Box 12194  
Research Triangle Park, NC 27709-2194

Carl R. Elks  
NASA Langley Research Center  
Mail Stop 130  
Hampton, VA 23665-5225

Stephen M. Emo  
Allied-Signal Aerospace Co.  
Bendix Engine Controls Division  
717 North Bendix Drive  
South Bend, IN 46620

Louis J. Feiner  
Douglas Aircraft Company  
Mail Code 18-61  
3855 Lakewood Blvd.  
Long Beach, CA 90846

Timothy Felisky  
Rockwell International Corporation  
Autonetics Marine Systems Division  
3370 Miraloma Ave.  
P.O. Box 4921  
Anahelm, CA 92803-4921

Luis Figueroa  
Boeing Defense and Space Group  
P.O. Box 3999, MS 7J-05  
Seattle, WA 98124-2499

George Finelli  
NASA Langley Research Center  
Mail Stop 130  
Hampton, VA 23665-5225

Richard T. Fingers  
WL/POOX  
Wright-Patterson AFB, OH 45433-6563

Dick Fletcher  
GE Aircraft Engines  
MD 340M2  
1000 Western Ave.  
Lynn, MA 01910

Ron Frazzini  
Honeywell, Inc.  
Systems & Research Center  
MN65-2500  
3660 Technology Drive  
Minneapolis, MN 55418

Gerry Fuller  
CK Consultants, Inc.  
5473A Clouds Rest  
Mariposa, CA 95338

Dagfinn Gangsaas  
Boeing Defense and Space Group  
Mail Stop 4C-70  
P.O. Box 3707  
Seattle, WA 98124-2207

Scott Gerber  
Sverdrup Technology  
NASA-LeRC  
MS 301-3  
21000 Brookpark Road  
Cleveland, OH 44135

Drew Glista  
Naval Air Systems Command  
Code Air 546TE  
Washington, DC 20361

Michael S. Glynn  
FAA Technical Center  
ACD 230  
Atlantic City Airport, NJ 08405

Robert C. Gunness  
Allied-Signal Aerospace Co.  
2525 West 190th Street  
Torrance, CA 90504-6099

Brian G. Hager  
WL/POOS-3  
Wright Patterson AFB, OH 45433-6563

Gordon L. Hamilton  
Douglas Aircraft Company  
Mail Code 36-48  
3855 Lakewood Blvd.  
Long Beach, CA 90846

Irving G. Hansen  
NASA Lewis Research Center  
Mail Stop 301-3  
21000 Brookpark Road  
Cleveland, OH 44135

Michael O. Hatfield  
Naval Surface Warfare Center  
Dept. H-22  
Dahlgren, VA 22448

Fredrick N. Heather  
Naval Air Warfare Center/Aircraft Division  
(SY-80EE)  
Patuxent River, MD 20670

Richard F. Hess  
Honeywell, Inc.  
Sperry Commercial Ft. Sys. Group  
Box 21111  
Phoenix, AZ 85036

David C. E. Holmes  
NASA Langley Research Center  
Mail Stop 256  
Hampton, VA 23665-5225

H. Milton Holt  
NASA Langley Research Center  
Mail Stop 469  
Hampton, VA 23665-5225

William Jackson  
Martin Marietta  
MS T330  
Denver, CO 80201

Thomas M. Jahns  
GE Corporate Research & Development  
Bldg. EP, Rm. 101  
P.O. Box 8  
Schenectady, NY 12301

Bruno Jambor  
Martin Marietta Astronautics Group  
MS T320  
Denver, CO 80201



Barbara Kenny  
NASA Lewis Research Center  
MS 301-2  
21000 Brookpark Road  
Cleveland, OH 44135

John M. Kilkenny  
Allied-Signal Aerospace Co.  
1321 Jamestown Road, Suite 104  
Williamsburg, VA 23185

William Kroll  
Sundstrand Corporation  
4747 Harrison Ave.  
P.O. Box 7002  
Rockford, IL 61125-7002

Jaynarayan Lala  
Charles Stark Draper Laboratory, Inc.  
555 Technology Square  
Cambridge, MA 02139

Wayne E. Lance  
Honeywell, Inc.  
Space & Strategic Systems Operation  
13350 U.S. Highway 19 North  
Clearwater, FL 34624-7290

Gail Loveland  
Research Triangle Institute  
P.O. Box 12194  
Research Triangle Park, NC 27709-2194

John K. Lytle  
NASA Lewis Research Center  
AAC-1  
21000 Brookpark Road  
Cleveland, OH 44135

Ed Mangelsen  
Martin Marietta Denver Aerospace  
P.O. Box 179  
Denver, CO 80201

Donald L. Martin  
The Boeing Co.  
MS 4C-70  
P.O. Box 3707  
Seattle, WA 98126

Kenneth G. Martin  
Rockwell International Corporation  
Collins Commercial Avionics  
400 Collins Road NE  
Cedar Rapids, IA 52498

Chris Mayer  
Ametek Aerospace Products  
Mail Stop 40  
50 Fordham Road  
Wilmington, MA 01887

Lisa C. McDonald  
McDonnell Aircraft Co.  
McDonnell Douglas Corp.  
Mail Code 0341240  
P.O. Box 516  
St. Louis, MO 63166

Kevin McGinley  
Naval Air Warfare Center  
Code 6012  
Warminster, PA 18974

John McGough  
Bendix Flight Systems  
Mail Stop 1-45A  
Teterboro, NJ 07608

David M. McLin  
Research Triangle Institute  
P.O. Box 12194  
Research Triangle Park, NC 27709-2194

Charles W. Meissner, Jr.  
NASA Langley Research Center  
Mail Stop 130  
Hampton, VA 23665-5225

Quin G. Mendoza  
Boeing Defense and Space Group  
MS 9F-01  
P.O. Box 3999  
Seattle, WA 98124-2499

Jim Mildice  
General Dynamics  
Space Systems Division  
MZ DC-8740  
P.O. Box 85990  
San Diego, CA 92186-5990

Michael B. Miller  
Litton Poly-Scientific  
Fiber Optic Products  
1213 N. Main Street  
Blacksburg, VA 24060-3100

Ronald J. Miller  
GE Aerospace  
Aircraft Control Systems Dept.  
P.O. Box 5000  
Binghamton, NY 13902

Charles E. Mitchell (Ed)  
Douglas Aircraft Co.  
Mail Station 18-61  
3855 Lakewood Blvd.  
Long Beach, CA 90846

R. Jorge Montoya  
Research Triangle Institute  
P.O. Box 12194  
Research Triangle Park, NC 27709-2194

ERIC MOON  
Allied-Signal Aerospace Co.  
Dept. 93-171  
M/Z 1303-206  
2739 E. Washington St.  
Phoenix, AZ 85034

Bruno Moras  
Boeing Canada  
de Havilland Division  
Garratt Boulevard, MS N45-05  
Downsview, Ontario  
Canada M3K 1Y5

Randall E. Morton  
ELDEC Corporation  
16620 13th Avenue West  
P.O. Box 100  
Lynnwood, WA 98046-0100

A. Ramayya Mulukutla  
GE Aircraft Engines  
1000 Western Ave.  
MD 170MW  
Lynn, MA 01910

William E. Murray  
Douglas Aircraft Co.  
Mail Code 18-61  
3855 Lakewood Blvd.  
Long Beach, CA 90846

William J. Myers  
GE Aircraft Engines  
One Neumann Way  
MD A320  
Cincinnati, OH 45215-6301

T. Peter Neal  
Moog, Inc.  
Aircraft Controls Division  
East Aurora, NY 14052-0018

Leon A. Newman  
United Technologies Research Center  
MS 129-92  
East Hartford, CT 06108

Peter A. Padilla  
NASA Langley Research Center  
Mail Stop 130  
Hampton, VA 23665-5225

Daniel L. Palumbo  
NASA Langley Research Center  
Mail Stop 130  
Hampton, VA 23665-5225

Anami S. Patel  
GE Aircraft Engines  
One Neumann Way  
MD A328  
Cincinnati, OH 45215-6301

James D. Patterson  
NASA Langley Research Center  
Mail Stop 130  
Hampton, VA 23665-5225

Steven T. Pennock  
Lawrence Livermore National Laboratory  
P.O. Box 808, L-156  
Livermore, CA 94551

Rodney A. Perala  
EMA  
12567 West Cedar Drive, Suite 250  
Lakewood, CO 80228-2091

Felix L. Pitts  
NASA Langley Research Center  
Mail Stop 130  
Hampton, VA 23665-5225

Andrew J. Poggio  
Lawrence Livermore National Laboratory  
University of California  
P.O. Box 808, L-156  
Livermore, CA 94550

John N. Polky  
Boeing Aerospace and Electronics  
P.O. Box 3999, MS 7J-27  
Seattle, WA 98124-2499

Gary Poppel  
General Electric Co.  
Mail Drop A320  
1 Neumann Way  
Cincinnati, OH 45215

Charles R. Porter  
Boeing Defense and Space Group  
P.O. Box 3999, MS 7J-05  
Seattle, WA 98124-2499

Stanley Pruett  
WL/FIGL-1  
Wright Patterson AFB, OH 45433

Richard E. Quigley, Jr.  
WL/POOX  
Wright Patterson AFB, OH 45433

Arthur Radun  
General Electric Corp.  
Research and Development  
Rm. K1-EP108  
P.O. Box 8  
Schenectady, NY 12301

Bob Rakoski  
Systems Engineering Test Directorate  
(SY-60)  
Naval Air Test Center  
Patuxent River, MD 20670-5304

Irving R. Reese  
Boeing Commercial Airplane Group  
P.O. Box 3707, MS 97-33  
Seattle, WA 98124-2207

David D. Renz  
NASA Lewis Research Center  
Mail Stop 301-2  
21000 Brook Park Road  
Cleveland, OH 44135

John N. Rice  
Sundstrand Advance Technology Group  
4747 Harrison Ave.  
P.O. Box 7002  
Rockford, IL 61125-7002

Eike Richter  
GE Aircraft Engines  
One Neumann Way, MD A320  
Cincinnati, OH 45215-6301

Mike Rietz  
1655 Timber Ridge Est. Drive  
Ellisville, MO 63011

Mary Ellen Roth  
NASA Lewis Research Center  
Mail Stop 301-2  
21000 Brook Park Road  
Cleveland, OH 44135

Richard A. Rudey  
Sundstrand Electric Power Systems  
4747 Harrison Ave.  
P.O. Box 7002  
Rockford, IL 61125-7002

John Rushby  
SRI International  
Computer Science Lab.  
333 Ravenswood Ave.  
Menlo Park, CA 94025

Peter J. Saraceni, Jr.  
FAA Technical Center  
ACD-230, Bldg. 201  
Atlantic City Int'l Airport, NJ 08405

Theodore J. Scarpino  
General Electric Co.  
MD 280  
P.O. Box 5000  
Binghamton, NY 13902

W. Scott Schaefer  
Moog, Inc.  
Technology Center  
East Aurora, NY 14052-0018

Charlotte O. Scheper  
Research Triangle Institute  
P.O. Box 12194  
Research Triangle Park, NC 27709-2194

Herb Schlickemaler  
NASA Headquarters  
Mail Code RJS  
600 Independence Ave. SW  
Washington, DC 20546

Henry A. Schmidt  
Moog, Inc.  
Aircraft Controls Division  
East Aurora, NY 14052-0018

Joseph M. Schwind  
Air Line Pilots Association, Int'l  
535 Herndon Parkway  
P.O. Box 1169  
Herndon, VA 22070

Daniel W. Seal  
McDonnell Douglas  
McDonnell Aircraft Company  
P.O. Box 516  
St. Louis, MO 63166-0516

David Segner  
Aviation Applied Tech. Directorate  
BD 401  
Ft. Eustis, VA 23602-5577

Gary T. Seng  
NASA Lewis Research Center  
Mail Stop 77-1  
21000 Brook Park Road  
Cleveland, OH 44135

Clarence W. Severt  
WL/POOC-1  
Wright Patterson AFB, OH 45433-6563

Naren M. Shah  
Northrop Corporation  
Aircraft Division  
One Northrop Ave., 3832/62  
Hawthorne, CA 90250-3277

Peter Shaw  
Northrop Corporation  
B2 Division  
Flight Sciences Technology T220/AP  
8900 E. Washington Blvd.  
Pico Rivera, CA 90660

Kang G. Shin  
University of Michigan  
Dept. of Elect Eng & Comp Science  
1301 Beal Avenue  
Ann Arbor, MI 48109-2122

W. Glen Smith  
Sundstrand Aerospace Corporation  
4747 Harrison Ave.  
P.O. Box 7002  
Rockford, IL 61125-7002

Gil Snow  
GE Aircraft Engines  
Tower Box 52  
2101 Executive Drive  
Hampton, VA 23666

Cary R. Spitzer  
NASA Langley Research Center  
Mail Stop 265  
Hampton, VA 23665-5225

C. Ed. Stevens  
Parker Hannifin Corporation  
Parker Berteau Aerospace  
14300 Alton Parkway  
Irvine, CA 92718-1814

John D. Stilwell  
Sundstrand Aviation  
Dept. 430-A6  
4747 Harrison Ave.  
Rockford, IL 61125-7002

Gale R. Sundberg  
NASA Lewis Research Center  
Mail Stop 301-2  
21000 Brook Park Road  
Cleveland, OH 44135

Joseph A. Tecza  
Mechanical Technology, Inc.  
Engineering and Technology Division  
968 Albany-Shaker Road  
Latham, NY 12110

John R. Todd  
Douglas Aircraft Co.  
Mail Code 36-48  
3855 Lakewood Blvd.  
Long Beach, CA 90846

James J. Treacy  
Federal Aviation Administration  
ANM-103N  
1601 Lind Ave., S.W.  
Renton, WA 98055-4056

Arun K. Trikha  
Boeing Commercial Airplane Group  
MS 6U-HP  
P.O. Box 3707  
Seattle, WA 98124-2207

Thomas F. Trost  
Dept. of Electrical Engineering  
Texas Tech University  
Lubbock, TX 79409

Richard C. VanNocker  
GE Aerospace  
Aircraft Control Systems Dept.  
P.O. Box 5000  
Binghamton, NY 13902

Lawrence C. Walko  
WL/POOX-3  
Wright Patterson AFB, OH 45433

Chris J. Walter  
Allied-Signal Aerospace Co.  
9140 Old Annapolis Road  
MD 108  
Columbia, MD 21045-1998

Oleg Wasynczuk  
Purdue University  
School of EE  
West Lafayette, IN 47907

Calvin Watson, Jr.  
The Boeing Company  
MS GR-UK  
P.O. Box 3707  
Seattle, WA 98124

Allan L. White  
NASA Langley Research Center  
Mail Stop 130  
Hampton, VA 23665-5225

David L. Whritenour  
GE Aerospace  
Aircraft Control Systems Dept.  
P.O. Box 5000  
Binghamton, NY 13902

Reuben A. Williams  
NASA Langley Research Center  
Mail Stop 130  
Hampton, VA 23665-5225

B. Edward Withers  
Research Triangle Institute  
P.O. Box 12194  
Research Triangle Park, NC 27709-2194

Robert Yeager  
WL/FIGL  
Wright Patterson AFB, OH 45433-6553

Keith A. Young  
Naval Air Warfare Center/AD  
Code 6012  
Warminster, PA 18974-5000

Steven D. Young  
NASA Langley Research Center  
Mail Stop 478  
Hampton, VA 23665-5225

Larry J. Yount  
Honeywell, Inc.  
MS: U35D5  
P.O. Box 21111  
Phoenix, AZ 85036

Richard Zacharias  
Lawrence Livermore National Lab.  
P.O. Box 808  
Livermore, CA 94551-9900

Klaus P. Zaeplfel  
NASA Langley Research Center  
Mail Stop 130  
Hampton, VA 23665-5225



## APPENDIX B: NASA FBL/PBW Program Plan

# PRELIMINARY

**NASA** Program Plan—

## Highly Reliable Fly-By-Light / Power-By-Wire Technology

February 1992

**NASA** Program Plan-  
Highly Reliable  
Fly-By-Light / Power-By-Wire  
Technology

February 1992

**Review**

APPROVED

APPROVED

\_\_\_\_\_  
Director for Flight Systems,  
Langley Research Center

\_\_\_\_\_  
Date

\_\_\_\_\_  
Director for Aeronautics,  
Lewis Research Center

\_\_\_\_\_  
Date

CONCURRED

\_\_\_\_\_  
Director, Subsonic  
Transportation Division,  
Code RJS

\_\_\_\_\_  
Date

APPROVED

\_\_\_\_\_  
Director for Aeronautics,  
Code RJ

\_\_\_\_\_  
Date

**NASA Program Plan–  
Highly Reliable  
Fly-By-Light / Power-By-Wire  
Technology**

February 1992

***Contents***

Purpose .....	1
Goal .....	1
Objectives .....	1
Authority .....	1
Background.....	1
Studies.....	1
The Economic Potential.....	2
Program Aims .....	3
Technology Transfer.....	4
Roles and Responsibilities.....	5
The Work Breakdown Structure.....	6
WBS 1.0, Integrated Requirements Definition and Preliminary Design .....	6
WBS 2.0, FBL Development and Test .....	6
WBS 3.0, PBW Development and Test.....	7
WBS 4.0, Fault Tolerant Architecture .....	8
WBS 5.0, EME Assessment Technology .....	8
WBS 6.0, Integration and Evaluation .....	9
Schedule.....	10
Procurement Plan.....	11
Resources.....	11
Budget.....	12



## Purpose

### Goal

The goal of the program is to develop the technology base for confident application of Integrated Fly-By-Light/Power-By-Wire (FBL/PBW) systems to transport aircraft.

### Objectives

1. Develop and flight test optical sensors and electro-optical converters;
2. Develop and ground test a power management and distribution system and flight test an electrical actuator;
3. Demonstrate architecture design and validation appropriate for certification of FBL/PBW systems;
4. Develop validated analytical and experimental assessment methodologies for electromagnetic environment effects;
5. Demonstrate end-to-end FBL/PBW systems in ground tests and partial flight test.

### Authority

This plan describes a program that is part of the NASA Aeronautics strategic thrust in *Subsonic Aircraft/National Airspace* (Thrust 1) to "develop selected, high-leverage technologies and explore new means to ensure the competitiveness of U. S. subsonic aircraft and to enhance to safety and productivity of the national aviation system." Specifically, this program is an initiative under Thrust 1, Key Objective 2, to "develop, in cooperation with U. S. industry, selected high-payoff technologies that can enable significant improvements in aircraft efficiency and cost." This plan addresses technical issues associated with the potential economic benefit to the U. S. manufacturers of FBL/PBW technology.

## Background

### Studies

The potential commercial benefit to be derived from employing optical and electro-optical technology (Fly-By-Light-FBL) and electrical actuators (EA) in aircraft control systems, as well as the benefits derived from the use of an all-electric secondary power system (Power-By-Wire-PBW) are very high. The use of FBL technology in high performance aircraft is being evaluated by the NASA-Navy "Fiber Optic Control System Integration" (FOCSI) program<sup>1</sup> and favorable studies of FBL technology use in commercial transports have been completed by Douglas Aircraft for the propulsion system<sup>2</sup> and Boeing Commercial Airplanes and Douglas for the airframe<sup>3</sup>.

Studies by Lockheed<sup>4</sup> and NASA Lewis<sup>5</sup> indicated a significant commercial potential for PBW technology including the use of EA's. A study with McDonnell-

---

<sup>1</sup>- FOCSI, is an on-going NASA-Navy joint program to develop and demonstrate a fiber optic-based control system for advanced fighter aircraft.

<sup>2</sup>- NASA Lewis (1989) sponsored study of FBL for transport propulsion system with Douglas Aircraft.

<sup>3</sup>-NASA Langley (1991) sponsored study of FBL for airframe system with Boeing Commercial Airplanes and Douglas Aircraft.

<sup>4</sup>-NASA Langley-supported study with Lockheed, 1980. Comparisons of technology upgrades versus cost.

<sup>5</sup>-NASA Lewis study based on Boeing data, 1985. Power-by-wire technology, the LeRC All-Electric Power System Study.

Douglas is currently underway to ensure that the commercial benefits of PBW are still applicable to current and future generation aircraft<sup>6</sup>.

With an ongoing military interest in this technology, a significant NASA skill-pool exists to exploit the technology and transfer it to the commercial aviation industry.

### **The Economic Potential**

#### *The Fly-By-Light Contribution.*

The McDonnell Douglas Corporation with Honeywell Incorporated (1990) produced the "Fly-By-Light Technology Development Plan," under contract NAS1-18028, Task 9, with NASA. The purpose of the plan was to facilitate the introduction and certification of U. S.-built Fly-By-Wire (FBW)/Fly-By-Light commercial transport aircraft. The study was directed to two concerns, namely the loss of U. S. market share and safety.

The report described the benefit of FBL for a narrow-body and wide-body commercial transport aircraft. For example, a review of 163 aircraft systems showed that 72.4% of the systems were considered to have a "good-applicability" rating for conversion to fiber optics. Additionally, 16.6% had a "slim-applicability" rating and only 11.0% of the systems were not applicable to FBL technology. The results of the narrow-body flight control life cycle cost comparison (between the mechanical baseline and the FBL) showed a 10.0% reduction in the direct operating costs (D.O.C.) and a 20.0% improvement in the return on investment (R.O.I.). The comparison for the wide-body aircraft showed a 7.4% reduction in D.O.C. and a 10.2% improvement in R.O.I. The report is the foundation for quantifying the attractive economic potential of FBL technology.

The report noted that the only currently flying FBW aircraft is perceived to have a more technically advanced flight control technology than other comparable U.S.-built aircraft. The report also noted that the perceived barriers to the introduction of U.S. FBW or FBL aircraft is a lack of clear definition of the certification basis for aircraft manufactured in the U.S. It was noted that the certification of the current FBW aircraft was conducted by the nation-of-manufacture; the U.S. certification of that aircraft, therefore, was conducted under a reciprocal certification agreement. Accordingly, a risk to U.S. aircraft manufacturers is not *only* the technology challenge, but an equally demanding challenge of a clear definition of the basis and procedures for certification. This point portends a challenge for the NASA program to establish a robust means of technology transfer—not only direct technology transfer to the manufacturers—but also an appropriate transfer to the FAA of a body of technical documentation for its role as certifier.

#### *The Power-By-Wire Contribution.*

A Lockheed study, December 1980, compared five technology upgrades (super-critical wing, active controls, advanced engines, all electric secondary power, and advanced composites) versus cost (cents per seat mile using the cost of jet fuel of \$1.00 per gallon). The results on a 500 passenger transport showed that the advanced composites provided the most cost savings (25¢ per seat mile).

---

<sup>6</sup> -NASA Lewis-sponsored, started October 29, 1990, selected an advanced 200-passenger tri-engine commercial transport as the base aircraft.

followed closely by All Electric Secondary Power (19¢ per seat mile) and Advanced Engines (15¢ per seat mile).

A May 1985 NASA study based on Boeing-supplied data for a B-767 aircraft used high frequency (20 KHz) in the Advanced Secondary Power System. The results incorporating a down-sized airplane showed a weight and fuel saving of approximately 10%. This study included integral starter/ generators, electrical actuators and an environmental control system. Both the hydraulic and pneumatic systems were eliminated.

In 1990, Douglas Aircraft began a study for NASA to determine the cost benefits of a conventional-technology, all-electric aircraft compared to an airplane in today's fleet. Douglas' study used a 200 passenger, three-engine jet with a 400 Hz power management and control system with conventional hydraulic, pneumatic and air bleed systems to reflect today's technology. Early results from this study are showing weight and fuel savings in the 2-3% range for a re-sized aircraft. Furthermore, improvements in system reliability and maintainability are predicted which result in lower operational costs.

## Program Aims

The full benefits of full-authority digital computer control of transport aircraft have not yet been fully realized for U. S. aircraft. The intrinsic EMI immunity of optics technology embodied in Fly-By-Light can significantly enhance acceptance of full authority digital control by circumventing electromagnetic interference (EMI) concerns associated with Fly-By-Wire, and provide lifetime immunity to signal EMI. This benefit will become increasingly important as non-shielding composites are introduced in the aircraft construction process. Additionally, FBL has the potential to greatly simplify certification against EMI by enabling technically acceptable bench tests of subsystems, as opposed to full airplane systems tests which are required to account for the interaction of EM threats such as High Intensity Radiated Fields (HIRF) with wire based signal transmission media.

Power-By-Wire results in significant weight savings, simplifies maintenance through elimination of centralized hydraulics, provides for more efficient engine operation by eliminating the need for variable engine bleed air, and eliminates the need for the complex variable speed constant frequency drives of present generation secondary power systems.

The aim of the Fly-By-Light effort is to evaluate and test the *replacement* of electronic data transmission and electronic sensors with optical components and subsystems.

The aim of the Power-By-Wire effort is to evaluate and test the *elimination* of hydraulics, variable engine bleed air, and the constant speed drive for power generation through advances in aerospace power system technologies such as:

- Electronic motor controllers and electric motors,
- Power system distribution and control, and
- An integral starter/generator.

## Technology Transfer

One of the main reasons that U. S. aircraft manufacturers have not taken advantage of the benefits of FBL/PBW, is due to the uncertainty of the costs associated with the certification of the new technology. The benefits of reduced D.O.C. and improved R.O.I. are not sufficiently large enough to offset the risks associated with the U. S. manufacturers' ability to certify an aircraft with FBL/PBW technology. NASA will interact with the aviation industry through a Technical Advisory Group (TAG) to ensure the timely transfer of technology. In the process, NASA acts to reduce the industry's uncertainties by providing technically sound, engineering data to the U. S. manufacturing community.

In order to maintain and nurture the industry's involvement in this program, a series of workshops and meetings will be conducted throughout the program to solicit their insights in this research area. The initial requirements-definition workshop will solicit industry participation in the technology integration, and, as such, will provide the forum for the technical level exchange between the NASA research team and the industry. During the course of the program, a series of Program Review Workshops will be held to review results and to provide a mechanism for program assessment and critique. An advisory group will be assembled to participate in the workshops, assimilate and summarize workshop output, and provide inputs to NASA. In this way, the evolving technology application will have the highest assurance of transferring to the industry. The advisory group will be a smaller group composed of management representatives of U.S. manufacturers, FAA researchers and the NASA researchers. This group would meet regularly to: 1. review progress-to-date against objectives, 2. review resolution of technical issues, and 3. seek the advice and counsel of team members based on their areas of expertise to resolve non-research issues that may affect the conduct of the program.

NASA will join with the FAA's aviation safety research organization as a means of transferring the information within the FAA.

Further, NASA will work with the U.S. aircraft manufacturers, the avionics manufacturers, and the airlines to focus the requirements from the industry to the NASA research team.

Finally, NASA—for the purposes of advocating U.S. competitiveness—will ensure that technical documents describing details of the FBL/PBW elements will be marked "For Early Domestic Dissemination (FEDD)."

## Roles and Responsibilities

This is a joint NASA HQ, Langley, and Lewis Research Center program. Lewis Research Center objectives are to develop and flight test: optical sensors and electro-optical converters, a power management and distribution system with integral starter/ generator, and electrical actuators (WBS 2.0 and WBS 3.0). LaRC will lead the WBS 1.0 Integrated Requirements Definition and Preliminary Design activity and will ensure that technology from the LeRC WBS 2.0 and WBS 3.0 elements meshes with the reliability, validation, and certification needs implemented in the WBS 4.0 Fault Tolerant Architecture element. In performing this coordination, LaRC will work closely with LeRC and its contractors to infuse current reliability and validation technology and to establish

compatible protocols and sub-system interfaces. Flight test and evaluation (WBS 6.0) will be conducted at LaRC on the Transport Systems Research Vehicle under the auspices of the ATOPS. The FAA Engineering, Research, and Development Service at FAATC is a consulting member of the team to provide advice and counsel regarding U.S.-civil aircraft regulatory and certification issues and will span all of the WBS elements. This effort will act as the means to encourage the FAA National Resource Specialist and the appropriate Aircraft Certification Office(s) to monitor the FBL/PBW program early on, to be used to establish a certification basis and develop a certification plan.

Headquarters-Program management responsibilities:

Code RJS, Subsonic Transportation Division  
Herb Schlickemaier, FTS 453-3723, NASA Manager, Aeronautical Systems: responsible to Code RJS for program performance.

Centers-Technical points of contact:

LaRC

Chuck Meissner, LaRC Program Manager, FTS 928-6218  
Felix Pitts, LaRC FBL/PBW Technical Program Manager,  
FTS 928-6186  
Cary Spitzer, ATOPS Integration Manager, FTS 928-3854

LeRC

Gary Seng, LeRC Program Manager, FTS 297-3732  
Gale Sundberg, LeRC Deputy Program Manager, FTS 297-6152  
Bob Baumbick, LeRC FBL Technical Program Manager, FTS 297-3735  
Dave Renz, LeRC PBW Technical Program Manager, FTS 297-5321  
Pete Saraceni, FAATC<sup>7</sup> FTS 482-5577, coordinates certification-issues planning.

---

<sup>7</sup>Implemented through "Digital Systems Validation Technology Assessment" agreement with FAA (MOA/IAA number DTFA03-89-A-00005) at FAATC, ACD-200.

## The Work Breakdown Structure

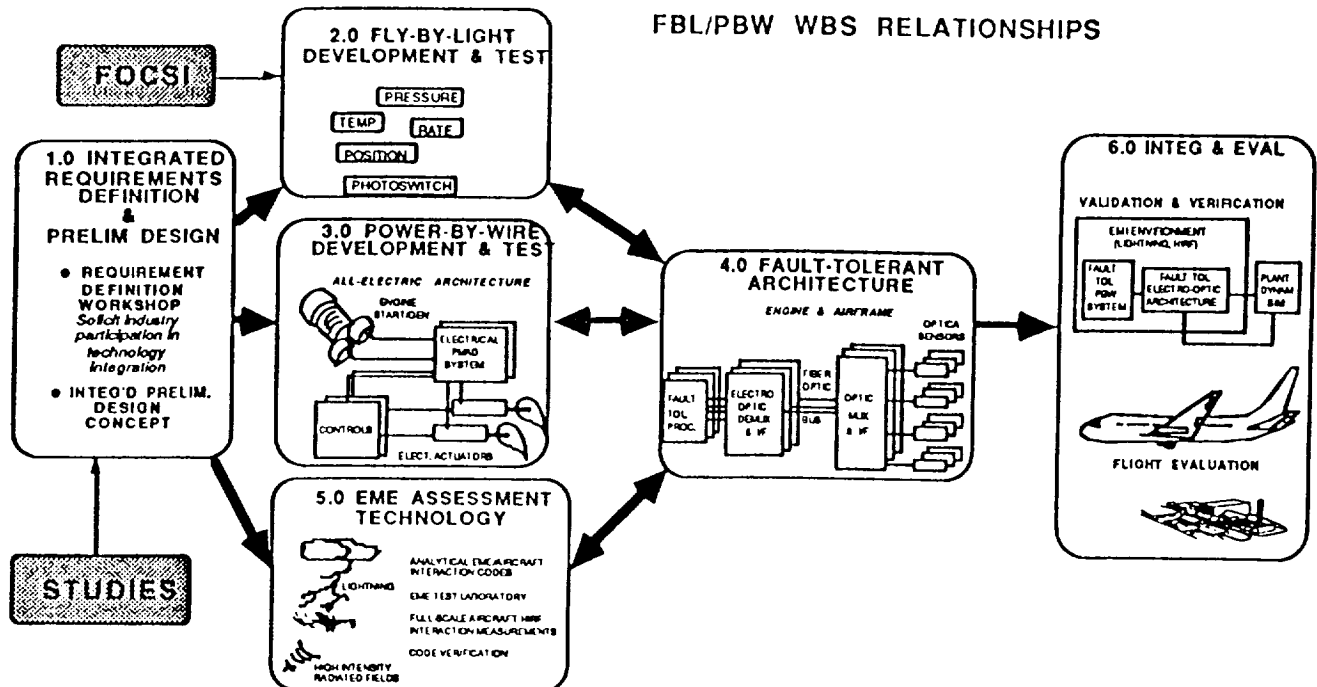

### WBS 1.0, Integrated Requirements Definition and Preliminary Design

The objective of this element is to assimilate earlier industry studies and research efforts into one comprehensive document set in order to establish the foundation from which to specifically proceed with this effort. A technical industry/ Government requirements-definition workshop will be organized to support this element as defined in the Technology Transfer section. This element acts as the kernel for elements WBS 2.0, 3.0, 4.0 and 5.0.

### WBS 2.0, FBL Development and Test

The objective of this element is to design, build and flight test passive optical and optically-powered (hereafter referred to as *optical sensor*) sensor systems for closed-loop control and condition monitoring of a commercial aircraft. The optical sensors will be located as close as possible to existing sensors to allow comparison of both types of sensors, as well as closed-loop operation; i.e., aircraft response with optical sensor systems active compared to active bill-of-material (BOM) sensor systems.

The approach to accomplish the objective of this work element is:

- (a) **Definition:** In this phase the following items will be addressed: specification of sensor requirements (i.e., range, accuracy, response, resolution, linearity, etc.), level of redundancy and built-in-test requirements, operational environment, installation specifications, and development of a test plan for component and system functional and environmental tests, including ground tests and flight tests for the optical sensor systems. The flight test plan shall identify what data will be required, how often data will be taken and in what final form data will be required.

(b) **Design:** In this phase the following items will be addressed: design of sensor architecture (including level of redundancy required and novel approaches of multiplexing sensor suites), design of electro-optic converter architecture (including level of redundancy required), and design of electro-optic interface to fault tolerant databus in the specified format.

(c) **Fabrication:** In this phase the following items will be addressed: purchase of- or fabrication of components (including optical sensors, optical fibers, connectors, electro-optical components), and the fabrication of three complete sensor systems for aircraft control. One system will be used for ground testing and trouble shooting of flight systems, one system will be installed on aircraft and one system will be held as a spare to replace those components of installed system that fail.

(d) **Assembly:** In this phase the following items will be addressed: assembly of sensor systems for ground testing (including functional and environmental testing) and testing same.

(e) **Installation:** In this phase the following will occur: optical fibers (primary line and spare line will be installed in the aircraft without connectors), connectors will be installed on fibers, and optical sensor systems will be installed on aircraft.

(f) **Testing:** In this phase ground testing of the complete optical sensor system will be performed and closed-loop flight tests with the complete optical sensor system (including any condition monitoring sensors) active will be conducted according to the test plans formulated above.

### **WBS 3.0, PBW Development and Test**

The objective of this element is to design, build and test a PBW system for a commercial aircraft. The PBW system consists of an integral starter/generator, a fault tolerant PMAD (Power Management and Distribution) system, system power processor and electrical actuator systems.

The approach to accomplish the objective of this work element is:

(a) **Definition:** In this phase, requirements for the fault tolerant PMAD system and the PBW components (starter/ generator, power processors, motor controllers and electrical actuators) will be determined. These requirements will include such parameters as: system and component efficiency, voltage regulation, EMI specification, reliability, interface requirements (power and control), and Built-In-Test and testing.

(b) **Design:** In this phase, the fault tolerant PMAD system, electrical actuator system, integral starter/ generator and PBW components will be designed to meet the requirements determined in (a).

(c) **Fabrication:** In this phase, multiple components will be fabricated to meet the requirements of the testing program plus spares, as required.

(d) **Testing:** In this phase, there will be component check out and testing at both LeRC and the contractors. There will be system testing at LeRC/

contractor and at LaRC. The integral starter/ generator will be tested at the contractor and at LeRC. A partial flight test of one electrical actuation system controlled by optic controls in a closed loop mode is also planned.

#### **WBS 4.0, Fault Tolerant Architecture**

The objective of this element is to devise, analyze, develop, fabricate, and test an optically based Fly-By-Light/Power-By-Wire architecture consisting of redundant optical sensors, fault tolerant fiber optic signalling, low maintenance, high availability, ultra-high reliability fault tolerant computers, and a secondary power management and distribution system appropriate for advanced transport aircraft.

The approach will be to determine system level requirements, synthesize an architecture meeting the requirements, and validate that the architecture meets the requirements by applying design for validation concepts throughout the design process. This will entail close coordination with LeRC personnel on the optical sensors and power-by-wire technology to be used in the architecture.

#### **WBS 5.0, EME Assessment Technology**

The objective of this element is to develop techniques and methodologies for assessing the effects of lightning electromagnetic transients and High Intensity Radiated Fields (HIRF) on digital electronics aboard advanced aircraft .

The advent and projected application of composite structures with flight critical digital electronics compound EMI problems in advanced aircraft since composite structures do not provide shielding equivalent to that of metal aircraft, and digital systems are potentially more susceptible to "upset" by electrical transients than previous analog electronic systems. The term upset refers to the propensity for digital electronic systems to malfunction as a result of electronic transients and is one of the most elusive and insidious problems caused by the electromagnetic environment affecting digital computers. Upset refers to functional error modes wherein the digital computer, although not permanently damaged, no longer performs its intended function until it is either reset or the memory is reloaded.

Digital computers employed in future transport aircraft will be critical to flight, and must reliably operate in harsh electromagnetic environments (EME) as caused by lightning strikes and HIRF. Tools and techniques must be developed to verify the integrity of digital computer based systems operating in these environments since upsets cannot be tolerated in advanced aircraft systems.

The approach to internal EME prediction will utilize the capability developed recently by the Lawrence Livermore Laboratory to assess the the survivability of military systems to the High Power Microwave Environment. The LLNL methodology addresses the "electrical" aspects of the upset problem, i.e., the prediction of induced voltages and currents. Higher level assessment must also address software functionality as will be done in the HIRF laboratory. The LLNL methodology has been successfully applied to a number of military systems. In this approach, the LLNL codes will be used to model EM interactions, and will be validated by comparing with canonical form results and by comparing with actual aircraft measurements. The LLNL EM modeling codes, called



Temporal Scattering and Response EM Modeling, or TSAR are based on the three dimensional linear finite difference solution to Maxwell's equation to provide the solution to the coupling problem. LLNL has augmented this method with pre and post processing to aid the utility of the code.

### **WBS 6.0, Integration and Evaluation**

The objectives of the integration and evaluation element is to integrate various FBL/PBW technologies and accomplish comprehensive laboratory evaluation and flight test of selected sub-systems. Clearly, much of the preparation and ground work for this element was laid in the FBL/PBW Architecture element through establishment of compatible protocols, interfaces, etc.

The approach is to coordinate a compatible overall architecture from the program elements by reviewing and coordinating various program work statements including: optical sensors, power-by wire actuators, secondary power management and distribution system, fault tolerant architecture, and electromagnetic assessment methodology from an overall systems viewpoint. Assimilate and integrate technologies developed in other program elements, configure a laboratory system and perform test and evaluation of a FBL/PBW system in AIRLAB. Select and perform flight evaluation of a sub-set of a representative FBL/PBW system on the LaRC Boeing 737 aircraft.

In the laboratory evaluation, a system consisting of actual (where possible) optical sensors, an optically based fault-tolerant processing and signalling system, and selected fault-tolerant electrical actuators, all operating from a partial Power Management and Distribution System will be evaluated while operating in a criterion EMI environment and processing application software controlling a simulated plant.

Ground testing and evaluation of a complete FBL/PBW architecture that meets all the requirements for commercial aircraft applications will not be feasible, due to the magnitude of the task. The multitude of components: sensors, actuators, computers, communication interfaces, power converters, power bus switching and wiring, etc. required to make the architecture suitable for its target application precludes, without extensive resources, complete ground implementation and testing. Common practice is to implement a proof-of-concept limited design with enough complexity to give the designers confidence that a sufficiently complete and reliable design has been achieved. Once the ground testing results have validated the designers' expectations, flight testing can proceed with high probability of success. This strategy will be used in the integration/evaluation element of the FBL/PBW program.

A subset of the architecture must be selected which is sufficiently complete and representative of the complete architecture such that the results of the evaluation tests can be meaningfully extrapolated to the complete system. The selection method for the actual architectural components to be incorporated in the ground test is not well defined by any procedure or standard implementation. As a minimum an evaluation must include those components which are, as a subset of the total architecture, a complete functioning entity capable of performing a fractional amount of the real workload to be performed by the complete implementation.

# Schedule

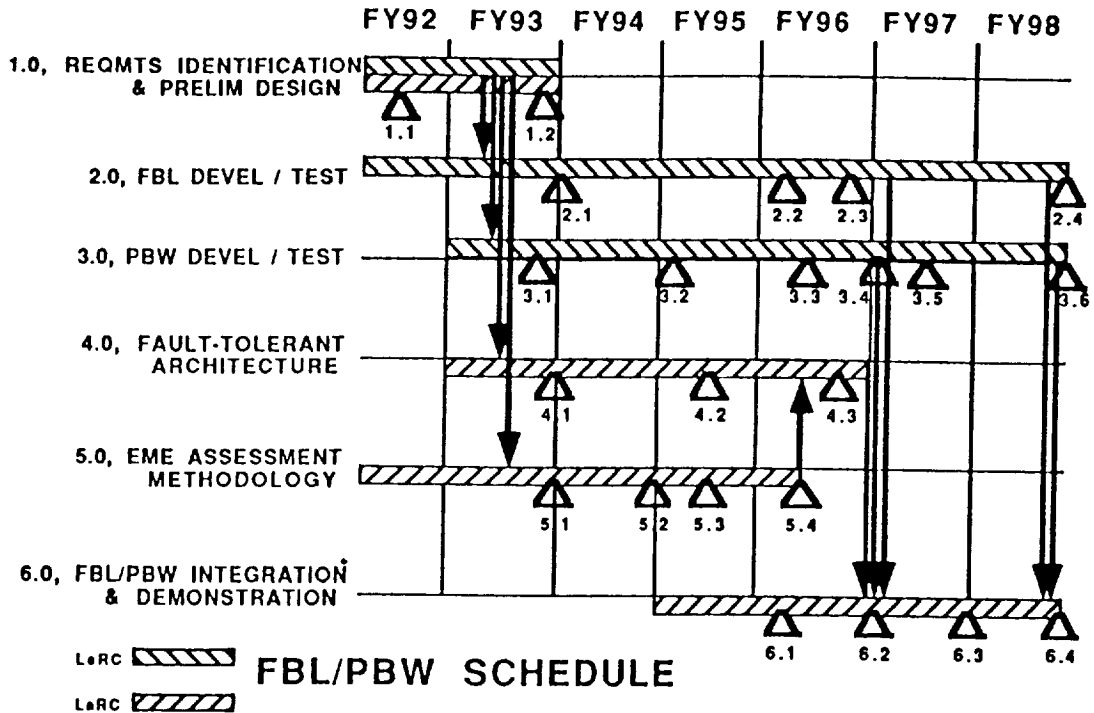

Milestone Number	Date	Description
1.1	FY92, 2Q	Requirements Definition Workshop
1.2	FY93, 3Q	Requirements/Preliminary Design Defined (requirements sent to LaRC/LeRC for #'s 2.1, 3.1, 4.1 and 5.1)
2.1	FY93, 4Q	FBL sensors Selected, Architectural Design
2.2	FY95, 4Q	<b>FBL Hardware Environmental Test</b>
2.3	FY96, 4Q	Engine Sensor Ground Test (Optical components sent to LaRC for Integration and Demo, #6.2)
2.4	FY98, 4Q	FBL closed-loop flight test completed
3.1	FY93, 3Q	Define Power Management and Distribution (PMAD) for Power By Wire system
3.2	FY95, 1Q	PMAD designed, and Electrical Actuator (EA) fabricated
3.3	FY96, 2Q	Test PMAD and fabricate generator
3.4	FY96, 4Q	End-to-end ground test (PBW system sent to LaRC for Integration and Demo, #6.2)
3.5	FY97, 3Q	Complete testing of engine/generator combination
3.6	FY98, 4Q	PBW closed-loop flight test completed
4.1	FY93, 4Q	Specify fault-tolerant architecture
4.2	FY95, 3Q	Laboratory fabrication
4.3	FY96, 3Q	<b>Reliability validation complete (Fault tolerant architecture ready for test, #6.2)</b>
5.1	FY93, 4Q	Select codes
5.2	FY94, 4Q	Laboratory complete
5.3	FY95, 3Q	Laboratory-verify codes
5.4	FY96, 2Q	Aircraft-verify codes (EME assessment methods are transferred to fault-tolerant architecture in time for #4.3)
6.1	FY96, 1Q	Integrate sensors, architecture and PMAD

6.2	FY97, 1Q	FBL/PBW end-to-end ground tests
6.3	FY97, 4Q	EME validation
6.4	FY98, 4Q	FBL/PBW flight test and evaluation of selected sub-systems

## Procurement Plan

All of the tasks can be handled through normal contracting procedures. Since the tasks have some attendant risk associated with their completion, all major contracts will be cost plus fixed fee. Task-assignment-type contracts will be used for reviews or studies. Multi-year contracts will be bid where appropriate to perform large-scale, identifiable tasks.

## Resources

The FBL/PBW program will require the participation of both civil service and contractor staff to meet the program objectives. With the roles and responsibilities outlined above, the following tables detail the planned staffing distribution between LaRC and LeRC.

## Total Staffing Requirements by Fiscal Year

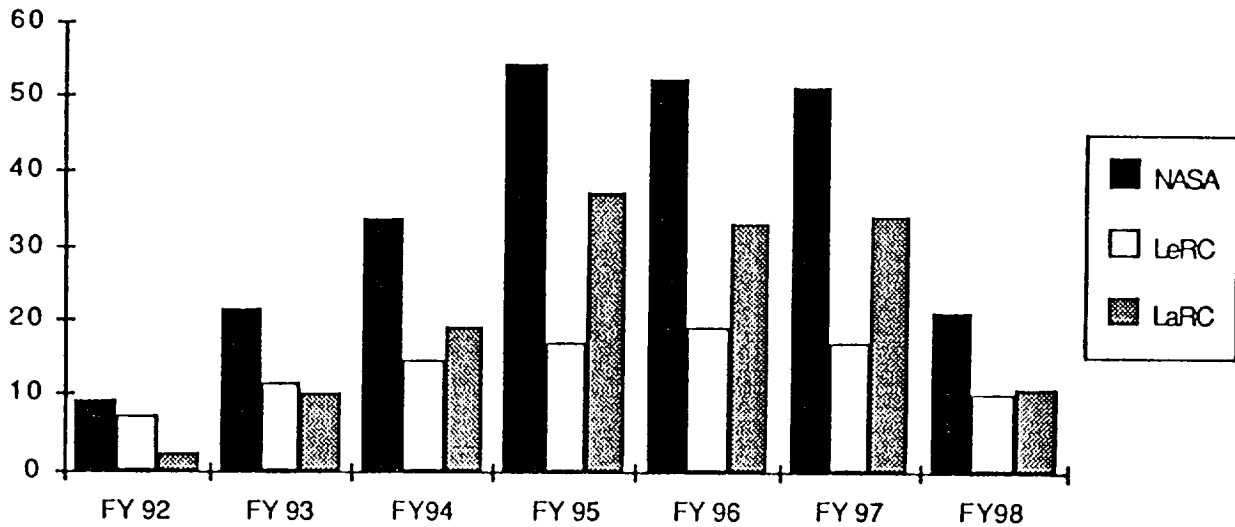

## Budget

The FBL/PBW program is a NASA Aeronautics Systems Technology program and is part of the Advanced Subsonic Technology (538) effort. The program tag is 538-01.

### Gross R&D Funds Distributed by WBS

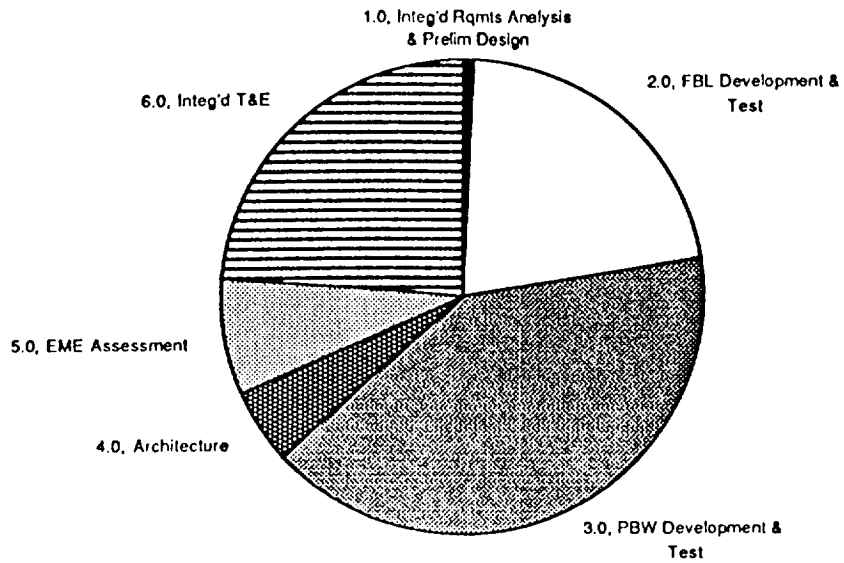

### Gross R&D Funds Distributed by Fiscal Year

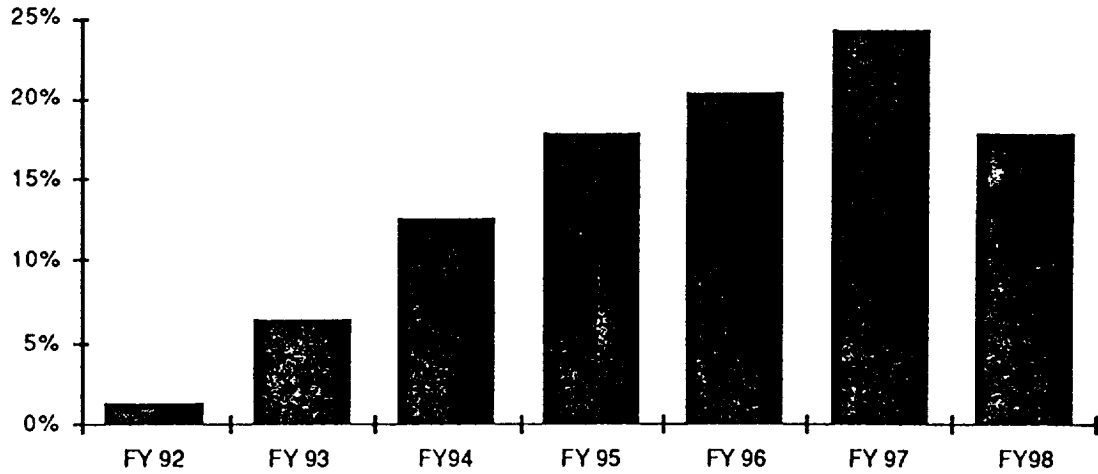

## APPENDIX C: Introductory Presentations

FBL/PBW Requirements and Technology Workshop Overview - Felix Pitts

PBW Systems Panel Sessions Technical Work Plan - Louis Feiner

Highly Reliable PBW Aircraft Technology Program Overview - Gale Sundberg

Electromagnetic Environment - Felix Pitts

**FBL/PBW Requirements and Technology Workshop Overview**  
**- Felix Pitts**



FLY-BY-LIGHT/  
POWER-BY-WIRE  
TECHNOLOGY

**FBL/PBW WORKSHOP**

# **FLY-BY-LIGHT/POWER-BY-WIRE REQUIREMENTS and TECHNOLOGY WORKSHOP**

**NASA** Langley Research Center

**March 17-19, 1992**



FLY-BY-LIGHT/  
POWER-BY-WIRE  
TECHNOLOGY

# OUTLINE

**PROGRAM OBJECTIVE**

**WORKSHOP OBJECTIVE**

**AGENDA**

**PANELS AND CHAIRPERSONS**

**WORKSHOP CHALLENGE**





## **HIGHLY RELIABLE FLY-BY-LIGHT/POWER-BY-WIRE SYSTEMS TECHNOLOGY**

**GOAL:** Develop the Technology Base for Confident Application of Integrated FBL/PBW Systems to Transport Aircraft

### **OBJECTIVES:**

- **Develop and Flight Test Optical Sensors and Electro-Optical Converters**
- **Develop and Ground Test a Power Management and Distribution System and Flight Test an Electrical Actuator**
- **Demonstrate Architecture Design and Validation Appropriate for Certification of FBL/PBW Systems**
- **Develop Validated Analytical and Experimental Assessment Methodologies for Electromagnetic Environment Effects**
- **Demonstrate End-to-End FBL/PBW Systems in Ground Tests and Partial Flight Test**

# FBL/PBW APPROACH



## FOCSI

### OPTICAL SENSOR DEVELOPMENT & EVALUATION

PRESSURE

TEMP.

RATE

POSITION

PHOTOSWITCH

### FAULT-TOLERANT ELECTRO-OPTIC ARCHITECTURE DESIGN & SENSOR INTEGRATION

ENGINE & AIRFRAME

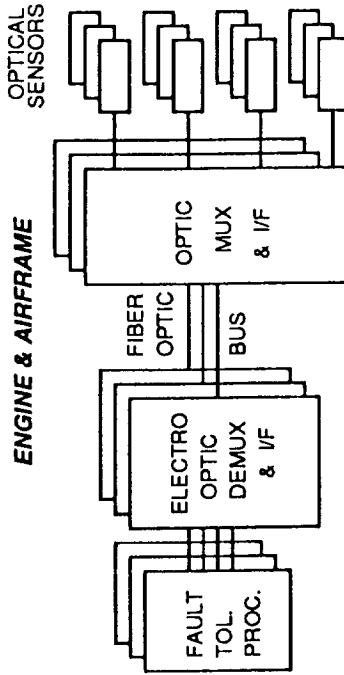

### INTEGRATED SYSTEM VALIDATION AND VERIFICATION

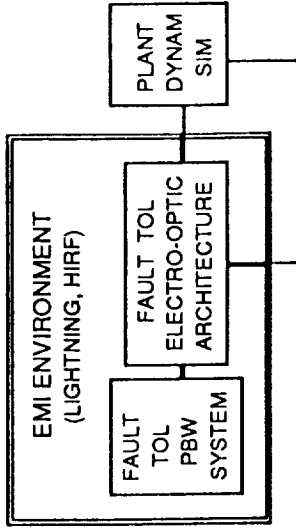

### FAULT TOLERANT POWER-BY-WIRE SYSTEM DEVELOPMENT

ALL-ELECTRIC ARCHITECTURE

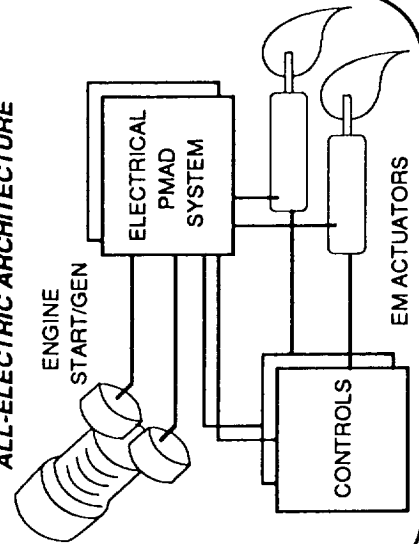

### COMPONENT FLIGHT EVALUATION

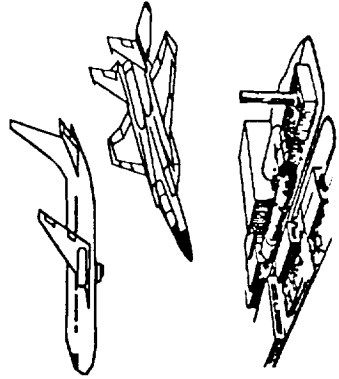

### ELECTROMAGNETIC ENVIRONMENT (EME) ASSESSMENT METHODOLOGY

ANALYTICAL EME/AIRCRAFT  
INTERACTION CODES

EME TEST LABORATORY

FULL-SCALE AIRCRAFT HIRF  
INTERACTION MEASUREMENTS

CODE VERIFICATION

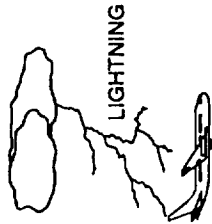

HIGH INTENSITY  
RADIATED FIELDS



FLY-BY-LIGHT/  
POWER-BY-WIRE  
TECHNOLOGY

# WORKSHOP OBJECTIVE

---

---

- DETERMINE TECHNICAL REQUIREMENTS
- ASSESS PLAN ADEQUACY
  - OBJECTIVES
  - TECHNOLOGY TRANSFER
- PREPARE TECHNICAL REPORT 6/92





FLY-BY-LIGHT/  
POWER-BY-WIRE  
TECHNOLOGY

# AGENDA

**March 17, 1992**

- 8:00 AM Leave Sheraton Hotel by NASA Bus
- 8:30 AM Register at Conference Center
- 9:30 AM Welcome Dr. J. F. Creedon LaRC Director for Flight Systems
- 9:45 AM Overview Mr. Felix L. Pitts LaRC FBL/PBW Technical Manager
- 10:30 AM Break
- 11:00 AM Keynote Address Mr. James Treacy, FAA National Resource Specialist
- 12:30 PM Lunch (NASA Cafeteria)
- 1:30 PM Individual Panel Sessions
- 3:00 PM Refreshments Available (Break time/duration established by panels)
- 4:45 PM Adjourn (Bus to Hotel for those not attending social)
- 5:00 PM Cash Bar / Social at the Conference Center
- 7:00 PM Bus to Hotel



FLY-BY-LIGHT/  
POWER-BY-WIRE  
TECHNOLOGY

# AGENDA

**March 18, 1992**

8:00 AM Leave Sheraton Hotel by NASA Bus  
8:30 AM Individual Panel Sessions  
10:30AM Refreshments Available (Break time/duration established by panels)  
12:30 PM Lunch (NASA Cafeteria)  
1:30 PM Plenary Session: Mid Course Summary Reports inc 5 min discussion

1:30 PM OSS Mid Course Summary Report  
2:00 PM SEPM Mid Course Summary Report  
2:20 PM EA Mid Course Summary Report  
2:40 PM EEG Mid Course Summary Report  
3:00 PM FTA Mid Course Summary Report  
3:30 BREAK  
4:00 PM EME Mid Course Summary Report  
4:30 PM SID Mid Course Summary Report  
5:00 PM OPEN FORUM

5:30 Adjourn (Bus to Hotel )  
5:30 PM Cash Bar / Social at the Conference Center  
6:30 Bus From Conference Center to Fisherman's Wharf via Hotel  
8:30 Bus to Hotel



FLY-BY-LIGHT/  
POWER-BY-WIRE  
TECHNOLOGY

# AGENDA

## March 19

- 8:00 AM Leave Sheraton Hotel by NASA Bus
- 8:30 AM Individual Panel Sessions
- 10:30 AM Refreshments Available (Break time/duration established by panels)
- 12:30 PM Lunch (NASA Cafeteria)
- 1:30 PM Plenary Session: Final Reports by Panel Chair-persons

- 1:30 PM OSS Report
- 2:00 PM SEPM Report
- 2:20 PM EA Report
- 2:40 PM EEG Report
- 3:00 PM FTA Report
- 3:30 BREAK
- 4:00 PM EME Report
- 4:30 PM SID Report

5:00 PM Adjourn



---

---

# WORKSHOP COMMITTEES

---

---





FLY-BY-LIGHT/  
POWER-BY-WIRE  
TECHNOLOGY

**OSS COMMITTEE**

## **OPTICAL SENSOR SYSTEMS**

# **OSS**

**Mr. Irv Reese**

**Boeing Commercial**

**Seattle**

**Mr. Bob Baumbick NASA LeRC**

**Mr. Jeff Bartlett RTI**



FLY-BY-LIGHT/  
POWER-BY-WIRE  
TECHNOLOGY

**PBW COMMITTEE**

**POWER-BY-WIRE**

**PBW**

**Mr. Louis Feiner**

**McDonnell Douglas, Long Beach**

**SEPM, EA, EEG Panels**

**Mr. Dave Renz      NASA LeRC**



FLY-BY-LIGHT/  
POWER-BY-WIRE  
TECHNOLOGY

SEPM Panel

# SECONDARY ELECTRICAL POWER MANAGEMENT

# SEPM

Ms. Lisa McDonald McDonnell Douglas

St. Louis

Ms. Barbara Kenny NASA LeRC

Mr. Jorge Montoya RTI



FLY-BY-LIGHT/  
POWER-BY-WIRE  
TECHNOLOGY

**EA Panel**

## **ELECTRICAL ACTUATOR PANEL**

# **EA**

**Mr. Edward Beauchamp Allied Signal**

**Torrance**

**Mr. James Muldice General Dynamics**

**San Diego**

**Ms. Mary Ellen Roth NASA LeRC**

**Mr. Ed Withers RTI**





FLY-BY-LIGHT/  
POWER-BY-WIRE  
TECHNOLOGY

**FTA COMMITTEE**

## **FAULT TOLERANT ARCHITECTURE**

# **FTA**

**Mr. Dagfinn Gangsaas**  
**Boeing Defense and Space**  
**Seattle**

**Mr. Dan Palumbo** **NASA LaRC**  
**Ms. Charlotte Scheper** **RTI**



FLY-BY-LIGHT/  
POWER-BY-WIRE  
TECHNOLOGY

**EME COMMITTEE**

---

# **ELECTROMAGNETIC ENVIRONMENT**

# **EME**

**Mr. Richard Hess**  
**Honeywell Air Transport Systems**  
**Phoenix**

**Mr. Felix Pitts NASA LaRC**  
**Mr. Aubrey Cross RTI**



FLY-BY-LIGHT/  
POWER-BY-WIRE  
TECHNOLOGY

**SID COMMITTEE**

# **SYSTEM INTEGRATION and DEMONSTRATION**

# **SID**

**Mr. John Todd  
McDonnell Douglas  
Long Beach**

**Mr. Cary Spitzer NASA LaRC  
Dr. Bob Baker RTI**





# CHALLENGE

- **ACCOMMODATE / ACCOUNT FOR SYNERGISTIC SENSOR / ARCHITECTURE / ACTUATOR / POWER REQUIREMENTS**
  - **IDENTIFY DRIVERS FROM EACH VIEWPOINT**
  - **RESOLVE CONFLICTS**
  - **ARRIVE AT COMPATIBLE SET OF REQUIREMENTS**
- **ACCOMPLISH AGAINST BACKDROP OF COST / MANUFACTURABILITY / FLIGHTWORTHINESS / CERTIFIABILITY**
- **SUCCESSFUL TECHNOLOGY TRANSFER**

FLY-BY-LIGHT/  
POWER-BY-WIRE  
TECHNOLOGY

# CHALLENGE

TECHNOLOGY TRANSFER

CERTIFICATION REQUIREMENTS

TECHNICAL REQUIREMENTS

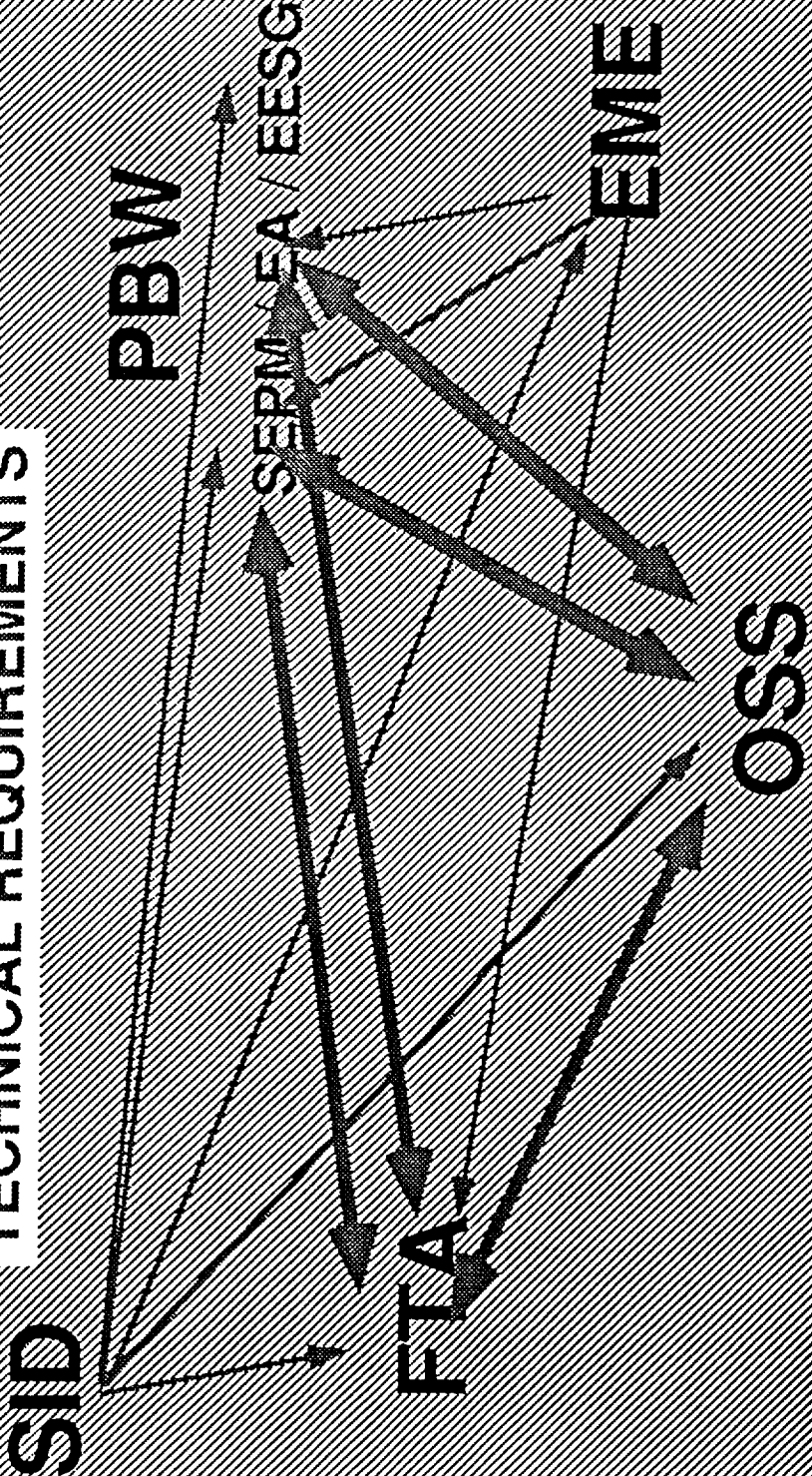



FLY-BY-LIGHT/  
POWER-BY-WIRE  
TECHNOLOGY

# SESSION TOPICS AND ACTIVITIES

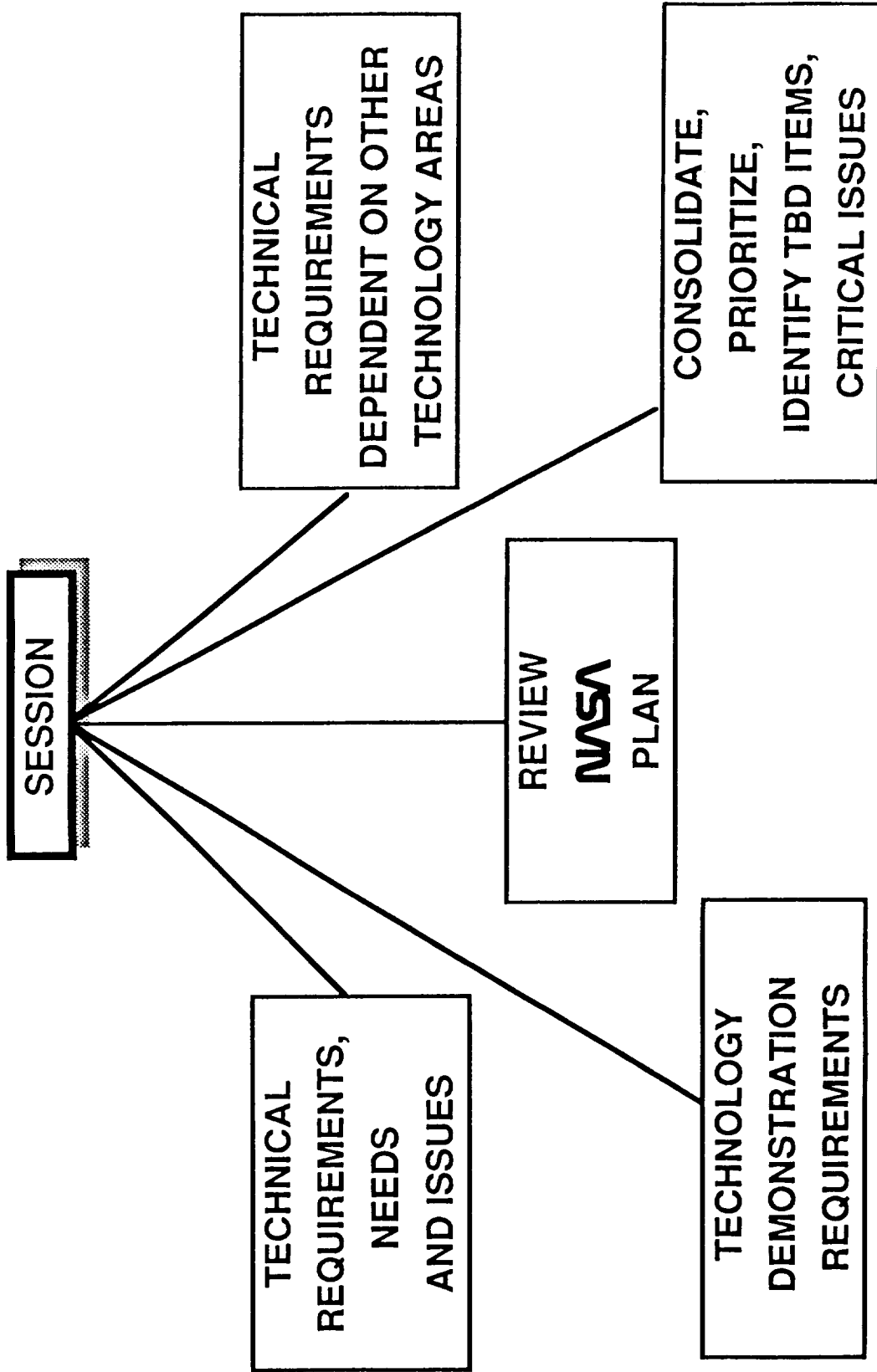



FLY-BY-LIGHT/  
POWER-BY-WIRE  
TECHNOLOGY

REQUIREMENTS CATEGORIES FOR SESSIONS

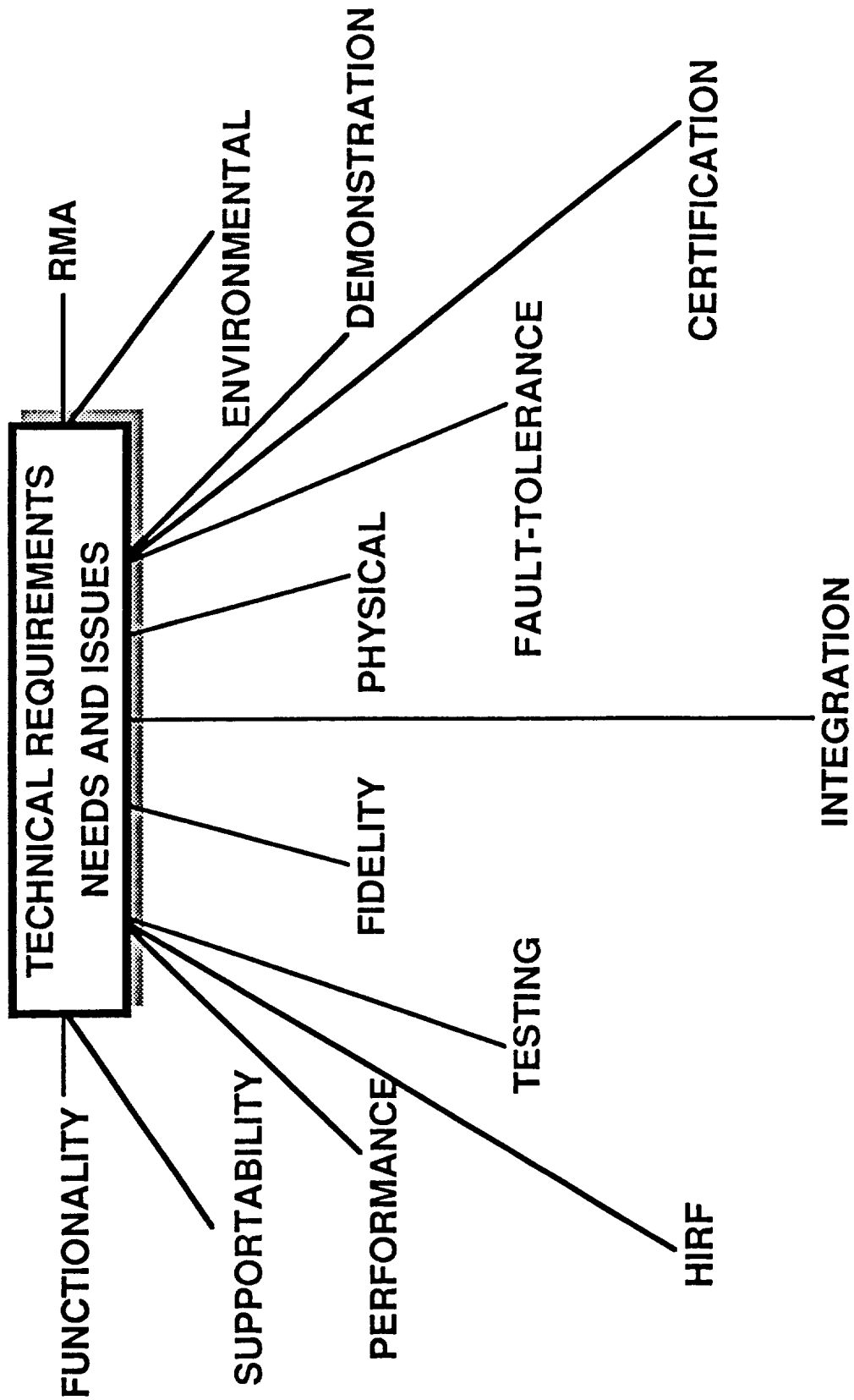

**PBW Systems Panel Sessions Technical Work Plan - Louis  
Feiner**

---

---

# NASA Highly Reliable FBL/PBW

## Requirements and Technology Workshop

---

---

### Power-by-Wire Systems

#### Panel Sessions

#### Technical Work Plan

<b>PBW</b>	<i>Gale Sundberg... Program Overview</i>
<i>Dave Renz</i>	<i>Dick Quigley..... MEA</i>
<i>Lou Feiner</i>	<i>Tom Jahns..... Starter/gen AF CRAD</i>
	<i>Lou Feiner..... 400 Hz AI-Elec CRAD</i>
	<i>(Open Forum)..... 5-7 min /Co.</i>
<b>SEPM</b>	<b>EESG</b>
<i>Lisa McDonald</i>	<i>Rick Rudey</i>
<i>(TBD)</i>	<i>Tom Jahns</i>
	<b>EA</b>
	<i>Ed Beauchamp</i>
	<i>Jim Mildice</i>

**March 17-19, 1992**

---

---

# Overall Generic Secondary Power System Architecture

NASA Power-by-Wire Systems (PBW) Workshop

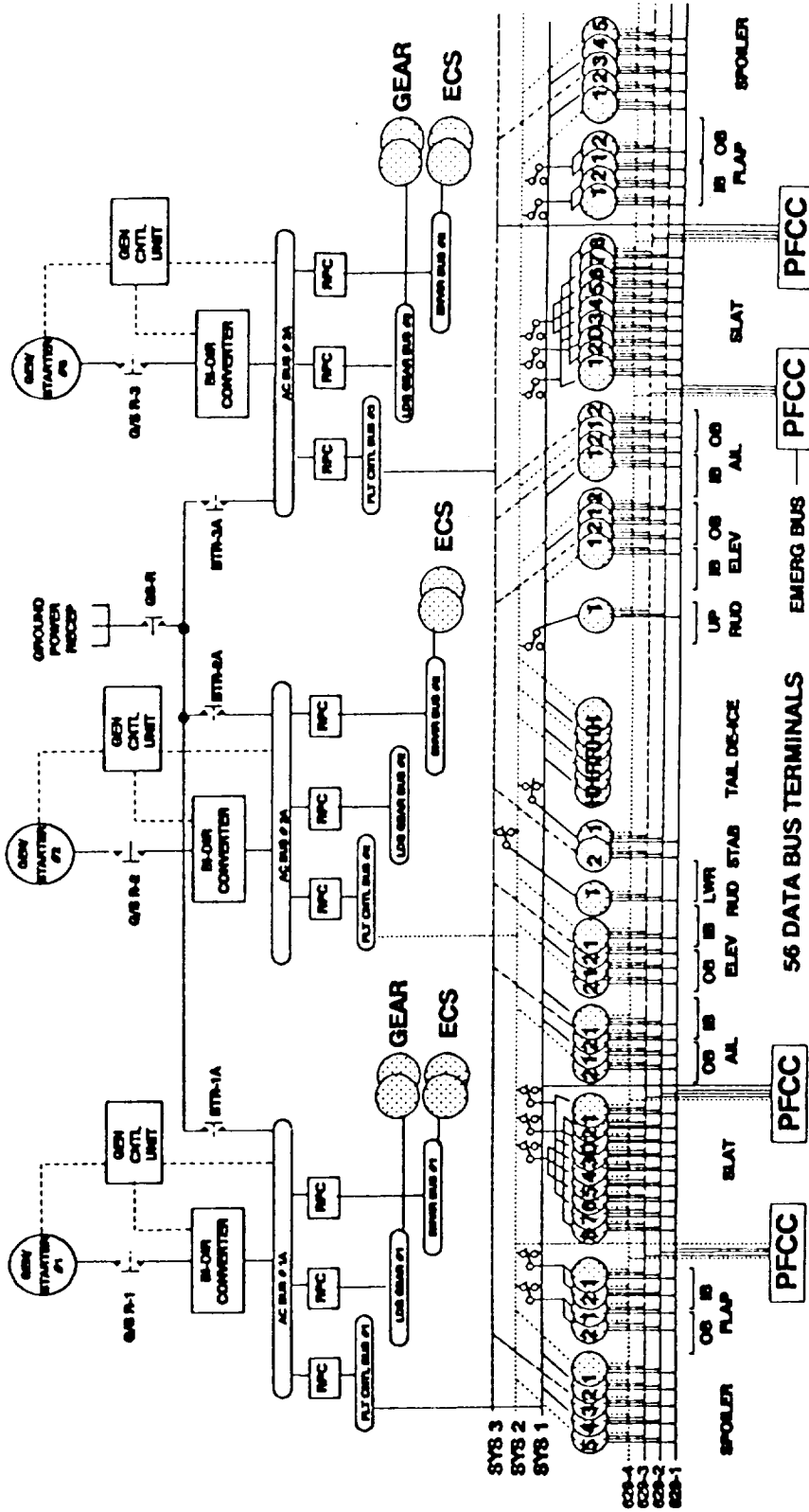

---

---

# Check List for NASA Stated Objectives

for PBW Workshop

---

---

## Overall

- 1. PBW program requirements
- 2. Concurrence on PBW program
- 3. Concurrence on certification simplification
- 4. Methods for transfer to production
- 5. Priorities to effect production transition
- 6. Key coordination issues for other work groups

## Specific

- 1. Measure system application state of readiness
- 2. Measure component state of readiness
- 3. Identify system development needs
- 4. Identify component development needs
- 5. Identify system integration development needs
- 6. Scope out industry roadmap for all-electric aircraft

## Issues

- 1. Recommended test bed
  - 2. PBW program designed to prove tech readiness
  - 3. Technology level, fault tolerance, redundancy, BIT, smart actuators
  - 4. Pros/cons PBW competing technologies
  - 5. Technology readiness time frame - 1996 or later
- 
-



# PBW Workshop Information Flow Process

NASA Power-by-Wire Systems (PBW) Workshop

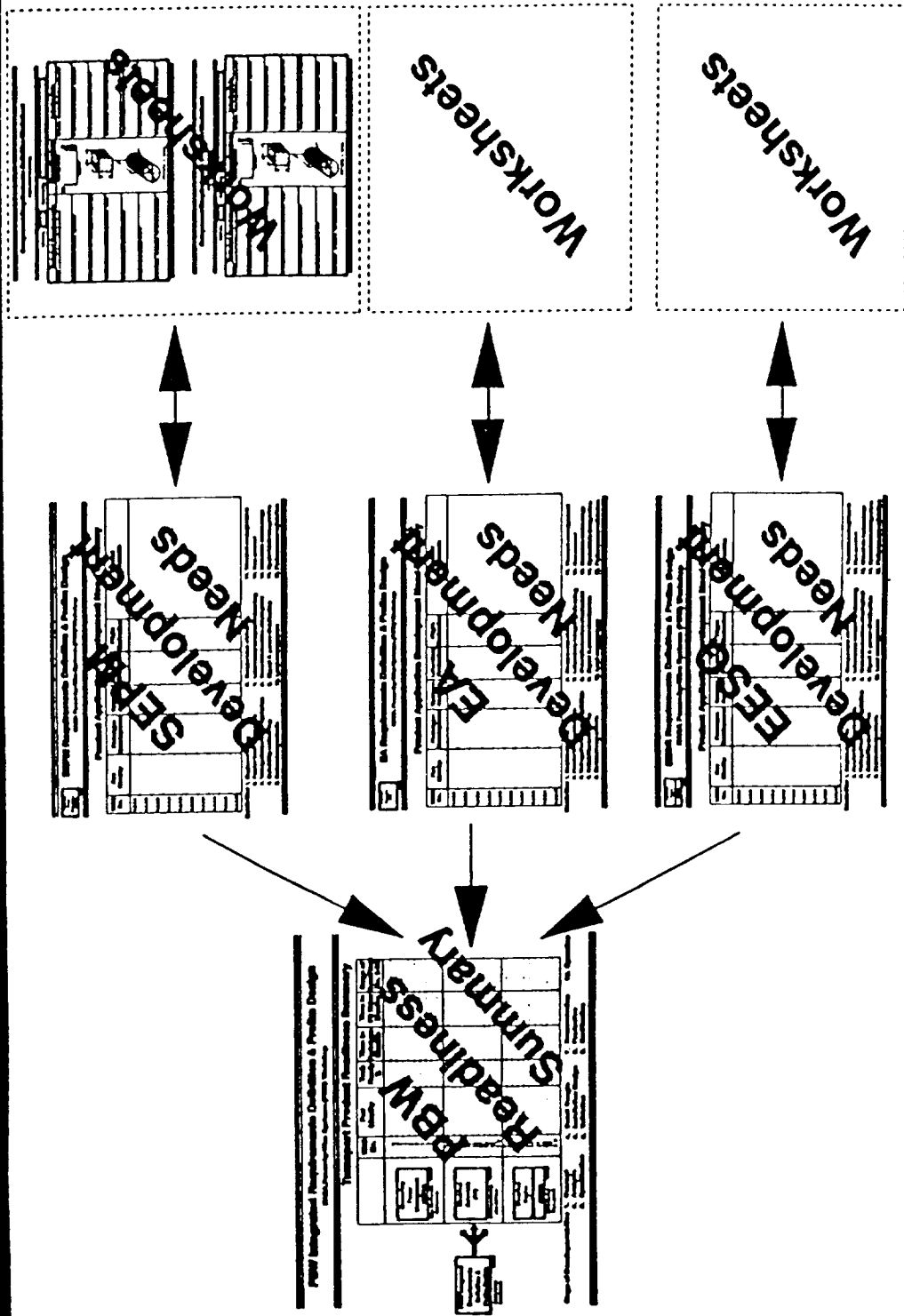

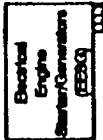

# EESG Requirements Definition & Prelim Design NASA Power-by-Wire Systems (PBW) Workshop

## Product Application Development Need Summary

WBS No.	Part Identity	Prototype Development	Systems Analysis	Laboratory Evaluation	Flight Evaluation	General Comments
1.1.1.1	Heat exchanger					
1.1.1.2	Mounting pad					
1.1.1.3	Starter/generator					
1.1.1.4	Current xfrmr					
1.1.1.5	Generator ctrl unit					
1.1.1.6	Generator relay					
1.1.1.7	Bus tie relay					
1.1.1.8	BI-dlr converter					
1.1.1.9						
1.1.1.10						

- Needs No.:**
- 1. Engine starting
  - 2. Feeder fault protection
  - 3. Voltage/frequency regulation
  - 4. Reliability estimating
  - 5. Redundancy criteria
  - 6. Component sizing
  - 7. Laboratory integration/testing
  - 8. Crew information display/ctrl
  - 9. Signal & power distribution
  - 10. Load management
  - 11. Thermal management
  - 12. Bus control
  - 13. Materials technology
  - 14. Sys/vehicle integration
  - 15. Performance validation

# EA Requirements Definition & Prelim Design

NASA Power-by-Wire Systems (PBW) Workshop

## Product Application Development Need Summary

WBS No.	Part Identity	Prototype Development	Systems Analysis	Laboratory Evaluation	Flight Evaluation	General Comments
1.1.3.1	Mechanical linkage					
1.1.3.2	Mechanical drive					
1.1.3.3	Elect/mech brake					
1.1.3.4	Hyd servo pump					
1.1.3.5	Hydraulic reservoir					
1.1.3.6	Electric motor					
1.1.3.7	Elect ctrl module					
1.1.3.8	Prim fit ctrl emptr					
1.1.3.9	ECS compressor					
1.1.3.10	Landing Gear Pump					

- Needs No.:**
1. Engine starting
  2. Feeder fault protection
  3. Voltage/frequency regulation
  4. Reliability estimating
  5. Redundancy criteria
  6. Component sizing
  7. Laboratory integration/testing
  8. Crew information display/ctrl
  9. Signal & power distribution
  10. Load management
  11. Thermal management
  12. Bus control
  13. Materials technology
  14. Sys/vehicle integration
  15. Performance validation

# PBW Panel Work Process and Output Timing

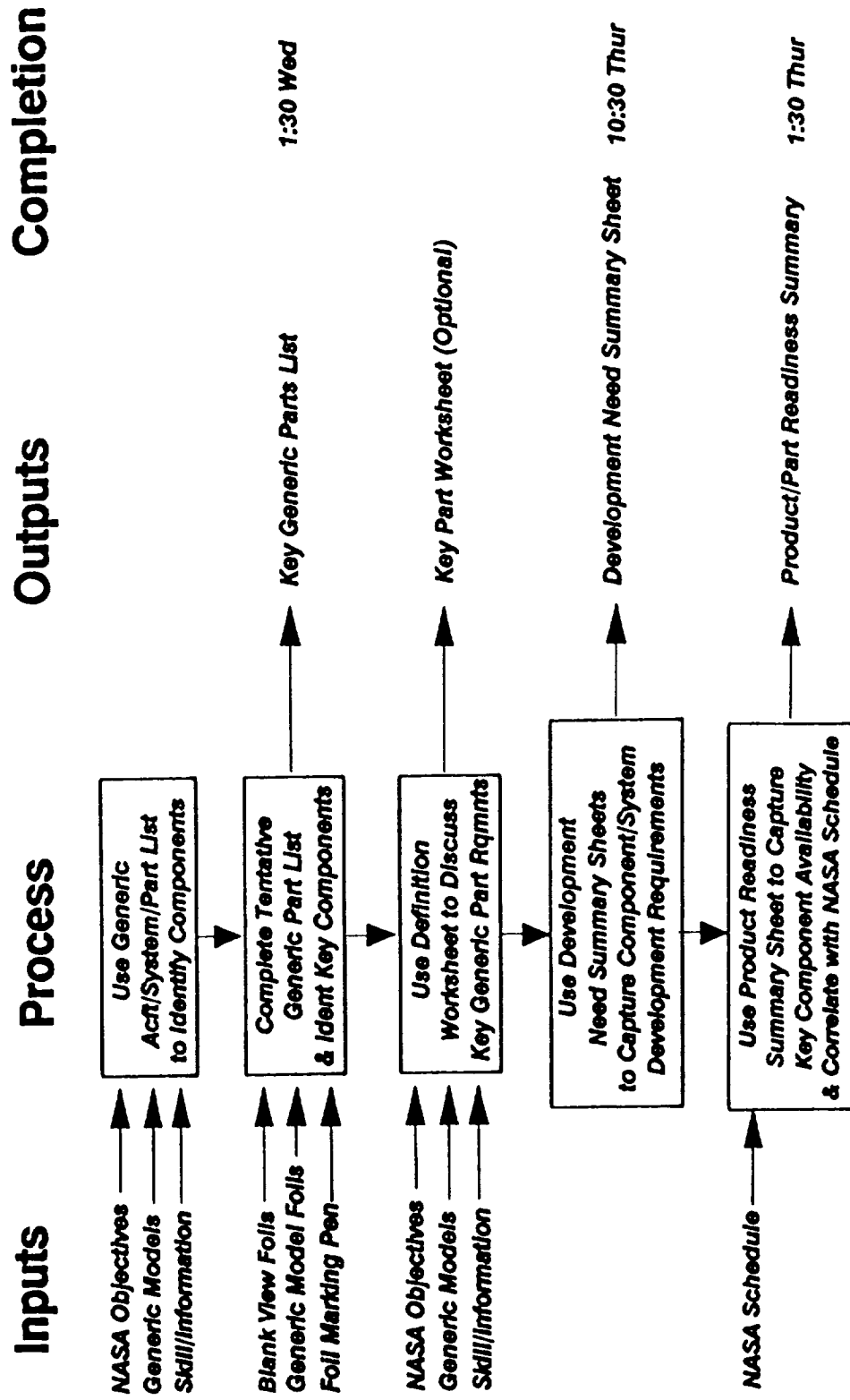

# Requirements Definition & Prelim Design

NASA Power-by-Wire Systems (PBW) Workshop

## Product Application Development Need Summary

WBS No.	Part Identity	Prototype Development	Systems Analysis	Laboratory Evaluation	Flight Evaluation	General Comments

- Needs No.:**
- 1. Engine starting
  - 2. Feeder fault protection
  - 3. Voltage/frequency regulation
  - 4. Reliability estimating
  - 5. Redundancy criteria
  - 6. Component sizing
  - 7. Laboratory integration/testing
  - 8. Crew information display/ctrl
  - 9. Signal & power distribution
  - 10. Load management
  - 11. Thermal management
  - 12. Bus control
  - 13. Materials technology
  - 14. Sys/vehicle integration
  - 15. Performance validation

<b>Milestone Number</b>	<b>Date</b>	<b>Description</b>
1.1	FY92, 2Q	Requirements Definition Workshop
1.2	FY93, 3Q	Requirements/Preliminary Design Defined (requirements sent to LaRC/LeRC for #'s 2.1, 3.1, 4.1 and 5.1)
2.1	FY93, 4Q	FBL sensors Selected, Architectural Design
2.2	FY95, 4Q	FBL Hardware Environmental Test
2.3	FY96, 4Q	Engine Sensor Ground Test (Optical components sent to LaRC for Integration and Demo, #6.2)
2.4	FY98, 4Q	FBL closed-loop flight test completed
3.1	FY93, 3Q	Define Power Management and Distribution (PMAD) for Power By Wire system
3.2	FY95, 1Q	PMAD designed, and Electrical Actuator (EA) fabricated
3.3	FY96, 2Q	Test PMAD and fabricate generator
3.4	FY96, 4Q	End-to-end ground test (PBW system sent to LaRC for Integration and Demo, #6.2)
3.5	FY97, 3Q	Complete testing of engine/generator combination
3.6	FY98, 4Q	PBW closed-loop flight test completed
4.1	FY93, 4Q	Specify fault-tolerant architecture
4.2	FY95, 3Q	Laboratory fabrication
4.3	FY96, 3Q	Reliability validation complete (Fault tolerant architecture ready for test, #6.2)
5.1	FY93, 4Q	Select codes
5.2	FY94, 4Q	Laboratory complete
5.3	FY95, 3Q	Laboratory-verify codes
5.4	FY96, 2Q	Aircraft-verify codes (EME assessment methods are transferred to fault-tolerant architecture in time for #4.3)
6.1	FY96, 1Q	Integrate sensors, architecture and PMAD
6.2	FY97, 1Q	FBL/PBW end-to-end ground tests
6.3	FY97, 4Q	EME validation
6.4	FY98, 4Q	FBL/PBW flight test and evaluation of selected sub-systems

# Schedule

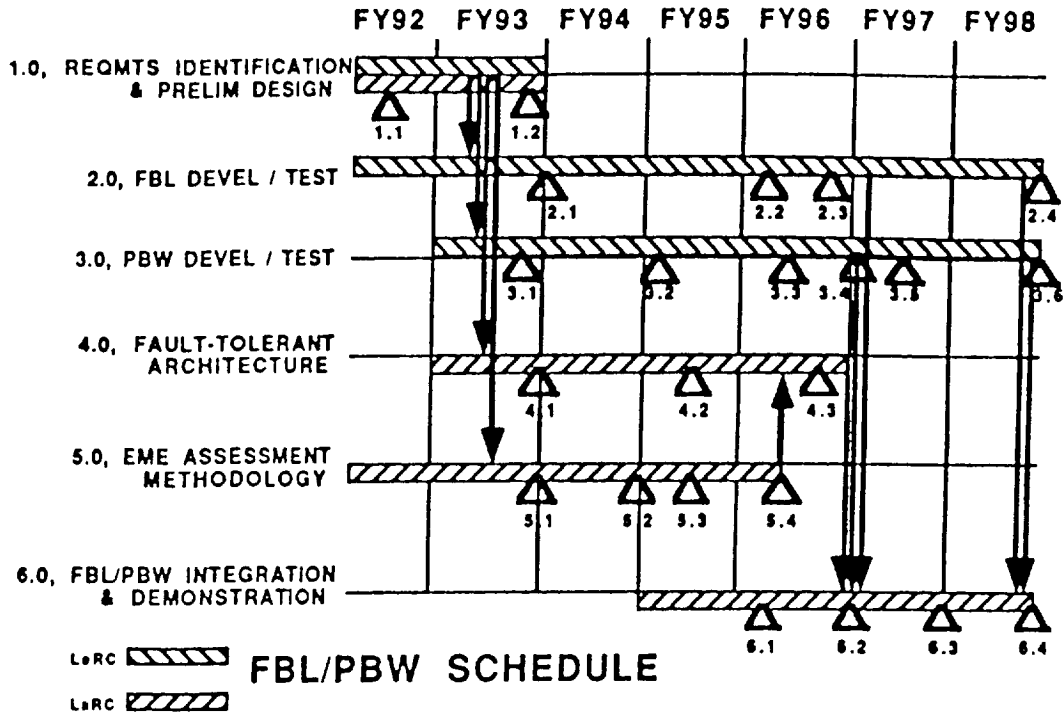

Milestone Number	Date	Description
1.1	FY92, 2Q	Requirements Definition Workshop
1.2	FY93, 3Q	Requirements/Preliminary Design Defined (requirements sent to LaRC/LeRC for #'s 2.1, 3.1, 4.1 and 5.1)
2.1	FY93, 4Q	FBL sensors Selected, Architectural Design
2.2	FY95, 4Q	FBL Hardware Environmental Test
2.3	FY96, 4Q	Engine Sensor Ground Test (Optical components sent to LaRC for Integration and Demo, #6.2)
2.4	FY98, 4Q	FBL closed-loop flight test completed
3.1	FY93, 3Q	Define Power Management and Distribution (PMAD) for Power By Wire system
3.2	FY95, 1Q	PMAD designed, and Electrical Actuator (EA) fabricated
3.3	FY96, 2Q	Test PMAD and fabricate generator
3.4	FY96, 4Q	End-to-end ground test (PBW system sent to LaRC for Integration and Demo, #6.2)
3.5	FY97, 3Q	Complete testing of engine/generator combination
3.6	FY98, 4Q	PBW closed-loop flight test completed
4.1	FY93, 4Q	Specify fault-tolerant architecture
4.2	FY95, 3Q	Laboratory fabrication
4.3	FY96, 3Q	Reliability validation complete (Fault tolerant architecture ready for test, #6.2)
5.1	FY93, 4Q	Select codes
5.2	FY94, 4Q	Laboratory complete
5.3	FY95, 3Q	Laboratory-verify codes
5.4	FY96, 2Q	Aircraft-verify codes (EME assessment methods are transferred to fault-tolerant architecture in time for #4.3)
6.1	FY96, 1Q	Integrate sensors, architecture and PMAD
6.2	FY97, 1Q	FBL/PBW end-to-end ground tests
6.3	FY97, 4Q	EME validation
6.4	FY98, 4Q	FBL/PBW flight test and evaluation of selected sub-systems

**Highly Reliable PBW Aircraft Technology Program Overview**  
**- Gale Sundberg**



***HIGHLY RELIABLE POWER-BY-WIRE AIRCRAFT  
TECHNOLOGY PROGRAM OVERVIEW***

C-37

**GALE R. SUNDBERG  
NASA LEWIS RESEARCH CENTER  
CLEVELAND, OHIO 44135**

**PBW PANEL SESSION  
NASA LANGLEY RESEARCH CENTER  
HAMPTON, VIRGINIA**

MARCH 17, 1992

GRS92-003.1

## AGENDA

OAST AERONAUTICS STRATEGIC THRUSTS

C-38

BACKGROUND

PROGRAM PLAN

MANAGEMENT OPTIONS

WHAT DO WE NEED FROM YOU?

**U. S. COMPETITIVENESS**

**"INDUSTRY EXPERTS SAY NASA MUST DEVOTE MORE  
RESOURCES TO CIVIL AERONAUTICS"** Aviation Week 2/24/92

C-39

**WHY?**

**U. S. MARKETSHARE OF LARGE  
CIVIL TRANSPORTS IS FALLING!**

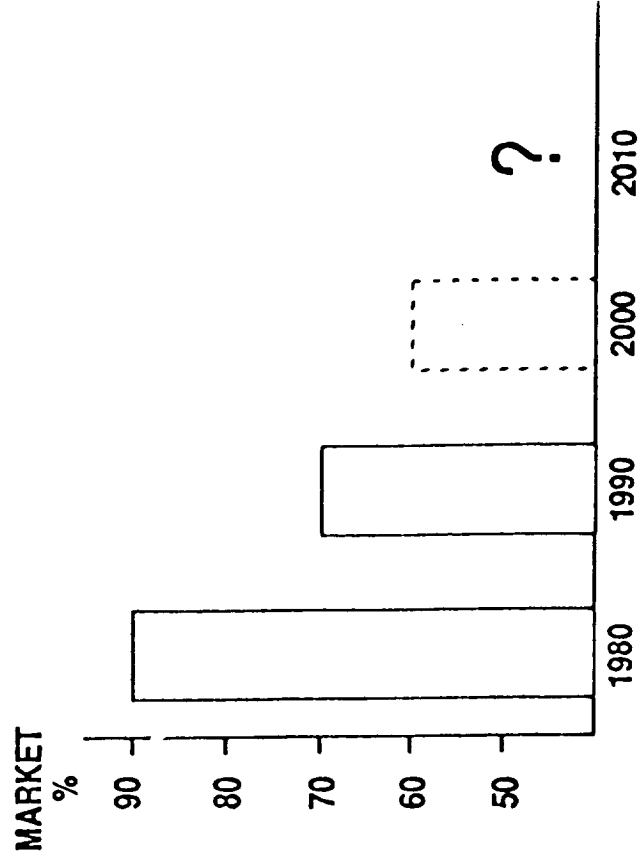

**WE ARE LOSING MARKETS IN ...**

- AIRCRAFT INDUSTRY
  - AIRBUS
  - OTHERS (?)
- ELECTRONICS INDUSTRIES
  - POWER ELECTRONICS AND SEMICONDUCTORS
  - ADVANCED MOTORS & DRIVERS
  - SOLID STATE LOGIC AND COMPUTERS
  - PHOTONICS
  - MECHATRONICS

**CAN WE SUCCEED WITH BUSINESS AS USUAL?**

## GLOBAL COST ISSUES DRIVE TECHNOLOGY

- IMPROVE U. S. COMPETITIVE POSITION
- LOWER AIRLINE CAPITAL INVESTMENT
- REDUCE DIRECT OPERATING COSTS
  - REDUCE WEIGHT/FUEL CONSUMPTION
  - INCREASE RELIABILITY
  - IMPROVE SCHEDULE PERFORMANCE

## NASA OAST AERONAUTICS STRATEGIC THRUSTS

### Thrust #1 - SUBSONIC AIRCRAFT / NATIONAL AIRSPACE

DEVELOP SELECTED, HIGH-LEVERAGE TECHNOLOGIES AND EXPLORE  
NEW MEANS TO ENSURE THE COMPETITIVENESS OF U. S. SUBSONIC  
AIRCRAFT AND TO ENHANCE THE SAFETY AND PRODUCTIVITY OF THE  
NATIONAL AVIATION SYSTEM

C-42

### Objective 2:

DEVELOP, IN COOPERATION WITH U. S. INDUSTRY, SELECTED HIGH-PAYOFF  
TECHNOLOGIES THAT CAN ENABLE SIGNIFICANT IMPROVEMENTS IN  
AIRCRAFT EFFICIENCY AND COST

HIGHLY-RELIABLE FLY-BY-LIGHT AND POWER-BY-WIRE FLIGHT SYSTEMS

## **MEMORANDUM OF UNDERSTANDING**

- NASA-DOD JOINT COMMANDERS WORKING GROUP
- NATIONAL TEAM FOR MORE-ELECTRIC-AIRCRAFT
- SHARE TECHNOLOGY, DATA AND EXPERTISE
- AVOID DUPLICATION
- LEVERAGE EACH AGENCIES FUNDING AND IMPACT

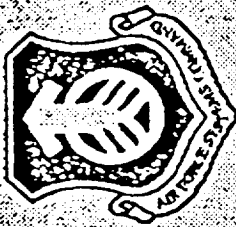

BACKGROUND

MORE ELEC A/C



# INDUSTRY/DOD/NASA FOCUS

## TRISERVICE/NASA MORE-ELECTRIC PLANNING PROVIDING FOCUS AND GUIDANCE TO IR&D

— AIR FORCE: MORE-ELECTRIC AIRCRAFT (AFSC/WL - \$3 - 4M/YR, RAMTIP - \$3 - 4M/YR, OC-ALC - \$2 - .3M/YR)

- JOINT STUDIES AND ELEC POWER ACTUATOR DEV (EPAD) - (WL, NAVY, NASA)
- C-130, C-141, F/A-18 - ELEC ACTUATOR (WL, RAMTIP, OC-ALC, NAVY, NASA)
- MAINTENANCE-FREE BATTERY (WL, HQ SAC/LGM, RAMTIP)
- ELECTRIC POWER GENERATION/DISTRIBUTION "COPPER BIRD" DEMO COMPONENTS

— NAVY: MORE-ELECTRIC AIRCRAFT, SHIPS AND SUBMARINES (\$2 - .6M/YR)

- ACFT: 270 VDC POWER, GENERATORS, ELECTRIC ACTUATION
- SHIPS: ELIMINATE GEARS, USE MODULE DRIVE, ELECTRIC ACTUATION

— ARMY: MORE-ELECTRIC TANKS AND HELICOPTERS (\$2 - .5M/YR)

- TANK: ALL-ELECTRIC TURBINE ENGINE, ACTUATORS
- HELICOPTERS: ELECTRIC TAIL ROTOR DRIVE, INLET PARTICLE SEPARATOR, ROTOR ACTUATION

— NASA: MORE-ELECTRIC COMMERCIAL TRANSPORTS, LAUNCH SYSTEMS (\$5 - 1.0M/YR)

- TRANSPORTS, FLY-BY-LIGHT
- ADVANCED LAUNCH SYS/SHUTTLE ELECTRIC ACTUATION

— INDUSTRY: MORE-ELECTRIC CRITICAL TECHNOLOGY DEVELOPMENT - \$50M/YR IR&D, 30-40 CONTRACTORS



=====

# BACKGROUND

=====



## PBW STUDY RESULTS

- LOCKHEED, TECHNOLOGY UPGRADES, 500 PASSENGER (1980)
  - 0.15 CENTS/SEAT MILE SAVINGS - ADVANCED ENGINES
  - 0.17 CENTS/SEAT MILE SAVINGS - ALL-ELECTRIC SECONDARY POWER
  
- LeRC IN-HOUSE, ADVANCED 20 kHz POWER SYSTEM (1985)
  - 7 - 10% REDUCTION IN TOGW AND  $\Delta$  FUEL
  
- DOUGLAS AIRCRAFT, CURRENT TECHNOLOGY (1991)
  - 2% REDUCTION IN
    - FUEL BURN
    - TOGW
    - DOC
  - INCREASED RELIABILITY
  - ADVANCED TECHNOLOGY (1992)

# TECHNOLOGY UPGRADES vs COST 500 PASSENGER AIRCRAFT

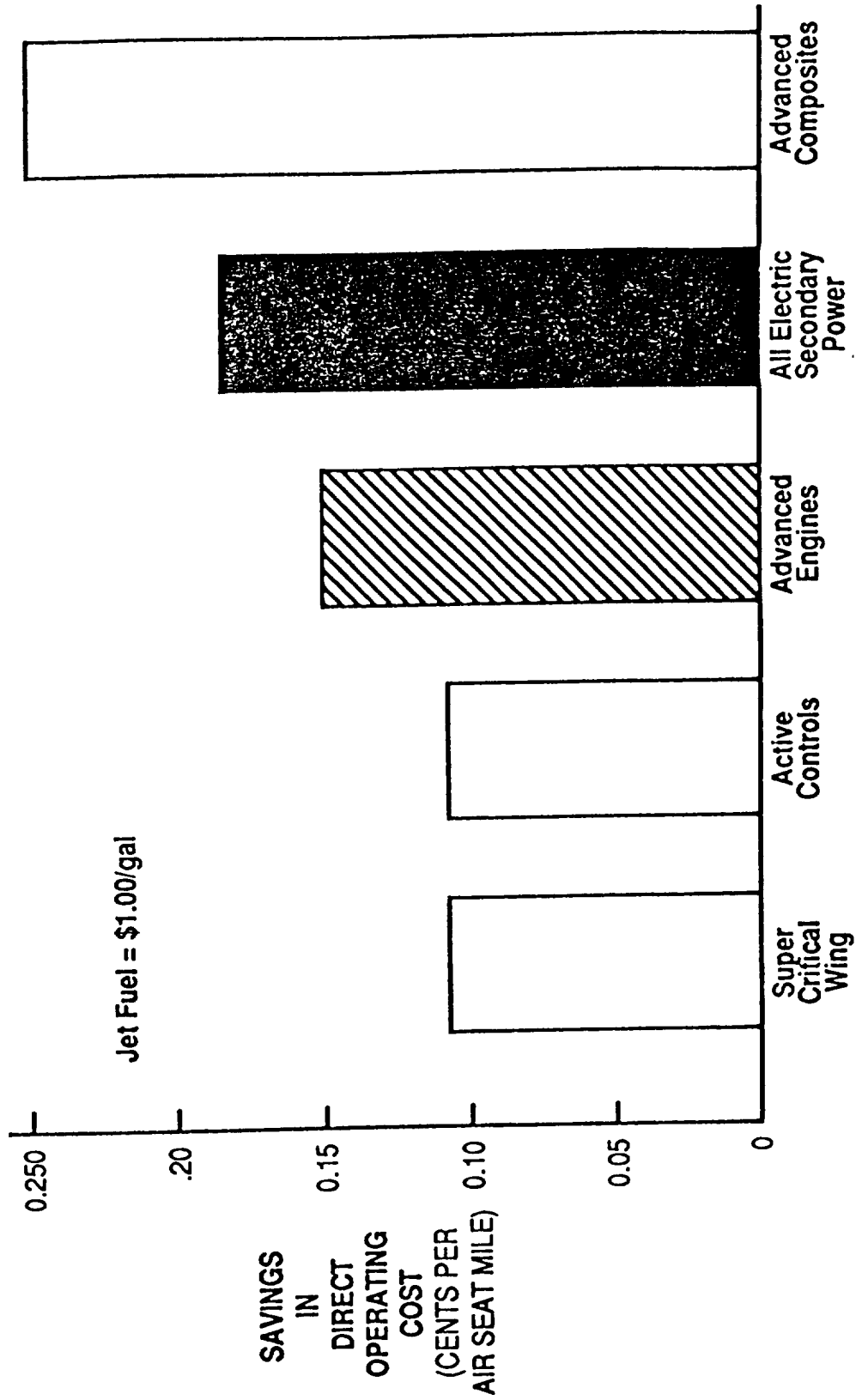

Based on Lockheed Study, December, 1980



Aerospace Technology Directorate



# POWER-BY-WIRE TECHNOLOGY

## LeRC ALL-ELECTRIC POWER SYSTEM STUDY

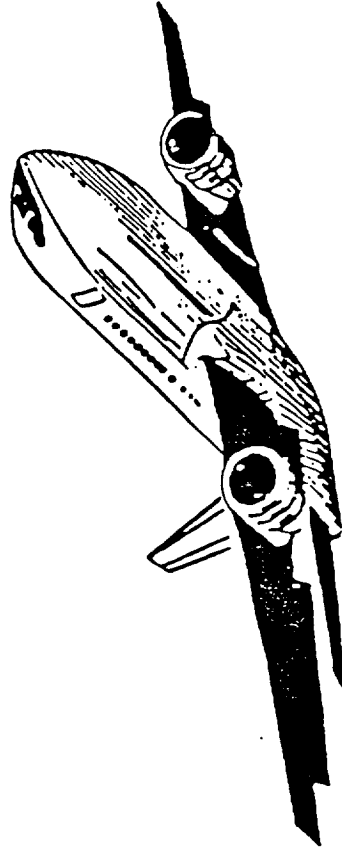

<b>CONCLUSIONS</b>
<b>PBW SAVES</b>
10% AIRCRAFT WEIGHT
10% FUEL USAGE

<b>BOEING 767 BASIS</b>
ADVANCED HIGH FREQUENCY ELECTRICAL SYSTEM
REPLACES HYDRAULIC, PNEUMATIC AND CONVENTIONAL ELECTRICAL SYSTEMS

USES INTEGRAL STARTER/GENERATOR; ELECTRIC ACTUATION AND ENVIRONMENTAL CONTROL SYSTEM; VARIABLE SPEED PUMPS
• IMPROVED OPERABILITY, MAINTAINABILITY AND RELIABILITY
USES ENERGY EFFICIENT ENGINE TECHNOLOGY
• ELIMINATES VARIABLE BLEED PENALTY
• SMALLER ENGINES, STRUCTURE



PLANNING

MORE-ELEC A/C

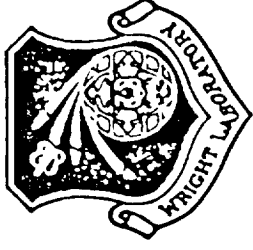

# CRITICAL TECHNOLOGIES

## ULTRA-RELIABLE, ENVIRONMENTALLY TOLERANT POWER CONTROLLERS/ POWER ELECTRONICS KEY TO THIS INITIATIVE

- POWER GENERATION
  - LARGE INTERNAL/EXTERNAL STARTER/GENERATOR/POWER CONTROLLER -- ENGINE INTEGRATION, PACKAGING, THERMAL MANAGEMENT, RELIABILITY ASSESSMENT, FAULT TOLERANCE
  - INTEGRATED POWER UNIT/POWER CONTROLLER -- ULTRA-RELIABLE AUXILIARY/EMERGENCY POWER
  - LIFE-OF-THE-AIRCRAFT (20 YEAR) BATTERY/SMART CHARGER -- MAINTENANCE FREE, RELIABILITY ASSESSMENT, REDUCED ACQUISITION COST
- POWER DISTRIBUTION/CONTROL
  - REMOTE TERMINAL/POWER CONTROLLERS - PACKAGING, ENVIRONMENTAL CONSTRAINTS, COOLING, RELIABILITY ASSESSMENT, ADVANCED CONTROL TECHNIQUES (PHOTONICS, CONTROL-BY-LIGHT), EMI
  - 2 - 3X FAULT TOLERANCE - SOLID STATE POWER CONTROLLERS, INTEGRATION/PACKAGING/MANAGEMENT/CONTROL
- POWER UTILIZATION
  - HI HORSEPOWER STABILATOR ACTUATOR/POWER CONTROLLER - STIFFNESS, POWER, RESPONSE, RELIABILITY ASSESSMENT, INTEGRAL REDUNDANCY
  - ACTUATORS/POWER CONTROLLER - LIGHTWEIGHT, MAINTAINABLE, LRU, THERMAL MANAGEMENT, RELIABILITY ASSESSMENT, INTEGRAL REDUNDANCY, ADV CONTROL TECHNIQUES (PHOTONICS, FBL)
  - BRAKES/POWER CONTROLLER - PACKAGING, INTEGRATION/CONTROL
- INTEGRATION -- EXTENSIVE GROUND TEST, SELECTIVE FLIGHT TEST

1497203

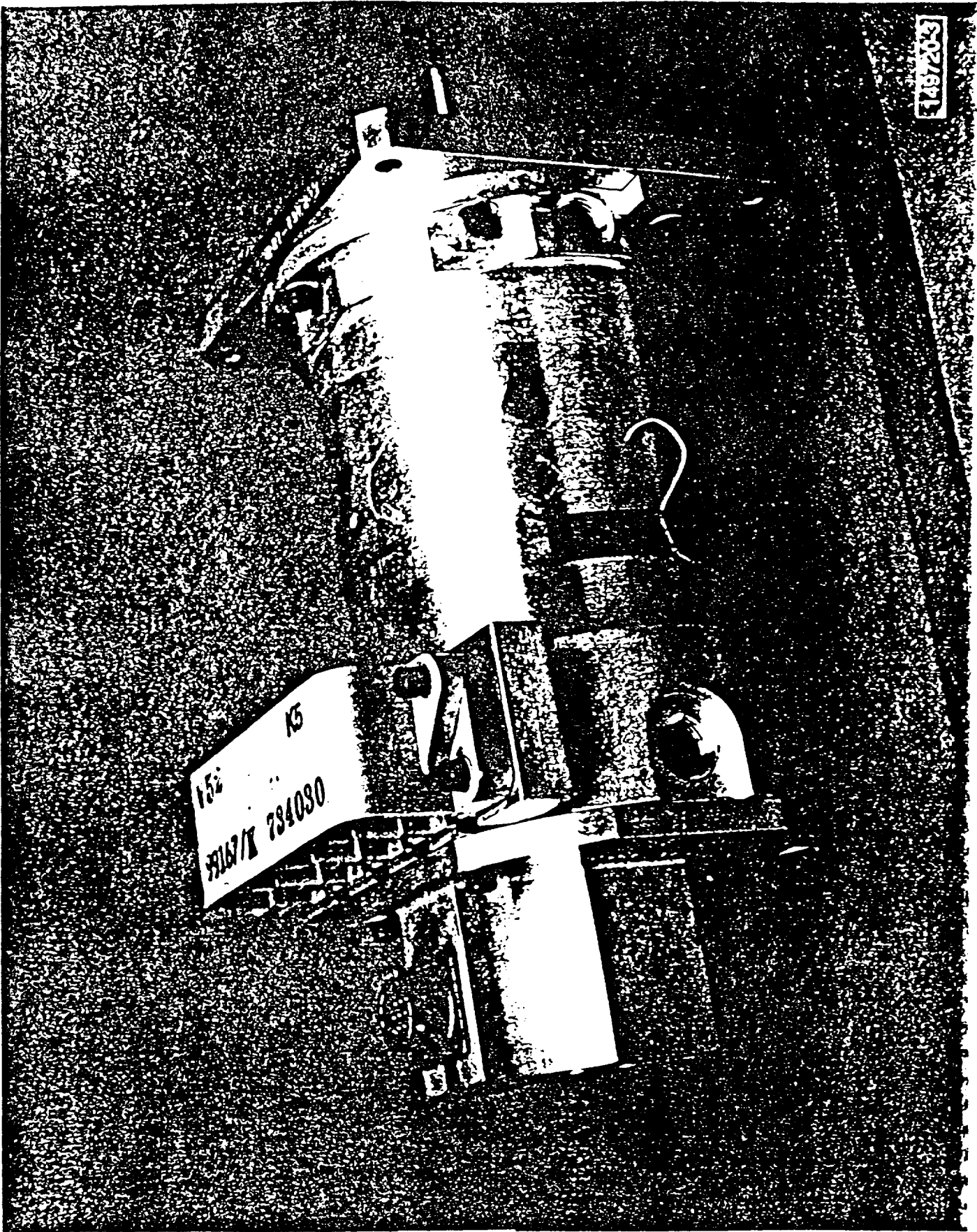

=====

C-51

# PBW PROGRAM PLAN

=====



# FLY-BY-LIGHT/POWER-BY-WIRE SUBSONIC TRANSPORT AIRCRAFT

REDUCES WEIGHT, FUEL CONSUMPTION, LIFECYCLE COSTS

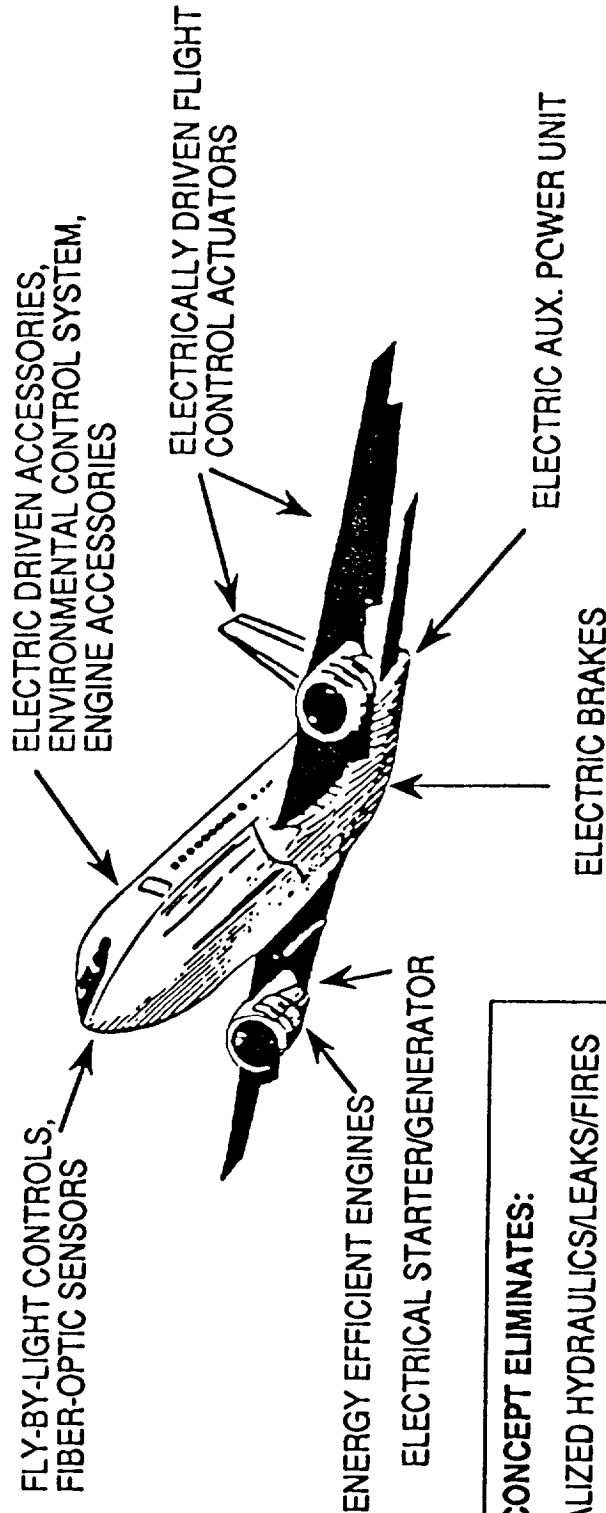

- CONCEPT ELIMINATES:**
- CENTRALIZED HYDRAULICS/LEAKS/FIRES
  - ACCESSORY DRIVE GEARBOXES
  - CONSTANT SPEED DRIVE
  - VARIABLE AIR BLEED
  - LIGHTNING, EMI SUSCEPTIBILITY
  - LOW SUBSYSTEM UTILIZATION



# THE WORK BREAKDOWN STRUCTURE

## FBL/PBW WBS RELATIONSHIPS

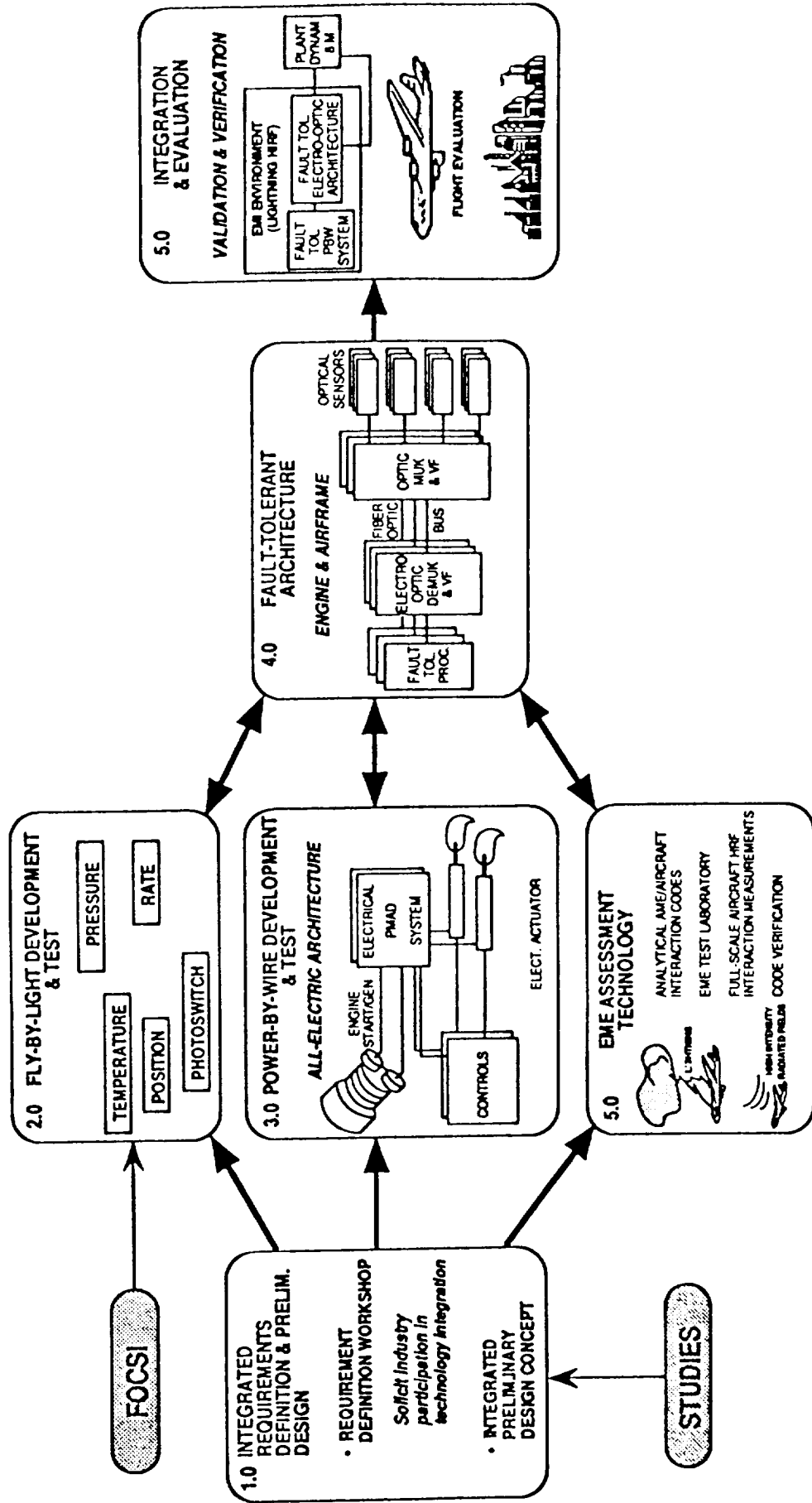

WBS 3.0 PBW DEVELOPMENT AND DEMONSTRATION

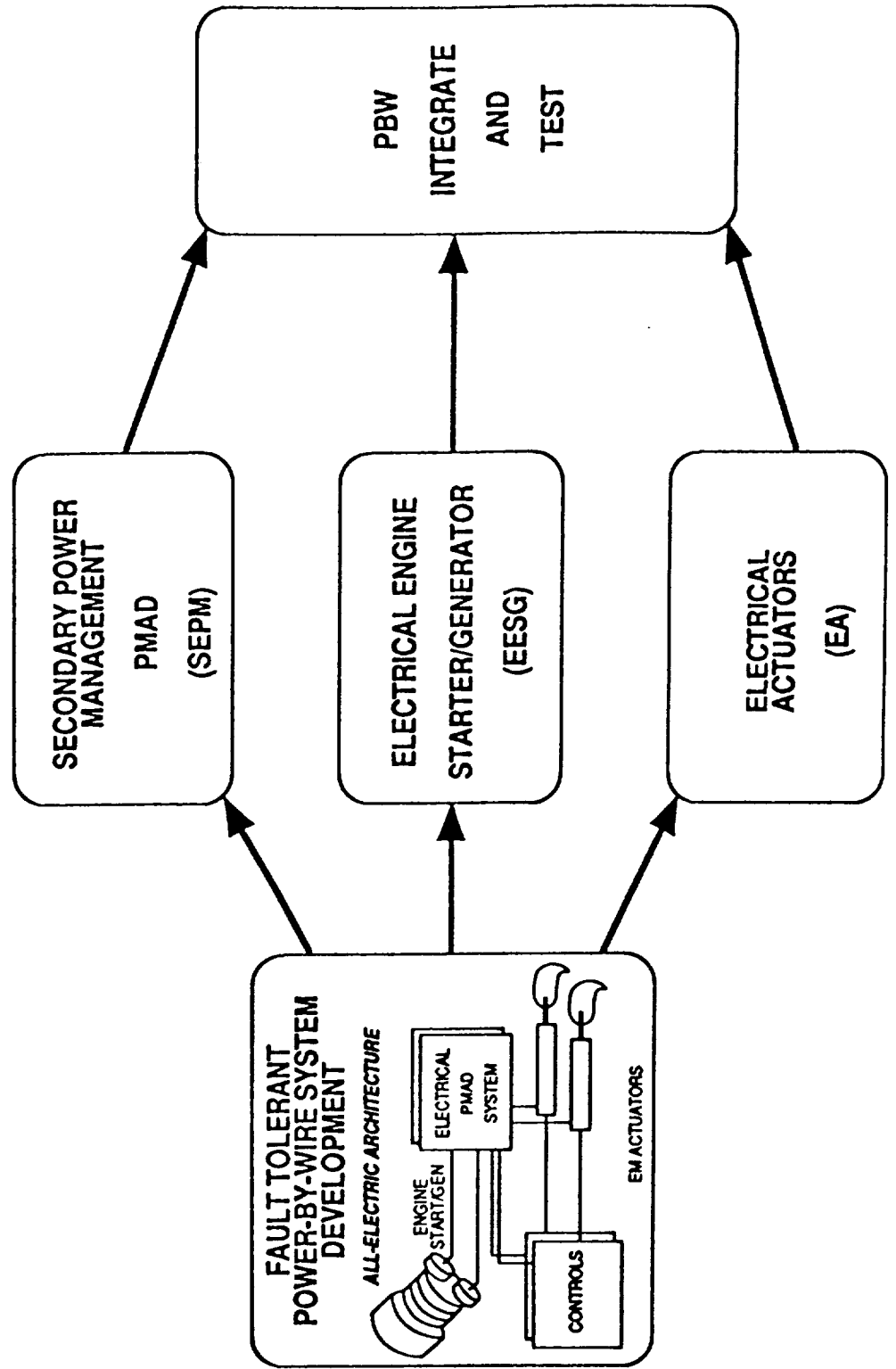

**WBS 3.0 PBW DEVELOP AND TEST ALL-ELECTRIC POWER SYSTEM,  
COMPONENTS AND EMA'S**

	92	93	94	95	96	97	98
<b>3.1 DEFINE PMAD</b>		_____					
<b>3.2 DESIGN PMAD</b>		_____	_____				
<b>3.3 FAB &amp; TEST PMAD</b>			_____	_____	_____		
<b>3.4 DES/FAB ENG ST/GEN</b>			_____	_____	_____		
<b>3.5 GND TST ENG ST/GEN</b>				_____	_____	_____	
<b>3.6 ADAPT EXIST EMA TECH &amp; FAB EMA'S</b>		_____	_____				
<b>3.7 TEST PMAD, ST/GEN, EMA SYS</b>				_____	_____	_____	
<b>3.8 INTEG SEL PMAD &amp; EMA FOR FLIGHT TEST</b>						_____	_____

=====

# PROGRAM MANAGEMENT OPTIONS

=====

C-56

C-3

## PBW TECHNOLOGY CONCEPT

- SUPPORT AIRFRAME CONFIGURATION/CONCEPT REQUIREMENTS
- AVAILABLE TO SUPPORT NEXT GENERATIONS
- PRODUCTS SUPPORT KEY DESIGN/DECISION POINTS
- RESULTS IN HARDWARE, TESTBED AND FLIGHT DEMOS
- MANAGED BY LeRC TECHNICAL PROJECT LEADERS
- EXECUTED BY AIRFRAMERS, COMPONENT/SUBSYSTEM CONTRACTORS AND NASA LABS
- INTEGRATION AND INTERFACE WITH FBL TECHNOLOGIES

PROGRAM MANAGEMENT OPTIONS

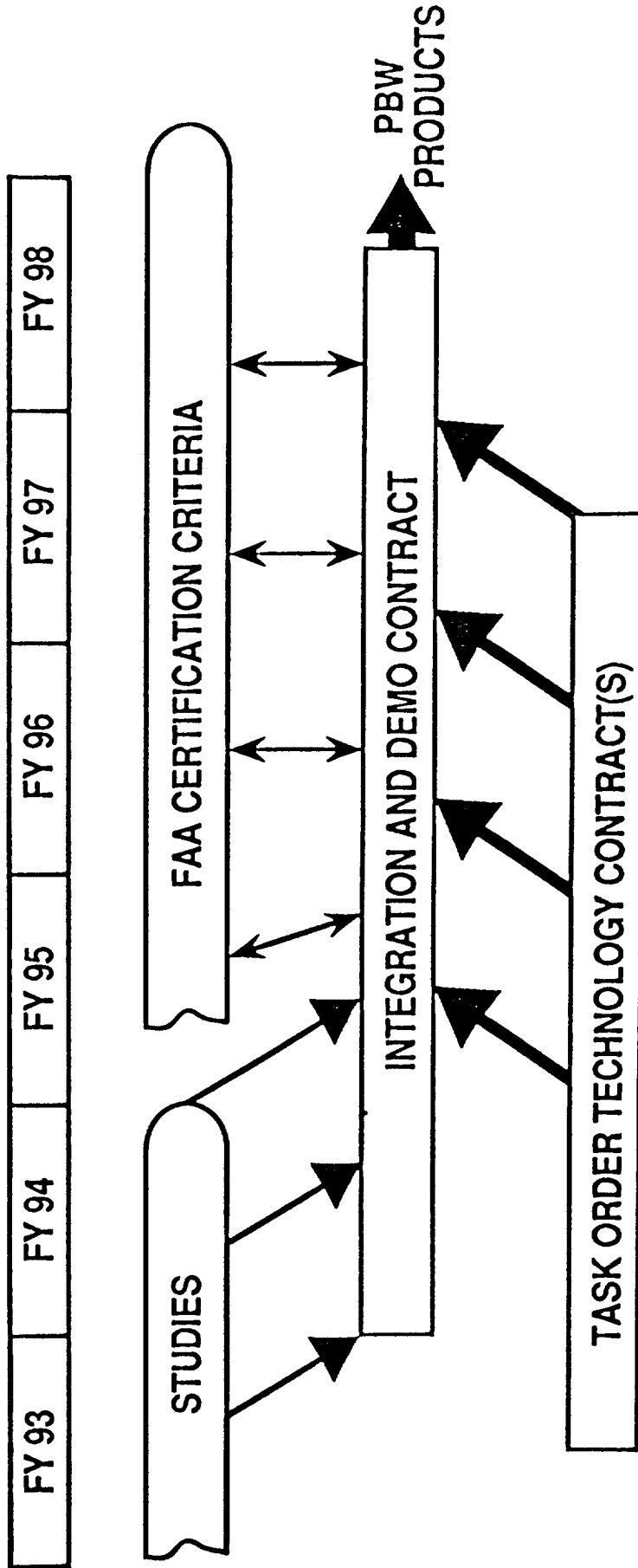

## WHAT WE NEED FROM YOU ..

- DEFINE CRITICAL REQUIREMENTS
- KEY INTERFACE ISSUES
- TECHNOLOGY INSERTION ISSUES AND TIMING
- TECHNOLOGY ROADMAP
- ROLES: NASA, INDUSTRY, FAA, AIRLINES
- CRITIQUE, COMMENTS ON WBS
- TEST-BEDS - GROUND BASED AND FLIGHT

## **FBL/PBW PROGRAM SUMMARY**

- **A CATALYST TO CIVIL AERONAUTICS**
- **A CHANGE TO REVITALIZE**
  - **THE TECHNOLOGY**
  - **THE INDUSTRY**
  - **THE APPROACH TO SUBSONIC TRANSPORTS**



## Electromagnetic Environment - Felix Pitts

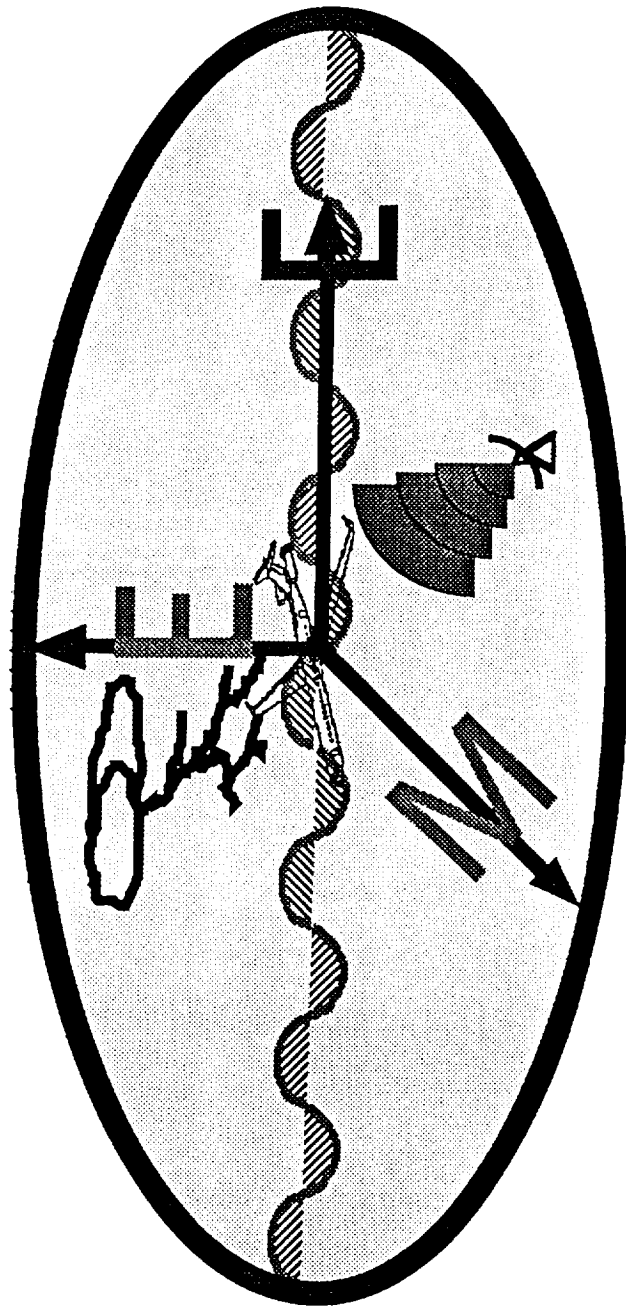

FELIX L. PITTS

NASA  
LANGLEY RESEARCH CENTER



FLY-BY-LIGHT/  
POWER-BY-WIRE  
TECHNOLOGY

# FBL/PBW APPROACH

## FOCSI

**OPTICAL SENSOR  
DEVELOPMENT  
& EVALUATION**

PRESSURE

TEMP.

RATE

POSITION

PHOTOSWITCH

**FAULT-TOLERANT ELECTRO-OPTIC  
ARCHITECTURE DESIGN  
& SENSOR INTEGRATION**

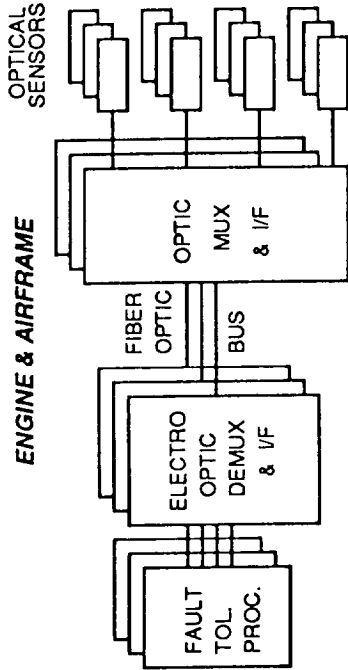

**INTEGRATED SYSTEM  
VALIDATION AND VERIFICATION**

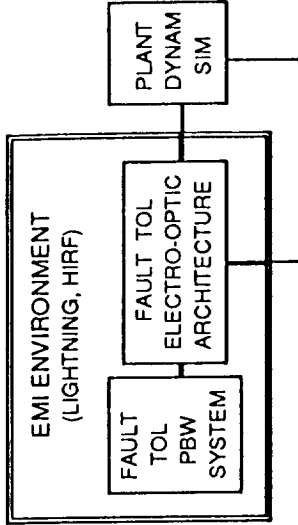

**FAULT TOLERANT  
POWER-BY-WIRE SYSTEM  
DEVELOPMENT**

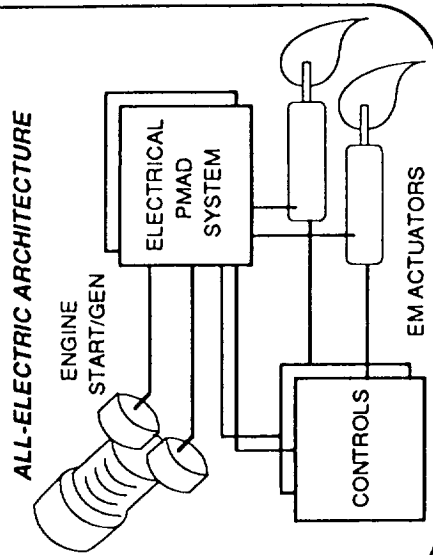

**COMPONENT  
FLIGHT EVALUATION**

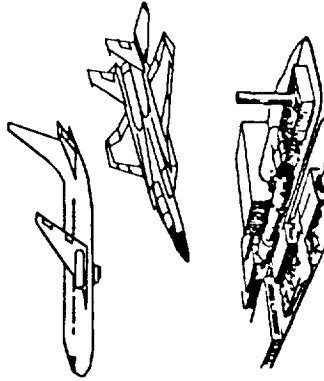

**ELECTROMAGNETIC  
ENVIRONMENT (EME)  
ASSESSMENT METHODOLOGY**

ANALYTICAL EME/AIRCRAFT  
INTERACTION CODES

EME TEST LABORATORY

FULL-SCALE AIRCRAFT HIRF  
INTERACTION MEASUREMENTS

CODE VERIFICATION

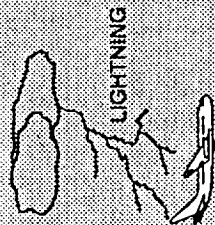

LIGHTNING

HIGH INTENSITY  
RADIATED FIELDS



FLY-BY-LIGHT/  
POWER-BY-WIRE  
TECHNOLOGY

EME ASSESSMENT METHODOLOGY

- DEVELOP ANALYTICAL EME/AIRCRAFT INTERACTION CODES
- DEVELOP EME TEST LABORATORY
  - MEASURE CANONICAL FORMS
  - MEASURE SCALED AIRCRAFT
- PERFORM FULL-SCALE AIRCRAFT HIRF MEASUREMENTS
- VERIFY EME CODES AGAINST LABORATORY AND AIRCRAFT DATA



- 5.0 DEVELOP VALIDATED EME ASSESSMENT METHODOLOGY
  - 5.1 SELECT PRELIMINARY EME ANALYTICAL CODES
  - 5.2 DEVELOP EME LABORATORY
  - 5.3 VERIFY FINAL EME CODES WITH LABORATORY TESTS
  - 5.4 VERIFY FINAL EME CODES WITH AIRCRAFT TESTS



FLY-BY-LIGHT/  
POWER-BY-WIRE  
TECHNOLOGY

HIGH INTENSITY RADIATED FIELDS  
(HIRE)

- **The man-made electromagnetic threat to critical electronic systems aboard advanced aircraft**

C-66

- Radars
- Radio Broadcast Transmitters
- Other Emitters of Electromagnetic Energy



FLY-BY-LIGHT/  
POWER-BY-WIRE  
TECHNOLOGY

HIRF THREAT to ADVANCED AIRCRAFT

- **Composite Structures**
  - Less Shielding than All Metal
- **Flight-Critical Controls**
  - Higher Reliability Requirements than Non-Critical Controls
- **Digital Control Systems**
  - More Sensitive to Transients than Analog
  - Can Cease Correct Operation without Component Damage

***Upsets Cannot Be Tolerated  
in Advanced Aircraft Systems***

- **Lawrence Livermore Transport Aircraft Internal EME**
- **LaRC HIRF Assessment**
  - **Bendix Quad Flight Control System (Loan)**
  - **AIRLAB HIRF Test Facility**
- **Polytechnic University In-Service Fault Data Study**
  - **Motivated By Dec. 1988 Workshop**
  - **HIRF Faults**





# HIRF OVERVIEW

- **FAA Commissioned SAE-AE-4R Committee 12/88**
  - **Advisory Circular and Users Manual for Hazards of Electromagnetic Radiation to Aircraft**
  - **Chair: Stan Schneider, Boeing Military Airplane Co.**
  - **Secretary: Noel Sargent, LeRC**
  - **Three Sub-Committees**
    - Environment (Chair: Ron Rodgers, ALPA)**
    - Advisory Circular (Chair: Chris Kendall, CKC Consultants)**
    - Users Manual (Chair: Fred Heather, Patuxent River NAS)**
  - **Status: Final Meeting 1/92**
  - **SAE Report Spring 1992**
  - **Problems**
    - **How to Use and Apply, How to Treat Critical versus Essential Systems**
    - **Need Lab/Bench Tests**
    - **Research Opportunities**
    - **Modeling and Test Techniques**

# INTERNAL EME

## OBJECTIVE:

Develop a baseline internal Electromagnetic Environment (EME) assessment methodology for the proposed Fly-By-Light/Power-By-Wire augmentation

## APPROACH:

Apply Lawrence Livermore National Laboratory (LLNL) weapons system High Power Microwave EME assessment technology to transport aircraft

- Model EM interactions using LLNL codes
- Validate model with experimental data

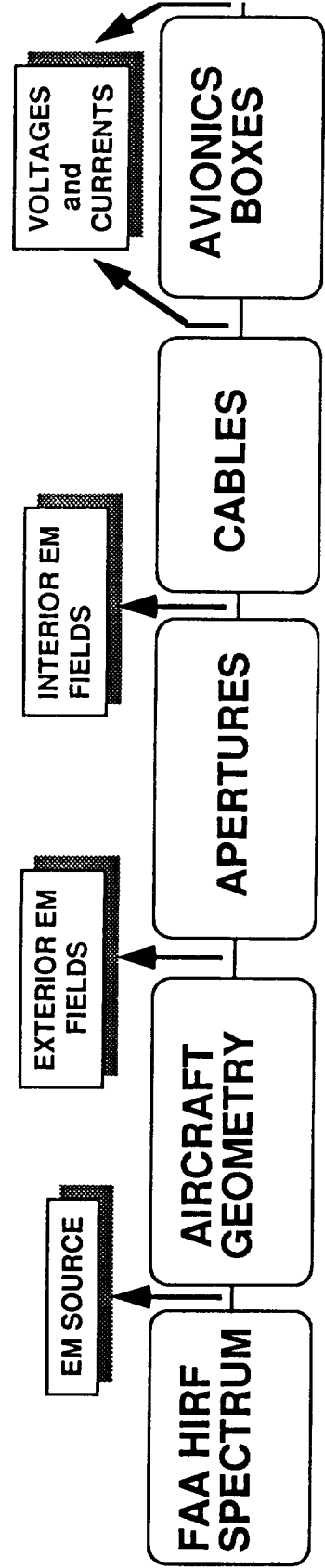



FLY-BY-LIGHT/  
POWER-BY-WIRE  
TECHNOLOGY

# EM MODELING

## TEMPORAL SCATTERING & RESPONSE EM MODELING

LAWRENCE LIVERMORE EM CODES

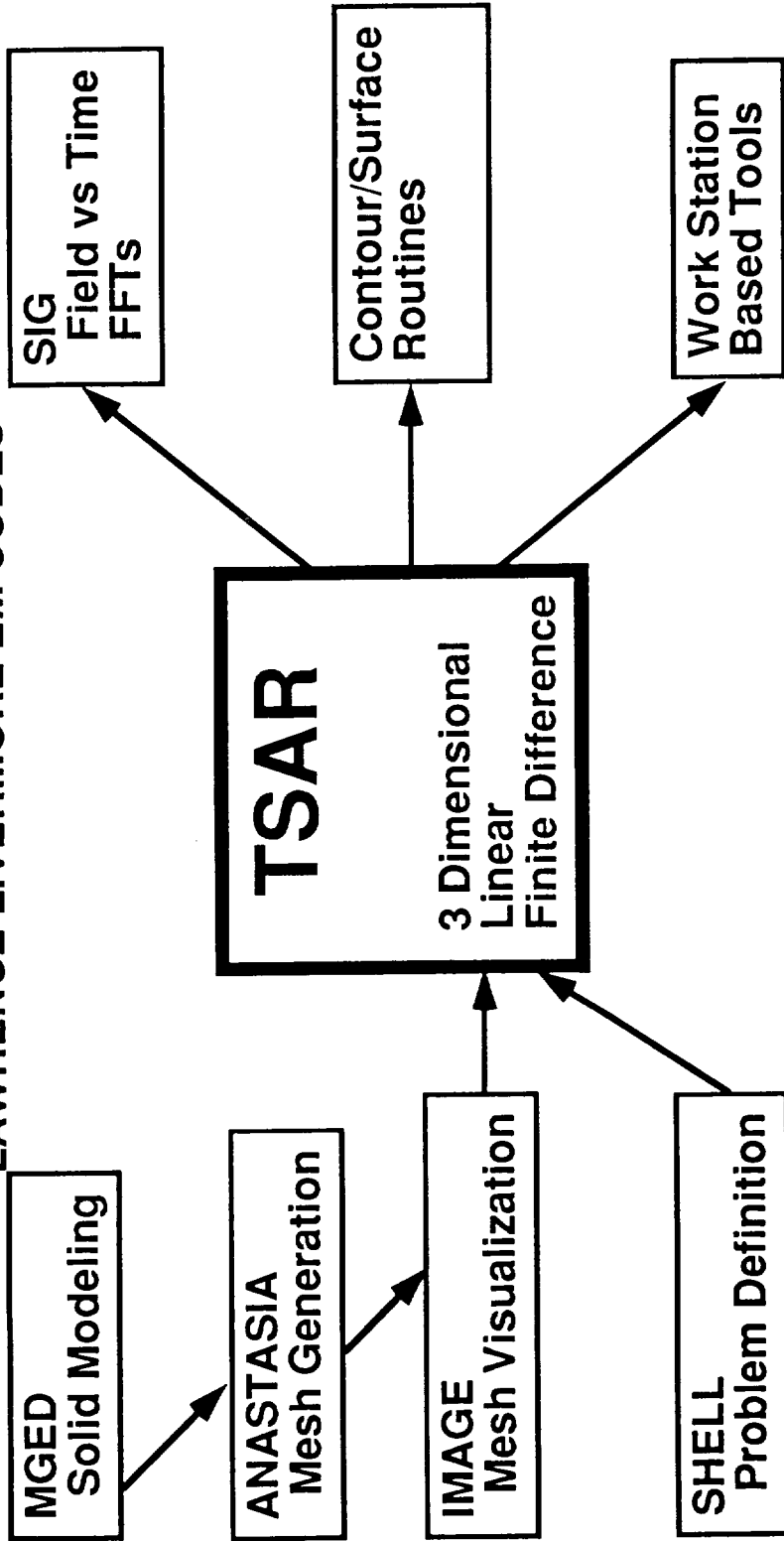

PRE-PROCESSING

PHYSICS

POST-PROCESSING

# **HIRF ASSESSMENT**

- **Allied Signal/Bendix (ASB) Loan of Quad FCC to LaRC for HIRF Studies**
  - **LaRC 737 Control Laws**
- **LaRC Develop AIRLAB HIRF Assessment Laboratory**
  - **LaRC Fabrication**
  - **Peer Review by SAE-AE 4R Committee**
- **ASB Kickoff Meeting at LaRC 5/91**

# HIRF LAB

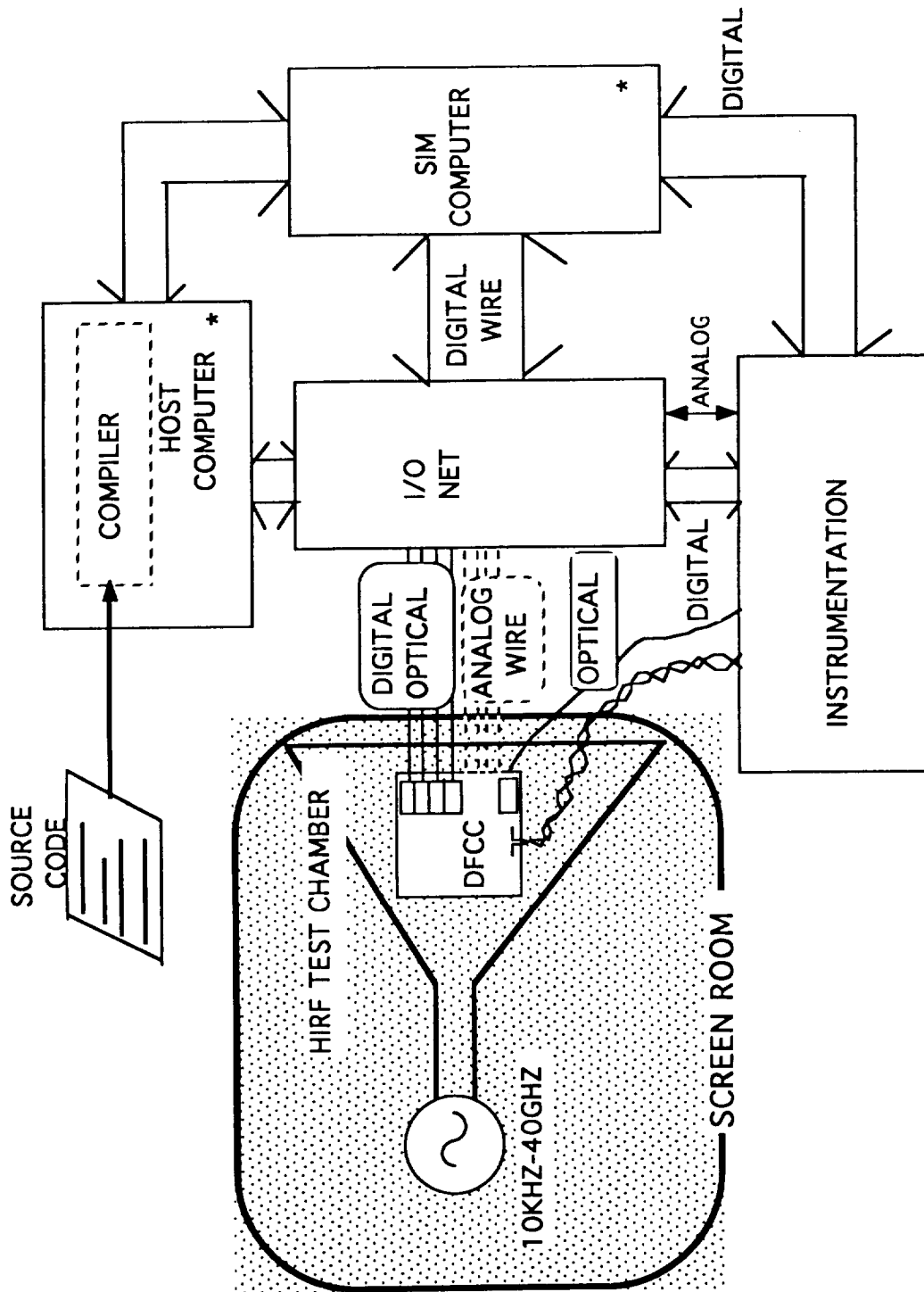

\* HOST AND SIM MAY BE SAME COMPUTER

# **IN-SERVICE FAULT DATA**

- **Subjective Study of Causes, Frequency of Occurrence, and Effects of HIRF Upsets**
- **Dr. Martin Shooman: Polytechnic University (Formerly Brooklyn Polytechnic)**
  - **Chaired Reliable Software Working Group at Flight Crucial Workshop**
  - **Pioneered "Expert Opinion" Approach to Reliability and Safety Data**
- **Attempt to Address the Question " Is There a HIRF Problem" by Focusing on Probability of Occurrence and Consequences Rather than Physics**
- **Approach is Referred to as "Consensus Estimation" Obtained from Expert's Anonymous Response to Inquiry**
- **June 1991 Kickoff**

## APPENDIX D: Workshop Correspondence

Invitation Letter

General Letter to Chairpersons

Letter to OSS Panel Principles

Letter to PBW Panel Principles

## Invitation Letter



«DATA addresses»  
113

«company»  
«attention»  
«street»«if street»  
«ENDIF»«street2»«IF street2»  
«ENDIF»«city», «state» «zip»

Subject: Fly-By-Light/Power-By-Wire Workshop

The NASA Langley Research Center is conducting a workshop on Fly-By-Light/Power-By-Wire (FBL/PBW) Requirements and Technology in support of the new NASA FBL/PBW Program. The workshop is scheduled for March 17-19, 1992, at the H. J. E. Reid Conference Center, NASA Langley Research Center, Hampton, VA.

This workshop is an integral part of the NASA FBL/PBW Program which has been developed by NASA Headquarters, NASA Langley Research Center (LaRC), and NASA Lewis Research Center (LeRC). The points of contact and responsibilities for the FBL/PBW program are: (1) NASA Headquarters--Herbert W. Schlickemaier, Program Manager; (2) LaRC--Charles W. Meissner, Jr., LaRC Program Manager; Felix L. Pitts, LaRC FBL/PBW Technical Program Manager; and Cary R. Spitzer, ATOPS Integration Manager; (3) LeRC--Gary T. Seng, LeRC Program Manager; Gale R. Sundberg, LeRC Deputy Program Manager; Robert J. Baumbick, LeRC FBL Technical Program Manager; and David D. Renz, LeRC PBW Technical Program Manager; and (4) FAA Technical Center--Peter J. Saraceni, Jr., coordinates certification issues/planning. A preliminary copy of the FBL/PBW plan is included with this invitation to aid you in preparation for participation in the workshop.

The full benefits of full authority digital computer control of transport aircraft have not yet been realized for U. S. aircraft. The intrinsic electromagnetic interference (EMI) immunity of optics technology embodied in FBL can significantly enhance acceptance of full authority digital control by circumventing EMI concerns associated with fly-by-wire, and by providing lifetime immunity to signal EMI. Additionally, FBL has the potential to greatly simplify certification against EMI by enabling technically acceptable bench tests of subsystems. This is opposed to full airplane systems tests, which are required to account for the interaction of electromagnetic threats, such as High Intensity Radiated Fields (HIRF), with wire-based signal transmission media. PBW results in significant weight savings, simplifies maintenance through elimination of hydraulic and pneumatic systems, provides for more efficient engine operation by eliminating the need for engine bleed air, and eliminates the need for the complex variable speed constant frequency drives of present generation secondary power systems.

The goal of the FBL/PBW program is to develop the technology base for confident application of integrated FBL/PBW systems to transport aircraft. LeRC objectives are: to develop optical sensors and electro-optical converters, an integral starter/generator, a power management and distribution system, electrical actuators, and to flight test selected components. LaRC objectives are to demonstrate architecture design and validation appropriate for certification of FBL/PBW systems, develop validated analytical and experimental assessment methodologies for electromagnetic environmental effects, and evaluate end-to-end FBL/PBW systems in ground tests and subsystems in flight tests. LaRC is the coordinating Center.

The objectives of the workshop are to ascertain the FBL/PBW program subelement technical requirements and needs from the industry viewpoint, to provide a forum for presenting and documenting alternative technical approaches (within the scope of the FBL/PBW plan) which satisfy the requirements, and to assess the plan adequacy in accomplishing plan objectives, aims, and technology transfer. The workshop will bring together selected representatives from LaRC, LeRC, FAA, and the aerospace industry including airframe manufacturers and specialized industry technologists.

Five main areas will be addressed in this workshop: (1) optical sensor systems (OSS) including sensors and electro-optic converters; (2) power-by-wire systems (PBW) and components including secondary electrical power management (SEPM), electrical actuators (EA), and electrical engine starters/generators (EESG); (3) designed for validation FBL/PBW fault-tolerant architectures (FTA) based on electronic fault-tolerant computer systems with optical signalling interconnects for vehicle management, flight control, and PBW management; (4) electromagnetic environment (EME) assessment; and (5) system integration and demonstration (SID). Detailed technical requirements such as sensor types and performance accuracies, power bus loads, actuator characteristics, starter/generator performance requirements, data bus and software characteristics, electromagnetic interference assessment approaches, flight test and demonstration needs, and overall system reliabilities are to be gleaned from the workshop.

If you are able to participate in the workshop, it is anticipated that you will be a member of the «comm» committee.

The workshop will consist of an introductory meeting, a "keynote" presentation, a series of individual panel sessions covering the above areas, with midway presentations by the panelists to all the participants, followed by a final summarizing/integrating session by the individual panels, and a closing plenary session summarizing the results of the workshop. A copy of the agenda is enclosed. The agenda will be divided into six periods as follows: an opening half-day plenary period, 2 half-day working periods, a quarter day plenary period, a three-quarter day working period, and a closing plenary period. During the individual panel sessions, attendees will have the opportunity (but no requirement) to stimulate discussion by presenting their perspective and viewpoint, on technical issues only, in an approximately 5- to 7-minute informal presentation to stimulate discussion. Dependent upon the number of attendees desiring to make such presentations, the committee chairperson may elect to limit the number or duration of the individual presentations. A NASA Conference Publication will be published by May 30, 1992, documenting the workshop. The workshop will be unclassified and open to U. S. citizens only.

The co-chairmen of the workshop are:

Mr. Felix L. Pitts  
NASA Langley Research Center  
Mail Stop 130  
Hampton, VA 23665-5225  
Phone: 804-864-6186

Mr. Charles W. Meissner, Jr.  
NASA Langley Research Center  
Mail Stop 130  
Hampton, VA 23665-5225  
Phone: 804-864-6218

A block of rooms has been reserved at the Sheraton Inn Coliseum, 1215 West Mercury Boulevard, Hampton, VA, 23666, Phone: 804-838-5011, Fax: 804-838-7349. A map of the area is enclosed. The hotel rate for the workshop is \$45 plus tax per night. The cut-off date for reservations is February 28, 1992. Reference the "Fly-By-Light/Power-By-Wire/NASA" when making reservations. Transportation will be provided between the Sheraton Inn and the conference location at the H. J. E. Reid Conference Center, LaRC. There will be a registration fee of \$12.50, payable preferably in advance to cover the cost of refreshments during the workshop breaks and snacks during the socials; other functions are "no host." Please make your check payable to the "NASA Langley Conference Center." During the workshop, the message center telephone number will be 804-864-6373.

Please indicate your intention to participate in the workshop to the conference administrative chairperson:

Ms. Lisa F. Peckham  
NASA Langley Research Center  
Mail Stop 130  
Hampton, VA 23665-5225  
Phone: 804-864-6220  
Fax: 804-864-4234

We look forward to seeing you at the workshop.

J. F. Creedon  
Director for Flight Systems

3 Enclosures

## General Letter to Chairpersons

«company»  
 «attention»  
 «street»«if street»  
 «ENDIF»«street2»«IF street2»  
 «ENDIF»«city», «state» «zip»

Dear «fname»:

This letter is to express my appreciation for your participation as chairperson of the «comm» session of the Fly-By-Light/Power-By-Wire (FBL/PBW) Requirements and Technology Workshop. Also, I want to review the general objectives and structuring of the sessions to establish a common framework for all of the sessions.

Probably the most significant challenge of this workshop is dictated by the fact that requirements for all technology areas are interdependent due to the systems context in which they all must function. To accommodate and account for synergistic sensor/architecture/actuator/power requirements, driving factors from each technology perspective must be identified and communicated. Conflicting requirements across technologies must be resolved and a compatible set of requirements derived. This must be accomplished while cost, manufacturability, flight worthiness, and certifiability goals are satisfied. To foster and facilitate communication of the inter-related requirements and issues, midworkshop summary reports are scheduled for the second afternoon of the workshop. In addition to the midterm reports, near real-time summaries of each session discussion for each half-day session will be produced and distributed to all sessions for use in the next half-day session. Finally, discussion and interaction between session chairpersons is necessary, warranted, and encouraged to help accomplish this vital coordination of inter-related requirements. The workshop chairpersons and NASA deputies are listed in enclosure 1.

As was indicated in the workshop invitation, the objectives of the workshop are to determine the technical requirements, to assess the adequacy of the program plan, and to publish a report documenting the results and findings of the workshop by May 30 1992. As indicated in enclosure 2, it is anticipated that each session will:

1. address the technical requirements, needs, and critical issues for the associated technology area
2. determine requirements for technology demonstrations
3. assess the adequacy of the NASA program with respect to objectives, weaknesses, risks, demonstration, and technology transfer
4. determine the critical system requirements, issues and tradeoffs associated with the inter-relationships between all technology areas
5. consolidate, prioritize, and report the findings of the session activities

Appropriate general requirements questions to address should include, but not be limited to:

1. What are the overall FBL/PBW requirements?
2. What are the functional/capability requirements for FBL/PBW demonstration?
3. Are there special requirements or issues that should be identified for this technology area with respect to certification, testing, reliability-maintainability-availability, fault tolerance, environmental requirements, etc.
4. What are the requirements/issues with respect to integration of this technology into FBL/PBW? Carefully consider inter-relations with other technology areas.
5. What are the requirements/issues with respect to certification of FBL/PBW systems?

Enclosure 3 suggests a number of the categories for which requirements must be developed for this program. Due to time considerations, indepth coverage of all requirements categories is not possible for this workshop. However, it is important that critical requirements/issues of the categories which have substantial impact on technology areas be identified. A challenge will be to focus your efforts on only the most important technical requirements/issues in the time available.

Research Triangle Institute (RTI) is providing technical support for this workshop. An RTI technical professional will be assigned to each session to produce session summary reports, produce the final workshop report, and to participate in the session, as appropriate. The RTI representative will contact you prior to the workshop for general coordination.

I look forward to working with you in this workshop. If you have any questions or requests, please call me.

Sincerely,

Felix L. Pitts  
Senior Research Engineer  
System Validation Methods Branch  
Information Systems Division

# SESSION TOPICS AND ACTIVITIES

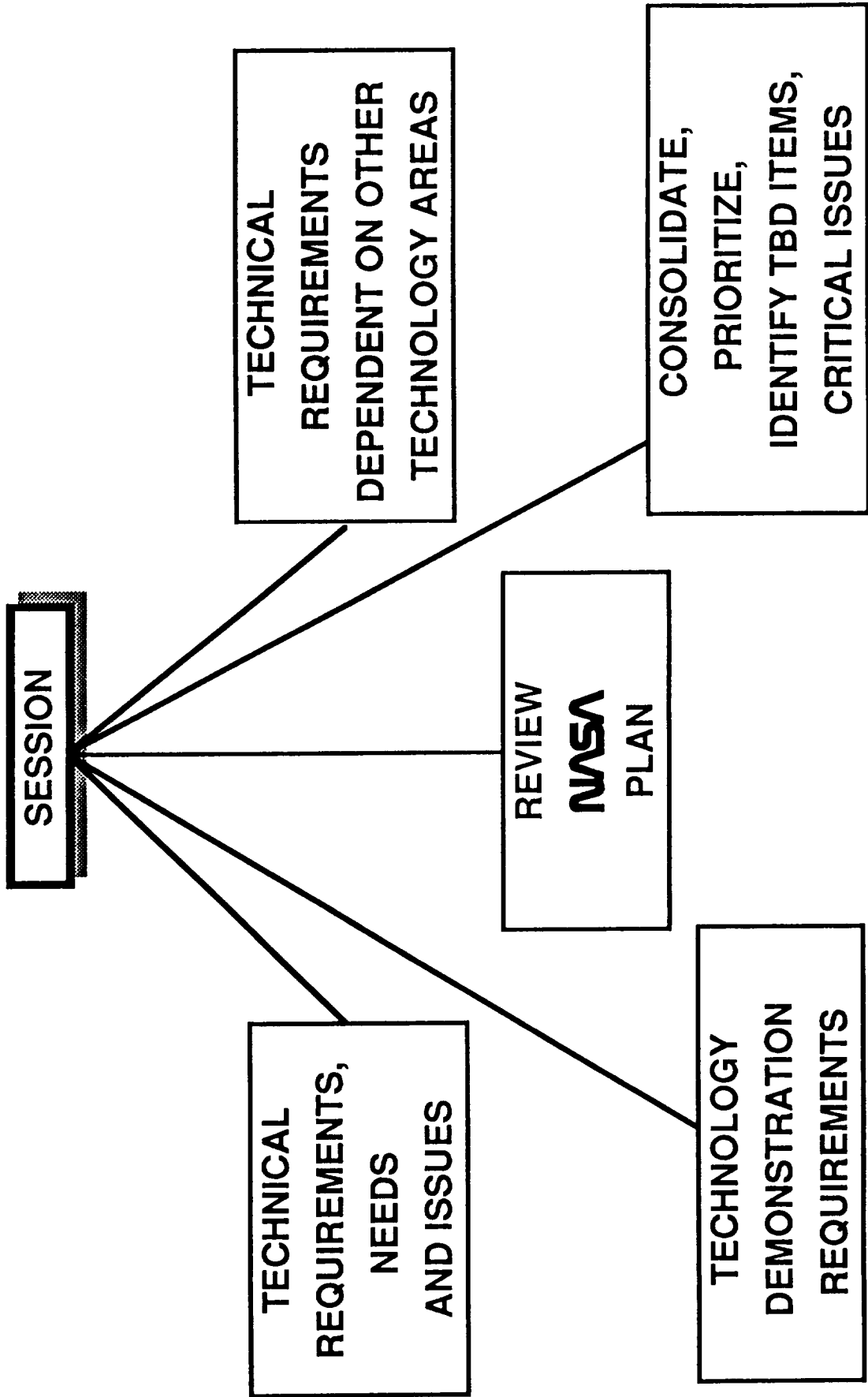

D-9

# REQUIREMENTS CATEGORIES FOR SESSIONS

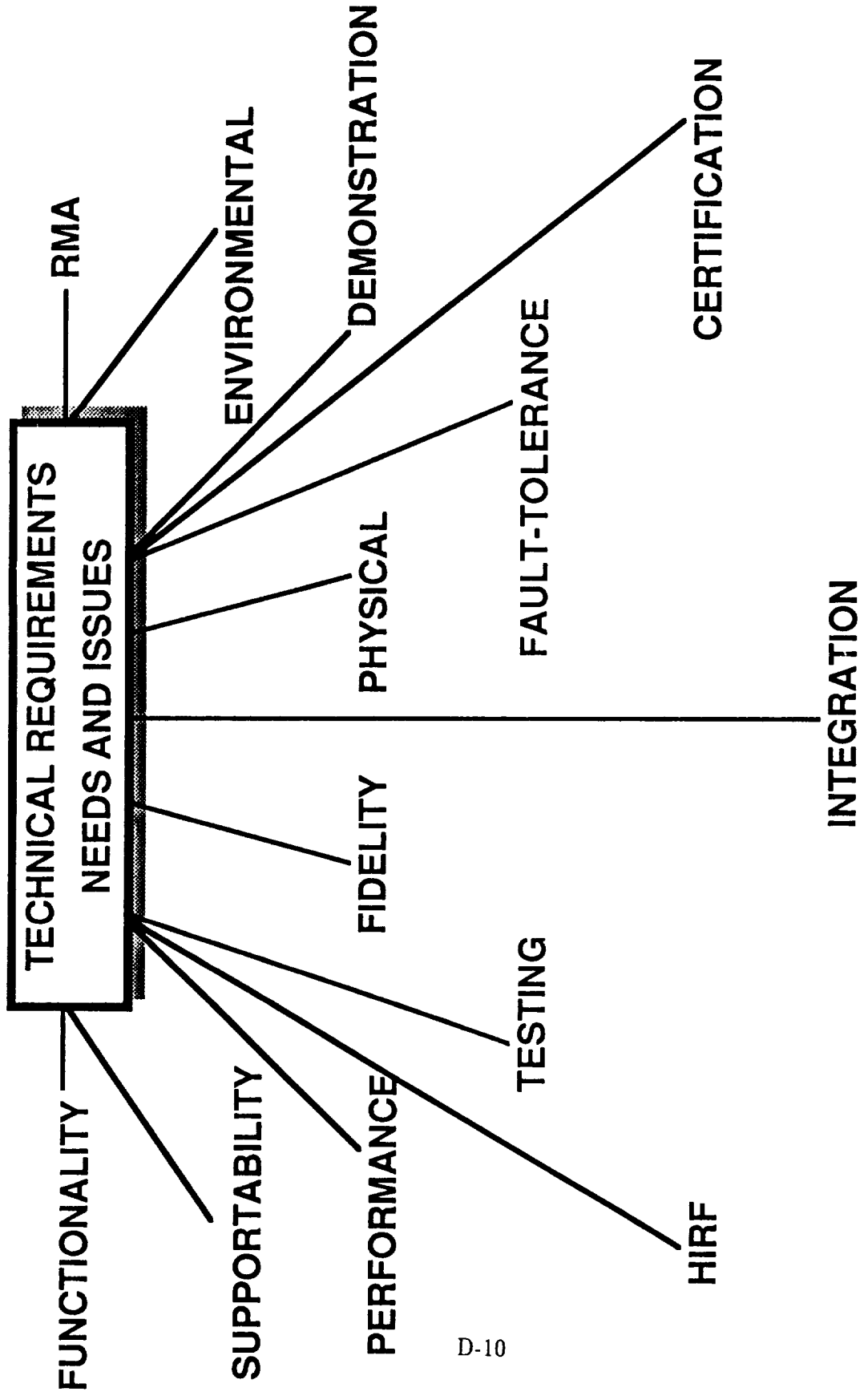

D-10



## Letter to OSS Panel Principles

February 12, 1992

**TO:** Optical Sensor System Session Chairman and Panelists  
**FROM:** Robert Baumbick, NASA Lewis Research Center  
**SUBJECT:** Fly-By-Light/Power-By-Wire (FBL/PBW) Workshop Optical Sensor System Session (OSS) Information and Ground Rules

Presented in this memo is preparatory information for the Optical Sensor System Session (OSS) at the upcoming Fly-by-Light/Power-by-Wire Requirements and Technology Workshop to which you have been invited. The OSS Chairman is Irv Reese of Boeing. The panelists and their respective areas are:

Randall Morton Eldec Corporation (representing sensor vendors)  
Andrew Glista Navair (representing data networks)  
Ed Mitchell Douglas Aircraft (representing airframers)  
Kyoung Chung General Electric Company (representing propulsion)

The panelist's job will be to condense the session content in those areas they represent and aid the chairman in preparing the workshop report and visuals for the plenary sessions.

A tentative session agenda is as follows: an overview of the government program plan will be given by Robert Baumbick of the NASA Lewis Research Center. The session chairman and each panelist will have up to 10 minutes to comment on and ask questions about the government FBL/PBW program, focussed of course on OSS. Following these statements, a brief presentation will be made by the two prime contractors of the FOCSI program. FOCSI serves as a baseline program for the OSS part of the FBL/PBW program. Following this, any attendee who wishes to make a statement on any technical issues pertaining to the OSS part of the program plan itself will have 5 minutes to do so. A discussion on the statement may ensue. The length of discussion on any one issue will be under the control of the chairman. The focus of this workshop session is to be on issues pertaining to the government program and is not intended to present an advantage to any one company. For this reason, the statements made should not contain PR material for any company.

The session objectives are listed below. These objectives will form the guidelines for the session report. Issues are also listed which will lead to answers to the questions posed for the overall session objectives.

#### OVERALL SESSION OBJECTIVES

#### QUESTIONS TO BE ANSWERED AT THE END OF THE WORKSHOP SESSION DEALING WITH OPTICAL SENSOR SYSTEMS.

1. What are the requirements for the OSS portion of this program?

2. If the program, as currently structured, is completed, will the results prove optical sensor system readiness from the technical point of view?
3. Will the results support simpler certification processes?
4. How do we best transition the technology into production systems?
5. What are the priorities for this technology to be transitioned?
6. What key issues (if any) must be worked with the other areas (sessions), especially fault tolerant architecture definition, and power-by-wire?

**SESSION ISSUES FOR DISCUSSION LEADING TO ANSWERS FOR THE  
QUESTIONS ABOVE**

1. Is the chosen testbed (LaRC 737) a reasonable testbed for evaluation of optical sensor system networks? If not, what testbed is recommended?
2. Is the Optical Sensor System program designed properly to prove technology readiness?
3. Should the level of technology in this program consider:
  - fully redundant sensor architecture
  - power by optics (using electrical BOM sensors for position)
  - optical control of power to actuators
  - smart sensor/actuator systems (local loop closure)
  - built in test capability and failure accommodation of sensor systems
4. What are the pros and cons of competing technologies vs. optical sensor systems?
5. Should the program focus on technology readiness for the 1996 timeframe or beyond (year 2005)?

You are encouraged to add other pertinent issues. Constructive criticism will be accepted, as long as the issues pertain to the government program. The agenda is attached. Thank you for your support of the NASA program. If you have any questions regarding this material, please call me at 216/433-3735 or Gary Seng at 216/433-3732.

Robert J. Baumbick  
Engine Sensor Technology Branch

## OPTICAL SENSOR SYSTEM SESSION - AGENDA

Tuesday, March 17, 1992

- 1330 Brief overview of the Optical Sensor System program R. Baumbick
- 1350 Chairman and Panelist's statements
- 1450 FOCSI Briefing by G.E. and M.D. G. Poppel/D. Seal
- 1510 Attendee's statements and discussion by all
- 1645 Adjourn

Wednesday, March 18, 1992

- 0830 Panel session begins - Complete attendee statements and discussions
- 1230 Lunch
- 1330 Plenary Session-OSS midsession summary report Irv Reese, Boeing
- 1400 Other panel's midsession reports
- 1730 Adjourn

Thursday, March 19, 1992

- 0830 Panel session begins - Continue discussions, complete objectives
- 1230 Lunch
- 1330 Plenary Session-OSS final report Irv Reese, Boeing
- 1400 Other session's final reports
- 1700 Adjourn

**NOTE: Break time duration to be established by the Chairman.**

## Letter to PBW Panel Principles

March 3, 1992

McDonnell Douglas Corporation  
Attn: Mr. Louis J. Feiner  
3855 Lakewood Blvd.  
Long Beach, CA 90846-0001

Dear Lou:

First, I would like to thank you for agreeing to help us with the effort of running the workshop by chairing and co-chairing the various PBW panels. Presented in this memo is preparatory information for the PBW Session at the upcoming FBL/PBW Requirements and Technology Workshop. The PBW chairman is Lou Feiner of McDonnell Douglas. The chair and co-chairpersons and government representatives of the PBW panels are:

Lisa McDonald	McDonnell Douglas	SEPM Chair
Barbara Kenny	NASA-LeRC	Government Representative
Ed Beauchamp	Allied-Signal	EA Chair
Jim Mildice	General Dynamics	EA Co-Chair
Mary Ellen Roth	NASA-LeRC	Government Representative
Rick Rudey	Sundstrand	EESG Chair
Tom Jahns	General Electric	EESG Co-Chair
Linda Burrows	NASA-LeRC	Government Representative

The chairperson's job will be to direct the panels to focus on the objectives of the workshop. They will condense the session content for preparing the workshop report and visuals for the plenary sessions.

The Tuesday morning plenary session will include the welcome, FBL/PBW overview, and keynote address by Jim Treacy of the FAA. Starting immediately after lunch with the three PBW panels meeting together, I propose the following agenda:

The PBW chairman, Lou Feiner, will call the PBW session to order and introduce the chair, co-chair and government reps to the group. Then he will introduce a series of speakers who will cover ongoing programs in the PBW area.

First: Gale Sundberg, NASA/LeRC, will give the government overview of the program plan (approx. 20 min.),

Second: Dick Quigley, WRDC, will discuss the Airforce's More-Electric-Aircraft program (approx. 20),

Third: Tom Jahns, General Electric, will discuss the starter/generator effort being done for the Air Force (approx. 20),

Fourth: Lou Feiner, McDonnell Douglas, will discuss the All-Electric, conventional technology study for civil transport aircraft (approx. 20 min.),

Fifth: This time will be set aside for attendees who wish to make a statement on any technical issue pertaining to the PBW part of the program plan itself. This will be limited to 5-7 minutes per speaker. A discussion of the statement may ensue. The length of the discussion will be under the control of the session chairperson. The focus of this workshop session is to be on the issues pertaining to the government program and is not intended to present an advantage to any one company. For this reason, the statements made should not contain PR material for any company. If there are many people who wish to speak, the PBW chairman may elect to give the panels their instructions, then break into the panels where the speakers would give their talks to that panel.

Sixth: Lou Feiner will address the PBW group and give general instructions on what the output of the panels should be.

If time permits, the PBW group will break up into their various panels. If not, they will meet in their panels on Wednesday morning.

The session objectives are listed below. These objectives will form the guidelines for the session report. Issues are also listed which will lead to answers to the questions posed for the overall session objectives.

### OVERALL SESSION OBJECTIVES

#### QUESTIONS TO BE ANSWERED AT THE END OF THE WORKSHOP SESSION DEALING WITH POWER-BY-WIRE.

1. What are the requirements for the PBW portion of this program?
2. If the program, as currently structured, is completed, will the results prove power-by-wire system readiness from the technical point of view?
3. Will the results support simpler certification processes?
4. How do we best transition the technology into production systems? If not, what efforts need to be added to demonstrate tech readiness?
5. What are the priorities for this technology to be transitioned?

6. What key issues (if any) must be worked with the other areas (sessions), especially fault tolerant architecture definition, and fly-by-light?
7. What results are expected from the workshop?
  - measure system application state of readiness
  - measure component state of readiness
  - identify specific system development needed
  - identify specific component development needed
  - identify system integration development needed
  - scope out industry roadmap for all-electric aircraft

**SESSION ISSUES FOR DISCUSSION LEADING TO ANSWERS FOR  
THE QUESTIONS ABOVE**

1. Is the chosen testbed (LaRC 737) a reasonable testbed for evaluation of a power-by-wire system? If not, what testbed is recommended, how many, what locations, etc? What has to be flown to prove flight readiness?
2. Is the PBW program designed properly to prove technology readiness? If not, what changes should be made? What should the technology roadmap be?
3. Should the level of technology in this program consider:
  - fully redundant power system (fault tolerant)
  - built-in test capability
  - smart electrical actuators
4. What are the pros and cons of competing technologies (e.g., high pressure hydraulics) vs. power-by-wire systems?
5. Should the program focus on technology readiness for the 1996 timeframe or beyond (year 2005)?
6. Distributed power and load control vs. centralized architecture
7. PMAD Architecture - Fault Tolerant Avionics architectures



You are encouraged to add other pertinent issues or comments. If you have any questions regarding this material, please call me at 216/433-5321 or Gale Sundberg at 216/433-6152.

David D. Renz  
Electrical Components and Systems Branch

cc: 5430/R. Bercaw  
5430/G. Sundberg  
5430/D. Renz  
5430/L. Burrows  
5430/M. E. Roth  
5430/B. Kenny  
5430/I. Hansen  
5430/Official File



## APPENDIX E: Final Panel Summary Reports

# OPTICAL SENSOR SYSTEMS PANEL FINAL SUMMARY REPORT

Mr. Irv Reese, Boeing Commercial, - Chairperson

Mr. Bob Baumbick, NASA LeRC - Deputy

Mr. Jeff Bartlett, RTI - Coordinator

---

## Optical Sensor Systems (OSS)

- Requirements for OSS
- Credibility Issues for OEM and End Users
- Will Program Prove OSS Readiness?
- Certification Objectives of the Program
- Testbed Requirements for OSS Flight Demo
- Key Issues to be Worked with Other Sessions

## What are Requirements of OSS Portion of Program (OSS)

- Closed loop flight demo of OSS, data communications and systems integration technologies for:
  - Propulsion control
  - Flight control
  - Other aircraft subsystems
- Make OSS technology available by 1996
- Establish credibility with OEM and end user

---

## Requirements for OSS Portion of the Program (OSS)

1. Perform realistic demo of all optical closed loop control for aircraft and engine
2. Make OSS technology available by 1996
3. Establish credibility with OEM and end user
4. Include optical feedback of actuator position
5. Include optical control of actuator drive for electric and hydraulic actuators
  - via digital data bus (smart actuator)
  - via direct analog signal (dumb actuator)

## Requirements for OSS Portion of the Program (Continued) (OSS)

6. Control one axis of airplane using optical technology
7. Control thrust of one engine using optical technology
8. Control/monitor on-engine functions (FADEC loop closure)
9. Address additional optical NAV/guidance sensor(s) as appropriate
10. Address OSS redundancy and failure monitoring
11. Include at least two distinct OSS technologies
12. Demo OSS configuration representative of large aircraft installation
13. Build on lessons from FOCSI, OPMIS and other programs

---

## Credibility Issues for OEM and End User (OSS)

1. Has it been demonstrated in lab/flight?
2. Has it been substantiated by analysis?
3. Does it provide real benefits?
  - Manufacturing cost reduction
  - Signal routing flexibility/fewer paths
  - Direct operating cost reduction
  - Reduced aircraft weight
  - New functional capability
  - Solve existing problems

## Credibility Issues for OEM and End User (Continued) (OSS)

4. Is there a database of in-service test experience? (significant flight hours)
5. Is there a United States competitive advantage?

---

## Will Program (as structured) Prove OSS Readiness (OSS)

- It provides some essential elements
  - Closed loop control
  - Component performance
  - Technology demo
  - Benefit study (recommended)
- It acts as a catalyst to stimulate other needed activities by industry
  - In-service testing
  - Component life testing
  - OSS standardization
  - Reliability, maintainability, manufacturing/installation

## **Certification Objectives of the Program (OSS)**

1. Point to “box” level certification for EMC
2. Familiarize FAA with technology
3. Keep FAA abreast of developments
4. Make FAA aware of issues and solutions
5. Obtain FAA perspectives/input

---

## **Testbed Requirements for OSS Flight Demo (OSS)**

1. For a Realistic Demo:
  - Decouple optical control/feedback from existing system
  - Install key components in representative locations
  - Demo engine and flight control integration
  - Operate representative primary control channels (F/C and engine)
2. Testbed available for significant flight hours
3. Include both feed-back and feed-forward optical paths

**Recommend NASA Do Analysis of Testbed Options to Satisfy These Requirements**



## Key Issues to be Worked with Other Sessions (OSS)

- What are test airplane requirements?
  - Do engine and flight control tests need to be on the same air-frame?
  - OSS integration and standardization worked with FTA and SID
  - EME requirements for OSS (EA environment)
  - Optical technology availability status
-

# ELECTRICAL ACTUATOR PANEL FINAL SUMMARY REPORT

Mr. Edward Beauchamp, Allied Signal, - Chairperson  
 Mr. James Muldice, General Dynamics - Chairperson

Ms. Mary Ellen Roth, NASA LeRC - Deputy

Mr. Ed Withers, RTI - Coordinator

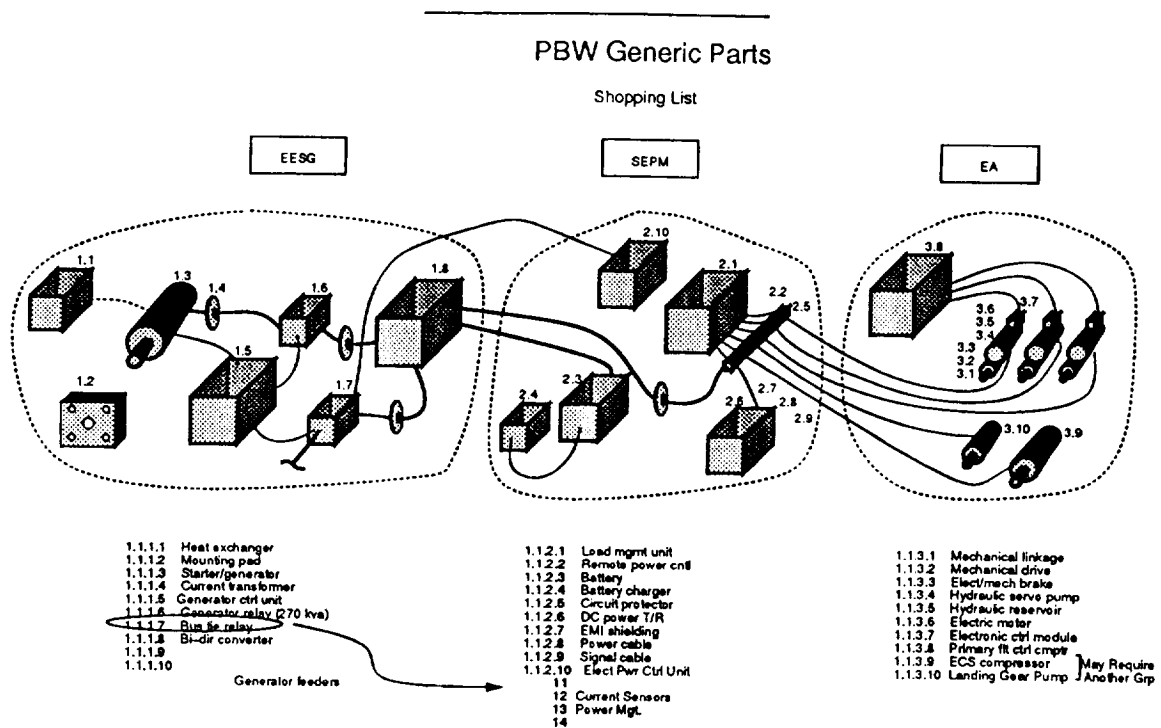

## Issues Related to Other Panels (EA)

- Define power type
- System partitioning

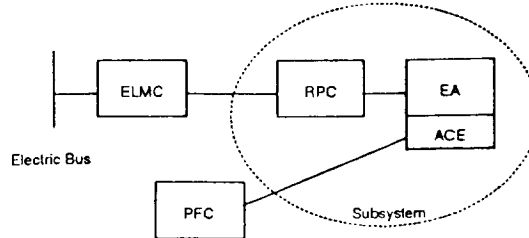

- Redundancy management
  - Control
  - Power
- Regenerative energy
- Type of EA (definition?)
  - Dumb?
  - Smart?

---

## EA Demonstrators (EA)

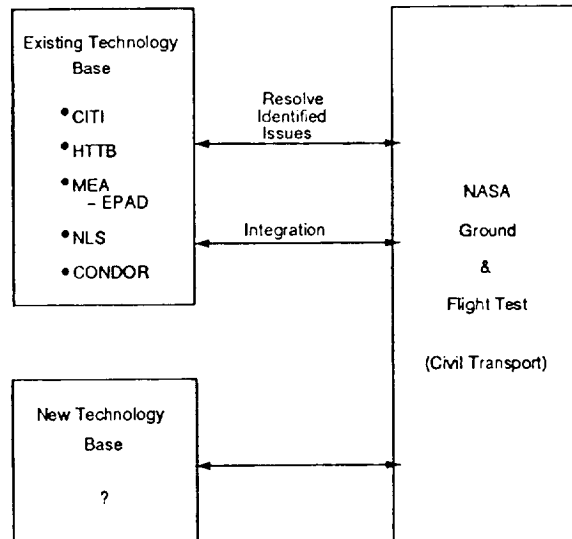

(EA)

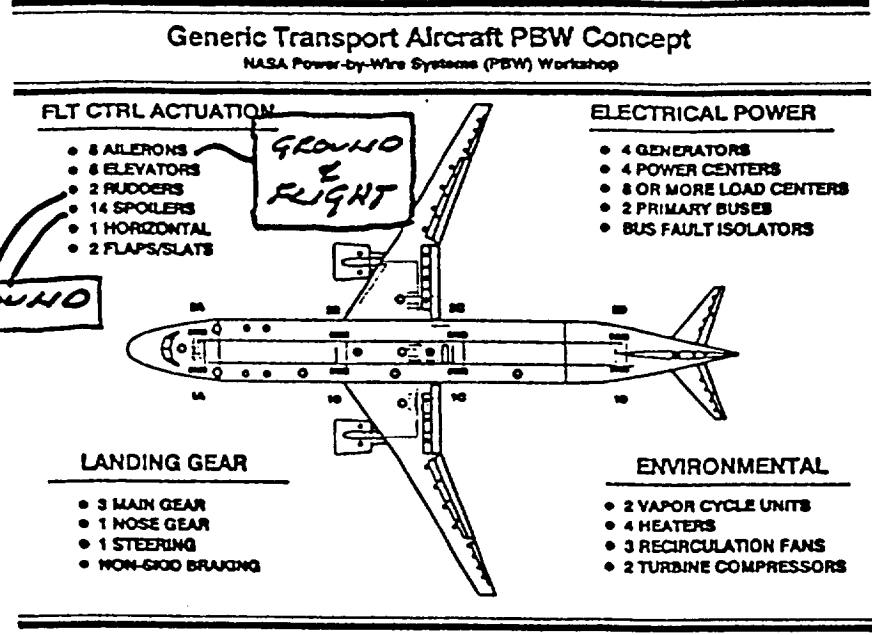

4

(EA)

**Check List for NASA Stated Objectives**  
for PBW Workshop

**Overall**

- 1. PBW program requirements
- 2. Concurrence on PBW program **(AS MODIFIED)**
- 3. Concurrence on certification simplification
- 4. Methods for transfer to production
- 5. Priorities to effect production transition
- 6. Key coordination issues for other work groups

**Specific**

- 1. Measure system application state of readiness
- 2. Measure component state of readiness
- 3. Identify system development needs
- 4. Identify component development needs
- 5. Identify system integration development needs
- 6. Scope out industry roadmap for electric aircraft

**MORE**

**Issues**

- 1. Recommended test bed
- 2. PBW program designed to prove tech readiness **(AS MODIFIED)**
- 3. Technology level, fault tolerance, redundancy, BIT, smart actuators
- 4. Pros/cons PBW competing technologies
- 5. Technology readiness time frame - 1996 or later

## Summary (EA)

- No EA showstoppers
  - EA configuration application specific
  - Application issues identified
  - Interrelated issues identified
    - Recommend inter panel meetings
  - Recommended test/val/cert program method
  - WBS structure changes recommended
-

# SECONDARY ELECTRICAL POWER MANAGEMENT FINAL SUMMARY REPORT

Ms. Lisa McDonald, McDonnell Douglas, - Chairperson

Ms. Barbara Kenny, NASA LeRC - Deputy

Mr. Jorge Montoya, RTI - Coordinator

---

**Circuit and System Protection (SEPM)**  
(Protect circuit wiring and integrity of the system)

Types of Protective Devices

Circuit Breakers  
SSPCs (Solid State Power Controllers)  
Fuses/Current limiters  
Hybrid PCs  
EMPCs (Electromechanical Power Controllers)  
Diodes

## Circuit Protection Issues (SEPM)

- Do solid state devices protect wiring adequately? (arc propagation, high impedance failures, etc.)
- Do conventional devices handle high impedance failures?
- Corona inception
- Load accommodation - pulsed switching loads, inrush fuse clearing
- Regenerative power (switching and circuit protection devices)

---

## Circuit Protection Issues (Continued) (SEPM)

- EXPENSE
- Thermal concerns with solid state and high power devices
- BIT (status, health monitoring)
- Cost reduction
- Standardization
- Autonomous operation
- Cost/benefits (how much protection and intelligence, and how much is it worth?)

## Load Management Devices (SEPM)

- RCCBs (Remote Controlled Circuit Breakers)
- SSPCs (Solid State Power Controllers)
- SSRs (Solid State Relays)
- Smart Relays
- Just Plain Contractors

---

## Load Management Devices Issues (SEPM)

- Architecture (control and power)
- System Design (How do we do it? Unwise not to consider source and load requirements independently; hierarchical and iterative design)
- Redundancy
- Interfaces
- Software (who does it?)
- Control algorithms
- Throughput
- System levels of autonomy
- How do we play with vehicle management
- System integration
- Prioritization of loads for load shedding
- Revisit flight control system specification requirements
- System BIT
- Processing capability (how much?, what type?, where?, speed?, redundancy?)
- Reliability (single point failures)
- Human factors



## Power Conversion Issues (SEPM)

- System design - centralized/localized
- Up conversion (28-270 Vdc)
- Variable Frequency concerns

---

## System Issues (SEPM)

- System architecture (control/power)
- Redundancy - number of redundant components
- Reliability
- Redundancy - channelized vs. modular

## SEPM Priorities (SEPM)

(This is a list of things that need additional work from the panel perspective. Where should the government spend its money)

### Program Elements (PE)

- System architecture definition; what should it include?
  - Number/Types of Power Sources
    - \* Bus configuration
    - \* Degree of automatic control
    - \* Characterize load requirements/power types
    - \* Customer requirements
    - \* Control strategy
    - \* Interfaces w/other systems
    - \* Redundancy
    - \* BIT
    - \* Load management

---

### Priorities (Continued) (SEPM)

#### Components Technology Development Needs

Note: Specific components can't be determined until system study complete, but we anticipate work being required in following areas:

- High current/high voltage SSPCs
- Bidirectional switches
- Power management center
- Power conversion equipment or devices
- Advanced device cooling
- High temperature electronics
- Sensor technology
- Circuit Protection (arc prop, high imped failure)
- Cable/wire and connector development
- Modular switch packaging

## SEPM Priorities (Continued) (SEPM)

### Load Management Related Research

- Packaging
- Architectures
- Interfaces
- Environment (includes EME and thermal)
- Specification work
- Control/data processing
- Redundancy
- System protection
- Imbedded power
- Load shedding, start-up (sequencing)

---

## SEPM Priorities (Continued) (SEPM)

### Test and Demonstration

- Ground
  - Power Quality
  - Power Stability
  - EME (limited-as required)
  - Normal/Abnormal Operation
  - Fault Injection

## SEPM Priorities (Continued) (SEPM)

### Modeling/Simulation

- Reliability
- Functional performance
- Component behavior
- Circuit simulation
- Worst case analysis

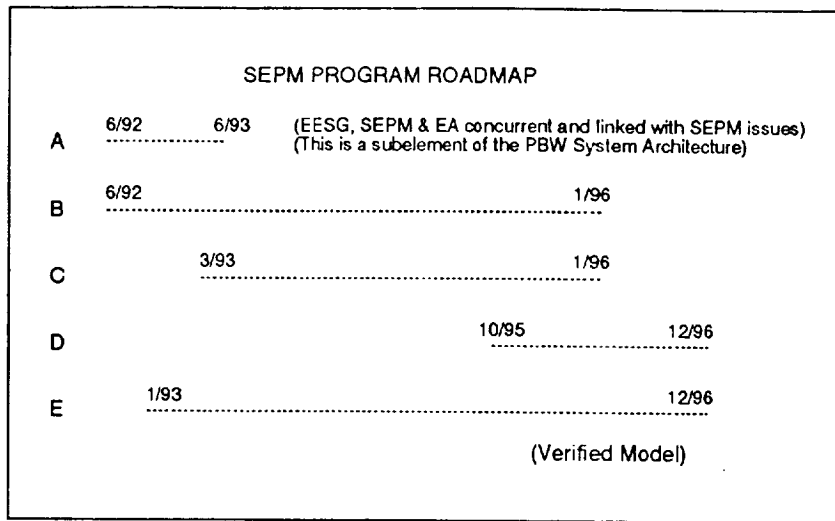

- A) System Architecture Definition
- B) Components Technology Development
- C) Load Management Related Research
- D) Test and Demonstration
- E) Modeling/Simulation

### Flight Test (SEPM)

- Q. Is the LaRC 737 a reasonable testbed?
- A. It is OK from our perspective
- Q. If not, what type testbed is recommended?
- A. Any commercial (prefer) or military transport
- Q. What has to be flown to prove flight readiness?
- A. If technology is new, need to fly at least one power channel. Fly any new technology system components (at least a Load Management Unit)

---

### Power By Wire Issues (SEPM)

- Q. Is the PBW program designed properly to prove technology readiness?
- A. It will not reduce the risks to the point of customer acceptance; it may quantify the risks.
- Q. If not, what changes should be made?
- A. Do more testing and in particular flight testing.
- Q. Should the level of technology in this program consider fully redundant power system.
- A. YES.
- Q. Built-in test capability?
- A. YES, but the extent of BIT is an issue.
- Q. Should the program focus on technology readiness for 1996 or beyond (2005)?
- A. Focus of our evaluation was the 1996 timeframe (See Ground Rule). The program can be extended to include 2005-timeframe, advanced technology issues.

## FBL/PBW (SEPM)

FBL does not improve or reduce (affect) the need for complete EME testing of the PBW system.

---

### Integration Issues (SEPM)

Wire/Cable/Connector Issues: OSS, EME, EESG, FTA, EA

Circuit Protection Issues:

- Load accommodation - pulsed switching loads, inrush - EA
- Regenerative power (switching/circuit protection devices) - EA
- BIT (Status, Health monitoring) - SID
- Standardization
- Autonomous operation - FTA
- Cost/Benefits (how much is it worth?) - SID

Switching

- Degree of Intelligence - EESG, EME, EA
- Interfaces - OSS
- Thermal - SID

## Integration Issues (Continued) (SEPM)

### Load Manager Devices Issues

- Control
    - Algorithms
    - Software
    - Interfaces
    - Architecture
    - Processing
    - Redundancy
  - Power
    - Architecture
    - Quality
    - Redundancy
  - System integration
-

# ELECTRICAL ENGINE STARTERS/GENERATORS PANEL FINAL REPORT

Mr. Rick Rudey, Sundstrand, - Chairperson  
Mr. Thomas Jahns, General Electric, - Chairperson

Mr. Irv Hansen, NASA LeRC - Deputy

Mr. Dave McLin, RTI - Coordinator

---

## Starter/Generator Machine (EESG)

### Objectives

- High reliability/fault tolerance
- High low-speed torque
- High speed (peripheral velocity)
- High power density
- High temperature
- Affordability

### Technology Needs

- Improved thermal management techniques
- No-Lube bearings (APU)
- High-Temperature magnetic materials (e.g., improved processing)
- High-Temperature insulation
- Fault-Tolerant machine configurations
- Improved rotor dynamics



## Technology Readiness Assessment (EESG)

	Present Stage of Development	Technology Readiness % (Note 1)	Months To Prototype (Note 2)	Months To Flight-Worthy Hardware (Note 2)
Main S/G, Ext. Mtd.	Detailed Design	80 %	24	36
Main S/G, Int. Mtd.	Preliminary Design (for Mtl. Engine)	70 %	36 (assumes existing centerline)	48 (assumes existing centerline)
APU S/G, Ext. Mtd.	Analysis & Concept Demo. HW (prelim. design at lower kva)	90 %	24	36
APU S/G, Int. Mtd.	Preliminary Analysis	< 50 %	36	48
Bidirectional Converter	Detail Design w/ Concept Demo HW (bench demo)	80 %	24-36	36-48
Generator Control Unit	Detail design w/ concept demo HW (bench demo)	70 %	24-36	36-48

Note 1: Readiness for NASA program - view from today's perspective

Note 2: Months from now - assuming technology start now.

Also assumes funding availability - projections based on technology assessment

---

### Bidirectional Converter (EESG)

#### Objectives

- High reliability/robustness
- Min. EMI generation/susceptibility
- Location insensitivity
- High power density
- High efficiency
- Affordability

#### Technology Needs

- Improved thermal management techniques
- Hermetic power switch packaging
- Improved passive components (capacitors, inductors)
- EMI tolerance/suppression (e.g., soft-switching converters)
- Self-protection capabilities (robustness)
- Improved sensors (current, voltage)
- Low-weight buswork

## Generator Control Unit (EESG)

### Objectives

- High reliability/fault tolerance
- Strong diagnostics and monitoring
- High bandwidth
- Low EMI susceptibility
- High controller independence
- Affordability

### Technology Needs

- Size and weight reduction (flight-weight packaging)
- Adv. HW/SW architecture for enhance controller fault tolerance
- Improved self-diagnostics and protection features
- Sensor elimination algorithms (position, current, voltage)
- Adv. control algorithms for improved dynamic response (APU)
- Higher computing power (higher-speed DSPs)
- Improved thermal management

---

## System Interaction Issues (EESG)

- Impact of power quality and EMI requirements on component weights
  - Tight requirements on all power distribution (i.e., MIL-STD-704E, -461) can heavily penalize EESG and loads with heavy filtering requirements
  - Separation of utility and control power deserves consideration
  - Issues of component vs. system EMI certification
- Impact of power distrib. architecture on EESG complexity and weight
  - Architectures requiring EESG to develop multiple power types (400Hz, 28 VDC, 270 VDC, ?) add weight penalties to EESG and distrib. network
- Impact of overload requirements
  - Traditional overload requirements of 3 p.u. short circuit current for 5 seconds deserve reconsideration due to EESG weight and size penalties
  - Overload requirements under ground and flight idle conditions also need careful scrutiny to avoid unnecessary EESG weight penalties
- Critical impact of thermal management issues on EESG component locations, sizes, and weights

## EESG Development Program Observations (EESG)

- Engine Starting
    - Engine starting requirements forces introduction of power converter to process generator power and interface machine to system
    - Presence of in-line converter reduces motivation for wild-frequency power distribution
  - Internally-Mounted EESG
    - Preferred ultimate configuration due to PBW system advantages
    - Requires major engine changes with attendant increased costs and risks
      - \* Entails engine redesign to accommodate generator
      - \* Gearbox elimination changes engine accessory configuration
    - Opportunity for NASA cooperation with Air Force/Navy to leverage existing development effort
  - APU
    - Criticality increases for PBW configurations
    - Deserves WBS line-item attention as part of NASA PBW program
-

# **FAULT TOLERANT ARCHITECTURE PANEL FINAL SUMMARY REPORT**

**Mr. Dagfinn Gangsaas, Boeing Defense and Space - Chairman**

**Mr. Dan Palumbo, NASA LaRC - Deputy**

**Ms. Charlotte Scheper, RTI - Coordinator**

---

## **FTA Working Group Summary Program Goal**

**Increase US Competitiveness in Flight Critical System Design and Certification.**

- **Bring FBL/PBW building blocks, architectures and certification technology to maturity by 1996**
- **Provide estimates of quantitative benefits**

## FTA Working Group Summary (FTA) Scope

- Demonstrate one or more flight-critical functions in flight
  - Credibility
  - Challenge
- Help develop industry standards
- Certification
- FBL/PBW system design approach
- Provide ground and airborne test facility
- Human factors

---

## FTA Working Group Summary (FTA)

### Program Inputs

- Define representative target airplanes
- Define FBL/PBW functions and requirements
- Target costs and weight
- Operational environment

# Define PBW/FBL System - Trade Study

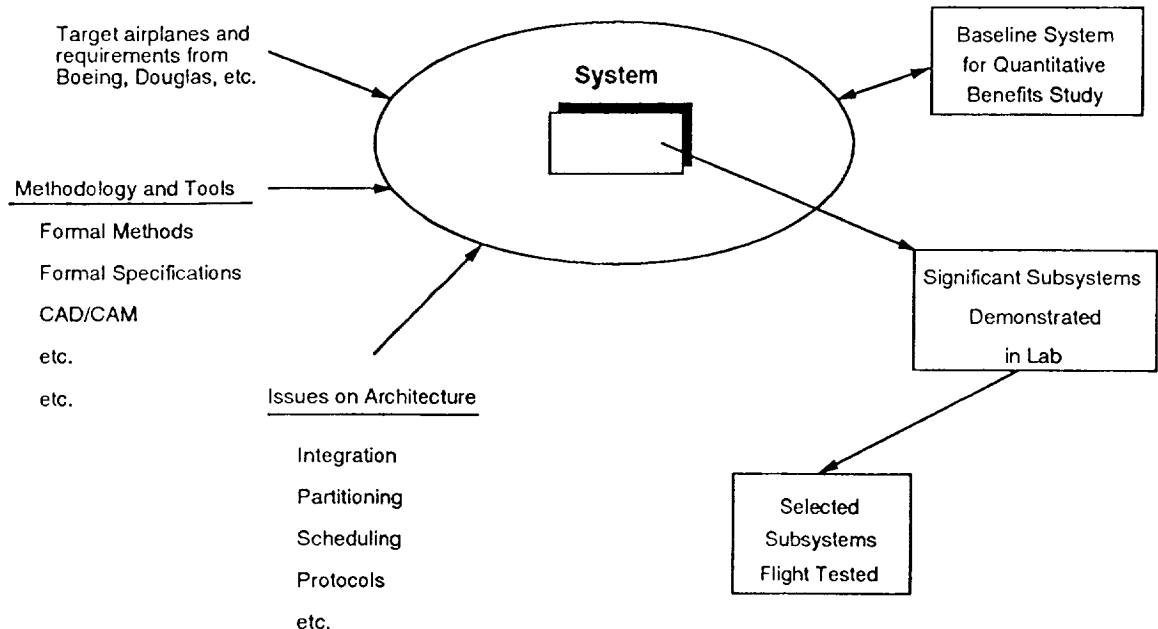

---

## FTA Working Group Summary (FTA)

### Trade Study

- Define preferred architecture(s) and component technologies
- Significant up-front activity
- Ongoing for sanity check

## FTA Working Group Summary (FTA)

### Power-By-Wire Issues

- Electrical power generation and distribution becomes flight critical
- New failure modes and effects
- Integration - cultural resistance
- Possible additional EMI source

### Power-By-Wire Challenge

- Definition of architecture for PBW
  - Level of redundancy
  - Redundancy management
- Integration with FBL

---

## FTA Working Group Summary (FTA)

### Fly-By-Light Issues

- Same Issues as for FBW
- FBL architecture will be different than FBW
  - Weight trades
  - Bandwidth
  - Failure modes
  - Transmission losses (taps/connectors)
  - Photonic component characteristics
  - Active/passive component placement
  - Noise immunity/electrical isolation
  - Point-to-point vs. data bus

## FTA Working Group Summary (FTA)

### FBL Challenges

- Definition of FBL architecture
  - Exploit FBL strengths
  - Avoid FBL weaknesses
  - Integration vs. fault containment
  - Integration vs. timing
  - Integration with PBW

---

### FTA Working Group Summary (FTA)

#### FBL Challenges (continued)

- Data distribution networks
  - $10^{-9}$  reliability
  - Standards
    - \* Protocol
    - \* Topology
  - Fault tolerance
  - Cost
- Photonic sensors and interfaces
  - What kind(s)
  - Standards
  - Cost



## FTA Working Group Summary (FTA)

- Certification issues
    - How to certify?
    - FAA part of program from beginning?
  - Develop overall certification approach
  - Identify and avoid uncertifiable technologies or design approaches
-

# ELECTROMAGNETIC ENVIRONMENT PANEL FINAL SUMMARY REPORT

Mr. Richard Hess, Honeywell Air Transport Systems - Chairperson

Mr. Felix Pitts, NASA LaRC - Deputy

Mr. Aubrey Cross, RTI - Coordinator

---

## Highly Reliable Fly-By-Light/Power-By-Wire Systems Technology (EME)

**Goal:** Develop the technology base for confident application of integrated FBL/PBW systems to transport aircraft

**Objectives:**

- Develop and flight test optical sensors and electro-optical converters
- Develop and ground test a power management and distribution system and flight test an electrical actuator
- Demonstrate architecture design and validation appropriate for certification of FBL/PBW systems
- Develop validated analytical and experimental assessment methodologies for electromagnetic environment effects
- Demonstrate end-to-end FBL/PBW systems in ground tests and partial flight test

## Workshop Objective (EME)

- Determine technical requirements
- Assess plan adequacy
  - Objectives
  - Technology transfer
- Prepare technical report 6/92

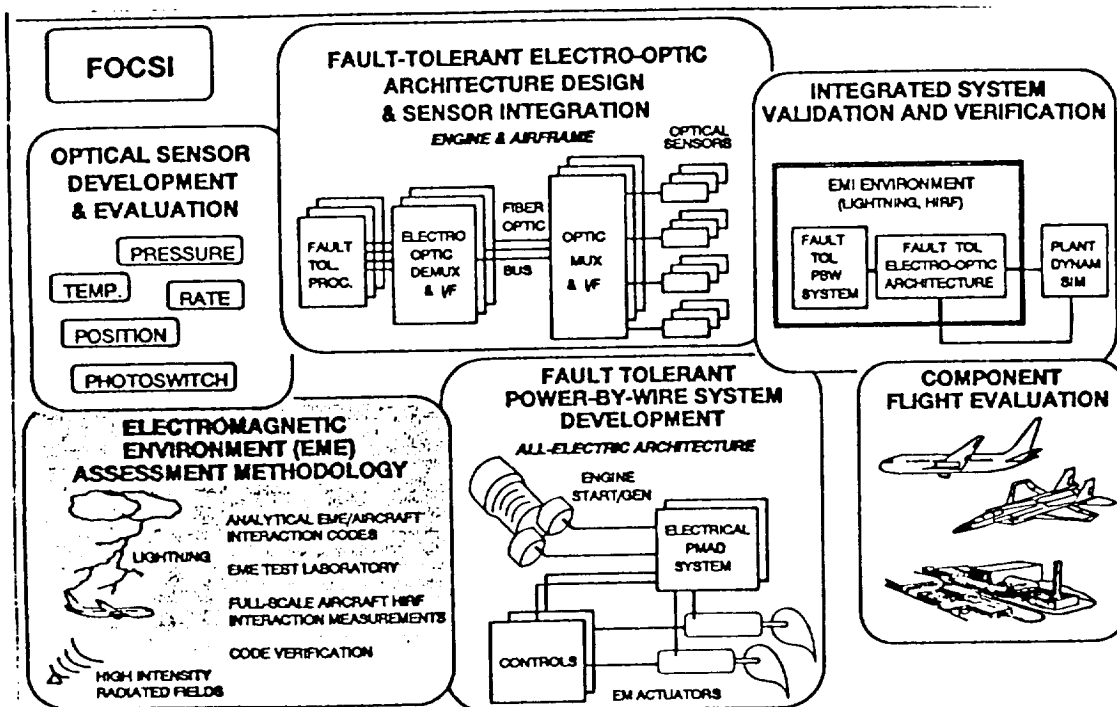

## Session Topics and Activities (EME)

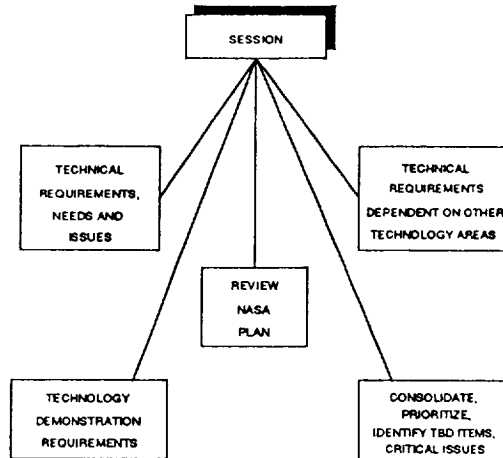

---

### NASA Plan Review (EME) 5.0 EME Assessment Technology

- Goals and objectives are realistic
- Schedule is supportable
- Proposed host aircraft (ATOPS 737) ideal

## EME Analytic Assessment Methodology (EME)

- Three dimensional FDTD preferred methodology
- Evolution/development
  - Extending technical capability (priority 1)
  - User friendly (priority 2)

---

### Comparison of Computational Capability for a Small Aircraft (EME)

Parameter	80486	Cray II	MAXIM
$\Delta s$ (spatial resolution)	.25m	.07m	.07m
$\Delta t$ (temporal resolution)	.45 ns	.13 ns	.13 ns
Bandwidth	240 MHz	850 MHz	850 MHz
Memory Reg.	21 MB	235 MWords	940 MB
CPU Time/ $\Delta t$	42 sec.	5.9 sec.	1.5 sec
Total CPU (10 periods)	26 hrs.	12.5 hrs.	3.2 hrs

Small Aircraft  
15m Length and Wing Span

### Comparison of Computational Capability for a Large Aircraft (EME)

Parameter	80486	Cray II	MAXIM
$\Delta s$ (spatial resolution)	1m	.28m	.28m
$\Delta t$ (temporal resolution)	1.8 ns	.52 ns	.26 ns
Bandwidth	60 MHz	212 MHz	212 MHz
Memory Reg.	21 MB	235 MWords	940 MB
CPU Time/ $\Delta t$	42 sec.	5.9 sec.	1.5 sec
Total CPU (10 periods)	26 hrs.	12.5 hrs.	3.2 hrs

Large Aircraft  
60m Length and Wing Span

---

### Comparison of Computational Capability for a Medium Aircraft(EME)

Parameter	80486	Cray II	MAXIM
$\Delta s$ (spatial resolution)	.5m	.14m	.14m
$\Delta t$ (temporal resolution)	9 ns	.26 ns	.26 ns
Bandwidth	120 MHz	425 MHz	425 MHz
Memory Reg.	21 MB	235 MWords	940 MB
CPU Time/ $\Delta t$	42 sec.	5.9 sec.	1.5 sec
Total CPU (10 periods)	26 hrs.	12.5 hrs.	3.2 hrs

Medium Aircraft  
30m Length and Wing Span

## Extending Technical Capability (EME)

- Full frequency range coverage (Priority 1)
- Statistical processes (Priority 2)
- Dispersive media (Priority 3)
- Composite material properties (Priority 4)
- Thin slot/wire formalism (Priority 5)
- Multiconductor (includes single conductor case) cable networks (Priority 6)
- Other

---

## EME Validation Demonstration (EME)

- Lab test
  - Laboratory facilities
  - Frequency range issues
  - Benchmark test methods
  - Alternate test methods (including an integrated lightning/HIRF/EMI approach and circuit susceptibility margins)
  - Analytic support

## EME Validation Demonstration (EME)

- Aircraft test (code validation)
  - On ground (support of fly-by)
    - \* Low level swept coupling
    - \* Low level swept fields
    - \* Full level at frequencies of emitter chosen for fly-by
  - Fly-By
    - \* VOA (priority 1)
    - \* VOR (priority 2)
    - \* Wallops (priority 3)
    - \* Identification of pass/fail criteria

---

## SID Considerations (EME)

- Hardening to EME effects is a system architectural issue
- Physiological/health effects relative to potential fields
- Identify/provide a list of existing EM tools and guidelines for other groups
- EME assessment technology panel proceeded on the basis that spurious light sources, such as lightning, will not be a FBL threat



## Summary (EME)

- Tasks have been identified, consolidated, and prioritized
  - There are no TBD items
  - EME assessment technology
    - Identified as a high priority aerospace community need in the previous workshop
    - Is critical to taking EME effects into account during concept definition and tradeoffs
-

# SYSTEM INTEGRATION AND DEMONSTRATION PANEL FINAL SUMMARY REPORT

Mr. John Todd, McDonnell Douglas, - Chairperson

Mr. Cary Spitzer, NASA LaRC - Deputy

Dr. Bob Baker, RTI - Coordinator

---

## SID Recommendations (SID)

- The research architecture must be flexible to allow insertion of new/alternate technology while producing credible results and enabling incremental technology transfer
  - Open architecture
  - FBL
  - PBW
  - Hybrid
- Identify and evaluate existing alternate ground and flight testbeds to facilitate enabling technology transfer in a timely manner
  - Subsystem
  - Integrated system

## SID Recommendations (Continued) (SID)

- Prioritize design criteria
- Analysis and comparison of competing architecture
- Define architecture
  - Study
  - Ground
  - Flight
- Define design requirements
  - Interface
  - Functional
  - Environmental

---

## Recommendations for Testing Locations (SID)

- Components - suppliers
- Subsystems - airframers, major subs, Government facilities
- System and integration - NASA
- Reliability testing - all

## System Attributes (SID)

	Ground	Aircraft
Concept Architecture	AIRLAB Architecture	ATOPS Architecture
Overall System Distributed Fault Tolerant	Substantial-All Key Technologies Integration, and Testing	Limited-Correlation of Ground to Aircraft Installations
	Operational Test R, M&S, EME	

---

### Ground Testing and Evaluation (SID)

#### What we absolutely must do

- Thermal management
- Certificability
- RM&S
- Actuator/control
- Integration (end-to-end closed loop)
- Degraded operations
- Fault tolerance
- Flight-critical validation of controls and power
- EME/HIRF modeling/testing
- Validate experimental data and analysis system/approach correlation of ground and flight system and test/data gatherings
- Critical actuation

## Ground Testing and Evaluation (SID)

### What needs to be done

- Power on demand capability
- Flight-critical demonstration?
- Extend and integrate FBL into other critical systems
- Production manufacturer
- RM&S

---

## Aircraft Testing and Evaluation (SID)

What We Absolutely Must Do	What Needs to be Done
Actively controlled optical fan speed sensor	Representative capacity power generator (engine mounted)
End to end fiber optic control	Representative
Demonstrate regenerative power accommodation	Fault Tolerant PMAD
Demonstrate installation and maintenance concepts	
Demonstrate power switching accommodation	
Aircraft EME internal model correlation and validation	
Representative optically controlled power switching	
Operational Transparency	
Representative Engine starter / generator	



## **APPENDIX F: Attendee Position Statements and Recommendations - Documenting Correspondence**

Letter - John McGough, Allied-Signal Aerospace

Letter - Franklin Banks, Banks Engineering and Labs

Letter - Carlos Bedoya, McDonnell Douglas

**Letter - John McGough, Allied-Signal Aerospace**



Bendix Flight Systems Division  
Teterboro, New Jersey 07608-1173  
Telephone (201) 288-2000

March 25, 1992

Felix Pitts  
NASA Langley Research Center  
Mail Stop 130  
Hampton, VA 23665

Dear Felix:

This correspondence summarizes Bendix Guidance & Control Systems' (BGCS') views on NASA's fault-tolerant architecture study. It is BGCS' belief that the goals of the study should be to configure a high speed data bus system that accommodates and supports:

- the survivability and cost goals of the next commercial airplane,
- subsystem performance requirements (e.g., bandwidth and data latency),
- subsystem fault-tolerance, monitoring and redundancy management requirements,
- integrated control between subsystems,
- physical or functional migration if required by subsystems,
- synchronous and asynchronous control (each subsystem would make its own choice),
- interchannel data transfers without the necessity of providing separate busses.

Eventually the bus system would become an ARINC standard, accepted by the entire industry.

Integration of critical functions is best performed by the subsystem designer with V&V the responsibility of each subsystem designer to the extent required to validate the subsystem. Total system integration and test would be the responsibility of the end user.

Yours truly,

Approved:

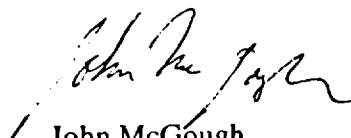

John McGough  
Sr. Principal Engineer

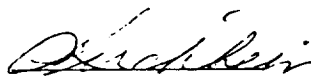

A. Kirchhein  
Manager, Flight Controls

P.S. I have no objection to your sending this note to the other members of the FTA committee, if you so desire.

**Letter - Franklin Banks, Banks Engineering and Labs**

11404 Sorrento Vly Rd. Ste 114 San Diego CA 92121  
TEL. (619) 452-1080 FAX (619) 452-6965

3/27/92

NASA Langley Research Center  
Mail Stop 130  
Hampton VA 23665

Attention Felix Pits

Subject: Fly-By-Light

Having recently attended the AF National Planning Activity for More Electric Aircraft Technology and NASA Fly by Light/Power by Wire Conferences, I have some suggestions which may already be in place.

1) I suggest Fly by Light development is most efficiently perused as to cost, time and assurance of final results thru a team effort. Such a team should consist of an Airframe Manufacturer, an Engine Manufacturer an Avionics Manufacturer, a Servoactuator Manufacturer, a Switch Manufacturer and Selected Sensor Manufacturers. The programs could start with two competing teams with competing concepts. The technology could be totally or partially merged early-on. The hardware costs of such a program are relatively small compared to the cost of the overall team effort. The team effort is essential to assure producible, usable systems as a final product. I have issued unsolicited proposals to form such a team thru the use of a "letter of engineering cooperation".

2) Fly by Light is a separate issue from the electric power system and should be administered separately. Fly by Light technology runs across the discipline of all airplane systems including but not limited to: Flight Controls, Electric Systems, Environmental Systems, Power Systems, Fuel Systems etc.. Weight and performance advantages exist in all areas.

3) The Fly by Light and Power by Wire technology has been described as revolutionary. I suggest a third revolution is in place which is "total computer control". Many new control and sensor wires or fibers will be required. All three technologies are complementary.

4) Fly by light must have a competitive advantage over the European commercial and the US military fly by wire systems. This is accomplished by multiplexing and use of simple interfaces. I wonder if the full consequences of long term maintenance of wire shielding is understood. I hear hints that long term heroic efforts may be required to circumvent a creeping latent safety problem due to shielding decay?

11404 Sorrento Vly Rd. Ste 114 San Diego CA 92121  
TBL.(619)452-1080 FAX (619)452-6965

BANKS  
banks engineering & labs

3/27/92

Subject: Fly-By-Light

5) The technology for military and commercial airplanes is essentially common, therefore programing should provide for complementary rather than parallel development. This can be accomplished by dividing development by function or to clearly develop competitive technology. One or not more than two overall airplane strategies should be evolved. A unified approach is essential for time and cost constraints. A well directed effort can produce systems suitable for commitment to production within three years.

6) My proposed comprehensive airplane system strategy uses a Standardized Optical IC for interface with the optical MUX local station and a second Standardized Optical IC for interface with "command and sensing modules". These ICs use state of the art components including emitters, wavelength multiplexers, BANKS modulators and BANKS optical switches. Multiple sensors, as in a flight control actuators, use frequency multiplexing and multiple commands use wavelength multiplexing. It is estimated that by customizing emitters and filters eight or more commands and a dozen or more sensors can be accommodated on a single fiber at a local station or controller. Funding of breadboard systems will quickly demonstrate the viability of flight test brassboards.

This approach is also compatible with interfacing advanced detectors as they evolve.

very truly yours,

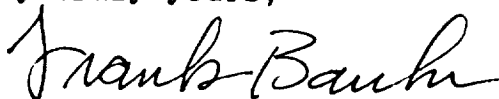

Franklin J. Banks

Letter - Carlos Bedoya, McDonnell Douglas

# **MCDONNELL DOUGLAS**

*McDonnell Aircraft Company*

3 August 1992

To: NASA Langley Research Center  
Attn: Felix Pitts  
Mail Stop 130  
Hampton, VA 23665-5225

Subject: Comments by McDonnell Aircraft Company on NASA's Power-by-Wire/  
Fly-by-Light Program Electromagnetic Environment (EME) Assessment  
Technology Task

Dear Felix,

In response to your request for comments on the current NASA plan for development of EME assessment in support of the NASA power-by-wire/fly-by-light program the following comments are provided.

The goal of NASA's EME Assessment task should be the transfer and infusion of existing military and commercial technologies into a standardized, acceptable process that can be used by airframe manufacturers in the FAA certification process. The program should address all of the facets of the electromagnetic environment which include not only the direct and indirect effects of lightning, but also the effects of high intensity radiated field (HIRF). In order for the program to be acceptable, the FAA should be a key player in establishing the program. The aircraft certification requirements as established by both the SAE-AE4R and AE4L committees and adopted by the FAA should be used as guidelines for formulation of the EME program.

The NASA program should address the direct lightning effects by investigating the technique called "rolling sphere". This technique has been stated by AE4L committee as one of the ways of identifying the lightning attachment points of an aircraft. However, the exact methodology for doing this has not been established. The EME Program can develop an FAA approved methodology by which aircraft manufacturers can establish the probabilities of lightning attachment for any given point on the aircraft. These probabilities would be used to determine the degree of lightning protection needed for each part of the aircraft surface.

For the indirect effects of lightning, the EME program should develop standardized, FAA approved analysis techniques with the capability of accounting for composite skins and/or substructures. Many techniques for determining the induced voltages and currents on aircraft wiring have been used in the past. These techniques must always be coupled with extensive lightning tests. If a standardized and FAA approved methodology could be established, the aircraft lightning protection design would be more effective (limiting over-design) and more efficient (less weight).

F-8

In the area of HIRF analysis, the EME program should be based on past efforts in electromagnetic pulse (EMP), high power microwave (HPM) and radar cross-sectional scattering (RCS) analyses. The HIRF field-to-wire analysis must account for frequencies from 10 Kiloherzt to 40 Gigahertz. The analysis technique is frequency dependent; therefore, what works well at gigahertz range may not work at low frequencies. The EME HIRF analysis program should begin by reviewing the various coupling analysis techniques available for other types of electromagnetic environmental threats. Analysis techniques would then be selected for the various frequency ranges based on the computer code's efficiency and accuracy.

In conclusion, the NASA EME Assessment Program should be structured to give a complete and comprehensive analyses of the electromagnetic environment threat as seen by aircraft, whether the aircraft is military or commercial, large transport or small passenger. By having a comprehensive analysis, the aircraft design can be optimized to minimize weight, space and cost by integrating the various protection schemes into a unified EME protection design.

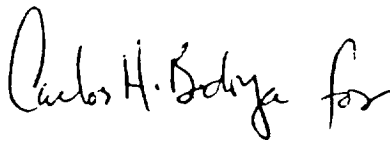

Jerry W. McCormack  
Electronic Systems Technology  
Electromagnetic Environmental Effects

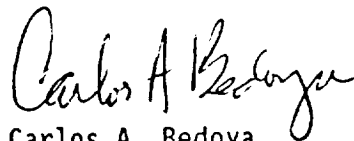

Carlos A. Bedoya  
New Aircraft Products Division  
Advanced Integrated Controls

CB:cg  
1618C.CB







REPORT DOCUMENTATION PAGE			Form Approved OMB No. 0704-0188	
Public reporting burden for this collection of information is estimated to average 1 hour per response, including the time for reviewing instructions, searching existing data sources, gathering and maintaining the data needed, and completing and reviewing the collection of information. Send comments regarding this burden estimate or any other aspect of this collection of information, including suggestions for reducing this burden, to Washington Headquarters Services, Directorate for Information Operations and Reports, 1215 Jefferson Davis Highway, Suite 1204, Arlington, VA 22202-4302, and to the Office of Management and Budget, Paperwork Reduction Project (0704-0188), Washington, DC 20503.				
1. AGENCY USE ONLY (Leave blank)	2. REPORT DATE September 1992	3. REPORT TYPE AND DATES COVERED Conference Publication		
4. TITLE AND SUBTITLE Fly-By-Light/Power-By-Wire Requirements and Technology Workshop		5. FUNDING NUMBERS WU 505-64-10-09		
6. AUTHOR(S) Robert L. Baker and Felix L. Pitts, Editors				
7. PERFORMING ORGANIZATION NAME(S) AND ADDRESS(ES) NASA Langley Research Center Hampton, VA 23681-0001 and Research Triangle Institute Center for Digital Systems Research P. O. Box 12194 Research Triangle Park, NC 27709		8. PERFORMING ORGANIZATION REPORT NUMBER		
9. SPONSORING / MONITORING AGENCY NAME(S) AND ADDRESS(ES) National Aeronautics and Space Administration Langley Research Center Hampton, VA 23681-0001		10. SPONSORING / MONITORING AGENCY REPORT NUMBER NASA CP-10108		
11. SUPPLEMENTARY NOTES Langley Task Monitor/Conference Chairman: Felix L. Pitts Baker: Research Triangle Institute, Research Triangle Park, NC; Pitts: Langley Research Center, Hampton, VA. Report prepared by Research Triangle Institute under NASA contract NAS1-19214, Task 13.				
12a. DISTRIBUTION / AVAILABILITY STATEMENT  Subject Category 05, 33, 74		12b. DISTRIBUTION CODE		
13. ABSTRACT (Maximum 200 words)  This report, prepared by Research Triangle Institute, documents the results of the Fly-By-Light/Power-By-Wire (FBL/PBW) Workshop held on March 17-19, 1992, at the NASA Langley Research Center, Hampton, VA. The FBL/PBW program is a joint NASA LeRC/LaRC effort to develop the technology base for confident application of integrated FBL/PBW systems to transport aircraft. The objectives of the workshop were to ascertain the FBL/PBW program technical requirements and needs from the industry viewpoint, provide a forum for presenting and documenting alternative technical approaches which satisfy the requirements, and assess the plan adequacy in accomplishing plan objectives, aims, and technology transfer. Areas addressed were: optical sensor systems, power-by-wire systems, FBL/PBW fault-tolerant architectures, electromagnetic environment assessment, and system integration and demonstration. The workshop consisted of an introductory meeting, a "keynote" presentation, a series of individual panel sessions covering the above areas, with midway presentations by the panel chairpersons, followed by a final summarizing/integrating session by the individual panels, and a closing plenary session summarizing the results of the workshop. The workshop was unclassified and was open to U.S. citizens only. The workshop was attended by approximately 160 personnel.				
14. SUBJECT TERMS Fly-By-Light/Power-By-Wire; optical sensor systems; power-by-wire; fault-tolerant architectures; electromagnetic environment assessment; system integration and demonstration		15. NUMBER OF PAGES 283		16. PRICE CODE
17. SECURITY CLASSIFICATION OF REPORT Unclassified	18. SECURITY CLASSIFICATION OF THIS PAGE Unclassified	19. SECURITY CLASSIFICATION OF ABSTRACT	20. LIMITATION OF ABSTRACT	