

NASA Contractor Report 4447

P-107

Advanced Composites Structural Concepts and Materials Technologies for Primary Aircraft Structures

Design / Manufacturing Concept Assessment

Robert L. Chu, T. D. Bayha,
H. Davis, J. E. Ingram,
and J. G. Shukla

CONTRACT NAS1-18888
SEPTEMBER 1992

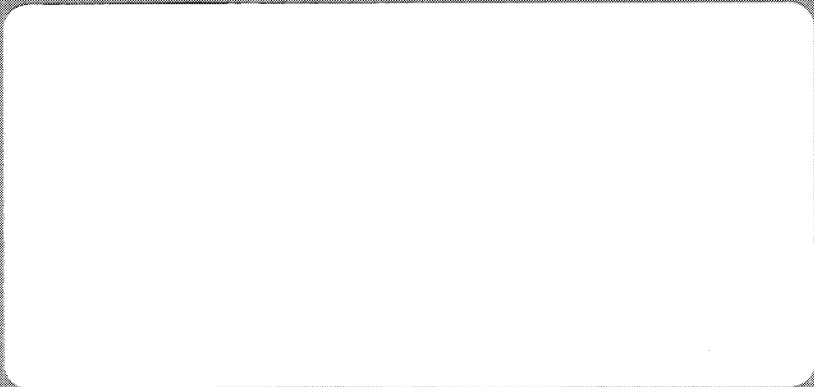

(NASA-CR-4447) ADVANCED COMPOSITES
STRUCTURAL CONCEPTS AND MATERIALS
TECHNOLOGIES FOR PRIMARY AIRCRAFT
STRUCTURES: DESIGN/MANUFACTURING
CONCEPT ASSESSMENT Final Technical
Report, May 1989 - May 1992
(Lockheed Aeronautical Systems Co.) H1/05 0022685
107 p

N95-10316
Unclass

NASA Contractor Report 4447

Advanced Composites Structural Concepts and Materials Technologies for Primary Aircraft Structures

Design / Manufacturing Concept Assessment

Robert L. Chu, T. D. Bayha,
H. Davis, J. E. Ingram,
and J. G. Shukla
*Lockheed Aeronautical Systems Company
Marietta, Georgia*

Prepared for
Langley Research Center
under Contract NAS1-18888



National Aeronautics and
Space Administration

Office of Management

Scientific and Technical
Information Program

1992

FOREWORD

This final technical report covers the work performed under Phase I, Evaluation and Initial Development, Task 1 Design/Manufacturing Concept Assessment, of NASA Contract NAS1-18888, entitled, "Advanced Composite Structural Concepts and Materials Technology for Primary Aircraft Structures", between May 1989 to May 1992. This contract is administered under the management direction of Dr. John G. Davis and under the technical direction of Dr. Randall C. Davis, NASA/SPO, NASA Langley Research Center, Hampton, Virginia 23665.

Lockheed Aeronautical Systems Company (LASC) is the prime contractor. Mr. A. C. Jackson is the LASC Program Manager, directing all the contract activities. Mr. Ron Barrie of Advanced Structures and Materials Division was the technical thrust leader in the performance of this task.

Other key LASC contributors to the Trade Study Task are listed below:

Preliminary Design Trade Studies

Robert L Chu

Jay Shukla

Hu Davis

Structural Concept Development

Robert L Chu

Tom Bayha

Table of Contents

Foreword.....	iii
List of Figures.....	vii
List of Tables.....	ix
Abbreviations.....	xi
Summary.....	xiii
1.0 Introduction.....	1
2.0 Preliminary Design Trade Studies.....	4
2.1 Baseline Wing And Fuselage.....	4
2.2 Design Studies of Wing Concepts.....	4
2.2.1 Modular Wing.....	11
2.2.2 Resin Transfer Molded Wing.....	20
2.2.3 Automatic Tow Placed Wing.....	25
2.2.4 Braided Wing.....	29
2.3 Design Studies Fuselage Concepts.....	31
2.3.1 Sandwich Fuselage.....	38
2.3.2 Geodesic Fuselage.....	45
2.3.3 Stiffened Shell Fuselage.....	49
2.4 Cost Trade Studies.....	52
2.4.1 Cost Estimating Rules and Methodology.....	52
2.4.2 Cost Comparisons & Contributors.....	54
2.4.2.1 Wing Design/Manufacturing Concepts.....	54
2.4.2.2 Material Cost Sensitivity Study.....	59
2.4.2.3 Wing Spar Trade Study.....	60
2.4.2.4 Fuselage Design/Manufacturing Concepts.....	60
2.5 Weight Trade Studies.....	69
2.5.1 Weight Estimating Assumptions.....	69

2.5.2	Weight Drivers.....	71
2.5.3	Weight Comparison.....	72
2.6	Supportability Trade Study.....	74
2.6.1	Rationale.....	74
2.7	Trade Study Results.....	74
2.7.1	Wing Results.....	77
2.7.2	Fuselage Results.....	79
3.0	Structural Concept Development.....	81
3.1	Wing Structures.....	82
3.1.1	Joints.....	82
3.1.2	Cutouts.....	82
3.1.3	Taper Effects.....	86
3.1.4	Test Plan - Wing Structures.....	86
3.2	Fuselage Structures.....	89
3.2.1	Test Plan - Fuselage Structures.....	91

List of Figures

Figure 1	ACT Program Master Schedule.....	2
Figure 2	L-1011 Baseline Wing Structure.....	5
Figure 3	L-1011 Baseline Fuselage Structure.....	6
Figure 4	PASCO Condition 3 Blade Stiffened Panels (with rib weights).....	13
Figure 5	PASCO Condition 3 'J' Stiffened Panels (with rib weights).....	13
Figure 6	Optimized Upper Cover Cross Section for Modular Wing Box Concept.....	15
Figure 7	Modular Wing Concept.....	16
Figure 8	Embedded Stiffener Configuration For Modular Wing Concept.....	16
Figure 9	Co-Cured Rib Caps/Shear-Ties.....	17
Figure 10	Spars And Rib Web Configuration.....	18
Figure 11	Spar Tooling Approach.....	20
Figure 12	Upper Cover with Integral Spar Cap.....	21
Figure 13	RTM Wing Concept Stiffener Configuration.....	22
Figure 14	Lower Cover With Integral Spar Cap/Web.....	23
Figure 15	Integrally Stiffened Thermoplastic Rib Web.....	24
Figure 16	Automatic Tow Placed Wing Concept.....	26
Figure 17	ATP Wing Concept Details.....	27
Figure 18	"U" Channel Build-up and Stuffer Insertion.....	28
Figure 19	Braided Wing Concept.....	30
Figure 20	Revised Braided Concept.....	31
Figure 21	Corrugated Sandwich Panel Sizing Results.....	34
Figure 22	Geodesic Panel Geometry And Design Variables.....	35
Figure 23	Geodesic Panel Finite Element Model Geometry.....	36
Figure 24	Geodesic Panel Buckled Mode Shape.....	36
Figure 25	Stiffened Shell Fuselage Stiffener Configuration.....	38
Figure 26	Sandwich Fuselage Concept.....	40
Figure 27	Core Element With Integral Flange.....	40
Figure 28	Schematic Of Tube With Filler At Corners.....	41
Figure 29	Female Tooling Concept.....	42
Figure 30	Male Tooling Concept.....	42
Figure 31	"F" Frame Configuration.....	43
Figure 32	Proposed Fuselage Splice.....	44
Figure 33	Geodesic Fuselage Concept.....	45
Figure 34	Stiffener Build-up With Filcoat Material, (Two Plies Shown).....	47
Figure 35	Intersection Point Covers.....	48
Figure 36	Fabrication Sequence.....	49
Figure 37	Stiffened Shell Fuselage Concept.....	50
Figure 38	Cross-Section Of The Tooling For Infusing The "J" Preform With Resin.....	51
Figure 39	Final Assembly Sequence.....	53
Figure 40	L-1011 Wing Box.....	55
Figure 41	Modular Wing.....	56
Figure 42	RTM Wing Box.....	57
Figure 43	Tow Placement Wing Box.....	58
Figure 44	Modular Wing Design Concept Composite Material Cost Study.....	61

Figure 45	ATP Wing Design Concept Composite Material Cost Study.....	62
Figure 46	RTM Wing Design Concept Composite Material Cost Study.....	63
Figure 47	L-1011 Baseline Cost Distribution.....	65
Figure 48	Sandwich Fuselage Cost Distribution.....	66
Figure 49	Geodesic Fuselage Cost Distribution.....	67
Figure 50	Stiffened Shell Fuselage Cost Distribution.....	68
Figure 51	Wing Box Upper And Lower Surface Weight Variation.....	70
Figure 52	Wing Weights Comparison.....	73
Figure 53	Fuselage Weights Comparison.....	73
Figure 54	ATP Wing Concept Details.....	79
Figure 55	Stiffened Shell Fuselage Concept.....	80
Figure 56	Cutout Concept #1.....	83
Figure 57	Cutout Concept #2.....	84
Figure 58	Cutout Concept #3.....	84
Figure 59	Cutout Concept #4.....	85
Figure 61	Cutout Concept #5.....	85
Figure 62	Splice Concepts.....	91
Figure 63	Stringer/Frame Intersection.....	92

List of Tables

Table 1	L-1011 Wing Box Design Criteria At OSW 151.10.....	9
Table 2	Preliminary Sizing Parametric Analysis Matrix.....	9
Table 3	Areal Weight Summary, Covers, Conditions 1 & 2.....	12
Table 4	Areal Weight Summary, Covers, Condition 3.....	12
Table 5	Areal Weight Summary, Covers And Ribs, Conditions 1 & 2.....	14
Table 6	Areal Weight Summary, Covers And Ribs, Condition 3.....	14
Table 7	Material Selection And Fabrication Method For Modular Wing Concept.....	19
Table 8	Material Selection And Fabrication Method For RTM Wing Concept.....	25
Table 9	Material Selection And Fabrication Method For ATP Wing Concept.....	29
Table 10	Design Loads Without Internal Pressure for L-1011 Fuselage at FS 750.0.....	32
Table 11	Design Loads With Internal Pressure for L-1011 Fuselage at FS 750.0.....	33
Table 12	Material Selection And Fabrication Method For Sandwich Fuselage Concept.....	44
Table 13	Material Selection And Fabrication Method For Geodesic Fuselage Concept.....	50
Table 14	Material Selection And Fabrication Method For Stiffened Shell Concept.....	53
Table 15	Rib Concept Cost Comparison.....	59
Table 16	Cost Analysis Report.....	64
Table 17	Wing Weights Comparison.....	71
Table 18	Fuselage Weights Comparison.....	71
Table 19	Maintainability Evaluation Rationale.....	75
Table 20	Inspectability Evaluation Rationale.....	75
Table 21	Durability Evaluation Rationale.....	76
Table 22	"Ilities" Trade Study Results.....	78
Table 23	Wing Trade Study Results & Final Ranking.....	77
Table 24	Fuselage Trade Study Results & Final Ranking.....	80
Table 25	Comparison of Cutout Concepts.....	87
Table 26	Task 1 Wing Structure Test Matrix.....	88
Table 27	Task 1 Fuselage Structure Test Matrix.....	94

Abbreviations and Symbols

ACT	=	Advanced Composite Technology
ATL	=	Automatic Tape Laying
ATP	=	Automatic Tow Placement
D/M I	=	Design/Manufacturing Integration
E_1	=	Longitudinal modulus of elasticity, Msi
E_2	=	Longitudinal modulus of elasticity, Msi
E_{1-t}	=	Longitudinal tensile modulus of fiber, Msi
E_{1-c}	=	Longitudinal compressive modulus of fiber, Msi
FS	=	Fuselage station
G_{12}	=	Inplane shear modulus, Msi
Gr/Ep	=	Graphite/Epoxy
G_t	=	Shear Modulus through the thickness, Msi
N_x	=	Load (x-direction), lb
N_{xy}	=	Load (shear), lb
OWS	=	Outer wing station
P_a	=	Applied load, lb/in
P_{cr}	=	Critical load, lb/in
PMI	=	Polymethacrylimide
q_a	=	Applied distributed load, lb/in
q_{cr}	=	Critical distributed load, lb/in
RFI	=	Resin Film Infusion
RTM	=	Resin Transfer Molding
SOW	=	Statement of Work
t_{ply}	=	ply thickness
W_d	=	Weight or cost of design
W_f	=	Weighing factor
W_g	=	Weight or cost goal

Greek

α	=	Stiffener angle (geodesic panel), degrees
ϵ_t	=	Tensile strain, $\mu\text{in/in}$
ϵ_c	=	Compressive strain, $\mu\text{in/in}$
γ_{12}	=	Shear strain, $\mu\text{in/in}$
ν	=	Poisson's ratio

Summary

This final report covers work performed on Phase I, task 1 of the Advanced Composites Structural Concepts and Materials Technologies for Primary Structures contract which is part of the NASA-ACT program. The focus of this task was to develop advanced composite wing and fuselage concepts using emerging technologies in order to reduce overall costs.

In subtask 1, "Initial Assessment/Ranking", four wing and three fuselage design/manufacturing concepts were developed that had the potential to meet the program cost and weight goals. The wing concepts are labeled: modular; resin transfer molded; automatic tow placed and braided. The fuselage concepts are labeled: sandwich; geodesic and stiffened shell. Through the development process it was determined that braiding of an entire wing structure was not practical with current or near term braiding equipment and was therefore dropped from further consideration. The remaining wing and fuselage concepts were developed in sufficient detail to provide cost and weight data. Design details such as, cutouts, taper effects and joints were not addressed in this subtask, but were to be addressed in subtask 2, "Structural Concept Development". Trade studies were conducted to compare the cost and weight of each concept to the baseline data. As part of the trade studies, each concept was evaluated by experts in the various fields to provide a subjective analysis to assist in the down selection process. Trade study results were used to select which concept to carry forward into the detail design subtask. Therefore, the automatic tow placed wing and the stiffened shell fuselage concepts were taken into the detail design subtask for further development.

Early during the detail design subtask, the NASA Steering Committee recommended that the ACT programs focus in resin transfer molding, automated fiber placement and textiles structures. Therefore, subtask 2 was terminated and Lockheed efforts were redirected to textile structures development.

1.0 Introduction

The use of graphite/epoxy for conventional medium primary and secondary structures has been demonstrated to save weight compared to conventional metal structures and to meet all the strength, stiffness and durability requirements of transport aircraft in commercial airline service. This is also true for military transport aircraft. However, the full potential of these composite materials has not yet been realized, primarily because cost savings have not been demonstrated in conjunction with efficient structural concepts.

The Advanced Composite Technology (ACT) Program was initiated to provide creative research on new and innovative structural concepts, in particular concepts for wing and fuselage primary structures, to achieve this potential for future transcentury aircraft. The new structural concepts are to take advantage of improved organic matrix materials and new and emerging fabrication techniques. The validated structures technology being developed under the ACT program is necessary to provide the confidence essential for the use of composite materials for future primary aircraft structures.

The Lockheed contract consists of two phases. Phase I, Evaluation and Initial Development, was initiated in May, 1989 and ran through May of 1992. Phase II, Development and Verification of Technology, was initiated in October 1991 and is scheduled to run through April 1995. The total program extends over 72 months.

Phase I consisted of five tasks: Task 1, Design/Manufacturing Concept Assessment; Task 2, Structural Response and Failure Analysis; Task 3, Advanced Material Concepts; Task 4, Assessment Review; and Task 5, Composite Transport Wing Technology Development.

Phase II consists of four tasks: Task 1, Advanced Resin Systems for Textile Technology; Task 2, Preform Development and Processing; Task 3, Design, Analysis, Fabrication and Test; and Task 4, Low-Cost Fabrication Development. The program master schedule is shown in Figure 1.

Phase I has been completed and Final Reports are published for Tasks 1, 2 and 3. Task 4 was an assessment of Phase I results and the plans for

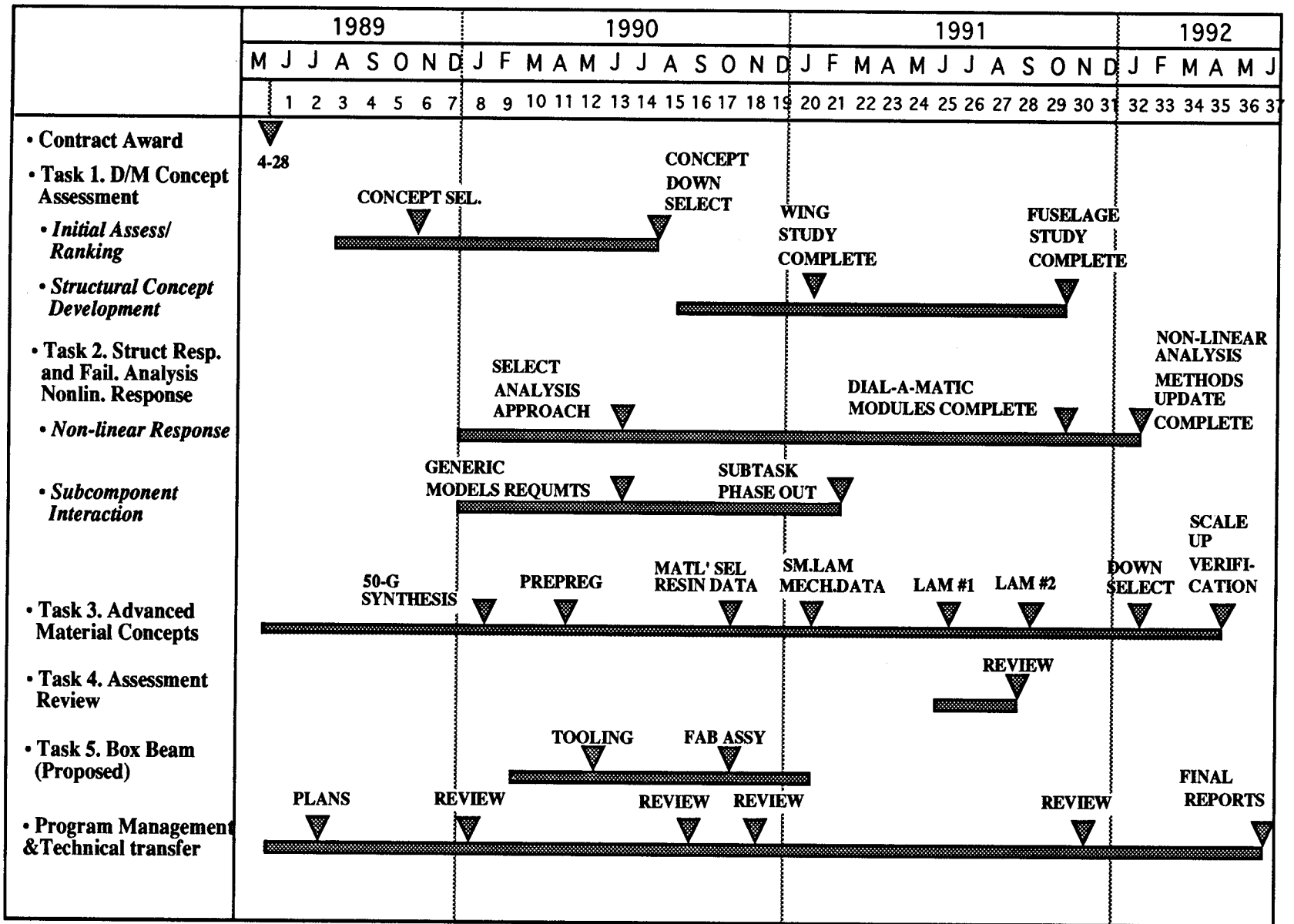

2

Phase II. Task 5 has no Final Report. The results were published in papers presented at the First and Second ACT Conferences (References 1 and 2).

Throughout this program, technical information gathered during the performance of the contract is being disseminated throughout the aircraft industry and to the government. This information is being distributed through monthly technical reports and final task reports. Oral reviews have been conducted to acquaint the aircraft industry and government with progress on the program.

Use of commercial products or names of manufacturers in this report does not constitute official endorsement of such products or manufacturers, either expressed or implied by the National Aeronautics and Space Administration.

2.0 Preliminary Design Trade Studies

2.1 Baseline Wing And Fuselage

The baseline aircraft selected for this study was the Lockheed Tristar L-1011 commercial transport aircraft. This baseline was selected because of the extensive loads, cost and weights data available. The L-1011 is a modern design representing current aluminum design technology and manufacturing methodology.

Baseline Wing

The L-1011 baseline wing design, shown in Figure 2, is a swept and tapered wing approximately 1000 inches long. The upper surface skin has a splice and "Z" section spanwise stiffeners. The lower surface is continuous with "J" section stiffeners. Typical rib spacing is 26 inches. All components are mechanically joined by conventional methods to form the wing assembly. Loads and design criteria were taken from OWS 151.10 and are discussed in detail in Section 2.2.

Baseline Fuselage

The L-1011 baseline fuselage is shown in Figure 3 and composed of stiffened skins, circumferential frames and passenger cabin floor structure. For this study, the cabin floor structure was omitted. Efforts were focused on the development of the fuselage shell structure with loads and design criteria taken from FS 750.00, these are discussed in detail in Section 2.3.

2.2 Design Studies Of Wing Concepts

In the subtask of Task 1, "Initial Assessment/Ranking", several wing design concepts were developed using emerging technologies in an attempt to achieve the program goals. These were, resin transfer molding (RTM) of large assemblies, modular, automated tow placement (ATP) and braiding. Within each concept different structural options, such as, different stiffener configurations, integral or separate spars, were evaluated before arriving at the final configurations. These will be

LOCKHEED L-1011 TRISTAR WING

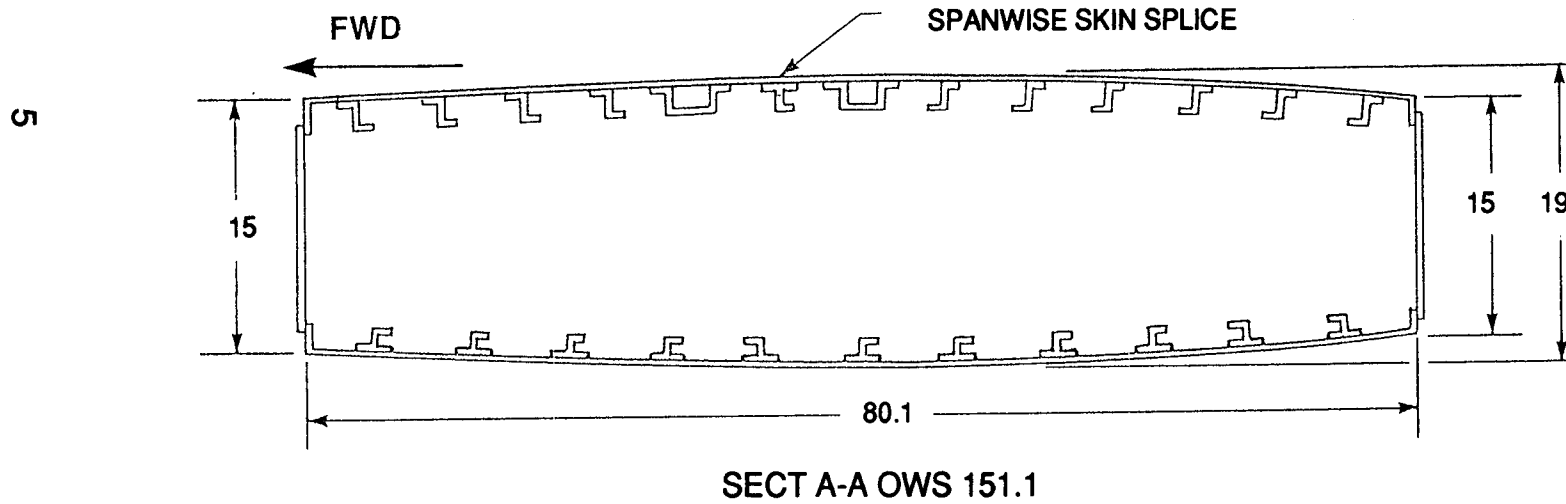
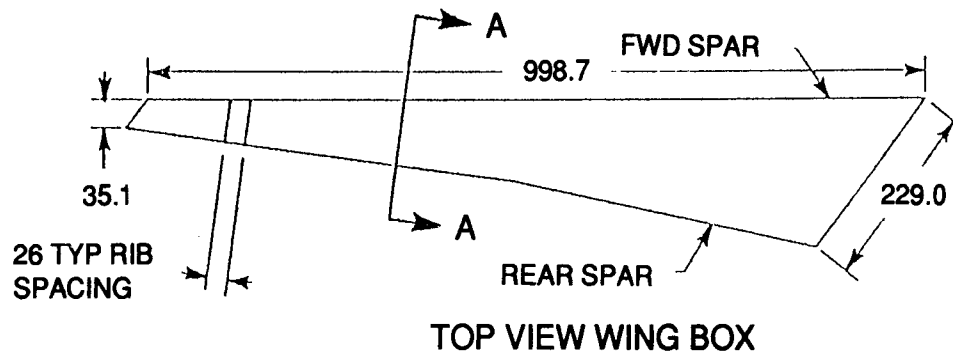

Figure 2, L-1011 Baseline Wing

LOCKHEED L-1011 TRISTAR FUSELAGE

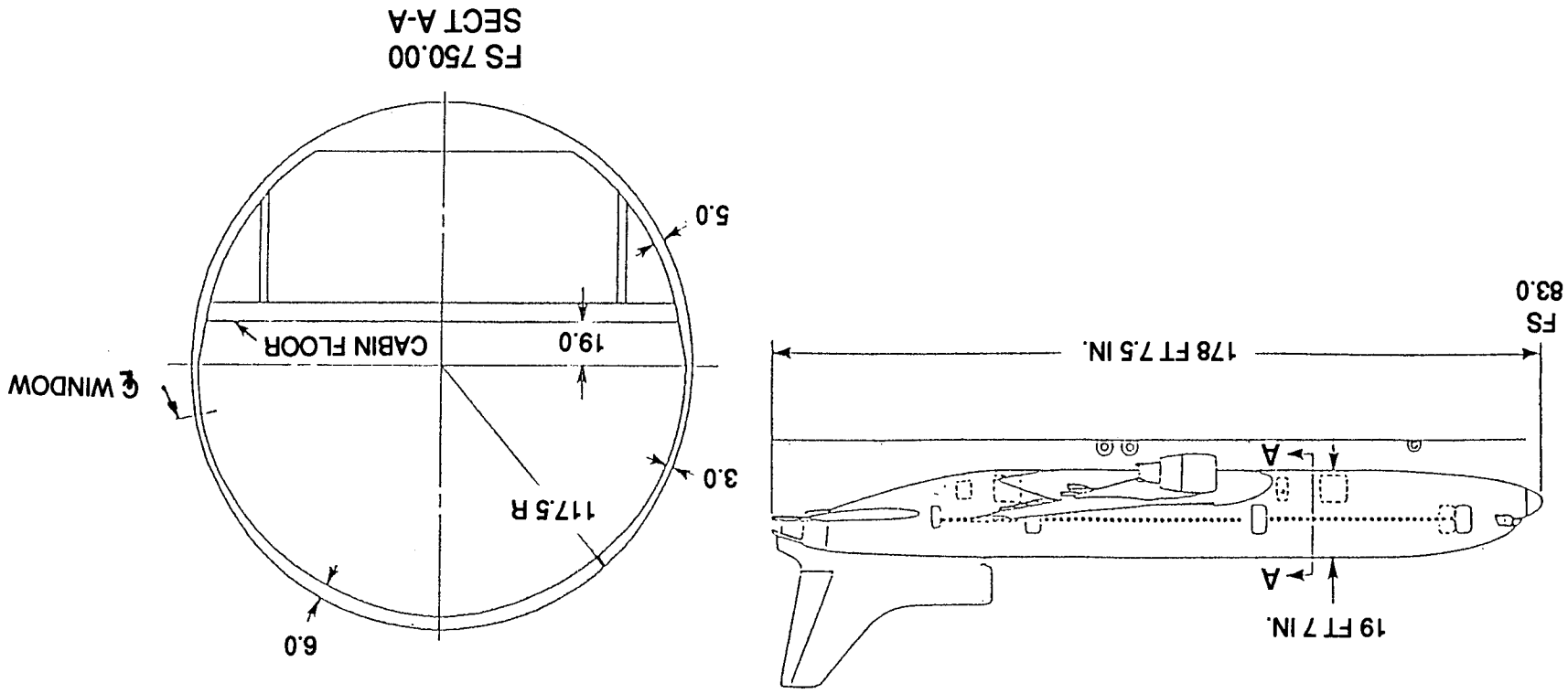

Figure 3, L-1011 Baseline Fuselage

discussed under each concept below. The concepts were developed in enough detail to perform cost and weight analyses, but omitted design details such as, joints, cutouts and taper effects. Although these items may be major cost and weight drivers they were omitted from the "Initial Assessment/Ranking" subtask, but were addressed later in the Structural Concept Development subtask, see Section 3.0. All of the concepts were developed to a similar level of detail to provide for a meaningful comparison. The wing concepts are labeled ATP, Braided, Modular and RTM, representing the basic manufacturing approach for that concept, although the Modular concept was not restricted to any one particular manufacturing approach.

In developing the concepts no restrictions were placed on the choice of material/material form, process or structural arrangement. The designs started with the "blank sheet" approach. Both thermoset and thermoplastic materials were acceptable and all material forms were considered for the various applications. However, the cost issue generally drove the materials selection away from thermoplastics and toward thermosets. Emphasis was placed on automated and/or out-of-autoclave processes to reduce hand labor and manufacturing costs. Tooling requirements were considered but the emphasis was on reducing recurring costs, with tooling costs being amortized over a production run.

The concepts were developed using the Design/Manufacturing Integration (D/M I) team approach. In order to develop the designs in a timely and efficient manner all engineering disciplines (design, stress, manufacturing, producibility, materials and processes, and quality) were involved early in the design cycle, and throughout the design phase actually drove the concepts to their final design configurations. Each engineering discipline provided inputs into the designs to ensure that they were viable, producible and supportable.

The D/M I team developed design packages that consisted of concept drawings, a material selection list, a manufacturing plan and a quality assurance plan. Completed design packages were then submitted to cost and weights for analysis. Estimated costs and weights were then compared to the baseline cost and weights to determine which concept best satisfied the program goals, see Section 2.7.

Wing Stress Analysis

A Structural Sizing Trade Study was conducted to support the evaluation of four composite wing box concepts. The sizing effort involved determining, for each concept, the optimum (minimum weight) dimensions of the wing covers, ribs and spars so that a weight comparison could be made on the basis of an entire wing box cross section.

The four wing box concepts considered in the trade study are:

- I. Filament wound with integral blade stiffeners.
- II. Resin Transfer Molded with integral stiffeners.
- III. Modular design consisting of an automated fiber placement skin, stiffened by co-bonded pultruded blade stiffeners, filament wound spars and press formed ribs.
- IV. Braided with integral "Hat" stiffeners.

The design criteria for sizing each of the wing concepts is summarized in the Table 1. The design loads shown are upper cover loads taken from the L-1011 wing box analysis. Specifically, the internal loads used were at outer wing station (OWS) 151.0 and result from a 1.33 g aileron roll condition.

The optimum cover cross section was determined by conducting a parametric study in which the three stiffener cross sections were analyzed with varying stiffener spacing, rib spacing and skin laminate types. The parametric analyses are summarized in Table 2. For each stiffener type and spacing considered, an optimum set of detail dimensions for the the flange widths and thicknesses was calculated using the PASCO program.

PASCO is a NASA developed program for analysis of stiffened panel structures for any combination of in-plane loads, pressure and edge moments. The program, which models a structure with linked plate elements, also has the capability to account for initial (bow type) imperfections. PASCO consists of a buckling analysis program (VIPASA),

a non-linear mathematical programming optimizer (CONMIN) and material failure analysis capability. The optimizer has the added capability of allowing constraints on the dimensions in order to avoid an impractical design solution. The ability of this program to rapidly model and optimize a structure for a variety of load conditions and design constraints made it particularly useful in this trade study.

Table 1, L-1011 Wing Box Design Criteria at OWS 151.0.

N_x	-14000 lb/in (compression)
N_{xy}	2000 lb/in (shear)
Pressure	10.38 psi burst, 7.82 psi crushing
Eccentricity	.1%
G_t minimum	.70 x 10 ⁶ psi

Table 2, Preliminary Sizing Parametric Analysis Matrix.

STRINGER TYPE	STRINGER SPACING (inches)	RIB SPACING (inches)	CONDITIONS
BLADE STIFFENER	4, 5, 6, 7, 8	20, 30, 40	1. Unrestricted 2. "Soft Skin" 3. Design Standards
'J' STIFFENER	4, 5, 6, 7, 8	20, 30, 40	1. Unrestricted 2. "Soft Skin" 3. Design Standards
HAT STIFFENER	6, 7, 8	20, 30, 40	1. Unrestricted 2. "Soft Skin" 3. Design Standards

The conditions in Table 2 are defined as follows:

1. Unrestricted - The PASCO program will provide an optimum configuration without consideration of laminate design standards such as maintaining a minimum percentage of plies in any

direction, damage tolerance requirements, or even number of plies. Laminate symmetry will be enforced.

2. Soft Skin - The PASCO model will be constrained to force a minimum of 50% + 45 degree plies. All other conditions are as outlined above.

3. Design Standards - The PASCO solution will be modified to maintain a minimum of 8% 90 degree plies. Stiffeners will have no more than 60% 0 degree plies, skins will have a minimum of 50% + 45 degree plies. An even number of plies will be maintained.

A wing upper cover with initial eccentricity, which is subjected to lateral pressure while loaded in axial compression is sensitive to the ratio of applied load to critical buckling load. At load ratios (P_a/P_{cr}) above .67, the deflections and moments become excessively amplified. For this reason, a factor of 1.5 will be applied to the ultimate compression load for stability analysis. In other words, the panel will be sized to ultimate load for strength; but to 1.5 times ultimate for stability. This approach to preventing general instability and reducing deflections was outlined in the Composite Transport Wing Technology Development Program (contract NAS1-17699).

The specified minimum G_t in Table 1 represents a typical value for the L-1011 wing. Maintaining this minimum G_t will ensure satisfaction of dynamic requirements, and thereby increase the validity of the predicted weight savings relative to the baseline structure.

The mechanical properties used in this preliminary sizing study were for an IM7/HTA thermoplastic:

$$E_{1-t} = 25.5 \text{ MSI}$$

$$E_{1-c} = 20.5 \text{ MSI}$$

$$E_2 = 1.35 \text{ MSI}$$

$$G_{12} = 0.65 \text{ MSI}$$

$$\nu_{12} = 0.36$$

$$\rho = 0.059 \text{ lb/in}^3$$

After the parametric studies of the three structural concepts were completed, the upper cover of the RTM concept was re-sized using properties for an AS-4/toughened epoxy material system. The resulting panel configuration was approximately 12% heavier than the IM-7 cover.

The results of the parametric analyses are given in Tables 3 and 4. Table 3 contains results for conditions 1 and 2 together because in most instances, the results for both conditions were the same. Where they are different, two entries are made in the table. Note that for the condition 3 analysis, the hat stiffened (braided) concept was not included. The braided concept was eliminated because it would have exceeded the size limitations of existing and projected braiding machinery.

In order to make a more valid weight comparison between the cover concepts, an estimate was made of the rib areal weight for each rib spacing, and added to the cover areal weight. The weight of the wing covers alone decreases with decreasing rib spacing; so, without accounting for the associated increase in rib weight, a true optimum spacing cannot be determined. The optimum (minimum weight) spacing can be determined from the plot of areal weight vs. rib spacing shown in Figures 4 and 5. The tabular results for the total weight of ribs and covers is given in Tables 5 and 6

Based upon the results from the upper cover compression panel study, and from manufacturing considerations, the optimum blade stiffener spacing was determined to be 6.17 inches. The PASCO optimized panel cross section is shown in Figure 6.

1.2.1 Modular Wing

The modular wing concept, in contrast to the other wing concepts, featured discrete upper and lower covers with no spanwise or chordwise joints, separate spars and rib components which were to be subsequently

Table 3, Areal Weight Summary, Covers, PASCO Conditions 1 and 2.

STIFFENER SPACING	20 INCH RIB SPACING (IN)					20 INCH RIB SPACING (IN)					20 INCH RIB SPACING (IN)				
	4	5	6	7	8	4	5	6	7	8	4	5	6	7	8
BLADE	.0190	.0192	.0197	.0197	.0203	.0216	.0214	.0215	.0219	.0224	.0247	.0241	.0238	.0238	.0243
'J'	.0192	.0193	.0197	.0206	.0208	.0206	.0208	.0210	.0216	.0223 .0227	.0226	.0224	.0226	.0230	.0233 .0238
HAT	-	-	.0176	.0175	.0176	-	-	.0187	.0184	.0184	-	-	.0205	.0196	.0196

Single value indicates that condition 1 satisfied condition 2.
Where two values are given, the upper value is condition 1.

12

Table 4, Areal Weight Summary, Covers, PASCO Condition 3.

STIFFENER SPACING	20 INCH RIB SPACING (IN)					20 INCH RIB SPACING (IN)					20 INCH RIB SPACING (IN)				
	4	5	6	7	8	4	5	6	7	8	4	5	6	7	8
BLADE	.0223	.0220	.0221	.0225	.0227	.0239	.0234	.0234	.0245	.0249	.0269	.0262	.0256	.0264	.0264
'J'	.0213	.0212	.0213	.0210	.0216	.0229	.0228	.0228	.0230	.0233	.0246	.0245	.0244	.0246	.0248
HAT	-	-	-	-	-	-	-	-	-	-	-	-	-	-	-

Single value indicates that condition 1 satisfied condition 2.
Where two values are given, the upper value is condition 1.

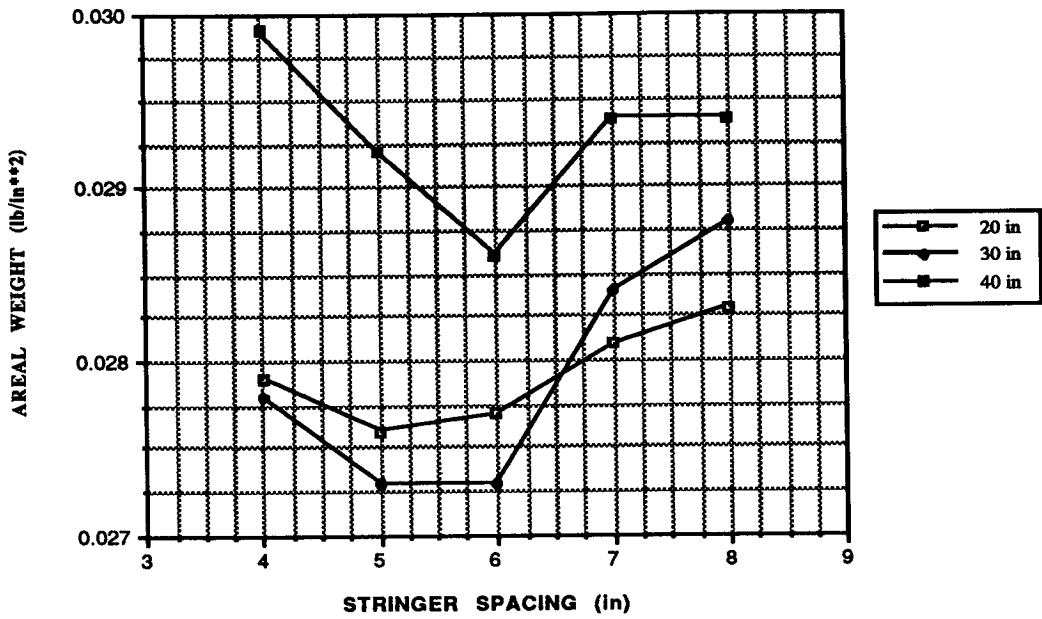

Figure 4, PASCO Condition 3 Blade Stiffened Panels (with rib weights).

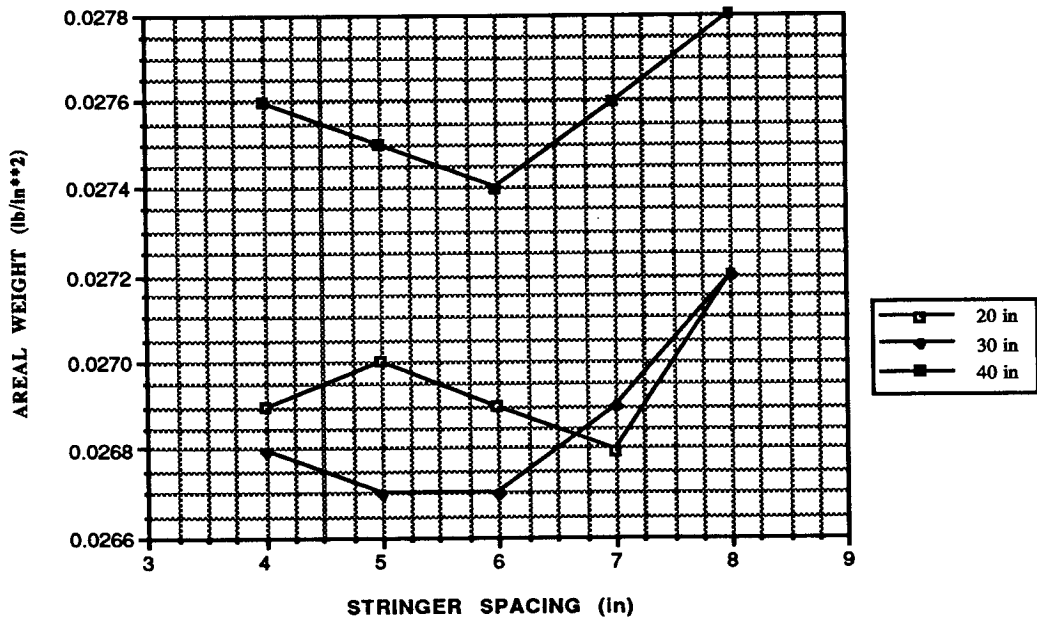

Figure 5, PASCO Condition 3 'J' Stiffened Panels (with rib weights).

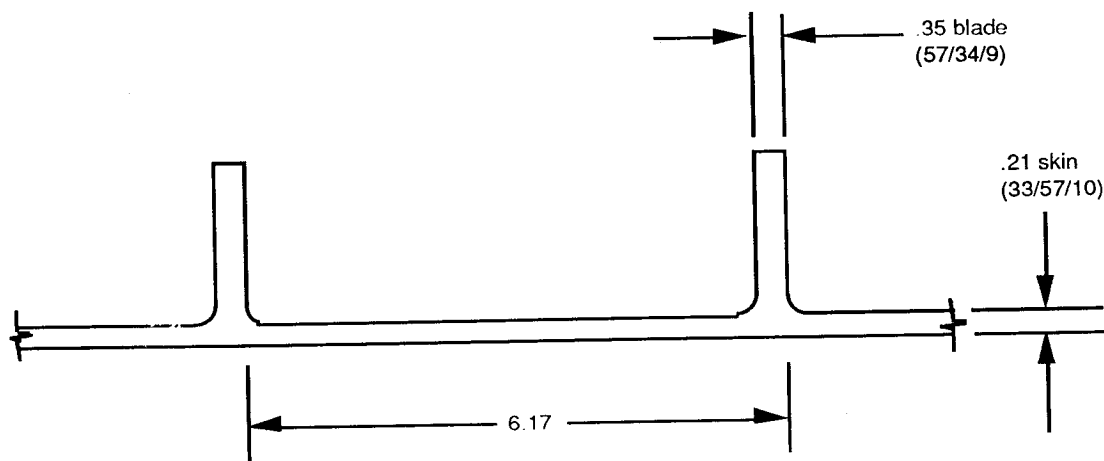

Figure 6, Optimized Upper Cover Cross Section For Modular Wing Box Concept.

mechanically assembled, see Figure 7. This design approach kept the size of individual components within manageable proportions and allowed a variety of low-cost fabrication methods to be utilized. The cost benefits achieved through the use of large one-piece components and optimal fabrication methods was sufficient to offset additional assembly costs. To further help reduce costs automated manufacturing techniques were selected wherever possible.

The upper and lower covers were designed with continuous blade stiffeners running along the entire span of the wing. Two other stiffener configurations were considered, namely 'J' and 'Hat' sections. With these stiffener configurations the stiffener spacing could have been increased (decreasing the total number of stiffeners required), but the added complexity in manufacturing and assembly was not cost effective. One of the concerns with composite stiffened skin designs is the peeling or separation of the stiffener from the skin under load, particularly for post-buckled structures. The concept, shown in Figure 8, resolved that concern by embedding the base flanges of the stiffener within the skin laminate, which provides a mechanical lock of the stiffeners in addition to the bonded joint.

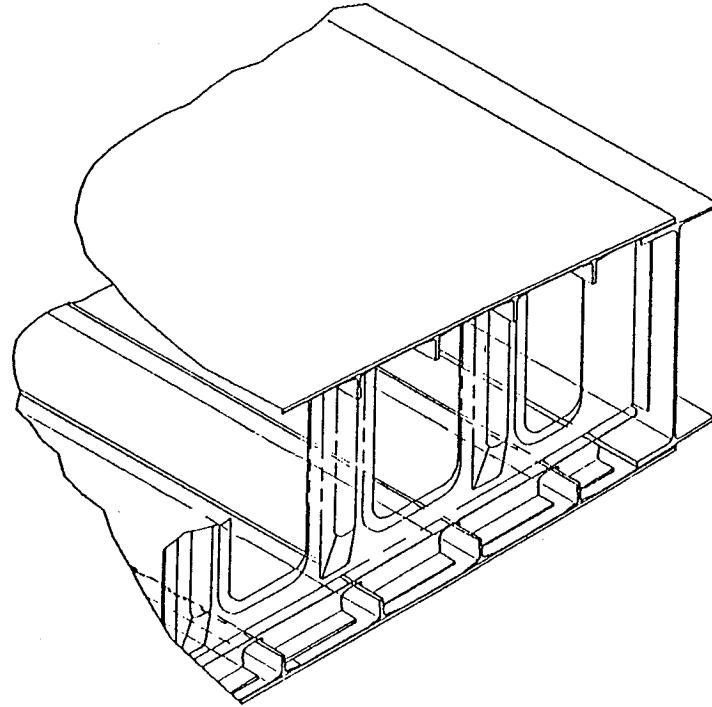
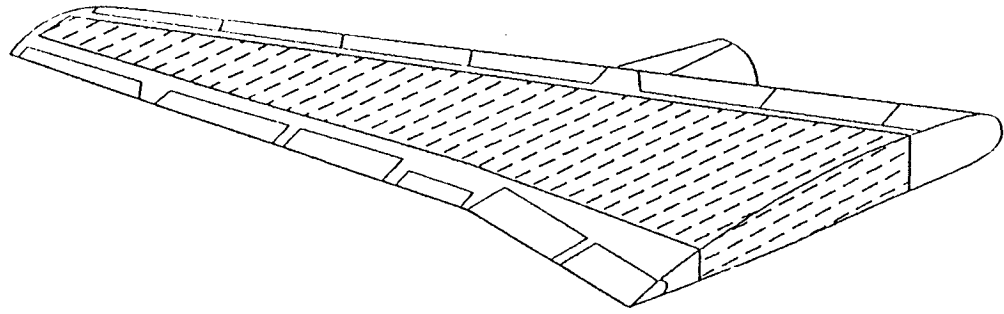

Figure 7, Modular Wing Concept.

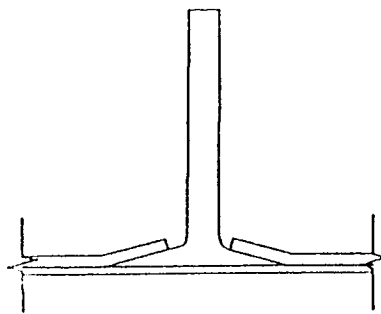

Figure 8, Embedded Stiffener Configuration For Modular Wing Concept.

In keeping with the design philosophy of minimizing the use of fasteners, the rib caps and shear ties would be co-cured with the covers, see Figure 9. The rib caps are 'mouse holed' at the stringer intersection to allow for the continuous stiffeners. Another feature of the rib caps is the integral shear ties to the stringers made by folding the mouse hole material to form a 'clip' instead of cutting the mouse hole material away. The rib web which was used to carry the crushing/tension/shear loads, is a hat stiffened web with flanges formed at the front and rear for attachment to the spars. Also included in the rib design is a flange at the top and bottom to form the rib chords. The rib chords are required because the rib caps had cut outs and does not provide adequate stability. The front and rear spars are 'I' section beams with co-bonded blade stiffeners and are mechanically attached to the skin. Mechanical attachment is necessary for the final assembly of the wing components. Figure 10 shows the overall configuration of the spars and rib webs.

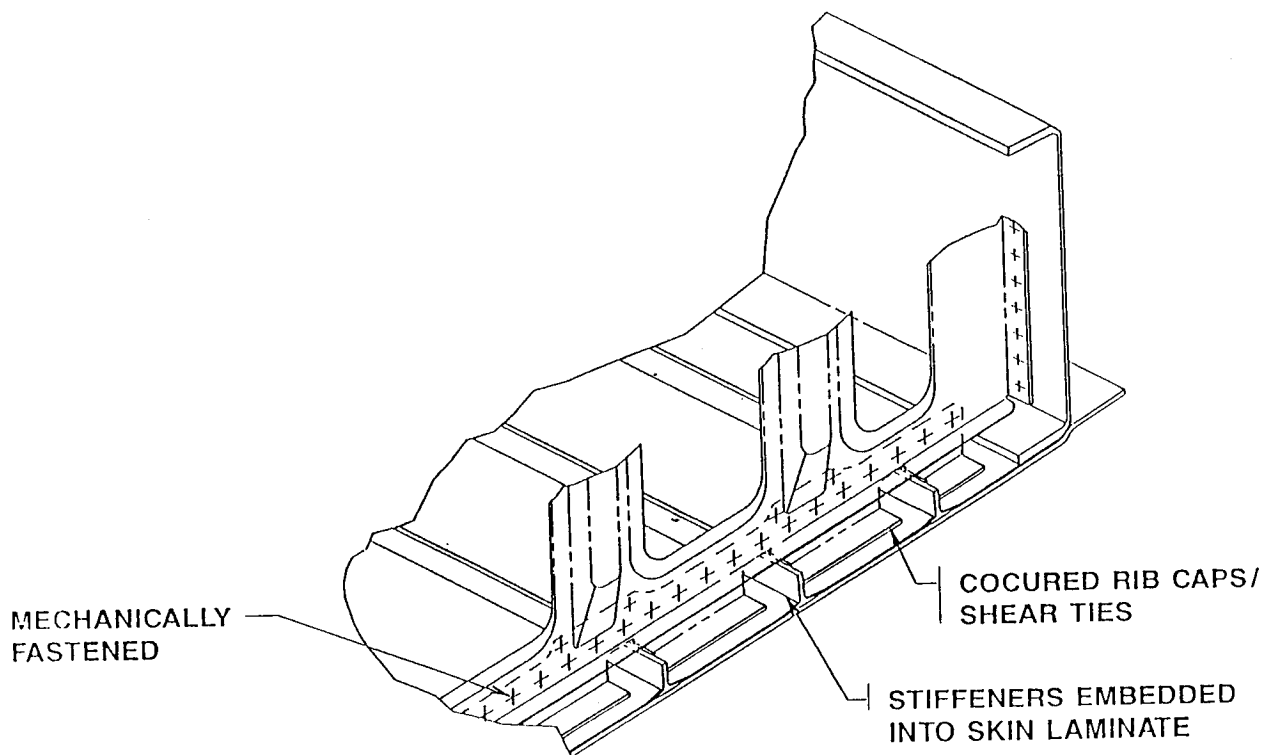

Figure 9, Co-Cured Rib Caps/Shear-Ties.

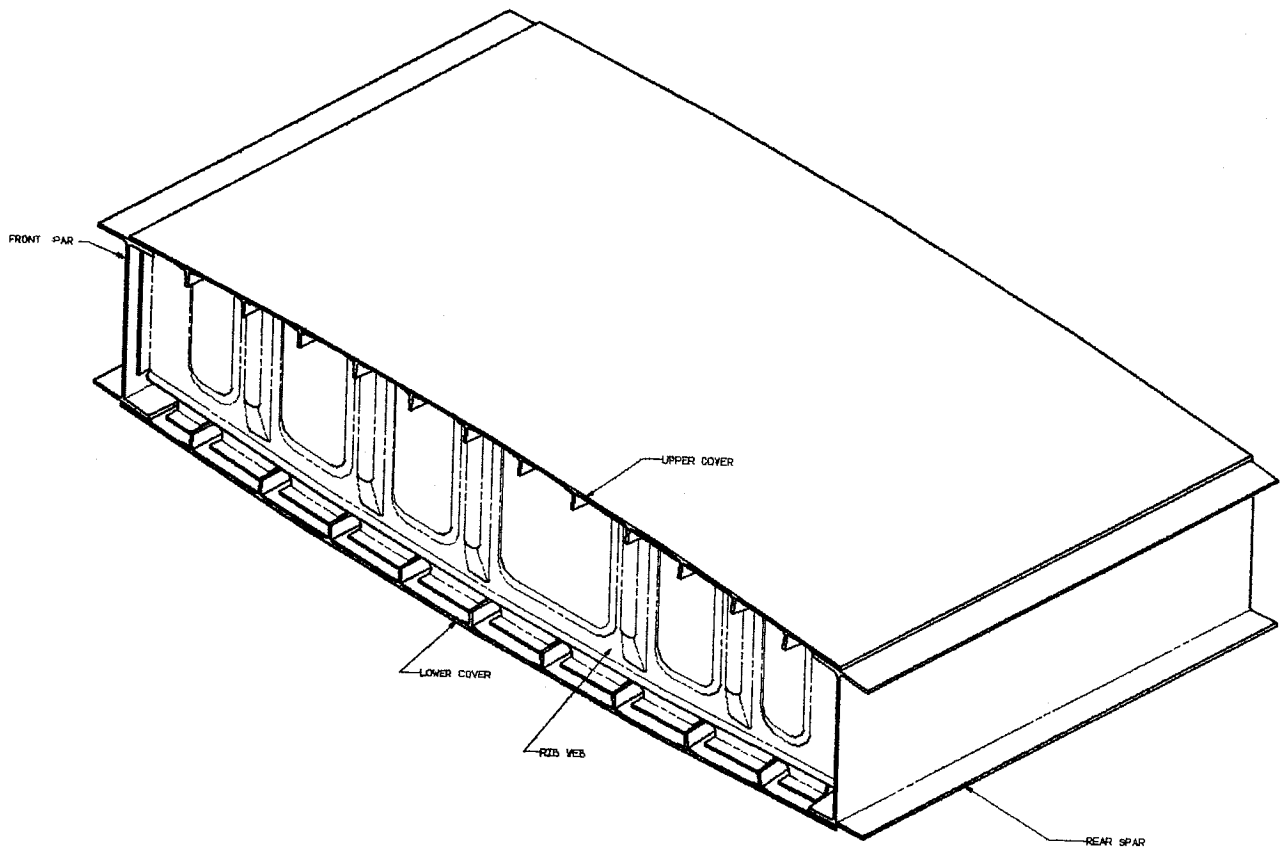

Figure 10, Spars And Rib Web Configuration.

The manufacturing plan for the upper and lower covers includes co-curing of continuous stiffeners with the base embedded into the skins. Multi-axial stitched preforms and resin film infusion (RFI) were chosen for stiffener fabrication. In the RFI process, resin film is melted into dry preforms. The preform can then be inserted into an integrally heated tool for final part fabrication in a pressure vessel. Use of a pressure vessel is an inexpensive way to apply pressure and fabricate parts. The stiffeners are fully cured and co-bonded to the skins. Manufacture of rib caps is to be accomplished by oven molding form prepreg. Rib caps are to be advanced to an advanced B-stage to allow for subsequent co-cure within the cover assembly. The skin subassembly is produced by inserting the rib cap preforms into recesses of the skin tool and laying an initial plyset (by automatic tape laying or hand lay-up) of the skin material. Cured

stringers are then located and the remaining skin plies automatic tape laid. This assembly is then conventionally bagged and cured in an autoclave.

Manufacture of the spars includes the use of pultruded blade stiffeners and 'C' section preforms made by automated tow placement. Pultruded stiffeners are placed into recesses of the tool which are then used as a mandrel for automated tow placement, as illustrated in Figure 11. This assembly is subsequently split along the length to produce two 'C' sections. The sections are placed back-to-back to form the 'I' beam with canted flanges and co-cured in an autoclave. The rib webs are the only thermoplastic parts in the modular wing concept and were designed to be press formed/compression molded from a flat plyset and then waterjet cut to shape.

A summary of the materials chosen for each component along with the manufacturing method are shown below in Table 7.

Table 7, Material Selection And Fabrication Method For Modular Wing Concept.

MATERIAL SELECTION SUMMARY			
	MFG METHOD	MAT'L SELECTED	COMMENTS
COVERS ASSY			
STIFFENERS	RESIN INFUSION	8552 RESIN/IM7 PREFORMS	
RIB CAPS	HAND-LAYUP UNI-TAPE	IM7/8552	
COVERS	ATL	IM7/8552	WIDE WIDTH PREPREG
SPAR			
SPAR WEB	ATP	IM7/8552	TOWPREG
SPAR STIFF	PULTRUSION	IM7/8552	TOWPREG
RIB WEB	ATL/COMP MOLDING	APC-2	UNI-TAPE OR QUADRAX

Final assembly of the various components is accomplished by sealing and fastening the front and rear spars to the upper and lower covers as is done with conventional aluminum structures. The rib webs are subsequently attached using access holes or internal access.

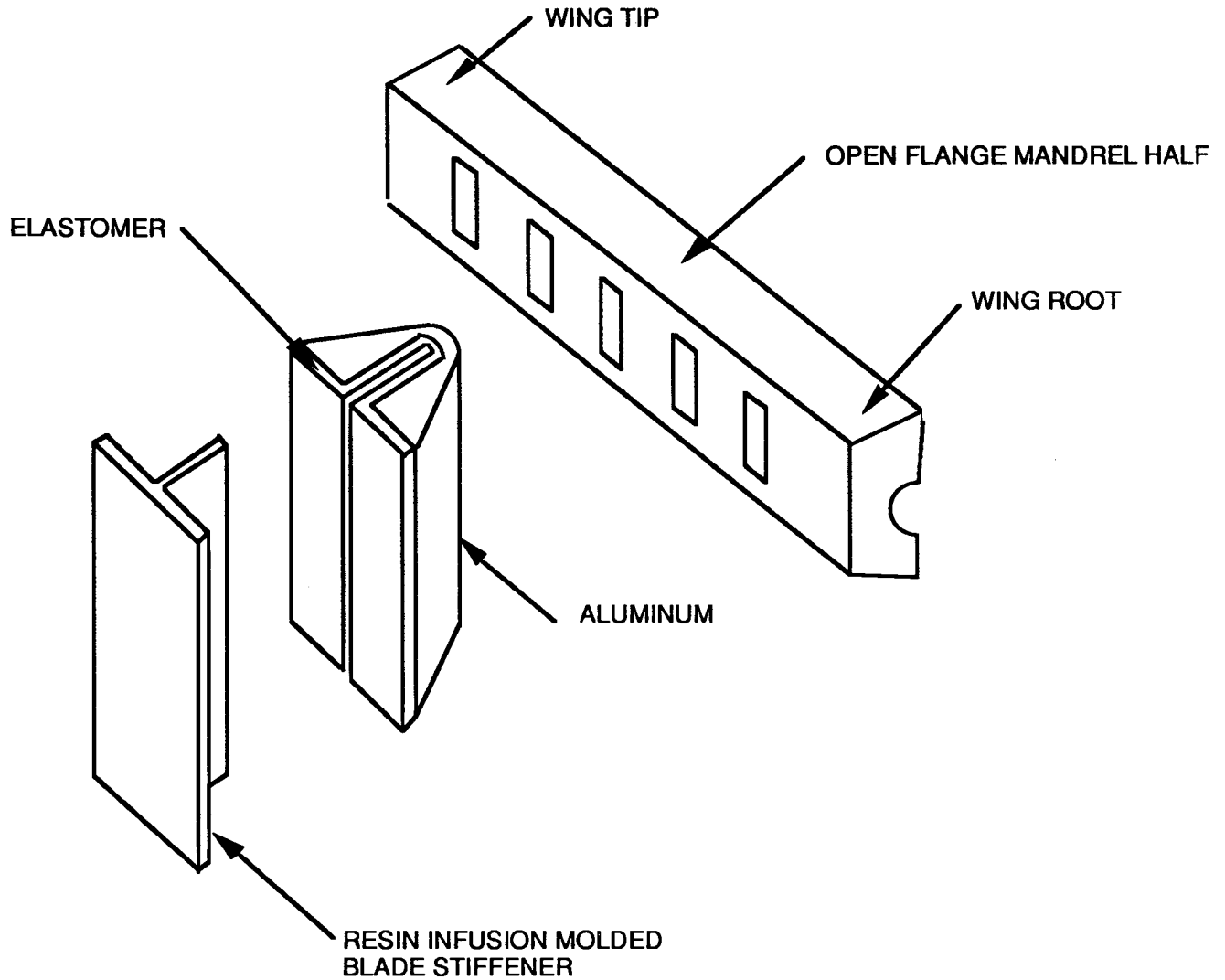

Figure 11, Spar Tooling Approach.

2.2.2 Resin Transfer Molded Wing

In order to reduce costs the resin transfer molded (RTM) wing concept was originally conceived as a one piece wing with no spanwise or chordwise joints. Due to the manufacturing complexity however, this basic approach was changed to a two piece wing box with spanwise splices in the spar webs. This resulted in two major subassemblies; the lower cover/spar web and the upper cover/spar cap, which are then joined

through rib webs. Resin transfer molding was selected as the preferred manufacturing method for the upper and lower cover subassemblies.

The upper cover, shown in Figure 12, included continuous blade stiffeners similar to the Modular wing concept, except that the stiffeners are stitched to the cover to resist the peel loads/effects. Stitching was chosen to reinforce the joint because embedding the stiffener within the skin laminate was not deemed practical in this application. In addition, the base flanges of the stiffeners are feathered to reduce the loads at the free edges, see Figure 13. Before selecting the blade stiffener configuration, hat stiffeners were also considered. However, they were eliminated because of the added tooling risks/complexity of having to remove the long (and possibly entrapped) mandrel required to form the hat cross-section.

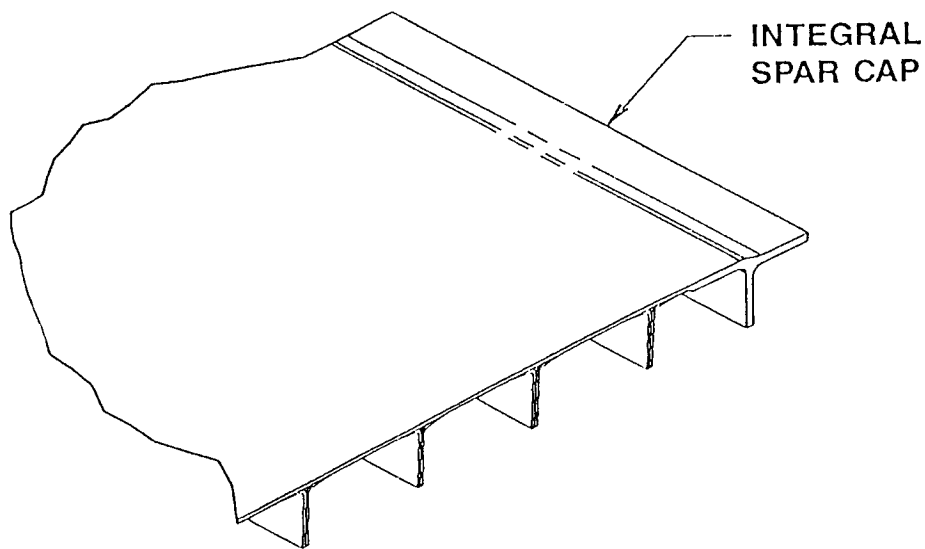

Figure 12, Upper Cover With Integral Spar Cap.

Integral spar caps are an added feature of the RTM wing concept. The spar caps were added to the cover subassembly to reduce final assembly costs and also to greatly minimize fuel sealing requirements. It should be noted that while adding these features increases tooling

complexity and tool costs they reduce subsequent recurring assembly costs, one of the main cost drivers. This points out one of the risk areas of the RTM concept. Although resin transfer molding has been shown to be a low-cost, reliable manufacturing approach for small parts/assemblies, its use in very large structures has not been verified and "scale-up" is a major concern.

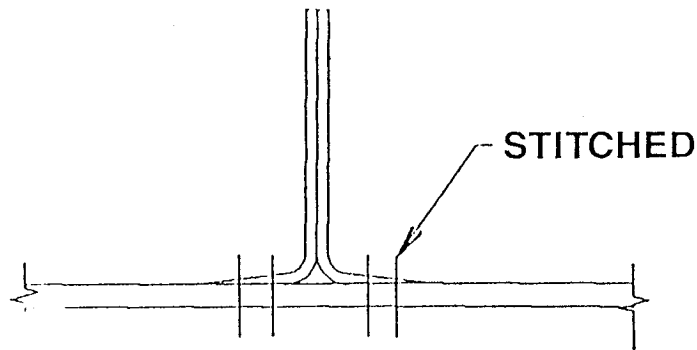

Figure 13, RTM Wing Concept Stiffener Configuration.

The lower cover, see Figure 14, is similar to the upper cover but takes the idea of combining components one step further in that it has integral spar webs in addition to the spar cap. The spar web is basically an extension of the spar cap vertical flange. Both covers also have integral "mouse holed" rib caps with shear ties to the stiffeners. "Mouse holing" of the rib caps allows the blade stiffeners to be continuous, eliminating joints. Rib attachment flanges are also included in the front and rear spars to complete attachment of the ribs and eliminating the need to have separate attach angles.

The manufacturing plan for the RTM wing concept calls for the stiffeners to be made from dry fabric plysets cut to shape and partially stitched to form the blade section (upstanding leg) of the stiffener. The base flanges are then folded out to form the feathered legs which are subsequently stitched to the skin preform. Note that the feathering or tapering of plies must be contained within the preform and can not be formed by simply bending the base material and by fiber slippage. The spar caps are developed in a similar manner, except that all three flanges

are stitched to form the "T" shape of the spar cap and then stitched to the cover skin preform. As previously discussed the rib caps have cutouts to allow for the stiffener carry-through. The rib caps are made by hand laying dry fabric plysets cut to appropriate dimensions and stitching to hold shape. All the component preforms are then stitched to the cover skin preform which is also a dry fabric stitched plyset incorporating all the needed ply drop-offs and pad-ups. Once all the components are stitched together to form the cover assembly, the preform is ready to be loaded into the RTM tool for resin injection.

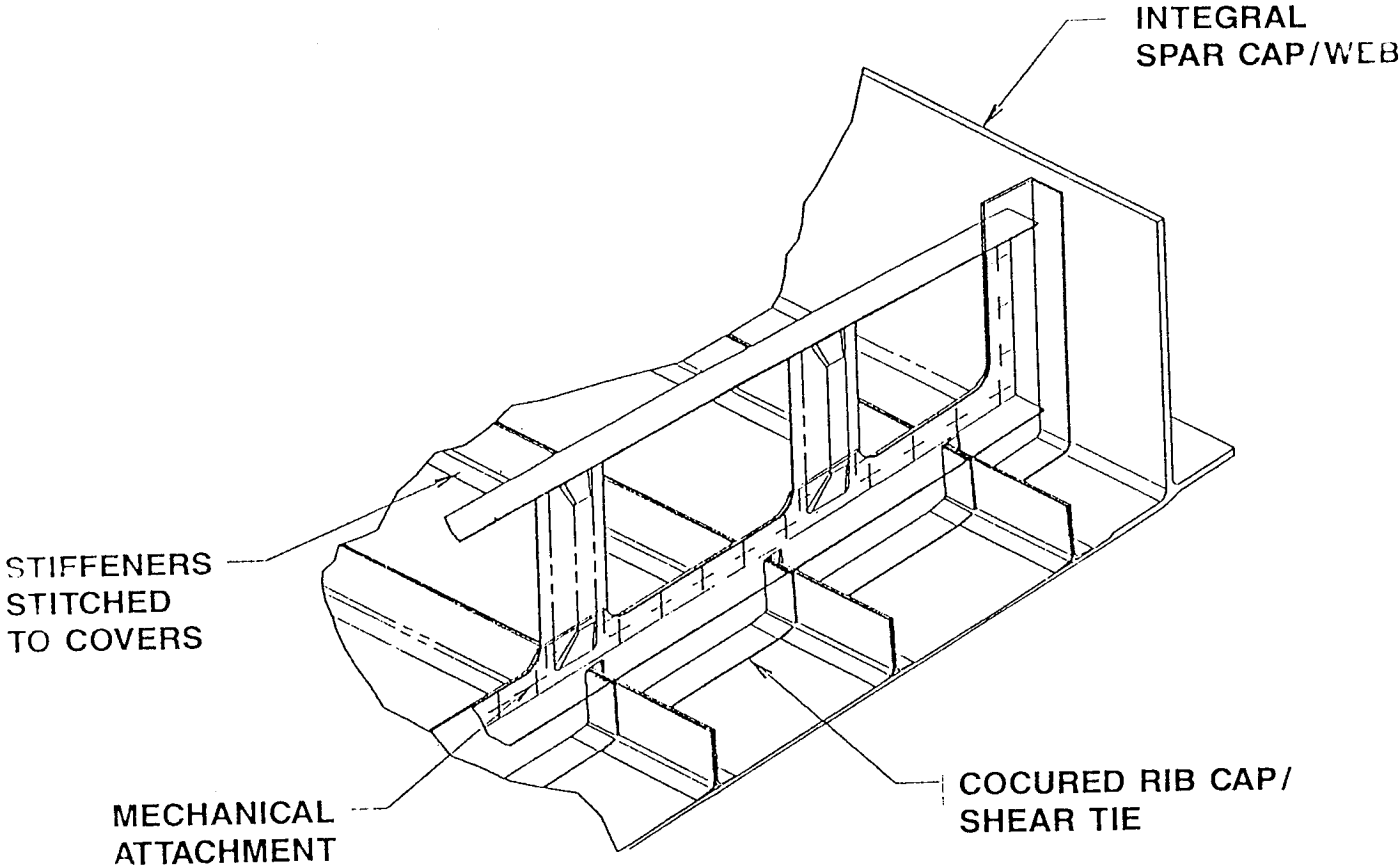

Figure 14, Lower Cover With Integral Spar Cap/Web.

Loading of the preform into the RTM tool is one of the critical issues with the RTM concept, preform structures of this size and magnitude have never been handled before. Debulking and correct preform insertion into the tool becomes necessary to maintain dimensional tolerances. Another area of possible concern with the RTM concept is the substantial amount of stitching required. Stitching through larger thicknesses may require that appropriate measures be taken to ensure that fiber damage is eliminated/minimized through the use of special stitching techniques such as, ultrasonic needle vibration.

The rib webs, see Figure 15, are made by compression molding a thermoplastic laminate (constant thickness) to form a bead stiffened web. Return flanges are incorporated on the upper and lower sections of the rib webs form additional chord material and providing a continuous load path over the mouse holed rib caps. Also note that additional flanges forward and aft are not required for attachment to the spars because attachment is provided through attachment flanges incorporated in the spar webs.

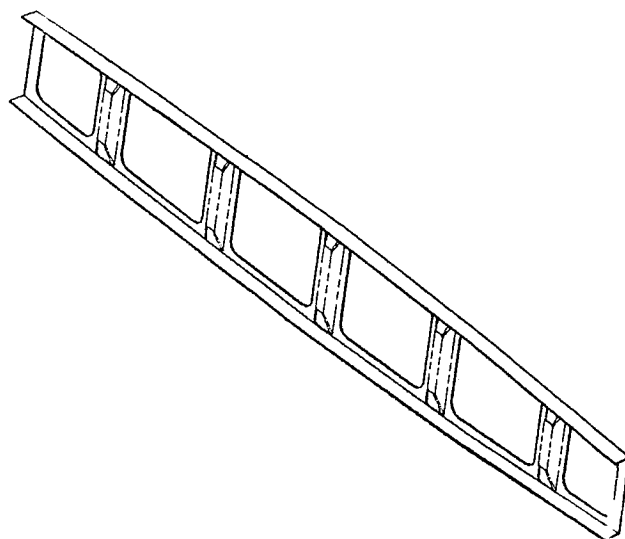

Figure 15, Integrally Stiffened Thermoplastic Rib Web.

A summary of the materials chosen for each component along with the manufacturing method are shown below in Table 8.

**Table 8, Material Selection And Fabrication Method
For RTM Wing Concept.**

MATERIAL SELECTION SUMMARY			
	MFG METHOD	MAT'L SELECTED	COMMENTS
COVER ASSY			
SKIN/STIFFENER/ SPAR/RIB CAP	RTM	IM7/AS4 PREFROM, PR 500 RESIN	FABRIC PREFORMS HBRF311 RESIN (ALT.)
RIB WEBS	COMPRESSION MOLDING	IM7/APC-2	TAPE

Final assembly of the upper cover, lower cover and rib webs is accomplished by mechanically fastening the rib webs to the lower cover subassembly near the wing tip and progressing towards the wing root. Near the wing root where there is more access, the ribs are attached from within. Pilot holes are pre-drilled into the upper sections of the rib webs to facilitate subsequent attachment to the upper cover. The upper and lower covers are positioned, sealed and fastened together.

2.2.3 Automatic Tow Placement Wing Concept

The automatic tow placed wing concept, see Figure 16, was designed to take full advantage of the automated manufacturing process. As in the other wing concepts the ATP concept strove to minimize parts count by co-curing several components into large subassemblies. Inherent in the ATP process is the capability of providing areas of thickness increases and decreases (ply pad-ups and drop-offs) that are necessary for cost and weight efficient structures. Some of the design features of the concept are; one piece covers designed with integral blade stiffeners, integral spar caps and integral rib caps with shear ties, see Figure 17. The ATP concept also had the simplest rib web and spar web designs which are basically stiffened web designs. Both upper and lower covers are structurally identical with the only difference being in the thicknesses, sizing and stiffener spacing.

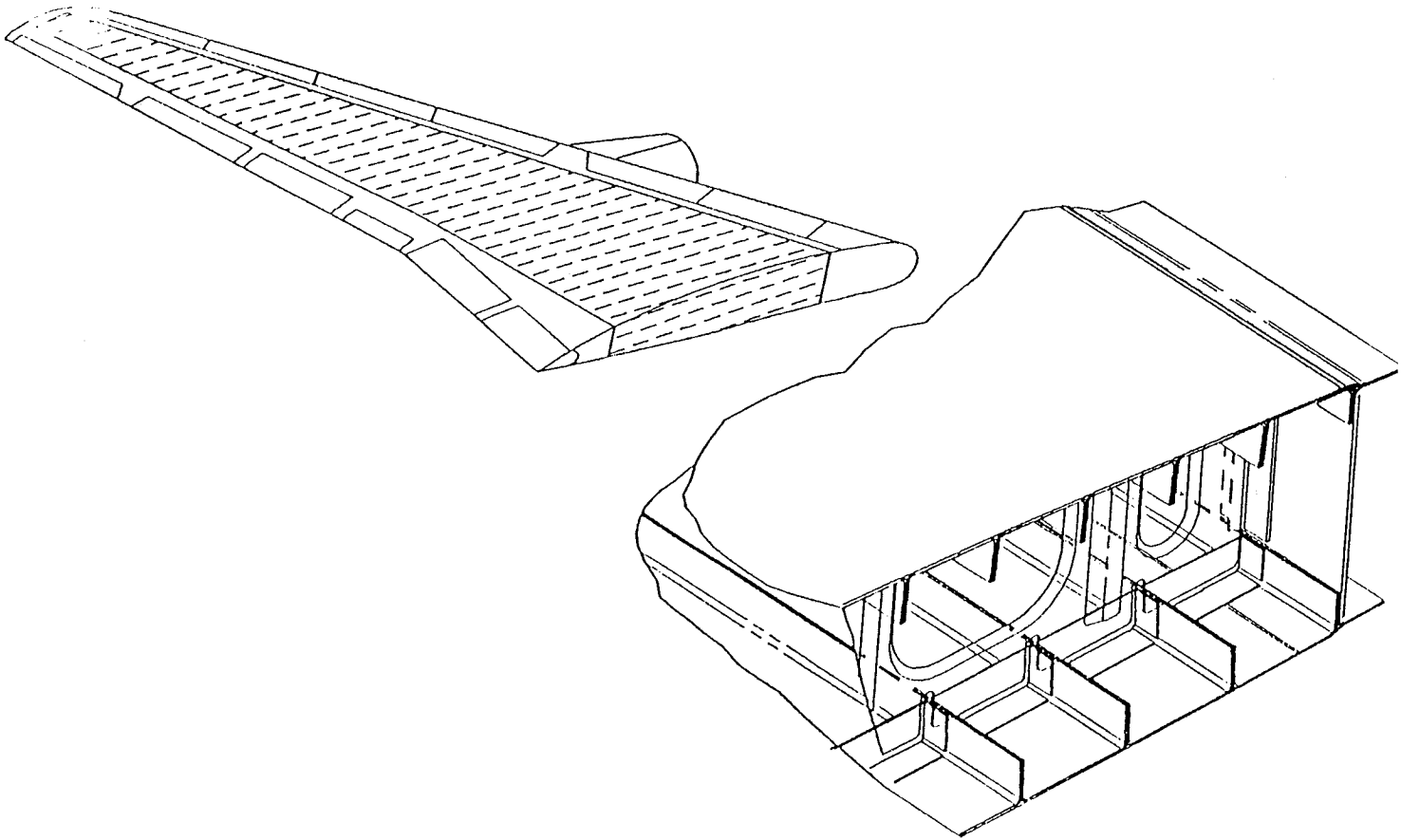

Figure 16, Automatic Tow Placed Wing Concept.

Early in the design development phase of the ATP concept continuous blade stiffeners were selected as a low cost manufacturing approach. The stiffeners are made by tow placing around a tapered rectangular mandrel. Separating the mandrel into halves forming "U" channels that are placed side-by-side to form the blade stiffeners. Pultruded stiffeners are then added in-between the "U" channel sections to fill the radius gaps, see Figure 18. Other stiffener configurations were not deemed feasible or cost effective with the ATP process. Using this process allows the spar caps to be made integral with the skins which reduces the number of

potential fuel leak paths and further reduced assembly costs. The spar caps are developed in a similar manner to the stiffeners with material being laid-up on tapered mandrels. However, the spar cap is built-up using one half of a stiffener "U" channel and a tow placed "L" section for leading edge attachment.

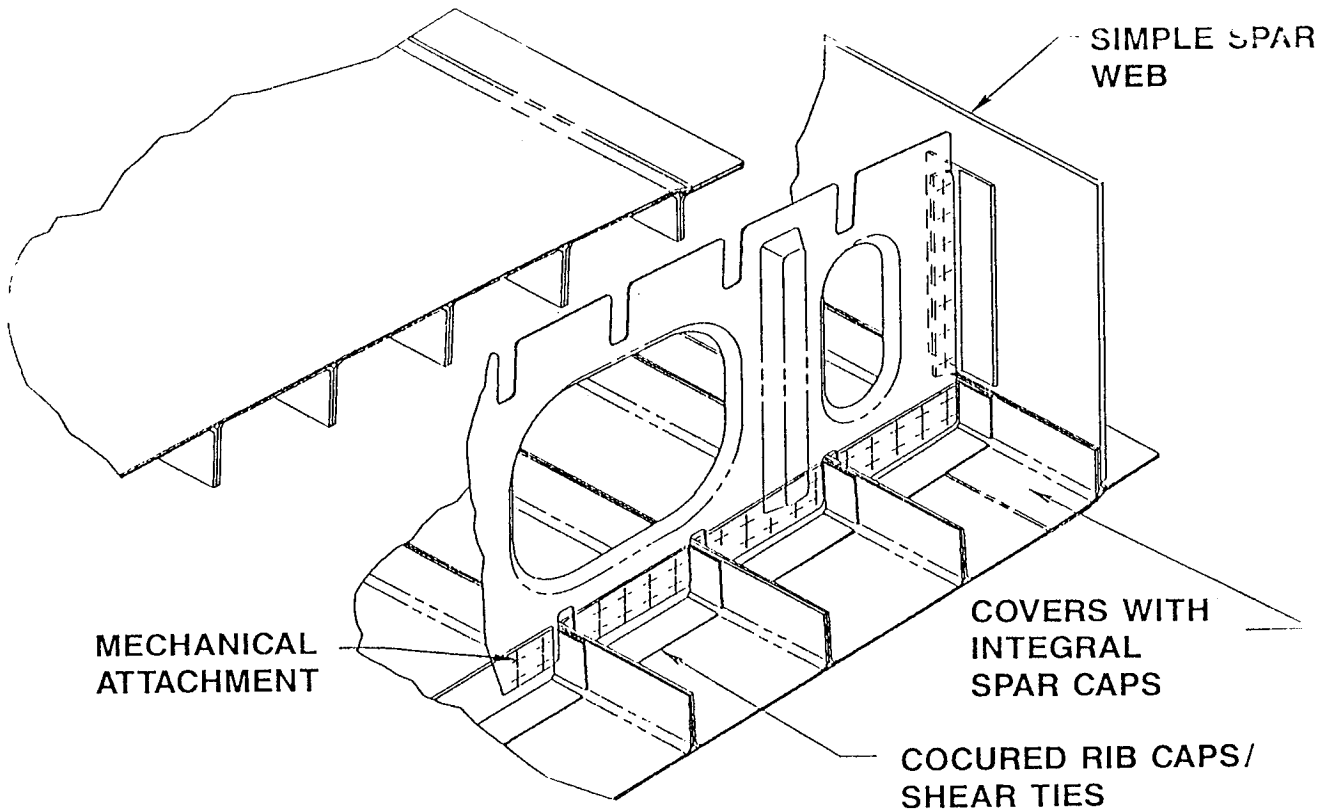

Figure 17, ATP Wing Concept Details.

Integral rib caps act as shear ties for the rib webs and stabilize the continuous blade stiffeners. This rib cap design differs from the other rib cap designs because of the manufacturing approach. Rectangular mandrels are used to lay-up the stiffener material which requires that the rib cap preforms be inserted into the mandrels first. Therefore, the rib caps could not be made continuous. The rib cap preforms are made by placing woven prepreg material on an oven mold block for debulking. After debulking, the preforms are reloaded into the "U" channel mandrels prior to laying-up the blade stiffener material.

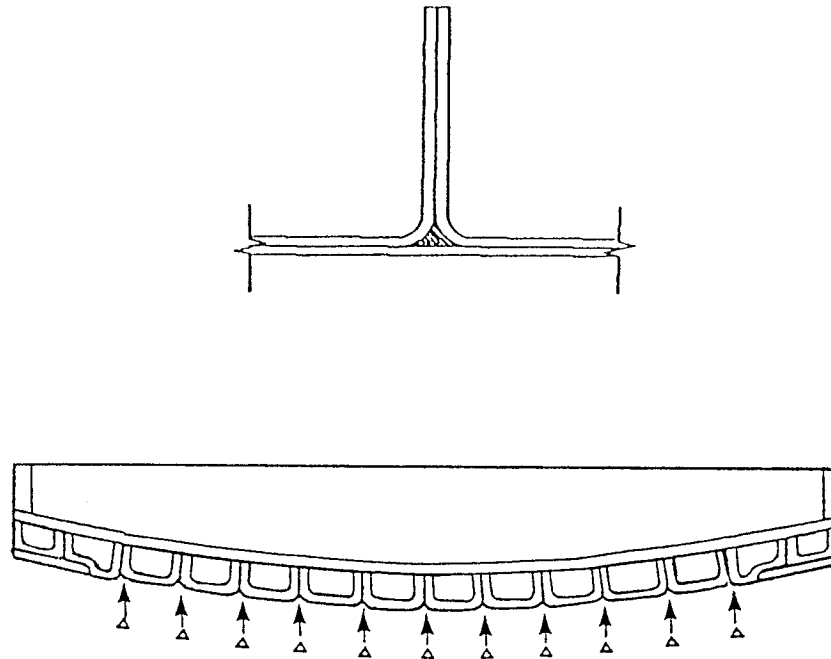

Figure 18, "U" Channel Build-up and Stuffer Insertion.

The rib webs were designed as a constant thickness hat stiffened plate. They are made by compression molding of an automatic tow placed thermoplastic laminate and subsequently waterjet cut to final trim dimensions. Note that the web does not have return flanges. The spar web is a blade stiffened shear web manufactured by placing the stiffeners into recesses of a tool and tow placing the web material to form the subassembly. As discussed above these two components are of simple design and represent a low-risk approach.

A summary of the materials chosen for each component along with the manufacturing method are shown in Table 9.

**Table 9, Material Selection And Fabrication Method
For ATP Wing Concept.**

	MATERIAL SELECTION SUMMARY		COMMENTS
	MFG METHOD	MAT'L SELECTED	
COVERS			
SKIN	ATP	IM7/8552	TOWPREG
STIFFENERS	ATP	IM7/8552	TOWPREG
RIB CAPS	HAND LAYUP	IM7/8552	PREPREG
STUFFER	PULTRUSION	IM7/8552	TOW PREG
SPAR ASSY			
SPAR	ATP	IM7/8552	TOW PREG
STIFFENERS	PULTRUSION	IM7/8552	TOW PREG
RIB WEBS	PRESS FORMING	IM7/PEI	UNI-TAPE/QUADRAX

Final assembly of the ATP wing concept is accomplished by fastening the lower sections of the rib webs to the lower cover towards the wing tip where access is limited by size. Pilot holes on the upper sections of the rib web provide locations for drilling and installing fasteners to the rib caps on the upper cover. The front and rear spar webs are then sealed and fastened to the spar cap on the lower cover. The two box halves are then aligned, sealed and fastened in a assembly fixture. At the rib locations near the wing tip, the remaining fasteners are then installed through access holes. The remaining inboard rib webs are then mechanically fastened to the rib caps through access holes or from within the wing when there is sufficient access.

2.2.4 Braided Wing Concept

The braided wing concept was developed as an entirely braided one piece wing, see Figure 19. Included in the design were; integral stiffeners, integral spar caps on the upper, integral spar cap/web on the lower cover and co-bonded rib caps. However, the braided wing concept was dropped from further development due to the limitations of current braiding equipment and the concern with mechanical properties. Following

discussions with several braiding vendors it became apparent that the current state-of-the-art braiders could not produce any structures approaching the sizes needed for the wing concept. Some vendors estimated that the machine would require a ten story building to house a braider large enough to produce such large structures.

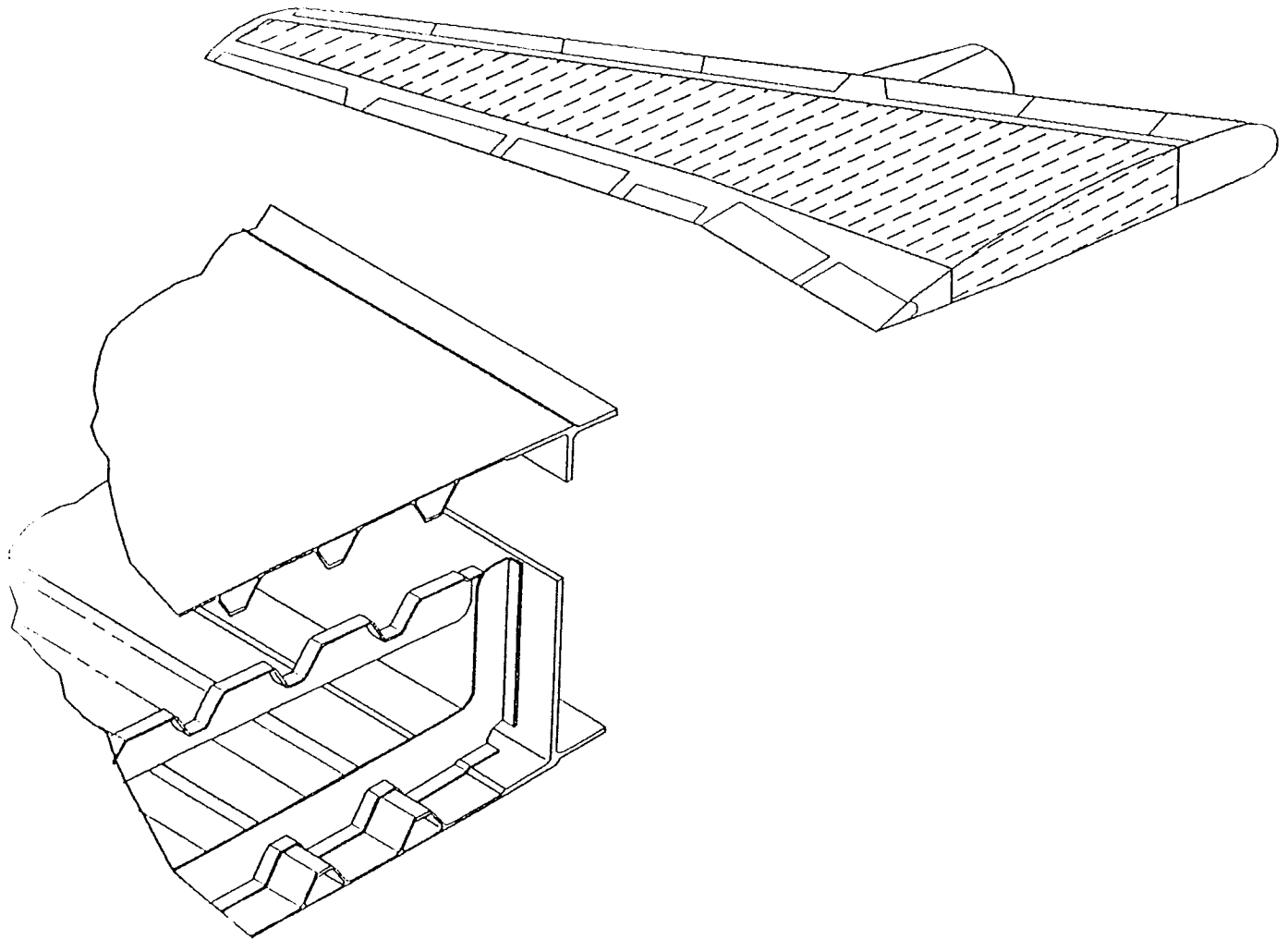

Figure 19, Braided Wing Concept.

Before stopping development of the braided concept, smaller wing components were proposed. For example, the wing was broken down into two or three braided segments, as shown in Figure 20, but they were eliminated due the increased assembly costs and the fact that the size was still an issue.

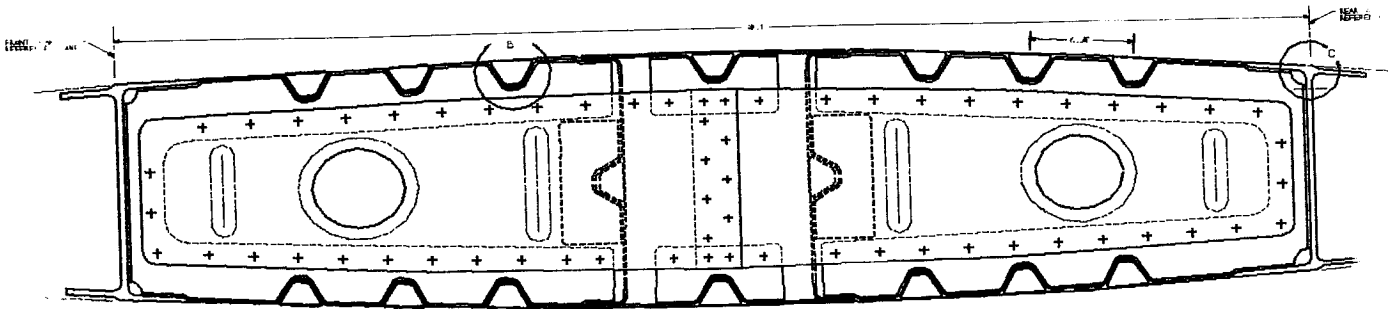

Figure 20, Revised Braided Concept.

Although braiding was eliminated as a wing concept, braiding of smaller components is still considered as a viable manufacturing method. Using the “blank sheet” design approach braiding could still be applied to the manufacture of frames or stiffeners for example.

2.3 Design Trade Studies Of Fuselage Concepts

A similar approach to that used in the development of the Wing Concepts (see Section 1.2) was used for the development of the Fuselage Concepts. Three concepts were developed, namely; the Sandwich, the Geodesic and the Stiffened Shell fuselages. Structurally, the three concepts vary significantly, but all concepts were developed with the same design philosophy. The use of low-cost automated manufacturing processes with the appropriate material forms and co-cured subassemblies were combined to form cost and weight efficient design concepts.

Fuselage Stress Analysis

Sandwich Fuselage Design

The (Lockheed) PANDA2 program was used to optimize the structural

configuration for this concept. The panel was analyzed as a wide column, 200 inches wide and 20 inches long. This configuration represented a quarter panel between adjacent frames. The longitudinal frame attach blades were disregarded as panel breakers and were sized entirely by the cover/frame joint requirements.

Unidirectional tape properties were used for sizing purposes. A tri-axial $0^\circ/\pm 45^\circ$ braid was assumed for the tubes. Three loading conditions were used in the analysis. The conditions were maximum tension from the crown region of the fuselage, maximum shear from the side of the fuselage, and maximum compression from the keel region. In order to minimize manufacturing cost, the final configuration was sized to satisfy all three load conditions. The loads were taken from Lockheed stress reports and are summarized in Table 10.

In the tension cases, the in-plane tension loads due to internal pressure were added to the in-plane loads from fuselage bending. For the compression loads, the in-plane tension from pressure was not superimposed. Table 11 shows the loads summary after accounting for internal pressure. In all cases, the fixed edge moments were applied to the panels to simulate the local bending induced by the internal pressure. Local buckling was not permitted at limit load in these analyses.

Table 10, Design Loads Without Internal Pressure for L-1011 Fuselage at FS 750.0

	CROWN		SIDE PANEL		KEEL	
	Tension	Compression	Tension	Compression	Tension	Compression
Nx	1307	-489	432	-705	318	-943
Ny	-	-	-	-	-	-
Nxy	+150	+150	+600	+600	+300	+300

All loads are in lb/in

**Table 11, Design Loads With Internal Pressure for L-1011
Fuselage at FS 750.0**

	CROWN		SIDE PANEL		KEEL	
	Tension	Compression	Tension	Compression	Tension	Compression
Nx	1883	-489	1008	-705	894	-943
Ny	1152	-	1152	-	1152	-
Nxy	+150	+150	+600	+600	+300	+300

All loads are in lb/in

Two configurational constraints were imposed upon the optimization for manufacturing considerations. The first restriction was that the height of the truss core had to be greater than .44 inches (in combination with the facings, the total section had to exceed .50 inches in depth). The second restriction was that the pitch of the truss tubes could not exceed 1.5 inches (this gave a minimum corner angle of approximately 36 degrees).

Minimum gage requirements sized the facings in the panel optimization at seven plies. For verification, the resulting configuration was then analyzed for panel buckling using the BOSOR4 program. A 10 inch panel width was used in this analysis. Good agreement between the PANDA2 and BOSOR4 eigenvalues was achieved.

An additional sizing study was conducted without geometric constraints to develop a pure weight optimized configuration. Minimum gage was still maintained for the facings in this analysis. The panel configurations resulting from the two sizing studies are shown in Figure 21.

Geodesic Fuselage

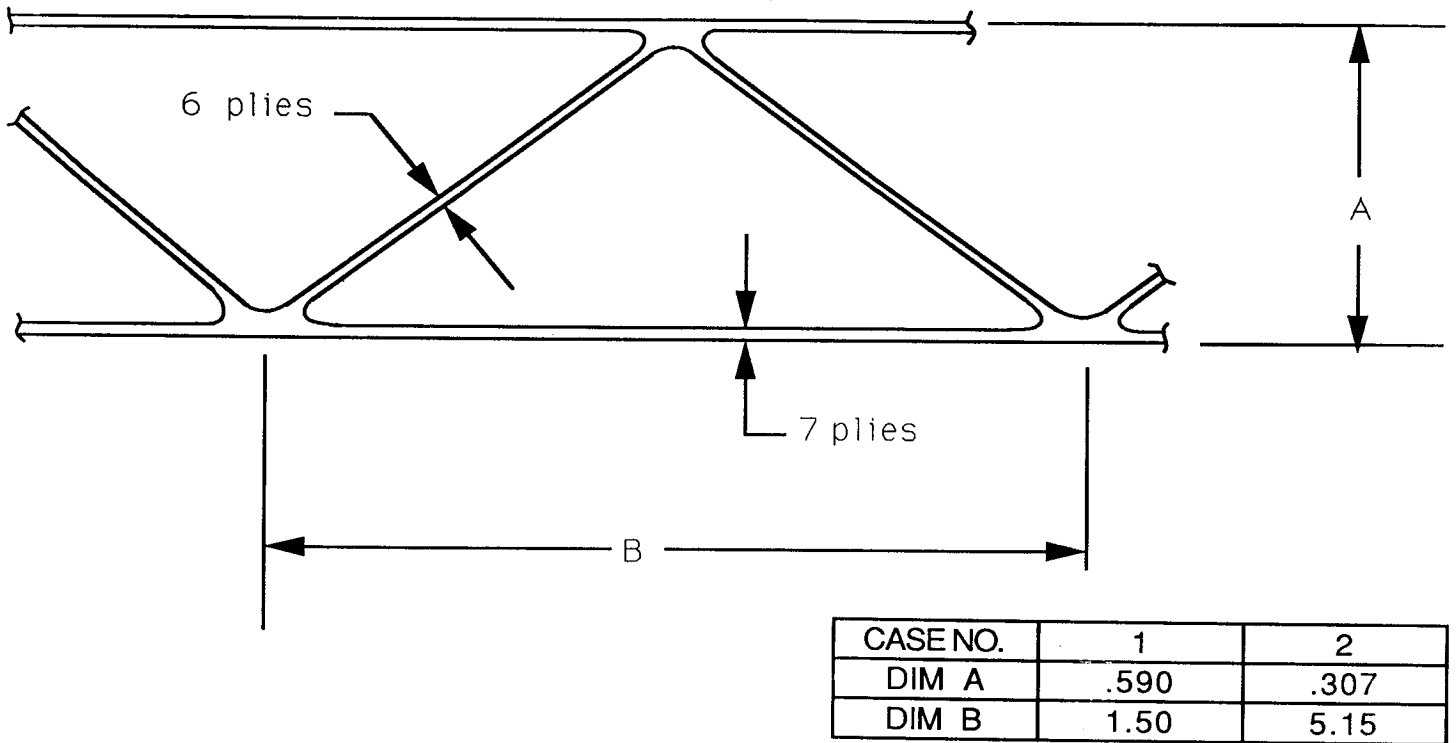

Figure 21, Sandwich Panel Sizing Results

Figure 22, shows the general configuration of a geodesic stiffened panel and the definition of the design variables used in this sizing study. The spacing of the circumferential frames was held at the baseline value of 20 inches, which is the current window spacing. The acceptable ranges for the sizing variables were set at:

$$\begin{aligned}
 40^\circ < \alpha < 60^\circ & \quad 20'' < d < 40'' \\
 .10'' < a < .50'' & \quad .75'' < b < 3.50'' \\
 t = .040'' & \text{ minimum}
 \end{aligned}$$

The DIAL finite element code was used to size this configuration. The analysis was performed for a flat panel with frame spacing set at 20 inches. Figure 23 shows the plot of the finite element model geometry and the mode shape from the buckling analysis is shown in Figure 24. DIAL is not an (automatic) optimization program, so the the model was run

repeatedly, changing the design variables, to determine a minimum weight configuration.

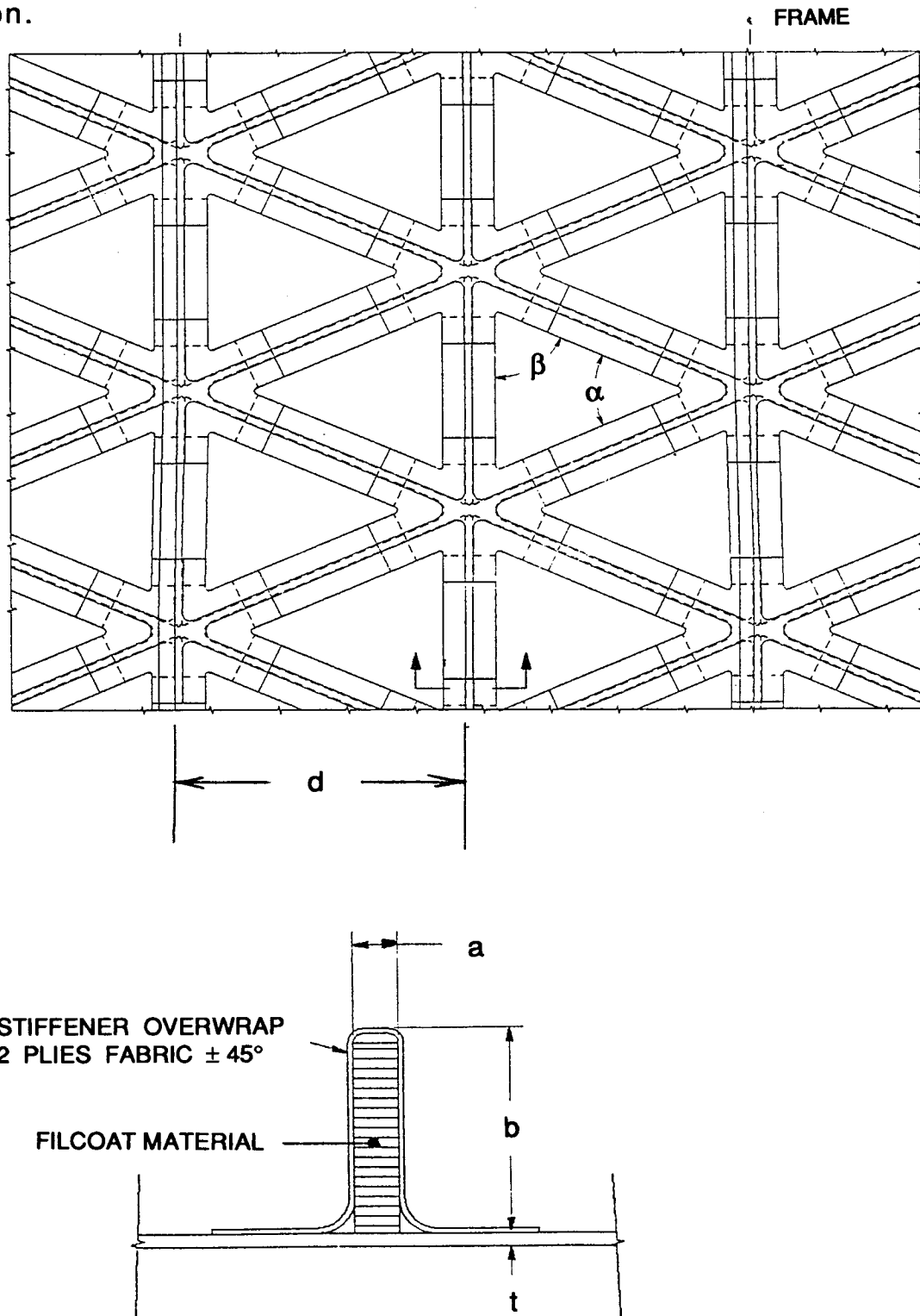

Figure 22, Geodesic Panel Geometry And Design Variables.

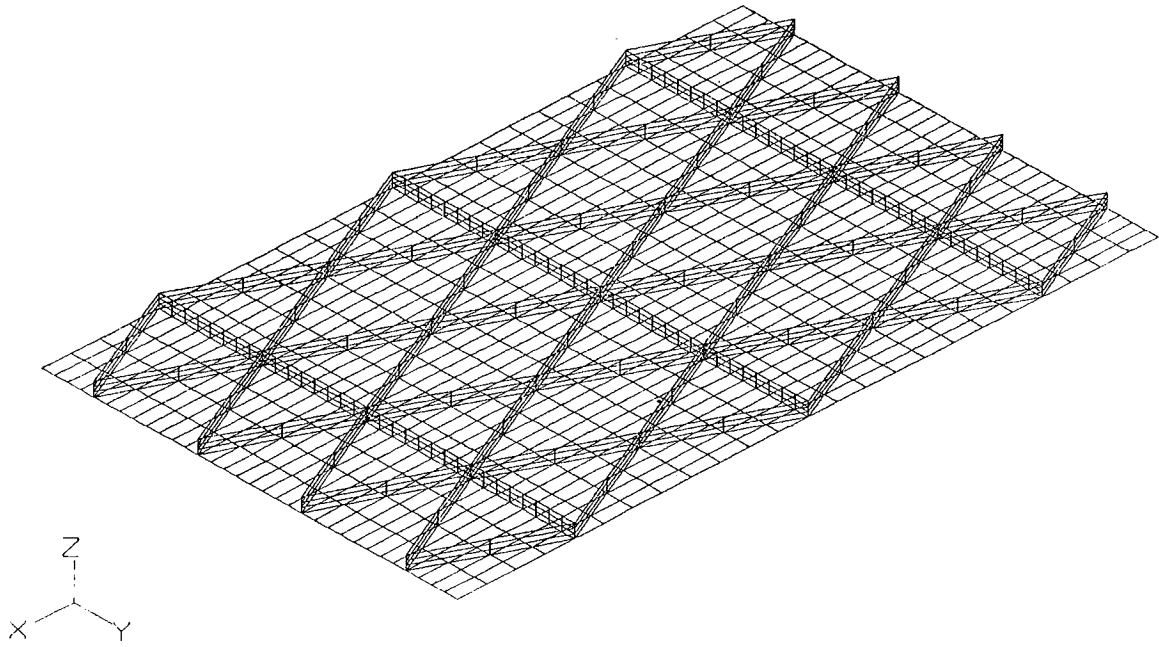

Figure 23, Geodesic Panel Finite Element Model Geometry.

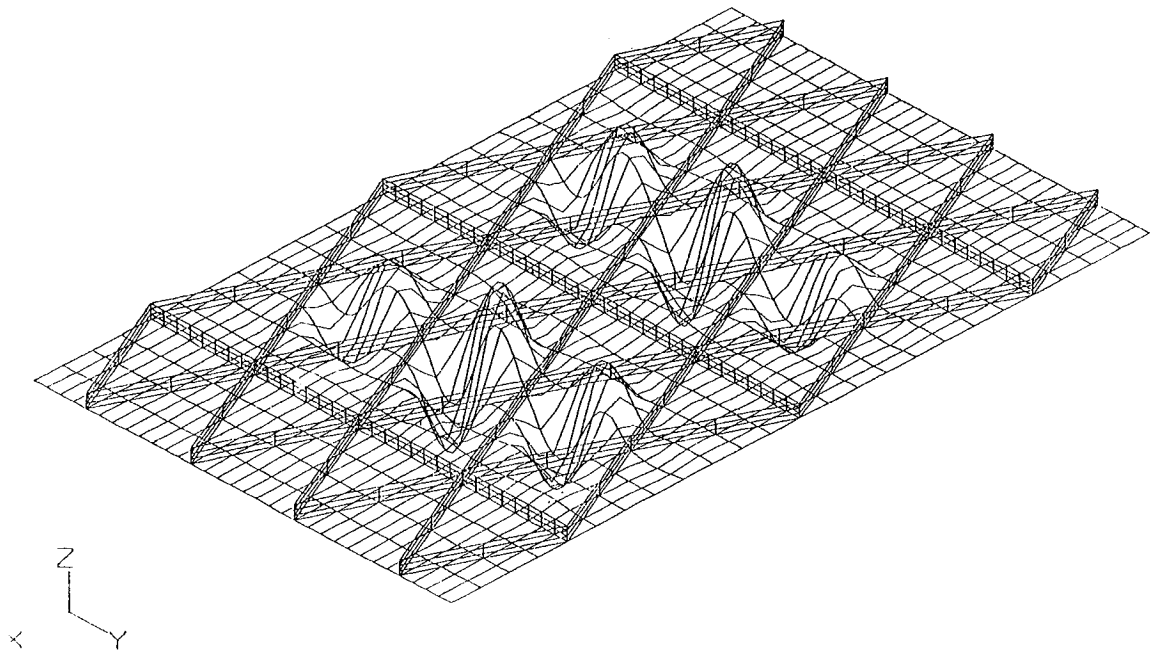

Figure 24, Geodesic Panel Buckled Mode Shape.

The loads used in the geodesic panel analysis are the same as for the Corrugated Sandwich Panels (Tables 10 and 11). For initial sizing purposes, the stiffeners are assumed to react all of the in-plane compression loads while the skin reacts the shear and pressure. The skin panels are allowed to buckle at 20% of ultimate load ($q_a / q_{cr} = 5.0$). As a damage tolerance criteria, the fuselage shell is sized to carry ultimate load with one bay missing.

The skins and over-wrap plies are made of toughened epoxy, with an intermediate modulus fiber. Mechanical properties used in the sizing analysis are:

$$\begin{aligned}
 E_1 &= 22.4 \text{ MSI} & \epsilon_t &= 6000 \text{ } \mu\text{in/in} \\
 E_2 &= 1.5 \text{ MSI} & \epsilon_c &= 4300 \text{ } \mu\text{in/in} \\
 G_{12} &= .59 \text{ MSI} & \gamma_{12} &= 12000 \text{ } \mu\text{in/in} \\
 \nu &= .30 & \rho &= .057 \text{ lb/in}^3 \\
 t_{\text{ply}} &= .0051 \text{ in/ply}
 \end{aligned}$$

The estimated* IM7 Filcoat material for the stiffeners has the following properties:

$$\begin{aligned}
 E_1 &= 11.0 \text{ MSI} & \epsilon_t &= 9800 \text{ } \mu\text{in/in} \\
 E_2 &= .9 \text{ MSI} & \epsilon_c &= 8800 \text{ } \mu\text{in/in} \\
 G_{12} &= .4 \text{ MSI} & \gamma_{12} &= 16000 \text{ } \mu\text{in/in} \\
 \nu &= .30
 \end{aligned}$$

* rule of mixtures for a 50/50 tape/syntactic core laminate

The minimum weight configuration resulted from the following set of values for the design variables (ref. Figure 22):

$$\alpha = 48^\circ, a = .25 \text{ in.}, b = 1.25 \text{ in.}, t = .07 \text{ in.}(14/57/29)$$

Stiffened Shell Fuselage

In this analysis, as in each of the other fuselage concepts, the frame spacing of 20 inches was retained. The stiffener configuration was selected to be a hat section with hat angle set at 60° for manufacturing considerations. The remaining dimensions - heights, thicknesses, spacings, etc..., were allowed to vary for optimization analysis.

The material system considered for this concept is a hybrid of Hercules AS4 - IM7 graphite fiber and Hercules 8552 toughened epoxy. This combination is believed to provide the best balance of mechanical properties, processibility and cost.

The panel was optimized for the design loads previously shown in Table 11 using the Lockheed PASCO program. The final dimensions resulting from this analysis are shown in Figure 25.

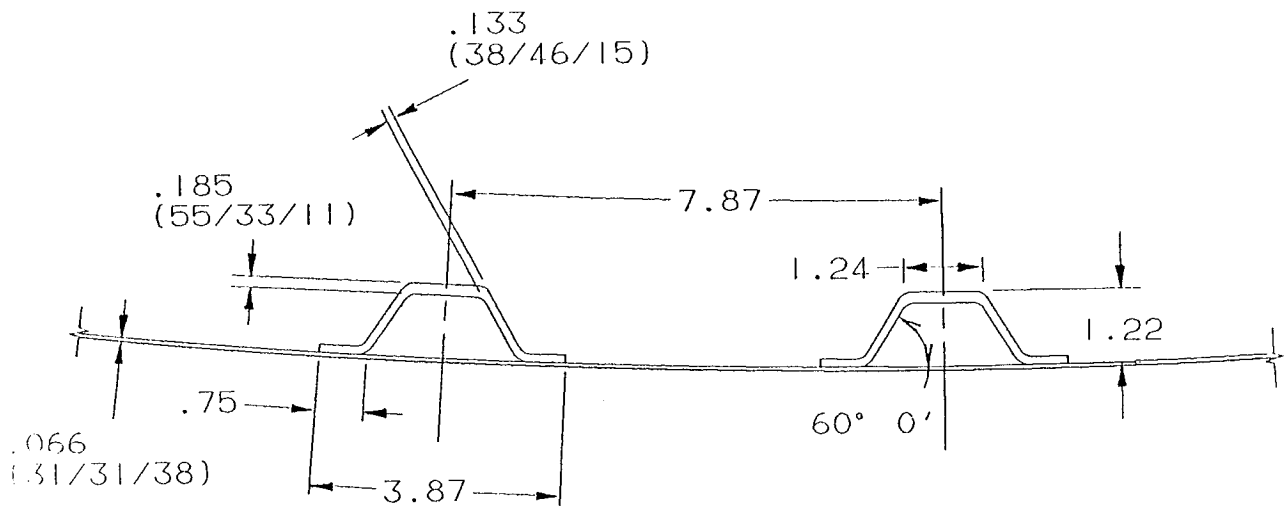

Figure 25, Stiffened Shell Fuselage Stiffener Configuration.

2.3.1 Sandwich Fuselage Concept

The sandwich fuselage concept, see Figure 26, was developed in order to take advantage of the structural characteristics of sandwich construction, (high stiffness/weight ratio). Some of the design features of the concept are; good load transfer between face sheets, redundant load paths, a smooth outer mold line (OML) with no fastener penetrations, relatively simple circumferential splices, resin transfer molded frames and tri-axial braided/pultruded triangular stiffeners. The sandwich construction was developed by placing the triangular tubes side-by-side and covering them with face sheets. The tubes serve two purposes, they act as 'core' material to separate the face sheets and also function as stringers providing longitudinal stiffness. This approach provides for a failsafe design through multiple load paths. One of the main benefits of the tubular core is that it allowed for excellent load transfer not only between the face sheets, but also between the circumferential frames and the outer skin. At the frame attach points the tubes have an added integral flange for frame attachment that provided a direct load path to the outer face sheet, see Figure 27, this flange also acts as a longeron providing additional stiffness. The frames are then attached to the skin with clips and mechanical fasteners. By using this approach no mechanical fasteners penetrate the fuselage skins which eliminates any pressure sealing requirements (for fasteners). Eliminating these fasteners reduced costs by eliminating the need for expensive countersunk fasteners and also provided for a smooth OML surface.

Braiding was eliminated in Section 2.2.4 from further consideration on the Braided Wing Concept, but could be considered for smaller components. The braiding process was selected for the manufacture of the basic triangular tubes and the flanged triangular tubes, because braiding is an automated and efficient process for the manufacture of relatively small components. Tri-axial braiding was selected in order to produce tubes with fibers in the 0° direction as well as $\pm 45^\circ$ direction. This allows the core to act as longitudinal stiffeners as well as typical "core" material (shear). In addition, the triangular tubes have "bulb" material, see Figure 28, to reduce the stress concentration at the corners and to eliminate a possible void area. The braided preforms made from prepreg tow are pultruded to advance the resin to a rigidized and stable shape. The "U" shaped inner skins are similarly pultruded from a braided preform. BASF's IM7/5225 towpreg has previously been successfully braided. Pultruding in-line with braiding can also be a very cost-effective

operation. Pultruding from dry braided or woven/stitched preforms with Shell 9310 type epoxy systems may be an alternate approach if pultruding braided prepreg is not feasible.

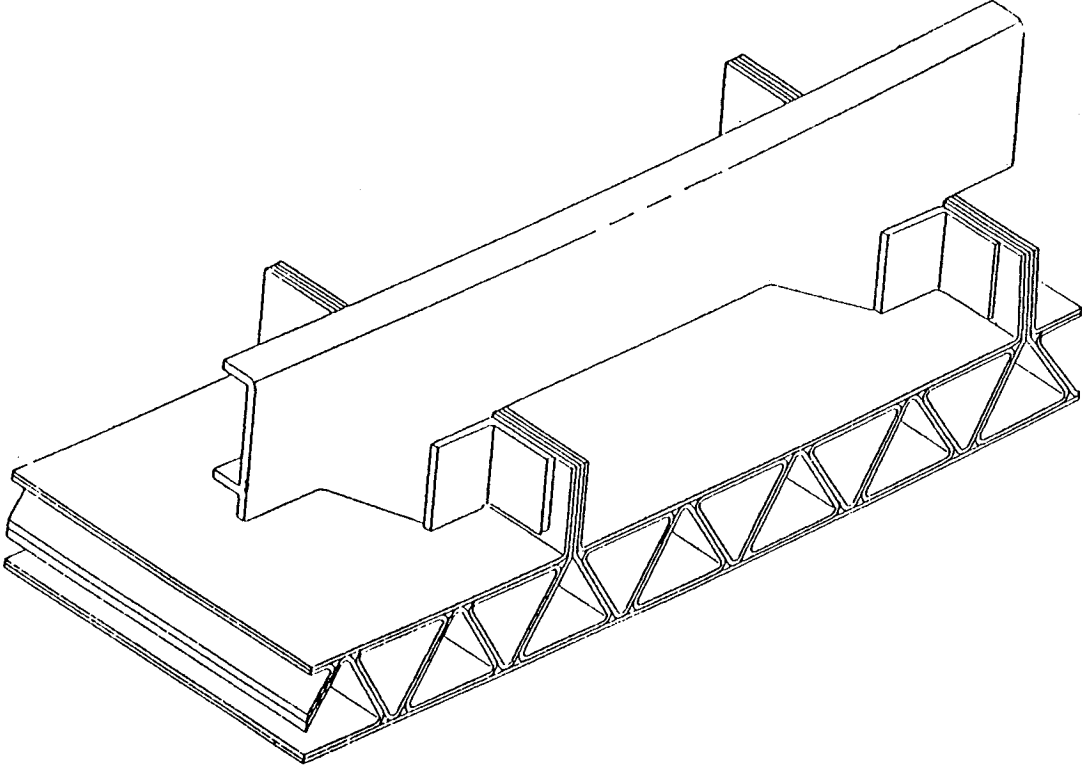

Figure 26, Sandwich Fuselage Concept.

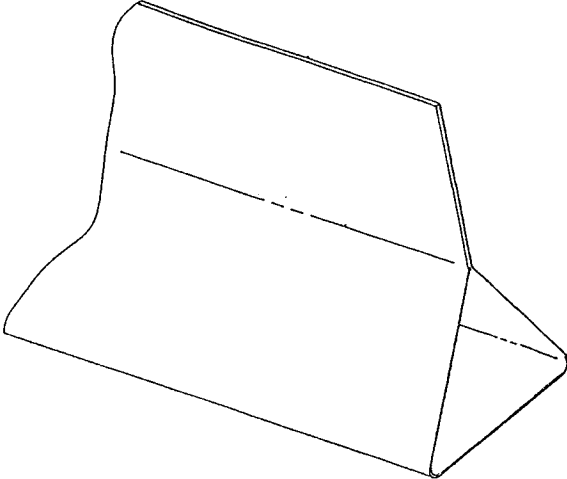

Figure 27, Core Element With Integral Flange.

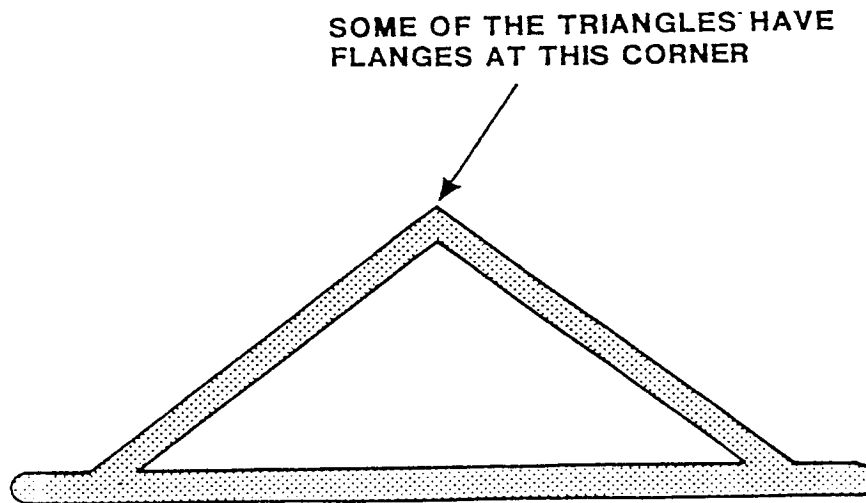

Figure 28, Schematic Of Tube With Filler At Corners.

Triangular mandrels for the braided tubes can be fly-away mandrels such as Rohacell polymethacrylimide (PMI) foam or another expanded polymer foam with similar properties that can withstand 100 psi and the 350°F cure autoclave cycle. Removable metal mandrels, silicone rubber mandrels with expansion holes are other options considered for fabrication.

The manufacturing plan proposed two options for the assembly of the fuselage skin and core. Option A uses a female tool and requires that the skin be automatic tape laid and cured separately, spraying a layer of adhesive on the skin and placing the triangular tubes side-by-side to form the first section between flanged tubes, see Figure 29. Adhesive is sprayed on all mating surfaces prior to final placement. Once the initial tubular sections are in position, the inner skin is added in-between the flanged tubes. This process is repeated to form the two fuselage sections that are subsequently bagged, cured and then joined to form the circular section. The mandrels are removed after fabrication.

Option B proposed a male tool and allowed the entire circumference to be made at once. One inner skin segment is placed in the tool and

sprayed with adhesive. The triangular tubes are then added in-between the flanged ends of the inner skin segment, see Figure 30. Integrally

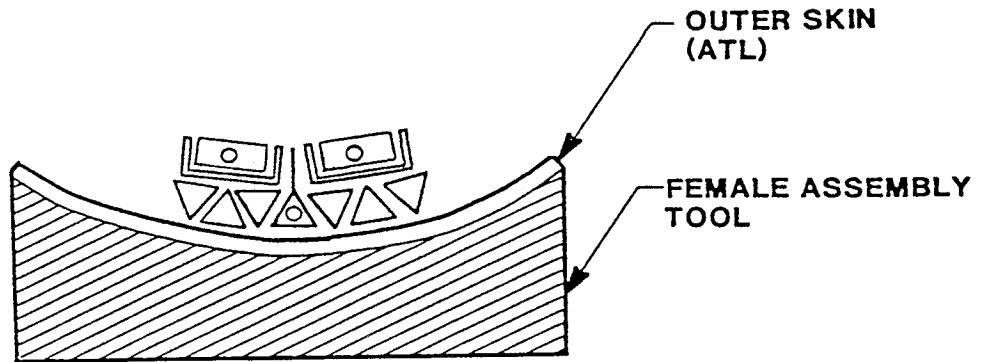

Figure 29, Female Tooling Concept.

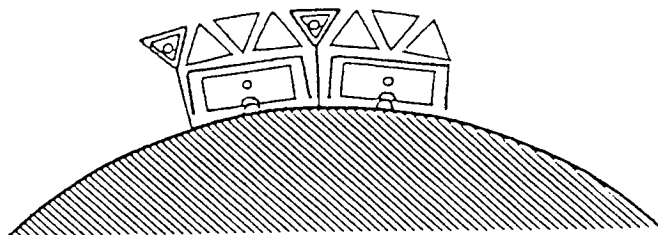
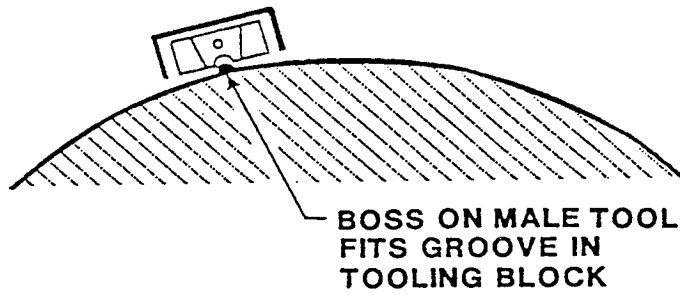

Figure 30, Male Tooling Concept.

flanged tubes are added at the ends of the skin segment and the the next inner skin segment is added. Again, note that a layer of adhesive is added prior to placing the tubes. This sequence is then repeated until all the inner skin segments and triangular tubes have been placed. The final operation is to automatic tape laying (ATL) the outer skin and bag and cure the assembly. The tooling concept for triangular and flanged tube fabrication may be similar to the one described for option A.

As discussed above, the sandwich fuselage design has resin transfer molded circumferential frames as shown in Figure 31. The final configuration of the frames, approaches an "F" frame configuration with integral shear tabs for attachment to the fuselage. This attachment is accomplished through angle clips fastened to the up-standing flange of the flanged triangular core tubes. This design approach allows the entire fuselage to be made with no fasteners penetrating the skin in-between the fuselage sections.

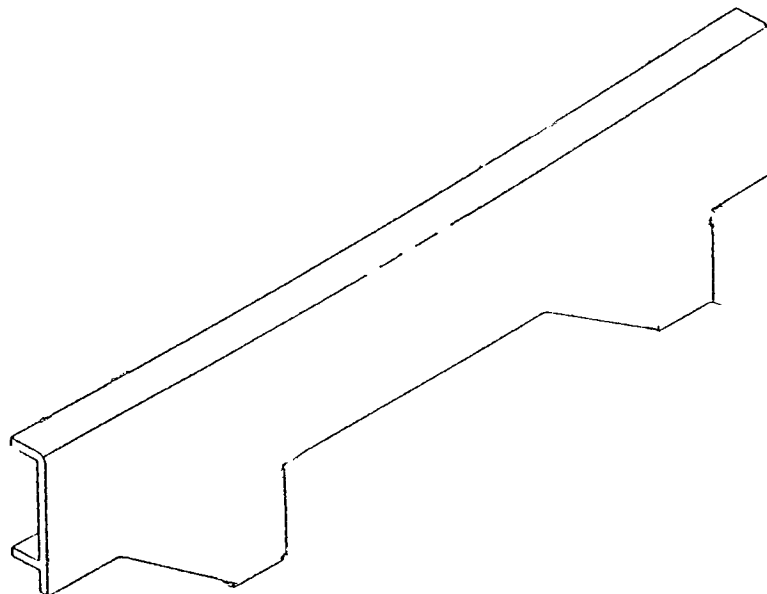

Figure 31, "F" Frame Configuration.

The only fuselage skin fastener penetrations are at the fuselage splice, as shown in Figure 32. Butt splices are used for the outer skins with the "core" and inner skin being cut back to transfer the loads into the outer skin. Additionally, the longerons are spliced through bath tub fittings which attach to the skin and the up-standing flange of the triangular tubes. The bath tub fittings are made by stretch forming from long discontinuous fiber thermoplastic sheet. The increased material cost of the thermoplastic material is traded-off in this case for the increased flexibility of the stretch forming process.

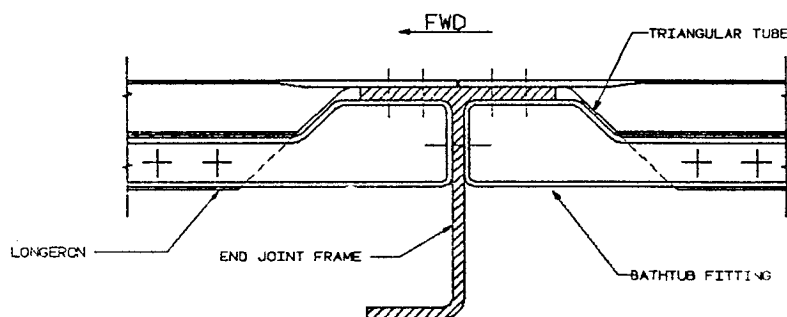

Figure 32, Proposed Fuselage Splice.

A summary of the materials chosen for each component along with the manufacturing method are shown below in Table 12.

Table 12, Material Selection And Fabrication Method For Sandwich Fuselage Concept.

MATERIAL SELECTION SUMMARY			
	MFG METHOD	MAT'L SELECTED	COMMENTS
TRIANGULAR TUBES	BRIADING	IM7/5225	TOWPREG
TRIANGULAR TUBES WITH FLANGE	PULTRUSION	IM7/5225	TOWPREG
STUFFERS	PULTRUSION	IM7/5225	TOWPREG
INNER SKIN CHANNEL	PULTRUSION	IM7/5225	TOWPREG
OUTER SKIN	ATP/ATL	IM7/5225	TOWPREG
FRAME	RESIN FILM INFUSION	IM7 PREFORM/8552 RESIN	AUTOCOMP
BATHTUB FITTINGS	MATCHED MOLD FORMING	ALIGNED DISCONTINUOUS PEI	

2.3.2 Geodesic Fuselage Concept

The geodesic fuselage concept, shown Figure 33, features a completely co-cured fuselage assembly with continuous helical stiffeners, excellent damage tolerance characteristics and no fastener penetrations through the pressure shell. Circumferential stiffeners were added to allow for frame attachment. Note, the circumferential stiffeners are discontinuous in order to allow the helical stiffeners to be continuous

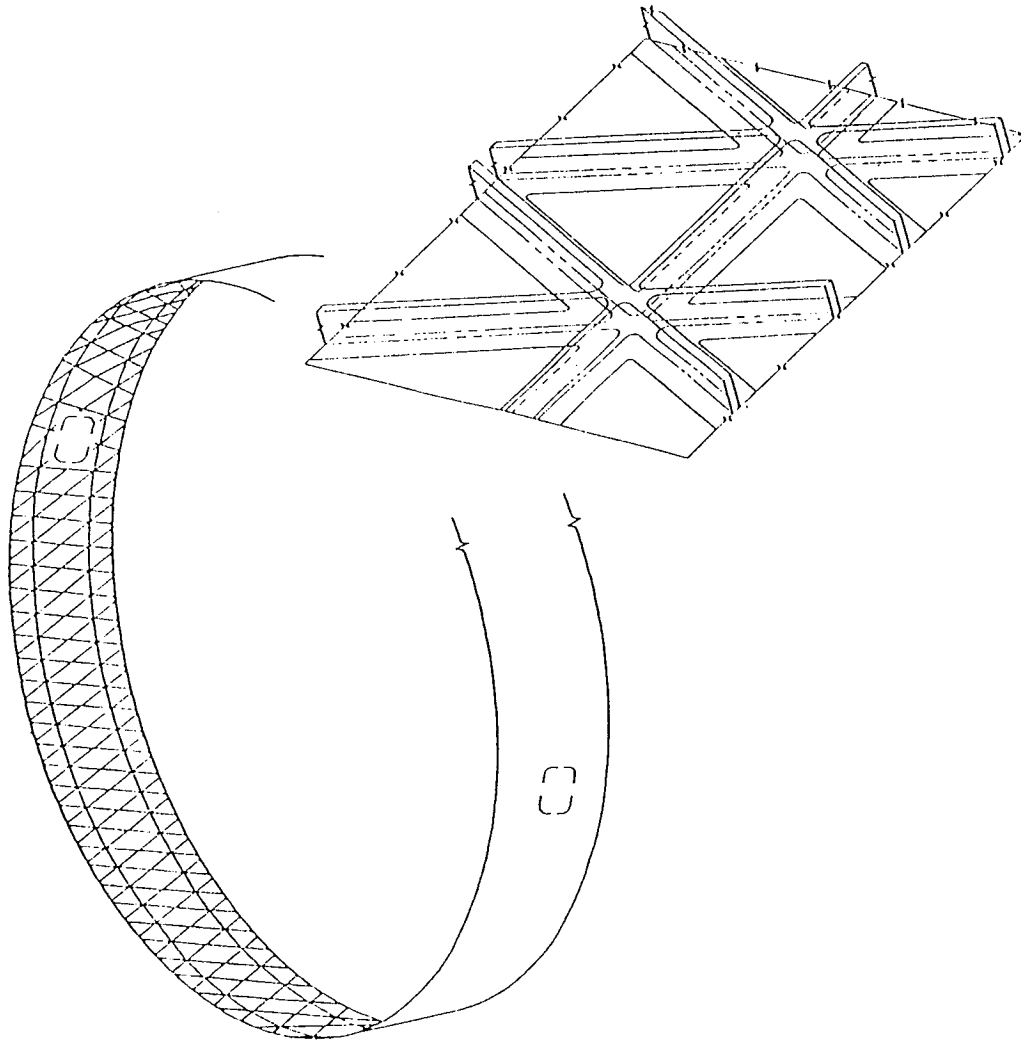

Figure 33, Geodesic Fuselage Concept.

around the fuselage section and permit the use of automated manufacturing processes such as, automated tape laying. Helical stiffeners are over-wrapped to assist in stabilizing the stiffeners and to provide a shear path to the skin.

The geodesic fuselage concept takes advantage of a Lockheed/Hysol developed material system (Filcoat) composed of a layer of graphite/thermoset prepreg and a layer of syntactic material. These are joined to form a two layer "tape" ideally suited for the manufacture of over-lapping structures. In forming the helical stiffeners the tape is laid down in an over-lapping layer-by-layer manner causing a doubling of the thickness at the intersection/node points. This doubling of the thickness at the intersection normally requires that the material be spread-out as it is being laid-up to eliminate the doubling effect or that one layer be discontinuous. Using the Filcoat material eliminates the doubling of thickness effect by allowing the syntactic material to be squeezed out at the intersection to form a solid layer of graphite/epoxy. The construction of the stiffener section between nodes is an alternating layer of Gr/Ep and syntactic material, see Figure 34.

The main drawback of composite geodesic designs is that they are very difficult to join. Splicing fuselage sections with geodesic stiffeners is complicated by, the large number of stiffeners, the tolerances associated with the stiffener locations and the lack of tapering capability in the stiffener section. This is one major area of concern with the geodesic fuselage that was to be investigated further in the "Structural Concept Development" part of task I. Another concern with the geodesic concept is the requirement that the stiffeners be covered (over-wrapped) which greatly increases manufacturing complexity and costs. Due to the lack of fiber continuity at the stiffener/skin interface, over-wrapping of the stiffeners was needed to increase the bond area between the stiffener and the skin.

Manufacturing of the stiffener over-wraps is accomplished by pultruding from prepreg and cutting the pultruded segments to proper size and placing the over-wraps into recesses in the fuselage mandrel. At the intersection points, see Figure 35, the stiffener over-wraps extend and are made from a woven preform which is resin transfer molded, and then placed in the fuselage mandrel for subsequent co-bonding.

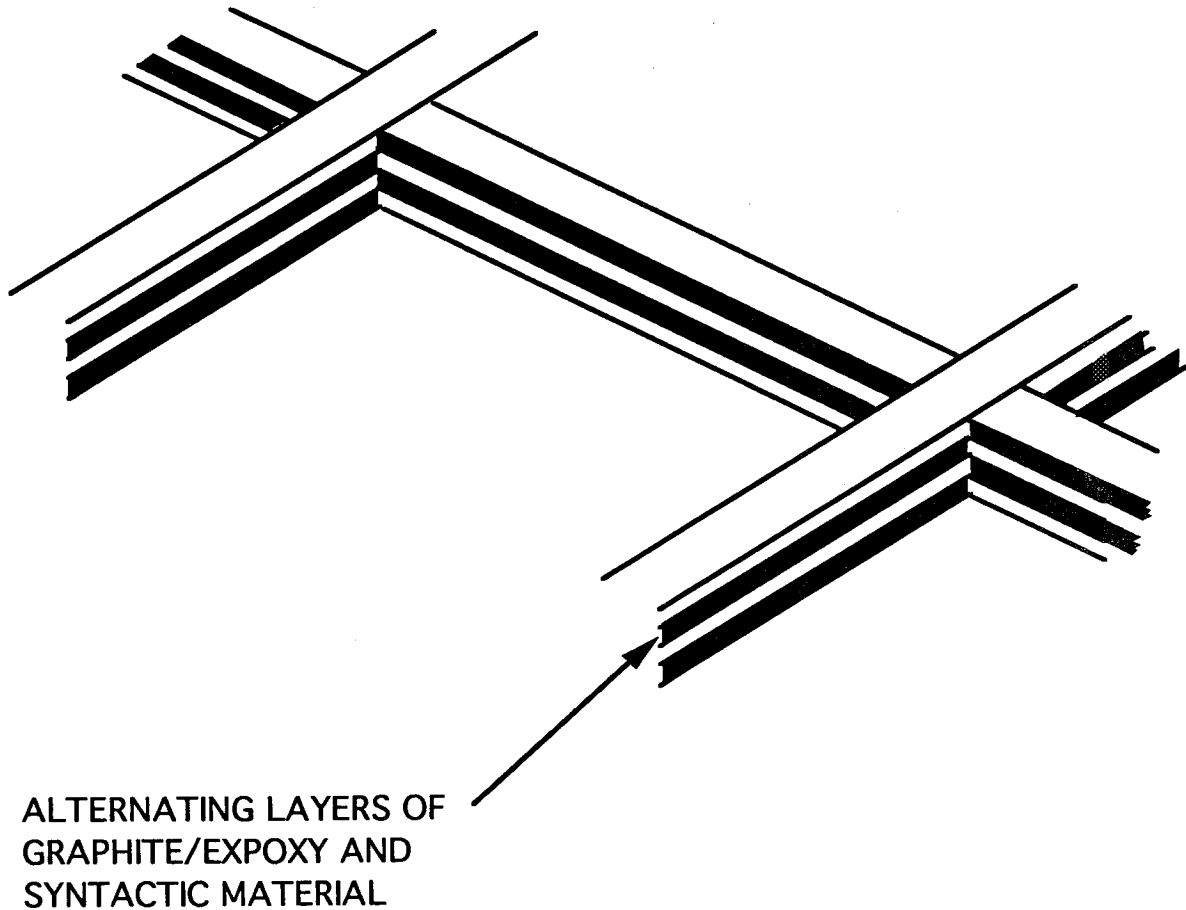

Figure 34, Stiffener Build-up With Filcoat Material,
(Two Plies Shown).

As previously discussed, the circumferential stiffeners are discontinuous at the intersection points. The manufacturing of circumferential stiffeners can best be accomplished by curved pultrusion of a fiber preform or resin infusion of a stitched preform. Curved pultrusion has been successfully demonstrated by pultrusion/pull-forming. Both processes allow B-staging or advancing the resin to a rigidized state that can be laid into the fuselage tool for final assembly. The helical stiffeners are blade shaped stiffeners and are made by tape placing the Filcoat material into the recesses of the fuselage mandrel following the installation of over-wrap components (See Figure 36).

As the helical pattern is developed the material is laid-up to form blade stiffeners with the tape overlapping from two directions at the intersections. Again, this overlapping problem is alleviated by the flowability of the syntactic half of the tape. During the cure cycle the syntactic material softens and flows leaving only the Gr/Ep material at the intersections.

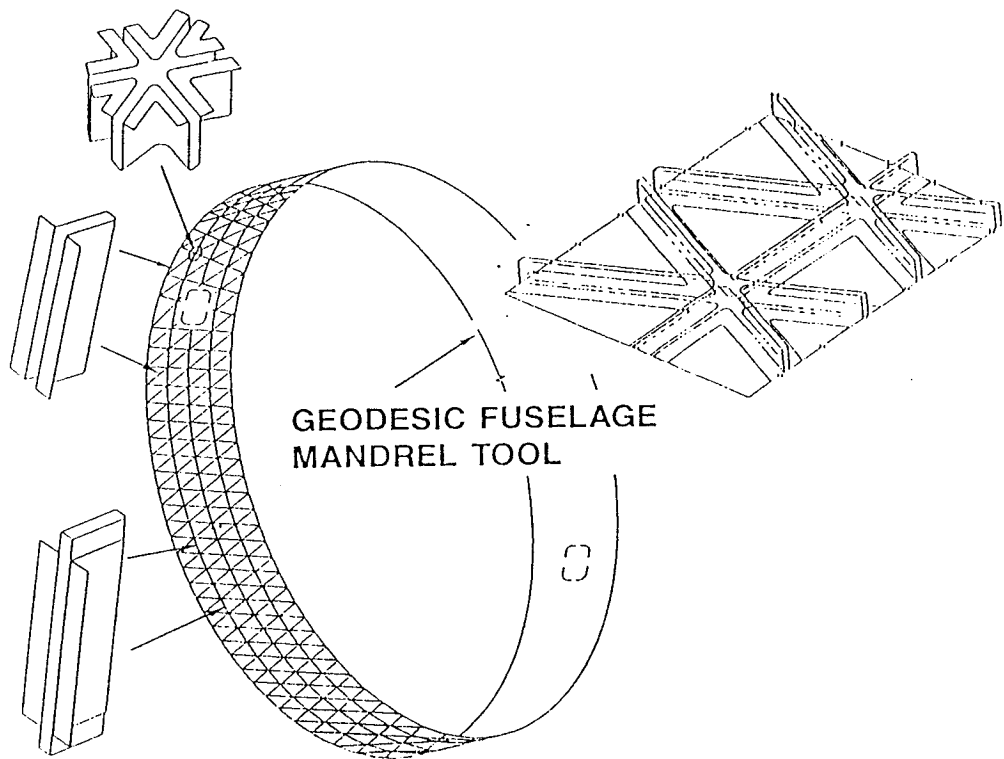

Figure 35, Intersection Point Covers.

After all the components have been placed into the recesses of the fuselage tool and the helical stiffeners tape laid, the outer skin is tow placed and a caul sheet is placed over the skin. The entire assembly is then envelope bagged and cured.

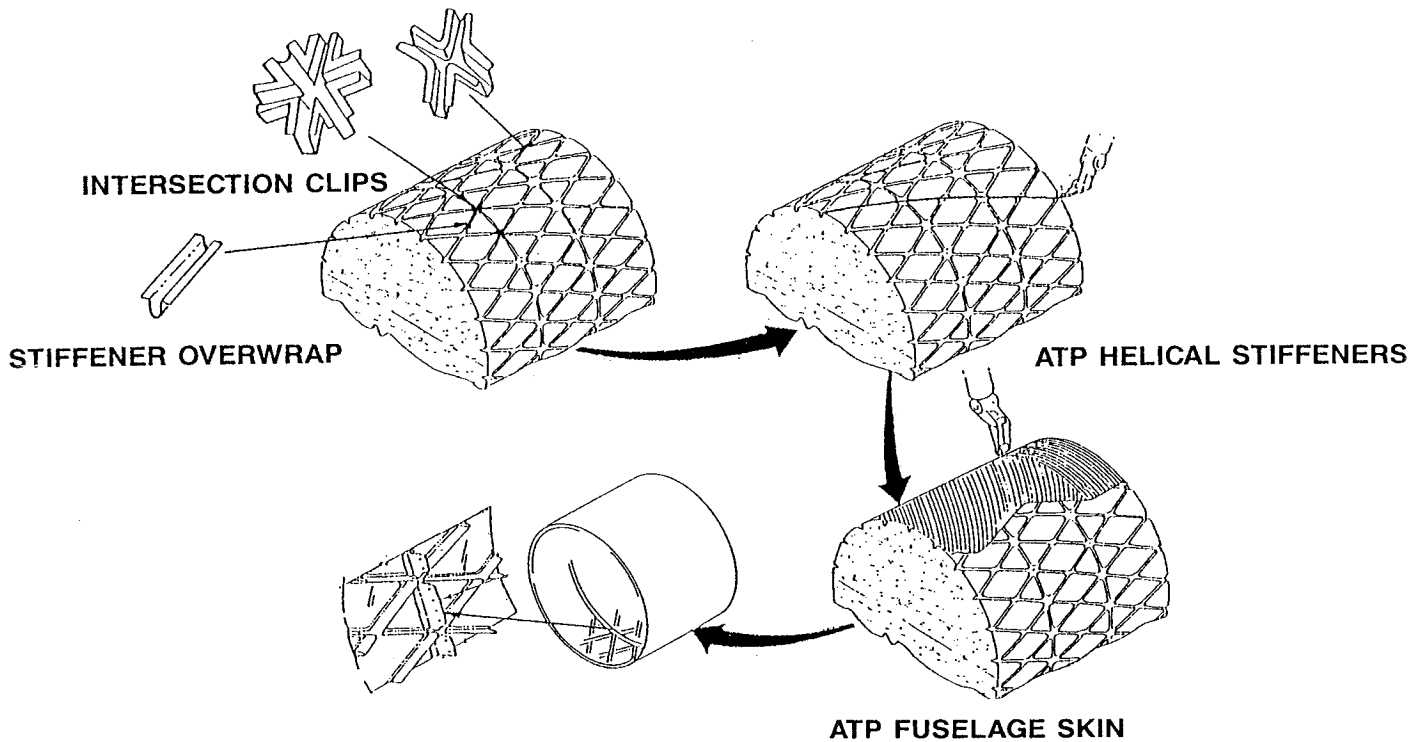

Figure 36, Fabrication Sequence.

The circumferential frames for the geodesic fuselage is a "F" configuration with cutouts at the helical stiffener intersections. The Xerkon autocomp molding process was selected for the manufacture of the circumferential frames. A dry fiber stitched preform and resin film are placed into the Autocomp matched mold and the resin is infused into the layers of material. The "F" frames are then mechanically fastened to the circumferential stiffeners of the fuselage on final assembly.

A summary of the materials chosen for each component along with the manufacturing method are shown below in Table 13.

2.3.3 Stiffened Shell Fuselage Concept

The stiffened shell fuselage concept, shown in Figure 37, was developed as a fully automated concept to reduce overall manufacturing

**Table 13, Material Selection And Fabrication Method
For Geodesic Fuselage Concept.**

MATERIAL SELECTION SUMMARY			
	MFG METHOD	MAT'L SELECTED	COMMENTS
STIFFENED COVERS	PULTRUSION	IM7/5225	TOWPREG/SLIT TAPE
INTERSECTION CLIPS	RESIN FILM INFUSION	IM7 PREFORM/8552 RESIN	AUTOCOMP
ISOGRID STIFFENERS	ATP	IM7/5225	TOWPREG/FILCOAT
FUSELAGE SKIN	ATP	IM7/5225	TOWPREG
FRAME	RESIN FILM INFUSION	IM7 PREFORM/8552 RESIN	AUTOCOMP

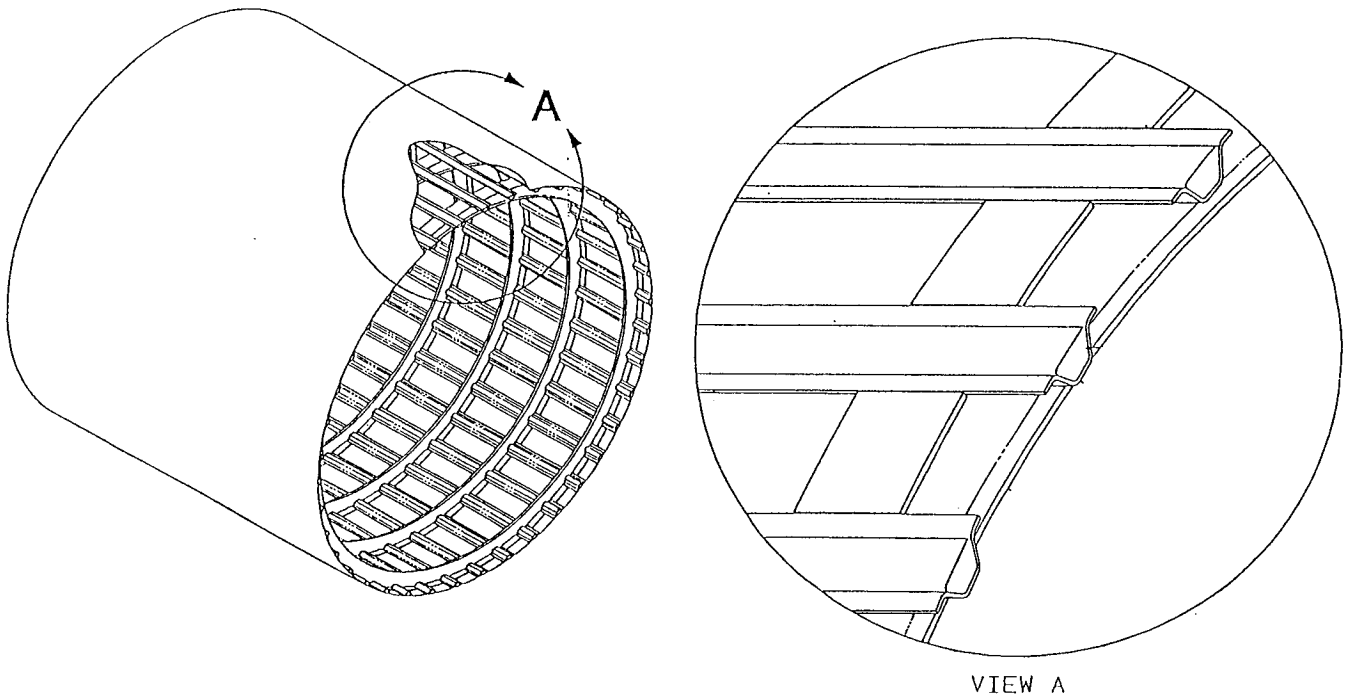

Figure 37, Stiffened Shell Fuselage Concept.

costs and consisted of an outer skin, open section hat stiffeners and "J" section circumferential frames. Features of the concept includes; continuous hat pultruded stiffeners, good damage tolerance characteristics through redundant load paths and resin film infused (RFI) frames. All of these features combine to form a relatively simple design ideally suited to co-curing. During conceptual development hat stiffeners

were selected to produce a low-cost design. This had the beneficial effect that the stiffeners could be made by braiding and pultrusion (two low-cost manufacturing processes). Another main benefit was the ability to reduce the total number of stiffeners required. An added feature of the hat stiffeners is that they are more stable than other stiffening concepts, such as blades. Hat stiffeners generally do not require the addition of clips to stabilize the stiffener at the frame intersections.

The manufacturing plan calls for the "J" frames to be a textile preform made by the braiding or knitting/stitching processes. These preforms can be fabricated either by resin transfer molding or resin infusion molding processes. (See Figure 38 for the basic tooling approach.) Resin infusion processes allow a controlled B-staging or advancing of a resin for a subsequent co-cure on final assembly of the shell-stiffened fuselage section.

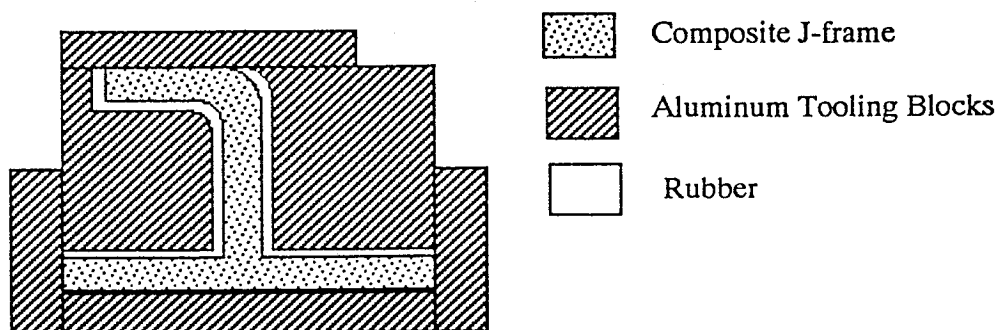

Figure 38, Cross-Section Of The Tooling For Infusing The "J" Preform With Resin.

The hat stiffeners are open sections and can be formed from tri-axially braided material. The hat stiffened preforms are then pultrudable to a rigidized B-stage form to be co-cured in the final assembly. The braiding process allows the tailoring of properties by the addition of 0° fibers in the cap areas for structural efficiency. Pultrusion of BASF-5225 prepreg has been carried out under controlled conditions. Another approach is that the dry preform can be pultruded using epoxy resins like Shell 9310.

Prior to the insertion of the frame into the fuselage assembly tool, the "mouse holes" for the hat stiffeners must be cut into the frame and plugs inserted to fill the void. The hat stiffeners and the frames are then placed with teflon support mandrels in the recesses of the fuselage assembly tool, see Figure 39. Teflon mandrels are easily removable after final assembly and provide sufficient pressure during molding through thermal expansion. The outer skin is then filament wound over the tool and stiffener assembly. The entire section is then bagged and cured in an autoclave for final assembly. As discussed above, the use of hat stiffeners allows the omission of shear-ties to the frame. This also allows the fuselage tool to be simplified, further reducing tooling assembly costs. Co-curing the fuselage shell eliminates the use of fasteners and reduces assembly steps/costs.

A summary of the material systems for each component along with the manufacturing method are shown below in Table 14.

2.4 Cost Trade Studies

This section summarizes the estimated costs for the advanced design concepts based on design packages received from the D/M I team, and compares them to baseline metallic structures. Cost methodology and assumptions are also included.

2.4.1 Cost Estimating Rules & Methodology

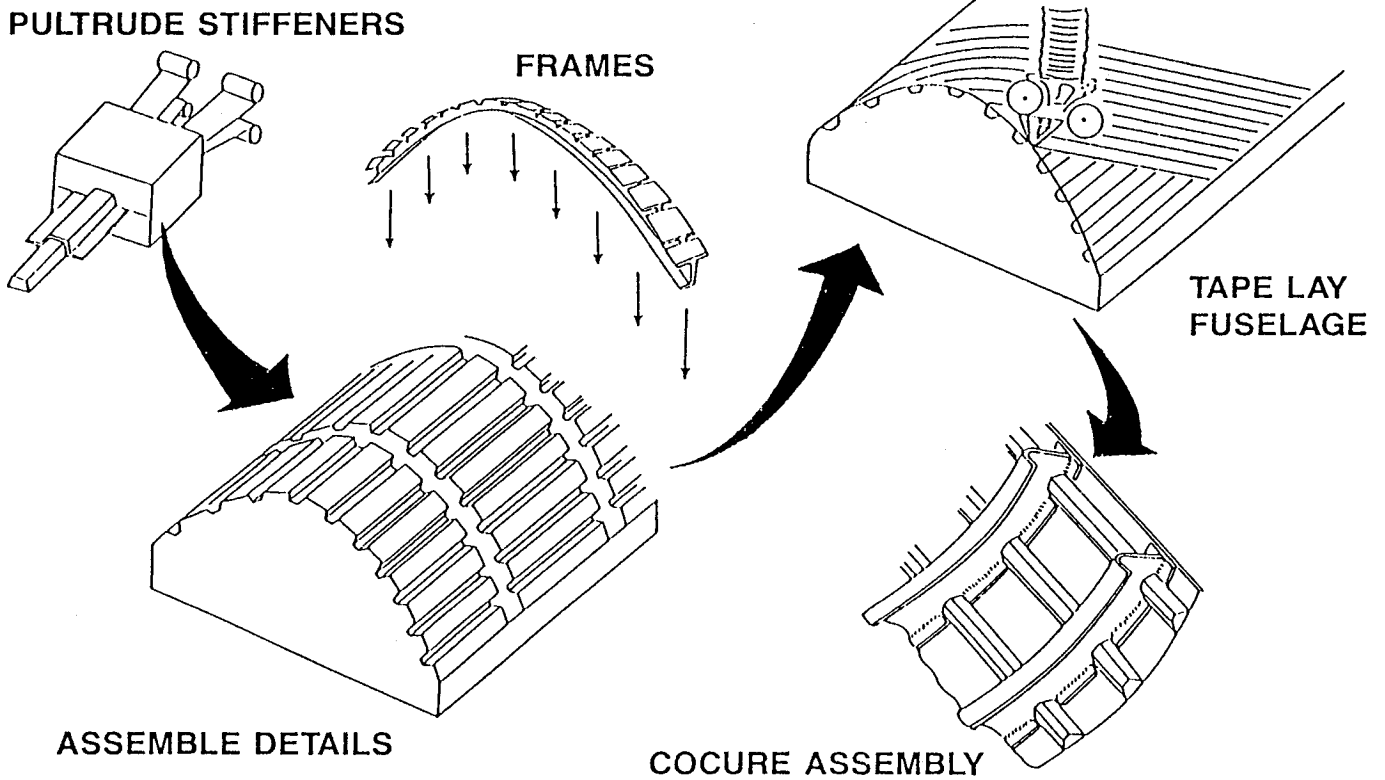

Figure 39, Final Assembly Sequence.

Table 14, Material Selection And Fabrication Method For Stiffened Shell Concept.

MATERIAL SELECTION SUMMARY			
	MFG METHOD	MAT'L SELECTED	COMMENTS
SKIN	ATP	IM7/8552	TOWPREG/SLIT TAPE
HAT STIFFENERS	PULTRUSION	AS4-IM7/8552	PREPREG
FRAMES	RESIN FILM INFUSION	IM7 PREFORM/5225 RESIN	B-STAGED

The cost estimates developed are based on 300 aircraft, with a lot size of 24, and a production rate of not more than 10 aircraft per month. The estimates assume current state-of-the-art methods and procedures with the exception of any existing limitations due to size. All costs are based on 1990 constant year dollars.

The methodology used on the ACT program is a combination of a variety of methods each depending on the design concept and manufacturing plan associated with the particular concept. All use standard hours as the basis for recurring manufacturing labor and unit material costs as the basis for material cost. Other recurring costs, such as recurring engineering, quality, and tooling are factored from the manufacturing costs based on historical data. After the determination of the time standards for each part or assembly, they are converted to estimated actual hours through the use of variance factors and learning curves. The labor hours are converted to dollars by the application of the appropriate labor rate. The material cost is added after applying material burden and escalation factors. Quality and sustaining engineering and tooling are included to determine the total recurring cost.

2.4.2 Cost Comparisons and Contributors

2.4.2.1 Wing Design/Manufacturing Concepts

Cost estimates developed for the baseline L-1011 wing box and the advanced design/manufacturing concepts are summarized in Figures 40 through 43. Shown in these figures are a breakdown of the wing costs by component along with the cost distribution by cost element for each concept.

Modular Wing Box Concept

As a result of fewer components during assembly, lower stringer costs are indicated, as well as, reduced assembly costs. The upper and lower surface assemblies are the highest cost contributors due generally to their size and co-curing of multiple rib caps and stringers. The rib web costs assume thermoplastic tape compression molded to the part configuration. The results of a trade study comparing alternatives of

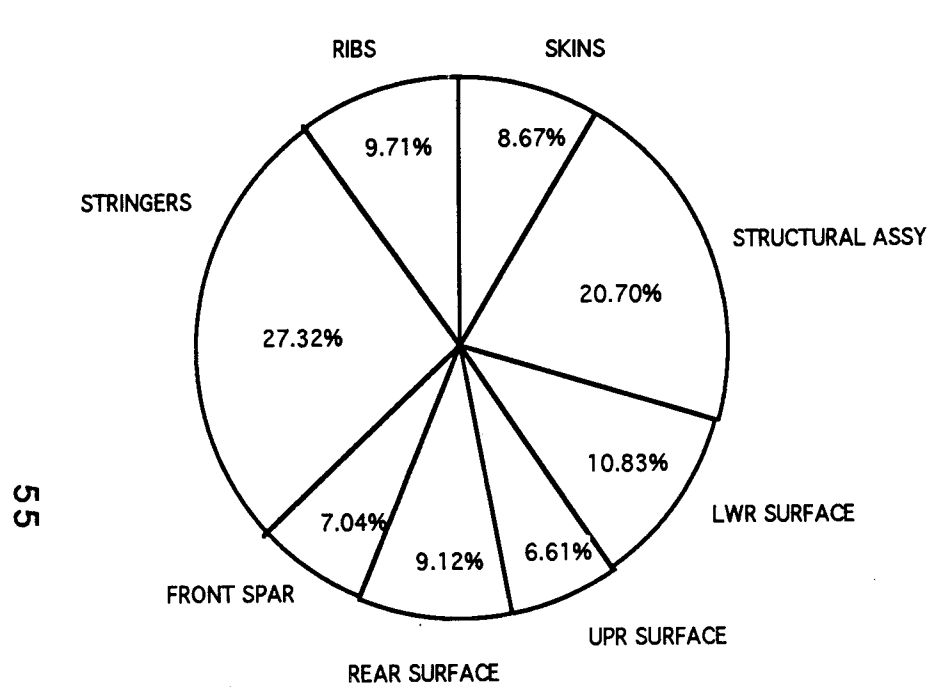

Component Cost Breakdown

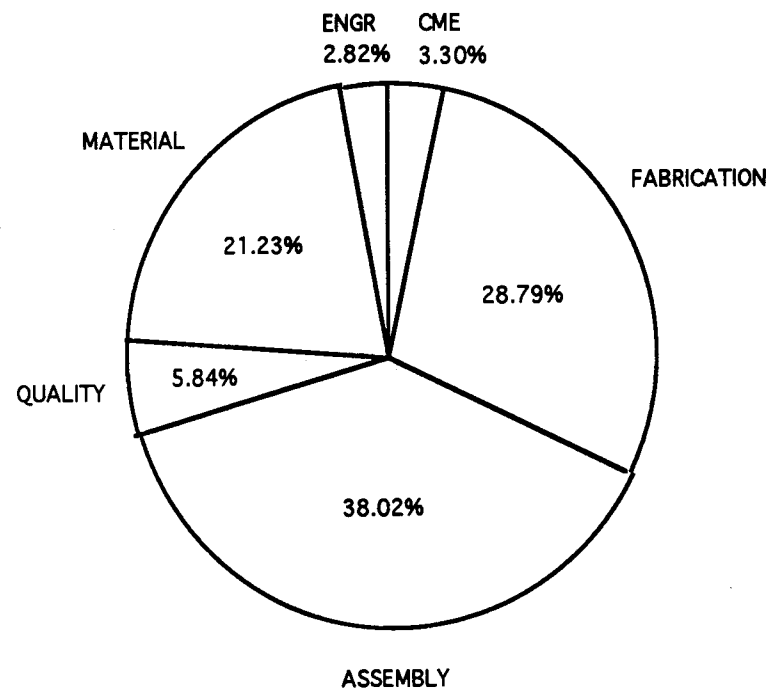

Cost Element Distribution

Figure 40. L-1011 Wing Box

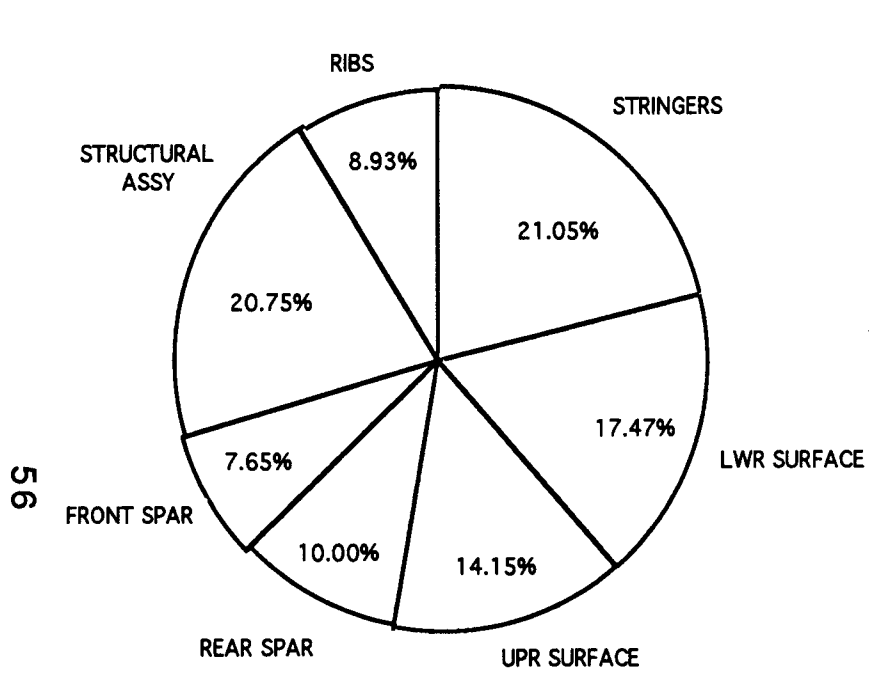

Component Cost Breakdown

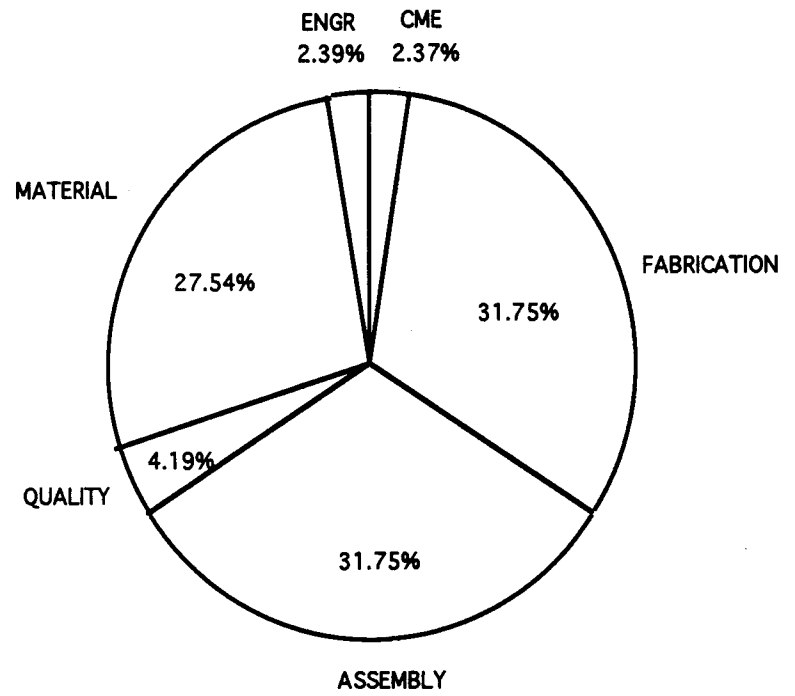

Cost Element Distribution

Figure 41. Modular Wing

57

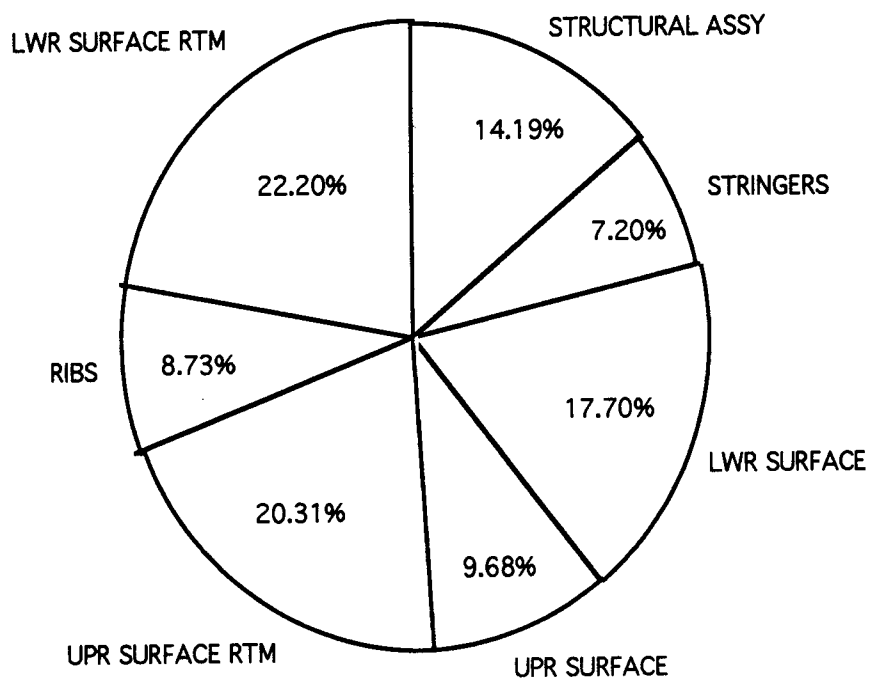

Component Cost Breakdown

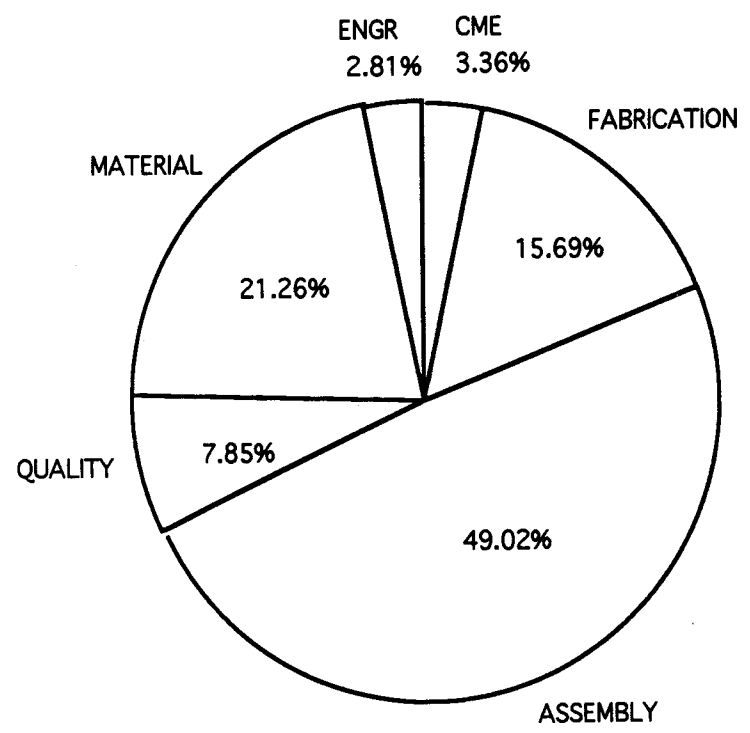

Cost Element Distribution

Figure 42. RTM Wing Box

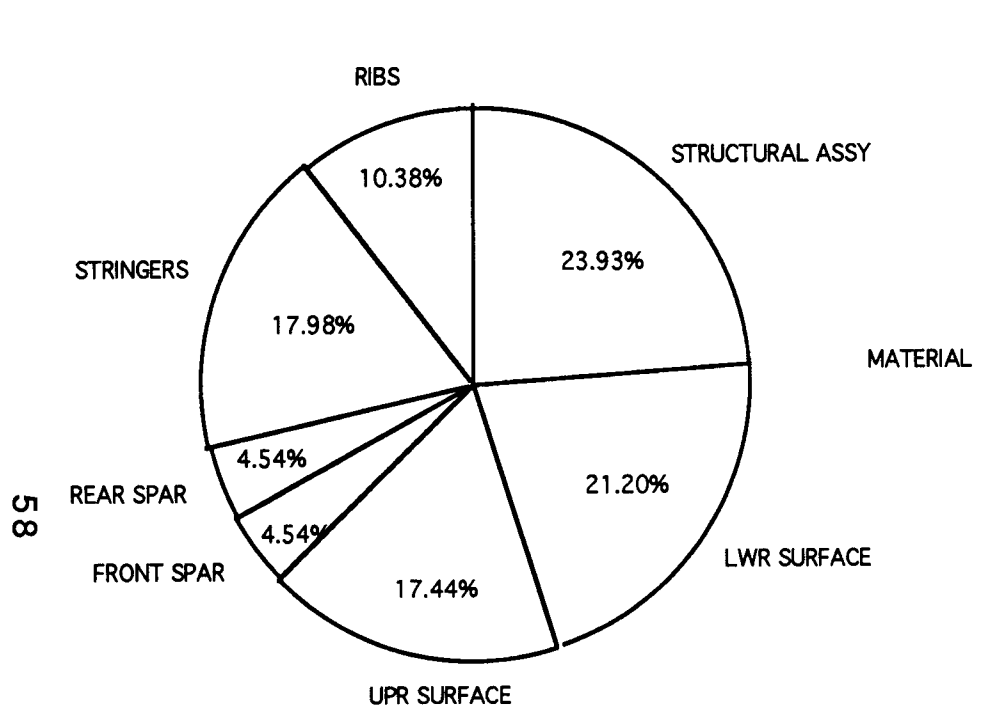

Component Cost Breakdown

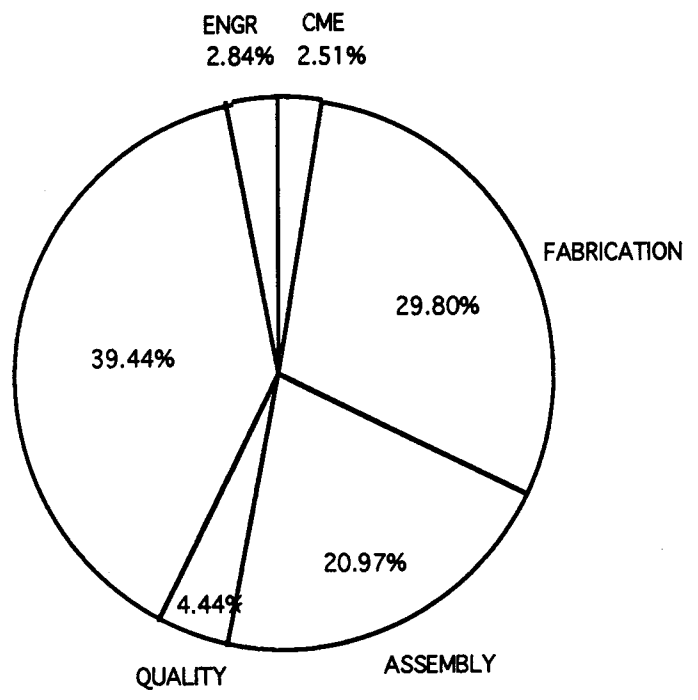

Cost Element Distribution

Figure 43. Tow Placement Wing Box

thermoplastic Quadrax material and graphite epoxy fabric are shown in Table 15. One of the risk items of this concept concerns how accurately each part can be located to insure a good bond during co-curing. Even though expensive, the cost estimate assumes accurate fit and therefore a successful joint.

Table 15, Rib Concept Cost Comparison.

THERMOPLASTIC TAPE (COMPRESSION MOLDED)	\$268,364
THERMOPLASTIC QUADRAX	389,612
GRAPHITE EPOXY FABRIC	121,773

Resin Transfer Molded Concept

The high cost contributor identified in this concept is the placement of the assembled wing cover preform into the RTM tool. Multiple tools are assumed for accurate dimensional control as the resin is injected. Stitching costs could possibly be understated since the number of stitches assumed are considered only sufficient to hold the material together.

Automatic Tow Placement Concept

An overall cost reduction of 24% is indicated over the baseline metallic box structure. Again, the high cost contributor is the placement/assembly of the wing skin components. A risk consideration involves the credibility of extending an automated placement process to a structure of the size being considered.

2.4.2.2 Material Cost Sensitivity Study

A cost of 40 dollars per pound for graphite composite material was assumed. The cost estimate for each advanced design/manufacturing concept was iterated by adjusting the base material through a range from 20 to 65 dollars per pound. The results are depicted in Figures 44

through 46. As shown in these figures, material cost variances have a very significant impact on the cost of composite structures.

2.4.2.3 Wing Spar Trade Study

A trade study on alternate spar concepts was conducted and the results are shown in Table 16. The "C" channel configuration is relatively less than the "I" beam configuration for all concepts considered. In all cases, the "C" channel consists of essentially one half of the lay-ups required for the "I" channel.

2.4.2.4 Fuselage Design/Manufacturing Concepts

Cost estimates for the baseline fuselage component and the advanced design/manufacturing concepts developed are summarized in Figures 47 through 50. Cost distribution by component and cost element is shown for each concept.

Cost Benefits/Drivers

Sandwich Concept - Costs are moderated through automated fabrication methods. However, cost benefit is nullified due to added number of parts and the associated increased assembly time.

Geodesic Concept - Cost benefit is achieved from the commonality of details parts. High cost is due to a significant increase in the number of parts being fabricated and assembled.

Stiffened Shell Concept - This concept offers a significant improvement due to reduced part count through co-cured assemblies and elimination of fasteners. Cost is increased by complexity of tooling required.

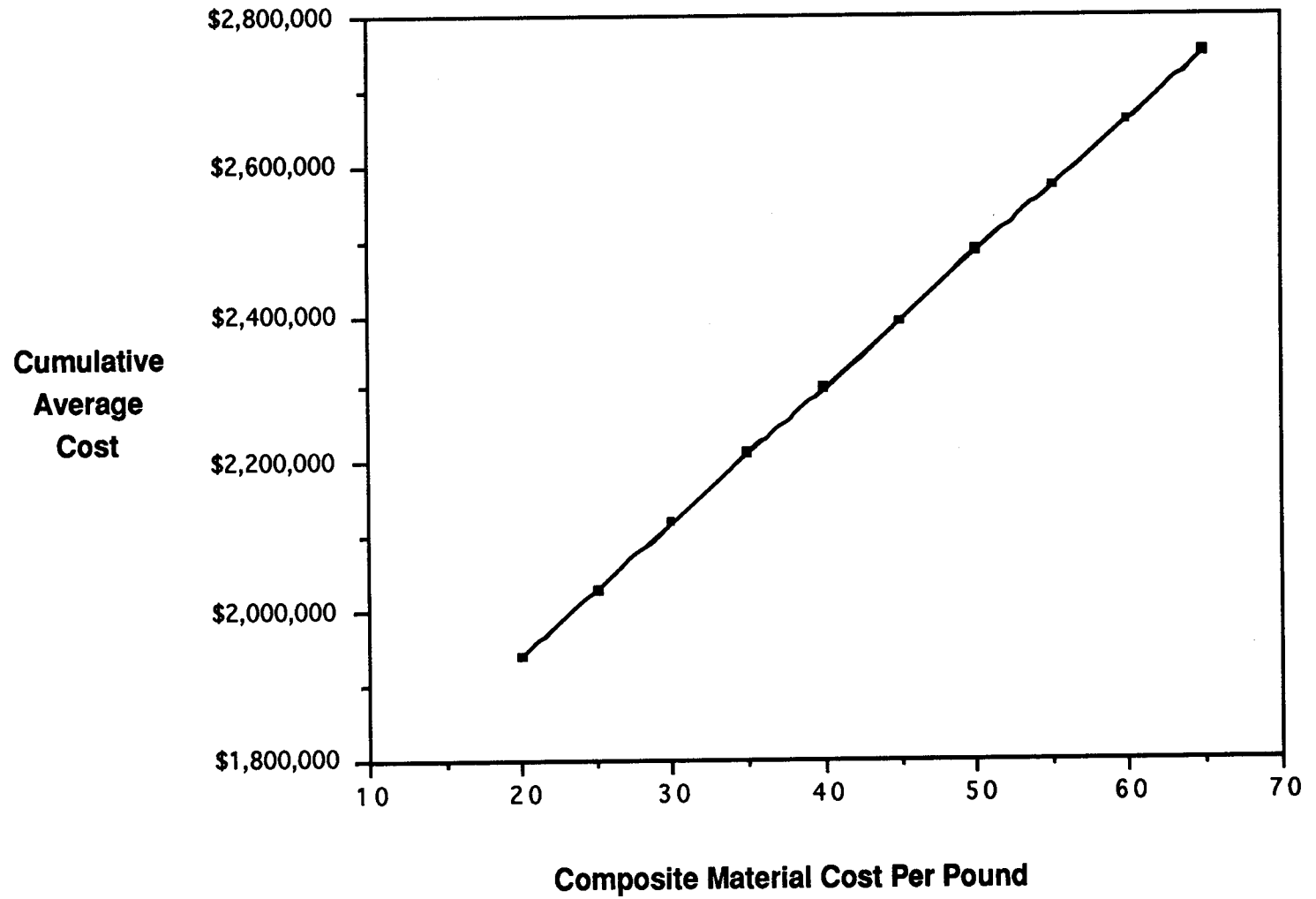
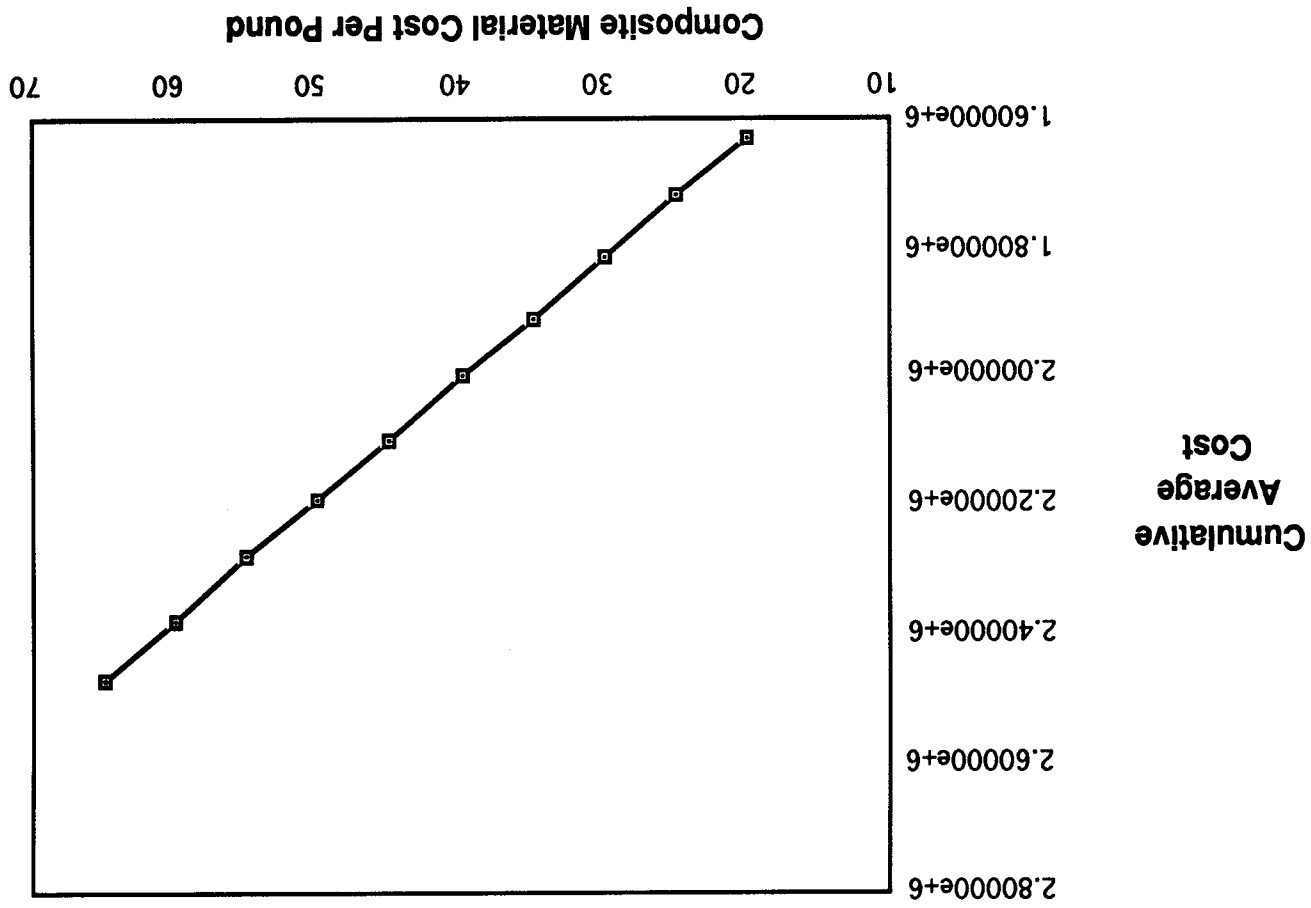

Figure 44. Modular Wing Design Concept Composite Material Cost Sensitivity Study

Figure 45. Automatic Tow Placement Design Concept
Composite Material Cost Sensitivity Study



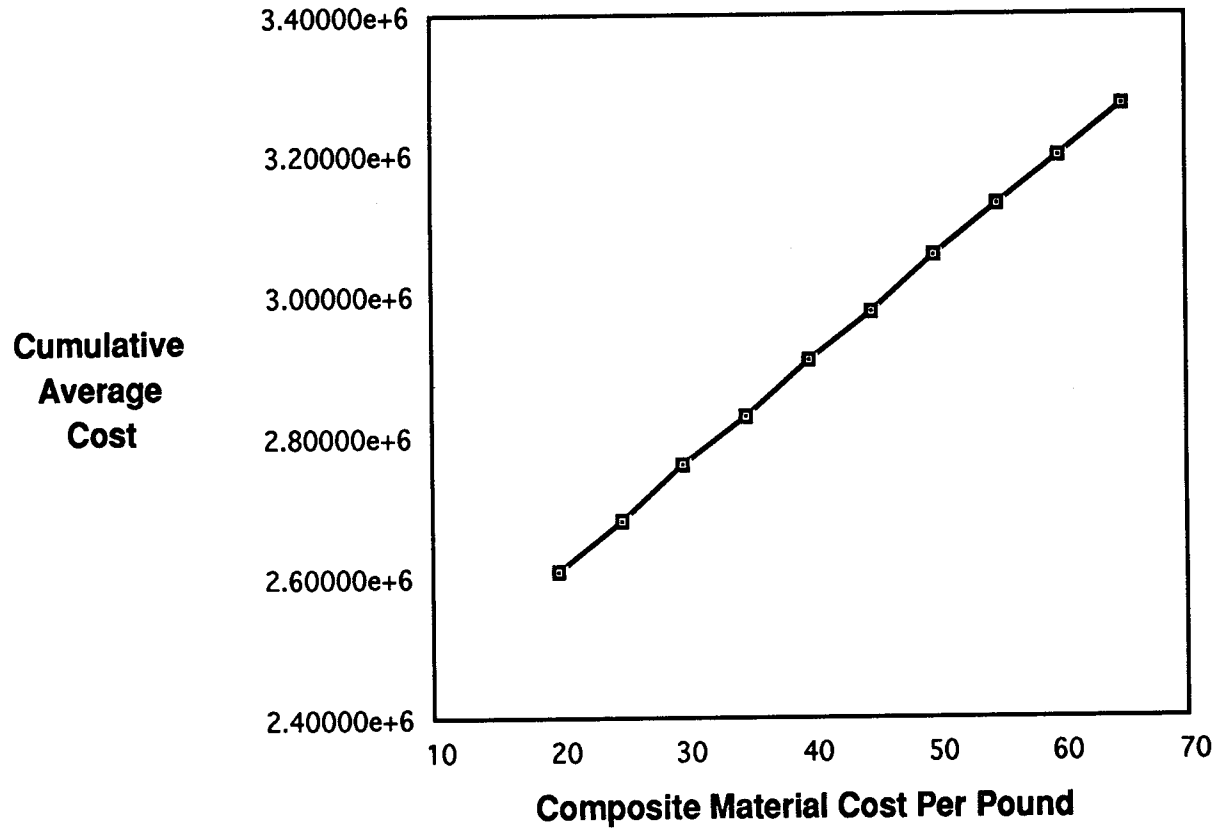

Figure 46. Resin Transfer Molded Design Concept Composite Material Cost Sensitivity Study

Table 16, Cost Analysis Report.

COST ANALYSIS REPORT SUMMARY

TITLE - FRONT SPAR
PREMISES

ACTSPAR - MODEL NASA DATE 6/21/90

DESIGN QUANTITY = 300 ACFT
LOT QUANTITY = 24 ACFT

THE SPAR DESIGNS COMPARE "I" BEAM STRUCTURE WITH "C" CHANNEL STRUCTURE EACH WITH BLADE STIFFENERS OR SANDWICH WEBS FOR STIFFNESS. A THIRD ALTERNATIVE IS EACH CONFIGURATION USING THERMOPLASTIC MATERIAL.

DESIGN ALTERNATIVES

	NO.1	NO.2	NO. 3	NO. 4	NO. 5	NO. 6
NON-RECURRING COSTS	0	0	0	0	0	0
RECURRING COSTS						
RAW MATERIAL	35777	35777	26479	26479	98859	98859
PURCHASED PARTS	0	0	0	0	0	0
MAJOR EQUIPMENT	0	0	0	0	0	0
LABOR- FAB & SUBASY	119004	79256	87870	58399	122136	81341
LABOR- ASSY & INSTL	0	0	7598	7598	0	0
QUALITY ASSURANCE	10399	6926	8342	5767	10673	7108
SUSTAINING CME	5879	3915	4716	3260	6033	4018
SUSTAINING ENG	4955	3659	3909	2947	6950	5619
OTHER DIRECT COSTS	0	0	0	0	0	0
SUB-TOTAL RECURRING	176015	129533	138914	104451	244651	196945
CUM AVERAGE COST	176015	129533	138914	104451	244651	196945
OTHER PROGRAM COSTS	0	0	0	0	0	0
CUM AVG PROGRAM COST	176015	129533	138914	104451	244651	196945

DESIGN ALTERNATIVES

1. "I" BEAM WITH BLADE STIFFENERS
2. "C" CHANNEL WITH BLADE STIFFENERS
3. "I" BEAM WITH SANDWICH MATERIAL
4. "C" BEAM WITH SANDWICH MATERIAL
5. "I" BEAM WITH TP BEADED STIFF
6. "C" BEAM WITH TP BEADED STIFF

BREAK-EVEN POINT

REF. ACFT
1001 ACFT *
NONE - ALWAYS LESS
NONE - ALWAYS LESS
NONE - ALWAYS LESS
47 ACFT *

* LESS COSTLY UP TO ACFT QUANTITY SHOWN, AFTER WHICH MORE COSTLY.

SUMMARY	TARGET ELEMENTS COST	LASC UNIT COST	TOTAL UNIT COST	TOTAL PROG COST	NET PROG SAVINGS	NON- RECURRING COST
DESIGN 1	176015	176015	176015	52804400	0	0
DESIGN 2	129533	129533	129533	38859856	13944544	0
DESIGN 3	138914	138914	138914	41674176	11130224	0
DESIGN 4	104451	104451	104551	31335248	21469152	0
DESIGN 5	244651	244651	244651	73395328	-20590928	0
DESIGN 6	196945	196945	196945	59083616	-6279216	0

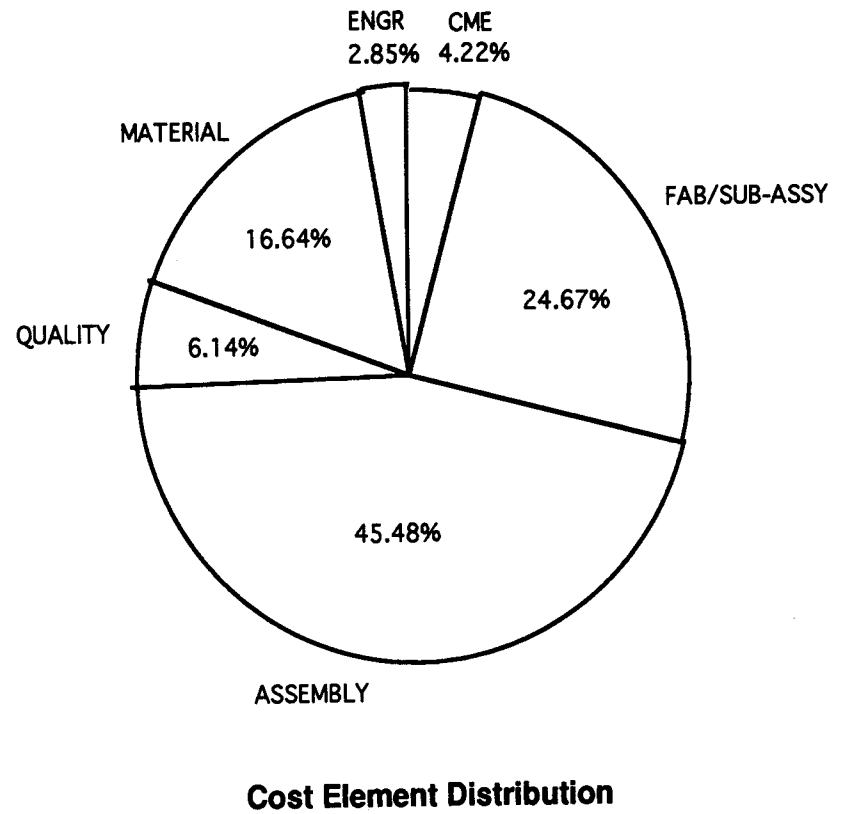
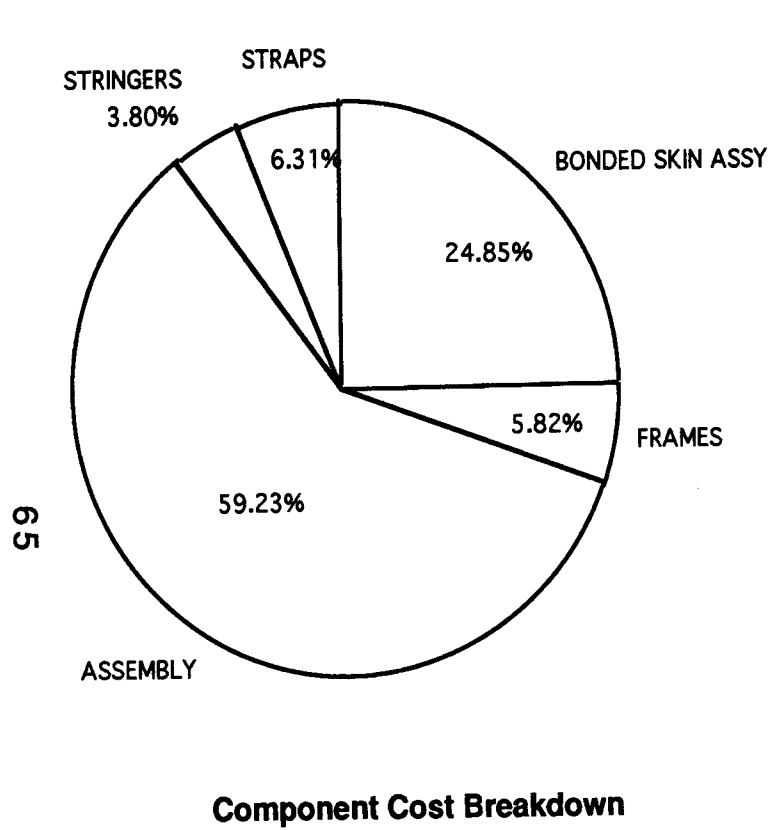
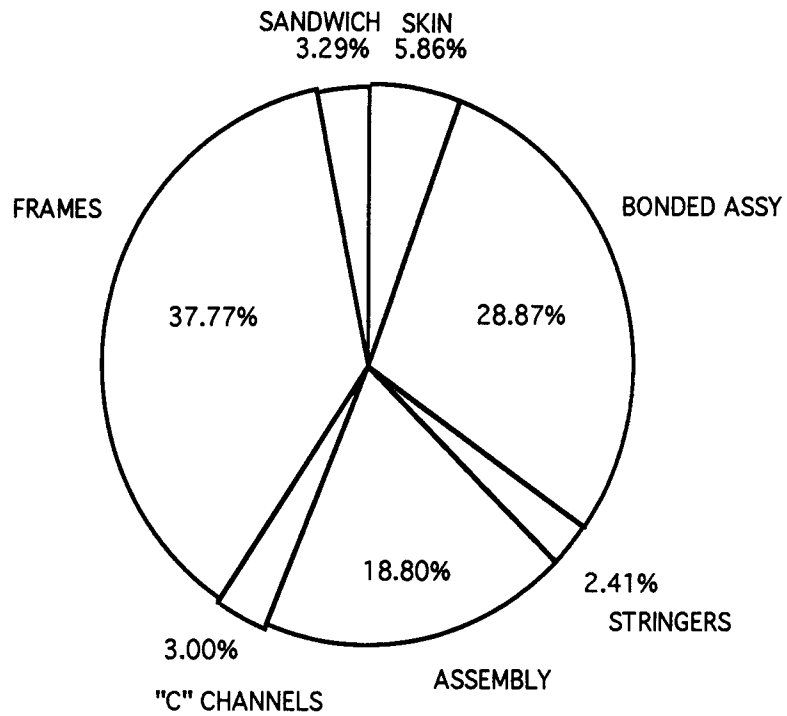
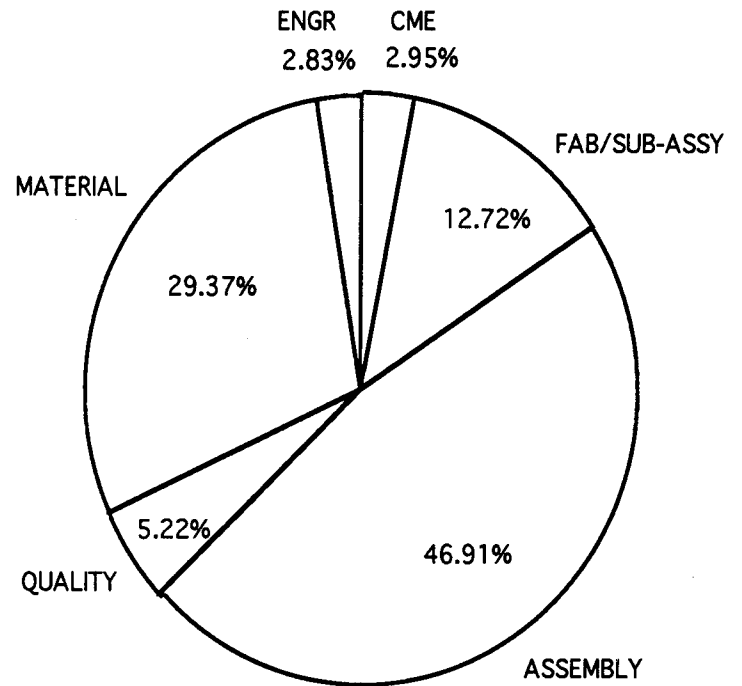

Figure 47. L-1011 Fuselage Segment
Baseline Cost Distribution

66



Component Cost Breakdown



Cost Element Distribution

Figure 48. Sandwich Fuselage Cost Distribution.

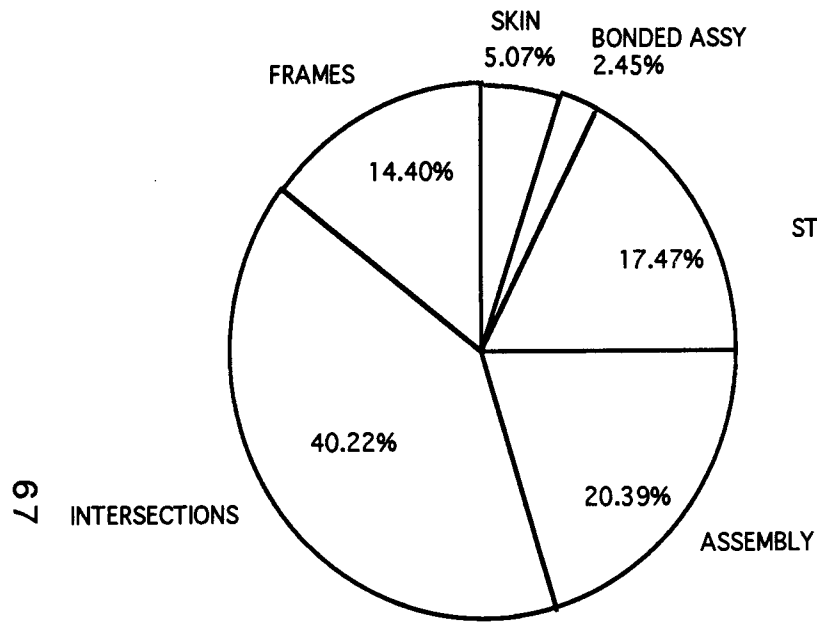

Component Cost Breakdown

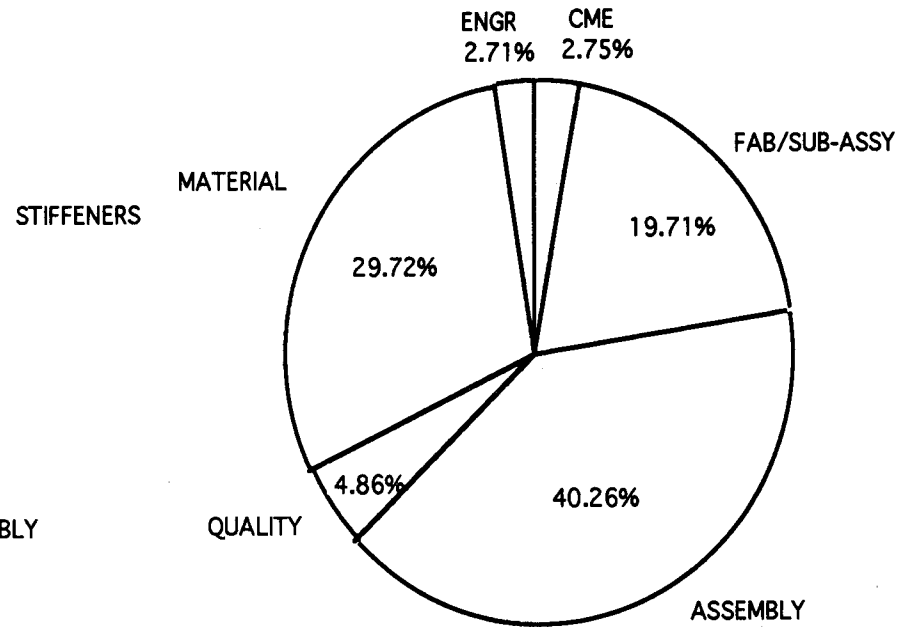

Cost Element Distribution

Figure 49. Geodesic Fuselage Cost Distribution.

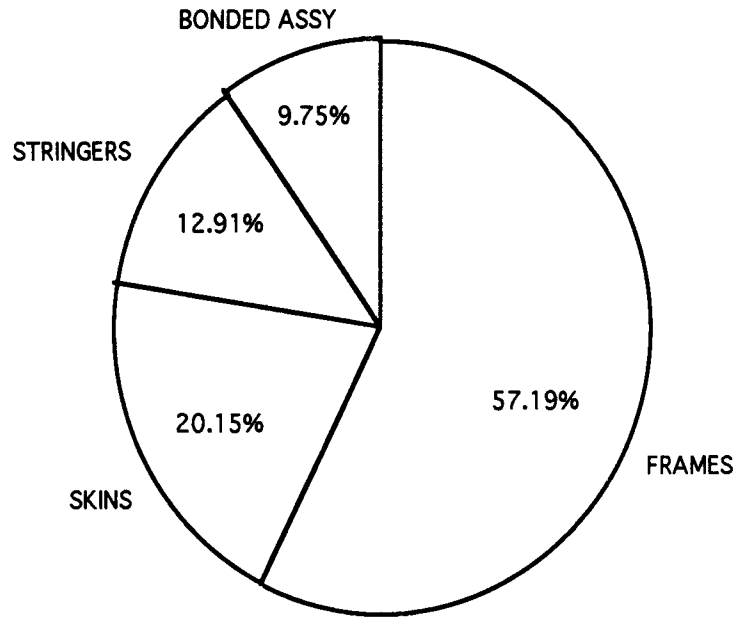

Component Cost Breakdown

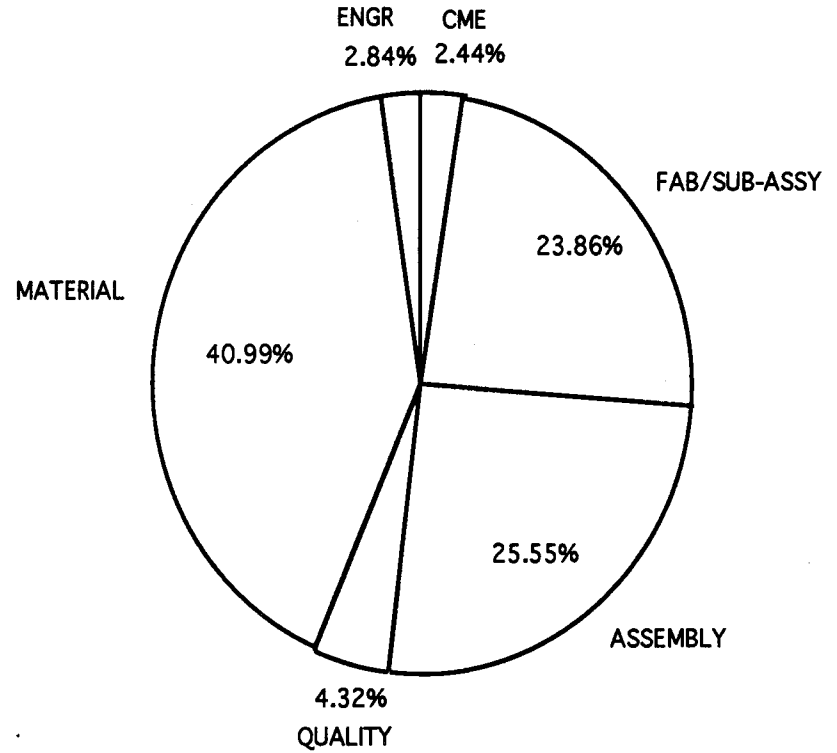

Cost Element Distribution

Figure 50. Stiffened Shell Cost Distribution.

2.5 Weights Trade Studies

Weights analysis were performed for the three wing concepts (Automatic Tow Placed, Resin Transfer Molded and Modular), the Braided wing had been previously dropped and the three fuselage concepts (Sandwich, Geodesic and Stiffened Shell) developed in the "Initial Assessment/Ranking" phase of task 1. The weights developed were based on the design packages received from the Design/Manufacturing Integration (D/M I) team. The composite weights were then compared to the Lockheed L-1011-1 baseline aircraft weights. Baseline weights were obtained from L-1011 files and reviewed to insure that a "component" to "component" comparison was obtained.

2.5.1 Weights Estimating Assumptions

During the weight estimating process the total weight for the wing box structure was developed. The weight was broken down to include the upper cover, lower cover, ribs, bulkheads, spar structure and body/main landing gear support structure. All weights reported are based on per aircraft estimates.

The weight was first estimated for outer wing station (OWS) 151.1 from the composite design drawings. Then a spanwise variation, see Figure 51, based on L-1011 data was applied to arrive at the total weight for each wing concept. Actual weights were determined for the upper/lower covers, ribs and spar webs, additional estimated weight was then added for the landing gear, engine mounts and access doors. The results of the wing weights analysis are shown in Table 17.

For the fuselage concepts the total weight was estimated for the fuselage shell between fuselage station (FS) 235 to FS 983 based on the composite design drawings developed by the D/M I team. The sizing on the drawings were developed for FS 750 and included the skins, stiffeners and frames. No circumferential variation was assumed or applied, an average section was analyzed. The results of the fuselage weights analysis are shown in Table 18.

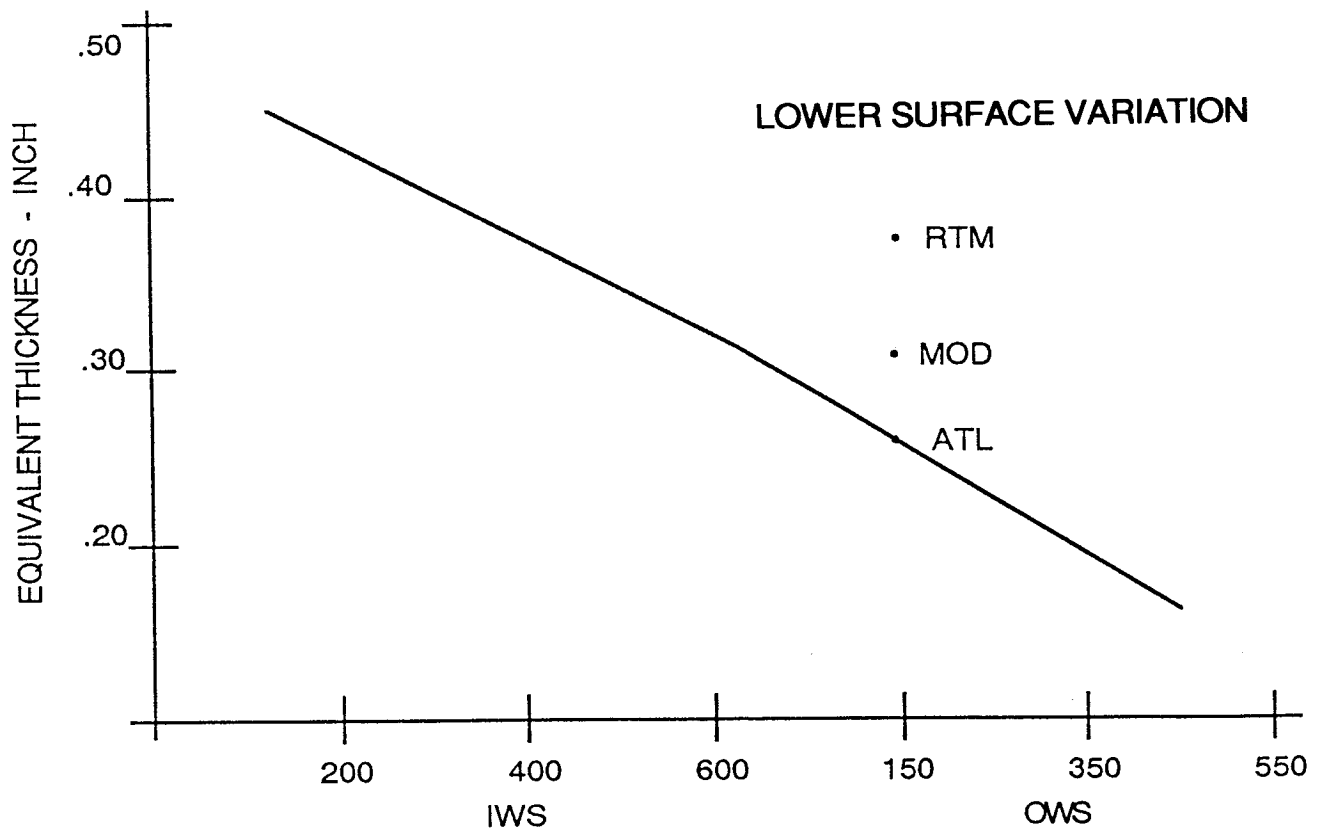
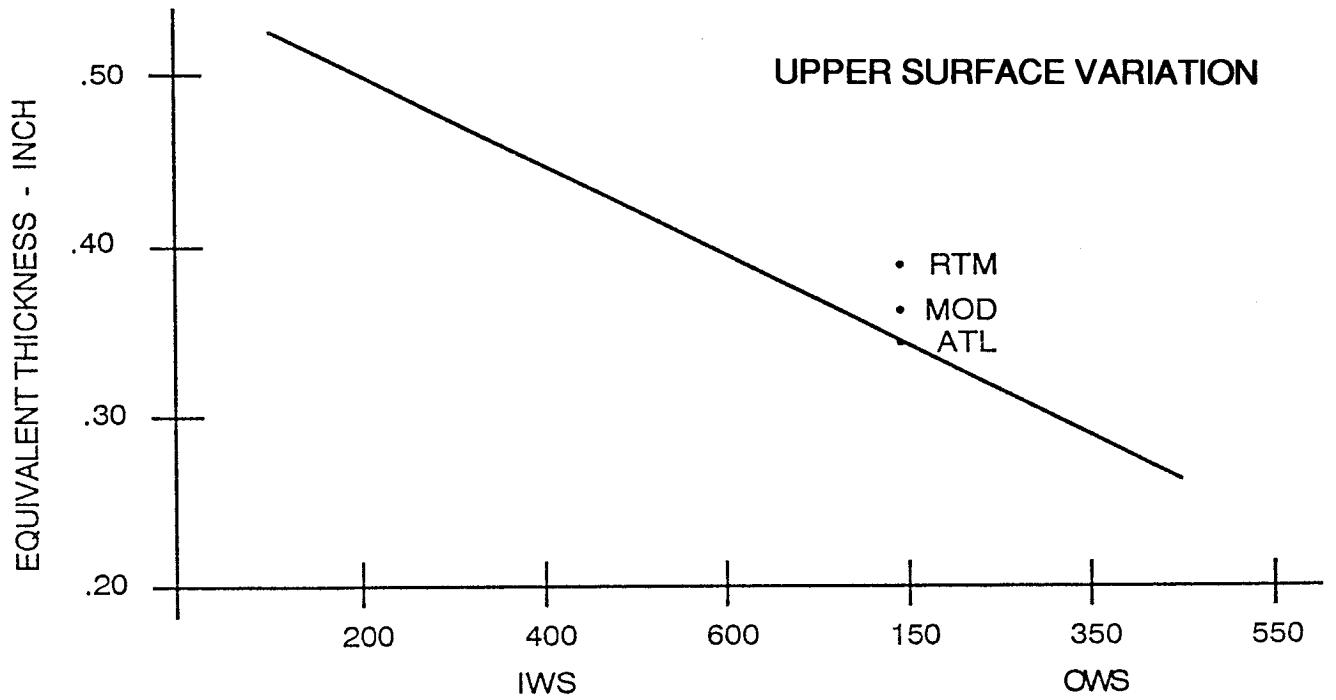

Figure 51, Wing Box Upper And Lower Surface Weight Variation.

Table 17, Summary Of Wing Box Weights.

	ADVANCED COMPOSITES		
	MODULAR	RTM	ATL
UPPER SURFACE	6518	6989	6316
LOWER SURFACE	7497	8869	6713
RIBS & BLKHDS	2565	2565	2565
SPAR WEBS & CAPS	1071 680	1257 693	1229 630
BODY JOINT, MLG SUPT.	1500	1500	1500
TOTAL (LBS)	19873	21873	18953

Table 18, Summary Of Fuselage Weights.

	COMPOSITE CONCEPT		
	SANDWICH	STIFFENED	GEODESIC
SKIN/STIFFENERS	6313	5568	6989
MINOR FRAMES	1054	1132	1186
TOTAL (LBS)	7367	6700	8175

2.5.2 Weight Drivers

Several items have been identified as weight drivers during the weights analysis based on past experience. Those items that were

identified are listed below:

- Discrete vs. Integral Stiffeners
- Number of Fasteners
- Material Form

As discussed above, all of the design wing and fuselage concepts strove to minimize costs and weights through the use of co-cured and/or co-bonded structures. By using this design philosophy the effects of the first two items listed above are diminished. Leading to the selection of integrally stiffened structures wherever possible

Some additional items are known to be potential weight drivers but were not investigated in detail in the "Initial/Assessment Ranking" part of task 1. These topics are;

- Joints
- Cut-outs
- Uniform vs. Tailored Thickness

and are further developed in the next part of task 1 "Structural Design Development".

2.5.3 Weights Comparison

Figure 52 shows the results of the composite design weights analysis and the aluminum L-1011 baseline weights. As can be seen the Automatic Tow Placed wing concept has the highest weight savings at 31.8%. The Modular wing concept is second with a 28.7% weight savings and finally the Resin Transfer Molded wing concept at a 21.3% weight savings. Figure 53 shows the results of the fuselage weights analysis and the baseline fuselage weights. The Stiffened Shell concept is the lightest with a 30.3% weight savings. The Sandwich concept is second at 23.3% weight savings and the Geodesic concept is last at 14.9% weight savings.

The program goals for weight savings were 40% for a re-sized aircraft. The approach taken was to adjust the weight goal to account for re-sizing of the aircraft, and to use the L-1011 baseline configuration as

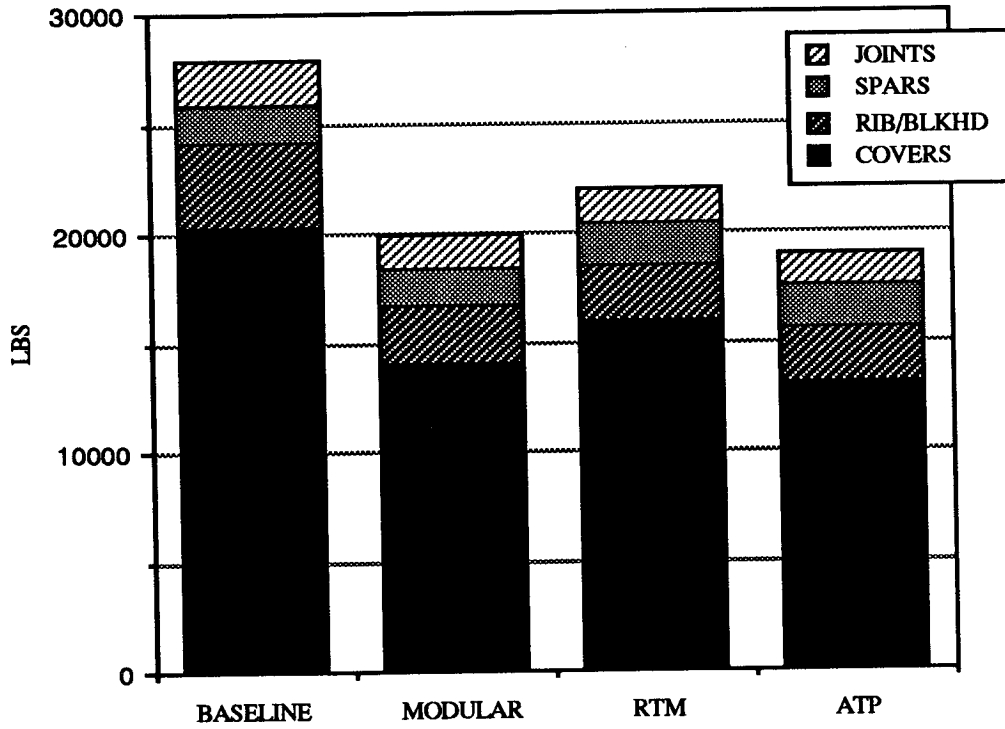

Figure 52, Wing Weights Comparison.

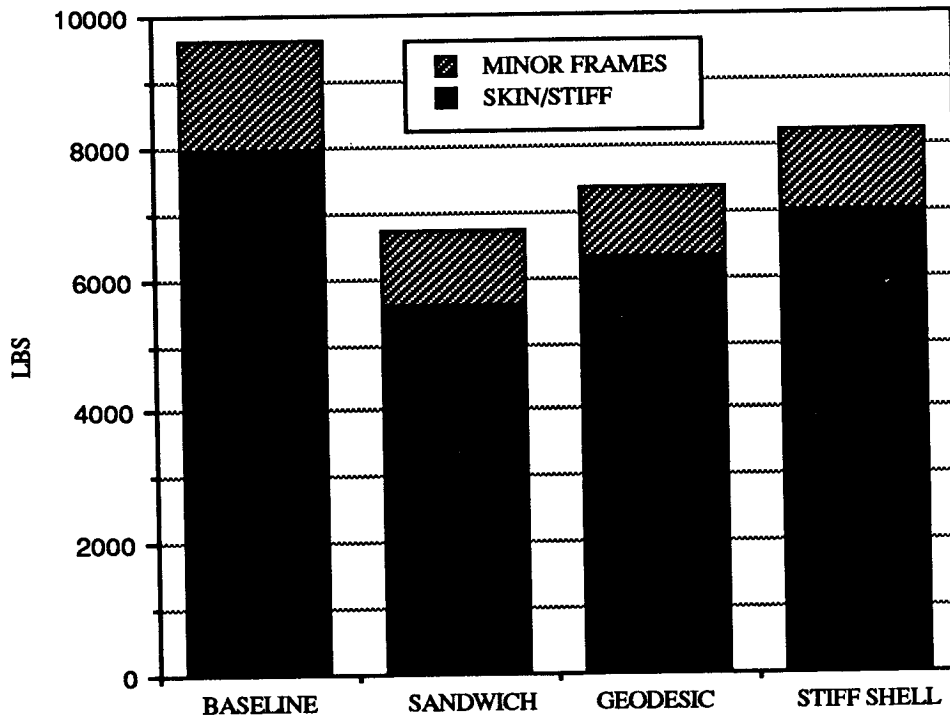

Figure 53, Fuselage Weights Comparison.

is (not re-sized). Therefore, the 40% goal was modified to 34% to account for re-sizing of the aircraft. The 6% reduction is a very conservative estimate of the gains possible with the re-sizing effect. Re-sizing the aircraft would reduce the amount of fuel required to meet the same flight/range requirements. Also, the fuel weight reduction allows the engine to be re-sized, this creates a "snow ball" effect which can lead to substantial reductions or increases in range, payload, etc.

2.6 Supportability Trade Studies

All wing and fuselage design concepts were developed with supportability issues in mind. The major emphasis was in developing a maintainable/repairable structural concept that could be supported in the field with standard repair procedures.

2.6.1 Rationale

Following completion of the design packages all of the concepts were evaluated for maintainability/repair, inspectability and durability/damage tolerance concerns. Experts in the respective fields evaluated the concepts and rated them accordingly from 1 to 10 with 10 being the highest. The results from these evaluations are shown in Tables 19 through 21.

2.7 Trade Study Results

After all cost, weights and "ilities" evaluations were completed, the down select process discussed below was used to determine which concepts to carry into the "Structural Concept Development" subtask of task 1. In the development subtask the concepts would be developed in further detail, focusing on detail design of joints, cutouts, etc... The original plan was to take the top two wing and fuselage concepts into the development part of task 1. However, following NASA redirection only the top wing and the top fuselage were carried into the development subtask.

Table 19, Maintainability Evaluation Rationale.

CONCEPT	MAINTAIN-ABILITY	RATIONALE
MODULAR WING	6	MODULAR CONSTRUCTION FACILITATES LESS COSTLY REPAIR TECHNOLOGY. HEAVY STRUCTURAL DAMAGE IS UNREPAIRABLE AT FIELD LEVEL.
RTM WING	6	LEAK PATHS ARE ELIMINATED. CONSTRUCTION FACILITATES LESS COSTLY REPAIR TECHNOLOGY. HEAVY STRUCTURAL DAMAGE IS UNREPAIRABLE AT FIELD LEVEL.
ATP WING	7	LEAK PATHS ARE ELIMINATED. REPAIR AT FIELD LEVEL IS LESS COSTLY. HEAVY DAMAGE WILL INDUCE REMOVE AND REPLACEMENT OF ENTIRE STRUCTURE.
SANDWICH FUSELAGE	8	COMPOSITE MATERIALS ELIMINATE MOST MAINTAINABILITY ISSUES. REPAIR CAN BE EASILY DONE AT THE FIELD LEVEL.
GEODESIC FUSELAGE	4	CREATES REPAIR PROBLEMS THAT CANNOT BE SATISFIED WITHOUT MAJOR RECONSTRUCTION OF LARGE AREAS. REQUIRES EXCESSIVE SPARE /REPAIR PARTS INVENTORY.
STIFFENED SHELL FUSELAGE	6	REPAIR PROBLEMS IN TRANSFERING LOAD ACROSS DAMAGED AREA.

Table 20, Inspectability Evaluation Rationale.

CONCEPT	INSPECT-ABILITY	RATIONALE
MODULAR WING	6	SEPARATE COMPONENTS CAN BE INSPECTED, BUT ALSO WILL REQUIRE EXTENSIVE POST PROCESS INSPECTION DUE TO COCONSOLIDATION AND/OR BONDING
RTM WING	8	PREFORM MAY BE INSPECTED BEFORE MOLD FILLING. WIDE RANGE OF IN-PROCESSMETHODS COULD BE USED FOR MONITORING THE MOLD FILL AND CURE, INCLUDING PROCESS MODELS.
ATP WING	6	TOW QUALITY, SIZE AND PLACEMENT MUST BE MONITORED AT ALL TIMES, WILL DEPEND ON MACHINE. PLACEMENT MONITORING NEEDS TO BE DEVELOPED.
SANDWICH FUSELAGE	5	TUBES COULD BE INSPECTED IN-LINE, BUT POST PROCESS WILL BE VERY DIFFICULT BETWEEN TUBES.
GEODESIC FUSELAGE	2	VERY COMPLEX GEOMETRY. THE TRUSS INTERSECTIONS ARE UNINSPECTABLE.
STIFFENED SHELL FUSELAGE	8	HIGH SCORE BECAUSE COMPONENTS MAY BE INSPECTED BEFORE FINAL CURE. IN-PROCESS INSPECTION OF PULTRUDED HATS AND RTM FRAMES HAVE EASY GOEMTRY.

Table 21, Durability Evaluation Rationale.

CONCEPT	DURABILITY / DAMAGE TOLERANCE	RATIONALE
MODULAR WING	3	CONCERN IS THAT IMPACT DAMAGE WILL CAUSE STIFFENER TO PULL AWAY FROM SKIN DRASTICALLY REDUCING MECHANICAL PROPERTIES.
RTM WING	7	THROUGH THE THICKNESS REINFORCEMENT SHOULD PREVENT STIFFENER UNBOND AND MINIMIZE IMPACT DAMAGE. LOWER FIBER VOLUME IS STILL A CONCERN, AS IT WOULD REDUCE STRUCTURAL INTEGRITY.
ATP WING	5	THIS IS TYPICAL OF CURRENT STRUCTURES.
SANDWICH FUSELAGE	3	THINNESS OF FACINGS IS A DURABILITY CONCERN. IMPACT COULD CAUSE SEPERATION OF TRIANGULAR TUBES OVER A LARGE REGION. THIS COULD REDUCE RESIDUAL PROPERTIES.
GEODESIC FUSELAGE	9	THIS CONFIGURATION IS HIGHLY REDUNDANT AND SHOULD HAVE OUT-STANDING DURABILITY AND DAMAGE TOLERANCE. HOWEVER, THERE IS A HIGH RISK OF CRITICAL MANUFACTURING FLAWS IN THE DIAGONAL CROSS-OVERS.
STIFFENED SHELL FUSELAGE	6	CONSIDERED SLIGHTLY BETTER THAN CURRENT STRUCTURES BECAUSE OF THE ELIMINATION OF FASTENERS AND HOLES.

The program goals of 40% weight savings, 25% cost savings and 50% part count reduction were assigned a weighting factor of 30%, 40% and 30%, respectively. Cost had previously been selected as the main program goal and was therefore weighted the highest, with weights and "Ilities" being weighted equally. The down select scores for cost and weights were developed by comparing the actual weight or cost to the target weight or cost through the following formula,

$$\text{Score} = (W_g / W_d) \times W_f$$

where; W_g = Weight or Cost Goal
 W_d = Weight or Cost of Design
 W_f = Weighting Factor (30 for Weights and 40 for Cost)

It was possible for the concepts to earn "bonus points" by surpassing the target goals. For example, if the weight goal was 20,000 lbs and a concepts estimated weight was 18,000 lbs that concept would score 33.3 points (20000/18000x30), exceeding the the weighting factor.

The "Ilities" evaluation was conducted by having experts in the various disciplines score the concepts from one to ten (10 being the best), taking the average and multiplying by the weighting factor (.3 for "Ilities"). The disciplines involved were; Design, Manufacturing and Producibility. These evaluations were combined with those developed in Section 1.6 (Inspectability, Maintainability/Repair and Damage Tolerance/Durability) to form a complete overall evaluation of the concepts. Table 22 shows the results of the "Ilities" trade study results. These scores were added to the cost and weights scores to arrive at the total scores for each concept.

2.7.1 Wing Results

Table 23 shows the final results of the down select ranking of the wing concepts. The Automatic Tow Placed wing is the clear winner with a score of 85.65 well above the Modular wing concept ranking second with a score of 73.77 and finally the RTM wing with a score of 71.95. Therefore, the ATP wing concept was carried into the development subtask of task 1. The ATP wing concept scored very well in both the cost and weights areas by nearly matching the target goals. All three concepts were scored fairly closely in the weights area. It is interesting to note that the RTM concept scored well in the "Ilities" area while being penalized in the cost area. This was due to difficulties in loading the preform into the tool and high tool costs. In summary, some of the details of the ATP wing concept are shown in Figure 54 below. The concept had integral co-cured blade stiffeners and spar caps, co-cured rib caps and mechanically attached rib webs.

Table 23, Wing Trade Study Results & Final Ranking.

CONCEPT		WEIGHT	COST	ILITIES	TOTAL	RANK
WING	MODULAR	26.91	34.36	12.5	73.77	2
	RTM	24.29	27.16	20.5	71.95	3
	ATP	28.16	39.49	18.0	85.65	1

CONCEPT	TECHNOLOGY ADVANCEMENT		PRODUCIBILITY	DAMAGE TOL/ DURABILITY	INSPECTABILITY	MAINTAINABILITY/ REPAIR	TOTAL	SCORE
	DESIGN	MFG						
MODULAR WING	4	3	3	3	6	6	25	12.5
RTM WING	5	9	6	7	8	6	41	20.5
ATP WING	5	7	6	5	6	7	36	18.0
SANDWICH FUSELAGE	8	7	3	3	5	8	34	17.0
GEODESIC FUSELAGE	6	7	3	9	2	4	31	15.5
STIFFENED SHELL FUSELAGE	4	3	8	6	8	6	35	17.5

Table 22, "Ilities" Trade Study Results.

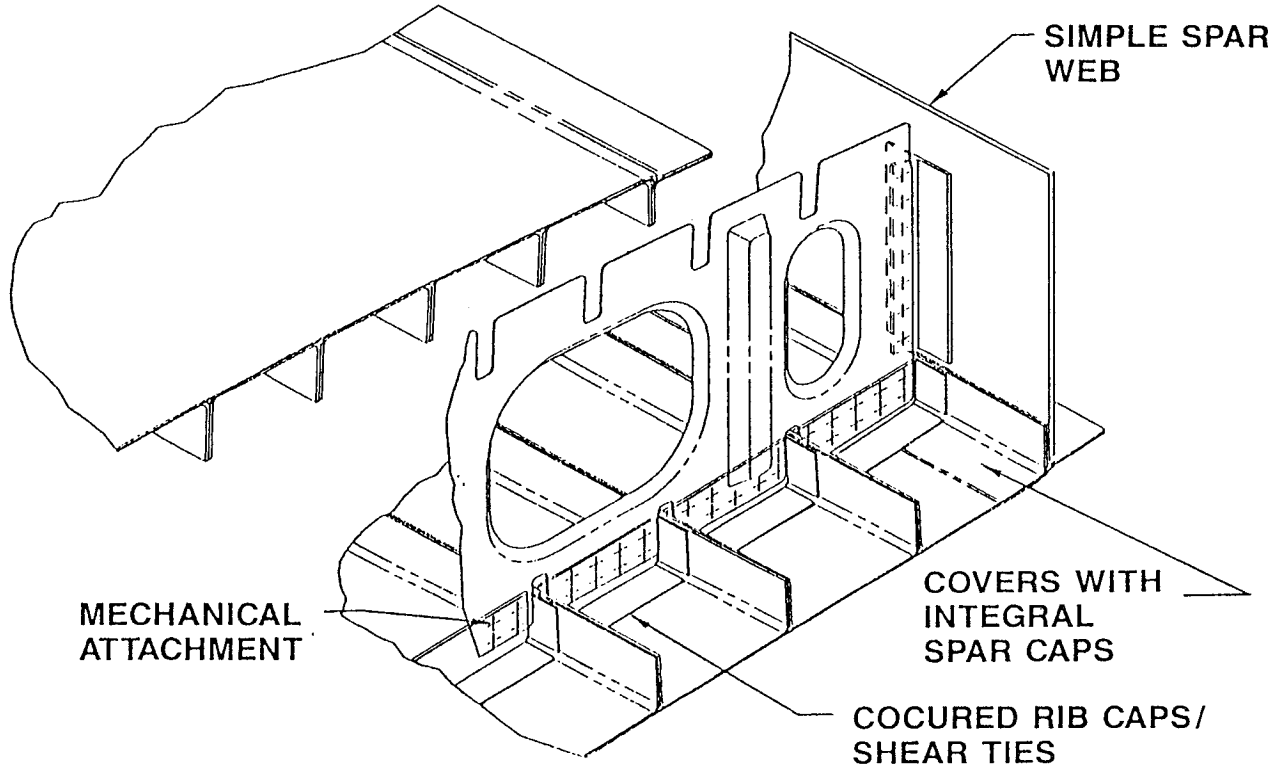

Figure 54, ATP Wing Concept Details.

2.7.2 Fuselage Results

The results of the fuselage down select ranking shown in Table 24 indicate that the Stiffened Shell concept (87.99 points) is the winner by a substantial margin, over 20 points. In second place is the Sandwich fuselage concept (63.90 points) and finally the Geodesic concept (48.88 points). Therefore, the Stiffened Shell concept was carried into the development subtask of task 1. The large spread in scores can be attributed to the substantial difference in design configurations. The Stiffened Shell concept was awarded "bonus" points for exceeding the cost target goal. While the Geodesic was penalized heavily on cost for having too many parts, addition of all the stiffener covers greatly increased the manufacturing/assembly costs. The Sandwich concept scored best in the weights area which was to be expected, sandwich construction is generally very weight efficient. Figure 55 shows some of

the details of the Stiffened Shell concept, which consisted of a simple design with co-cured hat stiffeners and "J" section circumferential frames.

Table 24, Fuselage Trade Study Results & Final Ranking.

	CONCEPT	WEIGHT	COST	ILITIES	TOTAL	RANK
FUSELAGE	SANDWICH	25.05	21.85	17.0	63.90	2
	GEODESIC	22.57	10.81	15.5	48.88	3
	STIFFENED SHELL	27.54	42.95	17.5	87.99	1

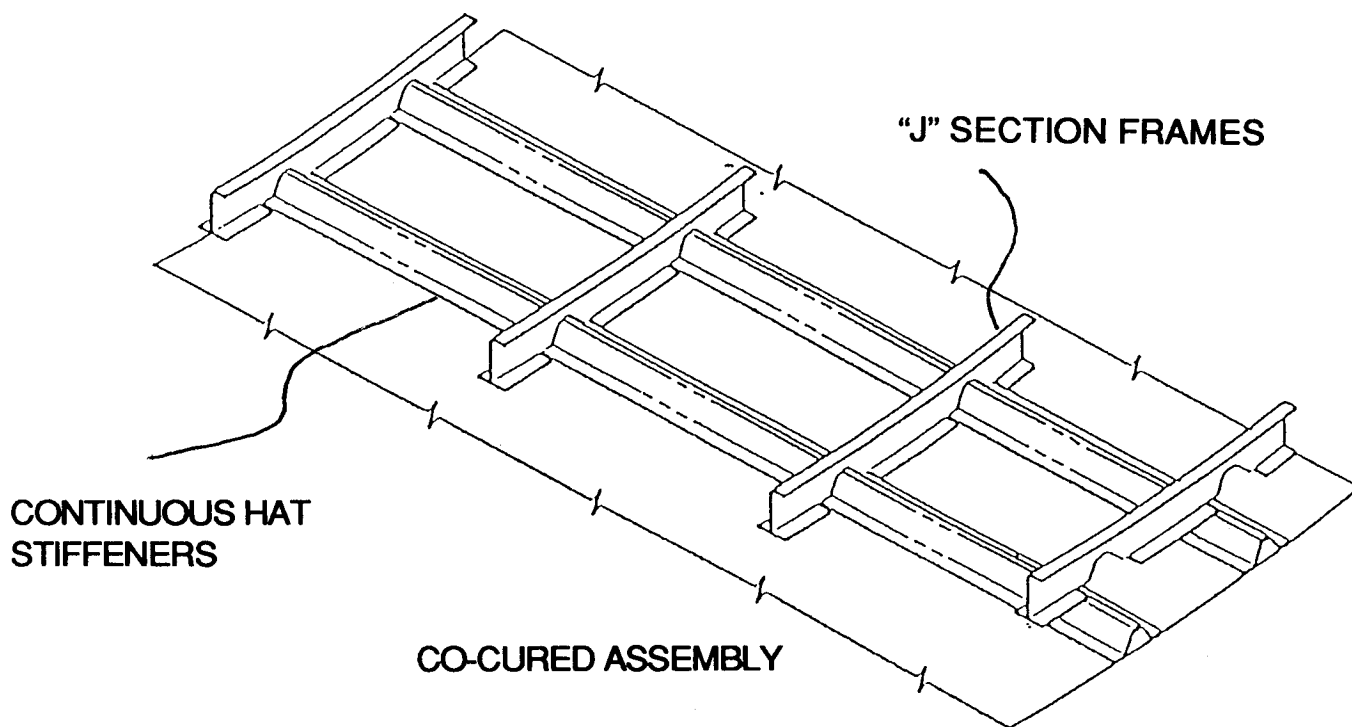

Figure 55, Stiffened Shell Fuselage Concept.

3.0 Structural Design Concept

At the completion of the design trade studies the results were presented to NASA personnel at a formal review. Since one wing and fuselage concept emerged as clear winners it was agreed that the remainder of Task 1 would concentrate on these two concepts and no backups would be carried into the next subtask.

Boeing and Douglas had performed similar trade studies . Following full review of all three contracts NASA determined that Boeing and Lockheed had reached very similar conclusions.

The NASA ACT Steering Committee discussed the results of the three program trade studies in the fall of 1990 and recommended that future work be focused in three areas: resin transfer molding, automated fiber placement and textile structures. By mutual agreement Lockheed was selected to concentrate on textile structures and to restructure Phase II of the program to this end.

The remaining Task 1 effort was terminated. This section discusses the efforts in subtask 2 prior to the termination.

Following the August 1, 1990 program review, NASA directed that the back-up concepts be eliminated from further consideration because the winners were ahead by a considerable margin and showed potential for meeting the programs goals. Therefore, only the Automatic Tow Placed Wing and the Stiffened Shell Fuselage were carried into the detail design subtask. The Modular Wing and the Sandwich Fuselage concepts were dropped from further consideration.

In the "Initial Assessment/Ranking" subtask, the wing and fuselage concepts were developed in enough detail to generate cost and weight data. For the second subtask - "Structural Concept Development", the winning concepts were to be defined in greater detail paying particular attention to such details as; cutouts, joints, taper effects, etc.

In the Structural Design Development subtask, new manufacturing

processes were to be evaluated in an attempt to further reduce costs. For the wing, two manufacturing processes were to be evaluated and compared. One of the panel concepts was the original fully automatic tow placed panel. The other panel concept was a braided/automatic tow placed concept, with the U-channel blade stiffeners braided and the skin automatic tow placed. This allowed for a cost as well as structural comparison and a final selection of the best process for this application.

Material

The material system proposed for the ATP Wing and Stiffened Shell Fuselage concepts is a hybrid of Hercules AS4 - IM7 graphite fiber and Hercules 8552 toughened epoxy. This combination is believed to provide the best balance of mechanical properties, processibility and cost. The AS4/IM7 hybrid allows the tailoring of mechanical properties. For example, in the wing covers high modulus (high cost) IM7 fiber will be used in the stiffeners and high strength (low cost) AS4 fiber for the skin areas. The 8552 toughened epoxy is a 350°F cure, 180°F service system that is available in all material forms required for this task. This hybrid system is estimated, by Hercules, to cost \$40/lb for a 66% AS4 - 34% IM7/8552 mix in the large production volume range. This estimated material cost is consistent with the cost data generated in the "Initial Assessment Ranking" subtask.

3.1 Wing Structures

3.1.1 Joints

Planned work on joints in wing structures had not begun at the time of program redirection.

3.1.2 Cutouts

All cutouts required for access doors, fuel probes, etc., were laid out for the upper and lower wing covers. Different skin/stiffener tapering configurations were developed for discussion with Hercules in order to get a better understanding of the capabilities of their tow placement

machine.

Five design approaches, see Figures 56 through 60, for handling cutouts were developed and presented to the D/M I team for review. The first two concepts used metallic inserts for local reinforcement while the final three concepts were all composite designs. Concept #1 attempted to redistribute the cutout loads through metallic (Ti) inserts in the U-channel sections. Concept #2 was similar to concept #1 except that the loads were redistributed through a metallic doubler in the outer skin of the panel. Concept #3 fully utilized the ATP process by placing some of the material around the cutout area. Concept #4 placed the Gr/Ep doubler material in the U-channel sections and had a constant section outer skin, and, finally, Concept 5 placed some of the Gr/Ep doubler material in both the U-channel section and the outer skin.

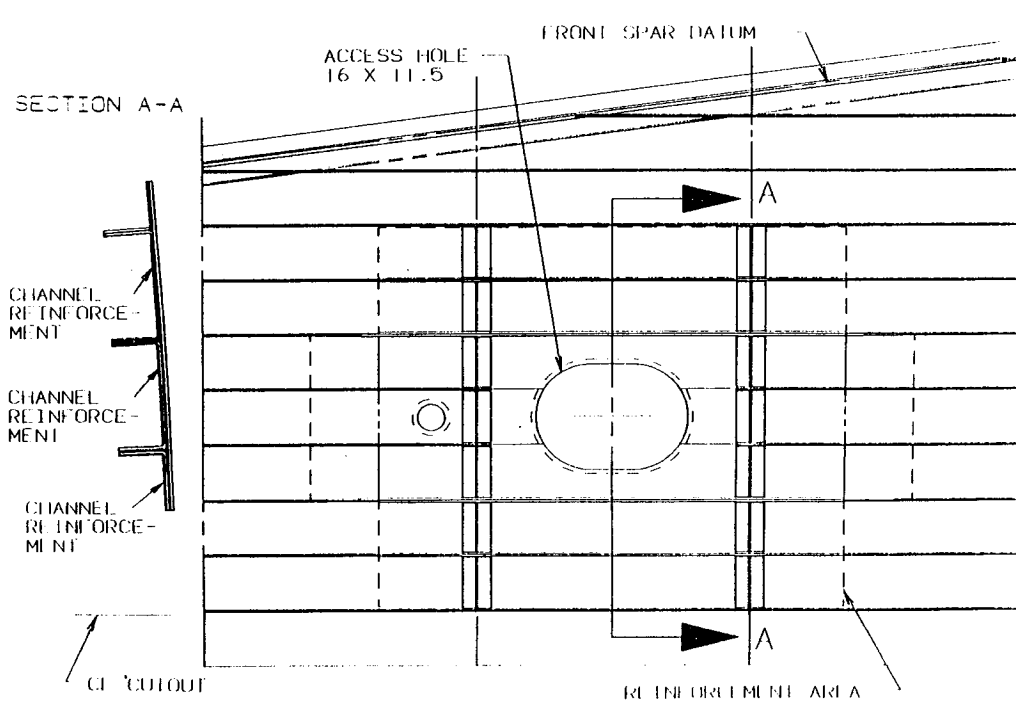

Figure 56, Cutout Concept No. 1.

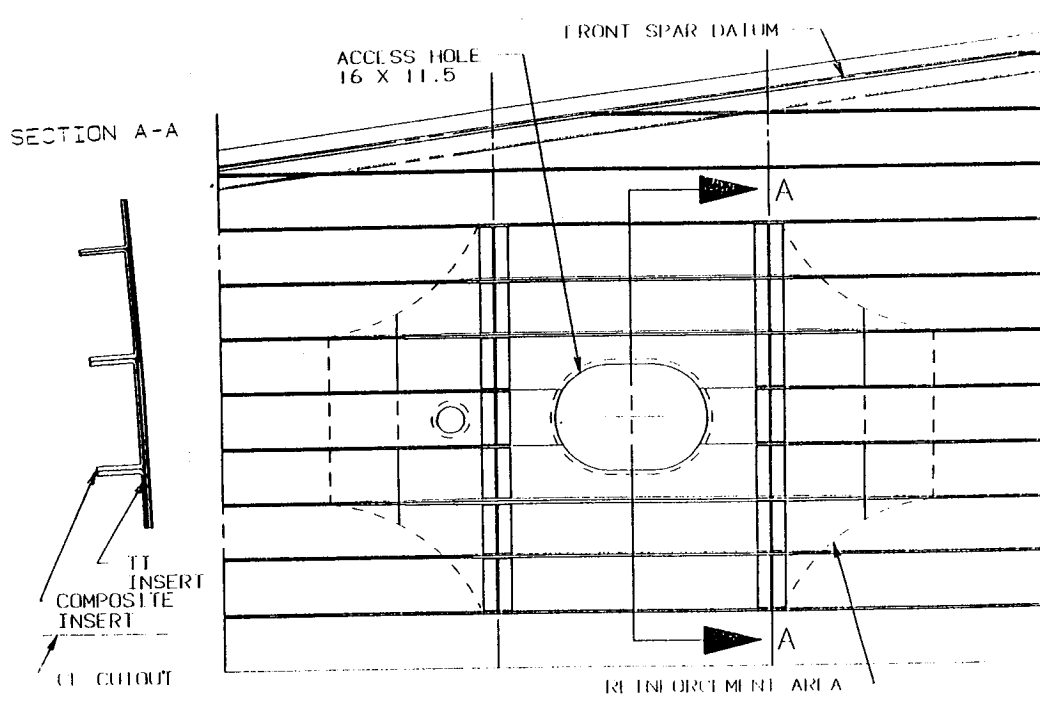

Figure 57, Cutout Concept #2.

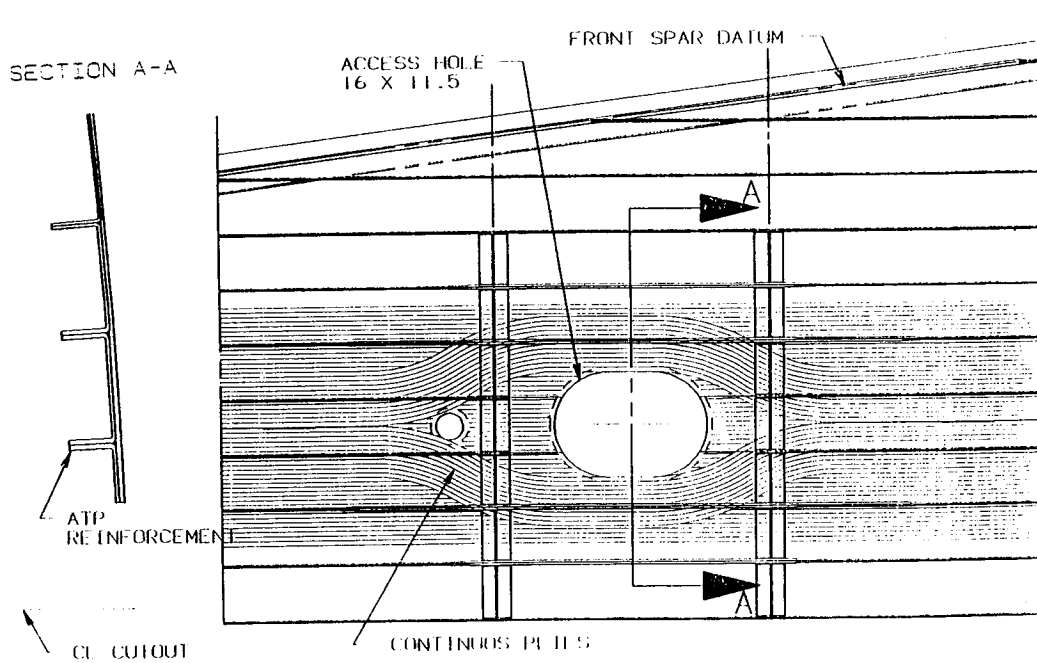

Figure 58, Cutout Concept #3.

~~2~~

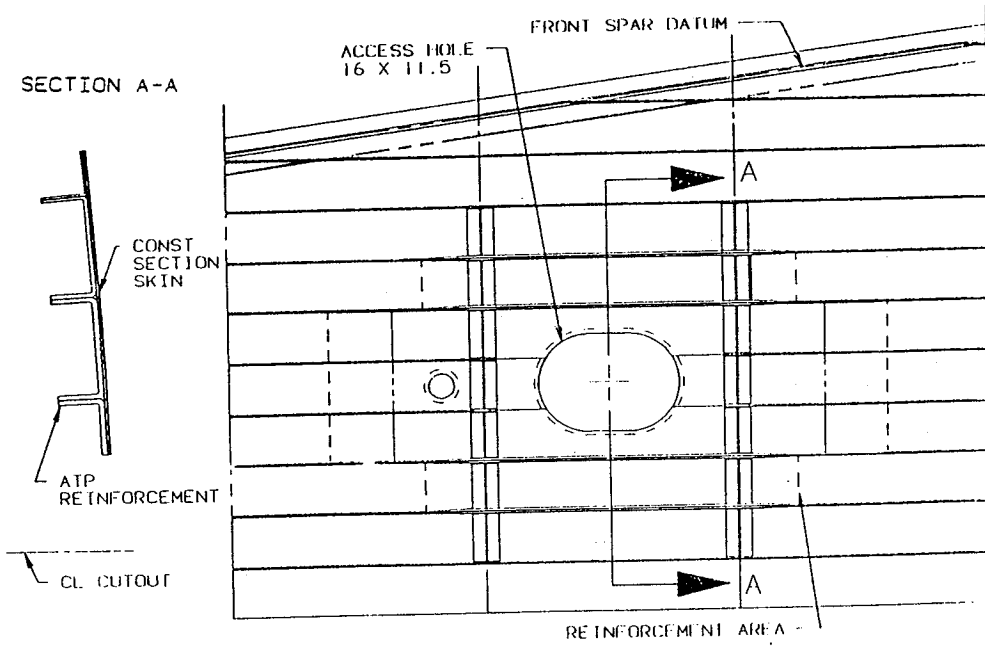

Figure 59, Cutout Concept #4.

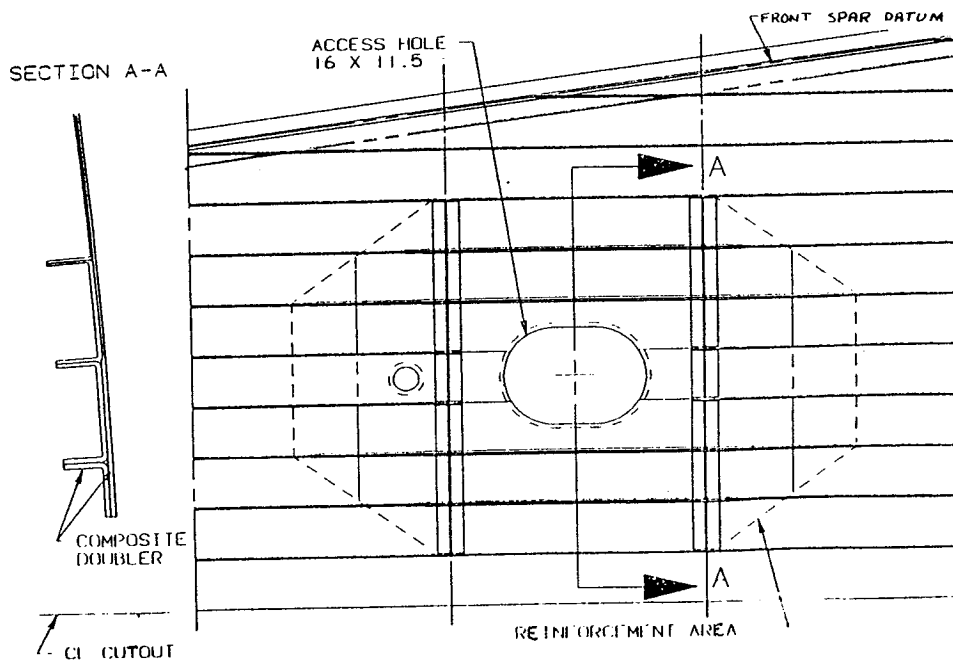

Figure 60, Cutout Concept # 5.

Table 25 shows some of the pros and cons identified for each concept. Following the review by the D/M I team, the more promising concepts were to be further developed and examined to determine their impact on cost and weights. Of the five cutout concepts under consideration, two were eliminated from further consideration. Concepts # 1 and # 2 (with metal inserts) were dropped because they were thought to be less effective and created several manufacturing/inspection problems. Also Concept #3 (curved plies/heavy channels) and Concept #5 (heavy skin/channel) were combined as they are similar concepts. Concept #5 would be the back-up if the curved plies concept were not feasible. Therefore, the remaining concepts (all composite designs) were: Concept #3 with the local reinforcement in both the outer skin (with the curved plies) and the U-channels; and Concept #4 with the heavy U-channels and constant section outer skin. These two concepts were to be further developed and analyzed for cost and weights impact, however, all activity on task 1 was terminated.

2.1.3 Taper Effects

For the ATP wing, a more detailed layout of the L-1011 baseline wing was started to investigate the weight impact of changing the blade stiffener spacing to better match-up with the rib spacing. This was an attempt to reduce costs by simplifying the stiffener termination at the front spar. After investigating several different spacing and taper schemes for the wing stiffeners, it was determined that this option was not practical. This is mainly due to the high spanwise taper ratio of the wing causing many stiffeners to terminate along the span. Terminating the stiffeners causes manufacturing difficulties as well as creating a poor design by causing relatively large jumps in panel sizes. Therefore, this option was eliminated from further consideration.



2.1.4 Test Plan-Wing Structures

The Test Plan is shown in Table 26. The test plan made use of the building block approach to allow for the refinement of the designs and the manufacturing approaches used. All critical features of both the wing and fuselage concepts were to be examined. Wing Element Tests were to evaluate different manufacturing approaches and material forms. The

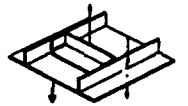

Table 25, Comparison of Cutout Concepts.

CONCEPT NO.	PROS	CONS
<p>1. METAL/ U- CHANNEL</p>	<ul style="list-style-type: none"> • U-CHANNELS DO NOT JOGGLE UP & DOWN • REDUCED OVERALL THICKNESS • REDUCED LAY-UP TIME 	<ul style="list-style-type: none"> • DIFFICULT TO OBTAIN PROPER COMPACTION OF COMPOSITE MATL • CTE MISMATCH • QUESTIONABLE BOND BETWEEN METAL AND COMPOSITE • DIFFICULT TO INSPECT • THICKNESS MISMATCH ON STRINGERS ALONG SPAN
<p>2. METAL/ SKIN</p>	<ul style="list-style-type: none"> • MACHINED LAMINATED DOUBLER VERY GRADUAL PAD-UPS • BALANCED STRINGER BUILD-UPS (COMPOSITE) • ELIMINATES COMPACTION PROBLEM 	<ul style="list-style-type: none"> • CTE MISMATCH • QUESTIONABLE BOND BETWEEN METAL AND COMPOSITE • DIFFICULT TO INSPECT • THICKNESS MISMATCH ON STRINGERS ALONG SPAN
<p>3. CURVED PLYS/ HEAVY CHL's</p>	<ul style="list-style-type: none"> • MINIMIZES LOAD PATH INTERRUPTIONS • FULLY AUTOMATED FABRICATION • GRADUAL STRINGER TAPERS • LOADS SHARED MORE EVENLY 	<ul style="list-style-type: none"> • REQUIRES MORE ADVANCED ANALYSIS (FEA)
<p>4. HEAVY CHANNEL</p>	<ul style="list-style-type: none"> • NO CHANNEL/STRINGER JOGGLES REQUIRED • AUTOMATED FABRICATION • EASY TO TAPER STRINGERS • CONSTANT SECTION OUTER SKIN 	<ul style="list-style-type: none"> • INCREASED ECCENTRICITY • POOR LOAD TRANSFER
<p>5. HEAVY SKIN/ CHANNELS</p>	<ul style="list-style-type: none"> • AUTOMATED FABRICATION • GRADUAL STRINGER TAPERS • REDUCED ECCENTRICITY 	<ul style="list-style-type: none"> • REQUIRES STRINGER/CHANNEL TO JOGGLE

Table 26, Task 1 Wing Structure Test Matrix.

Test	Test Configuration	Specimen Configurations (Replicates)	Total Number Of Tests Planned	Conditions	Instrumentation
Cover/Blade Pull-Off		2 (3)	6	RTD	None
Rib Cap/Cover Pull Off		2 (3)	6	RTD	None
Cover/Blade Compression		2 (3)	6	RTD	6 Axial Gages

Wing Element Tests

Test	Test Configuration	Specimen Configurations (Replicates)	Total Number Of Tests Planned	Conditions	Instrumentation
Spar Cap Element		2 (9)	6	Load Normal To Spar	None
			6	Load Parallel To Spar	
			6	Shear	
3 Stringer Compression		2 (2)	2 2	Notched With Impact Damage	8 Axial Gages

Wing Subcomponent Tests

cover/blade pull-off test was to validate the structural integrity of the interface between the blade and the skin. In this test different material forms such as braiding instead of automatic tow placement would have been evaluated. The rib cap/cover pull-off test was designed to validate the design and manufacturing concepts for the integral rib caps. Again, different material forms and cap configurations would be evaluated. The final wing element test was the cover/blade compression test which was

to further validate the upper/lower cover design and manufacturing concepts.

Following the element tests two wing cover configurations were to be evaluated during the Wing Subcomponent Testing. The subcomponents to be tested were the spar cap and a three stiffener compression panel. The spar cap test was to validate the integral spar cap configuration and its joint to the spar web. The three-stiffener panel test was intended to validate the design and compare the damage tolerance of the selected concepts.

The selected wing concept relied heavily on the availability of a totally automated lay-up method with the capability of planform and thickness tapering. Hercules and Cincinnati Milacron are two companies with this unique manufacturing capability and as such were considered as potential subcontractors for the manufacture of test components. Lockheed personnel visited Hercules Aerospace Co. in Magna, Utah to witness first hand their automated fiber placement machine in operation and to discuss the design/manufacturing approach for test panel fabrication. The demonstration of the machines capabilities showed the equipment was capable of producing the structural requirements.

3.2 Fuselage Structures

Structural concept development of the Stiffened Shell Fuselage concept concentrated on designing a fuselage section with a door. Although no plans existed to build a door section, the effect of a door on adjacent sections was pertinent. Topics of concern were areas such as the skin splice locations and the stringer transition from one barrel section to another.

Major emphasis during the structural concept development of the Stiffened Shell Fuselage configuration was placed on: (1) establishing suitable splice locations for the fuselage panel assemblies, (2) developing a design philosophy for the window belt structure and (3) evaluating alternate design concepts for circumferential and longitudinal splices.

The major cost driver in aircraft structures has been shown to be

assembly costs. In order to minimize assembly costs, large co-cured panels were proposed for the Stiffened Shell Fuselage. These large panels were to be spliced longitudinally at locations that were deemed to be convenient for assembly. Ideally, the lower fuselage section, consisting of the skin and floor beams, would go together first. The upper skin panels would then be installed to complete the barrel section. Figure 61 shows examples of splice concepts.

One recurring concern expressed by the D/M I team was been the mandrel requirements for the hat stiffeners. Therefore, Manufacturing was assigned the task of finalizing those requirements. They were to determine the specific capabilities available of current and emerging technology and provide inputs as to which direction the Stiffened Shell concept should take. The mandrel capabilities will influence the design by either requiring a fully cured hat stiffener to be bonded on at the final cure cycle, or allowing the use of a B-staged hat stiffener and co-curing the final assembly. Another task assigned to the D/M I team was to finalize the inspection requirements to the hat stiffeners. This task is also influenced by the selection of a mandrel/hat stiffener configuration.

The L-1011 baseline does not rely upon stringers between the door cutouts for the lateral bending loads. It uses a thicker skin in this area. A study was initiated to compare this design philosophy versus using continuous stringers along with a thinner skin above and below the windows and between the door cutouts. Also to be evaluated was the need for a circumferential fail safe straps as used on the L-1011.

As several tooling methods for the hat section stringers were evaluated, how they would apply to double contoured sections and not just a constant section was considered. It appeared that a pultrusion worked well for a constant section because the outside surface is a tool surface; this gave a better fit to adjacent parts. However, a different approach is required for the double contour section. Figure 62 shows the stringer penetrating a frame, a pre-molded clip bonds them together. The design of the stringer termination was not to be decided upon until a tooling concept was developed.

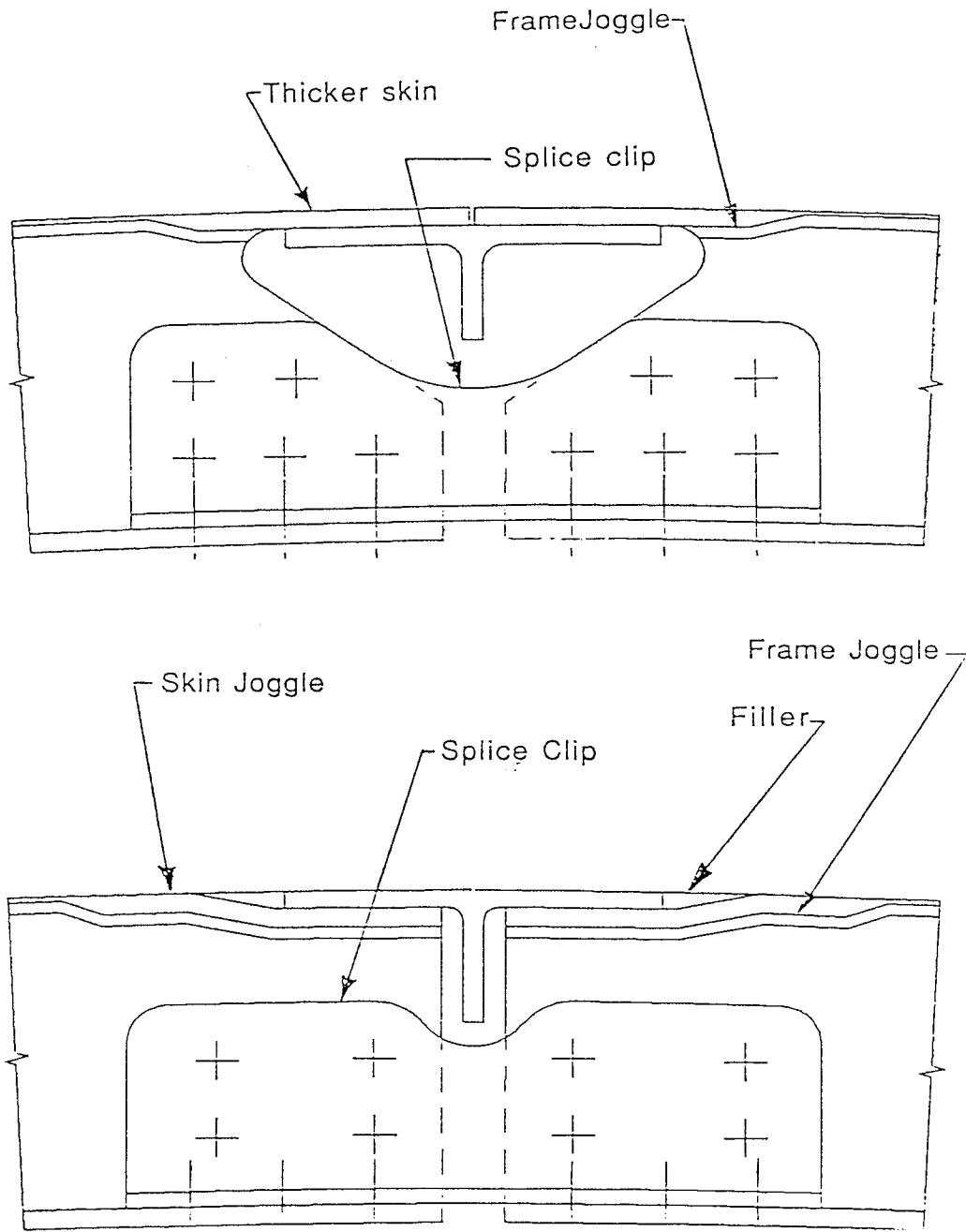

Figure 61, Splice Concepts.

3.2.1 Test Plan-Fuselage Structures

Fuselage element tests, shown in Table 27, were to evaluate different manufacturing approaches and candidate material forms. The

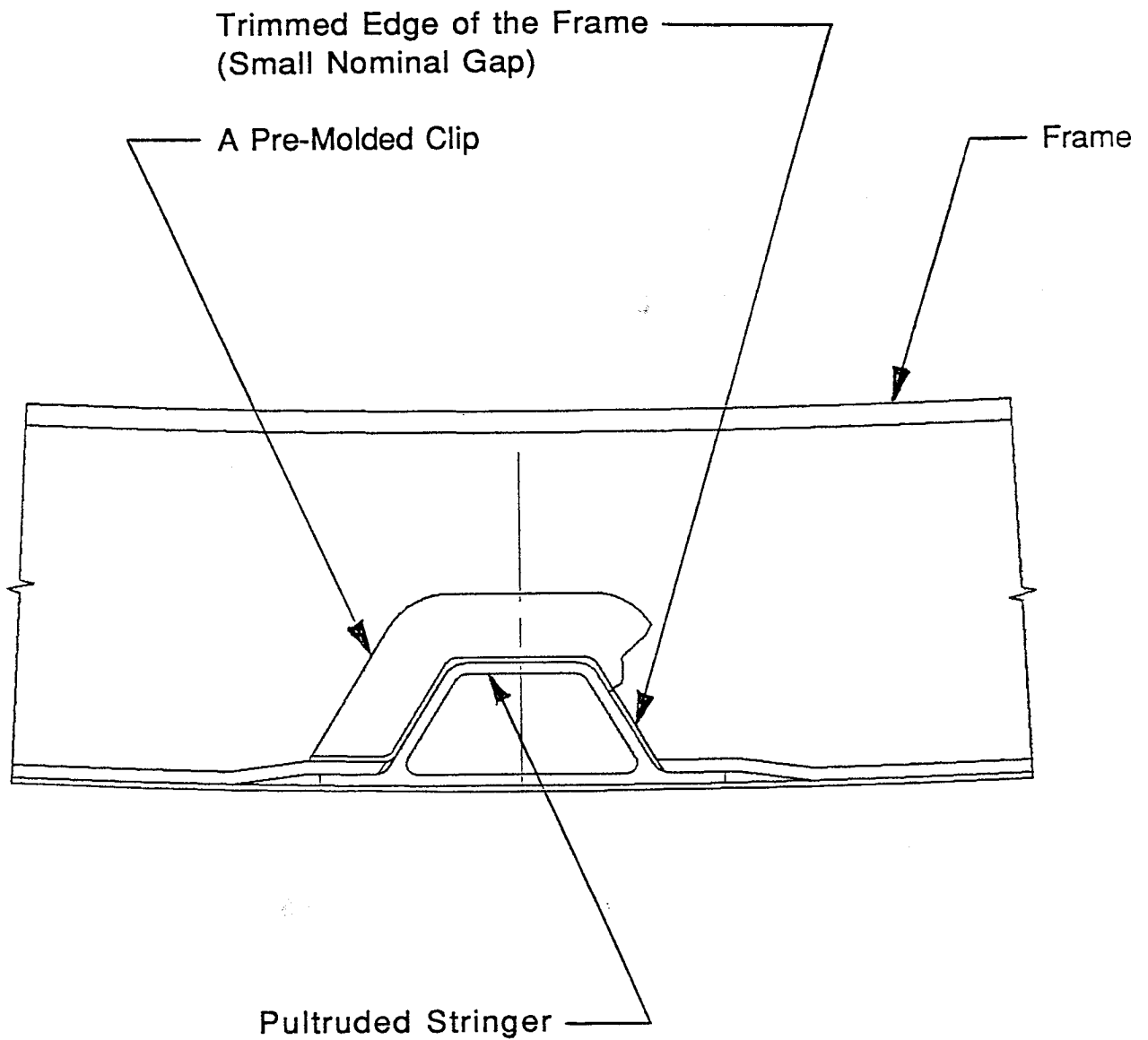

Figure 62, Stringer/Frame Intersection.

fuselage element tests to be conducted were stringer/shell pull-off, frame/shell pull-off, shell/stringer compression and pressure integrity after low velocity impact tests. Stringer/shell pull-off tests evaluate

various configurations of the fuselage shell/stringer joint. The frame/shell pull-off test would determine the structural properties of the co-cured joint. Shell/stringer compression tests were to be used to further validate the shell design and manufacturing concepts. Pressure integrity after low velocity impact tests were designed to demonstrate the effectiveness of the design to sustain in-service impacts.

Using a building block approach, fuselage subcomponent tests were to be conducted following the element tests and were intended to evaluate two configurations for frame bending and three-stringer panels in compression. The shear panel and five-stringer compression panel tests were only to evaluate the most promising configurations. Frame bending tests were to be performed to validate the innovative manufacturing processes proposed for the frames. The three-stringer compression panel tests were designed to evaluate the structural integrity and damage tolerance of the shell design. The shear panel test was to simulate structure with the highest shear loading in the fuselage; panels were to be tested undamaged, damaged and with two lifetimes fatigue with damage. Finally, the five-stringer compression panel, which represents structure in the area of highest compression loading, was to be tested with impact damage in a critical area.

In support of the test plan the first panel design drawing, for the coupon and element test specimens, was initiated. It was planned to fabricate one panel that comprises all of the test specimens. The panel would then be cut to obtain the individual specimens. This activity was halted before completion, however, pending redirection from NASA.

Table 27, Task 1 Fuselage Structure Test Matrix.

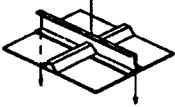
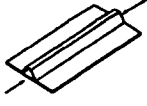
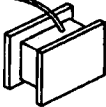
Test	Test Configuration	Specimen Configurations (Replicates)	Total Number Of Tests Planned	Conditions	Instrumentation
Stringer/Shell Pull-off		2 (3)	6	RTD	None
Frame/Shell Pull-off		2 (3)	6	RTD	None
Shell/Stringer Compression		2 (3)	6	RTD	4 Axial Gages
Pressure Integrity After Impact		2 (2)	4	With Low Energy Impact Damage	None

Fuselage Element Tests

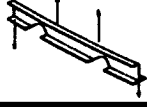
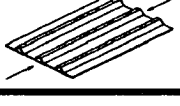
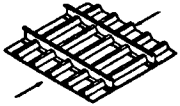
Test	Test Configuration	Specimen Configurations (Replicates)	Total Number Of Tests Planned	Conditions	Instrumentation
Frame Bending		2 (1)	2	4 Point Bending	4 Axial Gages 2 Rosettes
3 Stringer Compression		2 (2)	2 2	Notched With Impact Damage	8 Axial Gages
Shear Panel		1 (3)	1 1 1	Undamaged With Impact Damage 2 Lifetimes Fatigue (Damaged)	4 Axial Gages 4 Rosettes
5 Stringer Compression		1 (1)	1	With Impact Damage	15 Axial Gages

Fuselage Subcomponent Tests

4.0 References

1. A. C. Jackson, "Advanced Composites Structural Concepts and Materials Technologies for Primary Aircraft Structures", presented at the *First NASA Advanced Composite Technology Conference*, at Seattle, WA, October 29-November 1, 1990. NASA CP-3104, pp. 39-70.
2. A. C. Jackson, R. E. Barrie, B. M. Shah and J. G. Shukla, "Advanced Textile Applications for Primary Aircraft Structures", presented at the *Second NASA Advanced Composite Technology Conference*, at Reno, NV, November 4-7, 1991.

REPORT DOCUMENTATION PAGE

Form Approved
OMB No. 0704-0188

Public reporting burden for this collection of information is estimated to average 1 hour per response, including the time for reviewing instructions, searching existing data sources, gathering and maintaining the data needed, and completing and reviewing the collection of information. Send comments regarding this burden estimate or any other aspect of this collection of information, including suggestions for reducing this burden, to Washington Headquarters Services, Directorate for Information Operations and Reports, 1215 Jefferson Davis Highway, Suite 1204, Arlington, VA 22202-4302, and to the Office of Management and Budget, Paperwork Reduction Project (0704-0188), Washington, DC 20503.

1. AGENCY USE ONLY (Leave blank)		2. REPORT DATE September 1992	3. REPORT TYPE AND DATES COVERED Contractor Report (May 89 - May 92)	
4. TITLE AND SUBTITLE Advanced Composites Structural Concepts and Materials Technologies for Primary Aircraft Structures - Design/Manufacturing Concept Assessment			5. FUNDING NUMBERS C NAS1-18888 WU 510-02-13-01	
6. AUTHOR(S) Robert L. Chu, T. D. Bayha, H. Davis, J. E. Ingram, and J. G. Shukla			8. PERFORMING ORGANIZATION REPORT NUMBER 73-C1	
7. PERFORMING ORGANIZATION NAME(S) AND ADDRESS(ES) Lockheed Aeronautical Systems Company Advanced Structures and Materials Division 86 South Cobb Drive Marietta, GA 30063			10. SPONSORING / MONITORING AGENCY REPORT NUMBER NASA CR-4447	
9. SPONSORING / MONITORING AGENCY NAME(S) AND ADDRESS(ES) NASA Langley Research Center Hampton, VA 23681-0001			11. SUPPLEMENTARY NOTES Langley Technical Monitor: Randall C. Davis Task 1 Final Report	
12a. DISTRIBUTION / AVAILABILITY STATEMENT Subject Category 05		12b. DISTRIBUTION CODE		
13. ABSTRACT (Maximum 200 words) Composite Wing and Fuselage Structural Design/Manufacturing Concepts have been developed and evaluated. Trade studies were performed to determine how well the concepts satisfy the program goals of 25% cost savings, 40% weight savings with aircraft resizing and 50% part count reduction as compared to the aluminum Lockheed L-1011 baseline. The concepts developed using emerging technologies such as; large scale RTM, ATP, Braiding, out-of-autoclave and automated manufacturing processes both thermoset and thermoplastic materials were evaluated for possible application in the design concepts. Trade studies were used to determine which concepts carry into the detailed design development subtask.				
14. SUBJECT TERMS Composites, Design/Manufacturing Concepts, Cost, Weights, Down Select, Trade Studies			15. NUMBER OF PAGES 112	
			16. PRICE CODE	
17. SECURITY CLASSIFICATION OF REPORT Unclassified	18. SECURITY CLASSIFICATION OF THIS PAGE Unclassified	19. SECURITY CLASSIFICATION OF ABSTRACT	20. LIMITATION OF ABSTRACT	