

GOMOS -- GLOBAL OZONE MONITORING BY OCCULTATION OF STARS

*G.W. Leppelmeier**
 Technical Research Centre of Finland
 02150 Espoo, Finland

E. Kyrölä and R. Pellinen
 Finnish Meteorological Institute
 00101 Helsinki, Finland

P. Mérat
 Matra Marconi Space France
 31077 Toulouse, France

S. Korpela
 Space Systems Finland
 02150 Espoo, Finland, and

J.L. Bertaux, E. Chassefière, F. Dalaudier, and G. Mégie
 CNRS Service d'Aéronomie
 91731 Verrières-le-Buisson, France

ABSTRACT

In this paper we report on the progress and status of the GOMOS instrument, an imaging spectrometer under development for flight on the European Space Agency's POEM-1 mission in 1998. Employing occultation of stars as a light probe of the Earth's atmosphere from a sun-synchronous polar orbit, the instrument will monitor ozone and other atmospheric trace gases over the entire globe. Atmospheric transmission measurements will be made with an altitude resolution of ~1.7 km. When data are combined regionally, it will be possible to detect ozone concentration trends as small as 0.05%/year, depending on the degree of combination.

INTRODUCTION

Starting with indirect and tentative indications in the late 60's and early 70's, concern has steadily grown about the condition of the layer of ozone in the Earth's upper atmosphere, which provides uv protection to life on the surface. Measurements indicating a growing seasonal decrease in the ozone protection over the South Pole are now generally accepted, as are indicators of a general long-term trend elsewhere.

As one response (of many) to this concern, an instrument, GOMOS, is being developed which will use *occluding stars* to measure the uv and visible attenuation through the atmosphere to estimate the ozone concentration in the upper atmosphere. Onboard a sun-synchronous polar satellite, GOMOS will provide coverage of the whole globe.

THE MISSION

The European Space Agency's Earth Observation Programme is sponsoring the Polar Orbiting Earth Mission, (POEM-1), which focuses on long-term Earth observation. Part of the payload is meteorological, being provided by EUMETSAT. The other part consists of instruments concentrating on the Earth's environmental condition, on the surface and in the atmosphere. In particular, three instruments are concerned with ozone and other trace gases in the atmosphere: SCIAMACHY, MIPAS, and GOMOS. Because each instrument is different, they complement each other in monitoring the atmosphere. POEM-1 is the first of a series of satellites which will offer sustained observation of the Earth's environment over a long period. The first is planned for launch in 1998, with successive launches every 4-5 years.

GOMOS GOALS

Two of the main points about GOMOS are the fact the coverage is global and the precision is good enough to detect long term trends. Because GOMOS observes an occulting star's spectrum through the atmosphere, the measurement is by nature a limb measurement. Because of the imaging spectrometer nature of the instrument, GOMOS works in both bright and dark limb observation. Reliability of the results is enhanced by the fact that the instrument is essentially self-calibrating: the occulting star's unattenuated spectrum is taken above the atmosphere, just before the occultation, and is compared with the

spectra recorded as the star's line-of sight descends through the atmosphere. With some 100-odd possible target stars and the capability of both bright- and dark-limb operation, some 30-50 occultations per orbit can be observed. Coupled with the polar orbit, truly global coverage is possible. When data are combined together for 100 regions distributed about the globe, it is possible to detect trends of ozone concentration greater than 0.15%/year; for 9 lateral bands, 0.05%/year.

Since the imaging time is relatively short (0.25-0.5 second) the results give an altitude profile with a vertical resolution of 1.7 km, which will provide a database for extensive atmospheric chemistry studies.

GOMOS TECHNIQUE

Steered by an active pointing system, GOMOS images the target star on two imaging spectrometers, one operating in the uv and visible, the other in the near infrared, and two photometers. In turn, each spectrometer forms an image on a CCD detector, where one dimension represents the dispersion direction, the other a spatial direction (in this case perpendicular to the horizon). Thus, the spectra above and below the spectrum of the star image allow removal of background signal (i.e., both instrumental noise, such as dark current, and light scattered from the atmosphere), which permits more effective bright limb operation, and enhances the signal considerably under dark limb operation. As POEM-1 progresses around its orbit GOMOS' pointing system keeps it pointed at the star as it descends through the Earth's

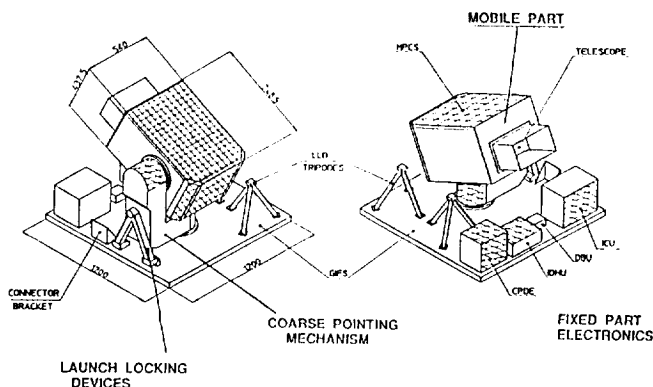

Fig. 1 Instrument Overview

atmosphere at the rate of about 3 km/s.

Because of the index of refraction gradient in the atmosphere, light of different wavelengths will be bent by differing amounts, thus the light recorded at one instant will not have all traveled along the same path (chromatic refraction). While at high altitudes the effect is not important, at 20 km the net angle of refraction differs between uv and red by about 100 μ rad, or about 5 pixels. In order to make proper comparisons in reducing and analyzing the data, one must be able to reconstruct the paths followed by each wavelength. For this reason, two photometer channels have been included, and the absolute pointing history will be recorded, permitting the reconstruction of the deviation of the pointing direction from the straight line to the star during the occultation. With these data and an atmospheric refraction model one will be able to reconstruct the light path as a function of spacecraft position and wavelength.

Attenuation of the star's light has three causes: absorption by trace chemicals (e.g., ozone, oxides of nitrogen, chlorine radicals, etc.), Rayleigh scattering from bulk atmospheric constituents, and scattering from aerosols. In order to obtain the profile of ozone--and possibly other trace gases--a number of things must be known. These include

- the spectrum of the star (taken above the atmosphere),
- absorption cross sections of the gases involved (For ozone, this includes both the Hartley/Huggins and Chappuis bands, the former useful for high altitudes, the latter for low altitudes),

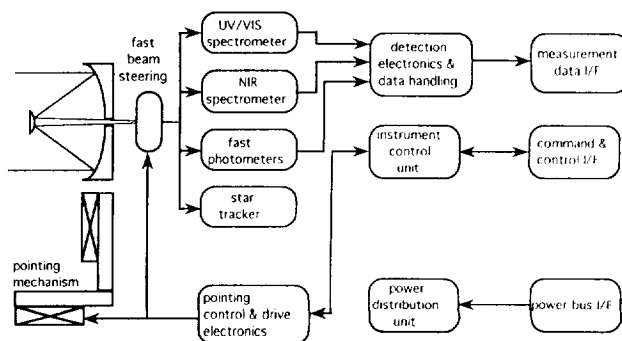

Fig. 2 GOMOS Block Diagram

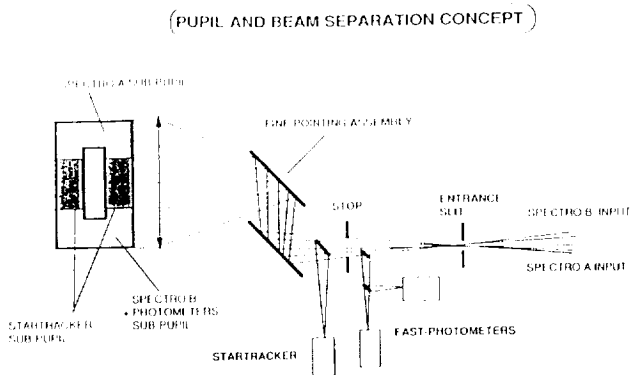

Fig. 3 Pupil and Beam Separation Concept

- the transmission measurement,
- temperature profile (This is needed to evaluate the Ozone absorption cross-section in the Hartley/Huggins band, and is inferred from the measured O₂ profile.),
- the H₂O profile, and
- scintillation measurements (obtained from the two photometers), from which one can obtain a measure of the atmospheric chromatic refraction).

THE INSTRUMENT

Figure 1 shows the overall view of the instrument, consisting of the moving part, containing optics and front-end electronics, and the static part. Figure 2 presents the block diagram of the instrument, with all the major optical subsystems. Figure 3 shows the details of the beam sharing, including the location of the Fine Pointing Assembly. A single 115 cm focal length Cassegrain telescope collects the light for all the channels, which include a uv-visible ("UVIS") imaging spectrometer, an infrared imaging spectrometer, two scintillation photometers, and a star sensor. Table I summarizes the specifications of the optical subsystems.

The UVIS spectrometer operates from 250 to 675 nm and features a concave imaging holographic grating, with a thinned, backside-illuminated CCD detectors. The (static) spectral resolution will be 0.6 nm (FWHM). The pixel spacing of 22 μm represents 0.3 nm in the spectral direction or 19 Érad in the spatial direction. In order to achieve this resolution the

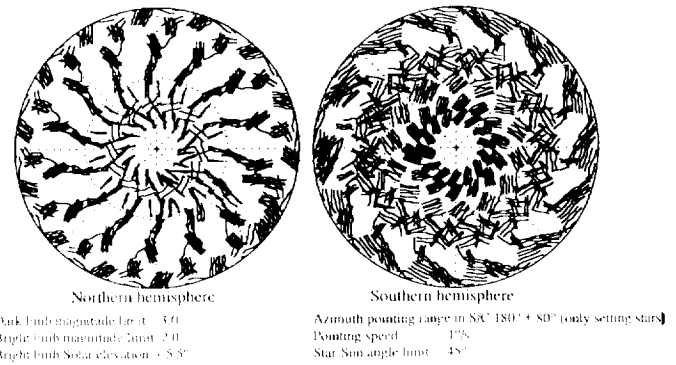

Fig. 4 Coverage for week of 4-10 October

image is distributed to three CCD's by means of a dichroic beamsplitter ("DIVOLI"), with gaps around 400 and 550 nm.

The infrared spectrometer is in a Littrow configuration, with a plane grating and standard silicon CCD detector. A prism, with dispersion crossed with respect to the grating, allows the two bands of interest (756-773 nm, and 926-952 nm) to be imaged on the same CCD detector. The (static) spectral resolution will be 0.12 nm (FWHM).

The two photometer channels (650-700 nm and 470-520 nm) will operate in analog mode, with a 500 khz low pass band. The maximum anticipated flux (per detector) is $\sim 4 \times 10^6$ photons per second.

The pointing system works in three phases: rallying--moving GOMOS so as to bring the target star into the field of view of the star tracker; acquisition--locking the pointing system onto the target star; and tracking--keeping the target star in the middle of the entrance slit, while data from the CCD's and photometers are taken. Since the star image is smaller than the entrance slit, the pointing system must keep the star image at the center of the slit, in order to maintain both spectral and spatial resolution. Control is required to follow the star in occultation (while the spacecraft maintains orientation towards the nadir.) as well as to accommodate uncertainty and variation in the pointing of the spacecraft. The spacecraft pointing accuracy and stability are 0.1° (per axis), with a maximum pointing rate of 0.015°/sec, while the requirement for the instrument is ~ 20 μrad. Thus, a high precision pointing performance is required during the

tracking phase. In order to accomplish these tasks, the pointing system has two parts: the Coarse Pointing Mechanism (CPM), which moves the whole optical part of the instrument, and the Fine Pointing Assembly (FPA), which consists of a pair of small mirrors near the focal plane. The CPM will provide a pointing accuracy of $\sim 0.1^\circ$, with a bandwidth of ~ 2 Hz, while the FPA will provide a pointing accuracy of $\pm 20 \mu\text{rad}$, with a bandwidth of ~ 80 Hz.

COVERAGE

Depending on the location of a star, an occultation measurement, typically from 100 km altitude to 20 km, lasts between 30 and 150 seconds. Allowing for the time to rally to a new target star, and depending on the criterion for selection, some 25-40, or even more, occultations may be observed during one orbit. As there are some 176 stars of visual magnitude 3 or less, it is clear some selection criteria must be applied. Programs have been developed for assembling occultation sequences, depending on input criteria. For example, it is possible to select brightest stars, or next available star, with a sub-criterion, such as location, angle to the Sun, spec-

tral type, etc. In this way a sequence can be tailored to the goals of a particular campaign. For example, Figure 4 shows the coverage of the Earth for the week of 4-10 October, using a visual magnitude limit of 3.0 for dark limb observation and 2.0 for bright limb observation.

SUMMARY

GOMOS is a versatile instrument, which can be used for both long term trend ozone monitoring, as well as for more specific, localized studies. Because it measures the star's spectrum above the atmosphere and records its pointing direction while taking data, it is essentially self-calibrating. In addition, the ir channels and the photometers provide accompanying data to help to evaluate the cross-sections and paths, in order to arrive at the correct line densities and vertical profiles. Using only brighter stars it can obtain very accurate results for monitoring long term trends, or, using dimmer stars, it can yield higher density coverage for regional studies. Combined with results from the other atmospheric instruments it should make a significant contribution to understanding the upper atmosphere.

TABLE I. OPTICAL SYSTEMS DESCRIPTION

characteristic	UVIS spectrometer	IR spectrometer	star tracker	fast photometers
telescope sub-pupil input beam aperture	164 cm ² f/6.8 x f/8.6	164 cm ² f/6.8 x f/8.6	42 cm ² --	164 cm ² --
spectral band	250-675 nm	B1: 756-773 nm B2: 926-952 nm	750-950 nm	VIS1: 470-520 nm VIS2: 650-700 nm
field of view (instrument)	$\pm 0.05^\circ$	$\pm 0.05^\circ$	acquisition: $\pm 0.3^\circ$ tracking: $\pm 200 \mu\text{rad}$	field stop-limited: $\pm 80 \mu\text{rad}$ (0.005°)
field of view (pixel)	$16.5 \mu\text{rad}$	$16.5 \mu\text{rad}$	$100 \mu\text{rad}$	$80 \mu\text{rad}$
focal length	1150 mm	1150 mm	230.5 mm (telescope + relay optics)	736 mm (telescope + relay optics)
disperser	concave holographic grating, Roland mounting	collimator + prism (B1/B2) + plane grating, Littrow mounting	--	--
beam extraction	--	--	folding mirror	2 dichroic beamsplitters
focal plane	3 CCD's: 512 x 512 pixels pixel size: $19 \times 19 \mu\text{m}$ active area: 512 x 40 pixels DIVOLI for routing image onto CCD's	1 CCD: 512 x 512 pixels pixel size: $19 \times 19 \mu\text{m}$ active area: 2 regions, each 512 x 40 pixels	CCD: 288 x 384 pixels active: 108 x 108 pixels pixel size: $23 \times 23 \mu\text{m}$	silicon avalanche photodiodes active area: 500 μm diam.