

DESIGN AND TESTING
OF A MODEL CELSS
CHAMBER ROBOT

1N-37-CR
20/1/16
P.315

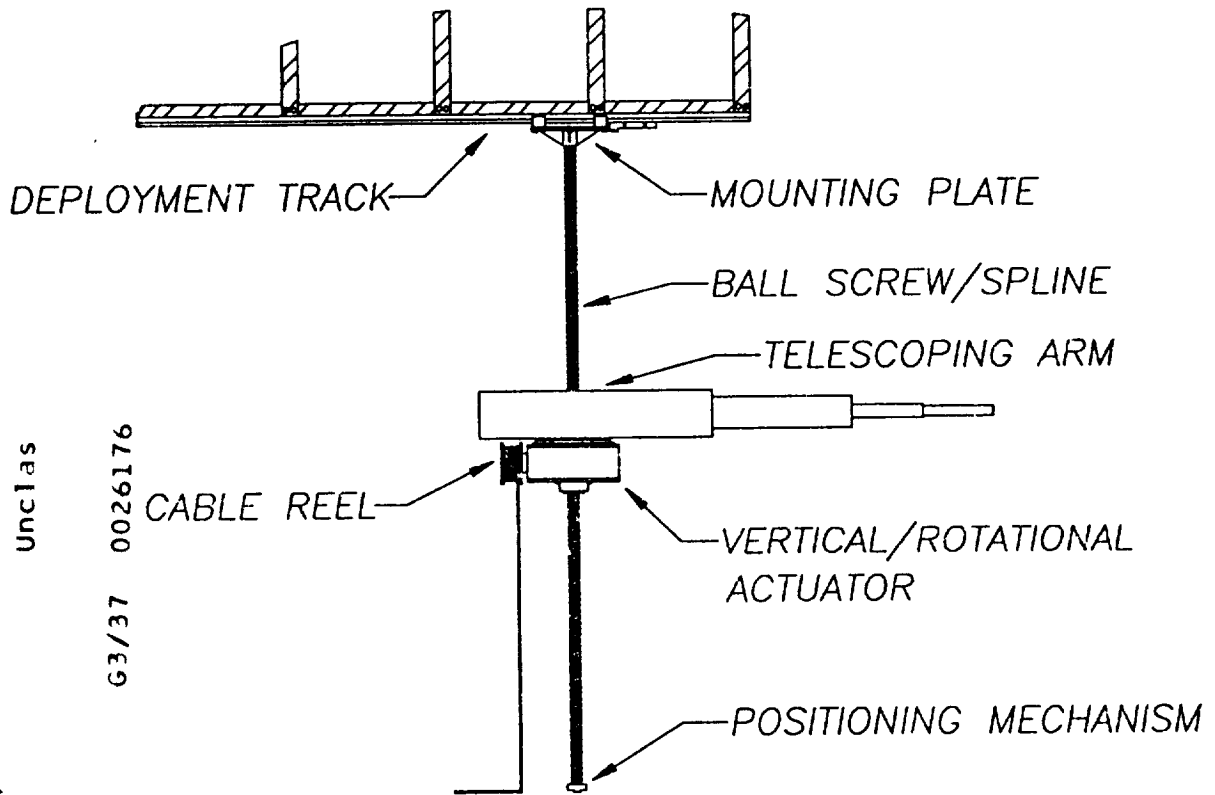

N95-12694

Unclas

G3/37 0026176

(NASA-CR-197196) DESIGN AND
TESTING OF A MODEL CELSS CHAMBER
ROBOT Final Report (University of
Central Florida) 315 p

NASA / USRA FINAL REPORT 1994

UNIVERSITY OF CENTRAL FLORIDA

MECHANICAL AND AEROSPACE ENGINEERING

**DESIGN AND TESTING
OF A MODEL CELSS
CHAMBER ROBOT**

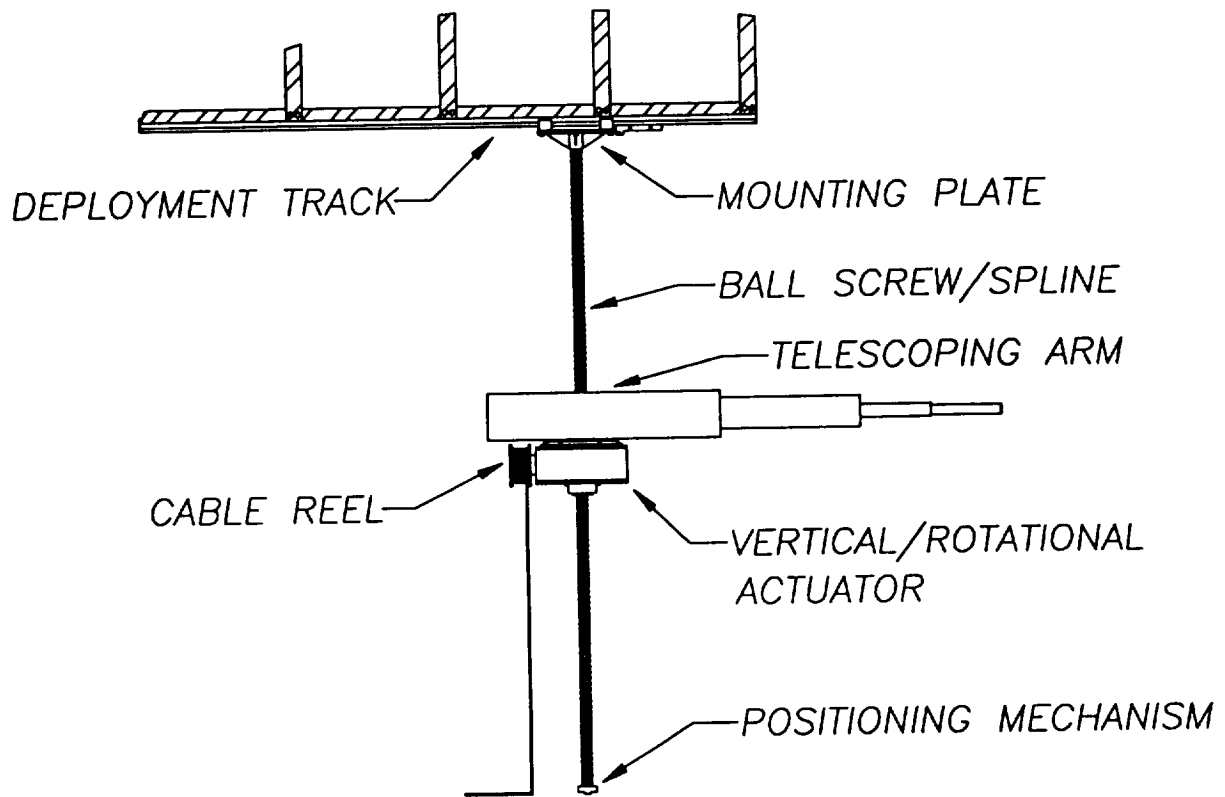

NASA / USRA FINAL REPORT 1994

UNIVERSITY OF CENTRAL FLORIDA

MECHANICAL AND AEROSPACE ENGINEERING

DESIGN AND TESTING OF AN ENVIRONMENTAL SENSING ROBOT

EXECUTIVE SUMMARY

The University of Central Florida's senior Aerospace Engineering design class designed and tested a robot system for use in an enclosed environment. The conceptual design will be used to assist the research performed by the Controlled Ecological Life Support System (CELSS) project. Design specifications for the robot system include maximum load capacity, operation at specified environmental conditions, low maintenance, and safety. The robot system must not be hazardous to the sealed environment, and be capable of stowing and deploying within a minimum area of the CELSS chamber facility.

This design consists of a telescoping robot arm that slides vertically on a shaft which is positioned in the center of the CELSS chamber (Figure 1). The telescoping robot arm consists of a series of links which can be fully extended to a length equal to the radius of the working envelope of the CELSS chamber. The vertical motion of the robot arm is achieved through the use of a combination ball screw / ball spline actuator system. The robot arm rotates cylindrically about the vertical axis through the use of a turntable bearing attached to a central mounting structure which is fitted to the actuator shaft. The shaft is installed in an overhead rail system which allows the entire structure to be stowed and deployed within the CELSS chamber. The overhead rail system is located above the chamber's upper lamps and extends to the center of the CELSS chamber. The mounting interface of the actuator shaft and rail system allows the entire actuator shaft to be detached and removed from the CELSS chamber. When the actuator shaft is deployed, it is held fixed at the bottom of the chamber by placing a square knob on the bottom of the shaft into a recessed square fitting in the bottom of the chamber floor. A support boot ensures the rigidity of the shaft.

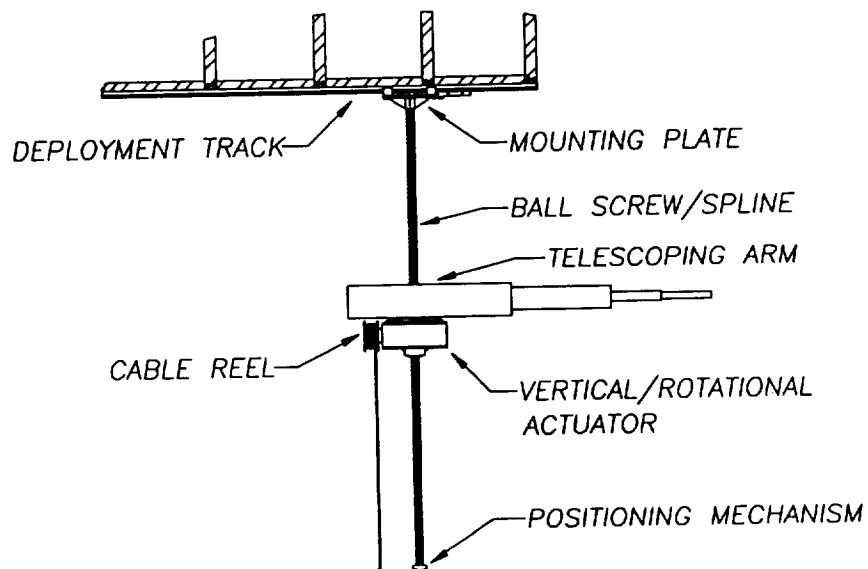

Figure 1 CELSS Robot Design

During the second semester, three teams were combined into one group. The class designed a model of the CELSS chamber robot that could be built by the students. They investigated materials, availability, and strength in their design. Lexan was chosen as the best material to build the links. Polycarbonate cement was used to glue the Lexan sections together to form the telescopic arm. Slider bearings were used to facilitate the sliding motion of the Lexan links. The model stand was built from aluminum and used a steel pipe to allow the telescopic arm to be tested at various heights.

After the model arm and stand were built, the class performed pre-tests on the entire system. A stability pre-test was used to determine whether the model robot arm would tip over on the stand when it was fully extended. Results showed the stand tipped when 50 Newtons were applied horizontally to the top of the vertical shaft while the arm was fully extended. This proved that the stand was stable. Another pre-test was the actuator slip test. This was to determine if there is an adequate coefficient of friction between the actuator drive wheels and the drive cable to enable the actuator to fully extend and retract the arm. This pre-test revealed that the coefficient of friction between the drive wheel and the drive cable was not large enough to prevent slippage. Sandpaper was glued to the drive wheel and this eliminated the slippage problem.

The class performed a fit test in the CELSS chamber. This test was to ensure that the completed robot arm is capable of reaching the entire working envelope of the CELSS chamber. The robot was centered in the chamber. The arm was able to fully extend to the sides of the CELSS chamber. The arm was also able to retract so it cleared the drain pipes that separated the upper and lower plant trays.

Foreword

During the 1993-1994 academic year Aerospace Engineering design students designed and tested a model of an environmental sensing robot. Aerospace Design 4700 and 4710 cater to a variety of design interests of senior aerospace and mechanical engineering students at the University of Central Florida (UCF). The output of the course sequence includes (a) oral design reviews, (b) a working model of the design and (c) a final report containing design information plus results of model construction and testing.

A goal of this year's work, conducted with the Robotics Laboratory in the Controlled Ecological Life Support System (CELSS) facility at Kennedy Space Center (KSC), was to design, build and test a safe robot system that requires low maintenance while operating in a sealed environment. Emphasis was placed on making the robot non-hazardous to the environment and making the robot capable of stowing and deploying within the minimum area of the CELSS chamber facility. The fall semester was spent doing a detailed design of a model robot for testing in the CELSS laboratory. In the spring semester the robot model was built at UCF, and tested at UCF and the CELSS laboratory at Kennedy Space Center. Travel to the KSC test site was accomplished by all students in the class to participate in the testing of the model robot arm for fit and function.

At the end of fall semester a design review was conducted at KSC. At the end of spring semester results of testing the robot model were reviewed at KSC. Comments received from NASA and contractor engineers during this review process have greatly influenced the content of this report and increased the engineering knowledge of the students.

The Advanced Design Program (ADP) robot design team consisted of twenty-three engineering seniors. Nathan Baker served as Graduate Teaching Assistant during both fall and spring semesters. Nathan's efforts coordinating and guiding the interfaces of the designs were invaluable. He had the major task of integrating the design and test reports into this final report. Mark Davis and Mike Patterson made significant contributions to the final report and made the presentations at the summer conference. Nathan Baker is continuing as Graduate Teaching Assistant for the coming academic year. I will be retiring after seven years of association with the fine people of the Advanced Design Program. I will miss seeing my ADP friends and want to wish you all total success in your design endeavors. Dr. Roger Johnson, a friend from yesteryear on the Air Force Academy faculty, will be taking over the ADP at UCF beginning Fall Semester 1994. I am sure you will find Roger a true professional, and a great Space enthusiast and friend, as I have over the years.

We gratefully acknowledge support from NASA, USRA, Bionetics Corporation and Rockwell International in the NASA/USRA Advanced Space Design Program. Gabor Tamasi of the KSC Robotics Laboratory has generously devoted his time guiding the design of a successful robot model in UCF design classes. His comprehensive knowledge made this work possible. Special recognition at KSC is due Sterling Walker, Mechanical Engineering Division Chief; Bill Jones, Advanced Mechanical Systems Branch Chief; Bill Knott, Life Science Research Manager; John Sager, CELSS Research Manager; and Bill Martin, University Relations; for their encouragement and support. At NASA Headquarters in Washington, D.C., special recognition is due Dr. Robert J. Hayduk, Office of Advanced Concepts and Technology; and Sherry McGee, Office of Human Resources and Education. At USRA in Houston special recognition is due John Sevier, Director, Educational Programs; Vicki Johnson, ADP Program Manager; and Barbara Rumbaugh, ADP Senior Project Administrator, for guidance and help. We greatly appreciate the efforts of Dorothy Price and Donna Atkins for guidance and help searching out technical documentation at the KSC library. We are indebted to Greg Opresko, Jim Aliberti, Dennis Matthews, Jose Alonso, Cathy Parker, Bruce Larsen, and Dave Springer for their technical support and encouragement throughout the academic year. For attendance at our design reviews and valuable technical comments we thank Bionetics CELSS engineering lead Russ Fortson, and our Rockwell industry representatives; Suzanne Hodge from the local office, and Scott Johnson and Davoud Manouchehri from Downey, California.

TABLE OF CONTENTS

<u>SECTION I OVERHEAD RAIL SUBSYSTEM</u>		1
Chapter 1.0 INITIAL DESIGNS		3
1.1 INTRODUCTION		3
1.2 REQUIREMENTS		3
1.3 DESIGNS		3
1.3.1 Telescoping Robot		3
1.3.2 Scissor Link Robot		4
1.3.3 Track Following Robot		7
1.3.4 Three Link Arm		9
1.3.5 Supported Two Link Arm		11
1.3.6 Overhead Beam Robot		14
Chapter 2.0 FINAL DESIGN		16
2.1 INTRODUCTION		16
2.2 SUB-SYSTEM REQUIREMENTS		16
2.3 SUB-SYSTEM DESCRIPTION		17
2.3.1 Hardware Description		17
2.3.1.1 Rail Assembly		17
2.3.1.2 Carriage Assembly		17
2.3.1.3 Mounting		17
2.3.1.4 Bearings		22
2.3.1.5 Positioning Mechanism		22
2.3.1.6 Stowed End Stop		22
2.3.1.7 Braking Mechanism		22
2.3.1.8 Ball Screw Interface Plate		25
2.3.2 Installation		25
2.3.3 Deployment		27
2.3.4 Kinematic Analysis		27
2.3.5 Stress Analysis		27
2.3.6 Vibration		29
2.3.7 Maintenance		30
2.3.8 Safety		30
2.4 SUMMARY		30
Chapter 3.0 OBSERVATIONS AND RECOMMENDATIONS		31
Chapter 4.0 ACKNOWLEDGEMENTS		31
<u>SECTION II VERTICAL SHAFT SUB-SYSTEM</u>		33
Chapter 5.0 INTRODUCTION		35
5.1 OVERVIEW OF DESIGN		35
Chapter 6.0 POSSIBLE DESIGN SOLUTIONS		37
6.1 TRACK DRIVEN ROBOT		37
6.2 POLE MOUNTED ROBOT		39
6.3 CABLE ROBOT		41
6.4 LEG MOUNTED ROBOT		43
6.5 LINK MOUNTED ROBOT		43
6.6 TELESCOPING LINK MOUNTED ROBOT		45

	6.7	DUAL ARM WALL MOUNTED ROBOT	48
Chapter 7.0		DETAILED COMPONENT DESCRIPTIONS	49
	7.1	PROJECT DELINEATION	49
	7.2	BASIC DESCRIPTION	50
	7.3	DETAILED COMPONENT DESCRIPTIONS	50
	7.3.1	Combination Ball Screw / Ball Spline Shaft	50
	7.3.2	Central Mounting Structure	52
	7.3.3	Ball Screw Nut	52
	7.3.4	Ball Spline Nut	57
	7.3.5	Turntable Bearing	57
	7.3.6	Lower Support Boot	57
	7.3.7	Cable Reel	57
Chapter 8.0		ANALYSIS OF DESIGN	60
Chapter 9.0		OBSERVATIONS AND RECOMMENDATIONS	62
Chapter 10.0		ACKNOWLEDGEMENTS	63
<u>SECTION III TELESCOPIC ARM SUB-SYSTEM</u>			65
Chapter 11.0		INTRODUCTION	67
Chapter 12.0		DESIGN PHASE	67
	12.1	FLOOR MOUNTED, FIXED AND TELESCOPIC ARM	67
	12.2	FIXED POLE MOUNT, FIXED TELESCOPIC ARM	70
	12.3	SCISSOR CEILING DESIGN	70
	12.4	RACK AND PINION CEILING DESIGN	73
	12.5	CENTER SCREW COLUMN DESIGN	73
	12.6	TELESCOPIC, PULLEY CEILING DESIGN	76
	12.7	FLOOR MOUNTED TRACK DESIGN	77
	12.8	CENTER COLUMN WITH SIDE WALL STORAGE	79
	12.9	CEILING MOUNTED, FIXED TELESCOPING ARM	79
	12.10	CENTERED WALL MOUNTED TRACKS	84
	12.11	LOW WALL MOUNTED TRACK	87
	12.12	CEILING MOUNTED TRACK	87
	12.13	TOP MOUNTED PULLEY WITH MULTIPLE ARMS	90
Chapter 13.0		FINAL DESIGN	90
	13.1	COORDINATION WITH OTHER GROUPS	90
	13.2	CRITICAL PARTS ANALYSIS	92
	13.2.1	Work Envelope	92
	13.2.2	Telescopic Sections and Overlap	92
	13.2.3	Rollers	94
	13.2.4	Trip Mechanism	94
	13.3	MATERIAL CONSIDERATION AND SELECTION	95
	13.4	VENDOR SELECTION	96
	13.5	LINEAR ACTUATOR SYSTEM	96
	13.6	TRIP MECHANISM	98
	13.7	TELESCOPIC ARM ROLLERS AND BEARINGS	98
	13.8	STATIC AND KINEMATIC ANALYSIS	99
	13.9	DYNAMIC ANALYSIS	100
Chapter 14.0		OBSERVATIONS AND RECOMMENDATIONS	101

Chapter 15.0	ACKNOWLEDGEMENTS	102
SECTION IV	CONSTRUCTION OF TELESCOPIC ARM	103
Chapter 16.0	CONSTRUCTION	105
16.1	MATERIALS	105
16.2	ADHESIVES	108
16.2.1	Polycarbonate Cement	108
16.2.2	Cost	109
16.2.3	Availability	109
16.2.4	Assembly of the Arm Components	109
16.3	SLIDER BEARINGS	114
16.3.1	Slider Bearing Installation	114
16.4	ACTUATOR	115
16.4.1	Actuator Arm Extension	115
16.4.2	Mounting Bracket	119
16.4.3	Drive Channel	121
16.4.4	Winding Assembly	121
16.5	MODEL STAND	125
16.6	AESTHETICS	130
Chapter 17.0	SCHEDULING	131
17.1	LOGIC CHART	131
17.2	GANTT CHART	132
SECTION V	REDESIGN OF ROBOT	139
Chapter 18.0	REDESIGN OF ACTUAL CELSS ROBOT	141
18.1	INTRODUCTION	141
Chapter 19.0	ROBOT ARM CROSS SECTION ANALYSIS	141
19.1	INTRODUCTION	141
19.2	OBSERVATIONS AND RECOMMENDATIONS	143
Chapter 20.0	BEARINGS	144
20.1	INTRODUCTION	144
20.2	VENDOR SELECTION	144
20.3	BEARING DESCRIPTION	144
20.4	MATERIAL PROPERTIES	146
20.5	MOUNTING	146
20.6	EXTENSION AND OVERLAP	146
20.7	SLIDE BEARING ANALYSIS	146
20.8	OBSERVATIONS AND RECOMMENDATIONS	149
Chapter 21.0	ACTUATOR	153
21.1	TELESCOPIC ACTUATOR	153
21.2	DRIVE MECHANISM	153
21.3	TAKE-UP REEL	153
21.4	INTEGRATION	156
21.5	COST	156
21.6	WEIGHT	156
21.7	OBSERVATIONS AND RECOMMENDATIONS	156
Chapter 22.0	SEQUENCING	159
22.1	INTRODUCTION	159

	22.2	ROLLER BALL PLUNGER	159
	22.3	SEQUENCING BY PLUNGER MECHANISM	162
	22.4	VENDOR	163
	22.5	OBSERVATIONS AND RECOMMENDATIONS	163
Chapter 23.0		BELLOWS	163
	23.1	INTRODUCTION	163
	23.2	OPERATIONAL EFFECTS	165
		23.2.1 Central Shaft Bellows	165
		23.2.2 Tapered Arm Bellow	165
	23.3	OBSERVATIONS AND RECOMMENDATIONS	165
Chapter 24.0		DUAL "V" GUIDE SYSTEM	168
	24.1	INTRODUCTION	168
	24.2	STEEL TRACKS	168
	24.3	PRECISION GUIDE WHEELS	170
	24.4	INTERNAL GEAR	170
	24.5	SPUR GEAR	170
	24.6	DUAL "V" GUIDE SYSTEM ANALYSIS	170
	24.7	OBSERVATIONS AND RECOMMENDATIONS	171
Chapter 25.0		CABLE REEL DESCRIPTION	172
	25.1	INTRODUCTION	172
	25.2	CABLE REEL	174
	25.3	OBSERVATIONS AND RECOMMENDATIONS	174
Chapter 26.0		BALL SCREW INTERFACE PLATE	174
	26.1	INTERFACE PLATE	174
	26.2	REMOVAL PLATE	177
	26.3	BRAKING MECHANISM	177
	26.4	OBSERVATIONS AND RECOMMENDATIONS	177
Chapter 27.0		STRESS AND DEFLECTION ANALYSIS	179
	27.1	INTRODUCTION	179
	27.2	I-DEAS COMPUTER ANALYSIS PROGRAM	179
	27.3	MODELING DESCRIPTION	179
	27.4	RESULTS OF COMPUTER ANALYSIS	180
	27.5	VERIFICATION	180
	27.6	OBSERVATIONS AND RECOMMENDATIONS	183
		SECTION VI TEST PLAN	185
Chapter 28.0		FACILITY LOCATIONS	187
Chapter 29.0		TESTING GOALS	187
Chapter 30.0		PRE-TESTING OBJECTIVES AND PROCEDURES	187
	30.1	CENTER OF GRAVITY TEST	187
	30.2	STABILITY TEST	188
	30.3	SAFETY TEST	188
	30.4	CRACK TEST	189
	30.5	LOAD TEST	189
	30.6	PRE-FIT TEST	190
	30.7	CUT TEST	190
	30.8	STAND ATTACHMENT TEST	191

30.9	SHARP EDGE TEST	191
30.10	CABLE REEL SPRING TEST	192
30.11	COLLAPSIBILITY TEST	192
30.12	AESTHETICS TEST	193
30.13	ROTATION TEST	193
30.14	CABLE REEL ACTUATION TEST	193
30.15	MOUNTING BRACKET TEST	194
30.16	ACTUATOR ARM EXTENSION TEST	194
30.17	ADHESIVE TEST	195
30.18	DIMENSIONING TEST	198
30.19	HOLE ALIGNMENT TEST	198
30.20	ACTUATOR SLIP TEST	199
30.21	SLIDE BEARING TEST	200
30.22	REQUIRED TRAVEL ACTION TEST	201
30.23	STAND LOADING TEST	202
30.24	ARM WEIGHT TEST	203
Chapter 31.0	TESTING PROCEDURE AND OBJECTIVES	206
31.1	KENNEDY LEVEL TEST	206
31.2	DEFLECTION TEST	206
31.3	FIT TEST	207
SECTION VII TEST RESULTS		209
Chapter 32.0	PRE-TESTING OBJECTIVES AND RESULTS	211
32.1	CENTER OF GRAVITY	211
32.2	STABILITY TEST	211
32.3	SAFETY TEST	211
32.4	CRACK TEST	212
32.5	PRE-FIT TEST	212
32.6	CUT TEST	212
32.7	STAND ATTACHMENT TEST	213
32.8	SHARP EDGE TEST	213
32.9	CABLE REEL SPRING TEST	214
32.10	COLLAPSIBILITY TEST	214
32.11	AESTHETICS TEST	214
32.12	ROTATION TEST	215
32.13	CABLE REEL ACTUATION TEST	215
32.14	MOUNTING BRACKET TEST	215
32.15	ACTUATOR ARM EXTENSION TEST	215
32.16	ADHESIVE TEST	215
32.17	DIMENSIONING TEST	216
32.18	ACTUATOR SLIP TEST	217
32.19	ATTACHMENT OF SLIDE BEARING PRE-TEST	218
32.20	ATTACHMENT OF SLIDER BEARING TEST	219
32.21	REQUIRED TRAVEL OF BEARING PRE-TEST	219
32.22	REQUIRED TRAVEL ACTION OF BEARING TEST	220
32.23	STAND LOADING TEST	221

Chapter 33.0	TESTING PROCEDURE AND OBJECTIVES	221
33.1	KENNEDY LEVEL TEST	221
33.2	DEFLECTION TEST	221
33.3	FIT TEST	222
SECTION VIII	SUMMARY	225
	SUMMARY	227
	REFERENCES	229
APPENDICES		231
APPENDIX A	SPECIFICATION UCF-SPEC-293	233
APPENDIX B	SPECIFICATION UCF-SPEC-193	245
APPENDIX C	TORQUE AND SPEED DETERMINATION	269
APPENDIX D	COST ESTIMATES	275
APPENDIX E	WEIGHT ESTIMATES	279
APPENDIX F	SPECIFICATIONS UCF-SPEC-393	283
APPENDIX G	STATIC ARM DEFLECTIONS UNDER LOAD	297
APPENDIX H	CALCULATIONS FOR ROLLING FRICTION	301
APPENDIX I	SHEAR FORCE AND MOMENT SPREADSHEET	305
APPENDIX J	COMPARISON OF TORSIONAL RESISTANCE	309
APPENDIX K	CALCULATIONS FOR ALLOWABLE LOAD	313
APPENDIX L	SUMMARY OF COMPUTER ANALYSIS	317
APPENDIX M	DATA FROM COMPUTER ANALYSIS	321

PROJECT PARTICIPANTS

Instructor: Dr. Loren A. Anderson

Graduate Student Project Manager: Nathan E. Baker

Overhead Rail Team

Mark Davis
Shawn DeZego
Kinzy Jones
Christopher Kewley
Mike Langlais
John McCarthy
Damon Penny

Vertical Shaft Team

Tom Bonner
C. Ashley Funderburke
Ruth Hailey
Bart McPeak
Nathaniel Ramos
Michael Silva

Telescopic Arm Team

Charles Asher Adams, III
Joseph T. DeLai
Beth Doty
Joseph Dwyer
Michael Patterson
Angel Polanco
Seo Yi

Buiding and Testing Team

Mark Davis
Joseph DeLai
Shawn DeZego
Joseph Dwyer
C. Ashley Funderburke
Ruth Hailey

Kinzy Jones
Chris Kewley
Mike Langlais
John McCarthy
Bart McPeak
Sherwin Mendoza

Michael Patterson
David Poole
George Rausch
Nathaniel Ramos
Michael Silva

SECTION I

OVERHEAD RAIL SUB-SYSTEM

CONCEPTUAL DESIGN

- * REQUIREMENTS
- * TELESCOPING ROBOT
- * SCISSOR LINK ROBOT
- * TRACK FOLLOWING ROBOT
- * THREE LINK ARM
- * SUPPORTED TWO LINK ARM
- * OVERHEAD BEAM ROBOT

FINAL DESIGN

- * RAIL ASSEMBLY
- * CARRIAGE ASSEMBLY
- * MOUNTING
- * BEARINGS
- * POSITIONING MECHANISM
- * BRAKING MECHANISM
- * BALL SCREW INTERFACE PLATE
- * STRESS ANALYSIS
- * OBSERVATION AND RECOMMENDATIONS

Chapter 1.0 INITIAL DESIGNS

1.1 INTRODUCTION

The Controlled Ecological Life Support System (CELSS) project was established by the Kennedy Space Center (KSC) to study the effects of atmospheric changes on plant growth¹. The project is conducted on site at Cape Canaveral Air Force Station in a large cylindrical vacuum vessel. The cylinder is divided into two chambers, an upper and a lower. A robot model was designed to deliver a payload to specific locations within the upper chamber.

The robot model is capable of delivering its payload to any point in the sealed chamber, thus preventing the necessity for human intervention while an experiment is in progress. The robot model is capable of operation for the duration of sealed chamber experiments. The operation of the robot model does not alter nor damage the chamber structure, environment, or growth of the crops. The specification can be seen in Appendix A.

1.2 REQUIREMENTS

The following are the design requirements for the CELSS robot²:

1. While not in use, the robot shall be stowable to avoid unduly affecting experiments and to allow personnel free access to the chamber in between growth cycles.
2. The robot shall not alter the chamber environment.
3. Robot shall demonstrate adequate flexibility to reach any point in the chamber.
4. The robot shall be capable of supporting a 15 kg payload at the end effector.
5. Robot installation shall minimize modification to the CELSS chamber.
6. Robot shall conform to design standards required for KSC and military projects.
7. SI measurements will be used in design.
8. Robot shall function through all possible CELSS environmental conditions

1.3 DESIGNS

1.3.1 Telescoping Robot

1.3.1.1 Description

The telescoping robot (Figure 1.3.1.1.1) is a ceiling mounted design which achieves vertical motion through a telescoping body. Attached to the end of the vertical body, a horizontal telescoping arm will be used to deploy the end effector. When stowing, the arm and body retract to the ceiling (Figure 1.3.1.1.2).

1.3.1.2 Advantages

As the design employs only three degrees of freedom, the deployment of the payload can be accomplished in a quick and simple manner^{3,4}. The linear motion of actuators eliminates pinch points⁵. The lack of complexity in the design results in a simple control system. When stowed, both telescoping arms will be fully retracted and the robot will fit in a small space near the roof. Installation involves mounting the robot to the chamber roof with minimal modification to chamber.

1.3.1.3 Disadvantages

Due to long links and lack of lateral support, the robot may be susceptible to vibration⁶. As the horizontal actuator can only move radially from the center of the tank, access to areas in the center of the tank would be limited by the contracted length of the telescoping links. The same applies for access to the very top of the tank, which would be limited by the vertical link. The telescoping arms must also be designed without lubrication or hydraulic actuation that can effect chamber environment. Safety becomes important with any design which is attached to the ceiling due to a possible failure of a critical part which could result in damage to the chamber.

1.3.1.4 Feasibility

The practicality of the design depends largely upon the commercial availability of telescoping links. If the links are not available, their custom design and manufacture may be expensive. Since lubrication may effect the closed atmosphere of the chamber, this may present a problem in the design.

1.3.2 Scissor Link Robot

1.3.2.1 Description

The robot is mounted to the center of the chamber ceiling (Figure 1.3.2.1.1). Vertical motion is provided by the deployment of scissor links, which retract to stow near the ceiling (Figure 1.3.2.1.2), while angular motion is accomplished by a rotating actuator at the end of the scissor links. A telescoping arm extends from the rotating actuator and enables access to desired points.

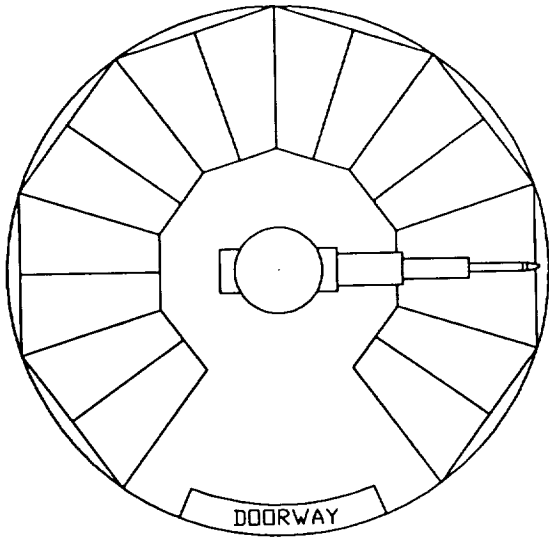

Figure 1.3.1.1.1 Telescoping Robot

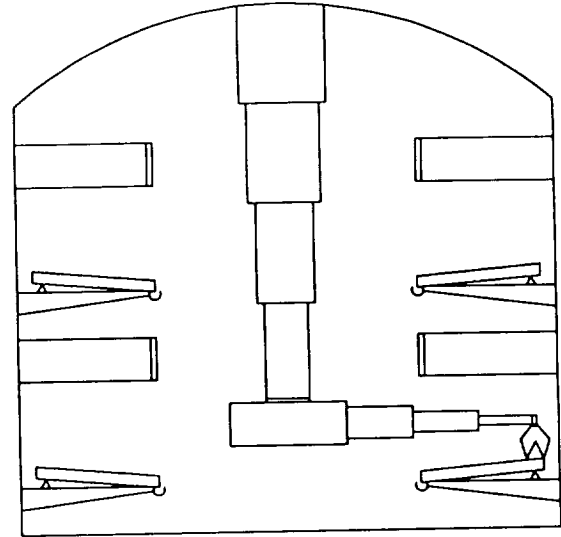

Figure 1.3.1.1.1 Telescoping Robot

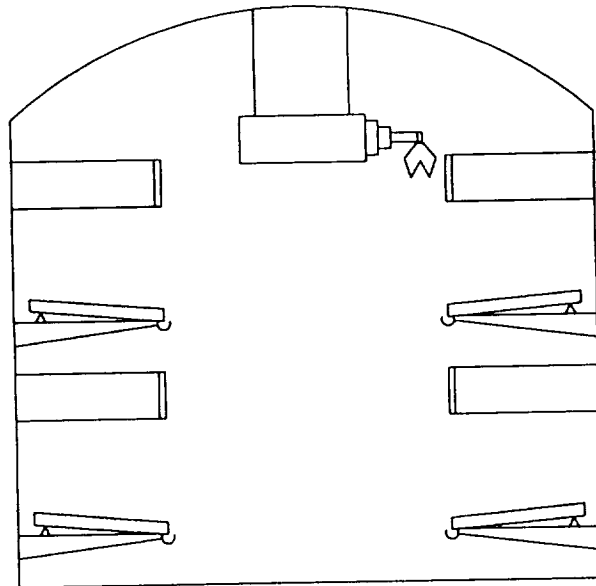

Figure 1.3.1.1.2 Telescoping Robot Stowed

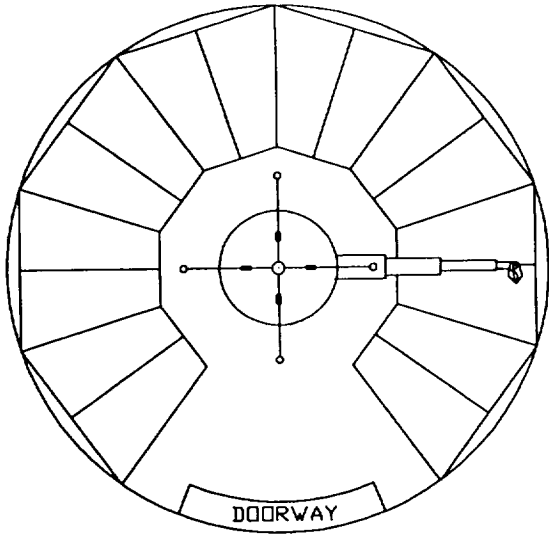

Figure 1.3.2.1.1 Scissor Link Robot

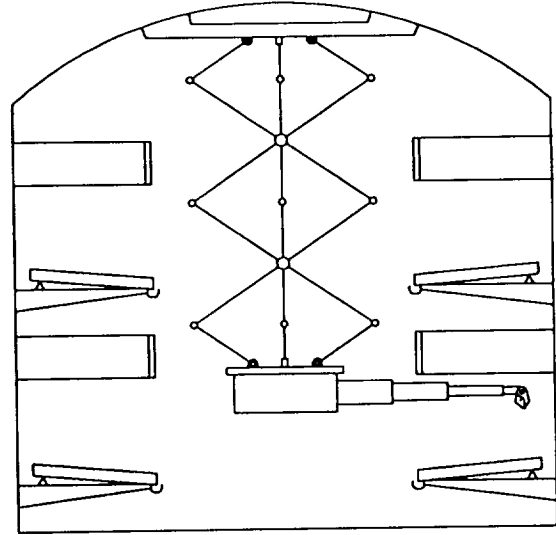

Figure 1.3.2.1.1 Scissor Link Robot

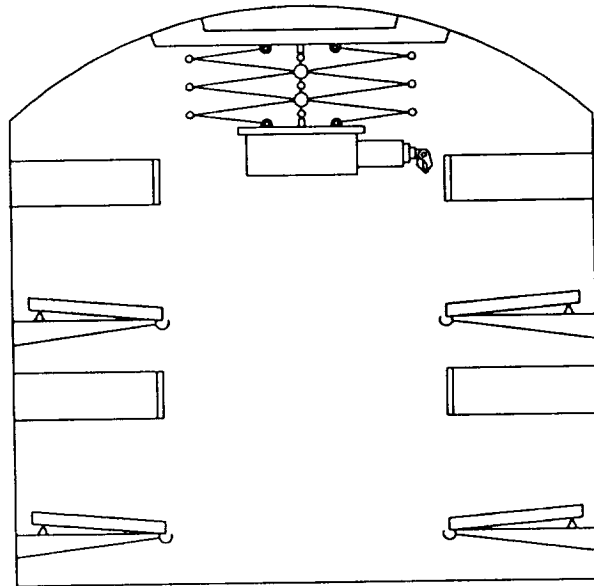

Figure 1.3.2.1.2 Scissor Link Robot Stowed

1.3.2.2 Advantages

Deployment of the scissor links gives quick and flexible access to the tray area. The design includes redundant links for added stability and safety. The retracting of the scissor links allows the robot to fold into a compact position near the ceiling. Because of its compact, stowed position, personnel may access the chamber without robot interference.

1.3.2.3 Disadvantages

The system is complex due to the configuration of the moving links. When fully extended, this design may be insufficient to provide adequate support. Due to the size of the folded scissor links, access to areas near the top of the chamber may be obstructed. The design will create pinch points when folding, reducing the safety.

1.3.2.4 Feasibility

Actuation of scissor links may prove too complex for practical design. The four links of each section must move together exactly to prevent binding. The link size required for a stable system may be impractical.

1.3.2.5 Hybrids

The rotating actuator may be placed at the ceiling mount to for increased stability and simplification of wiring.

1.3.3 Track Following Robot

1.3.3.1 Description

A track will be installed horizontally around the tank in between the two shelf levels. The radius of the track will match the inside of the trays. Deployment of the payload will be accomplished by a two link arm which moves along the track (Figure 1.3.3.1.1). The outer link is supported by double actuation. Robot will stow at the end of the shelf and not inhibit access to the center of the chamber (Figure 1.3.3.1.2).

1.3.3.2 Advantages

Due to the proximity to the shelves and the central location of the track, the lengths of the links may be compact. This compactness will provide greater stability at the payload and require lighter links. The central location will allow quick deployment of the payload. The control of the robot will be aided by the use of existing technology for the two link arm and the location. The design of a redundant link arm will increase safety.

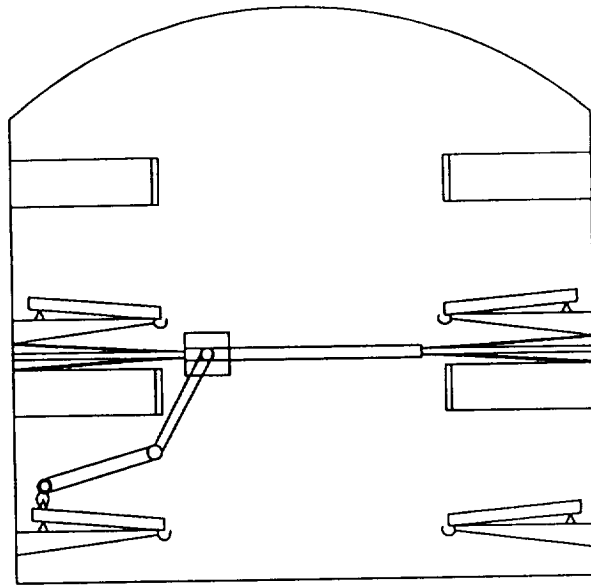

Figure 1.3.3.1.1 Track Following Robot

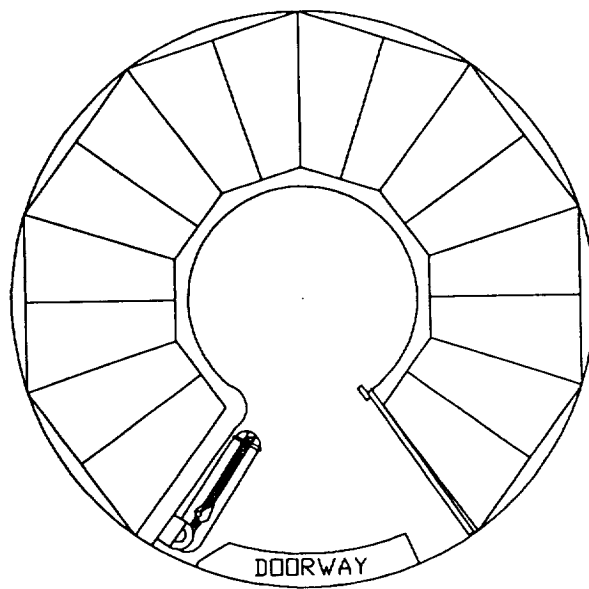

Figure 1.3.3.1.2 Track Following Robot

1.3.3.3 Disadvantages

Installation of the Track Following Robot may require extensive modification to the CELSS chamber and may alter the chamber environment. Exposed wiring of the track follower may also prove undesirable. The compact nature of the robot may prevent access to the upper and lower reaches of the chamber. Debris in the track may hinder movement.

1.3.3.4 Feasibility

The installation of the track may prove impractical due to conflict with existing chamber hardware. The custom fabrication of the track may be too expensive to be practical.

1.3.3.5 Hybrids

A multiple level track system would allow for greater access to the extremes of the chamber. A switching device would be required to transfer the robot between tracks. This would result in increased difficulty of installation, complexity, and cost.

1.3.4 Three Link Arm

1.3.4.1 Description

The robot will be mounted to the center of the tank roof (Figure 1.3.4.1.1) and will use a rotating actuator at the roof for angular motion. A three link arm will then deploy the payload to the desired location. The arms will be slotted to fold inside one another when stowed (Figure 1.3.4.1.2). The folded arms stow along the roof.

1.3.4.2 Advantages

The Three Link Arm will provide adequate flexibility to reach any point in the chamber and may allow movement over obstacles. Due to the slotted arms, the robot will stow to a small volume near the roof to allow access to the chamber. As this design is commonly used, existing technology may be incorporated to minimize cost and custom fabrication of components. The redundant arm design will increase strength and improve safety.

1.3.4.3 Disadvantages

The complexity of this design will increase the difficulty of control and increase the chance of damage to the chamber. The lack of support of the robot at full deployment may result in additional instability and vibration during robot motion. Due to the bulk of the system, deployment will be slow, and the movement of the robot may create pinch points.

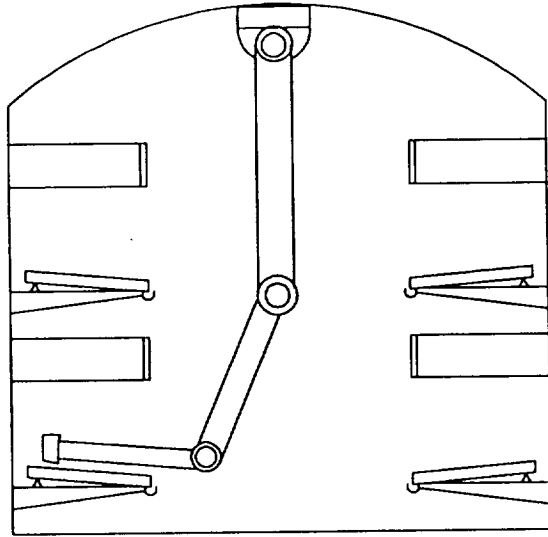

Figure 1.3.4.1.1 Three Link Arm

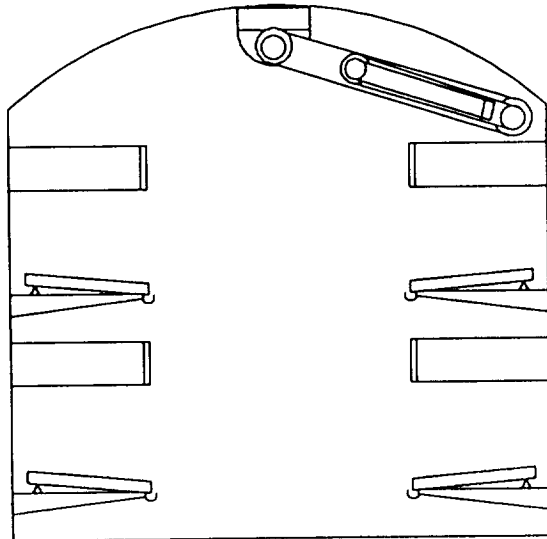

Figure 1.3.4.1.2 Three Link Arm Stowed

1.3.4.4 Feasibility

The use of existing technology makes this design favorable in terms of design effort and cost. Existing software may be used to simplify control. The increased chance of damage may make this design impractical.

1.3.4.5 Hybrids

Slotted links which allow translation of the actuators along their length (Figure 1.3.4.5.1) will increase ease of deployment. Stability will be increased when the actuators are not fully extended along the links. The system will stow near the roof by folding the slotted links (Figure 1.3.4.5.2).

1.3.5 Supported Two Link Arm

1.3.5.1 Description

The robot is mounted to the center of the chamber ceiling (Figure 1.3.5.1.1). A telescoping vertical shaft deploys a stabilizing support to the floor and a two link arm to the center of the chamber. An actuator at the ceiling rotates the entire vertical shaft and the two link arm deploys to the desired position. The outer link is supported by double actuation. When stowed, the vertical shaft is retracted fully and the arm folds against the ceiling (Figure 1.3.5.1.2).

1.3.5.2 Advantages

The extended support will enhance the stability, strength, and safety. As the design employs a minimal number of degrees of freedom, deployment can be accomplished in a quick and simple manner. The simple design will make control simple. The two link arm can make use of existing technology. The use of a redundant outer link will increase the safety.

1.3.5.3 Disadvantages

The bulk of the telescoping shaft and support will decrease stowability. As the length of the two link arm is limited by practical considerations, access to the upper and lower limits of the chamber may be limited. The bulk of the design will create a potential hazard even when stowed. The movement of the two link arm may create pinch points which will decrease the safety.

1.3.5.4 Feasibility

The practicality of the design depends largely upon the commercial availability of telescoping links. If the links are not available, their custom design and manufacture

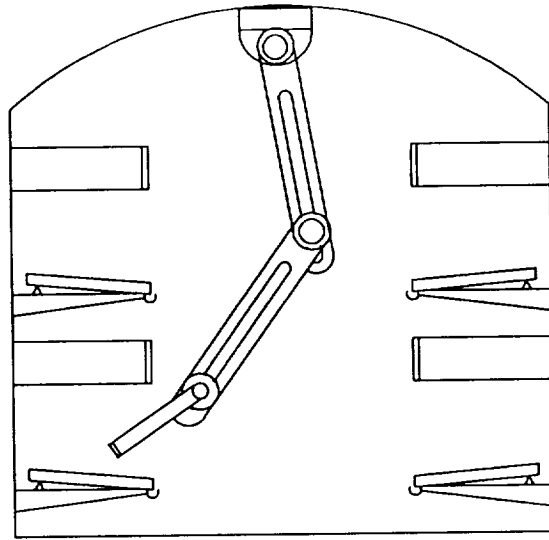

Figure 1.3.4.5.1 Three Link Arm Hybrid

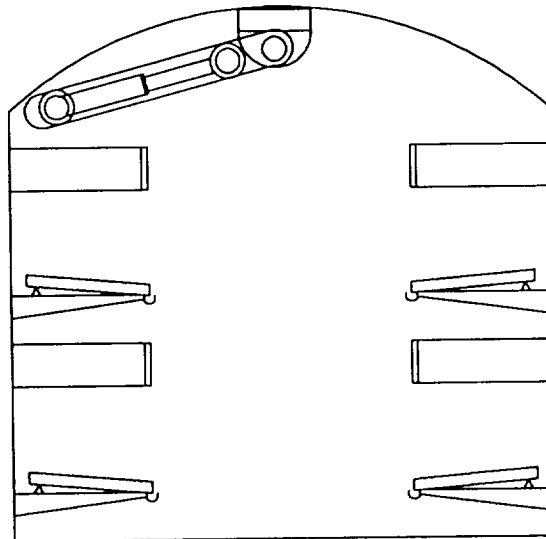

Figure 1.3.4.5.2 Three Link Arm Hybrid

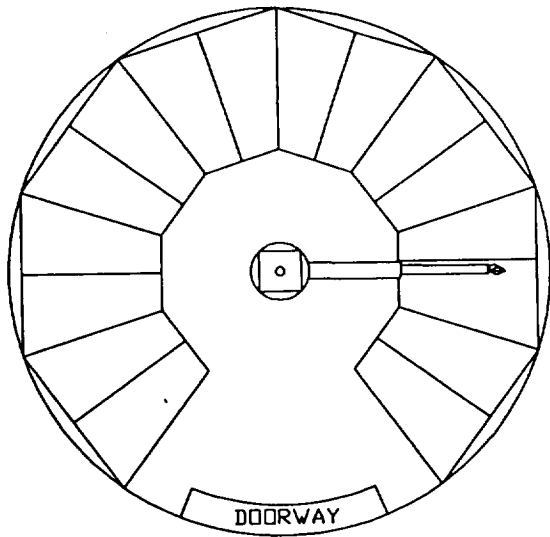

Figure 1.3.5.1.1 Supported Two Link Arm

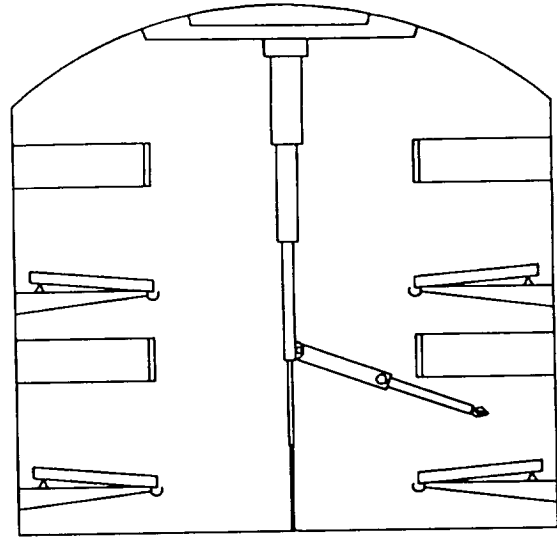

Figure 1.3.5.1.1 Supported Two Link Arm

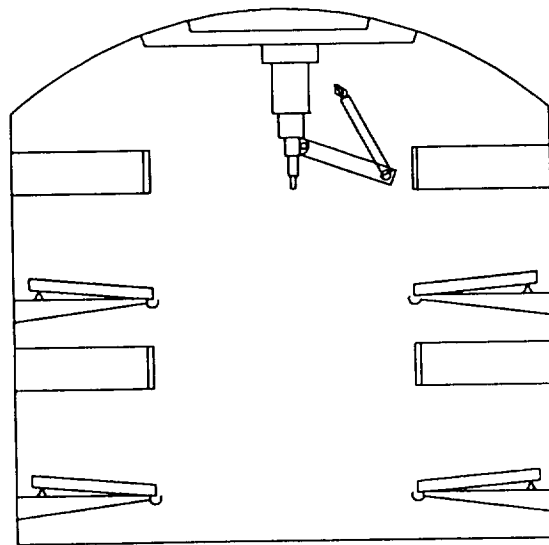

Figure 1.3.5.1.2 Supported Two Link Arm

may be prohibitively expensive. Whether such links can be employed without lubrication is also an important issue, as lubrication may affect the closed atmosphere of the chamber.

1.3.5.5 Hybrids

A screw shaft with a telescoping floor support may be used to deploy the two link arm (Figure 1.3.5.5.1). This would increase flexibility in the upper half of the chamber through vertical translation of the two link arm. The shaft would fold against the ceiling when stowed (Figure 1.3.5.5.2).

1.3.6 Overhead Beam Robot

1.3.6.1 Description

A horizontal beam spans the diameter of the chamber and is mounted on a track near the roof (Figure 1.3.6.1.1). Track following actuators rotate the beam around the chamber. A vertical screw shaft, which reaches the floor of the chamber, translates along the length of the overhead beam. A rigid arm, parallel to the overhead beam, is deployed vertically along the screw shaft. Deployment is accomplished by a combination of beam rotation, screw shaft translation and vertical translation of the arm. The system is stowed by rotating the overhead beam to the end of the shelves and moving the screw shaft to the wall.

1.3.6.2 Advantages

The short length of the rigid arm increases its stability by decreasing the moment arm of the payload. The horizontal beam adds to stability by increasing the lateral support of the system. The stowed robot is away from the center of the chamber and overhead. The lack of pinch points adds to the safety of the robot. As the robot employs only three degrees of freedom, control will be simple.

1.3.6.3 Disadvantages

Flexibility of the robot is limited in the upper reaches of the chamber. The installation of the system will require extensive modifications to the chamber. The length of the horizontal beam will make angular deployment slow. The lack of redundancies will decrease the safety.

1.3.6.4 Feasibility

The installation of the track may prove impractical due to conflict with existing chamber hardware. The custom fabrication of the track may be too expensive to be practical.

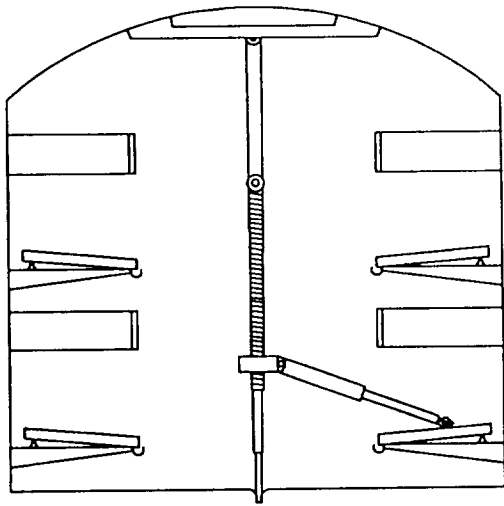

Figure 1.3.5.5.1 Supported Two Link Arm Hybrid

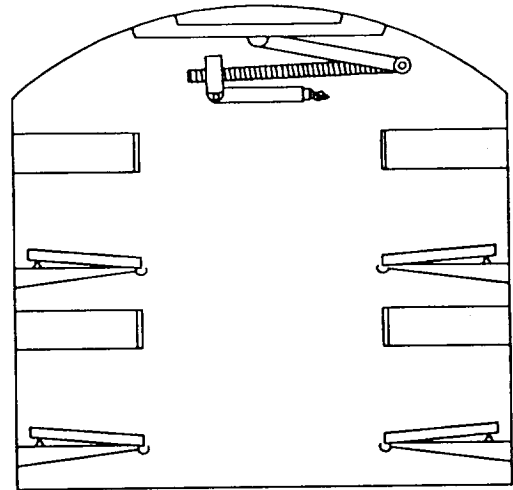

Figure 1.3.5.5.2 Supported Two link Arm Hybrid Stowed

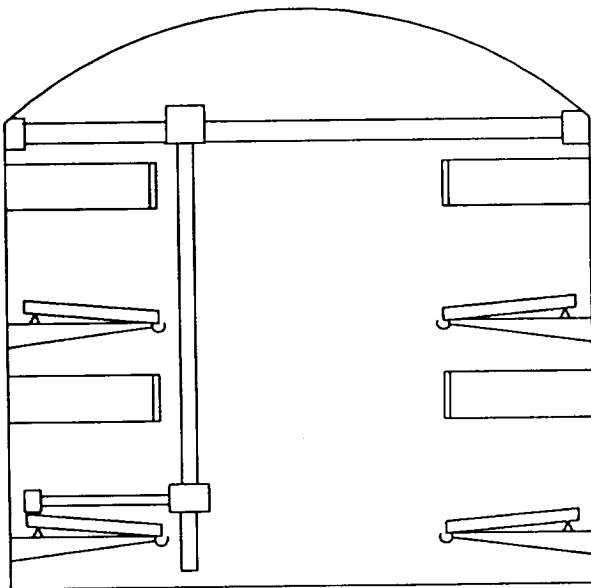

Figure 1.3.6.1.1 Overhead Robot Side View

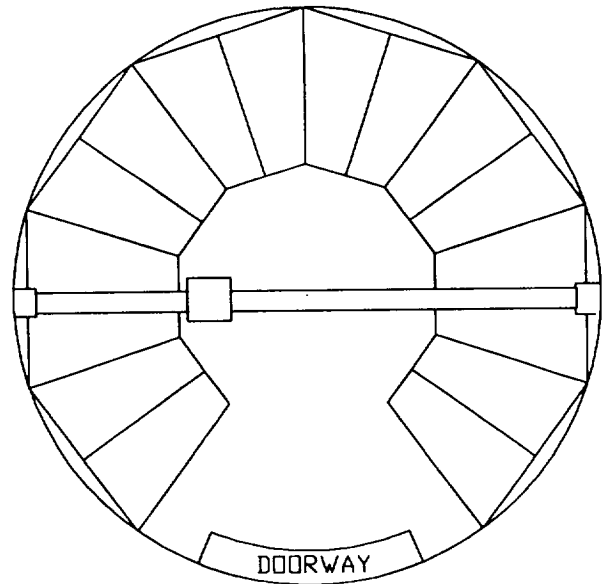

Figure 1.3.6.1.1 Overhead Robot Top View

Chapter 2.0 FINAL DESIGN

2.1 INTRODUCTION

The final design of the robot incorporates aspects of several of the early designs. The deployment of the robot is accomplished by an overhead track which allows movement of the robot from the wall to the center of the chamber. When locked in place at the center of the chamber, the robot will be in the deployed mode. Vertical movement in the chamber is accomplished by means of a ball bearing shaft. Angular deployment of a telescoping arm is accomplished by a rotating turntable bearing. By means of this system, a payload may be placed at any point within the requirements of the project. The absolute positioning obtained by locking the vertical shaft in place will simplify control greatly.

The robot design group has been divided into three sub-groups, each with a sub-system of the robot to design. This report will deal with the design of the track system and the base assembly. It was determined that the most effective operating position of the base would be at the center point of the ceiling. For greatest stowability, the robot must stow along the wall of the chamber. The purpose of the track is to allow the movement of the base assembly between the ceiling and wall. This movement should not require more than two people. The base assembly should be capable of smoothly moving the robot along the track, and fixing the robot in place when stowed and when deployed.

2.2 SUB-SYSTEM REQUIREMENTS

The following are the design requirements for the track and base assembly sub-system for the CELSS robot:

1. While not in use, the robot shall be stowed to avoid unduly affecting experiments and to allow personnel access to the chamber.
2. While not in transit, the sub-system should be locked in place to prevent movement.
3. Deployment and stowing of the robot will not require more than two people.
4. The sub-system shall be capable of supporting the robot with a 15 kg payload at the end effector.
5. Installation shall minimize modification to the CELSS chamber.
6. The robot shall function through all possible CELSS environment conditions.
7. The robot shall not alter the chamber environment.

8. The robot shall conform to design standards for KSC and military projects.
9. SI measurements will be used in design.

2.3 SUB-SYSTEM DESCRIPTION

2.3.1 Hardware Description

2.3.1.1 Rail Assembly

A vendor search determined that a curved track was not feasible. The track will be mounted in an inverted horizontal fashion to allow movement of the robot from the center of the chamber to the wall. The rail assembly is a LinTech 1.98 m rail system⁷. The system consists of two circular 1.59 cm diameter rails mounted to a flat 11.75 cm wide support (Figure 2.3.1.1.1). This system will be suspended in an inverted position from the ceiling. The track support is made of black anodized aluminum with steel rods for the rails. As recommended by the manufacturer, the rails will be chrome plated to avoid corrosion in the chamber environment.

2.3.1.2 Carriage Assembly

A LinTech #46 carriage assembly will be used to move the robot from the stowed to the deployed positions. This assembly mounts a flat 17.15 cm X 30.48 cm plate on four pillow blocks for linear translation along the rail (Figure 2.3.1.2.1). Pillow blocks have been chosen which do not require lubrication. This carriage is rated by the manufacturer at a maximum load capacity of 2850 N in an inverted position. This should be more than sufficient to support the 60 kg mass of the robot and will also provide a factor of safety of 2 over yield.

2.3.1.3 Mounting

To provide support for the track, a C5 X 9 channel will be bolted to the track along its length at existing fastener holes. The existing holes are located in pairs every 27.94 cm along the length of the track. S3 X 7.5 beam supports will be used to mount the channel to the roof. The ends of the beams will be cut at a 45 degree angle. Flat plates, 7.67 cm X 6.35 cm and .64 cm thick, will be welded to the ends of the I-beams. A pair of I-beams will then be bolted, with two 1cm bolts on each side, to the sides of the channel through their end-plates at four points along the channel. These supports number 1-4 from the wall (Figure 2.3.1.3.1-Figure 2.3.1.3.4). The other ends of the I-beams will be bolted, with four bolts on each beam, to the roof of the chamber. Silicone sealant will be used ensure an airtight seal around the bolts through the roof. Four pairs of supports will be mounted to the channel along its length (Figure 2.3.1.3.5). The use of four support pairs will ensure that the rail does not bend beyond 0.00054 m. This gives a factor of

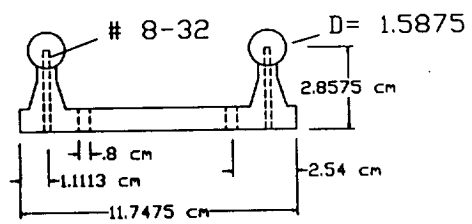
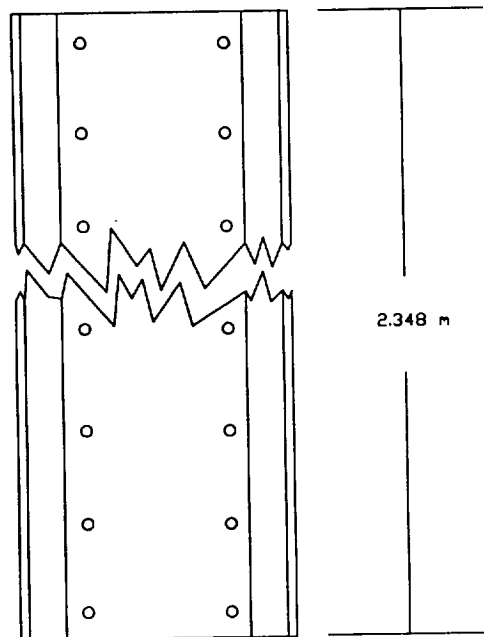
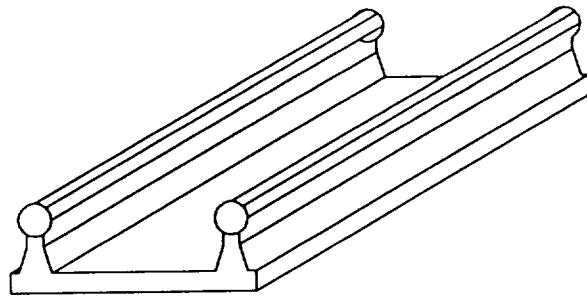

Figure 2.3.1.1.1 Track Configuration

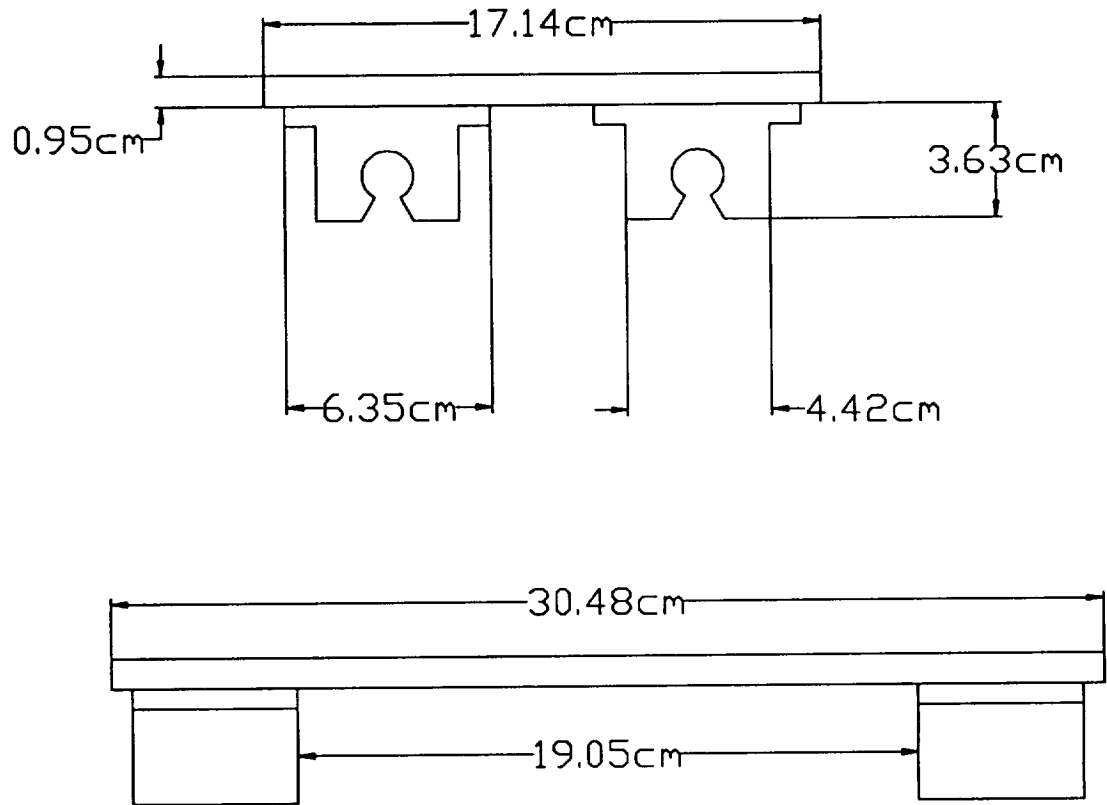

Figure 2.3.1.2.1 Carriage Assembly

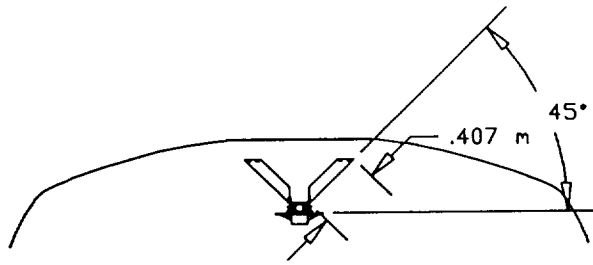

Figure 2.3.1.3.1 Support #1

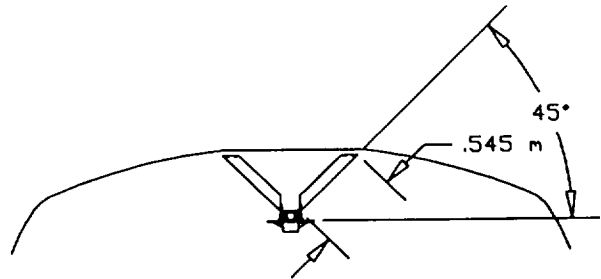

Figure 2.3.1.3.2 Support #2

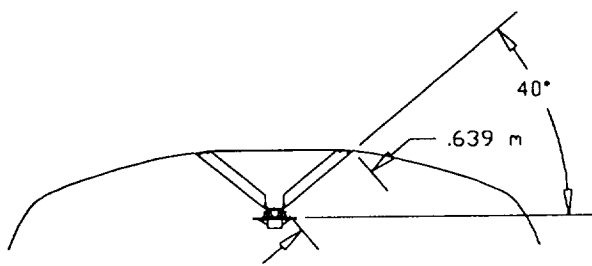

Figure 2.3.1.3.3 Support #3

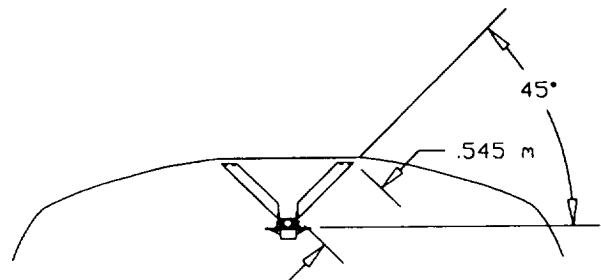

Figure 2.3.1.3.4 Support #4

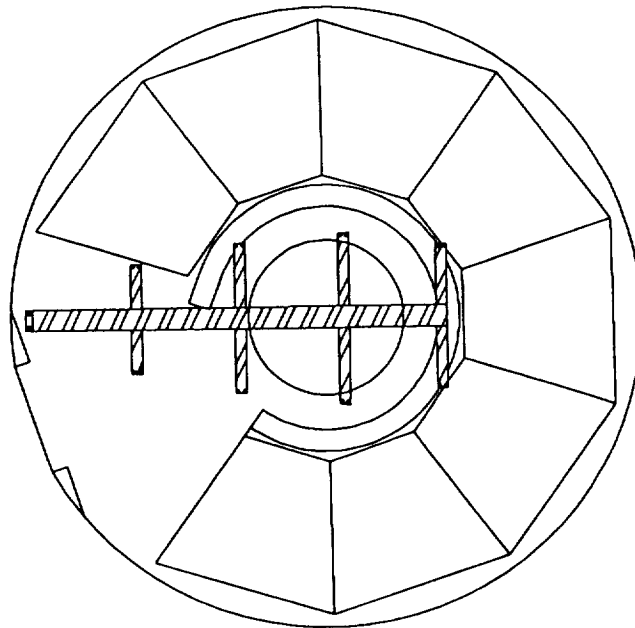
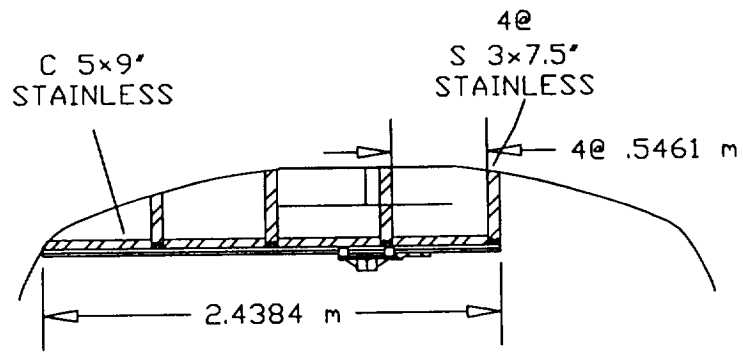

Figure 2.3.1.3.5 Rail Sub-System

safety of two over the maximum allowable deflection, as specified by the manufacturer of Simplicity bearings.

2.3.1.4 Bearings

Simplicity bearings have been chosen for the pillow blocks⁸. These bearings do not require lubrication or maintenance, even in harsh environments. The Frelon liner creates low wear and high strength, and will not peel, extrude, or separate. The load advantage is four to eight times greater than linear ball bearings. The temperature ranges and humidity levels of the chamber will not effect performance. The liner is chemically inert and resists most chemicals. The thick liner dampens shock and absorbs vibration. The coefficient of friction is the same under static conditions as under dynamic conditions, eliminating sticking or slipping.

2.3.1.5 Positioning Mechanism

Positioning of the carriage in the deployed position will be maintained by a locking mechanism. This mechanism consists of a probe (Figure 2.3.1.5.1) which is notched for the reception of a pin and a base assembly (Figure 2.3.1.5.2) that contains a spring loaded pin. The probe will be attached to the bottom of the interface plate with two 1 cm bolts. The bolts also serve to secure the interface plate to the carriage. When the robot is deployed, the probe on the carriage will insert into the base assembly which is itself attached to the rail base. A spring loaded plunger inserts into the notch on the probe and secures the carriage. A spring installed around the probe will absorb any impact generated when the robot is deployed. To release the carriage when stowing the robot, the plunger will be pulled manually from the probe notch through a cable release. The base assembly is attached to the positioning mechanism (Figure 2.3.1.5.3) so the deployed position of the carriage is adjustable along the length of track.

2.3.1.6 Stowed End Stop

For positioning when stowed, a simple stop block will be attached to the track base which will stop the carriage. This block will prevent movement of the carriage beyond the desired stowing position.

2.3.1.7 Braking Mechanism

The frictional coefficient (static and dynamic) of the Simplicity bearings is .24. This will act as a braking mechanism for the carriage. The braking force from the bearings is equal to the normal force of the weight of the robot and carriage multiplied by the frictional coefficient. This force has been calculated (Equation 2.3.1.7.1) for an assumed assembly mass of 120 kg to be 281 N. This force will act as a braking mechanism and prevent excessive carriage speed during deployment.

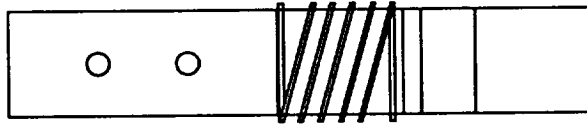
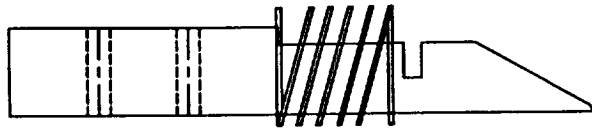

Figure 2.3.1.5.1 Probe

Cutaway of Locking Mechanism

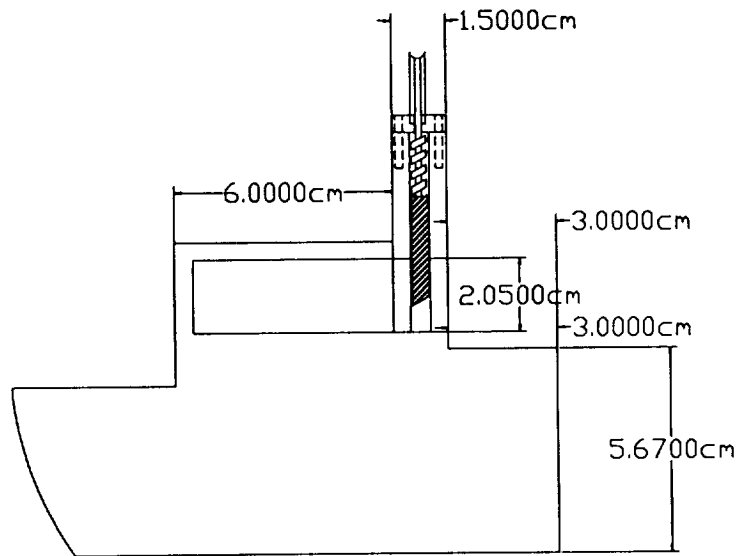
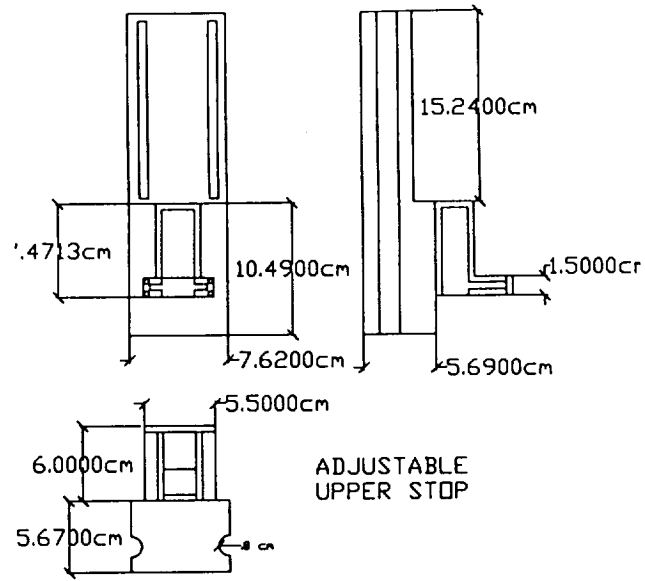

Figure 1.3.1.5.2 Locking Mechanism



INVERTED VIEW OF ADJUSTABLE UPPER STOP
IN SECTION OF TWIN RAIL

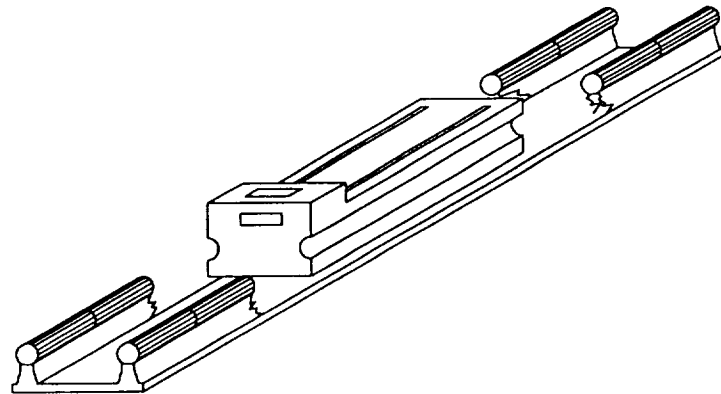

Figure 2.3.1.5.3 Adjustable End Stopper

Equation 2.3.1.7.1

$$F_B = (\mu_k) * (W)$$

2.3.1.8 Ball Screw Interface Plate

A 17.15 X 30.48 cm aluminum alloy plate with a hollow aluminum alloy cylinder will be used to mount the ball screw to the carriage (Figure 2.3.1.8.1). The cylinder will be hollowed to accept the 32 mm shaft end. The plate will be fastened to the carriage at four bolt holes located at the corners of the plate. Two stainless steel pins, each 1.27 cm in diameter, will be used to fasten the shaft to the interface plate. The pins will be inserted through the hollow cylinder and shaft at right angles to each other for stability. Cotter pins will be used to hold the fasteners in place. This will allow easy removal of the shaft for maintenance.

Aluminum alloy 6061-T6 will be used for fabrication of the interface plate. This alloy is used in heavy duty structures where corrosion resistance is needed. The alloy displays excellent corrosion resistance in all natural atmospheric environments and many artificial ones⁹. The aluminum will be black anodized to further protect against corrosion.

To provide lateral flexibility of the deployment position, the four bolt holes on the interface plate will be slotted to 2.5 cm in length. This will permit the bolts to be fastened at any point along the slot length, permitting exact fine tuning of the robot position in the direction perpendicular to the rail.

2.3.2 Installation

Following is the procedure for installation of the track system:

1. The C-channel is bolted to the track base.
2. The I-beam supports are bolted to the channel.
3. The interface plate is bolted to the carriage.
4. The carriage is mounted to the rail.
5. The end stoppers are attached to the rail base.
6. The locations of the bolt holes through the chamber roof are determined by positioning the rail assembly as specified.
7. The bolt holes are drilled through the chamber roof.

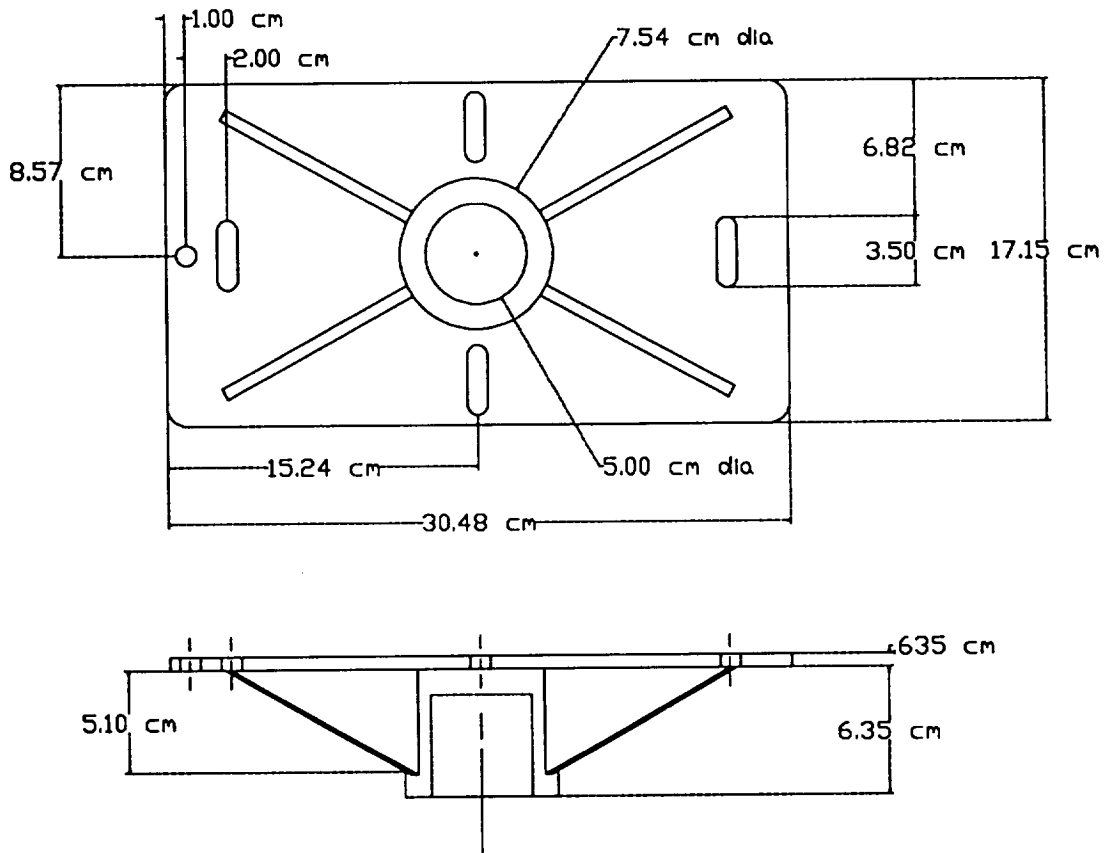

Figure 2.3.1.8.1 Interface Plate

8. The I-beam supports are bolted to the chamber roof.
9. The bolt holes throughout the chamber roof are sealed with silicone sealant.

2.3.3 Deployment

After installation, the following procedure is used to deploy the robot:

1. The vertical shaft is pushed from the stowed position to the center of the chamber until the carriage contacts the adjustable locking mechanism.
2. The support jack on the bottom of the vertical shaft is deployed.

To stow, this procedure is followed in reverse order.

2.3.4 Kinematic Analysis

When deployed, the robot must be capable of reaching points from 15.24 cm above the chamber floor to 25.4 cm above the top light rack. A horizontal track is oriented near the roof to allow stowage of the robot in the area between the end of the shelves and the door. The stowed position of the robot will be at chamber wall. Fixed stops at the end of the track prevents the robot from leaving the track. Deployment and stowing of the robot is accomplished by manually moving the robot along the track. An adjustable locking mechanism allows fine tuning of the deployed position.

2.3.5 Stress Analysis

Principle stresses during movement of the robot occur in the track system. To increase the stability of the track, a C-channel is bolted to the track. This channel increases the rigidity of the track and helps avoid deflection of the rods. To further decrease the deflection of the rods, additional supports are added along the length of the track. The distance between these supports is based upon the maximum allowable deflection of the track specified by the manufacturer of the Simplicity bearings, this deflection value is .00108 m. With a factor of safety of 2, the maximum allowable deflection desired becomes .00054 m. By using Equation 2.3.5.1, a length of .667 m between supports can be interpolated¹⁰. This equation assumes deflection due to robot weight and deflection due to track and channel weight are cumulative. The weight of the track and channel per meter is 234.3 N/m. The weight of the robot is 1177 N.

Equation 2.3.5.1

$$V_{\max} = \frac{5q_0L^4}{384EI} + \frac{WL^4}{48EI}$$

q_0 = Weight per meter
 L = Length between supports
 W = Weight of robot
 E = Modulus of Elasticity
 I = Moment of Inertia

Principle stress of the robot during operation occurs due to a moment arm created by the weight of robot arm and payload about the shaft. The supports are angled to account for the moment created when the robot is perpendicular to the track. The maximum value of this moment occurs when the arm is extended to its range of 1.8 m with a load of 15 kg at the end effector, and the weight of the arm at the center of gravity. This moment, taken around point A at the base of the ball screw, must be countered at the top of the ball screw, 3 m, by the a force of 151 N can be calculated. This force acts in the horizontal direction, while the 686.7 N weight of the robot acts in the vertical direction. These values yield a force vector at 77 degrees to the horizontal axis. An angle of 45 degrees is used for the supports to account for future modification of the robot for greater loads.

Stress calculations were preformed to determine proper sizing of fasteners¹¹. For horizontally oriented fasteners, stress area was calculated as the diameter of the fastener multiplied by the depth of penetration. For vertical fasteners, the area was calculated using Equation 2.3.5.2. The force acting on the fasteners was determined, and a stress was calculated by Equation 2.3.5.3. This stress was compared against a allowable stress to determine feasibility. All fasteners will be stainless steel (Alloy 304). The allowable tensile stress for stainless steel is 579 MPa. A common fastener size of 1 cm will be used to minimize the number of tools needed for installation. The fasteners used to mount the supports to the ceiling and to mount the supports to the channel will be fine thread. All fasteners used in aluminum will be coarse thread and use insulating vinyl tape to protect against galvanic corrosion.

Equation 2.3.5.2

$$A_s = 5.067 \left(D - \frac{.9743}{n} \right)^3$$

A_s = Stress Area
 D = Diameter of bolt
 n = Threads per inch

Equation 2.3.5.3

$$\sigma = \frac{F}{A_s}$$

F= Force on fastener

A_s= Stress area

σ= stress

The cylinder on the interface plate is fillet welded on its entire perimeter to the base plate. The channel support beams are welded to a fastener plate. The welds are required to be at least 0.64 cm in width. For the parallel fillet weld used, the maximum allowable shear stress and normal stress are 796 kPa and 873 kPa, respectively. The equations used for the calculations are given by Equation 2.3.5.6 and Equation 2.3.5.7.

Equation 2.3.5.6

$$\tau = \frac{F}{A}$$

τ= shear stress

F = shear force

A = area

Equation 2.3.5.7

$$\sigma = \frac{MC}{I_u}$$

σ= normal stress

M = moment

C = Distance from axis of rotation

I_u = unit second moment of area

2.3.6 Vibration

The type of forcing function and imbalances occurring in the system are to be determined. This fact does not allow numeric analysis to be completed, instead some fundamental methods of reducing vibrations in our design are presented. To minimize residual vibrations the rail carriage is mounted on Simplicity Bearings. These solid polymer bearings use a 0.05 cm liner to dampen shock load and absorb vibration. Simplicity Bearings provide more effective surface area than do ball bearings. This additional area provides increased vibration damping by better distributing the shock load. The bearings do not stick or slip. This quality eliminates binding and vibration of the carriage.

A viscoelastic coating is applied to the carriage plate and to the shaft interface plate to eliminate the transmission of vibrations.¹⁴ A Frelon liner is used in the cup of the interface plate to absorb shock transmitted from the screw shaft to the carriage. All fasteners incorporate slotted and castellated nuts to avoid vibration loosening.

2.3.7 Maintenance

Cotter pins to hold the shaft fasteners in place allow easy removal of the shaft for maintenance of the shaft and telescoping arm. The Simplicity Bearings are manufactured to require no lubrication or maintenance, even in harsh environments. The removal of the adjustable stopping block at the deployed end of the track allows removal and maintenance of the carriage and interface plate. The track and carriage assembly are environmentally resistant and do not require maintenance or inspection.

2.3.8 Safety

Due to the large friction force generated by the bearings, the carriage stops itself quickly. This inherent braking feature prevents accidental translation of the carriage and therefore eliminates damage to the robot during deployment. Risk of injury to personnel while deploying the robot is minimized.

As the entire rail and carriage system is located at the roof of the chamber, catastrophic failure of the mounting brackets poses a hazard to personnel below. Special attention must be paid to the construction and installation of the mounting brackets to avoid such a failure.

Other critical parts include the interface plate and the pins which secure the ball screw. Stress analyses of these components have confirmed their theoretical strength, yet attention must be paid to their construction and maintenance. Periodic inspection of welds and fasteners are needed to spot corrosion or deterioration which may lead to failure.

2.4 SUMMARY

The track and carriage assembly sub-system provides a means for moving the robot apparatus from the stow position at the wall to the deployed position at the center of the ceiling. The movement of the robot requires no more than two people, and the carriage assembly locks in place while not in transit.

A horizontal track provides adequate stowability and ease of deployment. An inverted carriage translates from the deployed position at the center of the chamber to the stowed position near the chamber wall. Attached to the carriage is an interface plate with a hollow cylinder which receives the ball screw. The ball screw is secured to the cylinder with two removable stainless steel pins.

A locking device secures the carriage in the deployed or operational position on the track. The device is adjustable both along the track and laterally. This allows for fine tuning of the operational position of the robot so that the ball screw will be aligned with the location of the floor jack receptacle on the chamber floor. During deployment, the friction force generated by the Simplicity Bearings acts as a braking mechanism and will control the speed of the carriage.

The locking device is released by pulling a ring attached to a short release cable. A hook on an extension handle is employed to perform the release operation, as the hook may be stored outside of the chamber while the robot is in operation.

Chapter 3.0 OBSERVATIONS AND RECOMMENDATIONS

The dimensions used for design of the track supports are based on rough field measurements. The measurements made on site did correspond to the data given on the plans obtained from NASA. Exact measurements of the chamber confirmed positioning of the beam supports for the track assembly.

The PVC pipe, attached along the inside shelf diameter, need to be modified to allow for maximum stowability. This pipe appears to be a standard length pipe fitted to the shelf and thus shortening should not be a problem.

Chapter 4.0 ACKNOWLEDGEMENTS

Our sincere appreciation to Gabor Tamasi who has provided invaluable advice and counsel into the design of the robotic systems and has guided the robot's design throughout. Bill Johnson of the CELSS project has generously taken time out of his schedule to conduct tours of the chamber and give his input towards the outcome of the design effort. For technical information and advice on bearing selection and lubrication, we are indebted to Dr. Stephen Rice who provided insight in this area. Val Gomez of Lintech, Inc. provided technical assistance which led us to select Lintech products for our subsystem.

SECTION II

VERTICAL SHAFT SUB-SYSTEM

CONCEPTUAL DESIGN

- * TRACK DRIVEN ROBOT
- * POLE MOUNTED ROBOT
- * CABLE ROBOT
- * LEG-MOUNTED ROBOT
- * LINK-MOUNTED ROBOT
- * TELESCOPING LINK-MOUNTED ROBOT
- * DUAL ARM WALL MOUNTED ROBOT

FINAL DESIGN

- * BALL SCREW / BALL SPLINE SHAFT
- * CENTRAL MOUNTING STRUCTURE
- * BALL SCREW NUT
- * BALL SPLINE NUT
- * TURNTABLE BEARING
- * LOWER SUPPORT BOOT
- * CABLE REEL
- * CRITICAL ANALYSIS
- * OBSERVATION AND RECOMMENDATIONS

Chapter 5.0 INTRODUCTION

The CELSS chamber is used to perform research on hydroponic plant growth in a closed environment. The CELSS chamber research is performed over the entire plant life cycle and can be used to enhance our understanding of life science manipulation in closed test beds and also provide a baseline for space applications (i.e. space station modules and lunar based space labs). Current and future operations within the CELSS chamber restrict human entrance to avoid contamination, and provide a perfect opportunity for the implementation of an automated system that will be capable of performing expanded tasks.

Phase I of the proposed robot design will be used to measure environmental parameters as follows: 1) temperature, 2) light level, 3) humidity, 4) air flow, and 5) CO₂. Phase II of this project is to use this robot to tend the plants in the CELSS chamber. Plant tending includes planting, removal and harvesting of crops, adjusting and checking nutrient stream flow. The proposed design must be able to reach all areas within the working envelope of the CELSS chamber with sensor array and gripper, support a maximum load of 15 kilograms at the end effector, and be stowable within the chamber to allow for normal operations to continue (Appendix B, Specifications). Additionally the system design configuration should minimize stowed volume and chamber facility modifications.

The ball screw / ball spline subsystem enables the robot arm to translate in the vertical direction and rotate 360° about the vertical axis. The telescoping robot arm is mounted on the turntable bearing which is located on the top section of the CMS. The telescoping arm can manipulate the end effector to within 0.254 meter above the floor of the chamber and 0.15 meter above the upper lamps to access a tool changer.

5.1 OVERVIEW OF DESIGN

This design consists of a telescoping robot arm that slides vertically on a shaft which is positioned in the center of the CELSS chamber (Figure 5.1.1). The telescoping robot arm consists of a series of links which can be fully extended to a length equal to the radius of the working envelope of the CELSS chamber¹⁵. The vertical motion of the robot arm is achieved through the use of a combination ball screw / ball spline actuator system. The robot arm rotates cylindrically about the vertical axis through the use of a turntable bearing attached to a central mounting structure which is fitted to the actuator shaft. The shaft is installed on an overhead rail system which allows the entire structure to be stowed and deployed within the CELSS chamber. The overhead rail system is located above the chamber's upper lamps and extends to the center of the CELSS chamber. The mounting interface of the actuator shaft and rail system allows the entire actuator shaft to be detached and removed from the CELSS chamber. When the actuator shaft is deployed it is held fixed at the bottom of the chamber by placing a square knob on the bottom of the shaft into a recessed square fitting in the bottom of the chamber floor. A support boot ensures the rigidity of the shaft.

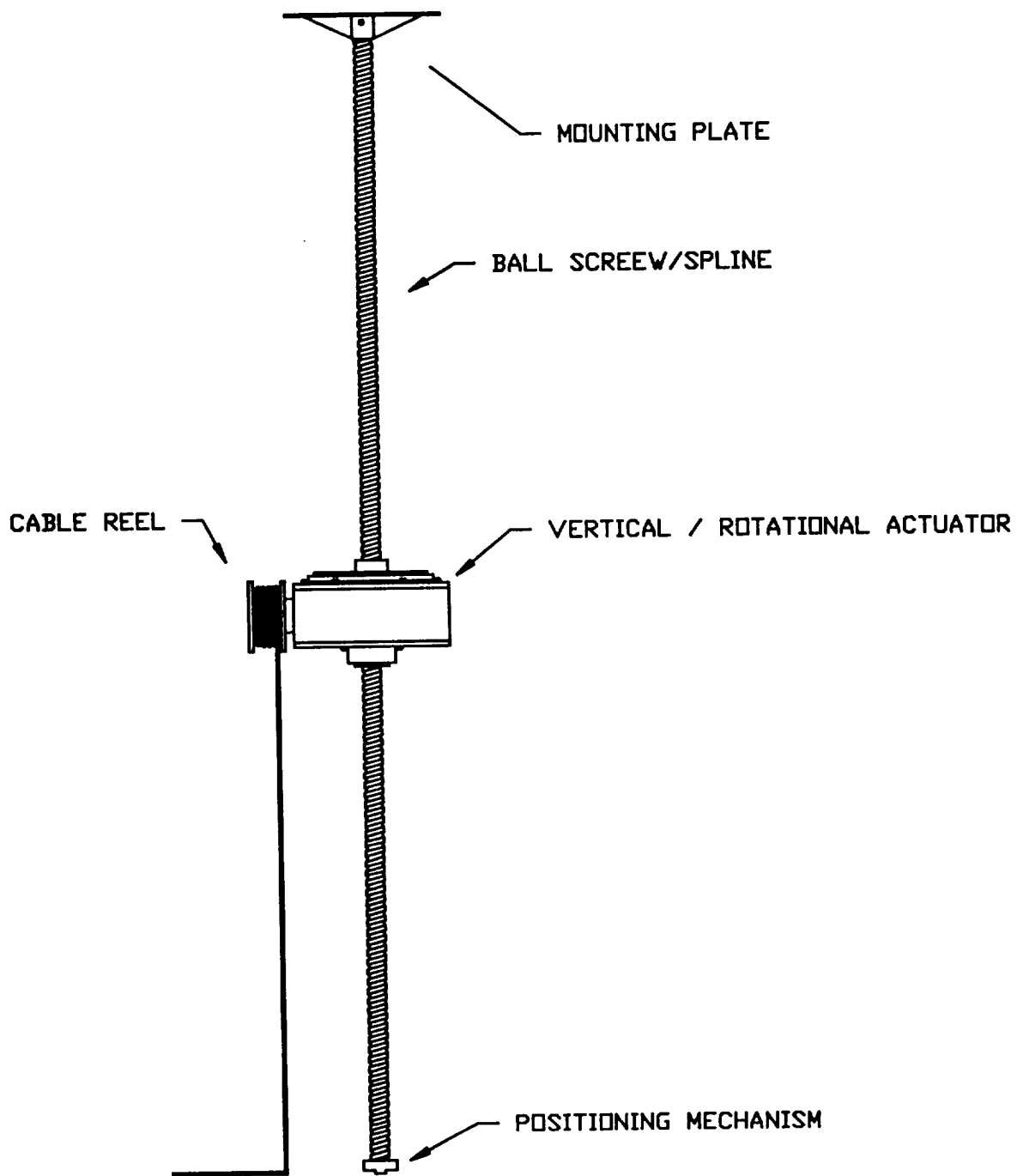

Figure 5.1.1 Vertical and Rotational Shaft Actuator Subsystem

Chapter 6.0 POSSIBLE DESIGN SOLUTIONS

The selection of the robotics system and specifically the manipulator arm was based on the intended applications mentioned in Chapter 5. Consideration was placed on repeatability, maintenance, safety, environmental conditions, availability of sensory information for the controller, number of major components, accessibility and other issues¹⁶. The term repeatability¹⁷ refers to the measure of consistency of the end effector returning to a specified point when placed in a repetitive motion.

The following will present the advantages, disadvantages and the feasibility for each robot design concept. There are figures depicting each design in its deployed operational and stowed positions. We have presented several conceptual ideas with their advantages and disadvantages based on the design specifications given. No conclusions are given in this section.

6.1 TRACK DRIVEN ROBOT

This conceptual design consists of a fully self-contained configuration that uses a combination of telescoping and an articulated arm³ (Figure 6.1.1). This design has a wide range of mobility which allows it to be easily positioned within the CELSS chamber to perform necessary tasks. When deployed, this design will lock into position by lowering two support arms which will provide additional stability while performing necessary tasks within the CELSS chamber.

6.1.1 Feasibility

This design may not be feasible because it is potentially unstable. The instability is a result of the fact that it is not permanently affixed to the CELSS chamber. The length of the components necessary in the arm to reach all areas of the working envelope could also be a source of instability. The weight necessary to ensure stability of the base of this robot could apply undue stress to the floor of the CELSS chamber. This design will also require complicated sensory and control systems to ensure no damage is done to the CELSS chamber.

6.1.2 Advantages

This design requires minimal, if any, modification to the CELSS chamber. The robot does not require extensive mounting installations within the CELSS chamber. Since the robot is a free and portable unit, maintenance routines can be performed both inside and out of the CELSS chamber. This allows maintenance to be performed in a safe and comfortable environment while normal CELSS chamber operations continue. The robot may also be used for other applications since it is not permanently mounted within the CELSS chamber (Figure 6.1.2.1). Since chamber modifications are minimal, few

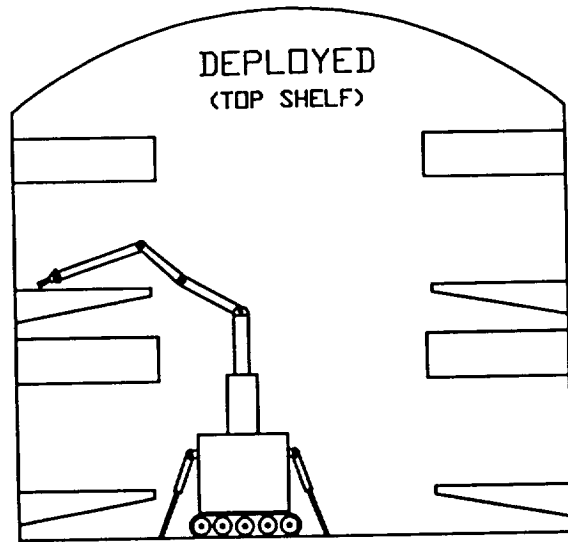

Figure 6.1.1 Deployed Track Robot

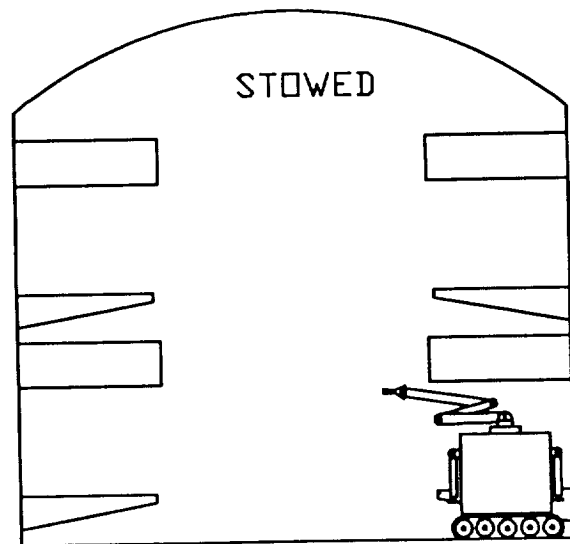

Figure 6.1.2.1 Stowed Track Robot

interruptions of normal CELSS operations result. The robot requires minimal storing space with its telescoping design.

6.1.3 Disadvantages

Due to the unmounted configuration of the robot requires elaborate sensory and control device systems. Also, the free standing nature of the robot requires additional actuators for the support arms used in the deployed stationary position. This free unit design requires an independent power source which involves heavy battery packs. These battery backs require periodic recharging.

6.2 POLE MOUNTED ROBOT

This design concept consists of an articulated robot arm that slides vertically on a pole which is positioned in the center of the CELSS chamber (Figure 6.2.1). The vertical motion of the robot arm is facilitated by rollers within the collar attached to the pole. The robot senses its position by bar codes placed on the pole. The pole is installed on an overhead gantry robot which is a special type of cartesian robot manipulator. This configuration moves the robot arm in the horizontal plane of the CELSS chamber. The mounting system is located above the upper lamps in the CELSS chamber (Figure 6.2.2). This horizontal motion allows the robot arm to be positioned closer to the plant trays. The robot arm rotates in cylindrical motion around the pole. The arm consists of two short links which can be extended. A combination of the extension and rotation of the arm allows the robot to reach all necessary areas within the working envelope of the CELSS chamber. The robot is stowed out of the way in the space just left of the door (Figure 6.2.3).

6.2.1 Feasibility

The pole robot is an accurate and stable system configuration. However its bulky configuration and stow mechanism make it more complex. The number of components required for this robot increase the cost of construction.

6.2.2 Advantages

The overhead gantry system uses cartesian motion which is simple and requires fewer control systems. The pole is positioned close to the plant tray being tended thus the a shorter robot arm with less links is required. This will increase stability of the robot and reduce the strength requirements of materials used in construction. Maintenance is preformed easily since the robot can be positioned at a comfortable height in the center of the CELSS chamber. The electrical cabling is safely stored within the vertical pole.

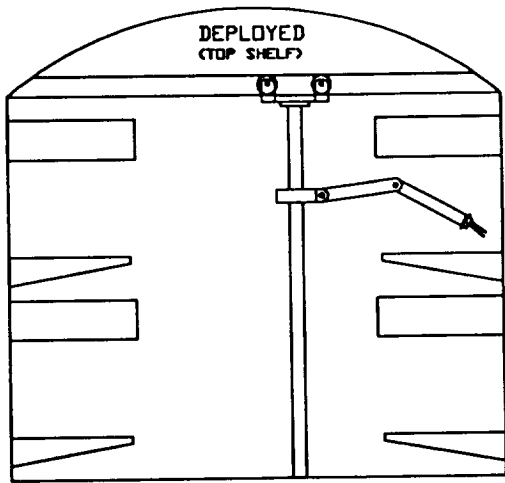

Figure 6.2.1 Deployed Pole Robot

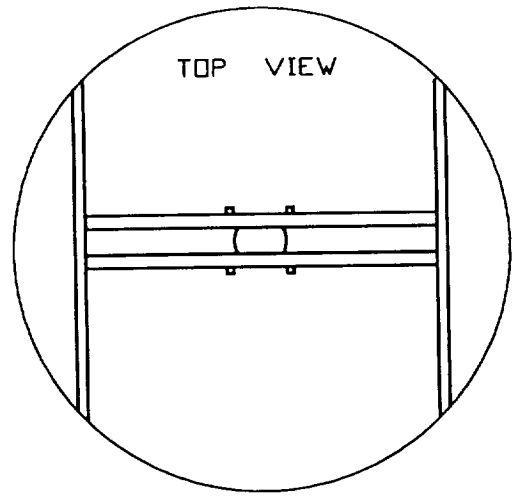

Figure 6.2.2 Overhead Gantry System

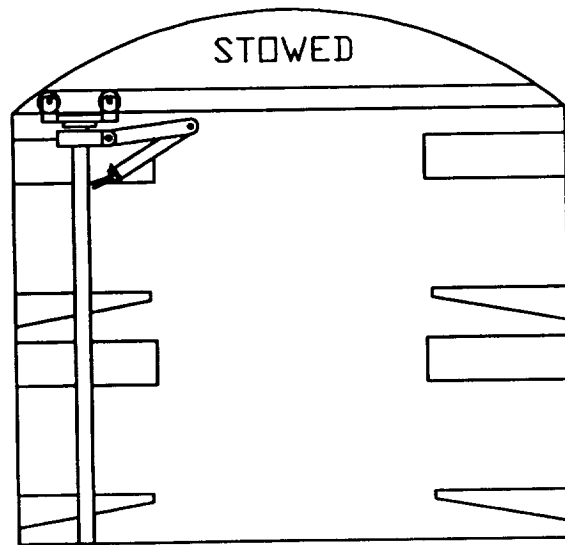

Figure 6.2.3 Deployed Pole Robot

6.2.3 Disadvantages

The cartesian mounting system is large and requires some chamber modifications to the roof area. The roof mounting requires extra motors and safety sensors. Extra safety measures are required for personnel while the pole robot is in operation.

6.3 CABLE ROBOT

This design consists of an articulated robot suspended from the ceiling of the CELSS chamber via steel reinforced cables. The system is manually deployed by attaching a cable to a floor mounting (Figure 6.3.1). The robot readies itself for operation once activated by tightening the cables to a set torque requirement. The vertical motion of the robot is achieved through a system of motor driven pulleys located within the circular base of the system. The articulated robot arm is mounted to a collar base capable of rotating 360 degrees thus enabling the arm to reach all of the plant trays. In order to stow the cable robot, the cables are relaxed, the center support cable is disconnected and the stow mode switch is activated. The robot reels in the cables and positions itself in the upper portion of the CELSS chamber .

6.3.1 Feasibility

This conceptual design is relatively simple and efficient, however, its structural stability during motion may prove to be a problem due to vibrations from the internal pulley system. This design requires only minor chamber modifications, and the cost of its mounting system is minimal. Vertical motion control systems and maintainability are also simple and efficient due to the robots motor and pulley system.

6.3.2 Advantages

The simple cable and hook assembly of the robot system require only minor modifications to the CELSS chamber. Installation and cost of the robot mounting system are minimal, and its motor and pulley system is designed for efficient maintainability. In addition the arm is easily accessible for maintenance when in the deployed position.

6.3.3 Disadvantages

Structural stability of the robot during operation is questionable. The pulley systems used for vertical motion requires synchronization with the actuator control system resulting in a complicated feedback loop. The torsional stress required to support the robot may apply increased stress to the CELSS chamber, and the robot requires human interface to deploy and stow (Figure 6.3.3.1).

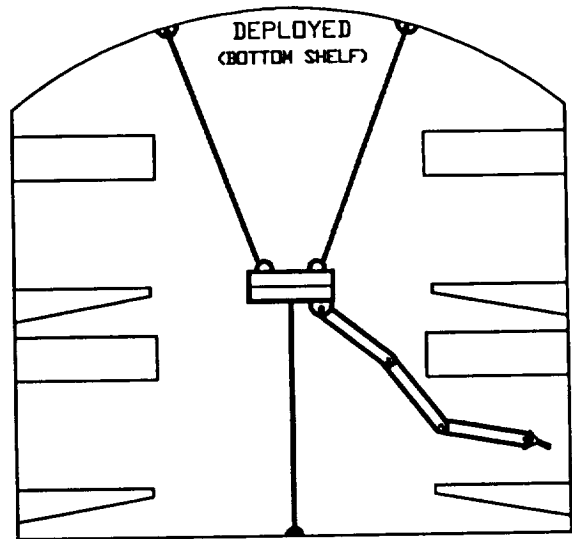

Figure 6.3.1 Deployed Cable Robot

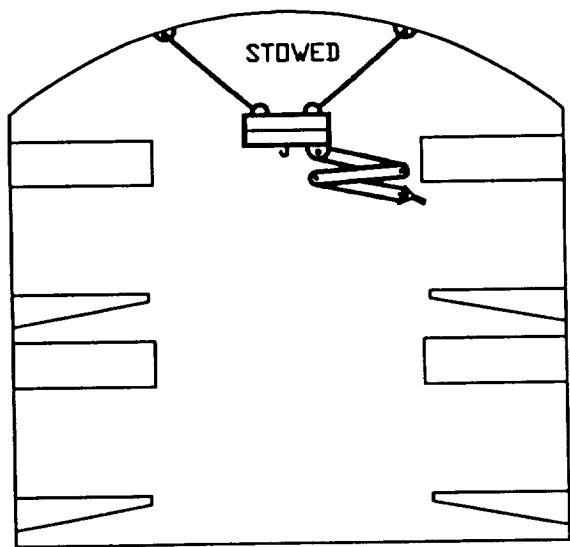

Figure 6.3.3.1 Stowed Cable Robot

6.4 LEG-MOUNTED ROBOT

The leg-mounted robot is an articulated robot arm suspended on a platform with telescoping tripod legs attached to mounting brackets in the floor. In order to deploy, the robot is pushed on rollers from its stowed position to the center of the chamber. On each tripod leg is a two position control lever. In one position it is on rollers and in the other the leg is locked down in the recessed floor attachments (Figure 6.4.1). The telescoping link legs allow the robot to tend to both levels of plant trays. The legs have three set positions. One for the tending of each level of plant trays and one for the stowing of the robot (Figure 6.4.2).

6.4.1 Feasibility

This concept is feasible and lower cost due to the manual deployment and stowing of the system. This design requires only minor chamber modifications, and the cost of its mounting system is minimal. There is some potential for instability due to the tripod design of the robot base.

6.4.2 Advantages

The Leg Mounted Robot requires only minor modifications to the CELSS chamber. The only required modifications will be three (3) recessed mounting brackets in the floor of the chamber for the tripod mounting system. Since there are no special mounting requirements or intricate system of robot mobility much time and expense are saved.

Due to the non-permanent mounting design of this robot, routine and unscheduled maintenance can be performed easily both inside and outside of the CELSS chamber. Also because of this mounting system the robot may be used for other applications with minor robot modifications. Also because of the un-mounted design the robot requires minimal storing space. The telescoping legs also reduce the storage space of the robot. The robot stores easily in the space to the right of the entrance to the chamber.

6.4.3 Disadvantages

One disadvantage to this design is that the robot is manually deployed and stowed. The telescoping legs used in stowing and deployment require complicated mechanisms for vertical movement. Due to the design of the legs, a redundant safety system has to be built for the legs and robot arm in the event of system failure.

6.5 LINK-MOUNTED ROBOT

The link-mounted robot is mounted on an overhead gantry similar to the Pole Mounted robot. This Cartesian system facilitates the horizontal motion of the robot. The robot has four (4) main links that are used for deploying/retracting the robot. These links are

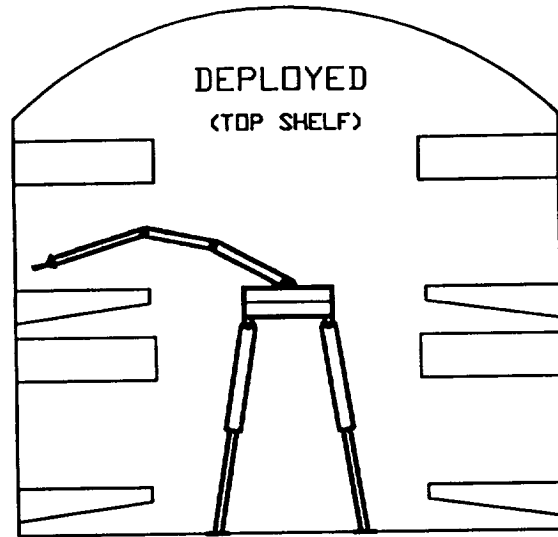

Figure 6.4.1 Deployed Leg-Mounted Robot

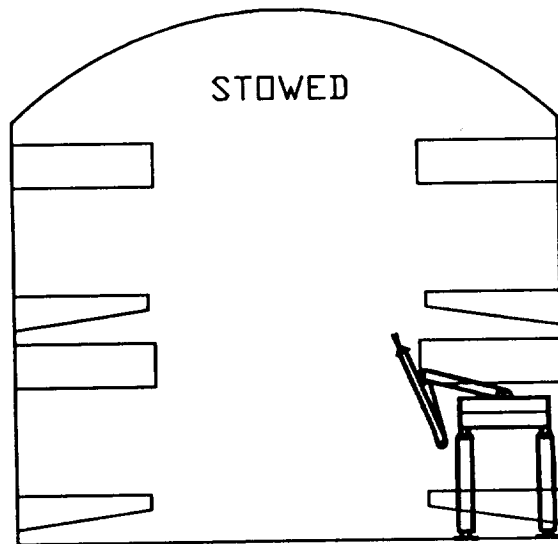

Figure 6.4.2 Stowed Leg-Mounted Robot

attached to the cross-bar of the cartesian mounting. When fully deployed the links will extend vertically downward enabling the robot to reach the lower plant trays in the CELSS chamber (Figure 6.5.1). For the robot to reach the upper trays in the chamber the four main links will retract into a horizontal position, level with the cross-bar to which they are attached. The robot arm itself consists of three (3) short links. When extended the arm can reach both the front and back of the plant trays. To facilitate the cylindrical motion of the robot arm the base of the robot will rotate in the horizontal plane. The robot arm, will stow from the retracted position by folding the links of the arm into a position that will not interfere with chamber operations (Figure 6.5.2).

6.5.1 Feasibility

The conceptual design allows the robot arm manipulator to reach the entire work envelope. The multiple supports ensure the load capacity and stability of the robot. Possible problems to overcome are interaction of redundant motors and structural components to ensure safety for this roof based design. Safety and maintenance issues can be met with a properly designed system.

6.5.2 Advantages

The automatic deployment/stowing of the robot reduces the human robot interaction. The link mounted design of the robot is a stable design. This design allows for heavy load capacity. The link design is also a reliable design in that the majority of the components used are mechanical. Cartesian movement in the ceiling mounting system allows for closer positioning to the plant trays.

6.5.3 Disadvantages

The design requires extensive chamber modifications. A tethered wire power cable will add design complexity for a safe design. Maintenance accessibility may be difficult because roof mounted components will require technicians to use ladders or elevated platforms. Another problem will be the installation of a permanent roof mounted cartesian positioning system. The roof mounted maintenance and components will be more complex due to the additional four (4) motion positioning links attached to the roof.

6.6 TELESCOPING LINK-MOUNTED ROBOT

This robot uses a cartesian configuration mounting structure with sliding links and an articulated configuration arm (Figures 6.6.1). The mounting structure mechanism will permit the robot to position itself at distances required to perform necessary tasks. The sliding link mechanism will permit the robot to stow closer to the ceiling, and also reach necessary areas within the CELSS chamber (Figure 6.6.2). The combination of articulated and telescoping arm gives the robot the flexibility required to insure proper positioning of the end effector during operations.

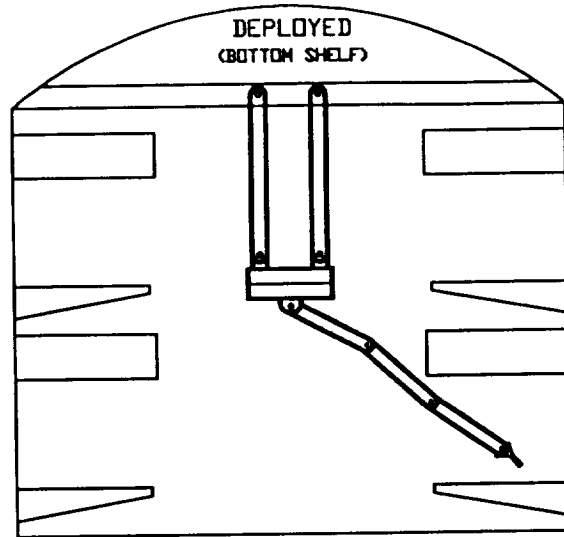

Figure 6.5.1 Deployed Link-Mounted Robot

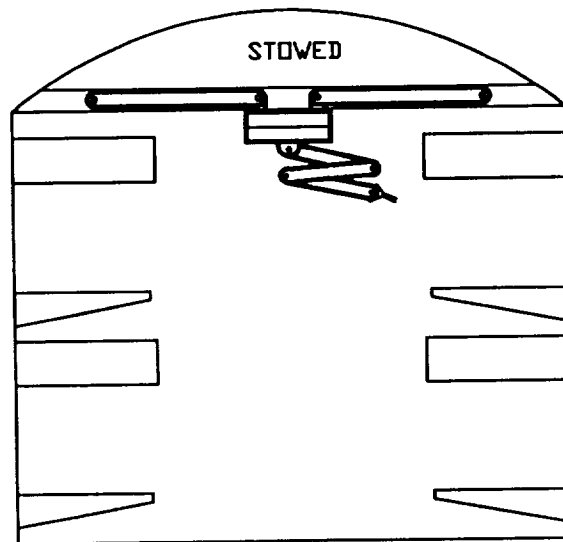

Figure 6.5.2 Stowed Link-Mounted Robot

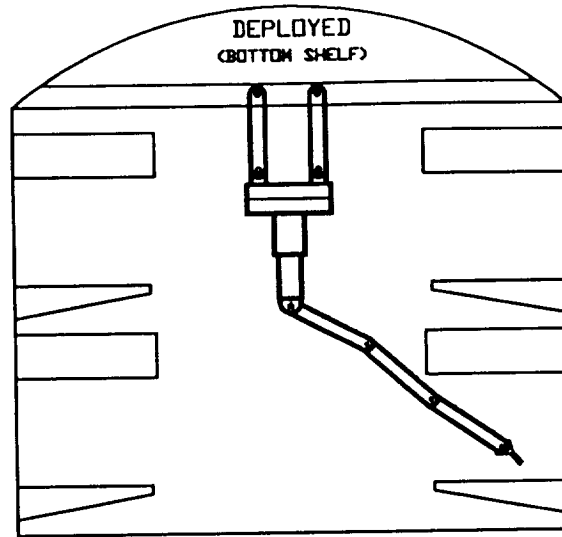

Figure 6.6.1 Deployed Telescoping Link-Mounted Robot

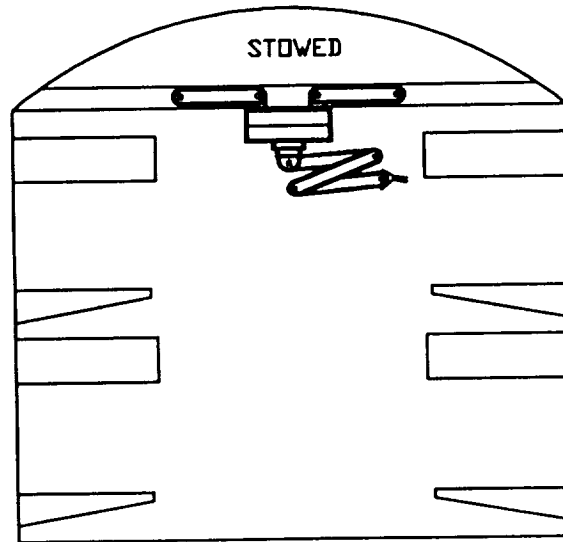

Figure 6.6.2 Stowed Telescoping Link-Mounted Robot

6.6.1 Feasibility

This conceptual design has the potential of performing all required tasks within the CELSS chamber. By combining an articulated arm with a telescoping base, this design has access to all regions within the CELSS working environment. It also has the advantage of minimal stowing area so it does not interfere with access to the CELSS chamber. A possible problem is encountered in maintainability and safety. Having a mounting structure attached to the ceiling might create some difficulty in maintenance routines due to the height of some of the components. Also, a ceiling mounted structure requires redundancy components to eliminate the possibility of injury to humans or the CELSS environment caused by falling parts in the case of structural failure.

6.6.2 Advantages

The robot is automatically deployed and stowed, and is stowed in an area that will not interfere with personnel operations when they need access to the chamber. Cartesian movement in the ceiling mounting system allows for closer positioning to the plant trays.

6.6.3 Disadvantages

Maintenance accessibility may be difficult because not all the components are accessible for maintenance routines and a ladder or platform is required to service the mounting structure. Extensive chamber modifications are required for installations to include attachment of a permanent mounting structure. Maintenance routines in general, are more complex due to the different type of motion mechanisms employed.

6.7 DUAL ARM WALL MOUNTED ROBOT

This design consists of two (2) separate two (2) link revolute (articulated) manipulator robots that are mounted on U-shape tracks extending around the CELSS chamber just below each of the lamp levels. The robot moves along the track via rubber rollers. Sensors determine the position of the robot by reading bar codes on the track. In the deployed position the robot can reach both the front and back of the plant tray positioned directly below the track (Figure 6.7.1). In the stowed position the robot links fold out of the way of normal operations.

6.7.1 Feasibility

This conceptual design requires extensive modification to install a track system. However once installed, the robot will perform all required tasks occupying minimum space. Two separate robot systems are required increasing the cost of the entire project. The repeatability of this design will be well within required specifications.

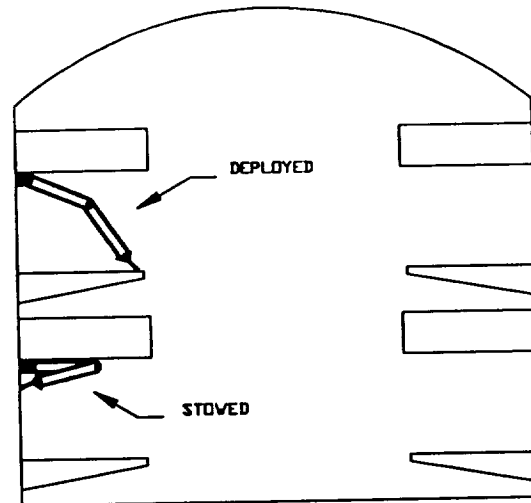

Figure 6.7.1 Dual Arm Wall-Mounted Robot

6.7.2 Advantages

The dual arm wall mounted design is simple compared to track driven, link and pole mounted hybrid. This is the only design which does not interfere with human attendants even when the robot is in operation. The robot stowing mechanism is simple compared to the previously presented design. The robot arm is shorter and thus easier to design within stability requirements. The robot is out of the way even while in operation. The robot is automatically deployed and stowed which reduces robot human interaction. The robot is stable because the links are short thus less torque is applied to the arm of the robot. The design requires minimum degrees of freedom.

6.7.3 Disadvantages

Two robots are required thus requiring separate end effectors for each which increases the cost considerably. The robot operation may interfere with some plant growth depending on the size of the plants. The working envelope of this design is limited to the area above the plant trays and just below the lamps. A U shaped track system must be installed in the chamber causing extensive facility modifications. Separate control systems will be necessary in order to operate both robots.

Chapter 7.0 DETAILED COMPONENT DESCRIPTIONS

7.1 PROJECT DELINEATION

Three different groups worked independently on original conceptual designs. These designs were then presented to Mr. Gabor Tamasi of KSC, along with several other interested persons. Two days after the formal presentation, members of all three groups

met and discussed the pros and cons of all of the designs presented. Mr. Tamasi offered opinions as to the designs presented and gave suggestions regarding the areas he felt needed improvement.

Several group members presented additional ideas for consideration. The three groups then selected a basic configuration for the final design. The overall system was then split into three subsystems consisting of the overhead rail, telescopic arm and the vertical and rotational shaft actuator. The three groups then selected one subsystem each to complete.

The groups began working on their individual designs by finding methods to accomplish the required task while remaining within the given design parameters. Upon completion of an initial subsystem design each group presented their designs to Mr. Tamasi in another formal presentation. Mr. Tamasi then gave his observations and recommendations to each group.

The groups then began to refine their final designs. The following report details the Vertical and Rotational Shaft Actuator Subsystem design recommended by NASA/USRA group #1.

7.2 BASIC DESCRIPTION

This design incorporates the use of a combination ball screw / ball spline actuator to control the vertical motion of the CELSS chamber robot arm (Figure 7.2.1). A central mounting structure is mounted to the ball nut and ball spline race. A turntable bearing is used as an interface between the mounting structure and the ball screw nut. This central mounting structure contains a system of motors and pulleys which are used as control systems. One motor is used to rotate the ball nut, while the second motor is used to control the turntable bearing used for rotation of the robot arm. The rotation of the ball nut provides the necessary vertical motion to position the mounting structure along the shaft. The ball spline race adds to the stability of the system and is used to prevent angular rotation of the mounting structure while still allowing for vertical motion. Rotational motion of the robot arm is achieved through the use of a turntable bearing which is actuated by the second motor located within the mounting structure. The robot arm is bolted to the top of the turntable bearing. The upper end of the ball screw / ball spline shaft is attached to a plate which is attached to the overhead rail mounting of the CELSS chamber (Figure 7.2.2).

7.3 DETAILED COMPONENT DESCRIPTIONS

7.3.1 Combination Ball Screw / Ball Spline Shaft

The shaft provides a support with two-dimensional motion capability. Linear and angular motion about its axis is made possible by the use of a combination ball screw / ball spline assembly. This combination is made possible by machining helical groves and concave

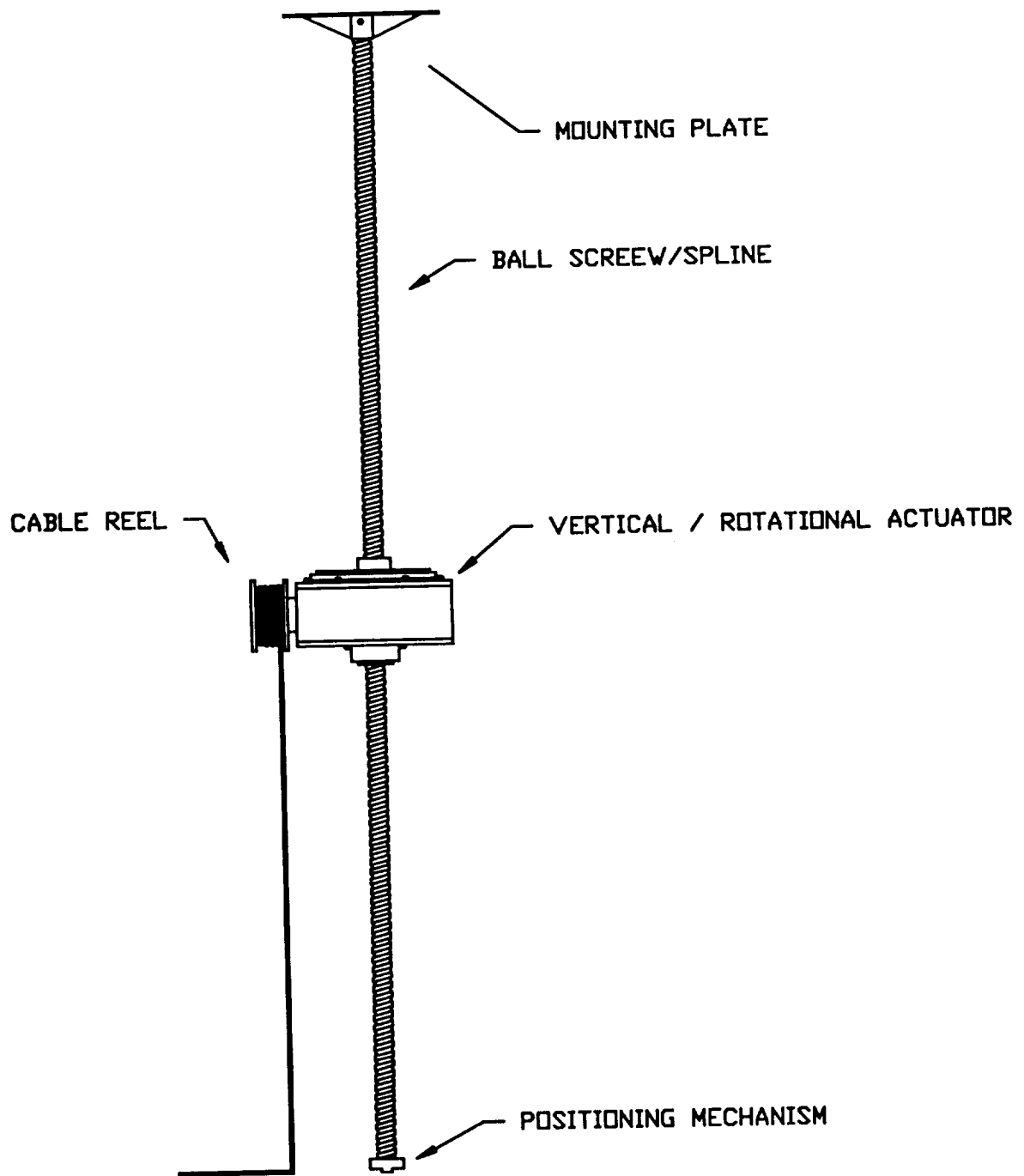

Figure 7.2.1 Vertical and Rotational Shaft Actuator Subsystem

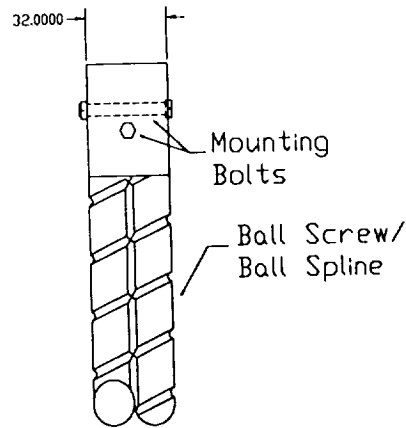

Figure 7.2.2 Top Mounting Portion of Shaft

runs along the longitudinal axis of the shaft. The solid shaft is strong and highly versatile weighing 23.2 kg. The running tracks of the shaft are precisely finished for smooth movement, high positioning accuracy, and long life.

7.3.2 Central Mounting Structure

A circular aluminum casing, the same diameter as the turntable bearing, encloses the ball screw / ball spline subsystem and provides structural support to mount the robot arm (Figure 7.3.2.1). The casing is rigidly attached to the turntable around the vertical shaft. The central robot casing houses the ball screw nut and spline race assemblies (Figure 7.3.2.2). The electrical motors for the turntable bearing and the ball screw nut are housed from the environmental extremes of the cells chamber. There is a circular access hole in the bottom plate for power and computer cabling (Figure 7.3.2.3).

7.3.3 Ball Screw Nut

The ball screw nut is equipped with an internal groove fitted with a circuit of bearing balls that recirculate in the helical grooves between the shaft and nut (Figure 7.3.3.1). The balls and their running tracks are precisely finished for smooth movement, high positioning accuracy, and long life. This anti-friction device converts torque to thrust as the nut is rotated about the fixed axis of the shaft. Rotation of the ball nut is controlled by a motor and pulley assembly which causes the ball nut to translate in the vertical linear direction along the fixed shaft.

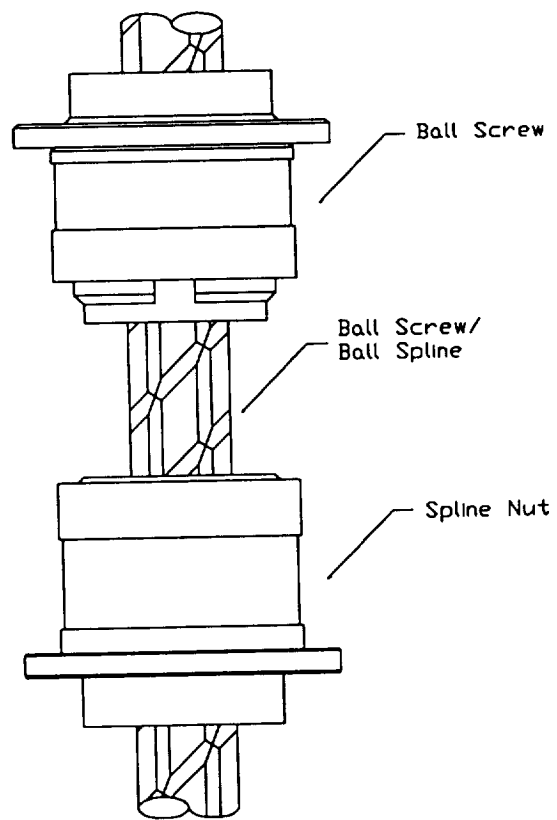

Figure 7.3.2.1 Ball Nut and Ball Spline Nut Assembly

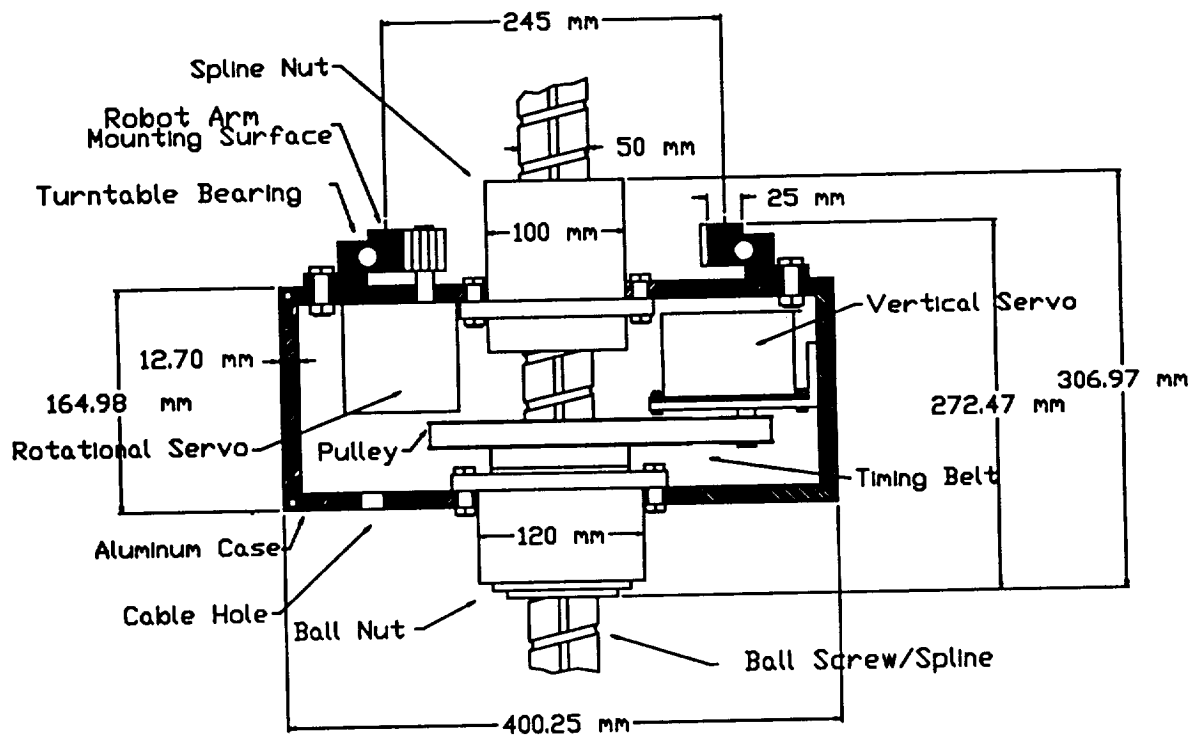

Figure 7.3.2.2 Central Mounting Structure

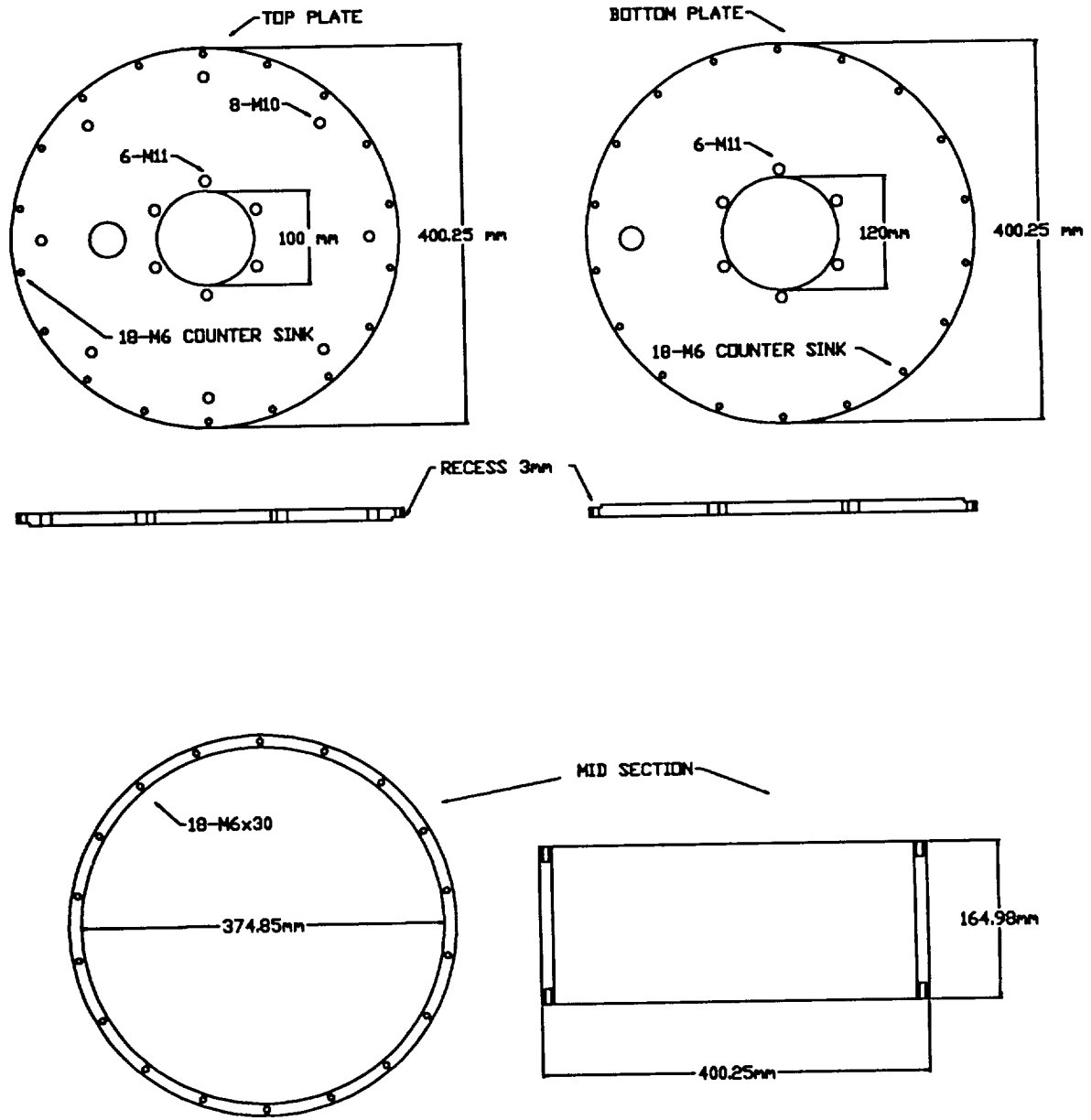

Figure 7.3.2.3 Central Mounting Structure Detail

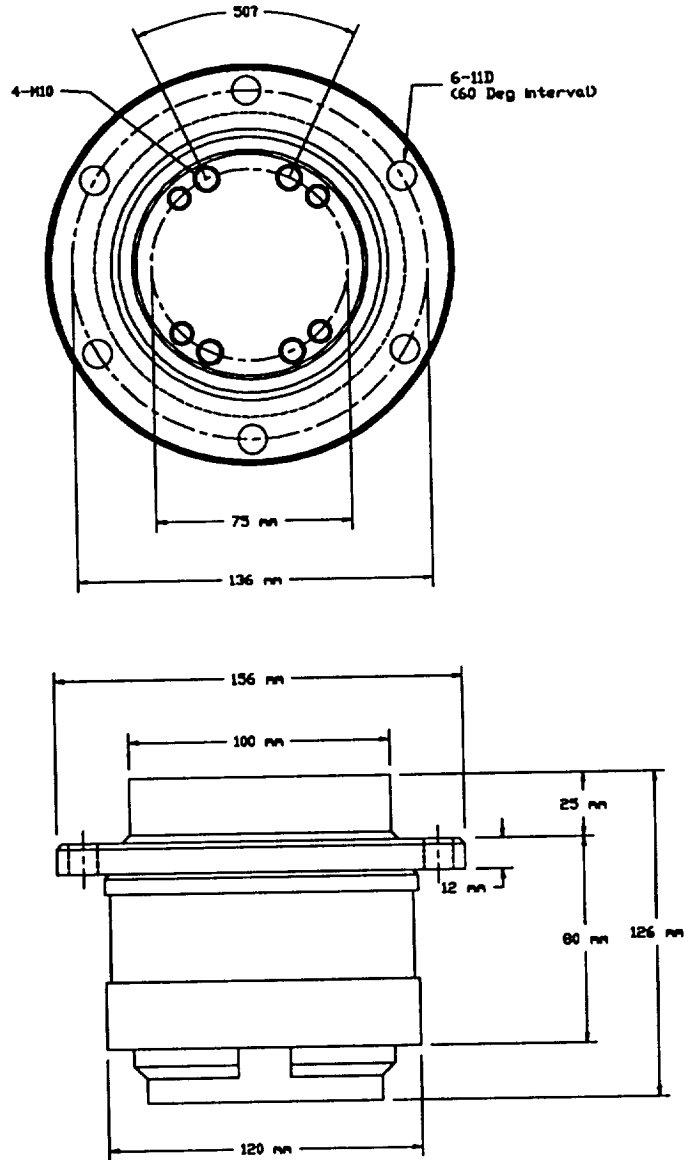

Figure 7.3.3.1 Ball Screw Nut Assembly

7.3.4 Ball Spline Nut

The ball spline nut consists of a closed circuit of bearing balls that mate with the concave races machined along the length of the shaft (Figure 7.3.4.1). As the path of the balls is diverted at the extremes of the spline race into a return circuit, unlimited rolling travel is achieved. There is a smaller force required to achieve axial displacement of spline members while transmitting torque which requires a less powerful motor. The ball spline nut is a coupling device which permits translation while also providing resistance to angular rotation resulting from torsional loads.

7.3.5 Turntable Bearing

A turntable bearing (Figure 7.3.5.1) is bolted to the robot body casing with a vertical axis of rotation. The turntable bearing was chosen because it offers high performance with reduced weight. In this design, the bearings are inside the gear to facilitate an internal rotational drive actuator. The race geometry of these bearings is designed to handle a combination of thrust and moment loads. This makes the turntable bearing ideal for supporting the weight and moment of the robot arm, end effector and load. The outside cylinder ring is bolted to the central mounting structure and the robot arm is bolted to the inside cylinder ring of the turntable. An electrical motor with a gear turns the inner cylinder which positions the robot arm. The turntable bearing is Endura Kote plated for even greater corrosion and wear resistance. The seals are of Buna-n rubber which retain lubrication and exclude contaminants from the CELSS chamber environment.

7.3.6 Lower Support Boot

In the deployed position, the square knob on the bottom of the shaft is positioned in a recessed fitting in the chamber floor. The lower support boot locks the shaft into position for operation. The lower support boot consists of a hinged clasp secured by a pin (Figure 7.3.6.1). The clasp needs to be open when deploying the robot assembly to the center of the chamber. After the shaft is fit in both the overhead rail operational position and in the recessed fitting in the chamber floor, the clasp is closed around the shaft and pinned.

7.3.7 Cable Reel

The cable reel retractor allows the cabling to be drawn from a spring loaded reel mounted to the side of the central mounting structure (Figure 7.3.7.1). When the central mounting structure is lowered, the excess cable is retracted onto the spring loaded reel. Upon deployment of the robot system, the cable is attached to the floor of the chamber directly below the retractor.

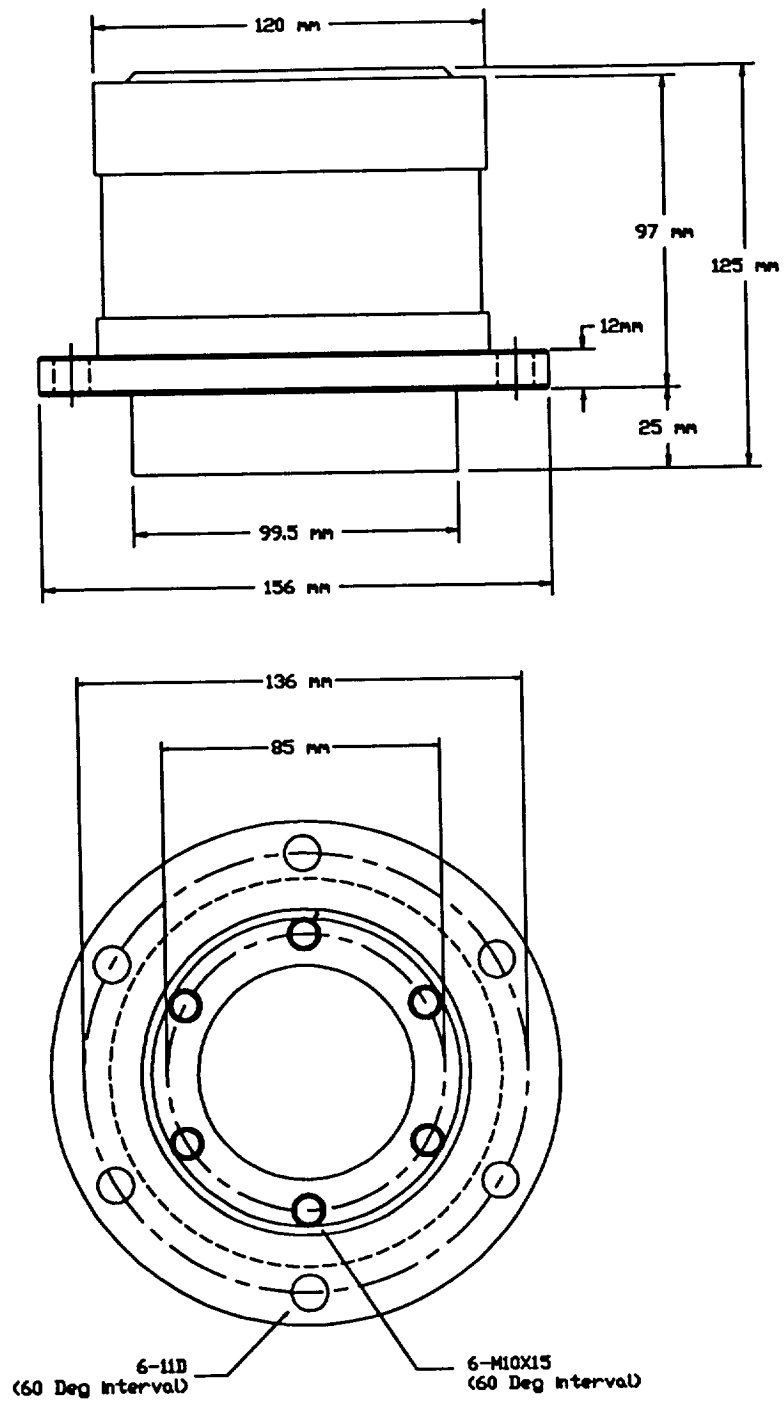

Figure 7.3.4.1 Ball Spline Nut Assembly

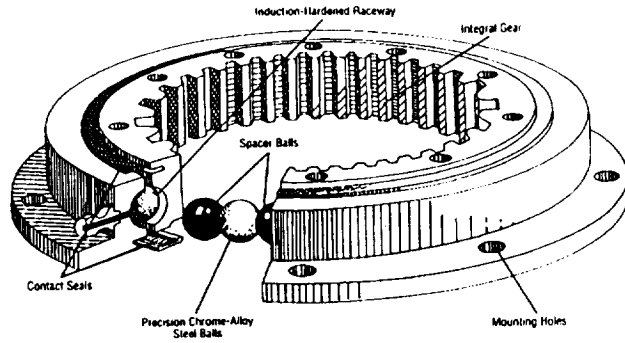

Figure 7.3.5.1 Turntable Bearing

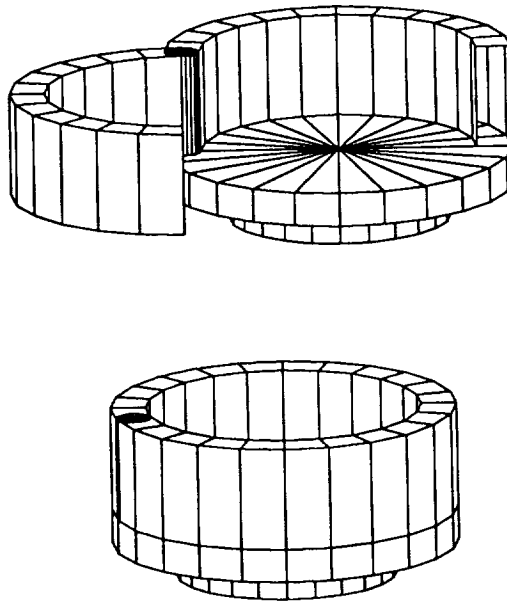

Figure 7.3.6.1 Lower Support Boot

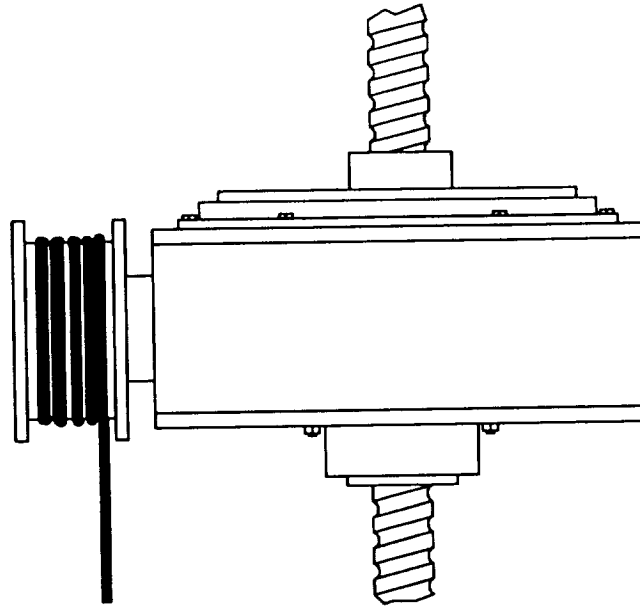

Figure 7.3.7.1 Cable Reel

Chapter 8.0 ANALYSIS OF DESIGN

8.1 EXPLANATION OF CRITICAL ANALYSIS

A critical analysis modeling the robot arm as a cantilever beam indicates it can handle the stress and moment of the anticipated loads on the combination ball screw / ball spline assembly. Using the beam decoder finite element module, the deflection and stress for a 30 node finite element model were generated. The ends of the poles were constrained from x,y,z translation and rotation. Two point loads of 298 kg were applied on the shaft to simulate the moment created by the robot arm. The maximum deflection was created at a node location of 0.75 m length, when the arm was extended to its full length of 1.83 m. The maximum deflection was 3.9 mm at the end effector.

8.1.1 Combination Ball Screw / Ball Spine Shaft

THK Corporation manufactures the Sehma Series "Robotte" combination ball screw / ball spline shaft. The combination ball screw / ball spline shaft was chosen because it can linearly translate relative to the ball nut and can also rotate about its longitudinal axis. The solid shaft is 0.050 m diameter and 3.1 m in length. The shaft is made of heat treated carbonized steel which resists the humid environment of the CELSS chamber.

The loads applied in the stress analysis of the shaft were computed with a safety factor of 2.5. The Algor beam element editor module was used as the input processor for the boundary conditions and forces applied. All stress units were given in Pascals. All

deflection are given in meters. The maximum angular deflection computes at 0.1 degrees which leads to a end effector deflection of 3.9 mm with a safety factor of 2.5. In the analysis of the shaft, 25 nodes were used.

8.1.2 Central Mounting Structure

The central mounting structure consists of three separate parts machined out of aluminum, two flat circular plates and a cylindrical component. In the upper flat plate, holes are drilled to mount the spline race, the turntable bearing and the motor that drives the turntable bearing. In the lower flat plate, holes are drilled to mount the structure to the ball screw nut. The motor which drives the ball screw nut is mounted to the cylinder wall. The motors selected should have a 1800 servo RPM (Appendix C). The cylinder's outside diameter is 0.4 meters and its height is 0.224 meters. The two flat plates are bolted to the cylinder with evenly spaced bolts. (Figure 7.3.2.2)

The CMS was analyzed using Algor, a finite element analysis software. The structure was modeled as two octagonal plates joined by a perpendicular wall to approximate a three dimensional cylindrical housing. The material property used to model the structure was aluminum with a 1.27 cm thickness. The data results conclude the deflection of the structure is negligible (0.01 mm) with the forces applied.

8.1.3 Ball Screw Nut

The ball screw nut assembly is available through THK Corporation and Thomson Saginaw. The ball nut is coated with a black oxide or zinc plate coating, and could be lubricated with a lithium based lubricant which is inert to the environment (Figure 7.3.3.1).

8.1.4 Ball Spline Nut

The ball spline nut assembly is available through THK Corporation and Thomson Saginaw. Their ball nut systems provide high speed, antifriction linear motion under heavy torsional loads. The spline nut assembly has a low coefficient of friction (0.007 maximum) and is manufactured with a hard material (R/C 56) to ensure efficient operation and durability in environments with a temperature range of -53 to 149° C (Figure 7.3.4.1).

8.1.5 Turntable Bearing

The turntable bearing is available through Kaydon Incorporated; however, it will have to be custom made due to its nonstandard size. Data supplied by the manufacturer indicates the load capacity of the bearing will exceed required specifications. Typical applications include cranes and heavy equipment operations.

8.1.6 Lower Support Boot

The purpose of the lower support boot is to increase the stability of the shaft in the deployed position. The Algor analysis of the shaft was based among other things on the assumption that both ends were fixed. The support boot holds the shaft firmly in the recessed fitting in the CELSS chamber floor.

8.1.7 Cable Reel

The cable reel contains both the power cabling as well as the computer control cabling. The cable reel selected is designed for cable rated 9-35 amps for either 110 or 220 services. The cable reel is of the spring rewind type. Cable reels can be bought off the shelf in various sizes. The size selected may depend on the bin radius of the computer cabling to control the robots operation.

Chapter 9.0 OBSERVATIONS & RECOMMENDATIONS

The function of this subsystem is to position the robot arm vertically along the shaft and rotate the arm about the shaft for angular positioning. Other issues considered were the interface compatibility between this subsystem and the overhead rail structure, the robot arm and the connection of the shaft to the floor. The functionality of this subsystem was achieved through a design consisting of a single ball screw / ball spline shaft, a central mounting structure equipped with a turntable bearing and a system of motors and pulleys, and a ball screw hand jack.

This subsystem design for the NASA/USRA Advanced Design Program was evaluated for maintenance, safety, component complexity and operational performance requirements within the CELSS chamber. The design generally requires tradeoffs between complexity of mechanisms, safety, maintenance and general requirements. Cost, weight, and modification to the CELSS chamber were other major issues considered.

The major component cost is for the ball screw / ball spline shaft. The reason for this large expense is due to non standard length of the shaft. The 3.1 m shaft has to be custom made by the manufacturer. The shaft's 50 mm diameter is standard allowing the use of a standard ball screw nut and ball spline nut. The total estimated cost of the subsystem is \$ 7,400 (Appendix D).

There is a commercially available turntable bearing made with an exterior gear configuration. The design of the CMS can be altered to use this type of turntable bearing instead of the internal gear configuration. This is a viable option to consider because it reduces the cost.

The shaft itself weighs 25% of the overall estimated weight of the subsystem. Light weight aluminum was used in the construction of the CMS to reduce its weight. The total weight estimate for the subsystem is 97 kg (Appendix E).

Depending on the floor thickness in the CELSS chamber, the knob on the lower support boot may need to be 1.25 cm instead of 0.635 cm as recommended in this report.

The current configuration of the CELSS robot does not comply with the specification for the end effector to reach 0.254 m above the chamber floor. The CMS was designed as small as possible to house the motor and pulley assemblies. In addition, the lower support boot was redesigned to reduce its height dimension; however, the CELSS robot system still does not meet the specification. Designing the telescopic arm to mount centrally between the CMS top and bottom plates versus its current top mounted position will meet the design specification mentioned above.

The servo motors may need gear reduction to provide required torques (Table 1). If motors are not available that will fit into the CMS, the current CMS dimension can be modified with minimal effort.

TABLE 1
Servo Motor Ratings

	Torque (F.S. = 2)	RPM
Rotational	0.36 Nm	47
Vertical	2.6 Nm	900

Chapter 10.0 ACKNOWLEDGEMENTS

We greatly appreciate and acknowledge support from NASA, USRA, and the UCF Mechanical & Aerospace Engineering Department. Many people provided assistance in our senior design project. We would like to give special recognition to Ms. Pam Armitage, and Mr. Gabor Tamasi. Many professors have assisted in our project this semester. Special thanks go to Dr. A. H. Hagedoorn, Dr. Antonio Minardi, Dr. Charles E. Nuckolls for their guidance and advice.

SECTION III

TELESCOPIC ARM SUB-SYSTEM

CONCEPTUAL DESIGN

- * FLOOR MOUNTED, FIXED AND TELESCOPIC ARM
- * FIXED POLE MOUNT, FIXED AND TELESCOPIC ARM
- * SCISSOR CEILING ROBOT
- * RACK AND PINION CEILING ROBOT
- * CENTER SCREW COLUMN ROBOT
- * TELESCOPIC, PULLEY CEILING ROBOT
- * FLOOR MOUNTED TRACK ROBOT
- * CENTER COLUMN, SIDE WALL STORAGE
- * CEILING MOUNTED, FIXED OR TELESCOPIC ARM ROBOT
- * CENTERED WALL MOUNTED TRACKS
- * TOP MOUNTED PULLEY, MULTIPLE FIXED ARMS

FINAL DESIGN

- * CRITICAL PARTS
- * MATERIALS
- * LINEAR ACTUATOR
- * TRIP MECHANISM
- * ROLLERS AND BEARINGS
- * CRITICAL ANALYSIS
- * OBSERVATIONS AND RECOMMENDATIONS

Chapter 11.0 INTRODUCTION

This chapter reports the CELSS robotics project is at the 90% completion stage of the design phase. The robotic arm development is discussed in detail by group 3 in the following report. The other two components of the over all robot design: (1) the rail or track system which guides and supports the entire system and (2) the center column which interfaces with the arm; are covered in detail by Group One and Group Two, respectively.

The report shows the robotic arm designed for the CELSS Project meets or exceeds all parameters set by NASA, the Military Specifications which are included in the report, and is adaptable to the physical restrictions of the CELSS capsule (Appendix F, Specification). The overall design is shown in Figure 11.1.

Chapter 12.0 DESIGN PHASE

12.1 FLOOR MOUNTED, FIXED & TELESCOPIC ARM ROBOT

The double arm floor mounted designs (Figure 12.1.1 and Figure 12.1.2) possess pin joint connections at the base of the arm, connecting the two arms, and at the point where the arm meets the end effector. Arm configurations vary with combinations of fixed and telescoping arms. Both types are connected to a fixed floor mount.

12.1.1 Advantages

This robot is a simple design and incorporates a minimum of moving parts^{18a}. This robot may be commercially available. The fixed arms may be available as off the shelf parts thereby minimizing fabrication costs. This robot could be designed to carry a larger payload than required by the design requirements if desired. The cost of developing this robot is low due to the small number of required parts.

12.1.2 Disadvantages

This robot may not be able to access all parts of the CELSS chamber. This design may interfere with existing electrical conduit located along the chamber wall. There may be some problems with interference with the existing experimental shelves.

12.1.3 Feasibility

The feasibility of this robot is good provided it can be designed to reach all areas of the CELSS chamber.

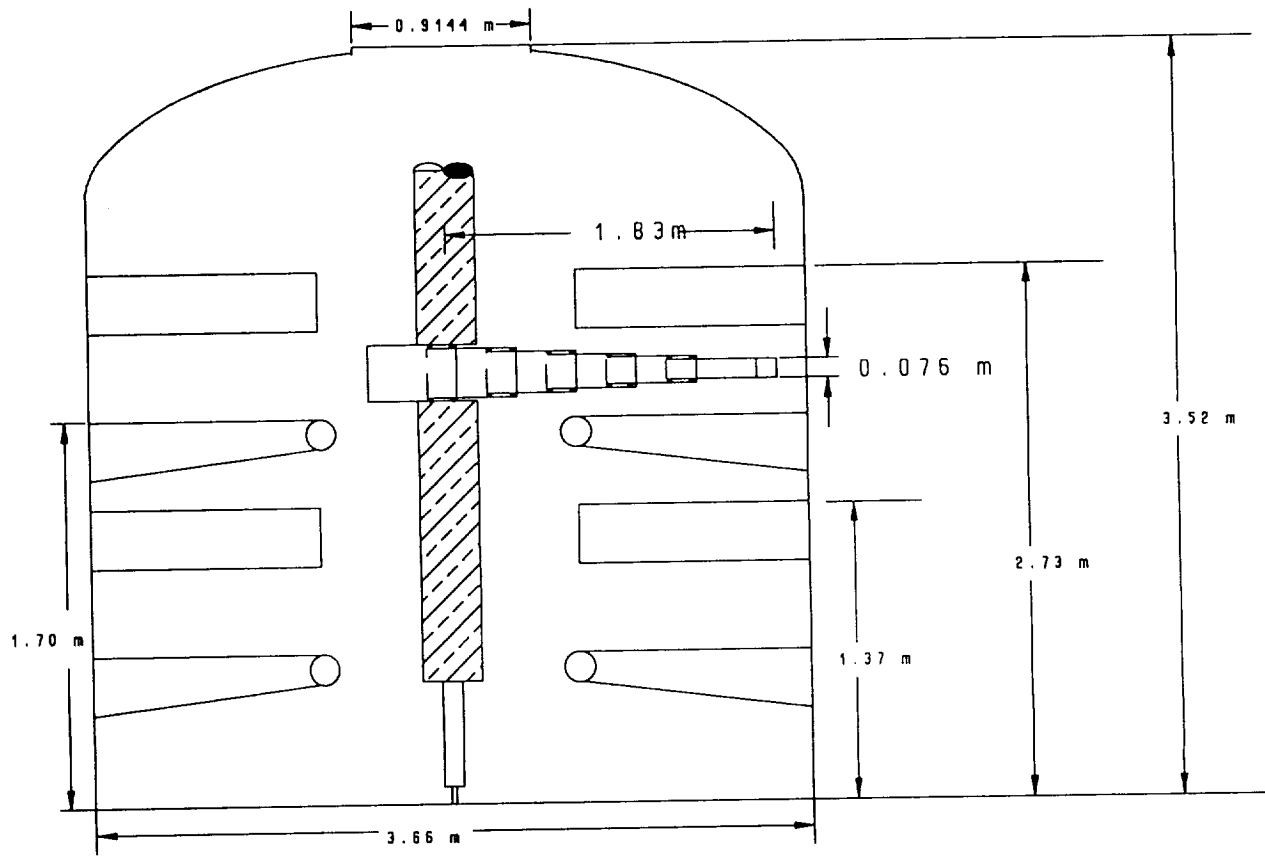
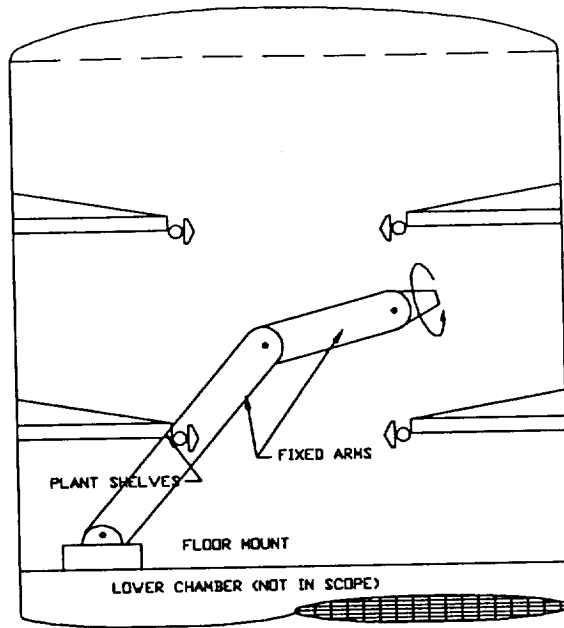
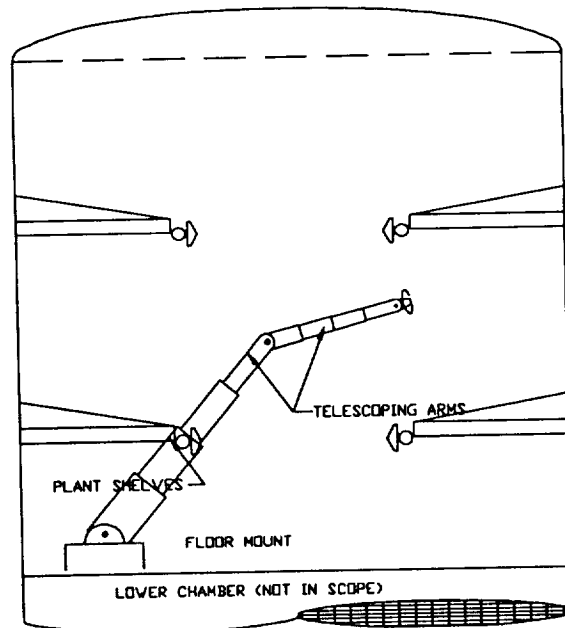

Figure 11.1 Overall Robot Arm Design



ELEVATION
NOT TO SCALE

Figure 12.1.1 Floor Mounted Fixed Arm



ELEVATION
NOT TO SCALE

Figure 12.1.2 Floor Mounted Telescopic Arm

12.2 FIXED POLE MOUNT, FIXED AND TELESCOPIC ARMS ROBOT

An off-center mounted pole, fixed at the top and bottom of the chamber holds a call screw and robot arm configuration. The arm itself may be composed of several links of fixed arms (Figure 12.2.1) or one telescopic arm (Figure 12.2.2).

12.2.1 Advantages

This robot requires a small number of moving parts. The arm system may stow floor level or at the ceiling. This robot is low cost due to the small number and the possible commercial availability of parts required.

12.2.2 Disadvantages

This design may conflict with existing plant shelving. Anchoring to the chamber at the top may be difficult due to the slope of the ceiling. Reachability may be restricted to the shelving nearest the column. The long arm length results in increased moment loads on the arm and possible reduced load capacity.

12.2.3 Feasibility

This design has fair feasibility because of the reachability restrictions and increased moments on the robot arm.

12.3 SCISSOR CEILING DESIGN

A center, roof-mounted rack-and-pinion (Figure 12.3.1) or scissor (Figure 12.3.2) configuration raises and lowers the arm attachment at the center of the chamber. The robot arm may be telescoping, fixed or scissors arrangement and moves in a 360° rotation.

12.3.1 Advantages

This design is simple and contains no complicated mechanisms. The collapsible scissor type extension has the capability of heavy lift, and benefit of small storage volume when in the stowed position. The cost of this design is reasonable.

12.3.2 Disadvantages

The scissors extension creates a problem with the control and power cables^{18b}. The cables could be easily pinched if not firmly secured. It is also difficult for the scissor extension to counter any moments developed while the extended arm lifts a load.

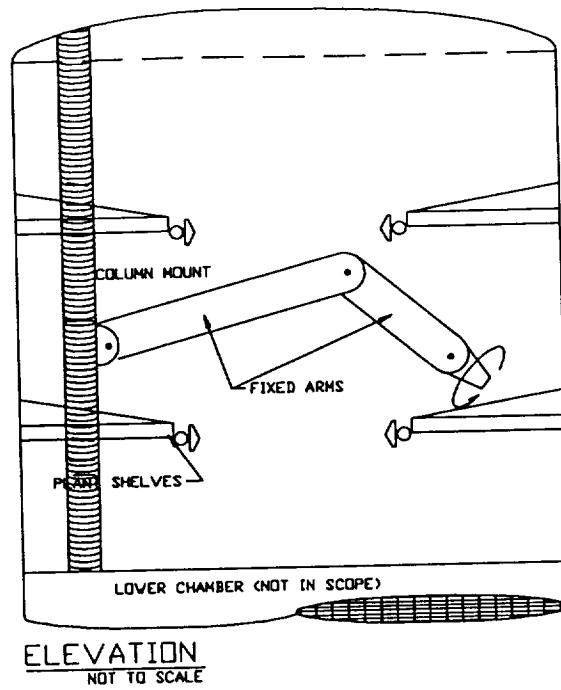

Figure 12.2.1 Fixed Pole Mounted, Fixed Arm

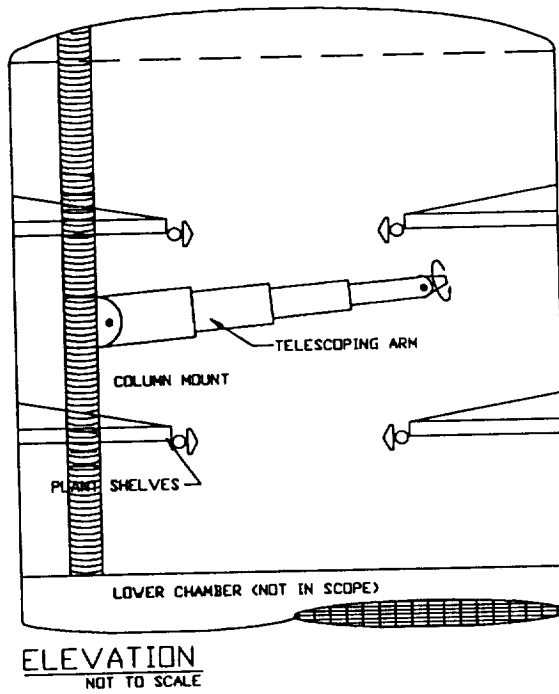
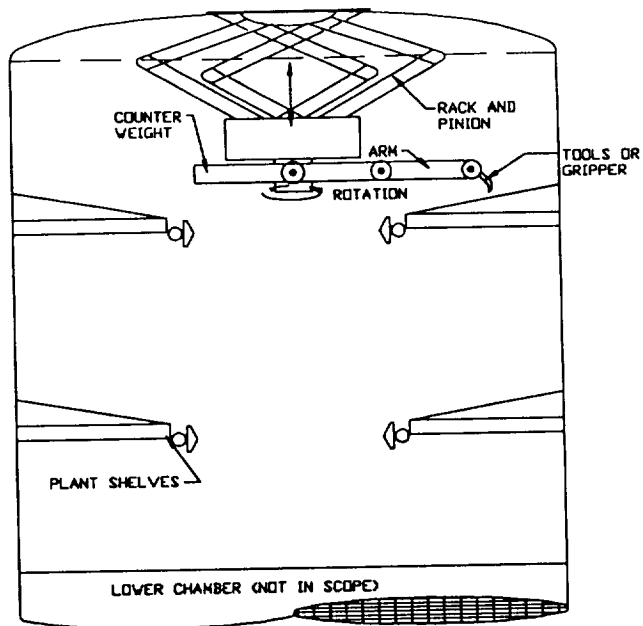
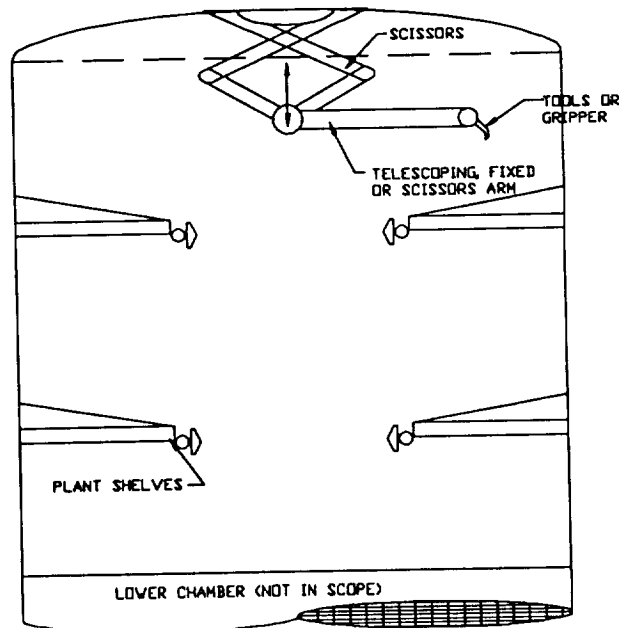

Figure 12.2.2 Fixed Pole Mounted, Telescopic Arm



ELEVATION
NOT TO SCALE

Figure 12.3.1 Rack-and-Pinion Ceiling Design



ELEVATION
NOT TO SCALE

Figure 12.3.2 Scissor Ceiling Design

12.3.3 Feasibility

The feasibility of this design is very good. Many of the parts can be procured through robotics manufacturers.

12.4 RACK AND PINION CEILING DESIGN

A center roof-mounted telescopic column (Figure 12.4.1) raises and lowers the arm attachment at the center of the chamber. The robot arm has a fixed link with counterweight, to pivot up and down about the bottom center of the column. The fixed link also provides for 360° rotation. An end link works as a single reduction telescope for fine adjustment of the end-effector location.

12.4.1 Advantages

The telescoping main pedestal and the arm is extended by a rack and pinion mechanism which is cleaner than a hydraulic piston when in use. The main pedestal is a very stable structure and provides stability to the entire robot arm by countering any moments developed during lifting of loads. The robot is designed to stow overhead against the ceiling, allowing access to the entire chamber floor by technicians.

12.4.2 Disadvantages

One of the disadvantages is the difficulty of accessing the robot on the ceiling for maintenance and repair. There may be some difficulty in routing control and power cables to prevent interference when in use^{18c}. The installation may require additional modifications to the ceiling to ensure the ceiling is strong enough to support the expected working loads of the final design.

12.4.3 Feasibility

The design is highly feasible and is based on other working models used in industry today. It has the flexibility of using either an AC or DC power source.

12.5 CENTER SCREW COLUMN DESIGN

The robot arm attachment moves up and down the center column using a screw drive^{18d} (Figure 12.5.1-3). The design shown in Figure 12.5.1 is unique in that the center screw column retracts through the roof of the chamber into a sealed conduit above the chamber. For stowing, the robot latches to the ceiling and pulls the unlocked center screw column out of the chamber. The robot is aided in lifting the heavy column by counter balancing springs located in the outside conduit.

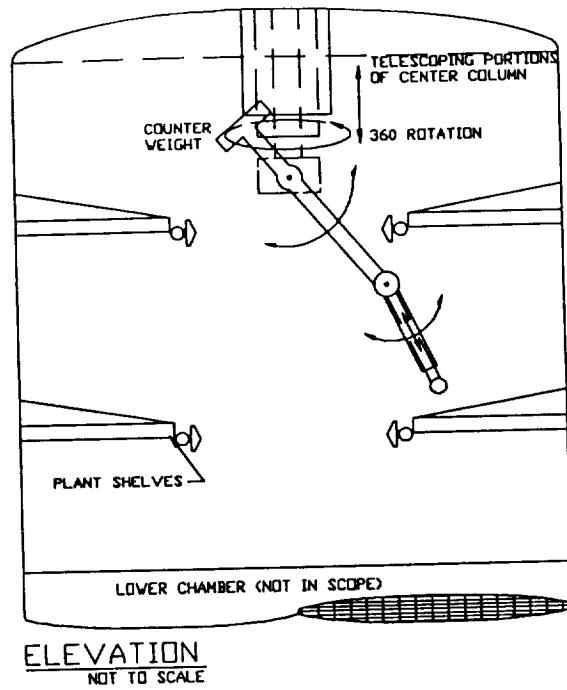

Figure 12.4.1 Center Vertical Telescopic Column Design

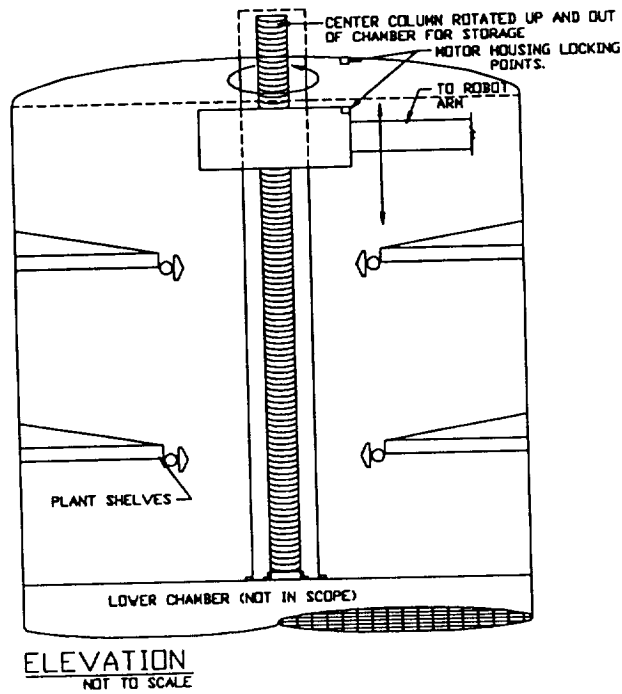

Figure 12.5.1 Center Screw Column Design

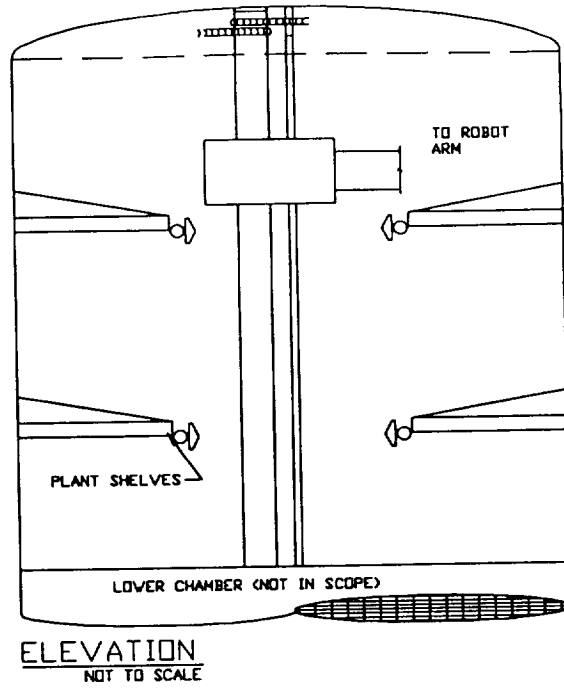

Figure 12.5.2 Center Screw/Chain Column Design

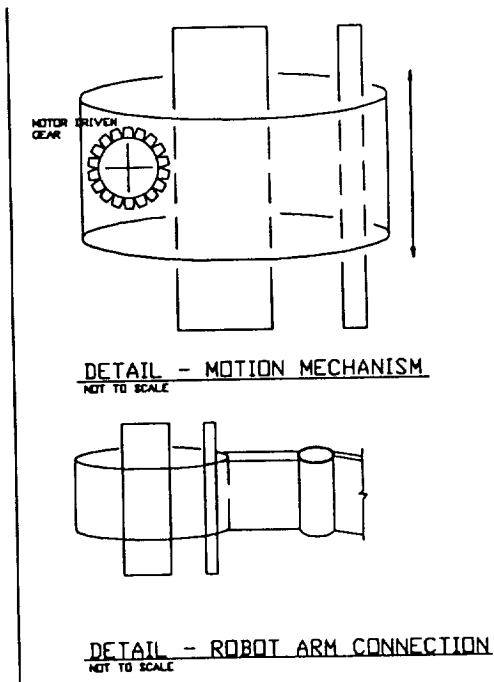

Figure 12.5.3 Detail

12.5.1 Advantages

This design is possibly the most stowable as far as the inside chamber is concerned. The bulk of the system is stored outside the CELSS chamber. In the deployed position, this design has a full range of motion of the entire chamber. The screw drive is very reliable and strong. Minimal down time is expected because all working parts are contained in the actual robot body and arm. This design has the potential to expand to the lower half of the chamber if needed.

12.5.2 Disadvantages

The biggest disadvantage of this design is the sealed conduit that extends about seven feet over the chamber. A disadvantage is the hole has to be cut on the top of the chamber to push the screw bar through. This compromises the integrity of the chamber.

12.5.3 Feasibility

With adequate clearance above the chamber this design has very good feasibility.

12.6 TELESCOPIC, PULLEY CEILING DESIGN

A center, roof-mounted pulley with a motor, drives a single loop chain, which raises and lowers the robot arm attachment similar to a block and tackle configuration (Figure 12.6.1). The robot arm attachment moves up and down along a path established by two lightweight stabilizer columns, which control stability in the z-axis. The robot arm contains a counterweight to provide stability in the x-axis, and several fixed arm links to provide reach to the chamber perimeters.

12.6.1 Advantages

This design has excellent stowability since modification of the chamber is not necessary to provide clear home position. The strength of this design comes from its cost effectiveness. The reachability is as good as any other top design model because it extends from top to bottom and the arms 360° degree rotation permits full access of the chamber. This design reaches any point in the CELSS chamber.

12.6.2 Disadvantages

A disadvantage is that the whole system is gravity dependent. This design is able to achieve resonant frequency during its oscillating motion when the telescopic arm is fully extended. It also uses the pulley system which may result in a short life span.

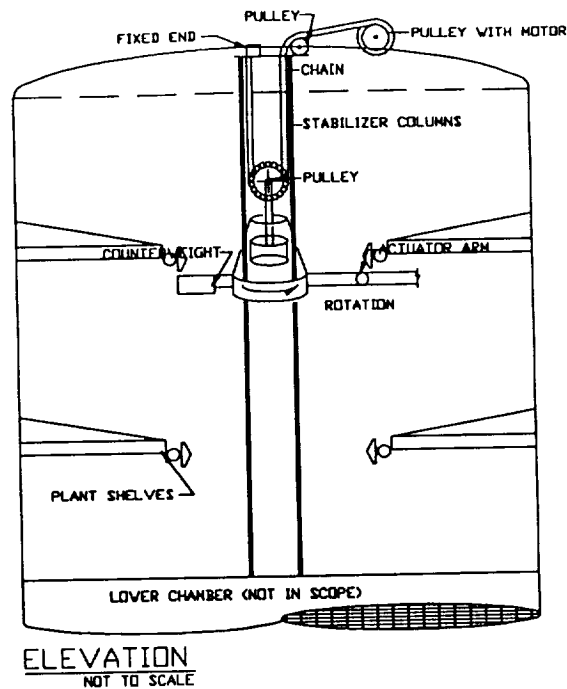

Figure 12.6.1 Telescopic, Pulley Ceiling Design

12.6.3 Feasibility

The feasibility is low even though the design demonstrates an excellent combination of reachability and cost effectiveness. Due to its instability practical tasks are difficult to perform.

12.7 FLOOR MOUNTED TRACK DESIGN

A freestanding robot lifts in a telescoping fashion, from its base (Figure 12.7.1). The base moves about the chamber on a circular track, which has a stowing leg that routes the robot to a location under the bottom plant shelf. The robot arm is a fixed arm configuration with a ball socket joint for end-effector attachment.

12.7.1 Advantages

This robot will have a range that will cover the entire CELSS cylinder, and perform the tasks specified by KSC. The robot will be guided by a circular track system (the radius will equal approximately the radius of the chamber minus the length of the shelves) located with its center coincident with the center of the chamber. The advantages of this robot is its ability to reach everywhere in the chamber in case the chamber is modified. Also, the robot is completely inside the chamber thereby avoiding any leaking associated with ceiling or wall mounted robots. There will be a section of track

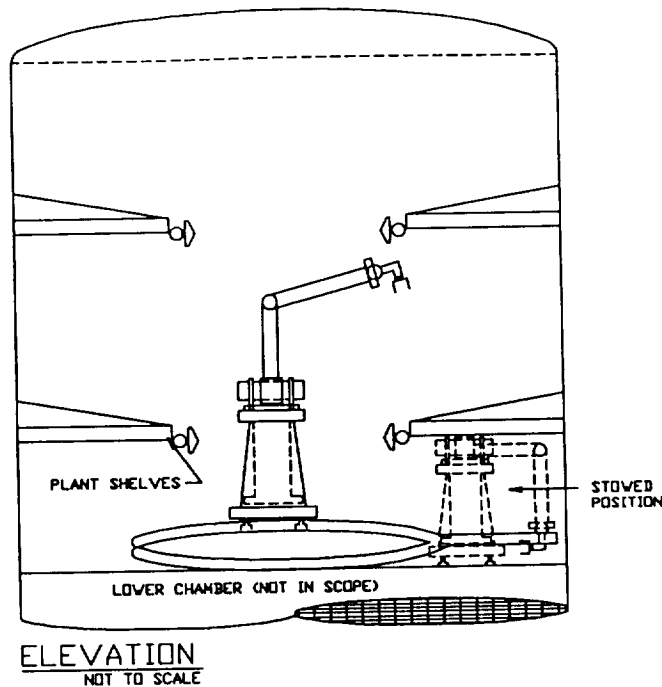

Figure 12.7.1 Floor Mounted Track Design

extending from the circular track to a location under the first shelf to maximize stowability. Furthermore, since the robot will be at a location very near the object it will be lifting, the arm will be considerably shorter than a robot located at the center of the cylinder. This will decrease the moment arm enabling more weight to be picked up or a less costly material to be used. Lastly, the robot should not be expensive compared to other types of robots. This robot can be easily removed for repair or replacement.

12.7.2 Disadvantages

This particular robot's track system will not be easily removed. Electric power and control cables trail the robot since hydraulics can not be used to raise the top half of the robot.

12.7.3 Feasibility

This design has excellent feasibility by virtue of its compact design and stowability. Modifications to the chamber are minimal. Maintenance is simple because the robot may be removed from the space to be serviced. Cost may be high if this type of robot is not commercially available.

12.8 CENTER COLUMN WITH SIDE WALL STORAGE

A center-mounted column rolls out on a top and bottom track, from its side wall stowed position to a locked center chamber position (Figure 12.8.1-4). The robot arm moves up and down the column on a ball screw and has three planar links. These planar links fold in on top of each other to make the assembly more compact in the stowed position.

12.8.1 Advantages

The tracks provide a path for the center column to move from the center locked position along the wall. The ball screw mechanism which moves the robot arm up and down the center column is a standard, off-the-shelf configuration which has lower cost. The large contact surface between column surface and cowling, which supports the robot, provide very high strength. This design has few parts and a relatively simple mechanism.

12.8.2 Disadvantages

Modifications to the chamber will be required for existing electrical and other components along the wall where the column stows away. Measurements at the center of the chamber will be impossible to obtain.

12.8.3 Feasibility

The feasibility of this design is very good for gravity and non-gravity situations. There is a good range of reachability, height adjustment, and reasonable rigidity¹⁹. Chamber modifications should be minimal to maintain required clearances for electrical components.

12.9 CEILING MOUNTED, FIXED OR TELESCOPING ARMS

This design is a center, roof-mounted arrangement with two fixed arms (Figure 12.9.1). Pivot points are located near the point of attachment to the roof and at a point approximately half way down the length of the arm. Figures 12.9.2 through 12.9.4 provide variations in fixed and telescopic arm configurations..

12.9.1 Advantages

The ceiling mounted design provides very good stowability and flexibility in position as well as 360° rotation. All control and power wiring are contained outside the chamber. The design is simple in construction and has a low installation cost.

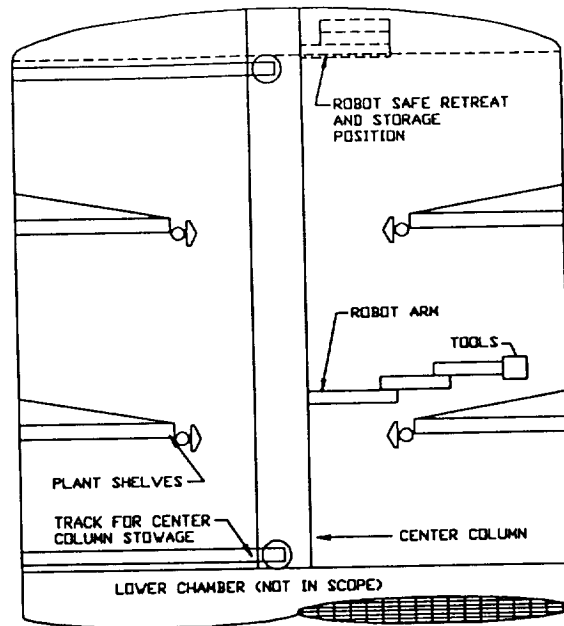

ELEVATION
NOT TO SCALE

Figure 12.8.1 Center Column with Side Wall Storage

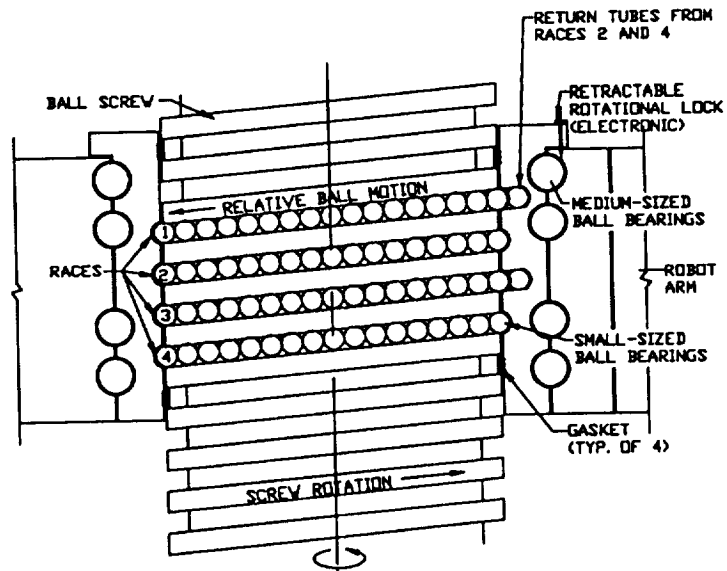

DETAIL - CENTER COLUMN / ROBOT ARM INTERFACE
NOT TO SCALE

Figure 12.8.2 Detail

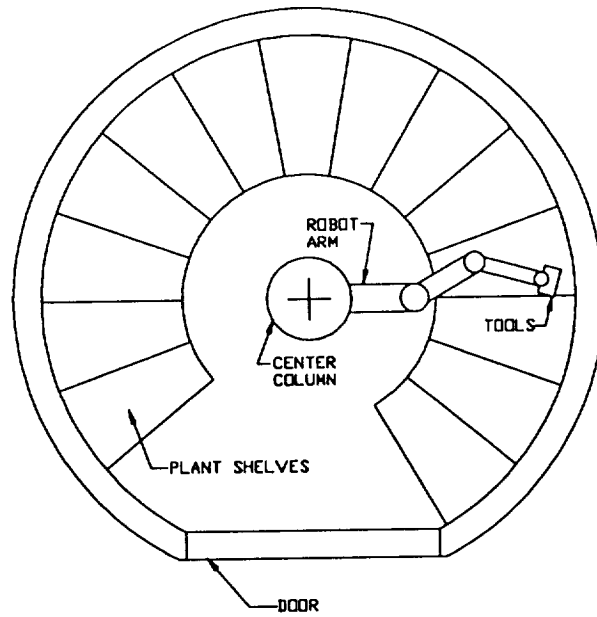

PLAN VIEW
NOT TO SCALE

Figure 12.8.3 Plan View

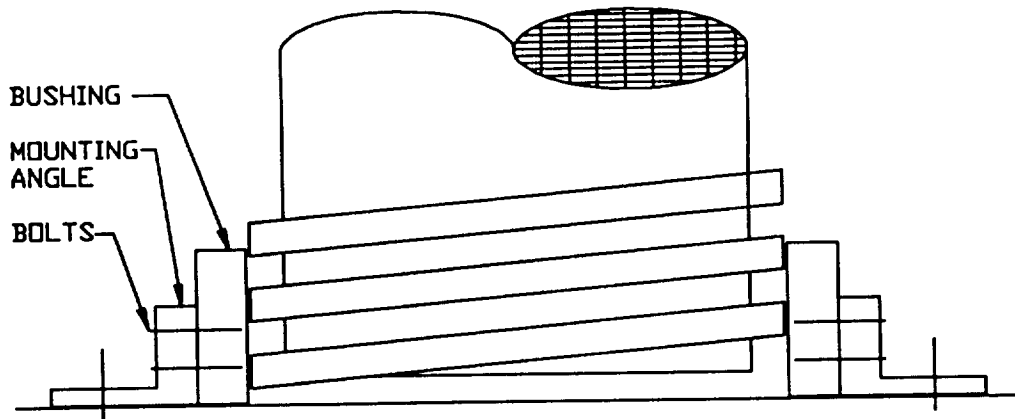

DETAIL - CENTER COLUMN BASE SUPPORT

NOT TO SCALE

Figure 12.8.4 Detail

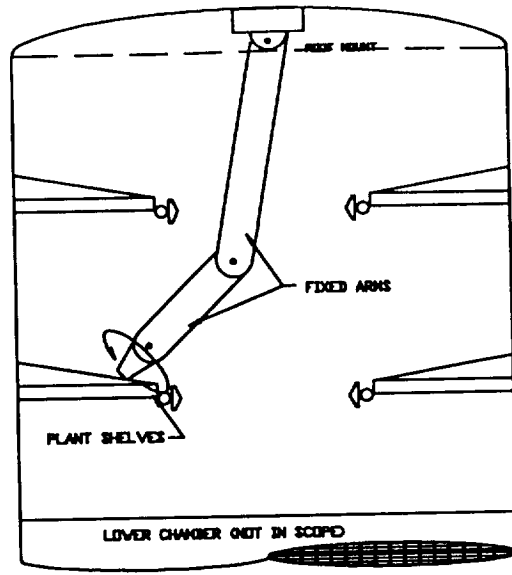

ELEVATION
NOT TO SCALE

Figure 12.9.1 Ceiling Mounted, Fixed Arms

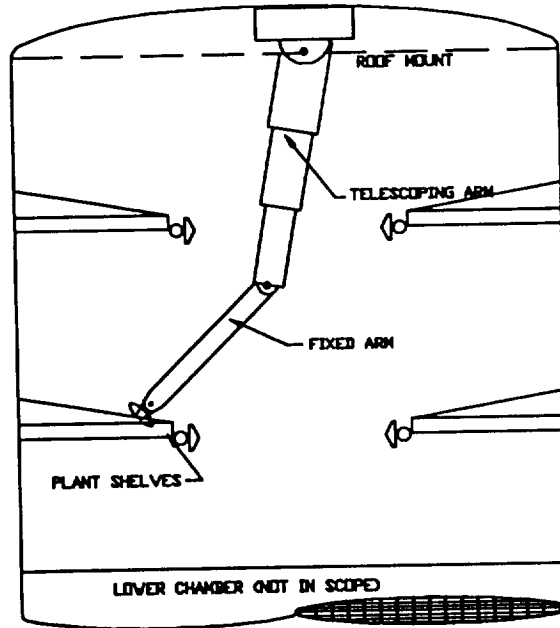

ELEVATION
NOT TO SCALE

Figure 12.9.2 Ceiling Mounted, Fixed and Telescoping Arms

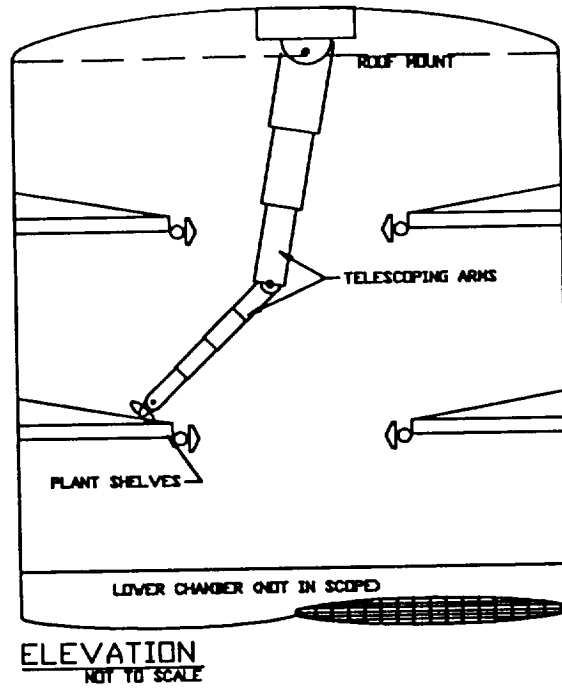

Figure 12.9.3 Ceiling Mounted, Telescopic Arms

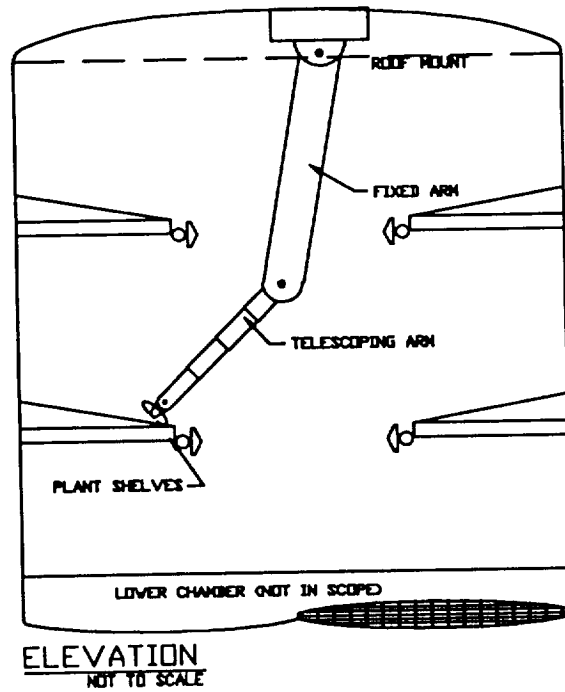

Figure 12.9.4 Ceiling Mounted, Telescoping and Fixed Arms

12.9.2 Disadvantages

This design presents maintenance access problems. It may be hard to reach and service. The existing hatch opening at the top of the chamber would need to be relocated. Control would be difficult due to various degrees of freedom acting simultaneously.

12.9.3 Feasibility

Feasibility for this design is good. Arm link lengths will require careful coordination to ensure that the top rack is reached by the end effector. Careful calibration will be required to ensure that the top rack is left undisturbed when the bottom rack is the target.

12.10 CENTERED WALL MOUNTED TRACKS

The basic feature of this design is a track mounted along the perimeter walls of the chamber halfway up the height of the chamber (Figure 12.10.1). The robot arm attaches to the track, working inward from the perimeter. The robot arm may be fixed, telescoping (Figure 12.10.2) or a combination (Figure 12.10.3). The track may be a single, center mounted track (Figures 12.10.1 through 12.10.3) or a dual track at center and top positions in the chamber (Figures 12.10.4).

12.10.1 Advantages

The wall track mounted design has good reachability and 360° coverage. It is a more compact design and the shorter arm length may increase load capacity with reduced moments. The robot arm may handle variable and complex movements. Maintenance is good from an access standpoint. Stowability is good.

12.10.2 Disadvantages

This design requires coordination with door openings and shelf mounting heights. Plants may be disrupted or damaged as the arm moves around the circumference. Installation is difficult and expensive. The robot arm, working from the perimeter may reduce stability. Reliability is poor due to complexity.

12.10.3 Feasibility

This design has only a fair rating in feasibility because of the large amount of modification to the existing chamber that may be required. It is costly to implement and difficult to expand to the lower chamber.

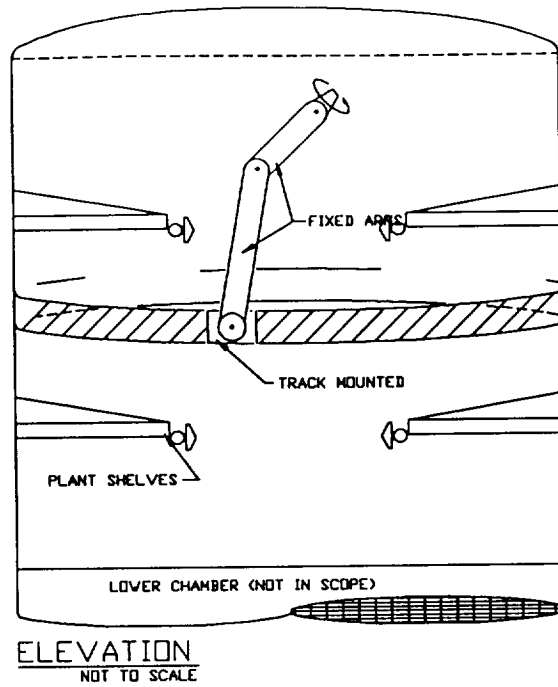

Figure 12.10.1 Center Wall Mounted Track, Fixed Arms

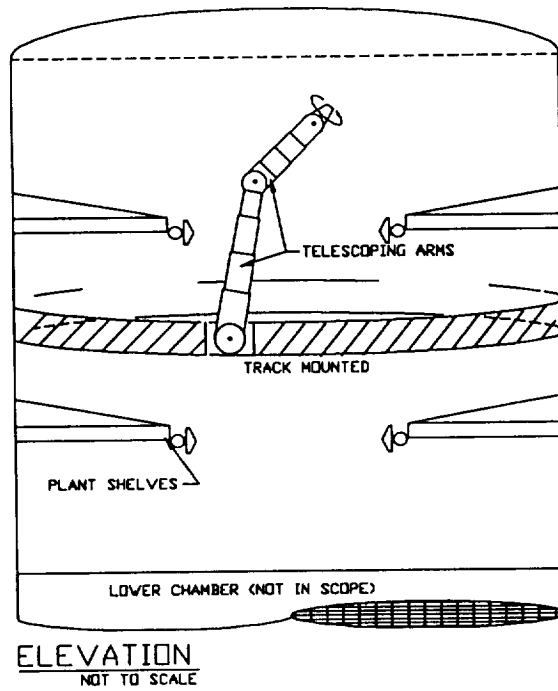

Figure 12.10.2 Center Wall Mounted Track, Telescoping Arms

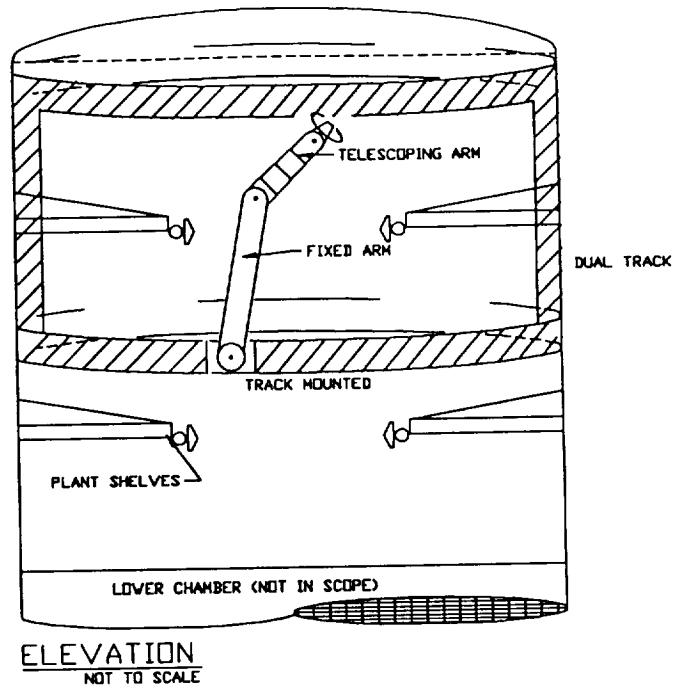

Figure 12.10.3 Center Wall Mounted Dual Track, Hybrid Arm

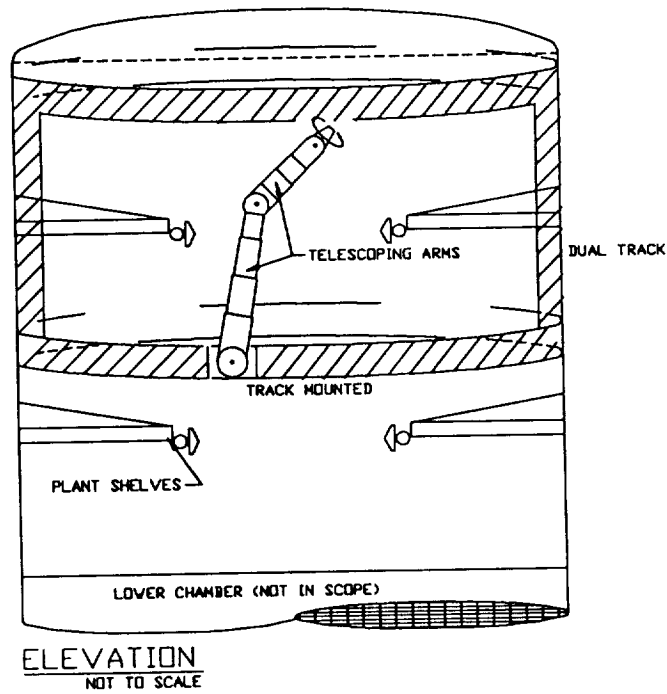

Figure 12.10.4 Center Wall Mounted Dual Track, Telescoping Arms

12.11 LOW WALL MOUNTED TRACK

Similar to the center wall-mounted track, this design uses the chamber perimeter and a shortened robot arm (Figures 12.11.1 through 12.11.3).

12.11.1 Advantages

This design is compact. The shorter arm length may increase load capacity with reduced moments. Robot arm may handle variable and complex movements. Maintenance is good from an access standpoint. Stowability is good.

12.11.2 Disadvantages

This design requires coordination with door openings and shelf mounting heights. Plants may be disrupted or damaged as the arm moves around the circumference. This design lacks 360° rotation due to doorways. It is costly to implement and difficult to expand to the lower chamber. Reliability is poor due to complexity.

12.11.3 Feasibility

This design has only a fair rating in feasibility because of the large amount of modification to the chamber that may be required and the lack of 360° rotation.

12.12 CEILING MOUNTED TRACK

Similar to center or low wall mounted tracks, this design uses the perimeter and roof of the chamber for support and a shortened robot arm (Figure 12.12.1).

12.12.1 Advantages

The ceiling mounted track design provides good reachability and strength. The track system should fit easily into the upper edges of the chamber without conflicting with grown plants. 360° rotation and short arm length provide good load capacity and low moments on the arm. Stowability is good.

12.12.2 Disadvantages

Modifications of the chamber may be extensive and costly. Stability is only fair. Installation is difficult. Maintenance is poor as robot and track are difficult to access. Reliability is poor because of the complexity.

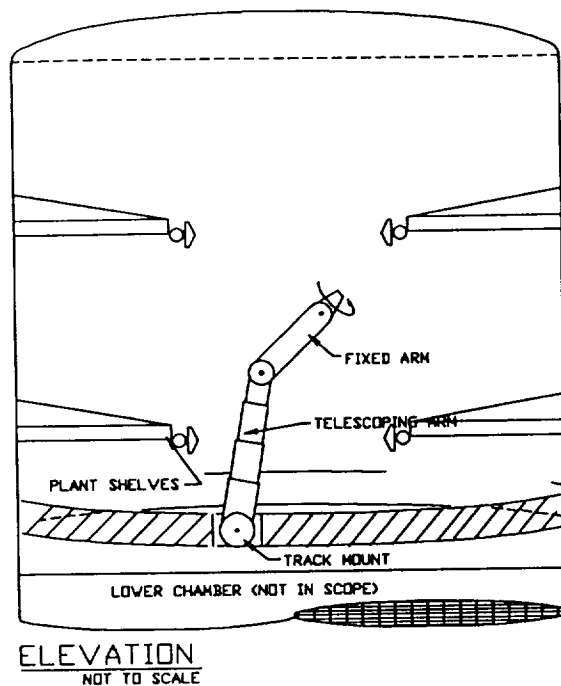

Figure 12.11.1 Low Wall Mounted Track, Hybrid Arm

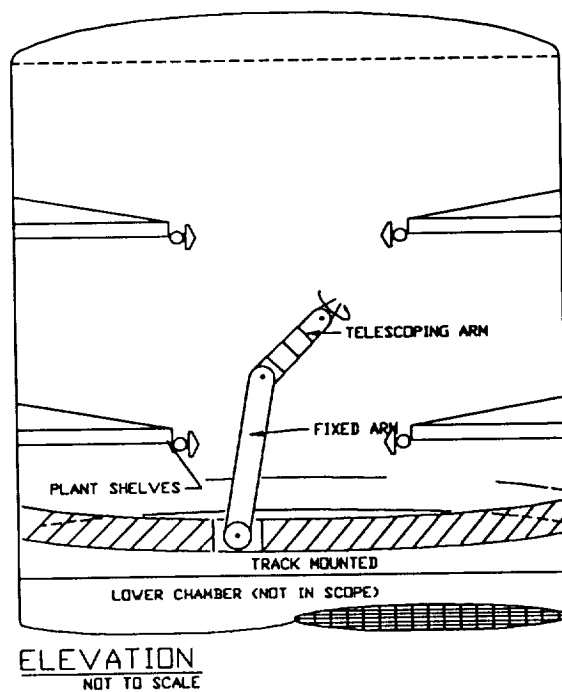

Figure 12.11.2 Low Wall Mounted Track, Hybrid Arm

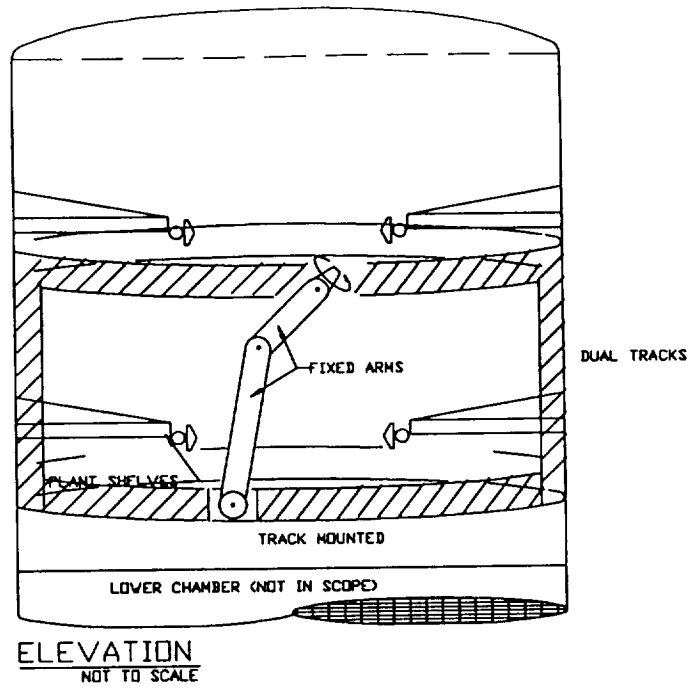

Figure 12.11.3 Low Wall Mounted Dual Track, Fixed Arms

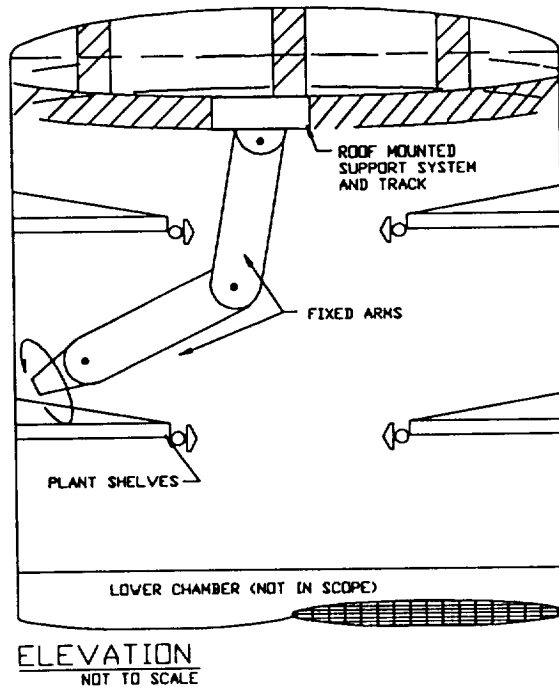

Figure 12.12.1 High Mounted Track, Fixed Arm

12.12.3 Feasibility

This design has good feasibility due to its ruggedness. The robot arm working from the perimeter may reduce stability. Extent of modifications also reduces the overall feasibility.

12.13 TOP CENTER MOUNTED PULLEY WITH MULTIPLE FIXED ARMS

Two center roof mounted pulleys with motors drive single loop chains which raise and lower the robot arm attachment (Figure 12.13.1). The robot arm rotates 360° and contains a counterweight which provides stability in the x-axis. The arm has a sliding actuator to provide extension to the perimeter.

12.13.1 Advantages

This design remains self-contained within the chamber. It provides good reachability, 360° rotation, short arm length and good stowability.

12.13.2 Disadvantages

The chain may foul with dust or other particulants. The design is inherently unstable due to lack of support in all axes. The design is gravity dependent and application is restricted. Maintenance is poor because the motion mechanism is located at the top of the chamber. Reliability is poor due to the complexity and number of moving parts. Control is difficult and complicated because pulley, motor and chain motion must be synchronous for balanced movement. Cost is high.

12.13.3 Feasibility

This design is not feasible due to instability and gravity dependence. Because of these same two factors, applications are too restrictive. Feasibility is also poor from a control and maintenance standpoint. Costs are high to install and operate.

Chapter 13.0 FINAL DESIGN

13.1 COORDINATION WITH OTHER GROUPS

Group Three was required to coordinate with Group Two to connect the telescopic arm to the vertical shaft. The following paragraphs explain how this is accomplished.

The telescopic arm is mounted to the turn-bearing. The turn-bearing is mounted to the vertical shaft. A rectangular plate is mounted to one side of the turn-bearing (Figure 13.1.1). The telescopic arm is bolted to the plate which will be bolted to the turn table. The bolts are installed from the internal section of link one.

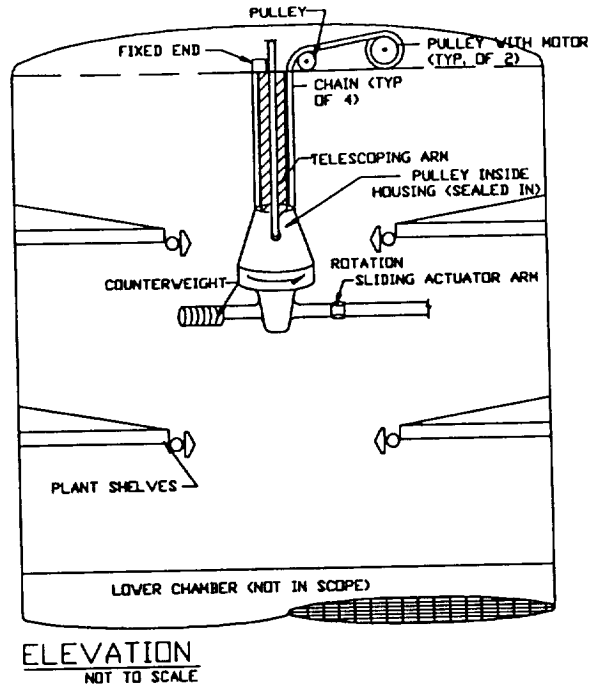

Figure 12.13.1 Top Center Mounted Pulley, Multiple Fixed Arms

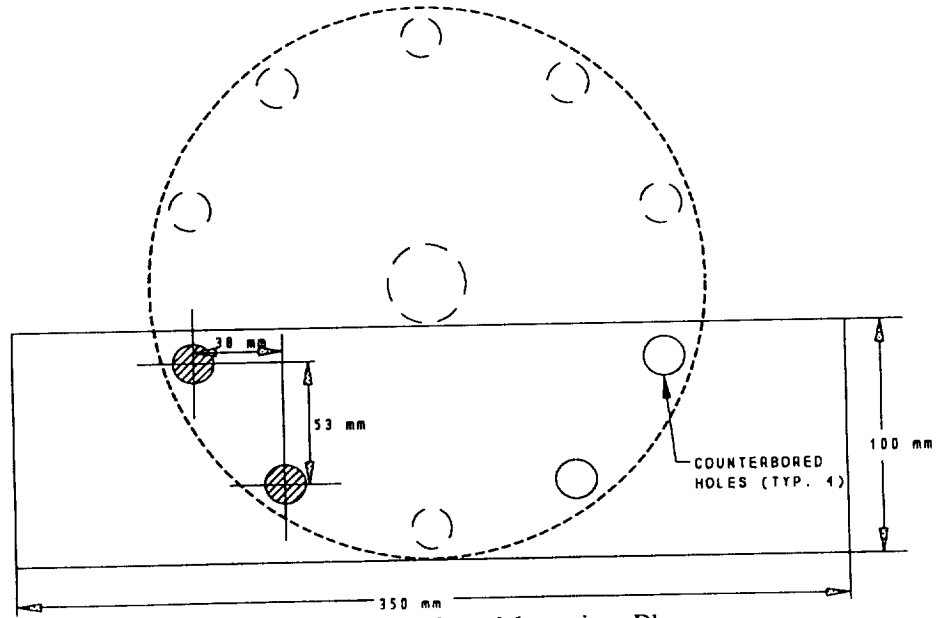

Figure 13.1.1 Interface Mounting Plate

The plate is mounted only to one side of the turn table. The bolts are pre-lubed and torqued to standard value during integration.

13.2 CRITICAL PARTS ANALYSIS

13.2.1 Work Envelope

The work envelope is a region in space which the robot mechanism can possibly occupy while performing different tasks. For clarity, the overall work envelope will be divided into two parts. The first is the volume swept out when the arm is in the retracted mode and the other is when the arm is in the full extension mode.

When the arm is retracted it must be capable of staying inside a vertical cylinder of 48.26 cm of radius. This distance is measured from the center of the CELSS chamber, and extends upward over the vertical length of travel provided by the ball screw mechanism (Figure 13.2.1.1). This will allow the arm to clear the shelves and plumbing while traversing up or down.

For the full extension mode of the arm the retracted work envelope must be extended an additional 136.74 cm (Figure 13.2.1.2). This will enable the arm to reach out to the wall of the CELSS unit. It should be noted that this work envelope includes the shelves and lights and that the controllers need to provide safety considerations to prevent property damage.

13.2.2 Telescopic Sections and Overlap

The arm is constructed of six, square, hollow, concentric tubes of aluminum with a wall thickness of 2 mm (Figure 13.2.2.1). Five of these tube sections are the same length, 50.8 cm, and slide into main casing of 71.12 cm in length by 16.48 cm width and height. The main casing provides a 20.32 cm length region for the Linear Actuator System while also accommodating the rest of the retracted arm. Each of the five successive extension section, all with a length of 50.8 cm, will reduce down in size to the final extension section with a width and height of 7.63 cm. The section which extends to the maximum position will remain extended 10.16 cm when in the fully retracted position to allow for the future attachment of an end effector.

Due to the restrictions created by the retracted work envelope an extension length of 30.48 cm was decided to be employed for each of the five extension sections. To provide counter measures for the moments produced by the payload and the weight of the arm, an overall section length of 50.8 cm was chosen. This results in an overlap of 20.32 cm. These values were determined by doing a static analysis of the forces and moments (Appendix G). Using these values, a model of a cantilever beam was created in ALGOR to determine the maximum deflection due to the maximum intended payload, (See Section 13.8). The analysis revealed that a deflection of 1.08 mm is to be

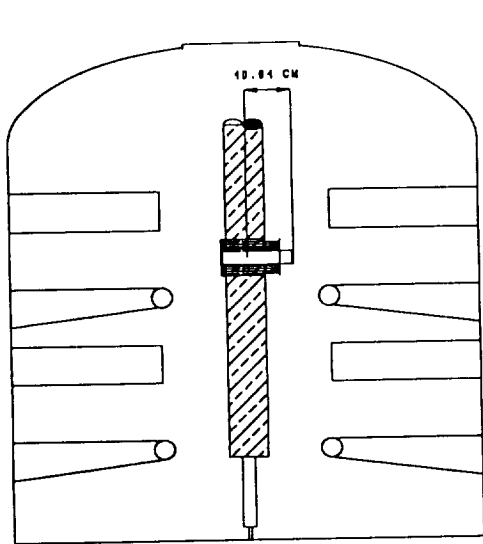

Figure 13.2.1.1 Retracted Telescopic Arm

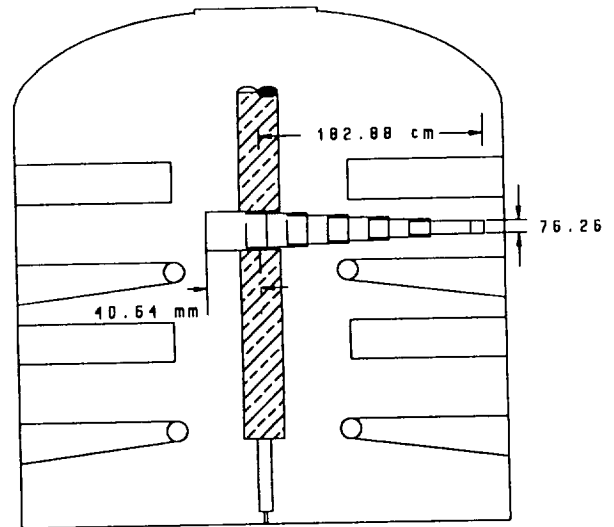

Figure 13.2.1.2 Extended Telescopic Arm

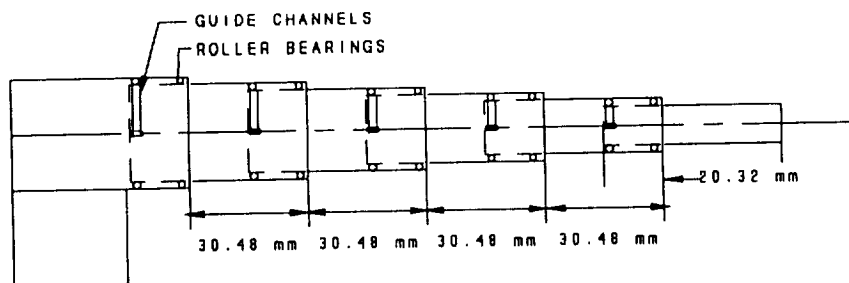

Figure 13.2.2.1 Telescoping Robot Arm

expected for the aluminum material alone. This value must be included in the summation of all the contributions from all three main components to a maximum allowable deflection of 6.35 mm at the end of the arm.

13.2.3 Rollers

To provide a smooth sliding action with minimum frictional resistance in a high humidity environment it was decided that a steel sealed needle bearing roller be used (Figure 13.2.3.1). When compared to self lubricating composite bearings, the friction coefficient of 0.0003 for the steel roller is far superior to the range of .05-.16 coefficient of friction for the composite bearing. The rollers are 6.35 mm in diameter and have a length of 10 mm (See Sections 13.7 and 13.8).

To reduce the point load on each roller and increase torsional stability, a minimum of four rollers should be used between any two adjacent planes in contact along the arm. To prevent an over extension or excess travel of any section, roller stops will be installed at the required positions. The stops used to prevent over extension in the payload direction are removable to allow for disassembly, inspection and maintenance of the interior components of the arm assembly.

13.2.4 Trip Mechanism

When the arm is extended it is desired that there be a successive order to the segments to be extended. To achieve this a pivoting arm held in contact with the arm segment provides a friction fit to prevent unwanted motion. Links two through five have their own trip mechanism. For example, when link one is extended by the actuator, it extends until its roller bearing hits the roller stopper attached to link two. Then link two extends and so on. Right before the roller stopper in link two, is the trip mechanism. Link two through five have a small square cut into each link, located immediately before its roller bearing, and the trip mechanism is attached to a pivot bar located in the square. The rubber tip presses against the next upper link.

For example, when the roller bearing from link one hits the trip mechanism that is part of link two, which is friction held to link three, the trip mechanism is forced to move off of the upper link and then link two is free to move. Since the trip mechanism is part of link two, it just rides with link two.

All this allows the telescopic arm to extend in order, but to achieve this during retraction, the same type of mechanism is placed in front of the inner wheels. (See Section 13.6).

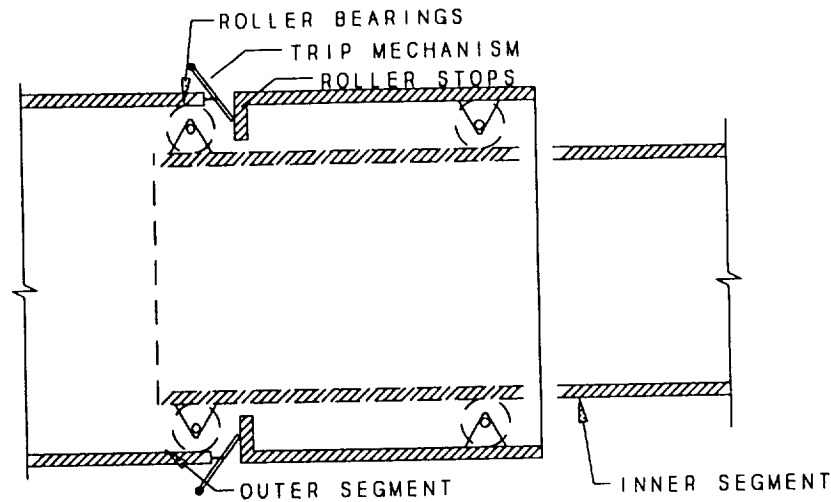

Figure 13.2.3.1 Roller Bearings

13.2.5 Load

The design requirements state that the arm have the capability to lift a 15 kg payload throughout the entire work envelope. This value has been used in determining the material and reaction force requirements to be achieved by the robotic arm. At first it was thought that an off the shelf item could be obtained from a robotics manufacturer. After contacting manufacturers in the United States and Canada, it was found this load requirement at full extension excludes the possibility of obtaining an existing model.

13.3 MATERIAL CONSIDERATION AND SELECTION

Aluminum alloy has been chosen to be the material for the telescopic arm due to its desired mechanical and physical properties. The alloys are narrowed down to three following choices of composition: 6061-0, 6061-T4 (T451), 6061-T6 (T651). Out of these three, 6061-T6 (T651) shall be selected to build the telescopic arm for the following reasons.

Alloy 6061-T6 (T651) is a general purpose material for building light but strong structures. This alloy is often used in building airplane parts. It is the easiest of the three to machine and the price difference is not considered significant. The alloy has one of the highest ultimate tensile strength and tensile yield strength of 45 ksi and 40

ksi respectively among the other aluminum alloys. This alloy also possesses one the highest hardness values. The ultimate shearing strength for this alloy is 30 ksi, which is higher than most aluminum alloys.

13.4 VENDOR SELECTION

The vendor selection was completed by using the Thomas Register to obtain vendor information for the current robotics industry. Representatives from robotics manufacturers were given information regarding the telescopic robot arm design. The design will not be an off the shelf item due to its unique parameters and dimensional requirements for the clearance in the CELSS chamber. Out of the many vendors selected and contacted by Group Three, very few were able or willing to custom manufacture the arm. These few were willing to discuss possible future manufacturing needs, provided they were given more detailed information about the design. The following are the companies contacted for the possible future manufacturing needs.

John Gibson, Vadeko International Inc. 2600 Argentia Rd., Mississauga, Ontario, Canada L5N 5V4.

Vadeko Voice Line: (416) 821-3222 Fax Line: (416) 821-2232

CRC Plus, 830 Harrington Court, Burlington, Ontario, Canada L7N3N4
Phone: (905) 639-0086 Fax Line: (905) 639-4248

The University of Central Florida campus machine shop was also contacted as a possible builder of the telescopic robot arm design. Although the past experience with the machine shop has been satisfactory, this task may exceed the shop's capability.

13.5 LINEAR ACTUATOR SYSTEM

13.5.1 Basic Design

The linear actuator system is responsible for the linear motion of the telescopic arm. The design is composed of a series of concentric ball screws which force the extension of the telescopic arm when rotated. The ball screws, gear box and motor are internally stored in a casing. There are four ball screws used in the design. Each have a length of 66.04 cm. A gearing box is used to translate the power of the motor into a rotational force which is applied to the smallest ball screw. The smallest ball screw (screw 1) is a solid shaft with the threading located on the outside of the shaft. A larger, hollow, ball screw (screw 2) with threads on the inside and outside of the shaft is threaded onto the smaller screw 1. Screw 3 is a larger version of screw 2 with threads on the inside and outside. Screw 3 is threaded onto screw 2. The largest ball screw (screw 4) is hollow, however, it only has threads on the inside. Screw 4 is threaded onto screw 3. The threading on each of the ball screws, both inside and outside, stops 7.62 cm. away from each end. When the linear actuator system is fully extended, there is a 15.24 cm

overlap at each end of the screws, because the threads stop. This full extension for a reach of 228.6 cm when the ball screws and the gear box are included. The required reach for the telescopic arm is 223.52 cm, so the linear actuator system provides the necessary length for the full extension of the telescopic arm.

13.5.2 Gear Box and Motor

The gear box is used to convey power from the motor into torque required for extension of the linear actuator system. The gear box has a space of 10.16 cm in the direction the telescopic arm extends and a cross-section of 40.64 cm by 40.64 cm. A similar design which uses only two screws is commercially available. The commercially available system is capable of pushing 454.54 kg. The gear box for the commercially available system is small enough to fit into the space provided for the gear box for this design. The motor for the commercially available linear actuator is also small enough to fit into the largest section of this telescopic arm. If the motor takes up too much space within the design telescopic arm, it may be alternately mounted on the outside of the arm. The requirements for the motor are to be determined.

13.5.3 Actuation System

The linear actuation system extends itself to a length of 228.6 cm through the use of four concentric ball screws. Screw 1 is fixed in position with the gear box and is rotated along its longitudinal axis. This rotation causes screw 2 and screw 3 to also rotate. Screw 2 and screw 3 do not actually extend themselves because there is no force to keep them in place. This is similar to turning a bolt with a nut on the end. When the bolt is turned, the nut also turns with it until a force is used to keep the nut in place. Once this force is used, the nut begins to move down the bolt. Screw 4 has a force applied to it by two screw stoppers which are located on the inside of the actuator casing near the end. These screw stoppers have a spring in them which causes the stoppers to apply pressure to the exterior screw and stop its motion. This allows the mechanism to lengthen, since screw 4 is becoming extended with respect to the combination of screw 1, screw 2 and screw 3. Screw 4 lengthens itself with respect to the actuator until it reaches the end of the threads, which is 15.24 cm from the end. Screw 4 becomes locked into place at this time. This coincides with the screw stoppers sliding off of screw 4 and onto screw 3. The end of each screw is tapered so that there is a smooth transition for the screw stoppers, from the larger screw to the smaller screw. This will allow the springs in the two stoppers to extend themselves so that the screw stoppers remain in contact with a ball screw at all times. This tapering also allows the process of retracting the telescopic arm to function smoothly. The screw stopper springs are forced to contract when going from a smaller to a larger diameter screw. Screw 3 then follows the same process as screw 4. Once screw 3 has been fully extended, the process is repeated for screw 2. When all three screws have been extended, the telescopic arm has reached the wall of the CELSS chamber.

13.6 TRIP MECHANISM

The trip mechanism enables the arm to extend one segment at a time. It consists of a pivoting arm on a spool with a round rubber end piece (Figure 13.6.1). In its holding position, it uses a friction fit to hold the middle arm stationary against the outer arm, while the inner arm slides out. When the inner arm is fully extended, one roller on the top and one on the bottom trip the pivoting arms out of their holding positions and allow the middle arm to begin movement. When the telescoping arm retracts, the pivot arms are placed into their friction fit and holding positions by the motor power retracting the linear actuator.

13.7 TELESCOPIC ARM ROLLERS AND BEARINGS

Rollers are used mainly for guidance of inner telescopic members along and through outer telescopic members (Figure 13.2.3.1). The rollers on the top and bottom of the members are also used to counter the forces and moments developed at the reducing joints.

Friction characteristics must be considered because of the large number of contact points between the rollers and the aluminum square tubes. Typically, the coefficient of friction between aluminum and aluminum, in a full surface contact, is 1.05 for static friction and 1.4 for sliding friction.^{20a} These values emphasize the need for rollers. A reduction in friction coefficients is directly related to a reduction in motor power to extend and retract the linear actuator. Calculations for rolling friction (See Appendix H)^{20b} show that the coefficient of friction may be reduced to 0.0053.

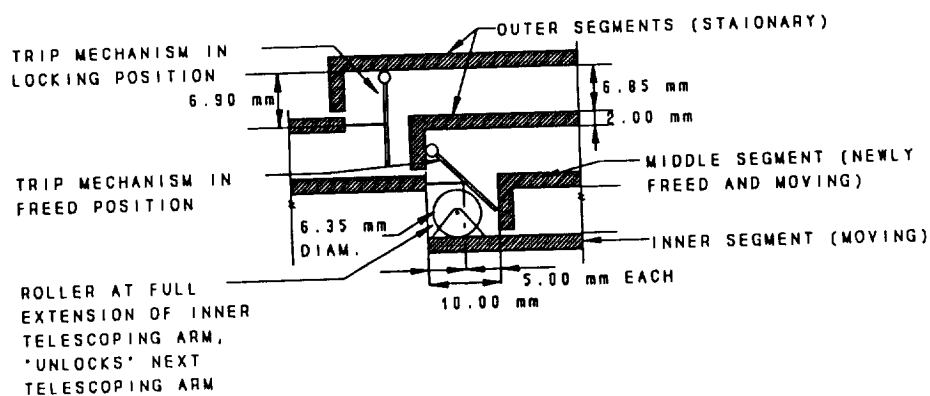

Figure 13.6.1 Trip Mechanism

13.8 STATIC AND KINEMATIC ANALYSIS

13.8.1 Preliminary Analysis

Initially, Static and Partial Kinematic analysis was performed on the telescopic robot arm design using the payload weight of 15 kg. Telescoping pieces were modelled as round, hollow aluminum members for ease of calculations. The largest outer diameter used was 20 cm. and the smallest outer diameter used was 15 cm. Wall thickness was taken as 4 mm. Using basic Shear and Moment Diagrams and modelling the robot arm as a cantilever beam (Appendix I). The maximum shear loads occur at the base of the robot arm. The maximum moments also occur at the base of the robot arm. Data is listed in Table 13.8.1.1.

TABLE 13.8.1.1 Maximum Shear Forces and Moments

Maximum Shear Force (N)	242.25
Maximum Moment (N-m)	293.20

Appendix J contains the rationale to justify using a rectangular beam instead of the circular cylinder used for the model.

13.8.2 Final Analysis - Downsized Arm

Static and Kinematic Analyses from the 60% design phase were refined to streamline the dimensions and shape of the robot arm telescoping elements.

First, the arm dimensions were reduced to a point at which deflection values fell at or below the acceptable values. Second, the geometric parameters of the arm were minimized. Aluminum is the material of construction. Dimensions of the arm at the ball screw interface are 164.8 mm square, with a 2 mm thick wall. Dimensions of the arm at the end effector are 76.3 mm square, with a 2 mm thick wall. Values are summarized in Table 13.8.2.1. Elements are numbered from smallest to largest.

TABLE 13.8.2.1 - Deflection and Geometric Parameters

Element	1	2	3	4	5	6
Deflection (mm)	1.08	-	-	-	-	-
Area (mm ²)	594	736	878	1019	1160	1302
Mom. of Iner. (mm ⁴)	5.5E4	1.1E5	1.8E6	2.8E6	4.1E6	5.8E6
Sect. Mod. (mm ³)	1.1E4	1.7E4	2.4E4	3.2E4	4.2E4	5.3E4
Tors. Resist. (mm ⁴)	5.6E5	8.6E5	1.2E6	1.6E6	2.1E6	2.7E6

Length (mm)	305	305	305	305	305	458
Weight (kg)	0.561	0.694	0.828	0.961	1.095	1.843

Maximum deflection occurs at the end effector. Due to the three component nature of the robot design and maximum allowable deflection of 6.35 mm, deflection per component is estimated at one third of the total deflection allowed. Deflection contributions from the arm, incorporating a factor of safety of 2, is 2.168 mm. This is within 3% of the estimated amount allowed.

Third, the maximum Shear Forces and Moments are reevaluated based on the reduced arm weight. Values are summarized in Table 13.8.2.2.

TABLE 13.8.2.2 - Maximum Shear Forces and Moments

Maximum Shear Force (N)	255
Maximum Moment (N-m)	297

From the 60% preliminary design phase, the maximum load per roller was calculated to be 792 N. The design roller bearings have a 6.35 mm outer diameter, 1.59 mm inner diameter, six rolling elements with 1.79 mm diameter each, a length of 10 mm and are constructed of normal ball bearing steel material. The allowable load per roller bearing is calculated as 1095 N. For supporting calculations, see Appendix K^{18c}. Actual roller bearings may not have these exact characteristics, but shall be equivalent.

Because aluminum is much softer than steel, the arm element / roller bearing interface require close scrutiny. To prevent wear patterns or tracks in the arm element, steel strips shall be resistance-tack welded to the arm, along the roller bearing pathway. This method of welding is acceptable for this application as it will not contribute to deformation of the aluminum in the weld process^{20b}. The steel strips will preserve the integrity of the aluminum arm, avoid the addition of substantial amounts of weight that would occur if the arms were made entirely of steel, avoid costly surface hardening treatments for the aluminum and improve the sliding and rolling resistance coefficient with a steel-to-steel interface. The coefficient of friction is 0.0003^{18d}.

13.9 DYNAMIC ANALYSIS

For the dynamic analysis the telescopic robot arm is modeled as a square hollow beam with lumped masses. To simplify analysis the telescopic robot arm cross sectional area is approximated as a constant. The total weight of the telescopic arm is 6 kilograms, and the weight at the end effector of the payload is 15 kilograms. The parameters, set by the CELSS Group Two, for angular velocity and acceleration were 0.08 RPM.

$$\omega = \frac{2 * \pi * N}{60 * t}$$

N= Change in angular velocity t=time

The vertical velocity is 9 m/min. The acceleration to reach this speed was not determined but it will be small.

For the angular rotation the maximum velocity and acceleration occurs at the end of the arm. At the end of the arm the velocity is 92.0 cm/min. and the tangential acceleration is .256 mm/s². This extremely small velocity and acceleration produce a negligible inertia force of .00460 N. This inertial force produces a deflection in the tangential direction of only .0176 mm, which is negligible compared with the 1.1 mm deflection produced by gravity.

For the vertical motion of the arm, the acceleration has not been determined but it is also very small. In order for the robot arm to move vertically, it must be in the closed position otherwise it will hit the shelves. Regardless of the acceleration required to reach 15 cm/min. there is not a significant difference in dynamic deflection from the static deflection because the robot arm must be in the closed position. In the closed position the robot arm is basically inelastic and experiences a very small moment.

Because the support for the telescopic arm was designed for extremely low velocities and accelerations, the dynamic deflections and vibrations can be neglected. If higher velocities and accelerations are required these calculations must be reevaluated.

Chapter 14.0 OBSERVATIONS AND RECOMMENDATIONS

The purpose of this subsystem is to provide horizontal positioning of the end effector with respect to the center of the CELSS chamber. The three primary considerations for this design were:

1. Arm manipulation with a 15 kg. payload end effector.
2. Minimizing the weight of the subsystem.
3. Maximizing the use of commercially available parts.

The design goals for this subsystem were accomplished by using a six segment telescopic arm with rectangular cross sections and an electro-mechanical linear actuator system. Efforts to locate a commercially available telescopic arm system were unsuccessful. All segments of the telescopic arm system will require fabrication from 6061 T-4 aluminum.

The roller bearings and bearing track assemblies are commercially available. No special fabrication or modifications to these assemblies should be required. The extension trip mechanism is complex and of unique design. The complexity of the mechanism and required maintenance during the life cycle are an unfavorable component of the telescopic arm design. The design group is continuing to explore more feasible alternatives for this system.

The linear actuator system chosen for the telescopic arm may require modification to allow the system to meet the required full extension length of 183 cm. Consultation with the manufacturer has led to the conclusion that procuring a modified linear actuator system may be economically undesirable. The design group is currently consulting with other vendors in an effort to locate an actuator that will allow full extension of the telescopic arm without requiring modification.

The arm interface plate will require fabrication. The simplicity of this part should not require any special fabrication techniques. At the time of this report, arm attachment to the interface plate is still an issue. Original designs required the arm to be welded to the interface plate. This design facet may be changed to allow attachment with a removable fastener system. This would enhance the maintenance access to internal telescopic arm components. During the design phase Group three had two concerns with the design of the telescopic arm.

Chapter 15.0 ACKNOWLEDGEMENTS

We would like to gratefully acknowledge the support and confidence bestowed upon us by Mr. Gabor Tamasi and Mr. Bill Martin of the National Aeronautical and Space Administration. We would also like to thank Mr. Russ E. Fortson; Agricultural Engineer, Bionetic Corporation; for the help and guidance with the project.

Other contributors to this project whom we would like to acknowledge are Dr. A. H. Hagedoorn, and Dr. F. A. Moslehy all of the University of Central Florida Mechanical and Aerospace Engineering Department, and Dr. W. S. Byers of the University of Central Florida Electronic Engineering Technology Department.

SECTION IV

CONSTRUCTION OF
TELESCOPIC ARM

CONSTRUCTION

- * MATERIALS
- * ADHESIVES
- * SLIDER BEARINGS
- * ACTUATOR
- * MODEL STAND
- * AESTHETICS

SCHEDULING

- * LOGIC CHART
- * GANTT CHART

Chapter 16.0 CONSTRUCTION

16.1 MATERIALS

The materials search for the model boom arm consisted of many factors. These considerations were: strength and rigidity, weight, cost, accessibility, ability and ease to work with the tools at our disposal, transparency and bonding characteristics. The materials that met our preliminary criterion were: polycarbonate (Lexan), polyamide (Nylon 6/6), polymethyl-methacrylate (Plexiglas G) and polyacrylonitrile-butadiene-styrene (ABS).

16.1.1 Strength

The Lexan and Nylon have the greatest strength in this material comparison. They have a tensile strength in the range of 9000 - 12000 psi. The Plexiglas has the lowest strength of 3,000 psi.

16.1.2 Rigidity

The modulus of elasticity for the materials chosen range from 340-700 psi with ABS and Lexan being the most flexible and Nylon the most rigid. This is an important characteristic of the material to be used. It would not be desirable to choose a material that would cause a noticeable amount of deflection, however, the material must be flexible enough to allow ease of construction and elimination of unwanted brittleness.

16.1.3 Weight

Densities of the materials are as follows:

ABS	1.05-1.07 g/cm ³
Plexiglas	1.07-1.10 g/cm ³
Lexan	1.20 g/cm ³
Nylon	1.13-1.15 g/cm ³

16.1.4 Cost

The cost per pound of plastic is approximately:

Plexiglas	\$1.17
ABS	\$1.54
Lexan	\$2.42
Nylon	\$3.65

16.1.5 Accessibility

All of the materials listed are readily accessible. The Nylon is more difficult to find, but the Lexan and Plexiglas are easy to find locally.

16.1.6 Transparency

All materials listed are either transparent in their natural form or copolymerized to improve transparency. The polycarbonate is more amorphous in its true form making it slightly more transparent than the other plastics listed.

16.1.7 Conclusion

These materials all have the important characteristics needed to build the robot arm. However, after comparing the plastics, Lexan was chosen. This material gives the best rigidity and transparency. These two characteristics were the critical factors. This material is easy to work with which also was a factor. Finally, this material is accessible at a relatively low cost.

16.1.8 Material Selection

The trade name for the polycarbonate is Lexan 9034 (clear). This material was obtained from Commercial Plastics and Supply Corporation in a half sheets of 5 x 4 ft., and our desired thickness of 1/4 in. Design requirements were a minimum of 14.2 ft.² at a cost of approximately \$100.00.

Materials were not available in metric dimensions so all components were bought using English measurement units.

16.1.9 Building Plan

16.1.9.1 Special order Lexan 9034 - 112 (clear) 5 x 4 ft. sheet from Commercial Plastics and Supply Corporation in Orlando, FL (407) 293-5500.

16.1.9.2 Obtain material, Lexan, from supply house.

16.1.9.3 Make sure protective paper is kept on both sides.

16.1.9.4 Obtain technical drawings of link surface areas for model (Figure 16.1.9.4.1).

16.1.9.5 Draw surface area of each link on protective paper using a fine tipped permanent marker and straight-edged ruler. Arrange like Figure 16.1.9.4.1 leaving 1/8 inch clearance between each link for blade cut width.

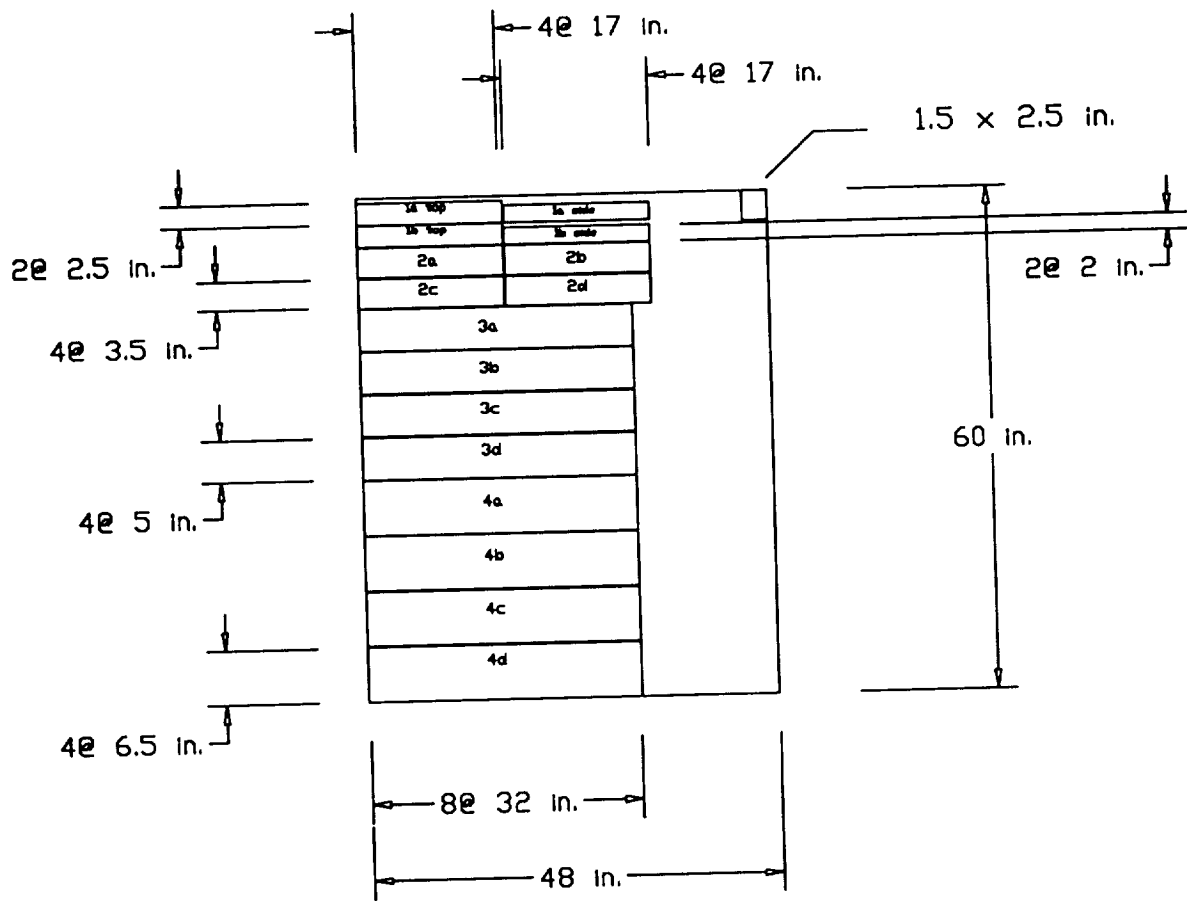

Figure 16.1.9.4.1 Lexan Sheet

- 16.1.9.6 Obtain hand circular saw and a 70 tooth 8 in. carbide tipped blade, or a less expensive alternative such as a plywood finishing blade.
- 16.1.9.7 Obtain a 5 x 4 ft. x 1/2 in. or larger piece of plywood.
- 16.1.9.8 Lay plywood on flat surface with Lexan on top.
- 16.1.9.9 Set blade cutting depth to 1/2 in.
- 16.1.9.10 If necessary tape a straight-edge to the protective covering. This can be used as a guide for the saw carriage.
- 16.1.9.11 Make cut between 3a and 2c-2d continuing across full 48 in. width (Figure 16.1.9.4.1).
- 16.1.9.12 Make cut along right hand sides of 4d through 3a. This should leave a large section of unused Lexan.
- 16.1.9.13 Make longitudinal cuts to separate each side for links 3 and 4.
- 16.1.9.14 Make cut from right hand side of 2d through the top of the Lexan.
- 16.1.9.15 Cut from right hand side of 2c through the top of the Lexan.
- 16.1.9.16 Make cuts to separate each of the existing sides of links 1 and 2.
- 16.1.9.17 Cut out end cap for link 1 (Upper right hand corner of Figure 16.1.9.4.1).
- 16.1.9.18 Check each link for correct dimensions.
- 16.1.9.19 If any dimensions are larger than indicated use a hand file or belt sander to make necessary corrections.
- 16.1.9.20 Sand all edges with 100 grit sand paper to eliminate burs.
- 16.1.9.21 Finish sand with 320 grit sandpaper until a smooth finish is formed.

16.2 ADHESIVES

16.2.1 Polycarbonate Cement SC-325

Polycarbonate cement SC-325 was selected as the adhesive to assemble the Lexan robot arm components. SC-325 is manufactured by Caseway Industrial Products. It is a solvent cement for bonding polycarbonate to itself and to some dissimilar materials. The solvent sets in seconds; however, it takes two weeks for optimum

curing. The SC-325 has been tested at 5000 psi after two weeks of curing time. Polyzap and CA glue are alternate adhesives. CA glue was not selected because of its tendency to "fog" the Lexan. A transparent model is necessary to view the internal components at work.

16.2.2 Cost

The cost for an 8 ounce container of SC-325 is \$6.75. Polyzap is only sold in .5 ounce tubes at a cost of approximately \$12.00 per ounce.

16.2.3 Availability

Polycarbonate Cement SC-325 is available at Commercial Plastics in Orlando. Polyzap is available and may be purchased at most hobby stores. It is sold locally at Central Florida Hobbies on the corner of Colonial and Kirkman.

16.2.4 Assembly of the Arm Components

16.2.4.1 Cut two (2) pieces of 1/2 in. thick plywood measuring 26 x 5 in. Refer Figure 16.2.4.1.1 for steps 16.2.4.1 through 16.2.4.1.6.

16.2.4.2 Label the pieces A and B.

16.2.4.3 Cut one (1) piece of 1/2 in. plywood measuring 26 x 12 in.

16.2.4.4 Label this piece C.

16.2.4.5 Cut one (1) piece of 1/2 in. plywood measuring 12 X 5 in.

16.2.4.6 Label this piece D.

16.2.4.7 Place (4) 1/2 in. wide x 1/4 in. deep router grooves in piece C, parallel to the long edge of piece C extending the full length of piece C, at the following distances from the left edge of piece C. Refer to Figure 16.2.4.7.1 for steps 16.2.4.7 through 16.2.4.14:

- 2 in. from left side, label as a
- 3 in. from left side, label as b
- 4.24 in. from left side, label as c
- 6.40 in. from left side, label as d

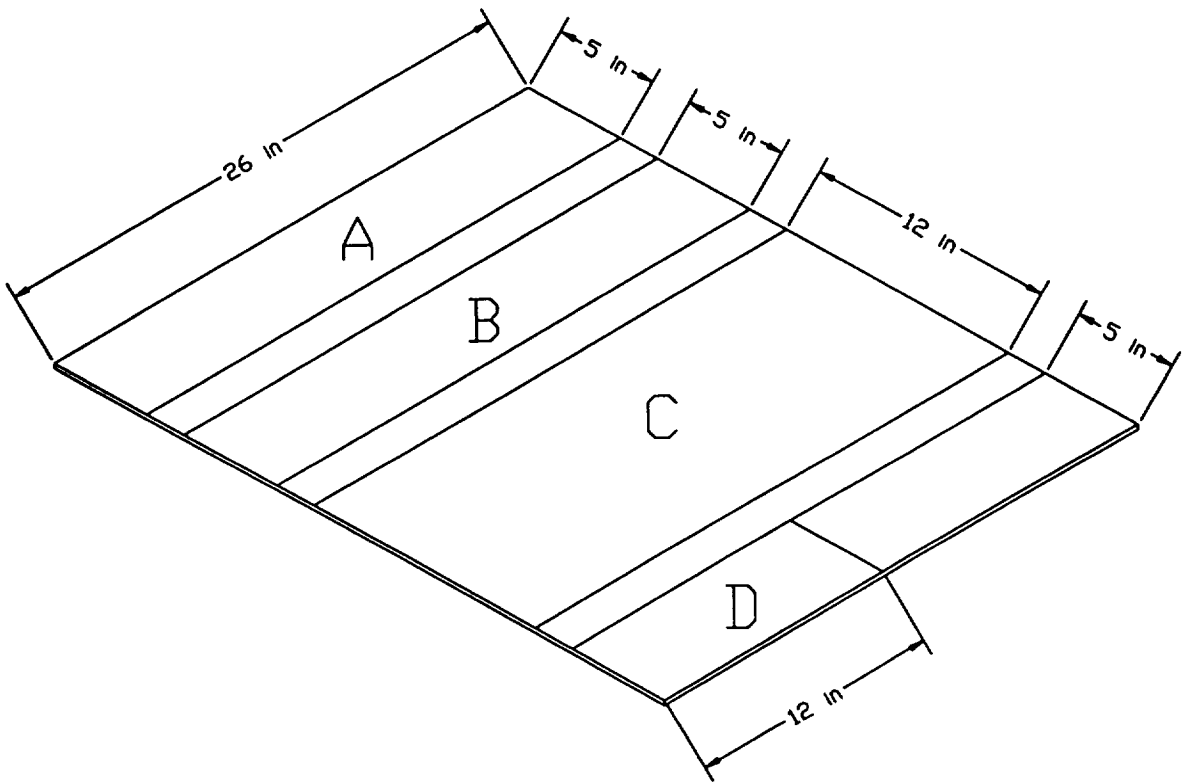
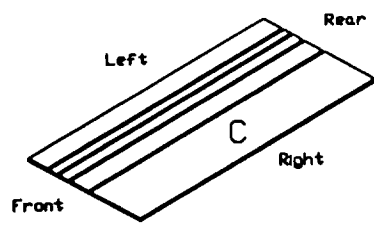
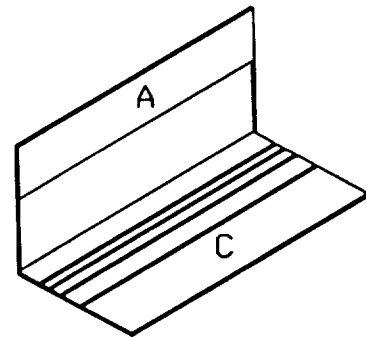

Figure 16.2.4.1.1 Plywood Cuts

1)



2)



3)

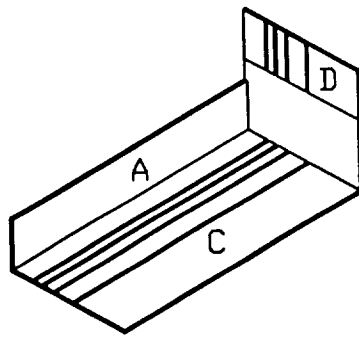

4)

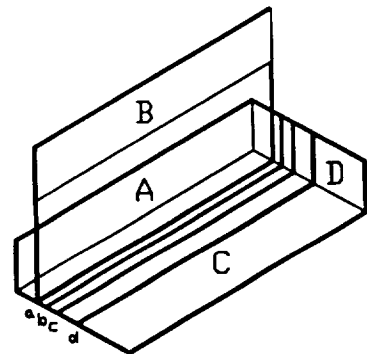

Figure 1.2.4.7.1 Construction of Jig

16.2.4.8 In piece D place (4) 1/2 in. wide x 1/2 in. deep router grooves, parallel to 5 in. edge extending the full height of the edge, at the following distances from the left edge of piece D:

2.25 in. from left side, label as a

3.25 in. from left side, label as b

4.49 in. from left side, label as c

6.40 in. from left side, label as d

16.2.4.9 Lay piece C on floor.

16.2.4.10 Stand piece A on its side on the floor parallel to left side of piece C.

16.2.4.11 Nail pieces A and C together and secure with wood glue.

16.2.4.12 Stand piece D on its 12 in. edge and line up with rear sides of pieces A and C.

16.2.4.13 Nail piece D to pieces A and C and secure with wood glue, to form a three sided box.

16.2.4.14 Place long edge of piece B in groove a of piece C.

16.2.4.15 Lay piece a1W of Lexan lengthwise inside of wooden frame and on top of piece C, and flush against piece D. Refer to figure 16.2.4.15.1 for steps 16.2.4.15 through 16.2.4.31.

16.2.4.16 Place piece a1H of Lexan lengthwise inside of wooden frame and with edges flat against pieces A and D.

16.2.4.17 Hold pieces a1H and a1W flat and flush with each other.

16.2.4.18 Take Polyzap glue and run a bead along inside corner of piece a1H and a1W.

16.2.4.19 Place piece a2H of Lexan lengthwise inside of wooden frame and with edges flat against pieces B and D.

16.2.4.20 Hold pieces a2H and a1W flat and flush with each other.

16.2.4.21 Take Polyzap glue and run a bead along inside corner of piece a2H and a1W.

16.2.4.22 Remove three (3) sided Lexan box from jig.

16.2.4.23 Install bearings per section 1.3.

16.2.4.24 Lay piece a2W horizontally and lengthwise on top of pieces a1H and a2H and with.

1)

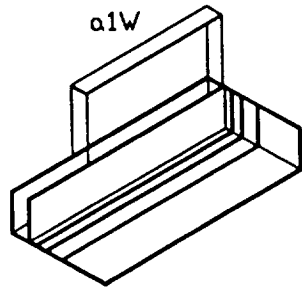

2)

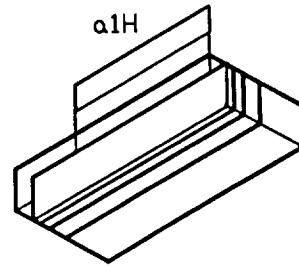

3)

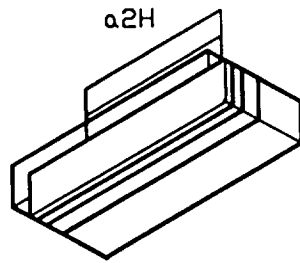

4)

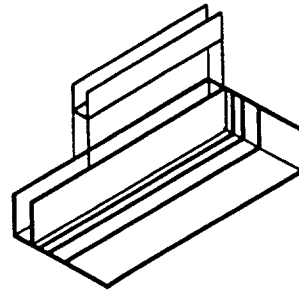

5)

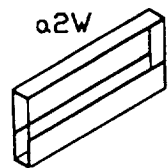

6)

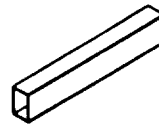

Figure 16.2.4.15.1 Construction of Arm Links

- 16.2.4.25 Line up corners of piece a2W with corners of three sided Lexan box.
- 16.2.4.26 With a small amount of Polyzap tack the corners of piece a2W to the corners of the three sided box.
- 16.2.4.27 Make sure that piece a2W is lined up correctly.
- 16.2.4.28 Take Polyzap glue and run a bead along the inside corners of pieces a2H and a1W.
- 16.2.4.29 Stand Lexan box on end.
- 16.2.4.30 Take Polyzap glue and run a bead along all four outside edges of Lexan box.
- 16.2.4.31 Repeat steps 16.2.4.15 through 16.2.4.30 for sections 2 through 4 of the arm.

16.3 SLIDER BEARINGS

To facilitate a smooth action between the telescoping sections of the model arm, a cabinet drawer slide, model number 1284 WH manufactured by the Knape and Vogt MFG. Co. of Grand Rapids, Michigan was selected. These slider bearings are rated for 445 N capacity and should work well for modeling purposes. For the 33 cm extension sections, the 450 mm length was chosen and can be used without modification. However, for the 66 cm extension section two sets of the 610 mm length will have to be sectioned and made to fit this section.

For ease of installation and clarity, a nomenclature will be established for the parts to be assembled. The end of each section which will be closest to the payload end shall be considered the front, while the end closest to the ball screw and shaft shall be called the rear. While assembling only consider the interface between two adjacent telescopic sections at one time. From now on the section that will fit inside the next larger section will be called the male section while the larger section shall be called the female section. Also, the slider bearing which attaches to the male section shall be called the male slider member and the slider bearing which attaches to the female section shall be called the female slider member.

16.3.1 Slider Bearings Installation

- 16.3.1.1 Determine the right hand female slider member from the left hand male slider member by locating the stamped "CR" or "CL" on the slide members, respectively.
- 16.3.1.2 Determine the right hand male slider member from the left hand male slider member by locating the stamped "DR" or "DL" on the slide members, respectively.

- 16.3.1.3 Align male slider members to the outside bottom of the male section, flush with the front of the male section with the rollers located at the rear (Figure 16.3.1.3.1).
- 16.3.1.4 Drill a hole for the screws through the vertically oriented side slots using a 7/64 in. drill bit.
- 16.3.1.5 Fasten male slider member to male section using No. 6 x 7/16 in. flat head screws.
- 16.3.1.6 Drill and fasten with remaining screws as indicated above, but use the horizontal or circular slots, for a total of four screws per member.
- 16.3.1.7 Rest female slider member inside on the bottom of the female section with the roller end to the front and flush with the front end of the female section (Figure 16.3.1.7.1).
- 16.3.1.8 Repeat steps 4, 5 and 6 for female slider members.
- 16.3.1.9 File down all protruding screw ends with a metal file or grinder.
- 16.3.1.10 Insert male members by guiding male slider member rollers over female slider member rollers and insert male section into female section. To remove, extend male section to locked out position, then lift and pull.

16.4 ACTUATOR

The following nomenclature will be used in the assembly procedure of the actuator and its components. The end of each section which will be closest to the end effector will be considered the front, while the end closest to the ball-screw shaft shall be called the rear. In consideration of the links, the link that will fit inside of the next larger one will be called male, while the larger will be called the female section. The term outer shall be considered the outside surface area of the specified link, while the term inner shall mean the inside area of the specified link.

16.4.1 Actuator Arm Extension

- 16.4.1.1 Cut main body actuators 1-5 to specified length using an imp saw (Figure 16.4.1.1.1).
- 16.4.1.2 Cut interconnect tubing (Parts 1a - 4a; 2b - 5b; 1c - 4c) using an imp saw to 1/8(.125) in.
- 16.4.1.3 Attach 4a to outer rear end of tube 4 using JB Weld.
- 16.4.1.4 Attach 3a to outer rear end of tube 3 using JB Weld.
- 16.4.1.5 Attach 2a to outer rear end of tube 2 using JB Weld.

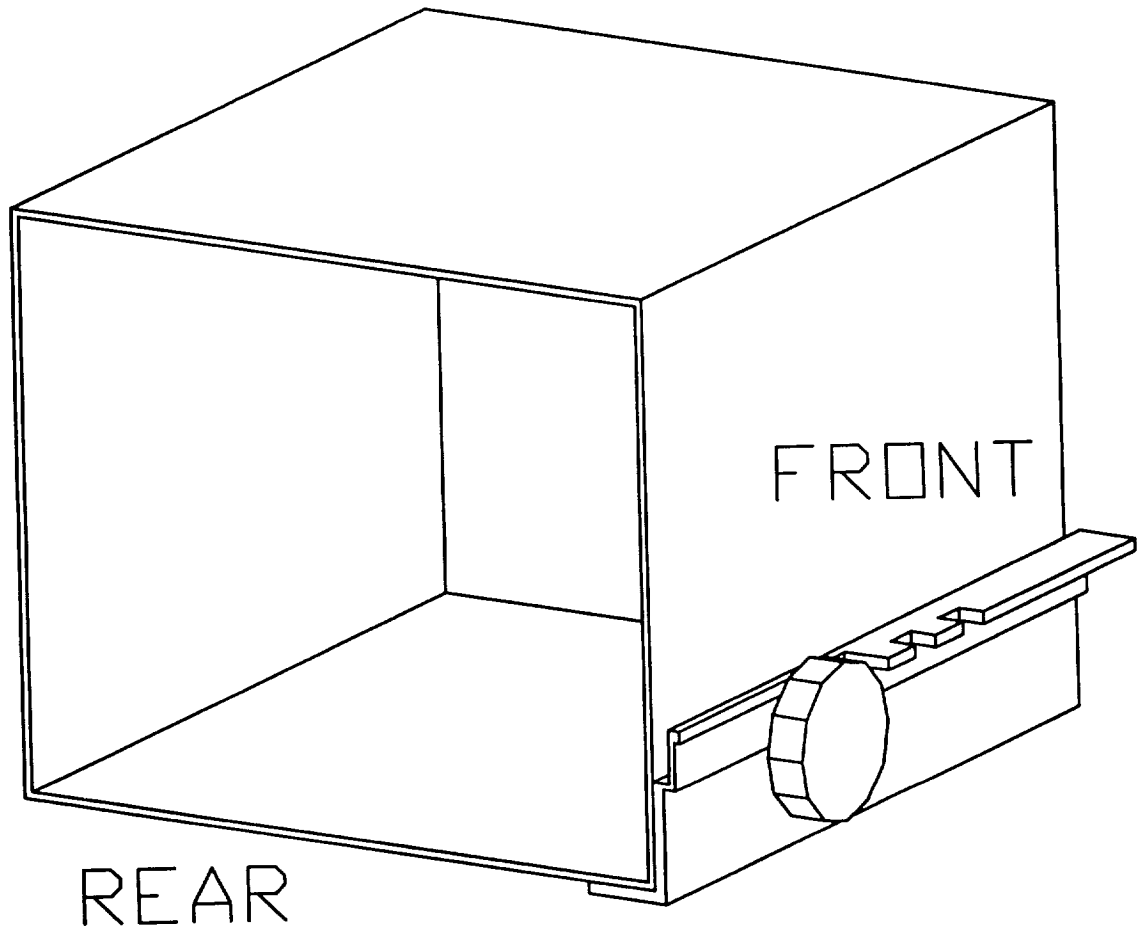

Figure 16.3.1.3.1 Male Member

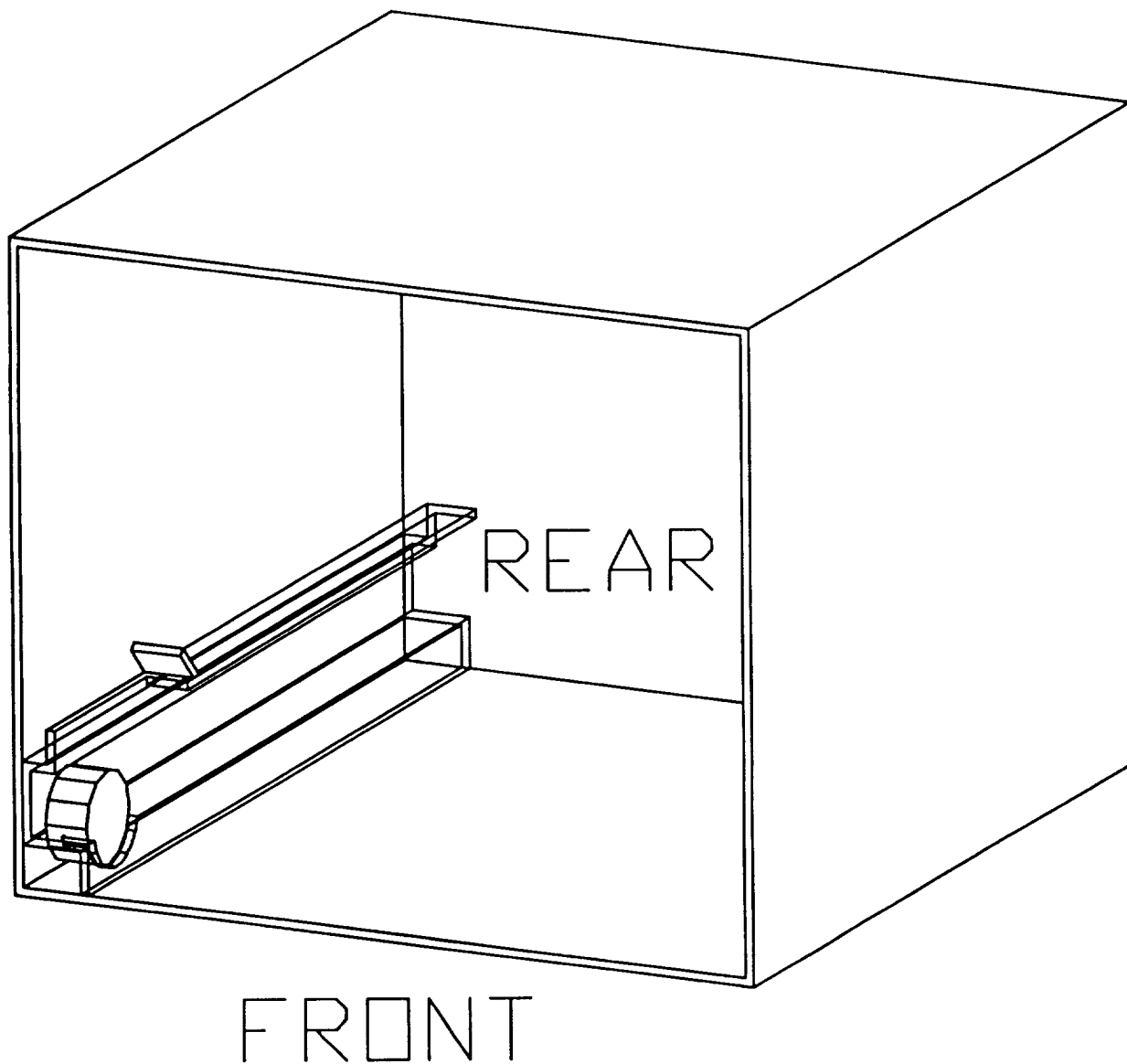
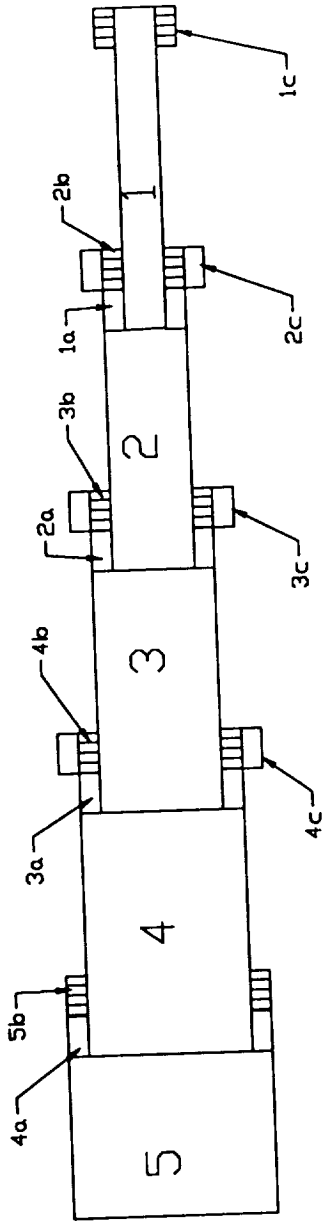

Figure 16.3.1.7.1 Female Member



drawing not to scale

Figure 16.4.1.1.1 Actuator Arm Extension

- 16.4.1.6 Attach 1a to outer rear end of tube 1 using JB Weld.
- 16.4.1.7 Attach 5b to inner front end of tube 5 using JB Weld.
- 16.4.1.8 Attach 4b to inner front end of tube 4 using JB Weld.
- 16.4.1.9 Attach 3b to inner front end of tube 3 using JB Weld.
- 16.4.1.10 Attach 2b to inner front end of tube 2 using JB Weld.
- 16.4.1.11 Insert actuator cable into inner rear of link 1.
- 16.4.1.12 Feed cable to inner front of link 1.
- 16.4.1.13 Screw a 5/32 (.15625) in. screw into front inner end of link 1 until the threads are no longer seen.
- 16.4.1.14 Insert front male end of link 1 into rear female end of link 2.
- 16.4.1.15 Insert front male end of link 2 into rear female end of link 3.
- 16.4.1.16 Insert front male end of link 3 into rear female end of link 4.
- 16.4.1.17 Insert front male end of link 4 into rear female end of link 5.
- 16.4.1.18 Attach outer retention ring 4c to outer front of link 4 using JB Weld.
- 16.4.1.19 Attach outer retention ring 3c to outer front of link 3 using JB Weld.
- 16.4.1.20 Attach outer retention ring 2c to outer front of link 2 using JB Weld.
- 16.4.1.21 Attach outer retention ring 1c to outer front of link 1 using JB Weld.
- 16.4.2 Mounting Bracket
 - 16.4.2.1 Using a Lexan block with dimensions 1 x 3/8 x 1/4 in. (1.00 x .375 x .25), drill a 7/32 (.21875) in. hole through the block using a standard steel drill bit.
 - 16.4.2.2 Drill one 1/8 (.125) in. bolt hole 1/8 (.125) in. over and 1/8 (.125) in. in from the corner (Figure 16.4.2.2.1).
 - 16.4.2.3 Drill one 1/8 (.125) in. bolt hole 1/8 (.125) in. over and 1/8 (.125) in. in from the other corner (Figure 16.4.2.2.1).

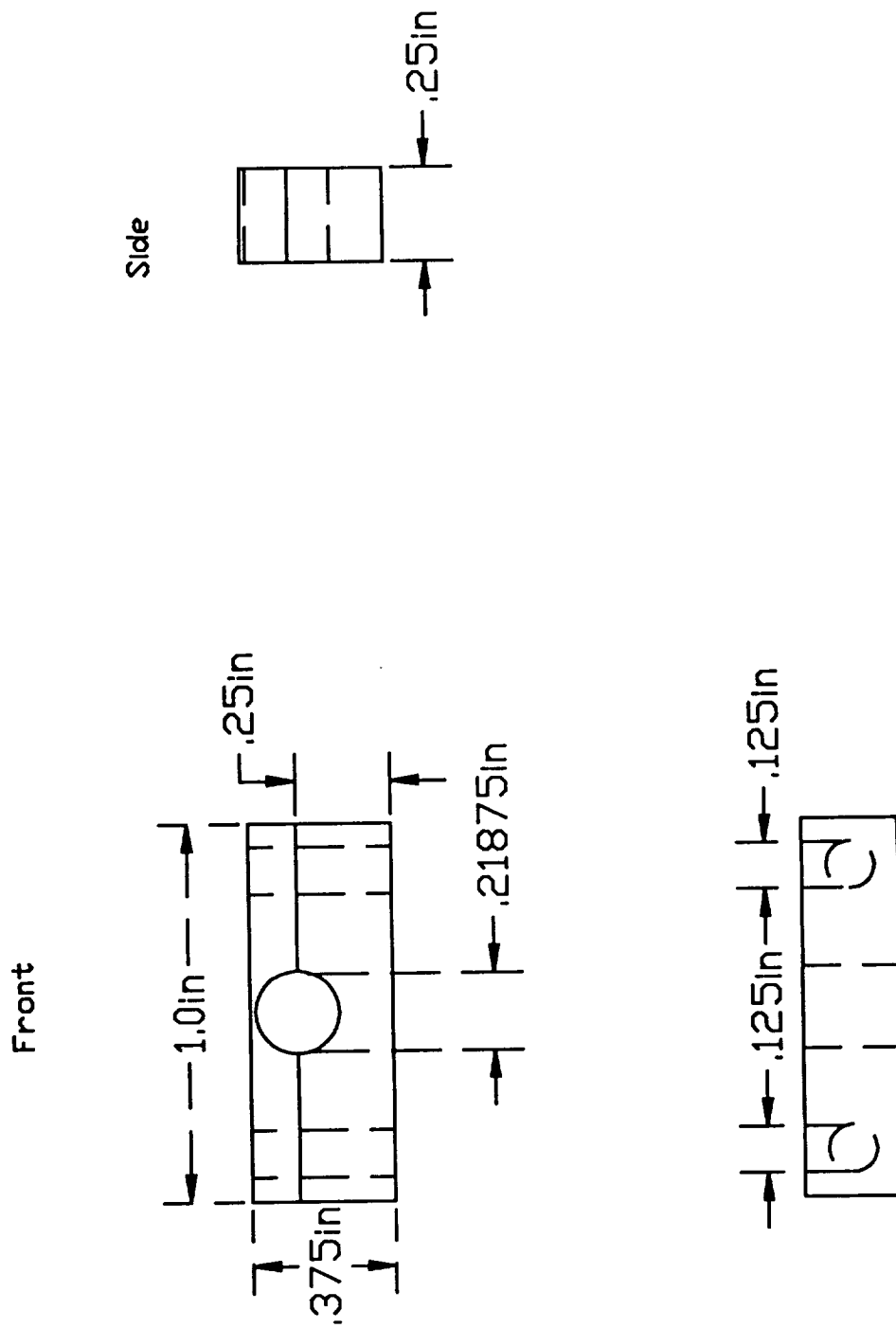

Figure 16.4.2.2.1 Mounting Bracket

- 16.4.2.4 Section block using table saw at $1/4$ (.25) in. up from the base (Figure 16.4.2.2.1).
- 16.4.2.5 Repeat process for second bracket.
- 16.4.2.6 Drill two $1/8$ (.125) in. bolt holes through link 4 at $1\ 1/8$ (1.125) in. out from the shaft and $3/8$ (.375) in. over from the centerline (Figure 16.4.2.6.1).
- 16.4.2.7 Drill one $1/8$ (.125) in. bolt hole through base plate at $1/8$ (.125) in. over and $1/8$ (.125) in. in from rear right corner (Figure 16.4.2.6.1).
- 16.4.2.8 Drill one $1/8$ (.125) in. bolt hole through base plate at $7/8$ (.875) in. over and $1/8$ (.125) in. in from rear right corner (Figure 16.4.2.6.1).
- 16.4.2.9 Bolt bottom sections of the mounting brackets through the pre-cut holes (steps 5 and 6) in link
- 16.4.3 Drive Channel
- 16.4.3.1 Cut the $7/32$ (.21875) in. aluminum tube to a length of $3\ 13/16$ (3.8125) in. (Figure 16.4.3.1.1).
- 16.4.3.2 Bend tube at the $1\ 7/8$ (1.875) in. mark to a 90 degree angle using a Mandrel bender.
- 16.4.3.3 Bend the tube at the $3\ 1/4$ (3.25) in. mark to a 100 degree angle using a Mandrel bender.
- 16.4.3.4 Place tube within mounting brackets and secure by tightening the bolts on the top of the mounting brackets.
- 16.4.3.5 Push plastic actuator wire through the tube.
- 16.4.3.6 Attach tube to actuator arm extension using JB Weld.
- 16.4.3.7 Insert front of actuator link 1 into collar located in the front of arm link 1 and tighten set screw using an Allen wrench to secure actuator (Figure 1.4.3.7.1).
- 16.4.4 Winding Assembly
- 16.4.4.1 Cut a 3 x 6 in. segment of $1/4$ (.25) in. thick Lexan using a table saw.
- 16.4.4.2 Cut two extension blocks $3/4$ x 2 x $1/4$ in. (.75 x 2 x .25) out of Lexan using a table saw.

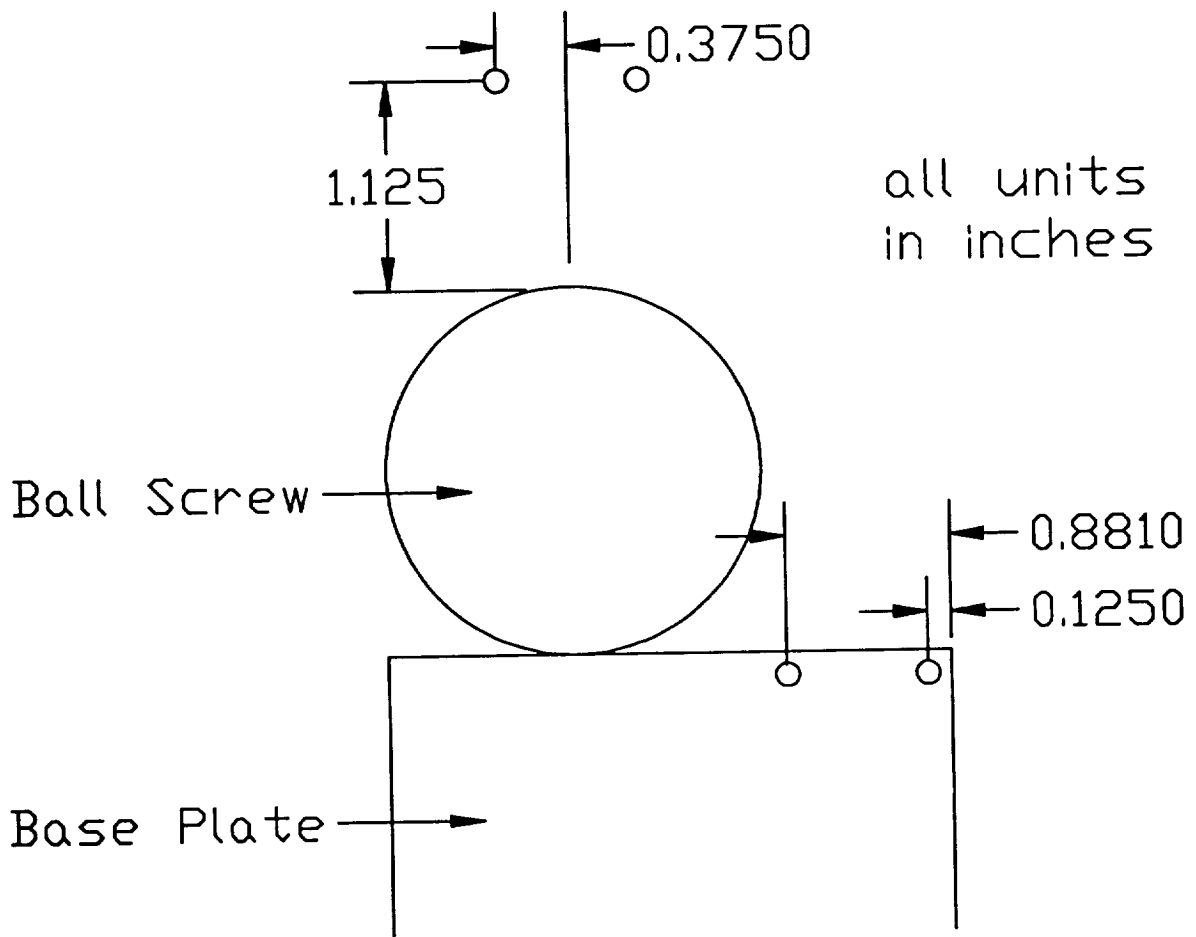
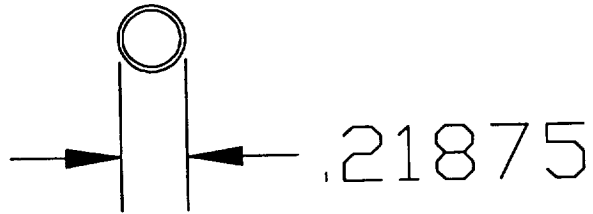
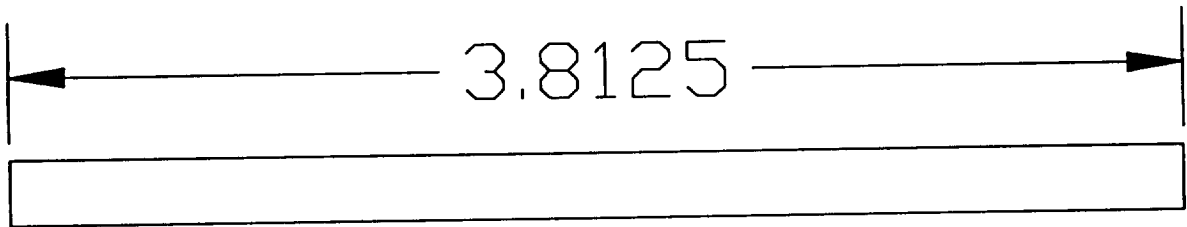

Figure 16.4.2.6.1 Mounting Bracket Drill Locations



ALL UNITS ARE IN INCHES

Figure 16.4.3.1.1 Tube Cutting Diagram

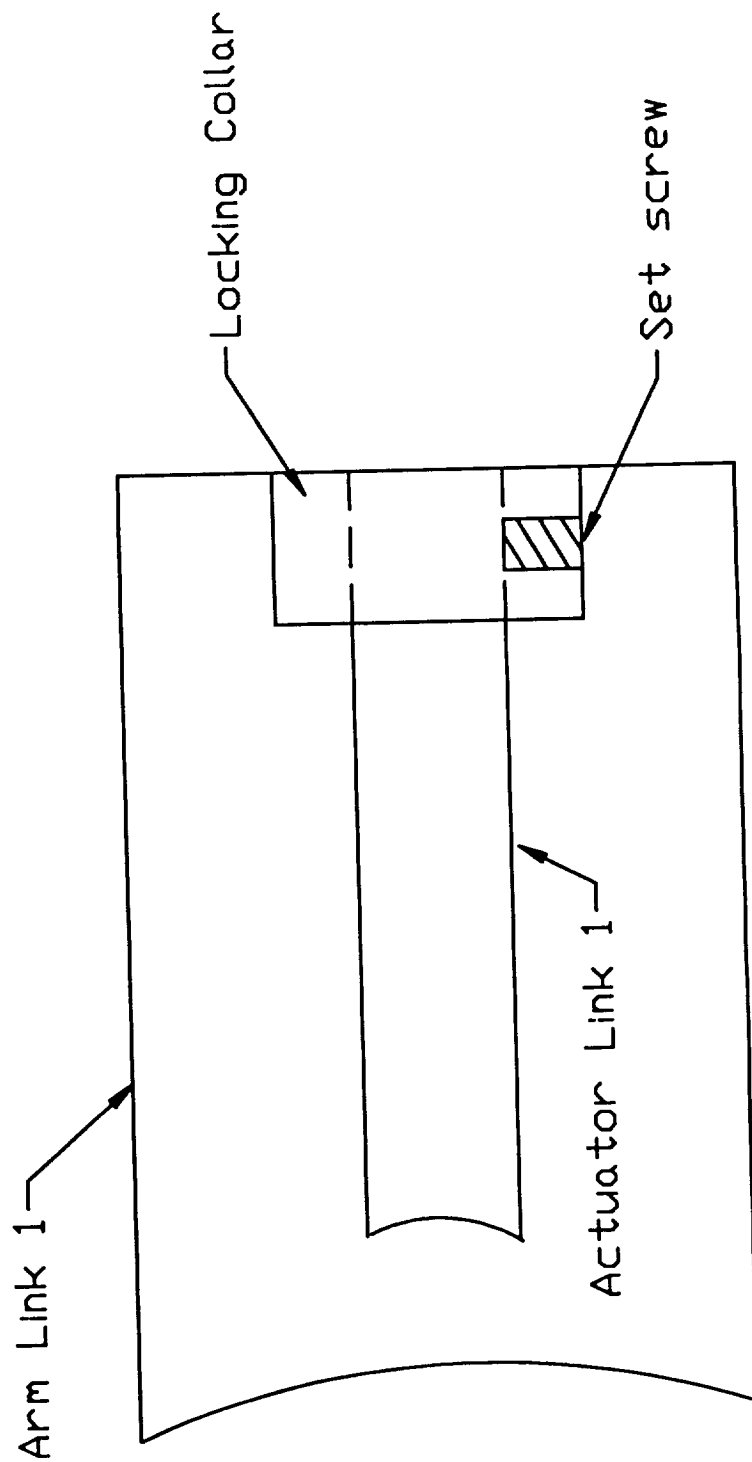

Figure 16.4.3.7.1 Actuator Fastening Collar

- 16.4.4.3 Glue Lexan extension pieces to Lexan block using Polycarbonate Cement SC-325. (Figure 16.4.4.3.1).
- 16.4.4.4 Using a standard steel 1/8 (.125) in. drill bit, drill three axial 1/4 (.25) in. deep holes for drive wheels and take-up assembly (Figure 16.4.4.4.1).
- 16.4.4.5 Tap spring loaded take-up reel assembly into axial hole using a small hammer.
- 16.4.4.6 Place 3/8 (.375) in. O-ring into groove on drive-pulley.
- 16.4.4.7 Slide in drive axle until 1/4 (.25) in. of the axle protrudes from the top of the drive pulley.
- 16.4.4.8 Slide inverted 4 mm hexagonal socket over the top of the drive pulley and JB Weld.
- 16.4.4.9 Tap drive wheel assembly into axial hole using a hammer (Figure 16.4.4.9.1).
- 16.4.4.10 Repeat steps 6 through 9 for second drive assembly.
- 16.4.4.11 Drill 1/4 (.25) in. hole in the top of link 4, 6 in. from the front and 1 7/8 (1.875) in. from the center line.
- 16.4.4.12 Feed arm extension wire through wheels and attach to take-up assembly by the use of the small hole in the reel.
- 16.4.4.13 Glue winding assembly plate onto the Lexan supports (attached to link 4) so that the front of the plate is flush with the front of link 4.
- 16.4.4.14 Insert drive axle through the top of link 4 and secure into hexagonal socket.

16.5 MODEL STAND

The stand for the UCF model of the CELSS chamber robot arm is designed for strength, simplicity, ease of operation, and transportation. The general design consists of a 48 X 48 X 0.25 inch aluminum base, a 2.006 inch diameter aluminum sleeve supported by four equally spaced 8 X 8 X 0.25 inch triangular flanges and a 5.5 ft steel pipe (Figure 16.5.1). Special pin holes in the steel pipe allow the Lexan model of the telescoping arm to be supported through the use of a 0.5 inch diameter steel pin which is 8 inches in length. The tolerances between the aluminum sleeve and the steel pipe will be 0.003 inch to prevent material binding between the sleeve and the steel pipe. The four aluminum flanges are welded onto the aluminum sleeve, and both the sleeve and the flanges are welded to the rectangular base. The actual steps for construction are as follows:

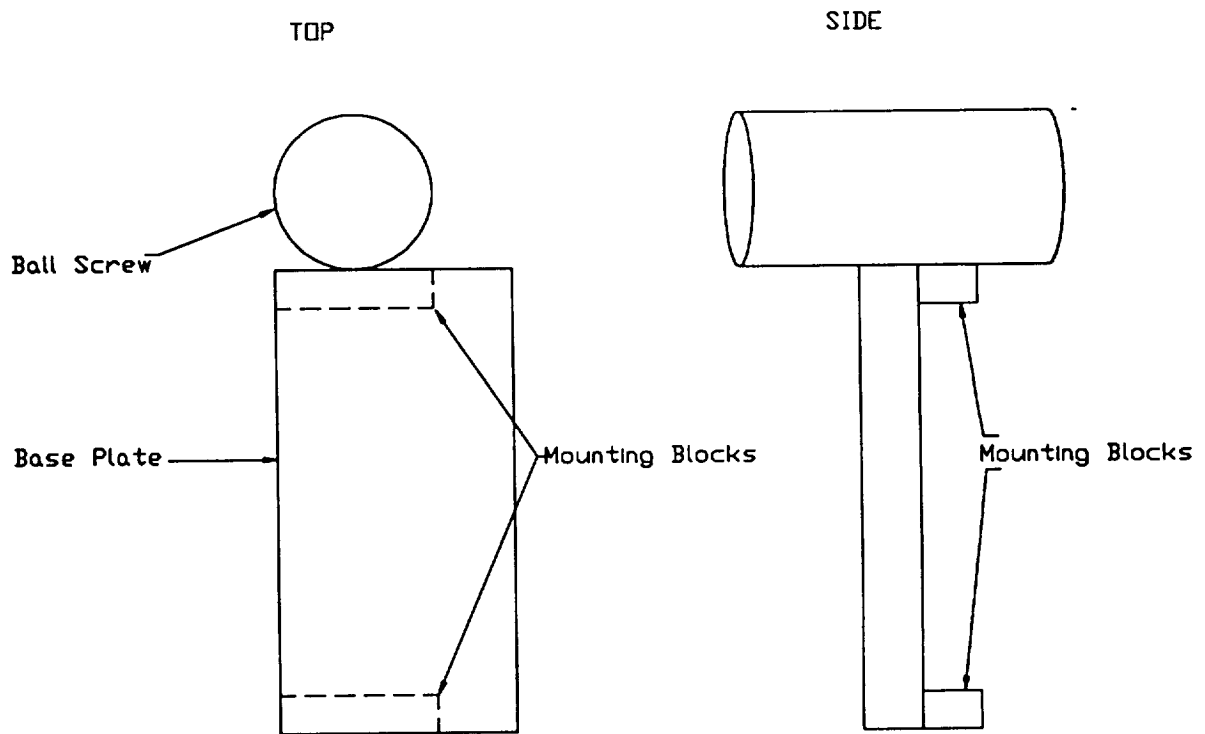

Figure 16.4.4.3.1 Extension Block Placement

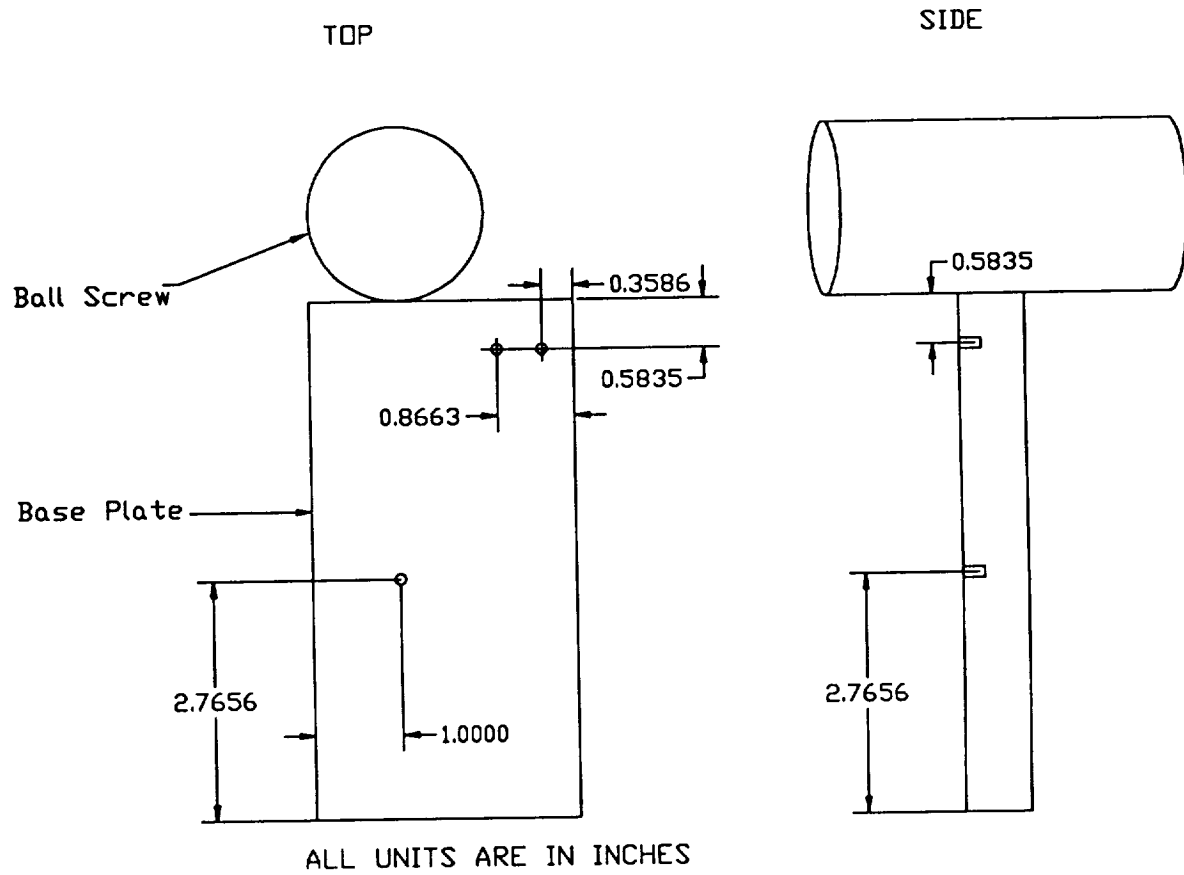
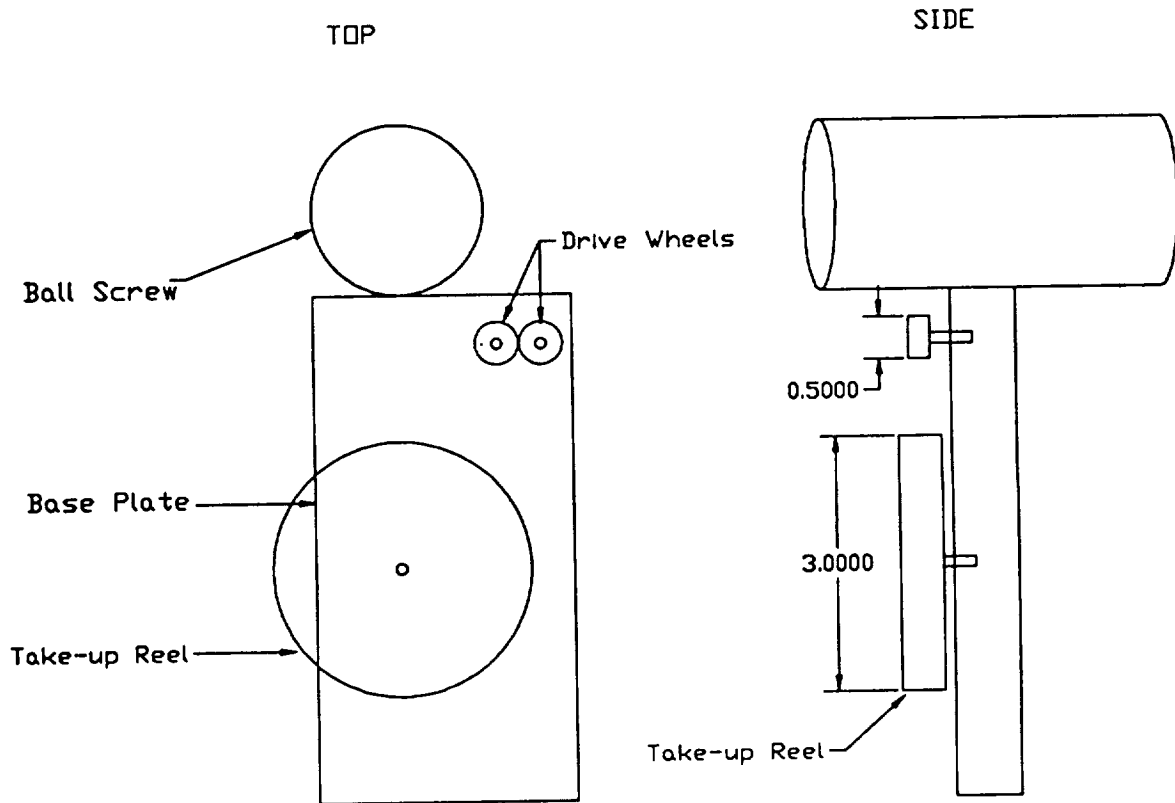

Figure 16.4.4.4.1 Drive and Take-up Assembly Drill Locations



NOTE: ALL UNITS ARE INCHES.

Figure 16.4.4.9.1 Take-up Assembly Placement

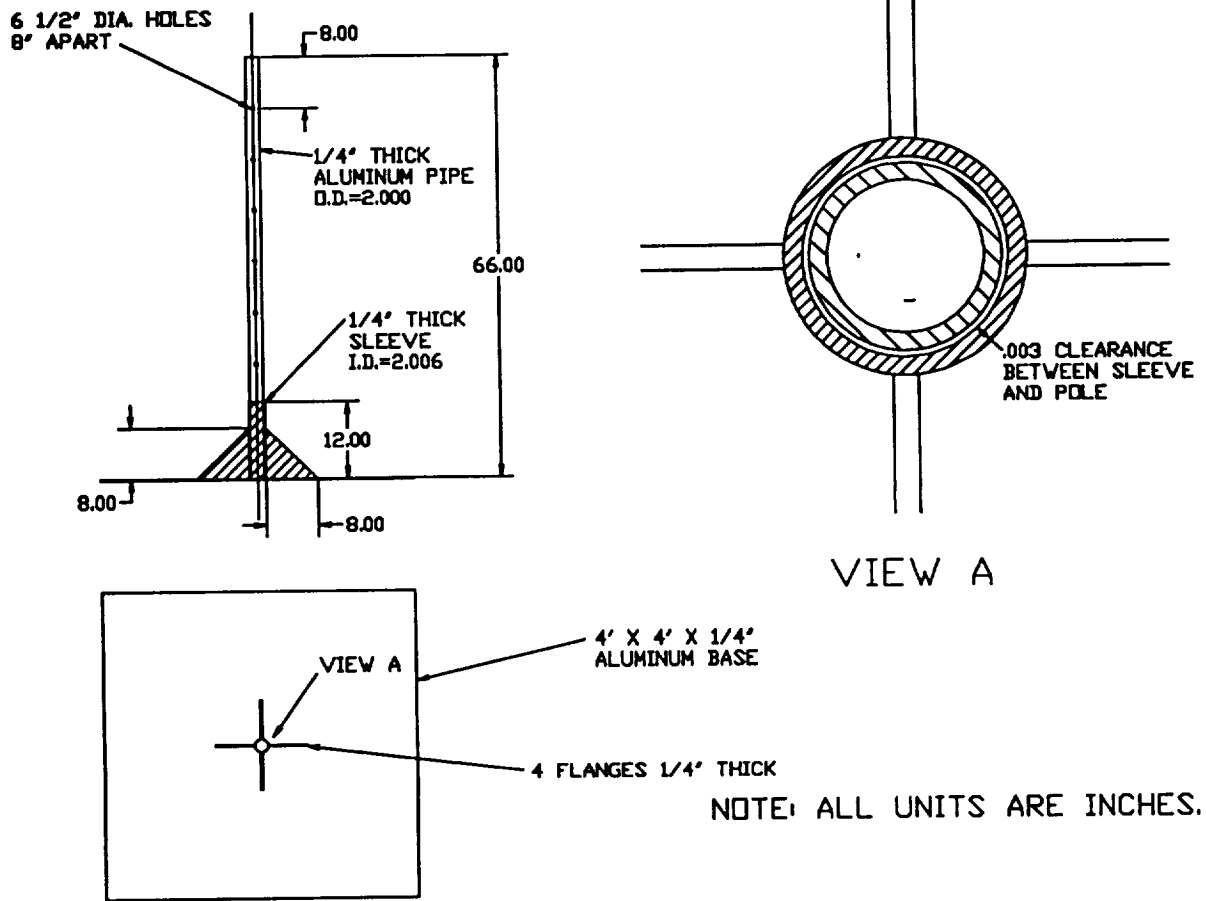

Figure 16.5.1 Model Stand

- 16.5.1 Obtain a 48 X 48 X 0.25 inch section of sheet aluminum to serve as the model base.
- 16.5.2 Obtain a 16 X 8 X 0.25 inch section of sheet aluminum and cut it into 4 right triangles each with a 6 inch base and 8 inches in height. Sand off all sharp edges with standard metal file.
- 16.5.3 Obtain a 12 inch length section of aluminum pipe with an inner diameter of 2.006 inches to serve as the sleeve.
- 16.5.4 Weld the 8 inch section of each triangular flange to the aluminum sleeve at 90 degree intervals.
- 16.5.5 Place the sleeve and flange assembly onto the center of the square aluminum base with the flanges perpendicular to the center of each 48 inch side of the base.
- 16.5.6 Weld each 8 inch base of the four triangular flanges and the base of the aluminum sleeve securely to the square base.
- 16.5.7 Obtain a 2 inch outer diameter section of steel pipe that is 5.5 feet in length.
- 16.5.8 Drill six 0.5 inch diameter pin holes into the steel pipe using a drill press and standard metal drill bit. Space these pin holes at 8 inch intervals measuring from the top of the pipe in a straight line.
- 16.5.9 To assemble model stand for use, place the 5.5 ft steel pipe into the aluminum sleeve and pin the Lexan model of the arm securely using an 8 inch, 0.5 inch diameter steel pin.
- 16.6 AESTHETICS
 - 16.6.1 Guidelines
 - 16.6.1.1 This section will give instructions as to the appearance of the telescopic link. All pre-operational procedures will be adhered to by all team members involved in the setting up of the telescopic link.
 - 16.6.2 Pre-Operational Procedure
 - 16.6.2.1 Inspect the arm for sharp edges visually before the telescopic link is installed into the chamber.
 - 16.6.2.1.1 File down all sharp edges by using a fine file or 600-800 grit sandpaper. Then, inspect all edges with hand to ensure a smooth finish.

- 16.6.2.2 Remove any tools not used in the operation of the telescopic arm from the CELSS chamber before the telescopic link is attached as not to interfere with the operation.
- 16.6.2.3 Paint the stool and bottom platform. The paint used is a spray paint called Zinc-Chromate. Zinc-Chromate is a spray paint of yellowish color and is available at any hardware store. (A more suitable color may be applied over the zinc-chromate).
- 16.6.2.4 Clean the Lexan telescopic links with liquid alcohol or liquid freon before the telescopic link is brought into the CELSS chamber.
- 16.6.2.5 Install the NASA and UCF logos to the side of main link (first link above the stand). If the logos have to be glued to the telescopic link, use a silicon type adhesives, i.e. silicon glue.
- 16.6.2.6 If buffing of the Lexan is desired, a stainless composition called lead-center muslin will be required. This component is a buffing pad attached to a portable drill. Apply medium pressure since heavy pressure tends to burn or distort the Lexan. After the buffing is complete, wipe Lexan with liquid alcohol or liquid freon.

Chapter 17.0 SCHEDULING

Logic and Gantt charts are used to maintain an orderly design schedule. The Gantt chart is used to separate each task and provide a timetable for its beginning and completion. The Logic chart shows the sequence in which each task is placed along the design path.

17.1 LOGIC CHART

To show the order in which each task is performed, a Logic chart has been constructed. A Development Logic chart shows the path of the overall design process, and a Test Logic chart shows the test process.

The Development Logic chart (Figure 17.1.1) begins with the orientation of new members and the reestablishment of design objectives. The system design has been modified to accommodate these new objectives. A model design was derived for the testing of the telescoping arm on-site at NASA. Rough drawings will be developed into detailed drawings for fabrication of a final working plan. Material selections were made using kinematic and deflection analyses. Vendors and/or manufacturers will be found for all model components. Procurement of components will begin on 2/17/94. Pre-testing of components and model assembly will be completed by 3/24/94.

Testing of the model will be performed as shown in the Testing Logic chart (Figure 17.1.2). Pretesting of components will include; crack, dimension, hole alignment, burr, adhesive/fastener, bearing mounting, load, actuation, collapsibility, cable reel, stand

attachment, stability, safety, and aesthetics. Testing of the model on-site will include: fit, deflection.

17.2 GANTT CHART

Graphical display of the design scheduling is shown in the Development Gantt chart (Figure 17.2.1) and the Testing Gantt chart (Figure 17.2.2). These charts will be used to track the progress of the project.

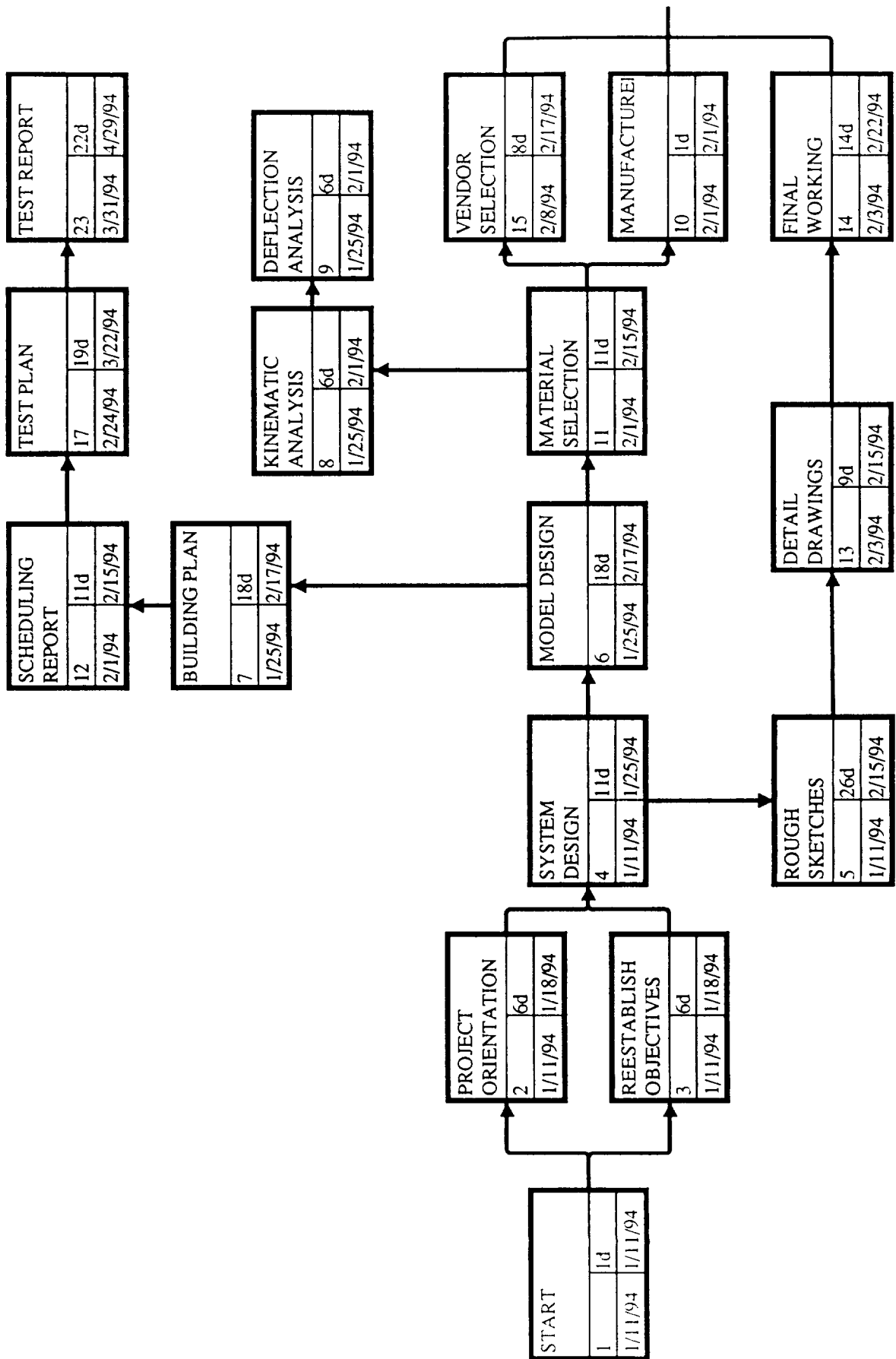

Figure 17.1.1a Development Logic Chart

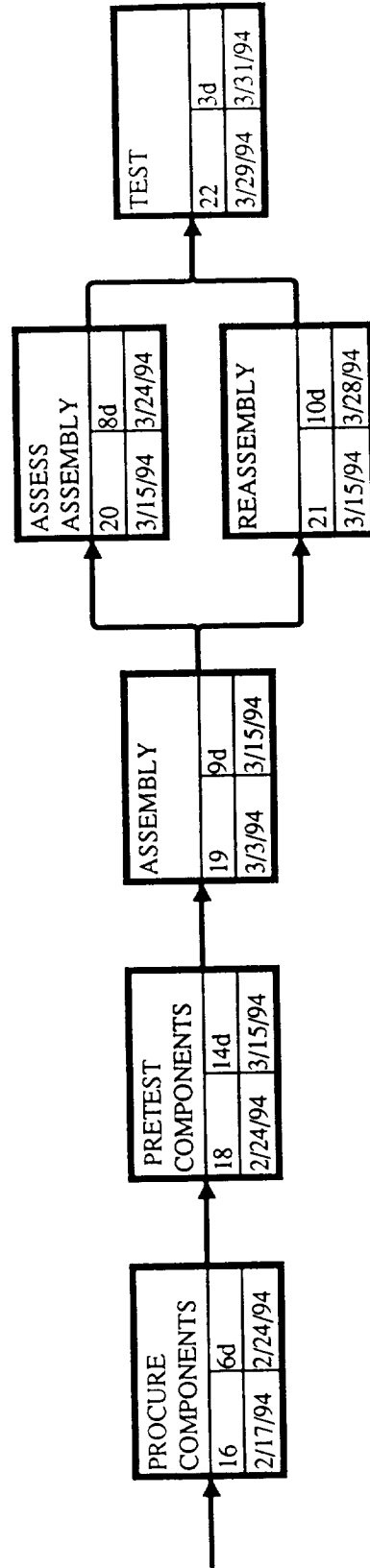

Figure 17.1.1b Development Logic Chart

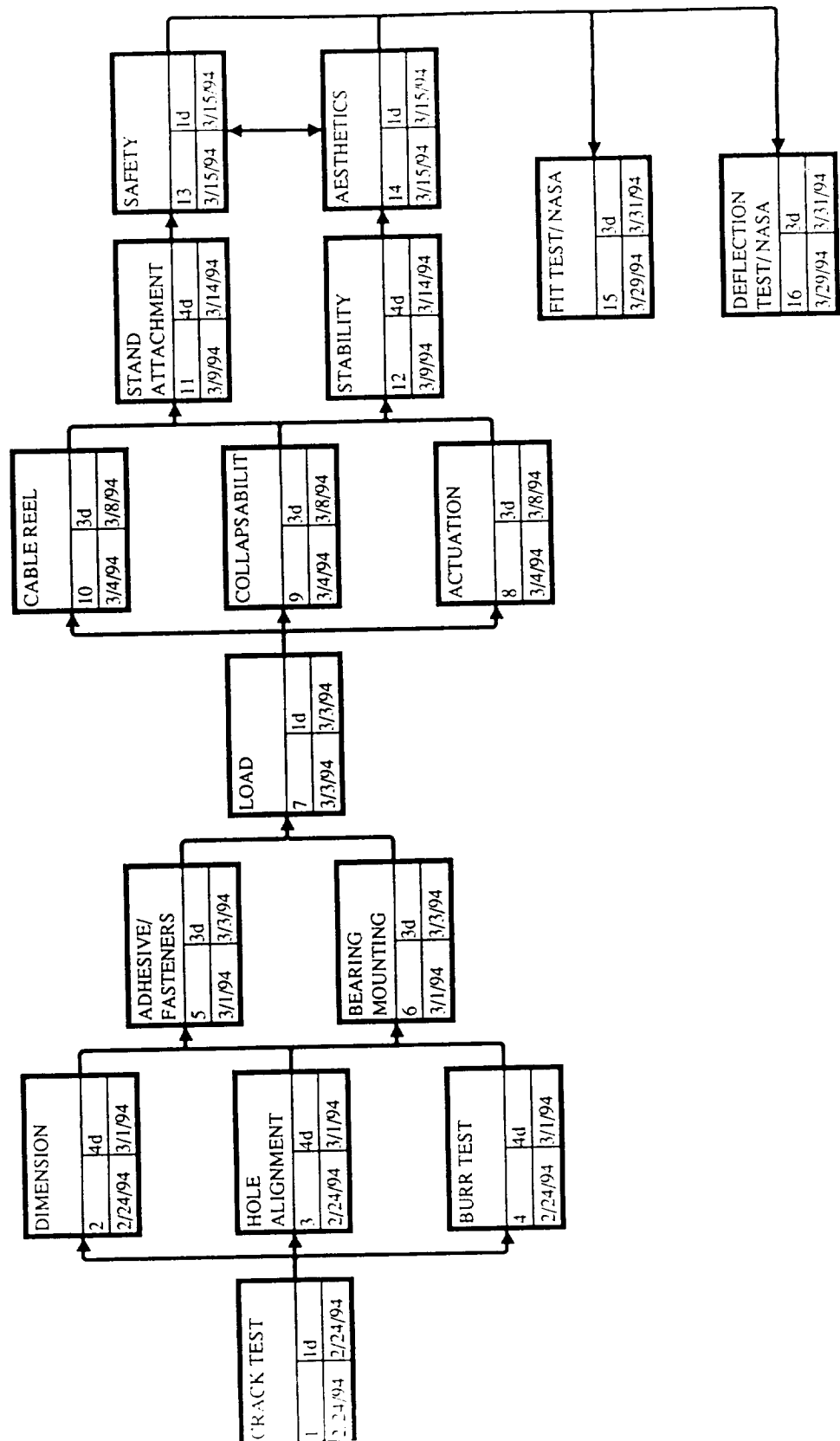

Figure 17.1.2 Testing Logic Chart

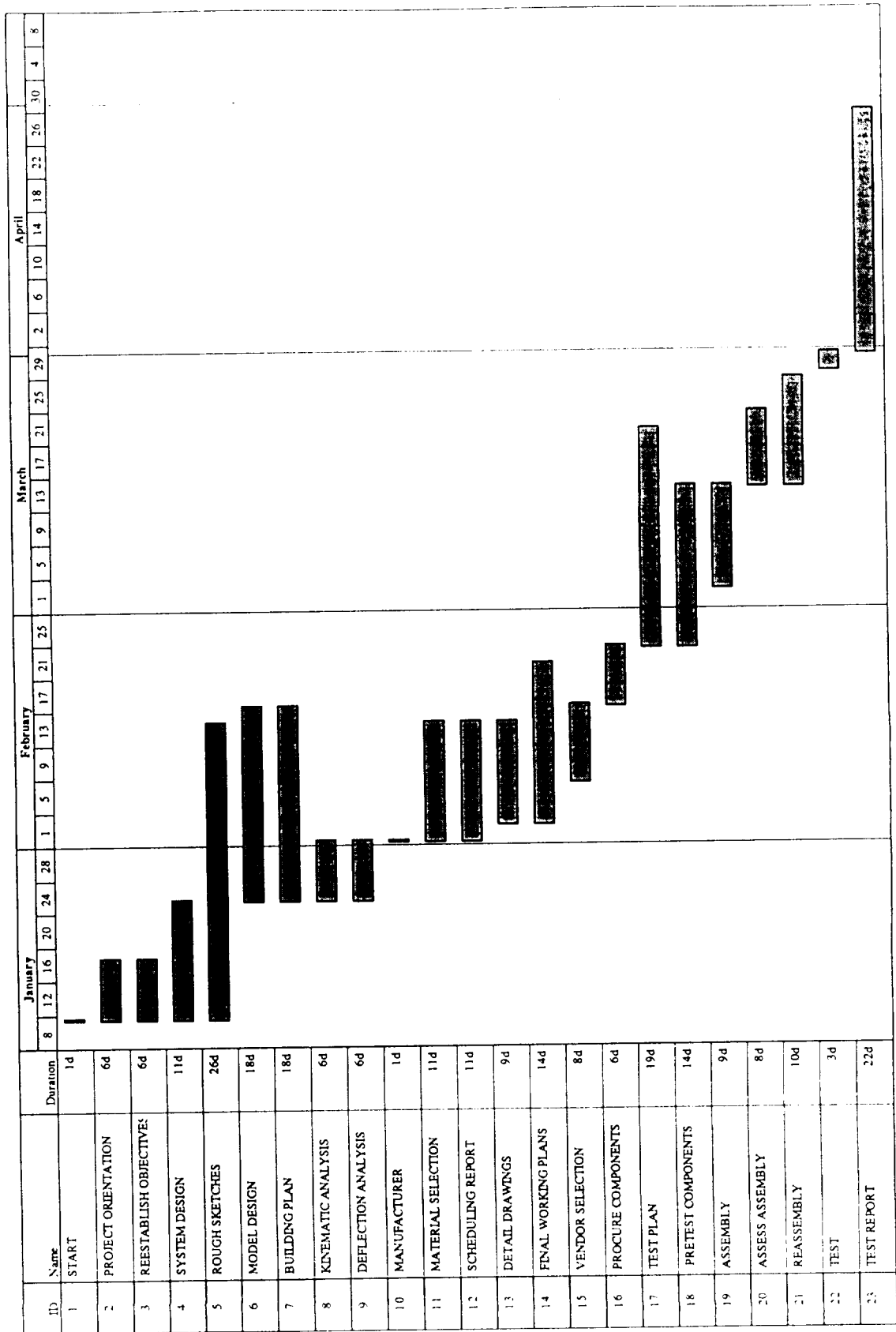

Figure 17.2.1 Development Gantt Chart

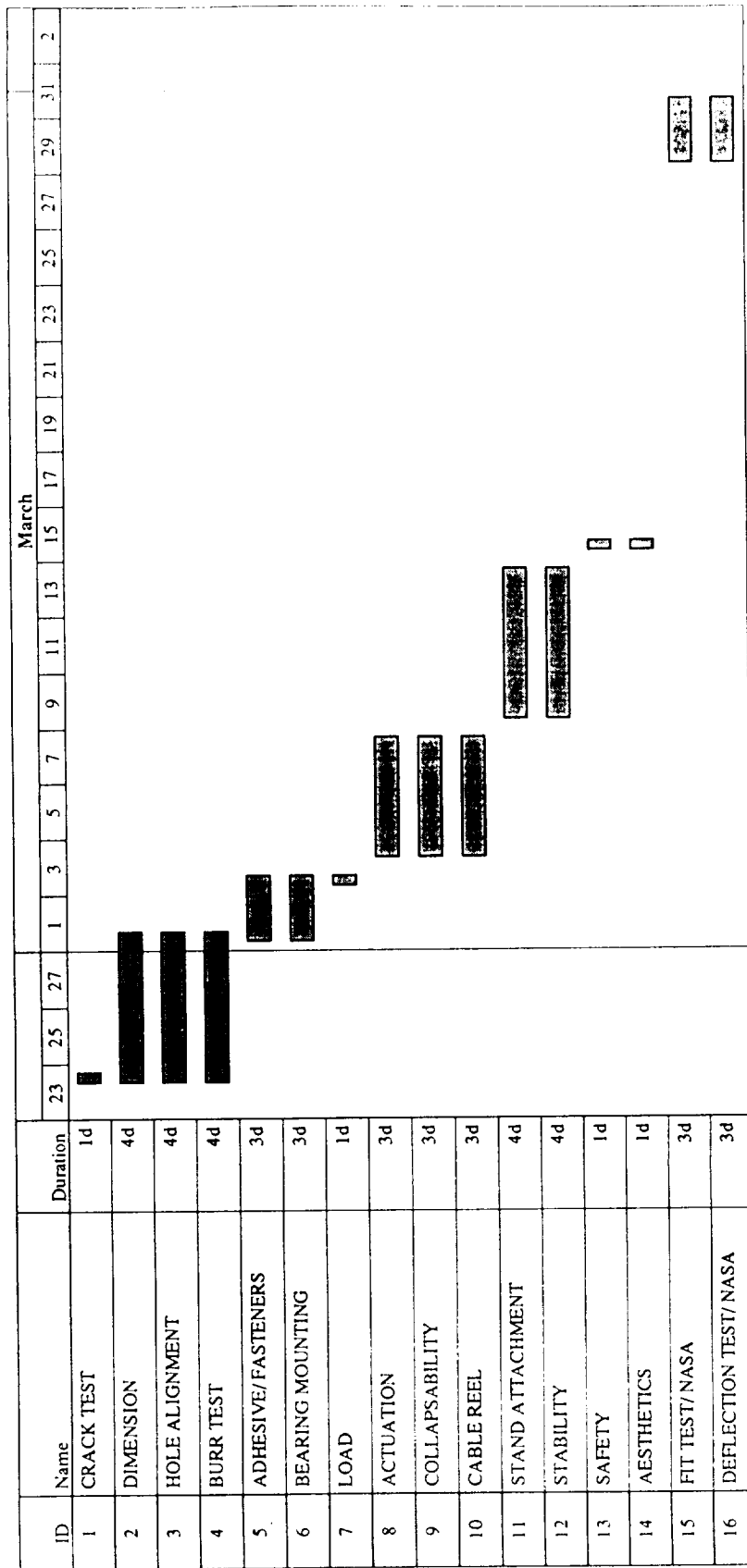

Figure 17.2.2 Testing Gantt Chart

SECTION V

REDESIGN OF ROBOT

CROSS SECTION

- * SQUARE, RECTANGLE, TRIANGLE, DIAMOND

BEARINGS

- * MOUNTING

ACTUATOR

- * DRIVE MECHANISM
- * TAKE-UP REEL

SEQUENCING

- * ROLLER BALL PLUNGER

BELLOWS

DUAL "V" GUIDE SYSTEM

- * STEEL TRACKS
- * GEARS

CABLE REEL

BALL SCREW INTERFACE PLATE

- * REMOVAL PLATE
- * BRAKING MECHANISM

STRESS AND DEFLECTION ANALYSIS

- * COMPUTER ANALYSIS
- * VERIFICATION CALCULATIONS

Chapter 18.0 REDESIGN OF ACTUAL CELSS CHAMBER ROBOT

18.1 INTRODUCTION

The previous chapters describe the techniques for constructing the CELSS robot model. The class changed focus at this junction and began redesigning the actual CELSS robot work that was done last semester. The students started at the basics and redesigned the telescopic arm. Cross section of the arm as well as the bearings used to facilitate sliding were investigated. The actuator was changed from a linear ball screw design into a push cable design. A method of sequencing of the arm links was determined. Bellows for the arm were looked at to aid in cleanliness. A V-guide bearing was used to replace the turntable bearing. The cable reel was examined to determine if a lighter alternative was available. The aluminum interface plate was replaced with a steel plate. A stress analysis was completed on the new overall actual design.

Chapter 19.0 ROBOT ARM CROSS SECTION ANALYSIS

19.1 INTRODUCTION

After going over the initial design for the robot arm, it was decided that improvements could be made to enhance the design. In particular, the cross section design for the arm needed to be finalized. It was decided that four different shapes should be looked at and compared. The four shapes suggested were: the square, the rectangle, the equilateral triangle and the equal axial diamond (Figure 19.1.1). The comparison test for these cross sections included an area moment of inertia. From the flexural formula for the deflection in a cantilever beam due to an applied load in the vertical direction, $v = PL^3/3EI$, it can be seen that the larger the I value the smaller the deflection. The main reason for this analysis is to reduce the amount of deflection and maintain torsional stability while keeping the overall size of the arm to a minimum. To obtain a fair comparison of the different cross sections, a material with a perimeter of 25.4 cm by 3 mm thick was used to make each of the shapes. The area moment of inertia was then calculated for comparison. The shape which yielded the greatest moment of inertia would be the optimum cross section design.

19.1.1 Square Cross Section

The first shape looked at was the square. Its dimensions were 6.35 cm on a side by 3 mm thick. The equation used to calculate the area moment of inertia was $I = bh^3/12$, where b = base dimension and h = the height. The outside dimensions were used to calculate a moment of inertia for the solid. The area moment of inertia was also calculated for the hole. Next, the hole was subtracted from the solid which produced an area moment of inertia of $444.0 \times 10^{-9} \text{ m}^4$ with a cross section area of 40.32 cm^2 .

CROSS SECTIONS OF LINKS

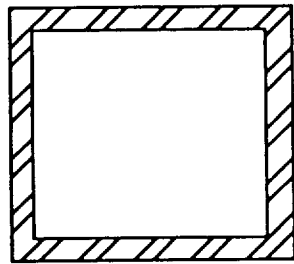

SQUARE

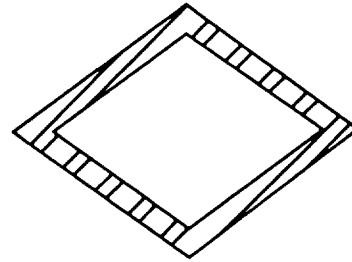

DIAMOND

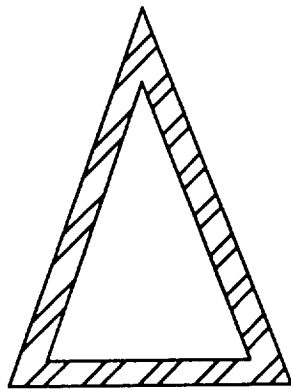

TRIANGLE

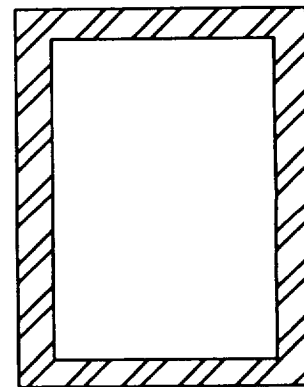

RECTANGLE

Figure 19.1.1 Cross Sections

19.1.2 Rectangular Cross Section

The second shape to be analyzed and compared was the rectangle. The rectangle was oriented so that it measured 7.62 cm tall by 5.08 cm wide. The area moment of inertia was calculated in the same manner as the square. This calculation yielded an improved value of $581.5 \times 10^{-9} \text{ m}^4$. The cross section area was slightly reduced to 38.71 cm^2 .

19.1.3 Triangular Cross Section

When the equilateral triangle shape was used for evaluation, the area moment of inertia was calculated using the equation $I = bh^3/36$. This resulted in a reduction in the area moment of inertia and the cross section area for a triangle measuring 8.47 cm^2 on all side. The area moment of inertia calculated for this shape was $281.7 \times 10^{-9} \text{ m}^4$. This was the smallest value calculated and would result in a greater deflection if used. The cross section area was 31.04 cm^2 for the triangle.

19.1.4 Diamond Cross Section

The last shape to be analyzed was the equal axis diamond. This is simply the square turned 45 degrees so it sits on one of its corners. The area moment of inertia was found by integrating over the area, A, of the shape using the equation $(y^2)dA$. Once again an I value was found for the solid and the hole. The I value of the hole was subtracted from that of the solid. The final results were identical to that of the square calculations above giving an I value of $444. \times 10^{-9} \text{ m}^4$ and an area of 40.32 cm^2 .

19.2 OBSERVATIONS AND RECOMMENDATIONS

From the values acquired during the analysis of the different shapes, the triangle and diamond were ruled out. The triangle did not produce a favorable value for its moment of inertia. Furthermore, the cross section does not provide enough room for running service cables. The diamond shape analyzed did not have the loading characteristics compatible with an 'off the shelf' bearing. A diamond shaped cross section which is taller than it is wide was discarded due to rapidly increasing dimensions from section to section. A combination of the square and rectangle were chosen to be used in the final design. These shapes gave the best combination of area moment of inertia and cross section area to provide the least amount of deflection while still providing enough room for service cables. After testing at the CELSS chamber it was discovered that the arm possessed too much horizontal reach because of a grating that encircles the inside of the chamber walls. Furthermore, the size of the end effector must be taken into consideration. It is suggested the third section of the arm be redesigned to accommodate this problem. By redesign the length of the third link and the forces in that bearing are reduced. It is possible a smaller bearing can be used. A table of the arm links dimensions is included in this report, Table 19.2.1.1.

TABLE 19.2.1.1
AREA MOMENT OF INERTIA AND CROSS SECTION AREA

	SQUARE	RECTANGLE	TRIANGLE	DIAMOND
CROSS SECTION AREA CM ²	40.32	38.71	31.04	40.32
I SHAPE 10 ⁻⁶ m ⁴	1.355	1.873	.9270	1.355
I-HOLE 10 ⁻⁹ m ⁴	910.9	1292.0	645.4	910.9
I-TOTAL 10 ⁻⁹ m ⁴	444.0	581.5	281.7	444.0

Chapter 20.0 BEARINGS

20.1 INTRODUCTION

There are several different types of bearings which perform a vast number of specialized tasks. The primary function of all bearings is to reduce the amount of friction between two contact surfaces. The type of bearing which best fits the needs of the CELSS robot arm is the slider bearing. A slider bearing consists of a track in which roller bearings, connected to a slightly smaller rail than the track, slides axially with respect to one another (Figure 20.1.1). A practical example of a slider bearing is the bearings used in cabinet drawers.

20.2 VENDOR SELECTION

After selecting the desired vendor, General Devices Inc., three models of slider bearings were chosen. The three models are LBS-11-18, LBS-21-18, and LBS-32-26. These bearings have a maximum load capacity of 489.3 N, 1001 N, and 2980 N respectively, with a manufacturer factor of safety of 2.

20.3 BEARING DESCRIPTION

The three bearings chosen are the LBS-11-18, the LBS-21-18 and the LBS-32-26. The LBS-11-18 slider bearing is constructed of two links. The fixed link is a C-channel which encases the second link. The two links are separated by two rows of ball bearings (Figure

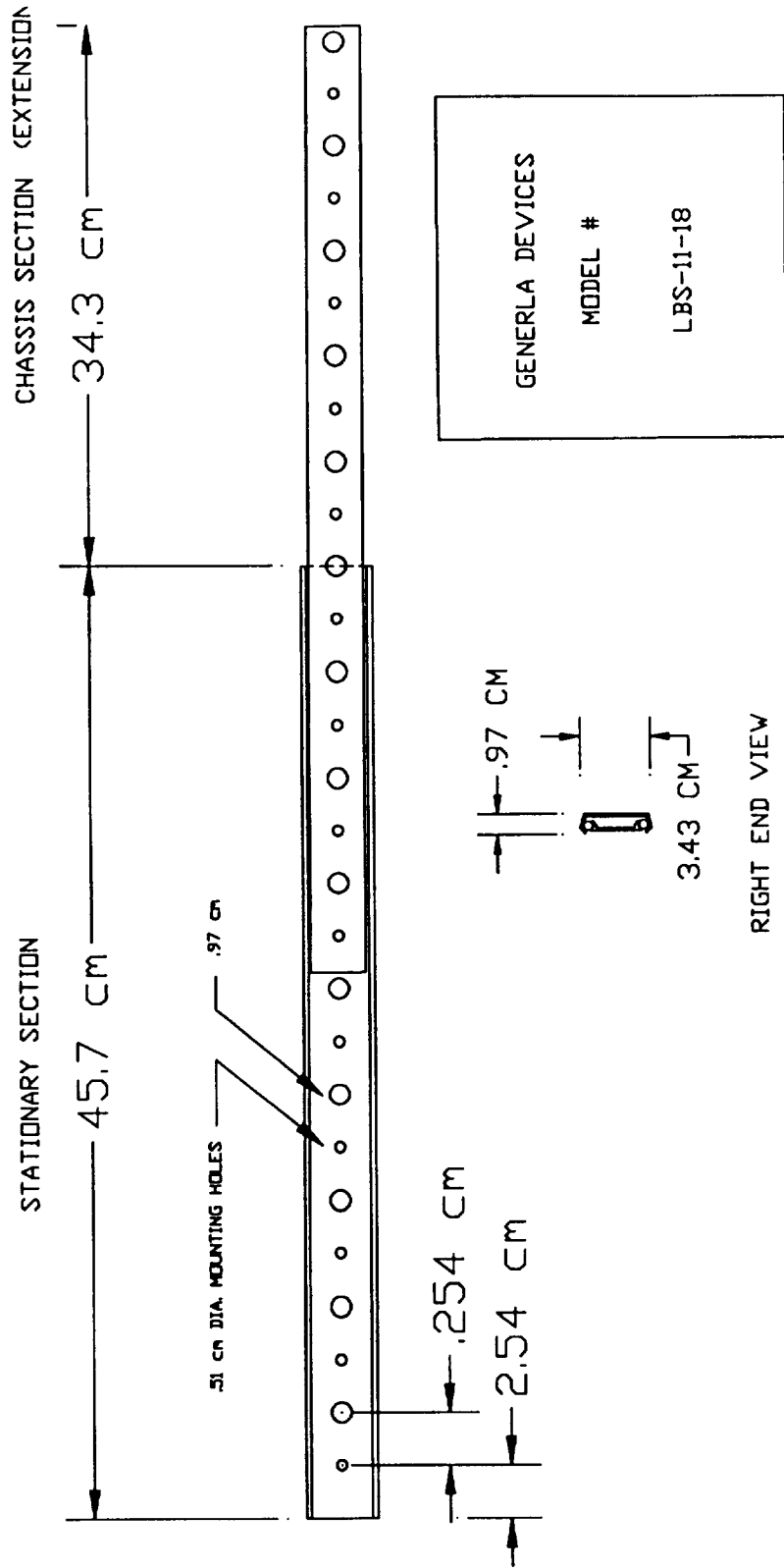

Figure 20.1.1 Bearing LBS-11-18

20.1.1). The LBS-21-18 slider bearing consists of two sets of C-channels with four rows of ball bearings (Figure 20.3.1). The largest bearing, LBS-32-26, consists of three sets of C-channels with six rows of ball bearings (Figure 20.3.2).

20.4 MATERIAL PROPERTIES

The slide members are made from 14 gauge work hardened, cold rolled steel. The slide in which the bearings roll is plated with zinc for a lower coefficient of friction and corrosion resistance. The operational temperature range specified by the manufacturer is -4°C to +337°C, which is well within the temperature range of the CELSS chamber.

20.5 MOUNTING

All slides are mounted to the sides of the robot arm links by # 8-32 x 3/8 inch slotted pan head screws and self locking nuts. The interface between link 1 and link 2 is supported by using the LBS-11-18 slide bearing. Link 2 and link 3 use LBS-21-18 slide bearings for support and link 3 and link 4 use LBS-32-26 for their interface. All bearings must be mounted parallel to the links they support.

20.6 EXTENSION AND OVERLAP

The LBS-11-18 and LBS-21-18 slider bearings have a collapsed length of 45.7 cm and an extendable length of 80 cm. For the robot arm, only 78.7 cm of extension is used for these bearings yielding a 12.7 cm overlap between link 1 and link 2, and link 2 and link 3 when fully extended. The LBS-32-26 slider bearing has a collapsed length of 66 cm and an extendable length of 134.6 cm. Only 132 cm of extension is used for link 3 and link 4.

20.7 SLIDE BEARING ANALYSIS

20.7.1 Introduction

While analyzing the slide bearings, two main concerns are encountered. The first concern is whether the bearings can support the vertical loading. The second being whether they can support the moment produced by the arm and payload. From a comparison to vendor specifications, vertical loading will not present problems. The moment produced by the arm's weight and payload will be the main concern.

20.7.2 Bearing Specifications

The slide bearings, LBS-11-18 (Figure 20.1.1) and LBS-21-18 (Figure 20.3.1), consist of two metal sections, a male section which is supported by ball bearings inside the female section. These two models have manufacturer load ratings of 489 N and 1001 N, respectively. The LBS-32-26 (Figure 20.3.2) consists of a triple row bearing having a

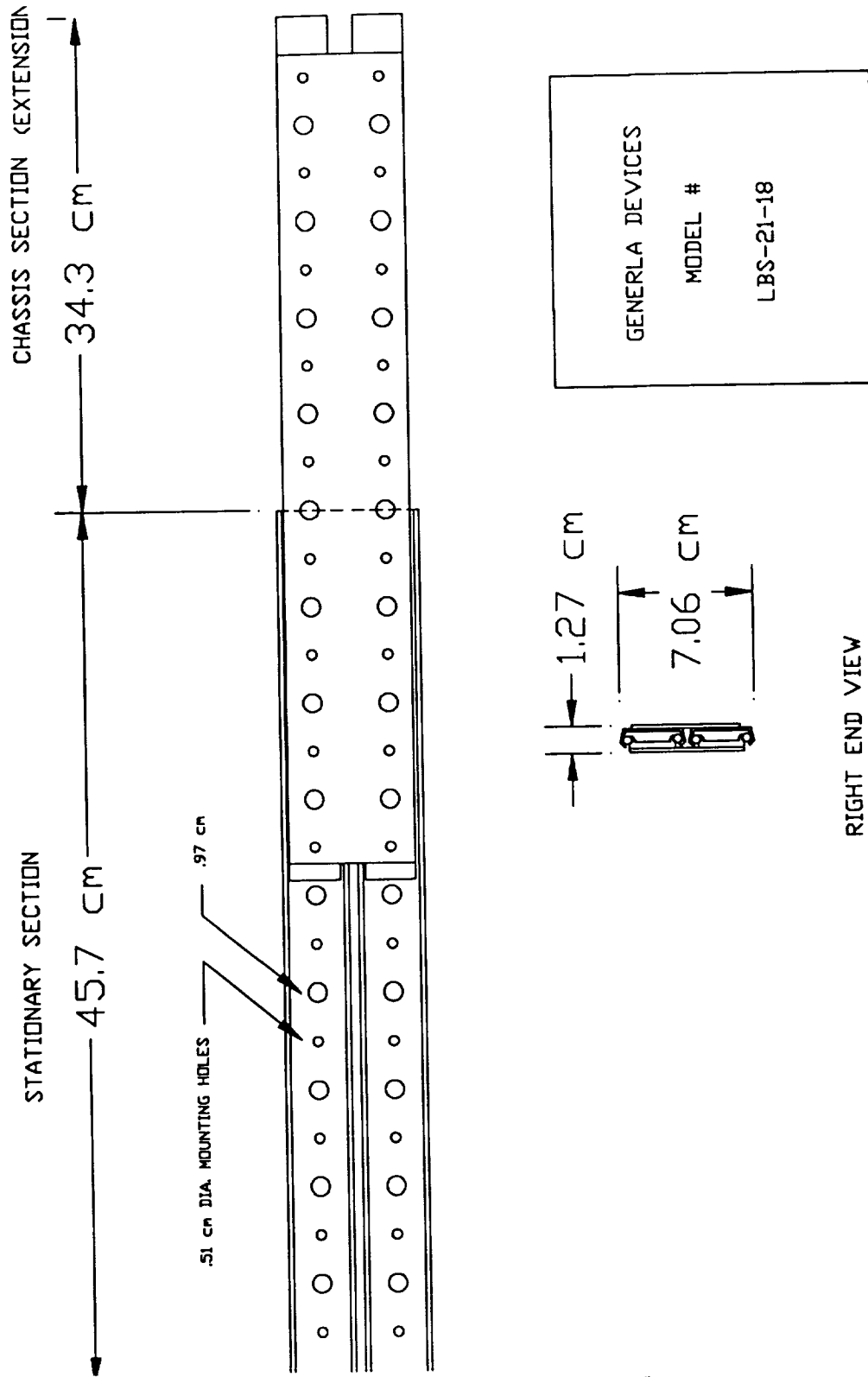

Figure 20.3.1 Bearing LBS-21-18

TOP VIEW EXTENDING



STATIONARY SECTION

66 cm

25 cm DIA INSULATING HOLES .87 cm

CHASSIS SECTION

68.6 cm EXTENSION CAPABILITY

66 cm

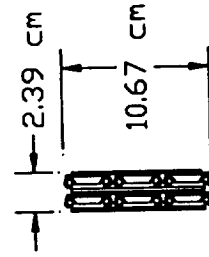

RIGHT END VIEW

GENERALA DEVICES
MODEL #
LBS-32-26

Figure 20.3.2 Bearing LBS-32-26

load rating of 2980 N. These load ratings are located at the midpoint of the extended section.

20.7.3 Maximum Bearing Loads

Reaction forces between the bearing segments for models LBS-11-18 and LBS-21-18 are modeled as two members and model LBS-32-36 is modeled as three members. The assumption is made that contact only occurs at each end of the bearing slide's overlap at full extension. The reaction forces become point loads at these locations. These forces are calculated by summing the moments about the end of the extended slide. This calculation yields the reaction force of the stationary section. The remaining unknown force is found by summing the forces in the vertical direction and setting that quantity equal to zero. From these point loads, shear and moment diagrams are constructed for allowable bearing loads. These diagrams show the maximum shear and moment values allowable for each set of bearings (Figures 20.7.3.1 - 20.7.3.3). These values are calculated using the manufacturer's suggested loading at the maximum extension lengths of the bearings. The actual extension lengths of the bearings are less than the manufacturer's suggested lengths. This will contribute to an increase of the safety factor.

20.7.4 Actual Bearing Loads

The weight of the aluminum arm links and the payload are used in a similar analysis as section 20.7.3 for the actual loadings. The reaction forces can be found and used to create shear and moment diagrams (Figures 20.7.3.1 - 20.7.3.3).

20.8 OBSERVATIONS AND RECOMMENDATIONS

- 20.8.1 The LBS-11-18 bearing, used between links 1 and 2, has a maximum allowable moment of 49.7 N*m. From the analysis of the first bearing, the expected moment is 49.5 N*m. This bearing provides sufficient strength for the link coupling.
- 20.8.2 The LBS-21-18 bearing, used between links 2 and 3, has a maximum allowable moment of 102 N*m. From the analysis of the second bearing, the calculated moment is 102 N*m. Since the manufacturer's data includes a safety factor of 2, the bearing is adequate.
- 20.8.3 The LBS-32-26 bearing, used between links 3 and 4, has a maximum allowable moment of 984 N*m. From the analysis of the second bearing, the calculated moment is 160 N*m. The bearing capacity is larger than needed.
- 20.8.4 The LBS-32-26 bearing is oversized for this application. A smaller size would satisfy the desired strength needed, however, one has not been located that meets the requirements.
- 20.8.5 The weights of the bearings were found by talking to a representative at General Devices. The LBS-11-18 weighs 11.1 N per pair, the LBS-21-18 weighs 22.2 N, and the LBS-32-

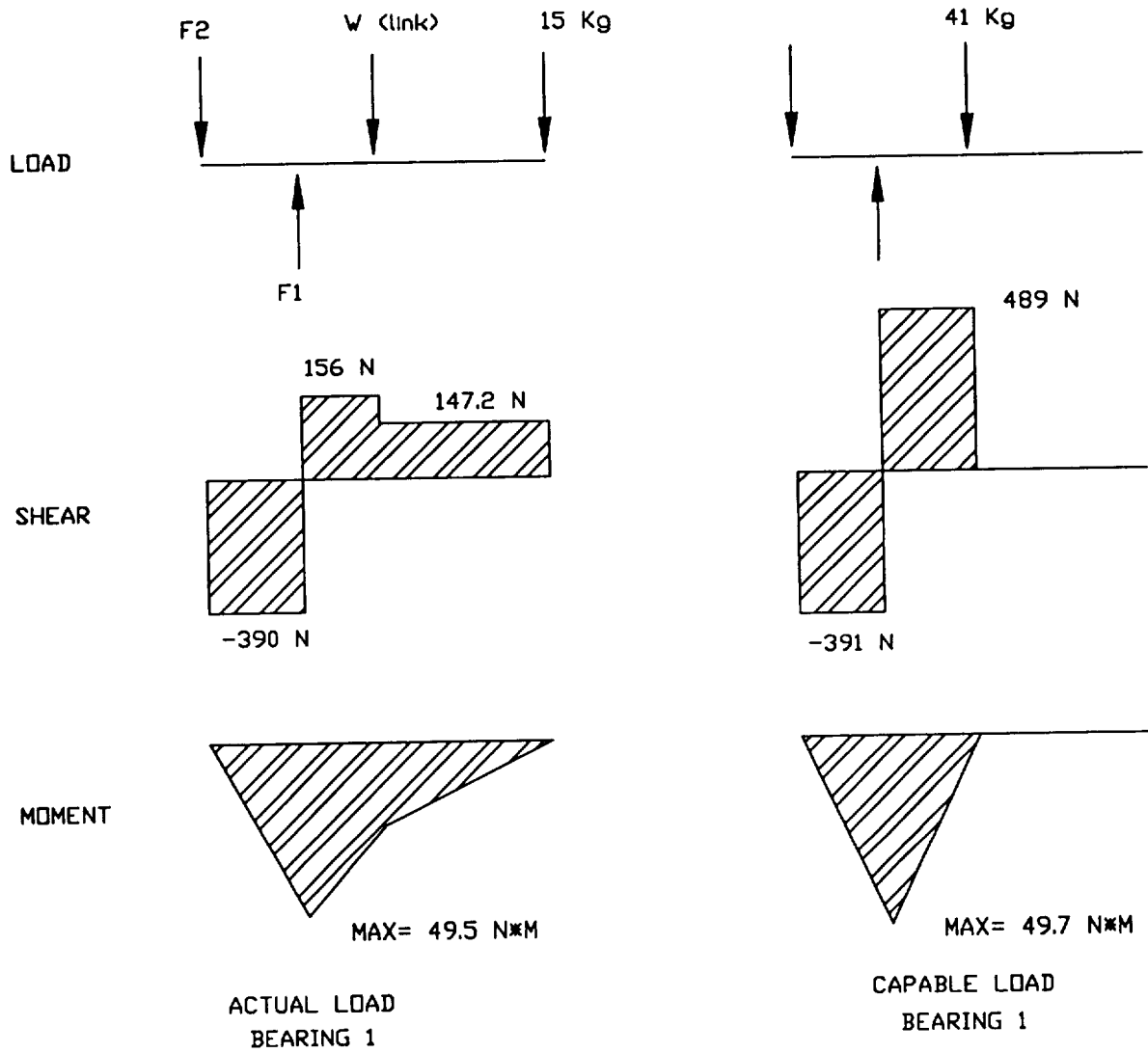

Figure 20.7.3.1 Shear/Moment Diagrams

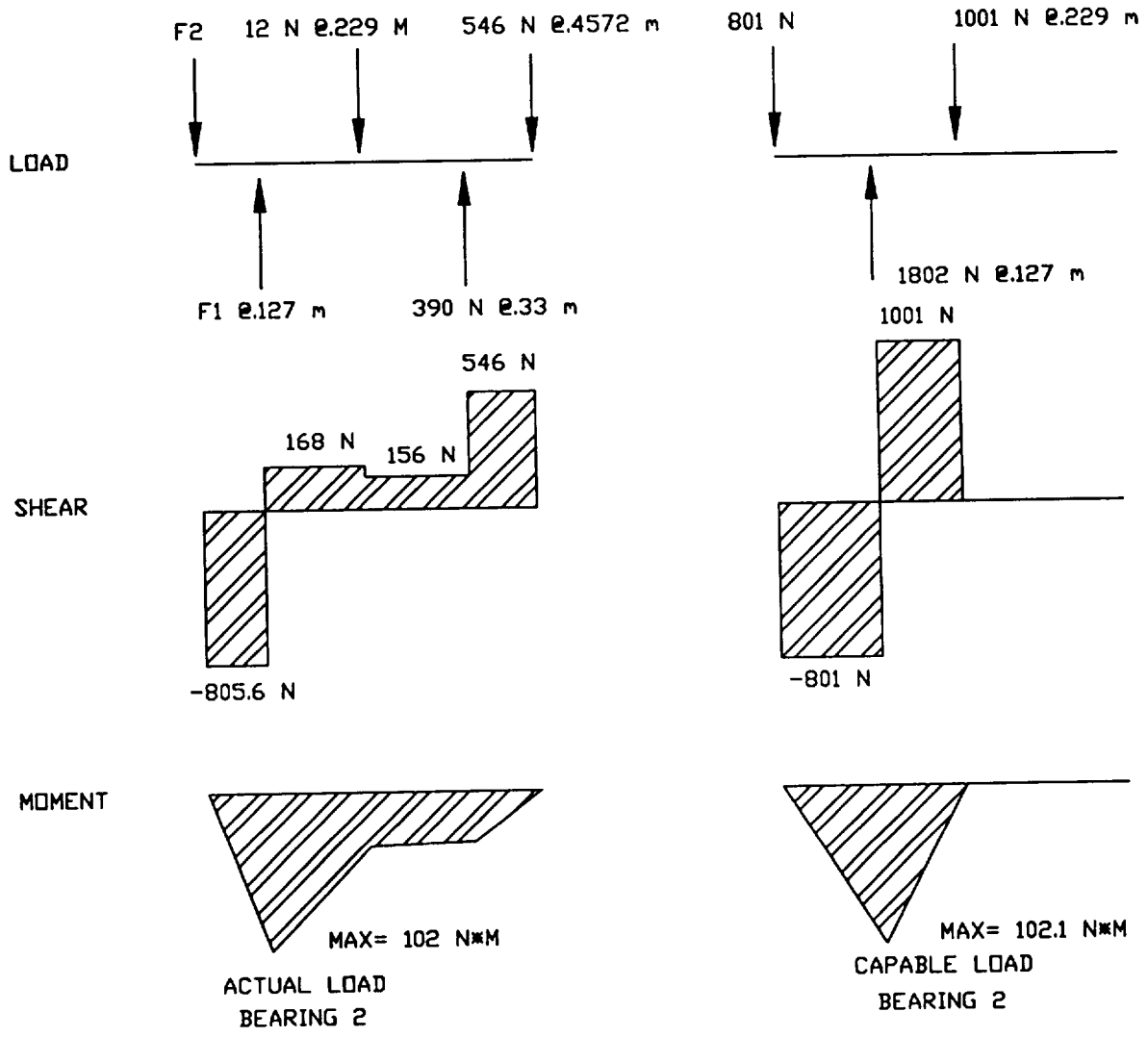

Figure 20.7.3.2 Shear/Moment Diagrams

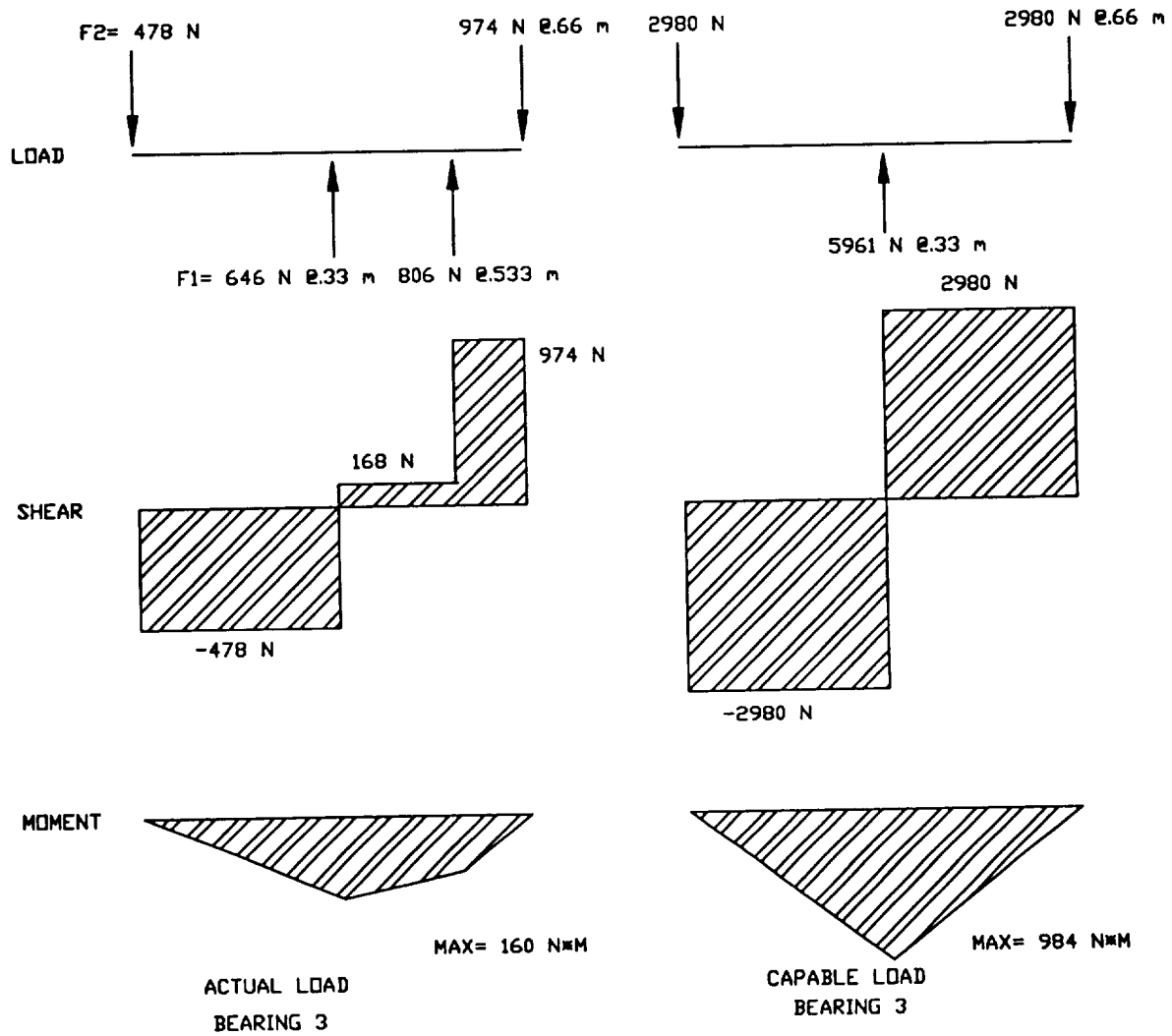

Figure 20.7.3.3 Shear/Moment Diagrams

26 weighs 133.5 N per pair. Further research and analysis may be necessary for other alternatives if these bearing weights are excessive.

Chapter 21.0 ACTUATOR

The following detailed summary is for an actuator system used in a telescoping robot. The robot is to be located in the CELSS chamber at Cape Canaveral Air Force Station. The actuator must have a minimum of 183 cm extension, while maintaining a maximum of 48.3 cm retracted length. The actuator must be able to extend a 15 kg end effector to the maximum length specified previously. The chamber is considered a clean environment, so the use of lubricants or any out-gassing materials is prohibited. This requirement eliminates the use of hydraulics and the requirement of 0.64 cm accuracy eliminated the use of pneumatics. The following design meets all the required specifications of the customer (NASA), while maintaining a low weight and cost.

21.1 TELESCOPIC ACTUATOR

The telescopic actuator idea was taken from the concept of an automobile's automatic antenna. It consists of five primary cylindrical tubes ranging from a diameter of 0.397 cm. to 1.03 cm. The actuator tubes are placed on the bottom front face of link one. The length of the telescopic actuator fully extended is 199.14 cm and fully retracted is 39.75 cm. The telescopic actuator links are manufactured out of steel. Between each primary tube there is a steel tube coupler. The purpose of the coupler is to act as stoppers to prevent over-extension or under-extension the tubes (Figure 21.1.1).

21.2 DRIVE MECHANISM

The drive mechanism drives a flexible steel braided cable through the telescopic links. This cable allows the actuator telescopic links to extend and retract. It consists of two steel pulleys which have dimples around the circumference to provide more friction to the cable. The first pulley is the drive pulley that provides an interface between the motor and drive cable. The second pulley provides an adjustable compression fitting to the cable to provide a positive drive force to extend the arm (Figure 21.2.1). From the drive pulley, a steel housing is installed to provide a path for the cable from the drive mechanism to the telescopic links.

21.3 TAKE-UP REEL

The purpose of the take-up reel is to house the cable when the actuator is not fully deployed. The take-up reel is a 7.5 cm diameter steel reel. A coil spring type mechanism located under the take-up reel provides self winding characteristics to the drive cable. The spring constant of this coil spring multiplied by the maximum extended distance of the cable must be less than the force developed by the drive wheels, or the actuator will not stay extended.

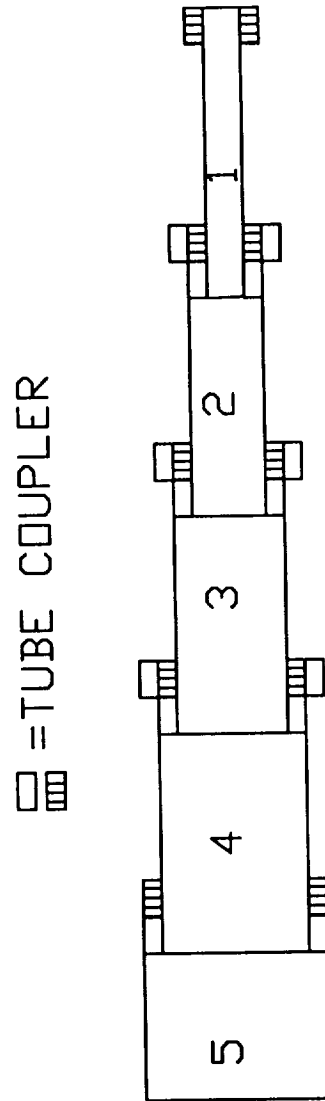

DRAWING NOT TO SCALE

Figure 21.1.1 Actuator Links and Couplers

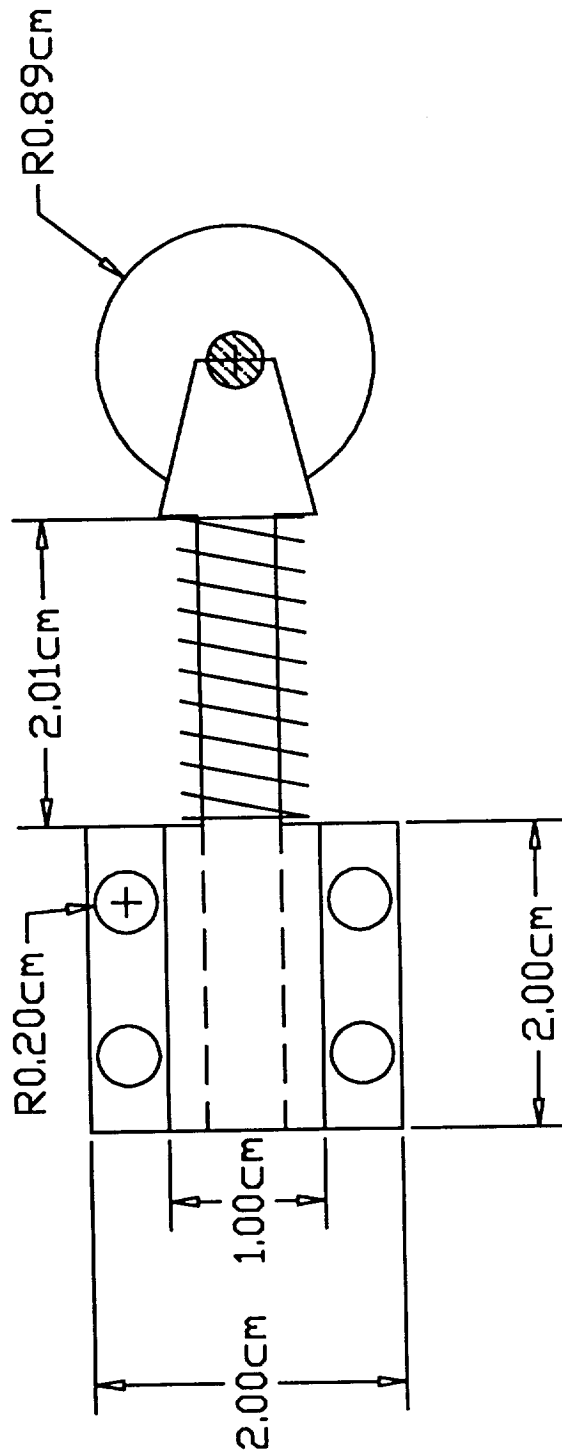

Figure 21.2.1 Compression Spring

21.4 INTEGRATION

The "floor" area for all the components of the actuator system was insufficient in link 4, so a steel plate raised on two blocks will be incorporated. The purpose of this block is to raise the actuator from link four into the interior of link three, thus providing more "floor" area to mount components. The drive mechanism and take-up reel are bolted to a 7.62 cm X 15.24 cm steel plate (Figure 21.4.1). The plate is mounted to 1.91 cm X 0.64 cm X 2.54 cm steel block. The end of the telescopic actuator is mounted to the bottom of the front face of link one. This is bolted to the link by cutting threads into the last 2.5 cm of link one on the actuator (Figure 21.4.2). All bolts used to integrate the actuator components are 3mm bolts, 16 or 32 threads per inch. All components are bolted for easy accessibility.

21.5 COST

The cost for the total actuator sub-system is estimated at \$600.00. The break-down of the approximate cost per component is as follows:

Tubes	\$70.00
Motor	\$300.00
Take-up Pulley	\$80.00
Drive wheels	\$135.00
Drive cable	\$11.00
JB Weld	\$1.00
3mm Bolts	\$3.00

21.6 WEIGHT

The approximate weight of the total actuator sub-system is 2.5 kg. The break-down of the approximate weight for each component is as follows:

Tubes	0.50 kg
Motor	1.40 kg
Pulleys	0.25 kg
Cable	0.35 kg

21.7 OBSERVATIONS AND RECOMMENDATIONS

The motor used to drive the actuator system needs to have a self containing gear reduction system. The motor needs to fit into the third link of the telescopic arm with a maximum height of 6.35 cm and a maximum diameter of 7.62 cm. If a motor fitting these dimensions and the specified requirements of the arm is not located from a vendor search, recommend a motor be mounted on the outside of the telescopic arm (link four). The

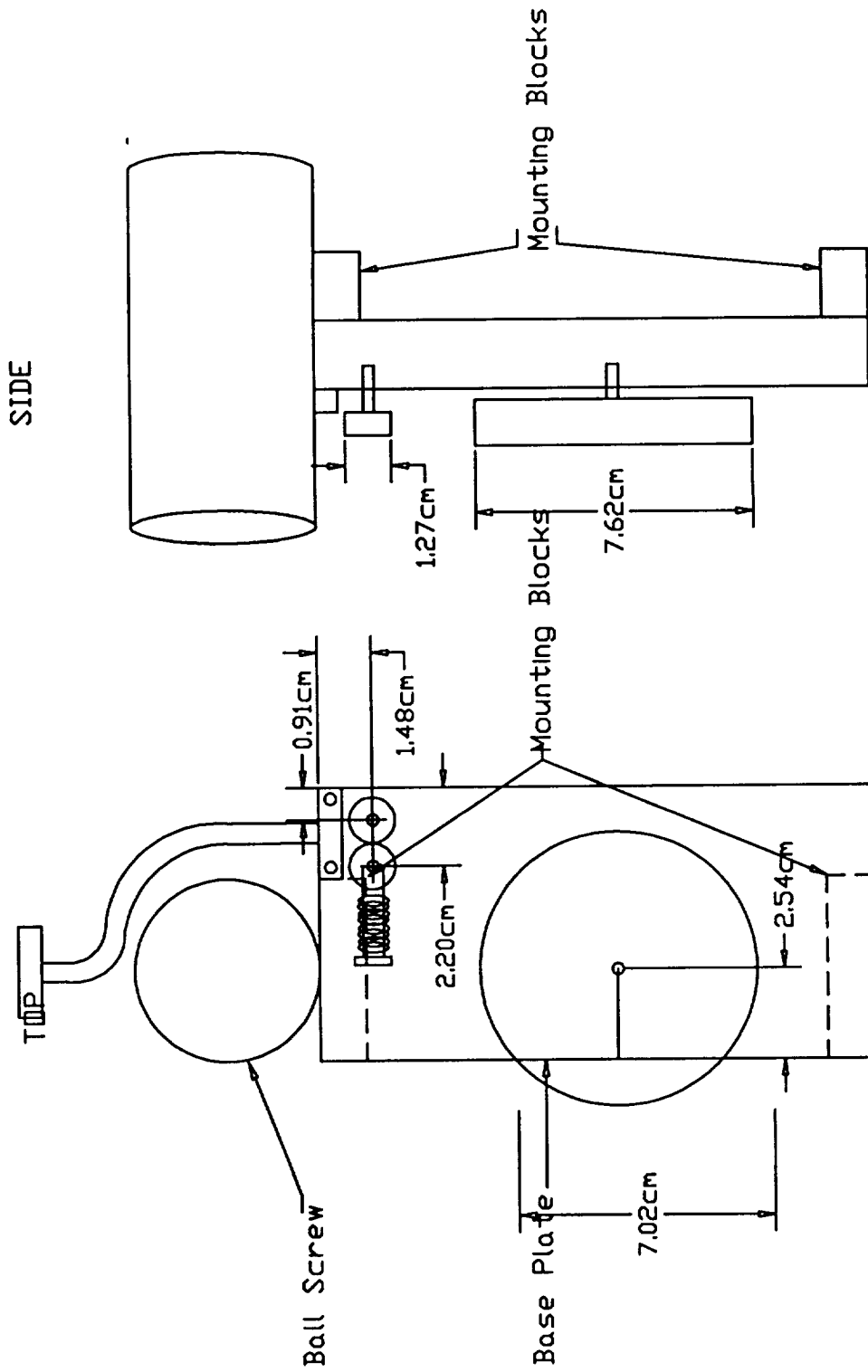

Figure 21.4.1 Actuate System

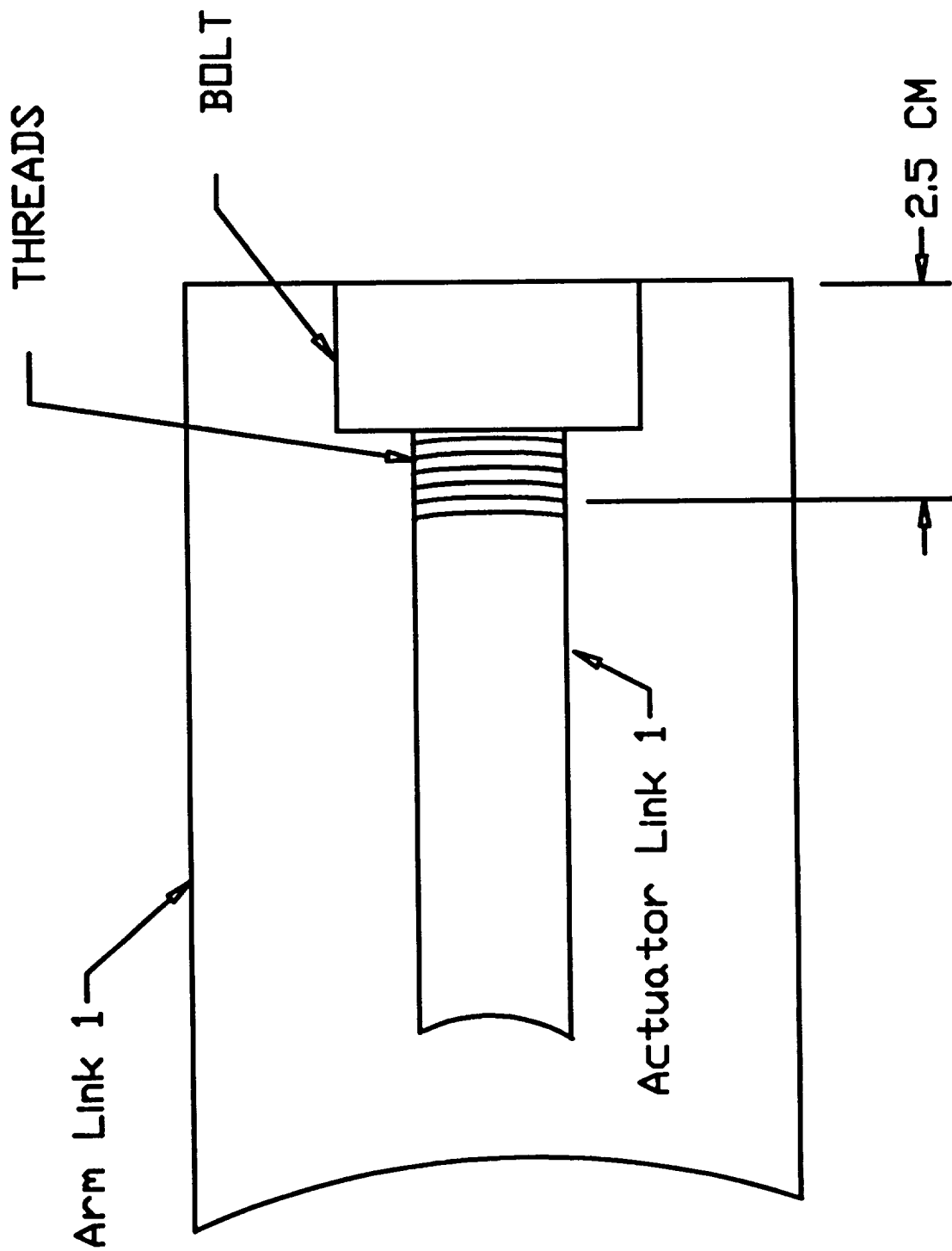

Figure 21.4.2 Actuator Locking Collar

drive cable needs to be flexible. Recommend it be made of a braided steel to provide stiffness as well as flexibility.

Chapter 22.0 SEQUENCING

22.1 INTRODUCTION

The CELSS robot arm consists of four telescoping links. The smallest link, link one, retracts into link two, the next larger link. Link two then retracts into link three, and link three retracts into link four. The order in which these links extend and retract involves a predefined order which was requested by NASA. The order of extension is link one first, followed by link two, and then link three. Link four is the main housing of the three other links and does not have any telescoping movement relative to the chamber. The order of retraction is also successive starting with link one, then link two, etc.

22.2 ROLLER BALL PLUNGER

The method of sequencing is accomplished by two roller type ball plungers. The roller ball plunger is a hollow piece of stainless steel with a threaded housing having one open end that has the ball protruding and the other being slotted for screwdriver installation and adjustments (Figure 22.2.1). Within the housing is a 302 stainless steel spring that provides pressure on a spherical ball made of Delrin. Delrin is a substitute for stainless steel which reduces wear caused by sliding contact with the links. The ball is restrained from falling out of the open end by a small flange. The threads on the housing contain a locking element made of Nylon 101 which holds the plunger assembly in a fixed place after installation and adjustments.

22.2.1 BALL PLUNGER SELECTION

Two parameters limit the selection of the roller ball plungers. The first requirement is the limited clearance between the links, which is the proposed location for the plungers (Figure 22.2.1.1). The clearance available for a plunger between link two and three is 9.25 mm (0.37 inch). The plunger for link three and four is not constrained because it can protrude through the surface of link four without hindering any motion of the robot arm (Figure 22.2.1.1). The second requirement is the force needed to hold link three in place. For proper sequencing, this force must be greater than the force required to hold link two. The data for the two plungers that best meets these requirements are listed (Table 22.2.1.1).

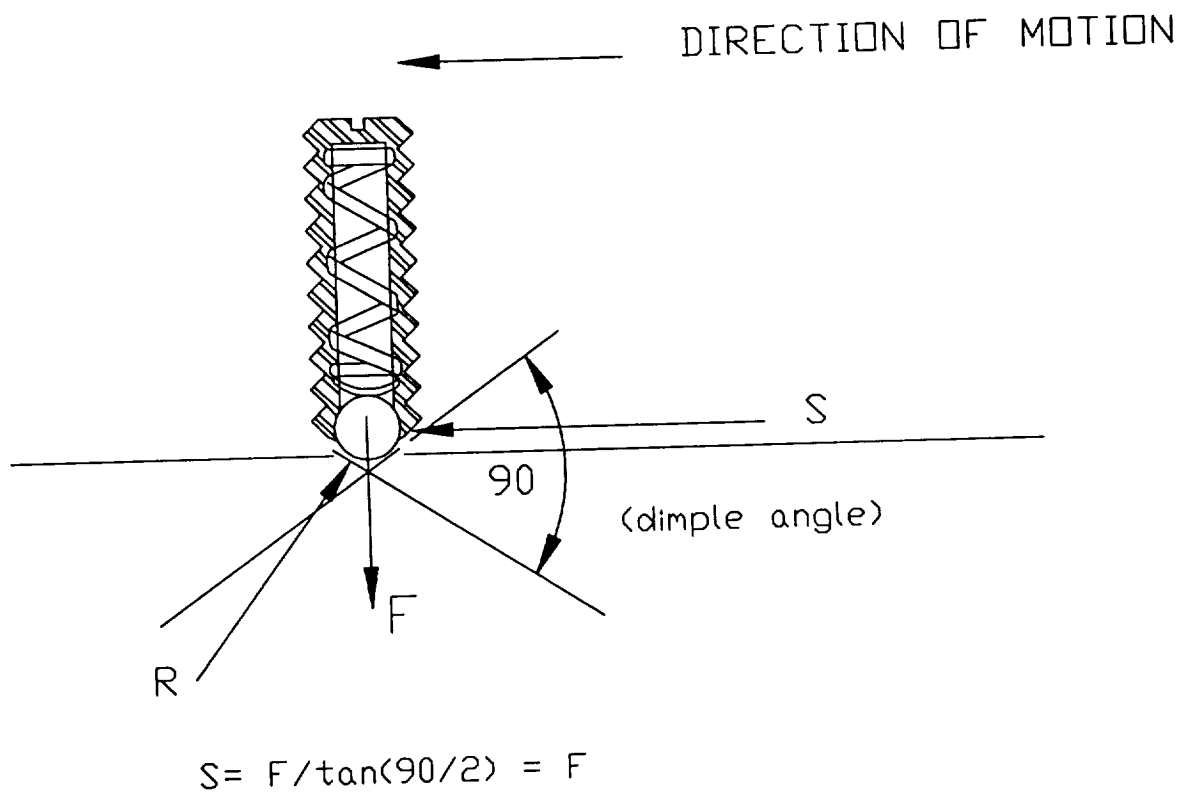

Figure 22.2.1 Plunger Force

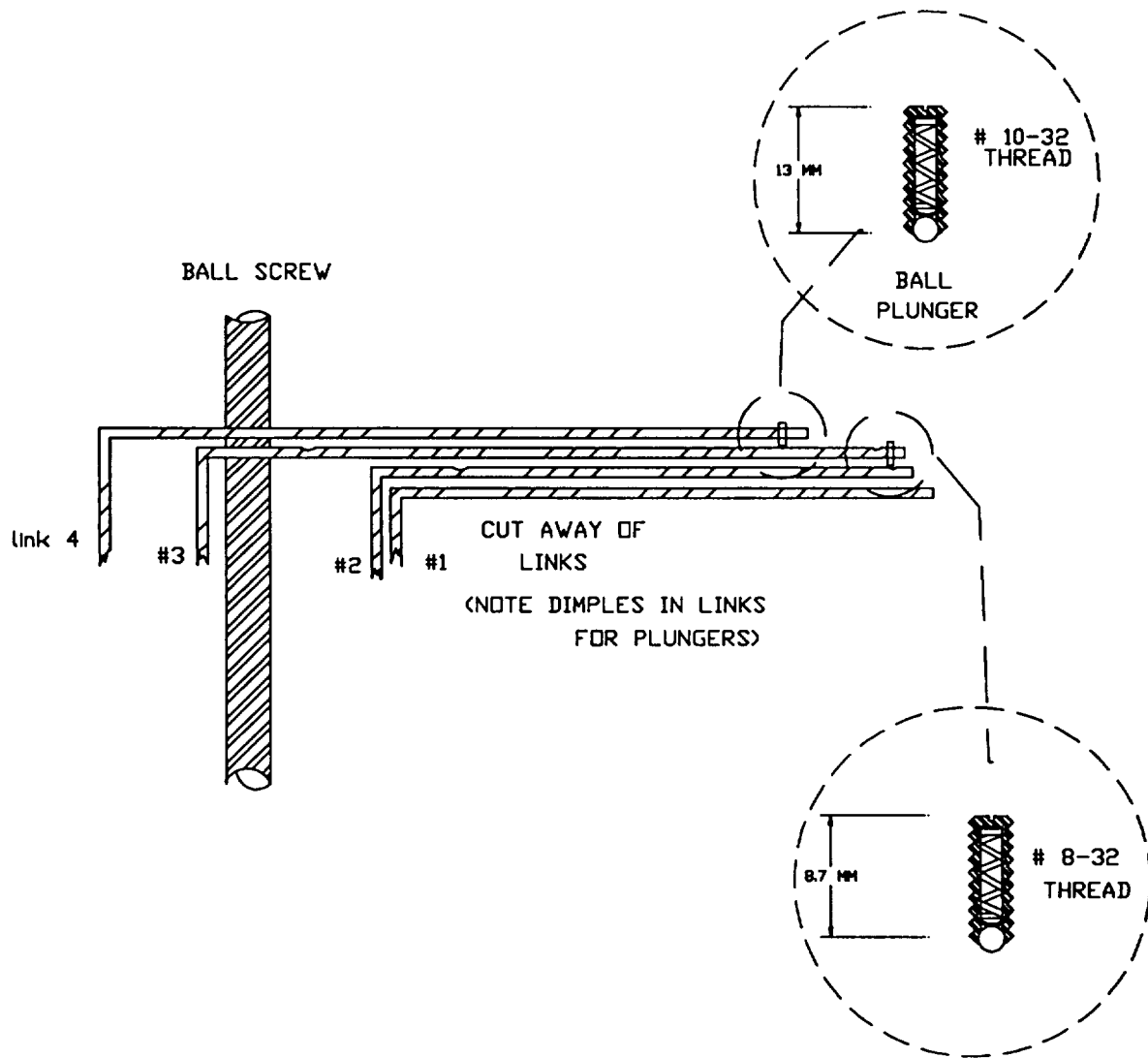

Figure 22.2.1.1 Plunger Orientation

Table 22.2.1.1 Plunger Specifications

	<u>Link 2-</u> model 1	<u>Link 3-</u> model 2
Threads	#8-32	#10-32
Force Range *	0.50-1.25 lbs.	2-5 lbs.
Height of Tube	0.344 in.	0.52 in.
Ball Extension Length	0.025 in.	0.025 in.
Diameter of Ball	0.093 in.	0.093 in.
Part Number	CL-22-SBPN-1	CL-30-SBPN-3

* Note the force ranges on each model. The forces get larger as the spring inside the assembly is compressed. This spring compression is achieved by screwing the plunger housing in (clockwise).

22.3 SEQUENCING BY PLUNGER MECHANISM

22.3.1 On the robot arm, there are ball bearing slides on either side of links 1, 2, and 3. These bearings provide a near frictionless sliding track on which the link travels. Due to this low friction track, the small forces exerted by the ball plungers are effective.

22.3.2 Ball Plunger Installation

- 1) Drill and tap the #10-32 threads 1.27 cm from the end furthest from the ball screw shaft in the location indicated (Figure 22.2.1.1).
- 2) Screw in the ball plunger with a regular head screwdriver.
- 3) Adjust the force on the roller bearing plunger by screwing the plunger in closer to link 3, for greater force, or further out from link three, for a weaker force.
- 4) At the maximum arm extension and maximum retraction, drill 90° dimples (Figure 22.2.1) approximately .03 inches deep to serve as the seat for the ball plungers at the proper location (Figure 22.2.1.1).
- 5) Follow steps 1 through 4 for the installation of model #1 to link three.

22.3.3 Sequencing

The ball plungers provide the following sequencing: Starting with all links in the fully retracted position, the plungers on links two and three are engaged into their respective dimples. When the actuation starts, the smallest link, link 1, extends first because it does not have the additional force of a ball plunger acting on it. Once link one is fully extended, Link 2's ball plunger, model 1, disengages from the dimple due to the force caused by link 1 because it requires a smaller force than the model two plunger (Table 22.2.1.1). The fact that the links get successively heavier also assists in the proper sequencing. Once link two is fully extended, the ball plunger locks into the dimple at the fully extended position and further force will cause the plunger in link three to disengage allowing extension of link three. When link three is in its fully extended position, the

model 2 plunger engages into its locking dimple. Since both of the plungers are now engaged in the robot arm's fully extended position, sequencing for the retraction of the arm is the same as in the extension with link 1 being the first, then link 2 and finally link 3.

22.4 VENDOR

Carr Lane Manufacturing Company
4200 Carr Lane Court
P.O. Box 191970
St. Louis, MO 63119-2196
Phone:(314) 647-6200
Fax:(314) 647-5736

22.5 OBSERVATIONS AND RECOMMENDATIONS

- 22.5.1 The proposed sequencing will not work correctly without proper location of the dimples. Without proper location of the dimples, the ball plungers will not provide the resistance needed for sequencing.
- 22.5.2 The adjustments of each plunger must be adequate to provide the resistance needed for proper sequencing.
- 22.5.3 Any type of resistance application will work for sequencing as long as link one has the least resistance and link three has the most resistance.
- 22.5.4 A trial run can be made without any external sequencing devices to see if sequencing order in the robot arm is self induced. The reason is attributed to link one being the lightest, and thus having the least friction from it's bearings. Link two should sequence next for the same reason, and then link three.

Chapter 23.0 BELLOWS

23.1 Introduction

A bellow is a covering which protects the local environment from the system or component it encloses (Figure 23.1.1). Several different types of bellows were considered for two components of the CELSS chamber, the central shaft and the robot arm. The use of bellows protects the CELSS chamber from foreign substances which leak from the robot such as lubricants used for the arm bearings or central shaft bearings or metal shavings which may be produced from wearing of different components. In addition, the bellows also provide protection to the robot from the CELSS chamber. The bellows safeguard the mechanical components of the robot from the humid environment of the CELSS chamber preventing corrosion and other hazardous effects related to

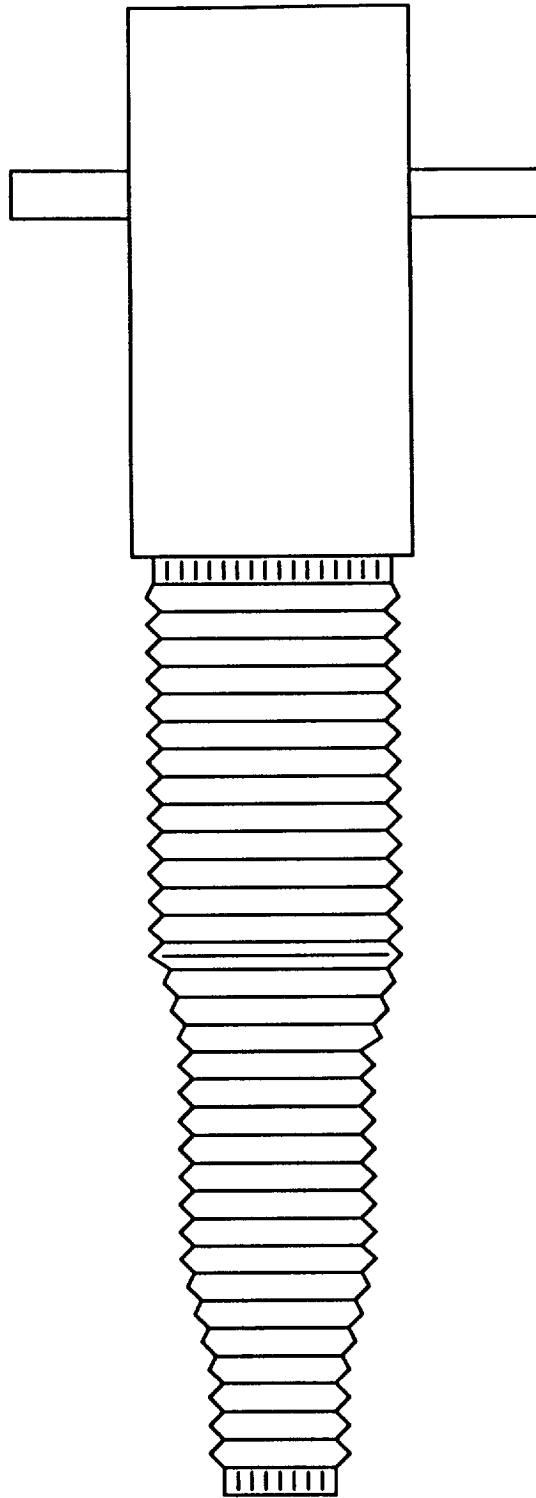

Figure 23.1.1 Extended Tapered Bellows

moisture in the chamber. The bellows also protect against microscopic particles produced from the vegetation such as grain dust, pollen, dirt and other air borne substances present when cultivating food crops.

23.2 OPERATIONAL EFFECTS

23.2.1 Central Shaft Bellows

The greatest problem installing the bellows on the CELSS robot is the reduction of the work envelope. The bellows considered, Stock Sewn Bellows by Centryco, collapsed to a length of 2.03 cm for every 30.5 cm of extended length. As shown in Figure 23.2.1.1 two bellows are needed for the central shaft, one above and below the robot arm. The arm is restricted from reaching the top or the bottom of the shaft due to the space required to accommodate the collapsed bellow shown in Figure 23.2.1.1 For two 2.44 m bellows on either side of the arm, 16.3 cm of space is required to house the collapsed bellow in addition to 10.2 cm required for the collar of the bellow. That translates to losing 26.4 cm of vertical length from the top of the central shaft and 26.4 cm from the bottom, a total loss of 52.8 cm in the vertical direction.

23.2.2 Tapered Arm Bellow

The bellows used for the robot arm, also a product of Centryco, is a tapered type to properly fit the telescopic arm. Although the robot arm bellow collapses into itself more than the central shaft bellow because of its tapered geometry, it requires 1.27 cm of collapsed space for every 30.5 cm of extended length and 10.3 cm for the collar as shown in Figure 23.2.2.1. The additional 18 cm needed for the retracted bellow further reduces the work envelope of the robot.

23.3 OBSERVATIONS AND RECOMMENDATIONS

Bellows are an important tool which may be used to protect the CELSS chamber from the contaminants produced by the robot arm. They may also be used to protect the robot arm from the environment of the CELSS chamber. The major obstacles in using bellows are the effects they have on the reachability of the robot in the vertical direction and the increased collapsible length of the robot arm due to the collapsed bellows. There is a trade off between the protection of the robot arm and the CELSS chamber, and the reachability and collapsibility of the robot. Further investigation of different types of bellows is recommended. A bellows that does not interfere with the working envelope of the CELSS robot or one that collapses to a smaller length may be found.

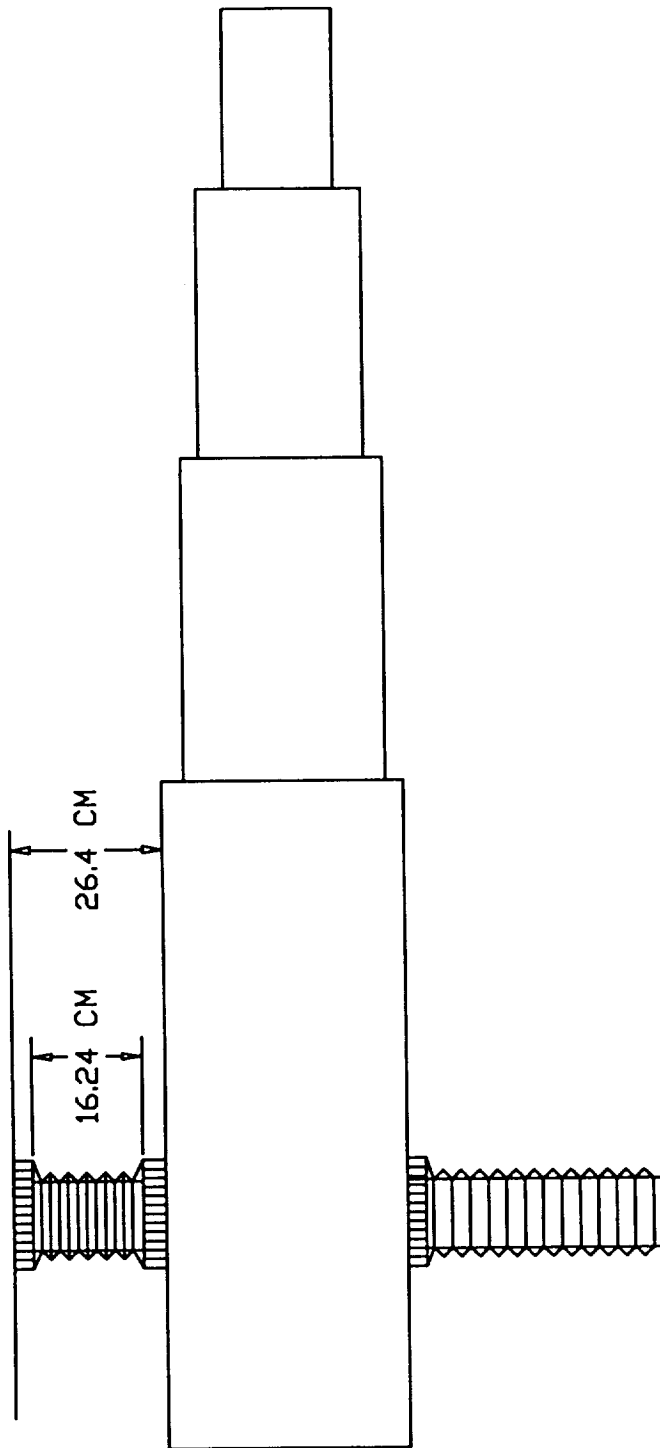

Figure 23.2.1.1 Central Shaft Bellows

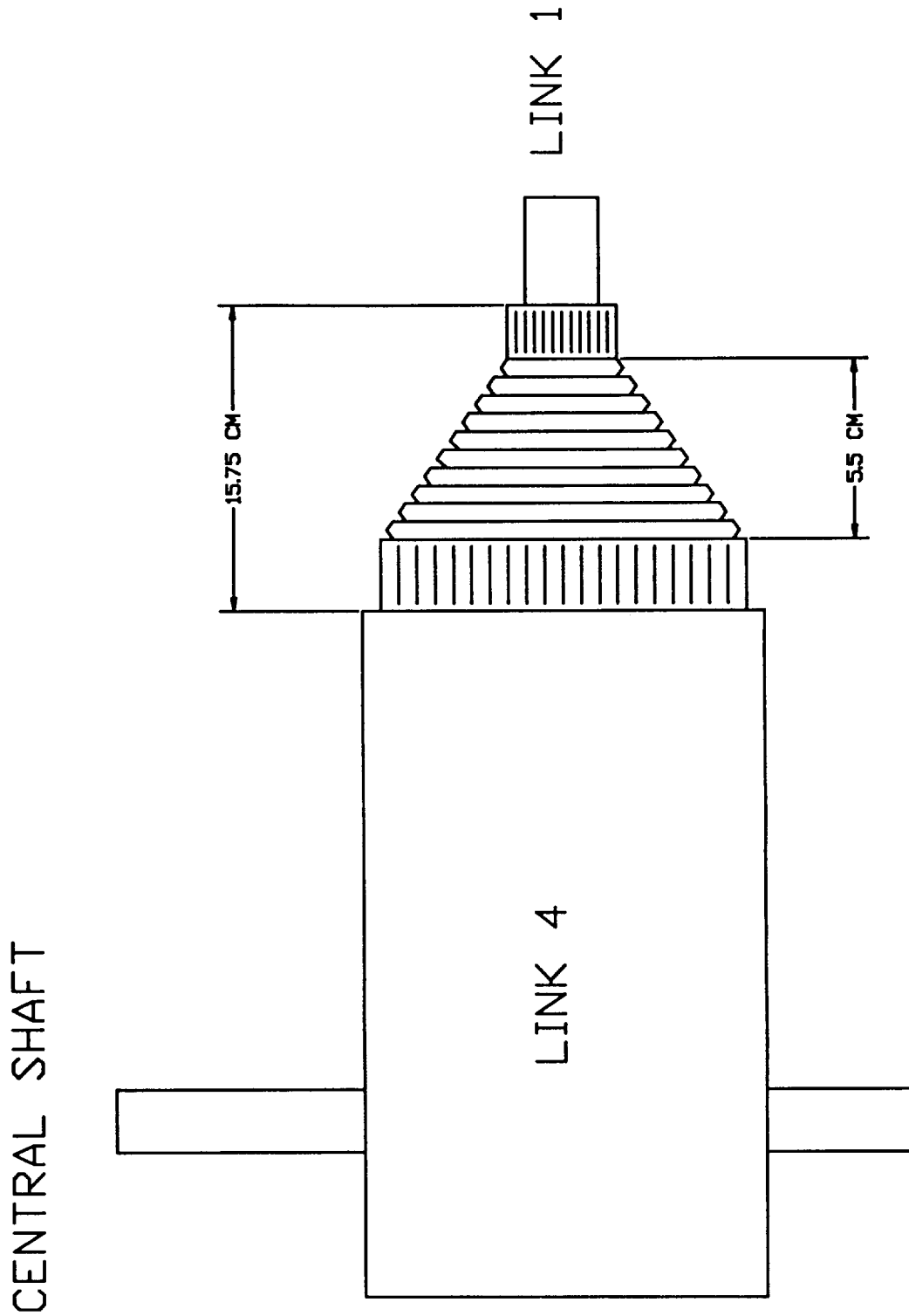

Figure 23.2.1 Retracted Tapered Bellows

Chapter 24.0 DUAL "V" GUIDE SYSTEM

24.1 INTRODUCTION

The Dual "V" Guide system functions as a mounting structure between the telescopic boom and the Central Mounting Structure (Figure 24.1.1). Besides providing a stable support, the system allows the telescopic boom to rotate around the ball spline shaft which is essential to reach the entire circumference of the working envelope. This capacity of rotation is provided by eight precision guide wheels (Figure 24.1.2).

This system consists of the following components:

- Steel tracks
- Precision guide wheels
- Internal gear
- Adjustable adapter bushings
- Spur gear

The selection of this system was based on the following advantages:

- Easy mounting to machined surfaces
- Self cleaning feature due to the circumference being greater at the edge than it is on the bottom of the "V" groove, and there is constant wiping action present.
- The eccentric bushings provide the means to take out "slack" and compensate for any inaccuracy or accumulation of tolerances.
- The cost is attractive in comparison with the previous turn-table bearing proposal.
- All the components are commercially available in a wide selection of sizes and materials. This availability allowed an economical choice that could meet the load requirements and space constraints.

24.2 STEEL TRACKS

The circular steel tracks are machined with a 90 degree "V" cross-section on one side and a flat surface on the other. The "V" cross-section serves as a track for the precision guide

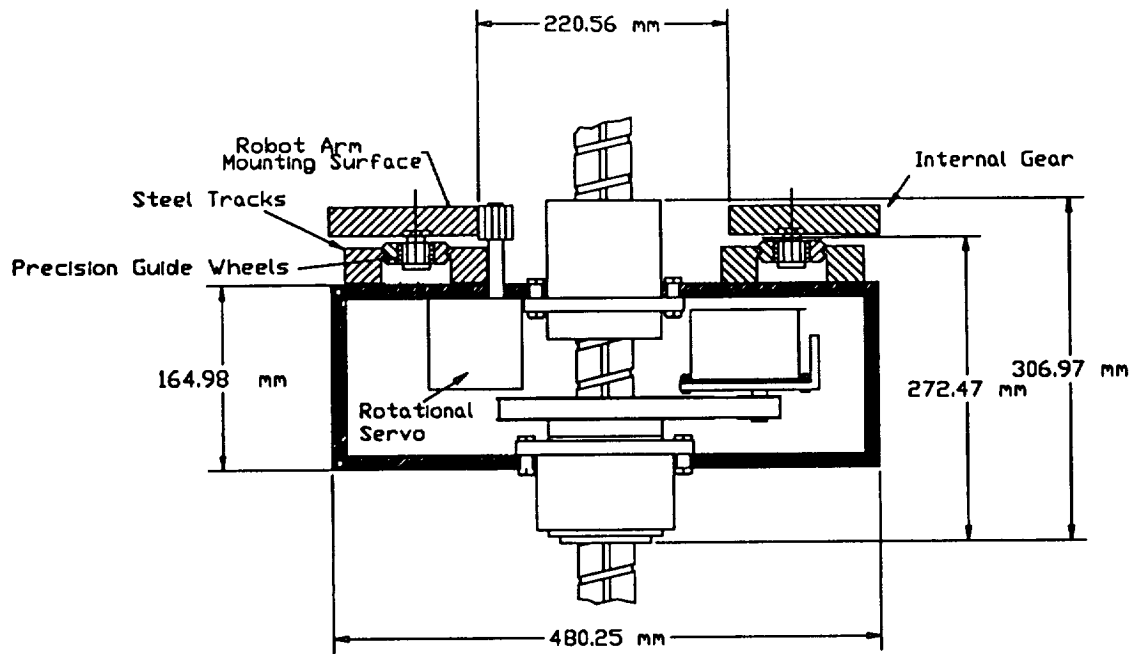

Figure 24.1.1 CMS with the Dual "V" Guide System Depicted

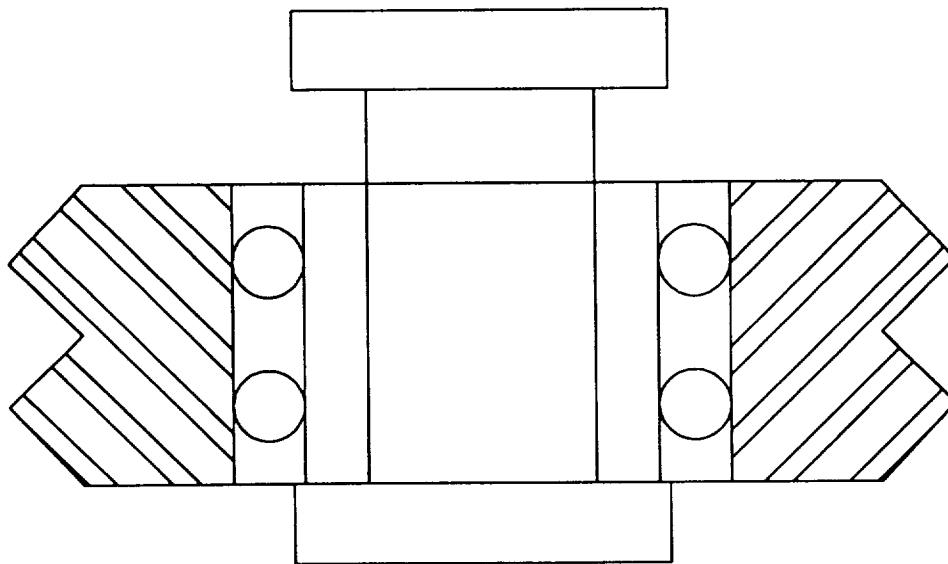

Figure 24.1.2 Precision Guide Wheel

wheels to travel on. Furthermore, the circular tracks provide stability with the added feature of providing maximum available working area unobstructed by the ball spline shaft.

Material: C1042 Cold Formed Steel, contact edge flame hardened to RC53.

24.3 PRECISION GUIDE WHEELS

The precision guide wheels provide a stable and rigid interface between the steel tracks and the telescopic boom. At the same time, the guide wheels serve as friction reducers allowing the telescopic boom to rotate around the ball spline shaft. The guide wheels are attached directly to the internal gear and inserted between the tracks. The materials are fabricated of the following:

Wheels: 440C Stainless Steel, hardened to RC60-62 with ground contact edges

Bearings: Stainless Steel; sealed and pre-lubricated; thus preventing outgassing into the CELSS chamber.

24.4 INTERNAL GEAR

The internal gear is part of the rotational actuator mechanism and it is attached to the bottom of the telescopic boom. A pinion attached to the rotational actuator electric motor is engaged with the internal gear to produce the rotation of the telescopic boom.

24.5 SPUR GEAR

The spur gear is actuated by the electrical motor mounted within the Central Mounting Structure. The spur gear is the actuator for the system. It engages the internal gear and provides for the rotational movement.

24.6 DUAL "V" GUIDE SYSTEM ANALYSIS

The accuracy of the wheel and track system depends on the circular tracks being parallel. Therefore it cannot be stressed too strongly reasonable care should be taken when bolting the tracks to the top plate of the central mounting structure to assure proper alignment. There are eight evenly spaced guide wheels to ensure the leverage of the fully extended arm with a 15 kilogram weight does not cause stresses exceeding the load capacity of the wheel.

24.6.1 Steel Tracks

The steel tracks are specially made in a machine shop. Holes must be drilled to securely bolt the internal gear. The eight holes are evenly spaced.

24.6.2 Precision Guide Wheels

There are eight guide wheels evenly spaced in the assembly to provide 360 degree rotation. The rating provided for average life of the precision series guide wheels is 2500 hours. The system life is 2 years based on the assumption the robot will have 3.25 total hours of operation per day. The internal bearings are sealed and lubricated with a thin oil thus preventing any contaminations to the CELSS chamber.

24.6.3 Internal Gear

The internal gear will have a 14.5 degree pressure angle with 32 pitch teeth. The inside diameter is 6.00 inches and the outside diameter is 6.75 inches.

24.6.4 Spur Gear

The gear ratio for the internal and spur gear has not been determined. The calculations provided in Annex C must be revisited with the current data from this system.

24.7 OBSERVATIONS AND RECOMMENDATIONS

The accuracy of the system depends on the mounting surfaces being parallel; therefore, care should be taken when bolting the steel tracks to the mounting surface to ensure proper alignment.

The deflection of the "V" Guide System was not determined. As indicated above, the degree of tolerance on the concentric tracks plays an important role in determining the tolerance.

The precision guide wheels are spaced to ensure the moment created by the over-hanging loads, produced by the fully extended arm, does not create stresses exceeding the load capacity of the guide wheels.

The use of adjustable adapter bushings is recommended over the stationary bushings due to their ability to compensate for inaccuracies of installation and/or the accumulation of tolerances.

All components of the Dual "V" Guide System are stock items except the tracks. The tracks must be fabricated. The total cost of the precision guide wheels is \$549 (Table 24.7.1).

Several pre-tests are recommended in the assembly of the "V" Guide System. In fabrication of the tracks, the tolerances must meet specifications.

The installation of the system will involve accurately mounting both the "V" guide tracks to the CMS as well as mounting the guide wheels to the underside of the telescopic boom. There must be a method to install the guide wheels in the track. One possible solution is to fabricate a slot in the external track which the guide wheels can be inserted one at a time to a mounting plate. The mounting plate is then bolted to the telescopic boom.

The purpose of designing the Dual "V" Guide System is to provide a lighter and a more economical alternative than the turntable bearing. The Dual "V" Guide System is both lighter and less expensive and meets all required specifications (Table 24.7.1).

Table 24.7.1 Price and weight comparison

System/Components	Weight	Price
1) Turntable Bearing	18 kg	\$ 1,500
2) Dual "V" Guide System		
Steel Tracks	5.13 kg	\$???
Precision Guide Wheels	2.29 kg	\$ 549
Internal Gear	0.53 kg	\$ 100
Adjustable Adapter Bushings	0.33 kg	\$ 52
Spur Gear (Pinion)	0.05 kg	\$ 20
Total	8.33 kg	\$ 721

Chapter 25.0 CABLE REEL DESCRIPTION

25.1 INTRODUCTION

The cable reel subsystem provides electrical/control power to the robot arm system. It has the capability of delivering power to the system as the robot moves vertically inside the chamber. The cable reel system (Figure 25.1.1) consists of a spring retraction system capable of taking in slack cable as the robot arm moves vertically. Although a clutch is available for the cable reel model series it is not used for automatic payout and retrieval of the cable. A cable stop is used to prevent damage to cable fitting and to permit

SPRING REWIND CABLE REEL OVERALL DIMENSIONS

MODEL #
NARROW-FRAME SERIES
NSCR716-16-17J
HANNAY REELS

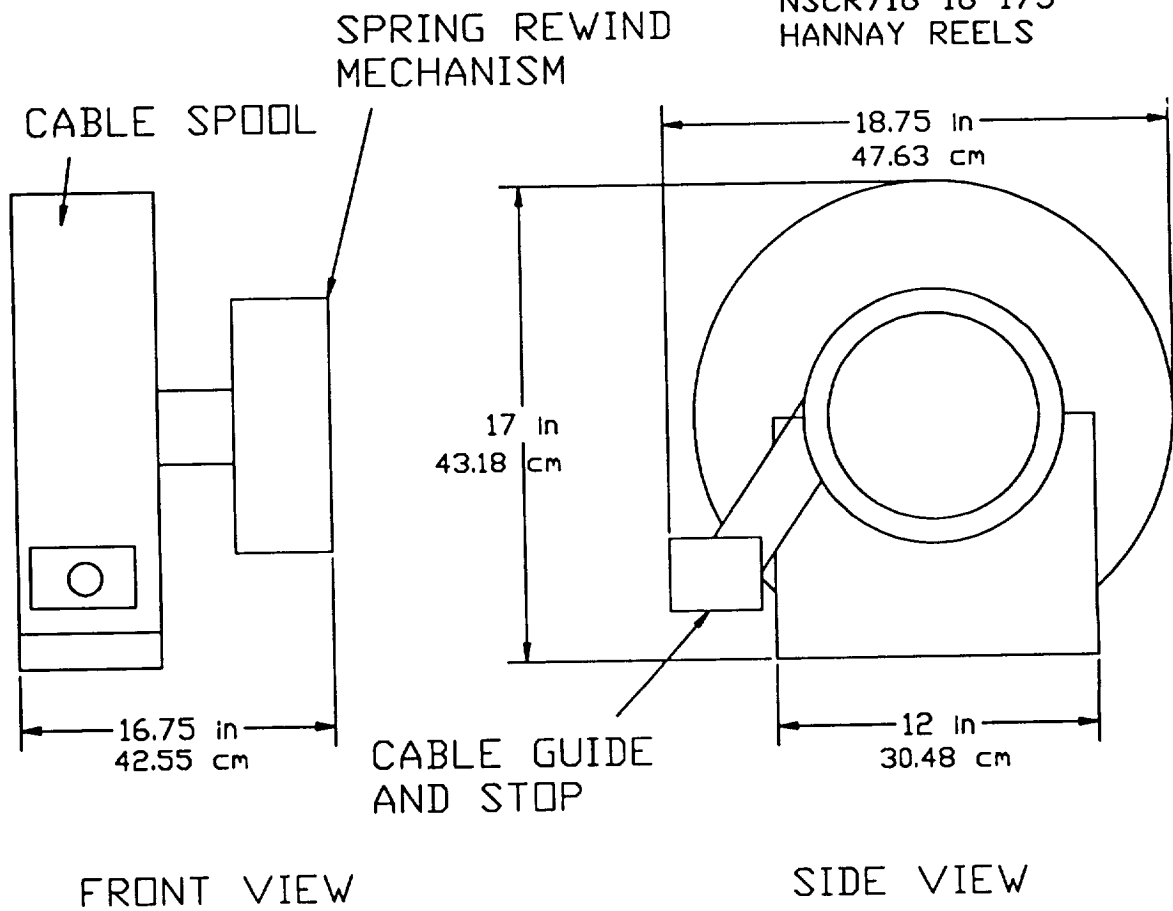

Figure 25.1.1 Cable Reel System

adjustment of free cable length. The automatic recovery/pick-up system ensures that slack cable does not interfere with operation of the robot.

25.2 CABLE REEL

The cable reel is mounted on the chamber wall to the left of the door (Figure 25.2.1). The reel is offset 1/2" from the stowed shaft position. The vertical position of the cable reel is as close to the floor as possible but also is in a position that won't interfere with normal chamber operations. The cable runs from the cable reel down the chamber wall and along the floor to a position directly below the central mounting structure of the robot. The cable is guided with (3)U-bolts, to ensure correct positioning of the cable. The first on the chamber wall at the base of the wall, one on the chamber floor one inch from the wall and a third on the chamber floor below the central mounting structure.

The cable reel selected is the Hannay Reels narrow frame series NSCR model number NSCR716-16-17J, with roller position VR. The reel measures a maximum of 17" X 18 3/4" X 16 3/4". The empty weight of the cable reel is approximately 60 pounds. This model is capable of handling three conductors of gauges ranging from 16 to 8, and cable length from 40 to 45 feet.

25.3 OBSERVATIONS AND RECOMMENDATIONS

Placement of the cable reel in the chamber is not critical and can be left up to the end user. Use of a smaller cable reel is recommended if one is available. Prior to making a final selection consult the Hannay Cable Reel catalog to ensure compatibility with desired number of conductors and wire gauge.

Chapter 26.0 BALL SCREW INTERFACE PLATE

26.1 INTERFACE PLATE

A 17.15 X 30.48 cm stainless steel plate with a hollow steel cylinder is used to mount the ball screw to the carriage (Figure 26.1.1). The cylinder is hollowed to accept the 3.2 cm shaft end. The plate is fastened to the carriage at four bolt holes located at the corners of the plate. Two Norvell LP-401 stainless steel locking pins, each 10 cm in length and 1.27 cm in diameter, are used to fasten the shaft to the interface plate. The pins are inserted through the hollow cylinder and shaft at right angles to each other for stability. This allows easy removal of the shaft for maintenance.

Stainless steel alloy 304CD is used for fabrication of the interface plate. This alloy displays excellent corrosion resistance in all natural atmospheric environments and many artificial ones.

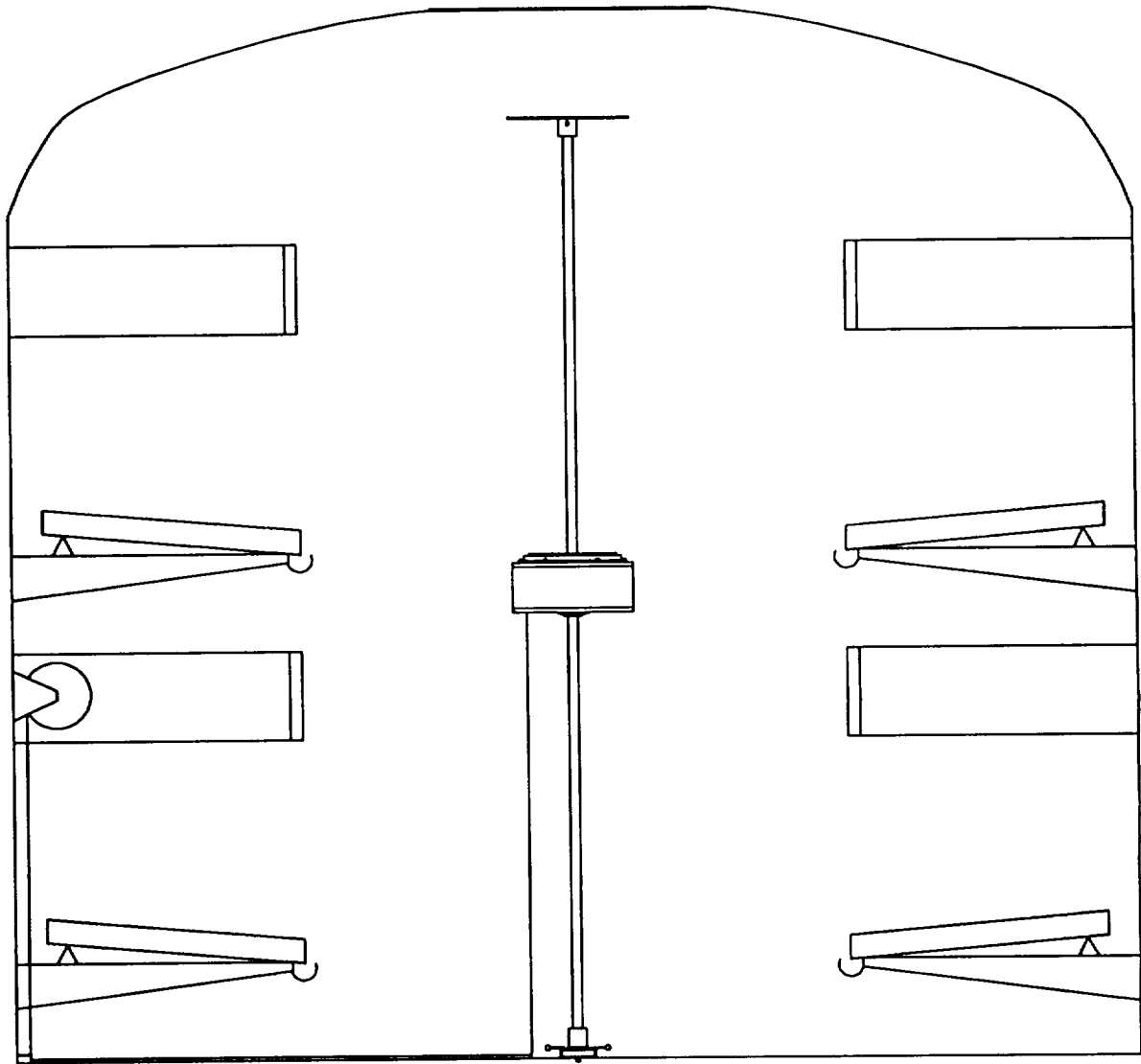
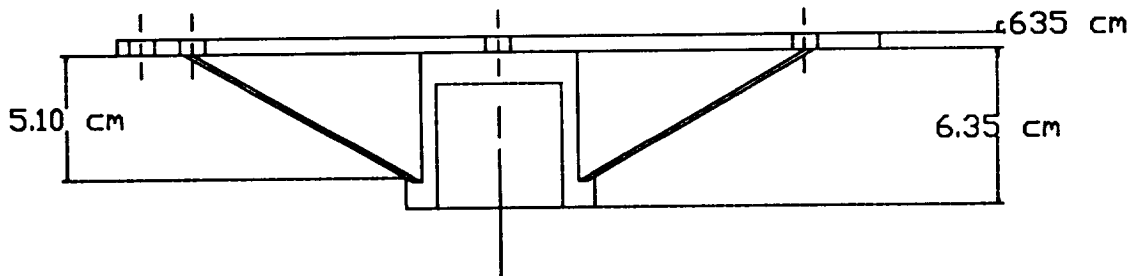
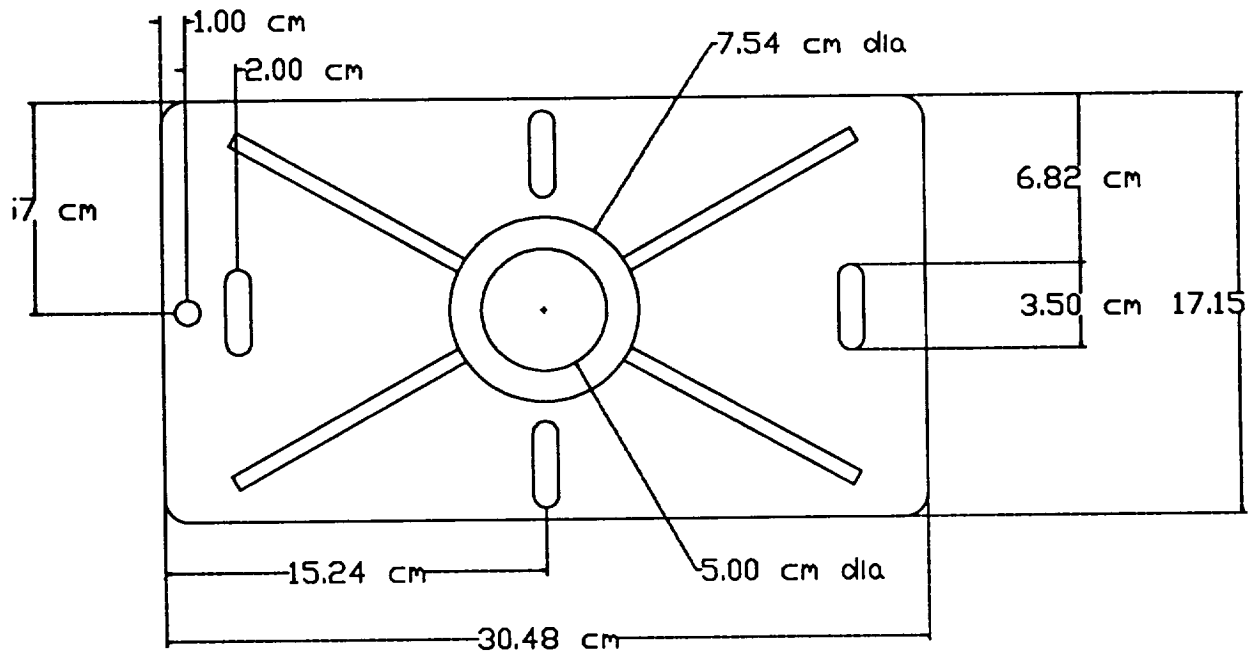

Figure 25.2.1 Cable Reel Placement



INTERFACE PLATE

Figure 26.1.1 Interface Plate

To provide lateral flexibility of the deployment position, the four bolt holes on the interface plate are slotted to 2.5 cm in length. This permits the bolts to be fastened at any point along the slot length, permitting exact fine tuning of the robot position in the direction perpendicular to the rail.

26.2 REMOVAL PLATE

A 15 X 15 cm stainless steel plate with a 9 cm ID cylinder (Figure 26.2.1) is used for removal of the shaft for maintenance. The cylinder is stainless steel with a wall thickness of .5 cm and an interior depth of 10 cm. The top of the cylinder is welded flush with the top surface of the plate so the center of the cylinder is at the center of the plate. The top 2 cm of the cylinder is threaded to accept a removal plate cap (Figure 26.2.2). The removal plate cap is a 12 cm diameter stainless steel cylinder with a 2 cm depth. The cap keeps debris from entering the removal cylinder when not in use.

The plate is positioned in the chamber so the center of the cylinder is directly below the center of the shaft when the robot is in the stowed position. Modifications to the CELSS chamber are needed to accept the removal plate. The plate is welded to the chamber on all sides. The welds must not exceed .5 cm in width.

26.3 BRAKING MECHANISM

A braking mechanism is necessary to hold the robot at a stable vertical position during deployment of the telescoping arm. The mechanism must also lock the robot in place on the shaft when the power to the system is shut off. An off the shelf, stand alone braking mechanism is available to accomplish this task. After research into possible methods of braking, a motor utilizing an internal brake was selected. This internal brake holds the motor shaft in place when the motor is not in use. In the previous design, a belt was used to transmit power from the motor to the ball screw actuator. When using an internal motor brake, the belt cannot be used. If the belt were to break, the internal brake would not hold the robot in place. If a solid gear is used to transmit the power to the ball screw actuator, there is a solid connection and no such failure can occur.

26.4 OBSERVATIONS AND RECOMMENDATIONS

As previously designed the robot system weight produces a large amount of torque. A motor with an internal brake capable of producing enough torque to adequately move the robot and fit in the volume required by the design was not found. With the redesign of the system, a decreased weight requires a smaller motor which fits within the actuator housing. If a volume constriction still hampers the sizing of the motor, a beveled gear may be used instead of the spur gear motor-actuator connection. This allows a larger motor positioned horizontally instead of vertically.

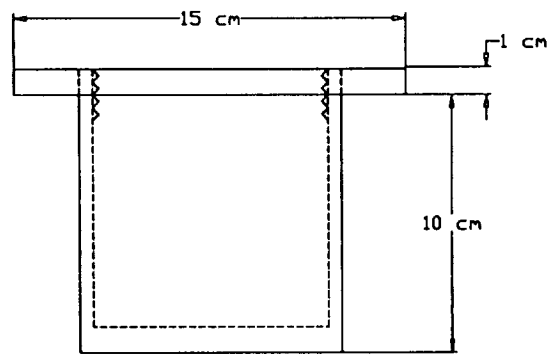
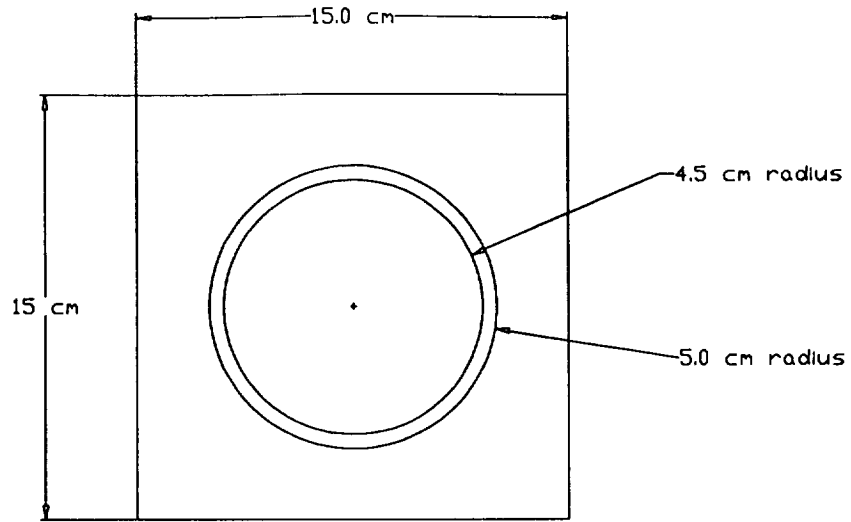

Figure 26.2.1 Removal Plate

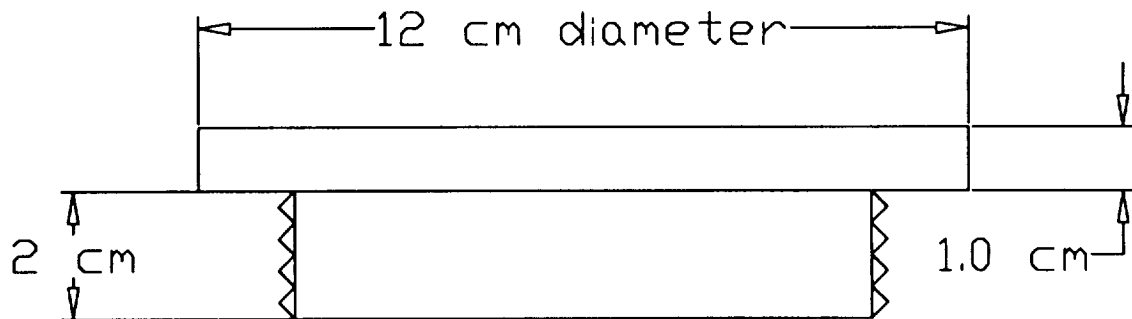

Figure 26.2.2 Removal Plate Cap

Chapter 27.0 STRESS AND DEFLECTION ANALYSIS

27.1 INTRODUCTION

The stress and deflection analysis of the CELSS chamber robot arm system consists of a computerized finite element analysis verified through standard engineering calculations of deflection and bending stress in a cantilever beam for the arm model, and the method of deflection by integration, and stress on a shaft for the shaft/arm assembly. The system was modeled in the worst case scenario to ensure structural integrity in all operational conditions.

27.2 I-DEAS COMPUTER ANALYSIS PROGRAM

The modeling and analysis of the CELSS chamber robot arm system was done using I-DEAS, Integrated Design Engineering Analysis Software. This software package uses a concurrent engineering approach to mechanical engineering analysis. The finite element modeling and geometry functions of the software are used to calculate deflections and stresses due to loading.

The package was used to create a solid model of the telescoping arm and a finite element model of the ball screw/ball spline vertical shaft/arm configuration. The solid model of the robot arm was created to determine the properties of the arm including the mass and center of gravity. The finite element model of the ball screw/ball spline shaft was used to determine the values of stress and deflection during operation. The finite element model of the arm was used to determine the values of stress and deflection under loading. These loads included the weight of the arm, the weight of the arm, the weight of the bearings, and maximum allowable load at the end of the arm.

27.3 MODELING DESCRIPTION

The vertical ball screw/ball spline actuator was first modeled as a solid steel shaft with a pin support at both the bottom and the top of the shaft and a bending moment (consisting of the moment created by the load, and the moments created by the weight of the arm and the weight of the bearings) applied to the midsection of the shaft. These boundary conditions best resemble the actual configuration of the system allowing restriction of movement in the x, y, and z directions at both the bottom and top pin supports and free rotation at both locations. This configuration models the shaft with the best possible support system, and the worst possible loading location in terms of deflection, thus, it is sufficient for the purposes of our analysis. The telescoping arm of the system was modeled as simple beam with different cross sectional areas to represent each link.

27.4 RESULTS OF COMPUTER ANALYSIS

A complete summary of the results from the I-DEAS analysis is given in Appendix L.

27.4.1 Results of Shaft Analysis

The results of the computer analysis performed on the shaft with 412 Nm bending moment applied at the center of the shaft yielded a maximum of 0.467 mm deflection, with a maximum combined stress (bending and shear) of approximately 16.9 MPa.

27.4.2 Results of Arm Analysis

The results of the computer analysis performed on the robot arm yielded a maximum deflection of 1.31 mm, with a maximum stress of 5.2 MPa.

27.5 VERIFICATION

Verification of the computer analysis performed with I-DEAS were performed through the use of the theory of bending stress and the method of deflection by integration. These theories state that the deflection due to bending caused by an applied force can be expressed as a function of the resultant force moment, the modulus of elasticity and the moment of inertia. A complete summary of these calculations is given in Appendix M.

27.5.1 Deflection in the Shaft

The calculations performed for the analysis of the deflection in the shaft are as follows:

$$EI \frac{d^2y}{dx^2} = M(x)$$
$$\frac{d^2y}{dx^2} = \frac{M}{EI} = \text{equation of elastic curve}$$

deflection is then obtained through integration

$$NTd^2y = \int \frac{M}{EI} dx^2 = \frac{M}{EI}x + C_1 = dy$$
$$\int dy = \int \left(\frac{M}{EI} + C_1x \right) dx = \frac{M}{2EI}x^2 + C_1x + C_2 = y$$

where y is the amount of deflection measured in millimeters

Solving for C_1 and C_2 with the boundary conditions $x = 0, y = 0, x = L, y = 0$

$$\text{yields } C_2=0, C_1 = \frac{ML}{2EI}x, \text{ thus}$$

$$y = \frac{M}{2EI}x^2 + \frac{ML}{2EI}x$$

Substituting the polar moment of inertia, J for the axis moment of inertia, I , yields

$$y = \frac{M}{2EJ}x^2 + \frac{ML}{2EJ}x$$

The results of the preceding equations yielded a maximum deflection, $y = 3.55$ mm for the shaft with the following values:

$$J = \text{Polar Moment of Inertia} = 6.535(10)^7 \text{ m}^4$$

$$M = \text{Applied Bending Moment} = 412 \text{ Nm}$$

$$E = \text{Modulus of Elasticity} = 200(10)^9 \text{ N/m}^2$$

of Steel

$$L = \text{Length of Shaft} = 3.0 \text{ m}$$

$$x = \text{Distance to Applied Moment} = 1.5 \text{ m}$$

27.5.2 Stress in the Shaft

The calculations for the analysis of the stress in the shaft were performed by averaging the deflections in each cross section of the beam as follows:

$$\text{Maximum bending stress} = \sigma = \frac{Mc}{J}$$

where c is equal to the radius of the shaft
and J is equal to the polar moment of inertia of the shaft

The above equation yielded a maximum value of stress in the shaft as 16.0 MPa with the following values:

$J = \text{Polar Moment of Inertia} = 6.535(10)^7 \text{ m}^4$
 $M = \text{Applied Bending Moment} = 412 \text{ Nm}$
 $c = \text{Radius of Shaft} = 0.0254 \text{ m}$

27.5.3 Deflection in the Arm

The calculations for the analysis of the deflection in the arm were performed on each cross section of the arm over the entire length of the arm as follows:

For a fixed support cantilever beam, the maximum deflection is

$$y = -\frac{PL^3}{3EI}$$

Where I is the cross section moment of inertia calculated as follows

$$I = \frac{1}{12}(b)(h)^3 + \frac{1}{12}_b - 2t)(h - 2t)^3$$

The preceding calculation yielded a maximum deflection of $y = 1.71 \text{ mm}$ for the arm with the following values:

$b = \text{Base of Cross Section} = 162.6 \text{ mm}$
 $h = \text{Height of Cross Section} = 114.3 \text{ mm}$
 $I = \text{Moment of Inertia} = 3.656(10)^6 \text{ m}^4$
 about the x axis
 $P = \text{Applied Load} = 15 \text{ kg}$
 $L = \text{Length of Arm} = 1.83 \text{ m}$
 $E = \text{Modulus of Elasticity} = 70(10)^9 \text{ N/m}^2$
 of Aluminum

27.5.4 Stress in the Arm

The calculations for stress in the arm were performed as follows:

$$\text{maximum stress due to bending} = \sigma = \frac{Mc}{I}$$

Where I is the moment of inertia about the x axis of the cross section, c is the vertical distance from the base of the cross section to the center of the cross section, and M is the applied moment

The preceding equations yielded a maximum stress of 5.27 MPa with the following values:

$$I = \text{Moment of Inertia} = 3.656(10)^{-6} \text{ m}^4$$

$$M = \text{Applied Bending Moment} = 412 \text{ Nm}$$

$$c = \text{Vertical Distance to Centroid} = 57.5 \text{ mm}$$

27.6 OBSERVATIONS AND RECOMMENDATIONS

The type of pin connection used to model the shaft and arm arrangement does not adequately account for the fact that there might be small lateral displacements at the pin connection of the vertical shaft to the overhead rail system. It is recommended that the I_DEAS model be restricted in only the x and z directions at the top of the shaft to adequately account for the possibility of small amounts of play at the connection.

SECTION VI

TEST PLAN

PRE-TESTS

- * CENTER OF GRAVITY
- * STABILITY TEST
- * SAFETY TEST
- * CRACK TEST
- * LOAD TEST
- * PRE-FIT TEST
- * CABLE REEL SPRING TEST
- * ADHESIVE TEST
- * ACTUATOR SLIP TEST

TESTS

- * FIT TEST
- * DEFLECTION TEST
- * FIT TEST

Chapter 28.0 FACILITY LOCATIONS

- 28.1 Phase I: Engineering Building - Senior Design Laboratory
Pre-Test University of Central Florida
- 28.2 Phase II: CELSS Chamber
Model Test Kennedy Space Center

Chapter 29.0 TESTING GOALS

29.1 PRE-TESTING GOALS (U.C.F.)

- 29.1.1 Verify that all components are within design specifications.
- 29.1.2 Verify that model actuation is smooth and free of binding.
- 29.1.3 Pre-test system for fit test.
- 29.1.4 Verify that system is free of safety hazards.
- 29.1.5 Verify that system meets aesthetic requirements.

29.2 TESTING GOALS (K.S.C.)

- 29.2.1 Insure proper installation of model in CELSS chamber.
- 29.2.2 Generate data for fit and deflection testing of model at various locations in the CELSS chamber.

Chapter 30.0 PRE-TESTING OBJECTIVES AND PROCEDURES

30.1 CENTER OF GRAVITY TEST

Objective: To determine the center of mass of the model robot arm.

Procedure:

1. Use angle iron on edge of table in lab 435 to serve as a fulcrum.
2. Place model arm on top of the angle iron, ensuring that the two remain perpendicular.
3. Move arm longitudinally until it is balanced on the angle iron.

PRECEDING PAGE BLANK NOT FILMED

4. Measure the distance from the largest end of the model arm to the balance point.
5. Record the measurement as the center of gravity for the model arm.

30.2 STABILITY TEST

Objective: To determine whether the model robot arm will tip over while the arm is fully extended .

Procedure:

1. Mark the center of mass with a thin piece of tape.
2. Measure a distance of 20.3 cm from the thin tape towards the end-effector using a standard tape measure or a measuring stick.
3. Fasten a 76.2 cm section of string to the arm at the new location 20.3 cm from the center of mass position found in the previous step.
4. Tie the end of the string to a 2.3 kg weight and let the weight hang freely from the arm. The addition of the 2.3 kg weight will extend the center of mass towards the end-effector section of the arm, thus creating a larger moment and providing an adequate factor of safety for the actual test.
5. Determine whether the system is able to stand without tipping given the new center of mass.

30.3 SAFETY TEST

Objective: To ensure that the final assembly of the model arm is safe from pinch points or sharp unmarked protrusions.

Procedure:

1. All telescoping links will have pinch points at the location where the links retract into its corresponding female link. At these locations, safety tape must be applied for visual awareness of these safety hazards.
2. All sharp protrusions that are capable of cutting or causing harm can be detected by a visual inspection and by hand inspection. Any unacceptable protrusions must be filed to ensure no bodily harm can be caused under ordinary working conditions. If filing is not feasible then safety tape must be applied for visual awareness of the safety hazard.

3. Any shavings that are collected on the arm must be removed to prevent any contamination of the CELSS chamber or possible eye irritation.

30.4 CRACK TEST

Objective: To ensure that the Lexan sections contain no cracks, chips, hairline fractures, or warpage.

Procedure:

1. Inspections will occur after:
 - initial purchase.
 - cutting of each section.
 - gluing of the segments.
 - drilling holes.
 - sanding burrs and sharp edges.
2. Visual inspections will be conducted on each Lexan section. The inspections will consist of looking for hairline fractures, chips, cracks, and warpage.
3. Hand inspections will be conducted on each Lexan section. The hand inspections will consist of feeling the surfaces of the Lexan sections for non-visible hairline fractures, chips, cracks, and warpage.

30.5 NON-DESTRUCTIVE LOAD TEST

Objective: To determine the material integrity and general stability of the stand arm arrangement.

Procedure:

1. Attach arm to stand and extend to full length. Visually inspect all section of arm for chips, cracks, hairline fractures, and warpage to ensure that the model will withstand its own weight.
2. Visually inspect all adhesive locations to ensure that the adhesive has been applied along the total length of the seam.
3. Apply a series of loads to the end of the model arm. These loads should range in value from .91 - 2.3 N. Visually inspect all sections of arm for chips, cracks, hairline fractures, and warpage after each load application.

30.6 PRE-FIT TEST

Objective: Confirm model arm and model arm stand are of sufficient length to reach the necessary areas of the proposed work envelope of the NASA CELSS chamber.

Procedure:

1. Measure and mark, with chalk, a circle of 132 cm diameter to serve as the free area of the CELSS chamber floor.
2. Measure and mark, with chalk, a circle of 183 cm radius around the inner 132 cm diameter circle keeping the two circles concentric.
3. Place model base in the center of the inner circle and measure the boundary clearance between the base and the inner circle.
4. Attach arm to model stand and measure horizontal clearance between the 183 cm outer circle. Compare the measurement to the circumference of the CELSS chamber at each of the plant tray locations to ensure that they have a 2.5 cm clearance.
5. Attach model arm to stand at each of the 6 pin locations. Measure the distance from floor to arm at each pin location and compare to vertical location of each plant tray within the CELSS chamber to ensure that the arm will reach to within 1.3 cm from the bottom of the first tray to the top of the second tray.

30.7 CUT TEST

Objective: To determine the best method of cutting the Lexan sections and the cut width created by the saw blade.

Procedure:

1. Obtain Lexan and 1.3 cm plywood for backing.
2. Obtain hand circular saw with 70 tooth blade.
3. Mark a line with a pen on the Lexan's protective covering to serve as a guide for the cut test.
4. Lay the Lexan flat on the plywood backing.

5. Adjust the blade depth on the circular saw so it will cut through the Lexan and .64 cm into the plywood backing.
6. Make the cut along the line previously made varying the force applied to the saw to determine the best cutting speed. Cutting too slowly may induce melting of the Lexan.
7. Measure the width the circular saw blade created during the cut.
8. This measurement should be recorded for proper dimensioning of future cuts.

30.8 STAND ATTACHMENT TEST

Objective: To inspect stand for possible defects and also adjust for proper leveling.

Procedure:

1. Visually inspect the steel pipe for any cracks.
2. Visually inspect aluminum base plate, gussets, and sleeve for cracks.
3. Determine whether the stand is level by placing a two-directional bubble level horizontally on the base of the stand.
4. Adjust the bolts at each corner of the base plate until stand is level in both directions.
5. Ensure that there is no seizing between the steel pipe and aluminum sleeve by working the pipe into the sleeve until it is flush with the aluminum base plate.
6. Rotate pipe 360 degrees to verify smooth rotation.

30.9 SHARP-EDGE TEST

Objective: Verify no burrs and/or sharp edges are present on any components of the telescopic arm.

Procedure:

1. Carefully inspect the telescopic components visually for burrs and sharp edges.

2. Gently rub a thin cotton section along all surfaces to check for snagging, and lightly rub fingers along edges to test for sharp edges.
3. All sharp edges should be rounded and burrs removed.
4. Remove any burrs and /or sharp edges by using a smooth file on the metal parts and use 600 grit sand paper on the lexan parts. Use gentle strokes to prevent damage or deformity of the lexan.
5. Repeat procedure 1 and 2 until no burrs or sharp edges are found.
6. Remove debris from all components with alcohol.

30.10 CABLE REEL SPRING TEST

Objective: Verify cable reel spring stiffness is within acceptable range for smooth operation of the arm.

Procedure:

1. Extend cable reel to full length.
2. Form knot from cable beyond 191 cm extension point.
3. Attach tensiometer hook through cable knot.
4. Record tensiometer reading at maximum cable deployment.
5. Use force reading in drive wheel actuation test.

30.11 COLLAPSIBILITY TEST

Objective: Verify telescopic arm will extend and retract before actuator is installed.

Procedure:

1. Place mounting shaft in base.
2. Place telescopic arm on shaft and locate height with setting pins.
3. Extend the telescopic arm to its full length. Ensure smooth and proper motion.

4. Use a standard S.I. tape measure to ensure extension of arm to a minimum of 183 cm.
5. Carefully retract the telescopic arm. Ensure smooth and proper motion.
6. Use a standard S.I. tape measure to ensure collapse of arm to a maximum of 47 cm.

30.12 AESTHETICS TEST

Objective: Verify telescopic arm and all its components are presentable.

Procedure:

1. Visually inspect telescopic arm and stand to ensure components are presentable before transporting system to NASA.
2. Verify UCF, NASA, and CELSS logos are attached to the telescopic arm.
3. If any item is not presentable, consult aesthetics team for further instructions.

30.13 ROTATION TEST

Objective: Verify telescopic arm can rotate 360 degrees.

Procedure:

1. Place mounting shaft in base.
2. Place telescopic arm on shaft and locate height with setting pins.
3. Extend arm to maximum length and rotate arm in 90 degree increments.
4. At each increment, measure the height of arm from the edge of the base plate using standard S.I. tape measure.
5. Verify height at each increment is constant +/- 1 cm.

30.14 CABLE REEL ACTUATION TEST

Objective: Confirm cable reel extends and retracts cable without binding.

Procedure:

1. Extend cable from cable reel to maximum length no less than 25 times and check for binding.
2. If binding occurs, replace or adjust cable reel and repeat test until dependable cable reel actuation is achieved.

30.15 MOUNTING BRACKET TEST

Objective: Verify mounting bracket will properly secure the drive channel.

Procedure:

1. Place mounting bracket base on a known flat surface.
2. Place level on top of mounting bracket and verify the level indicator bubble is within level lines.
3. Measure ID of mounting bracket hole using micrometer.
4. If diameter is not $.56 +.0 / - .02$ cm, modify bracket or discard and fashion new bracket.
5. Place a section of the drive channel (.56 cm diameter tube) in the hole of the mounting bracket.
6. Apply polycarbonate cement to tube and Lexan interface.
7. Allow 6 days curing time.
8. Verify physically that drive channel does not slip or twist in tube.
9. If tight fit is not confirmed, repeat procedure 6 through 8 until positive lock is obtained.

30.16 ACTUATOR ARM EXTENSION AND RETRACTION TEST

Objective: Verify smooth and proper actuation of overall system before transporting to KSC.

Procedure:

1. Place mounting shaft in base.

2. Place telescopic arm on shaft and locate height with setting pins.
3. Use drive wheel mechanism to extend the arm to its maximum length.
4. Fully retract and extend arm, no less than 25 times, until convinced of reliable actuation.
5. Inspect visible internal parts for repeatability.
6. If failure occurs, retest subassemblies to correct malfunction.

30.17 ADHESIVE TEST

Objective: To establish the integrity of the adhesive bond connecting the Lexan arm links.

The adhesive test is divided into sample preparation and sample testing. Both of these two steps are in accordance with ASTM Standard Test Methods and the ASTM Handbook E8-Testing Adhesives. The test that will be used is ASTM D-1144 (determining strength developments of adhesive bonds).

Test Sample Preparation:

1. Cut six test samples from the excess Lexan. The dimensions of each test sample shall be 5.08 cm x 5.08 cm x .64 cm as determined by ASTM Handbook E8.
2. Each test specimen shall be smoothed with sandpaper to remove burrs and excess material.
3. Number each test section with permanent marker for easy reference.
4. Align two sections together along the 5.08 cm axis.
5. Apply the Polycarbonate Cement SC-325 to the edge of the Lexan sections. Allow the section to dry for 6 - 7 days as suggested by the Polycarbonate Cement SC-325 directions.
6. After allowing the test sections to dry, drill two .313 cm diameter holes in each link. Refer to Figure 30.17.1 for placement dimensions.
7. Continue steps 4, 5 and 6 for all specimens.

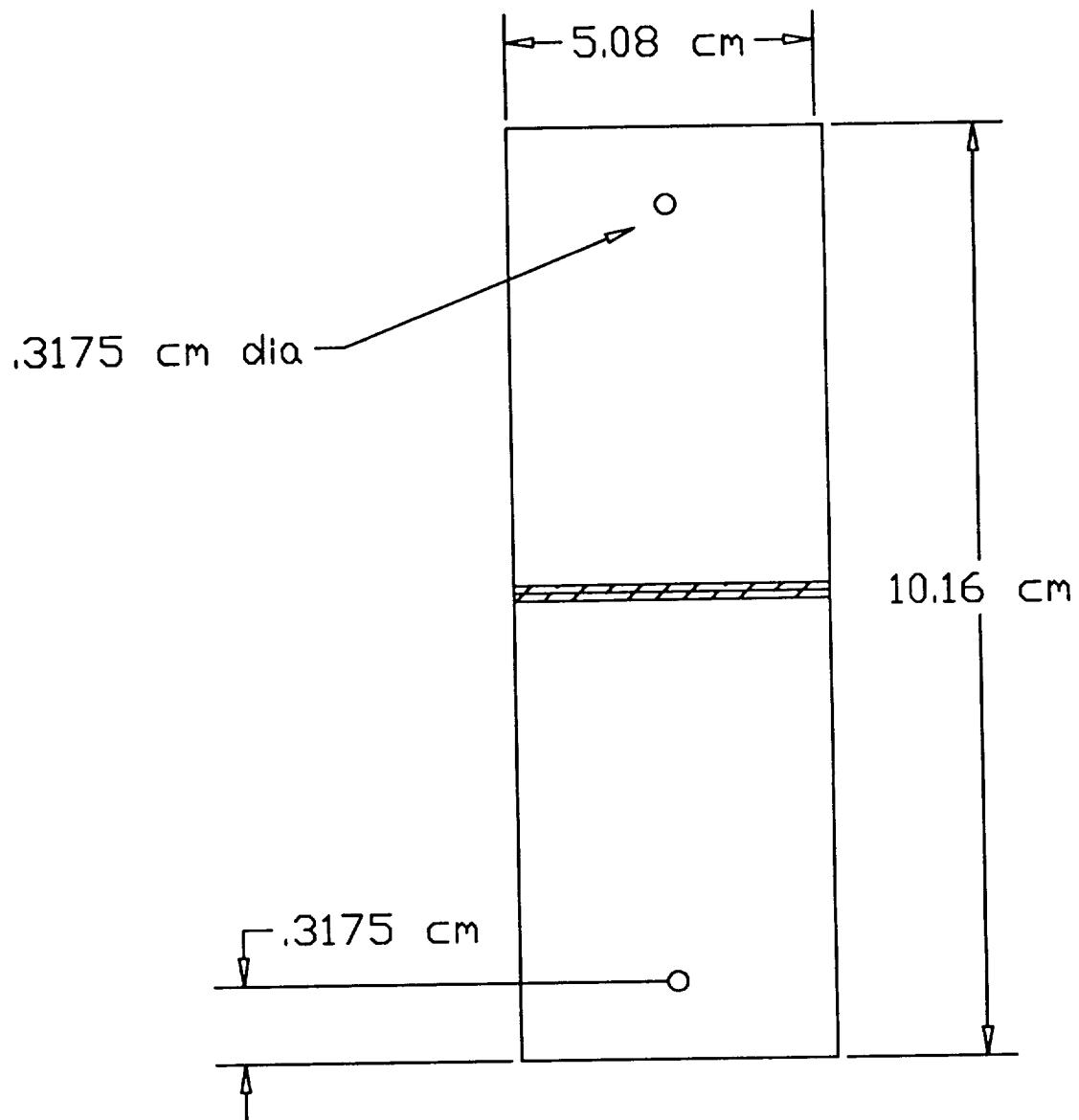

Figure 30.17.1 Specimen Drilling Location

8. There should be three specimens now ready to test.

Testing Equipment

The instrument used to test the adhesive bond strength is an Instron Uniaxial Tension Tester model 1011. This machine has twin hydraulic 45.5 kg load cells. The machine is designed to produce no moment on the sample. For this test no extensometers are necessary because only a fracture strength is needed. The machine will record, both numerically and graphically, the load versus time for the specimen during the test. The stress on the sample can then be found from the area under the curve.

The test shall be done in accordance to ASTM Standard Test Method D-1144 (determining strength development of adhesive bonds). This test is fully explained in ASTM Handbook E8 - Testing Adhesives.

Testing Procedure

1. Obtain Instron Reference Manual.
2. Refer to manual for location and setting instructions for load cells and cross heads.
3. Hold sample vertically in loosened machine grips.
4. Place main locking screw through .313 cm holes in sample. Tighten main locking screws hand tight.
5. Tighten locking plates using a .64 cm socket set until snug. DO NOT OVER TIGHTEN.
6. Find the cross head speed for sample size and material from ASTM Handbook E8.
7. Set cross head speed as instructed in reference manual.
8. Turn machine on and allow for self-calibration.
9. Make sure the data printer is on-line.
10. Put on safety eye protection.
11. Start test.

12. Continue until critical fracture has occurred.
13. Stop test.
14. Check to make sure sample broke at least 1.27 cm from the grips. This establishes that the force from the grips did not cause premature fracture.
15. Record results in notebook.
16. Label graph with time and test number.
17. Loosen grips and remove fractured Lexan sample.
18. Photograph sample for records then properly discard used sample.
19. Apply steps 3-19 for all samples.

30.18 DIMENSIONING TEST

Objective: To ensure that all of the components of the robot arm are within tolerance prior to assembly.

Procedure:

1. Measure the width 5 times along the length of the box as well as the final length to verify that each dimension is within .16 cm of the desired size.
2. Measure overall dimensions of actuator to ensure that it will fit inside completed model.
3. Measure completed model stand to ensure that it will fit inside the CELSS chamber without coming into contact with any part of the chamber.

30.19 HOLE ALIGNMENT TEST

Objective: To determine that all assemblies that are bolted or screwed together will properly fit together before final assembly.

Procedure:

Bearing Mounting Screws

1. After all holes are drilled in links one through four for the bearings, insert a 1.27 cm long alignment shaft of the same diameter as the hole.

2. Lay the bearing mount on its respected link side, sliding it over the protruding shaft aligning mounting holes with alignment shafts.
3. Check for proper fit of bearing on the link and clearances on all sides. If clearances and fit are not adequate, i.e. bearing will not slide over alignment shafts and lay flush, remove bearing.
4. Remove alignment shafts and fill hole with epoxy.
5. Redrill hole and retest.

Central Mounting Hole

1. Before assembly visually inspect hole for roundness.
2. Using a piece of the support shaft, slide the shaft through the hole.
3. Measure the gap at 30 degree increments using a feeler gage. The gap should not exceed .32 cm.
4. After assembly reinsert support shaft. Check that the angle between the support shaft and the link is between 89.5 and 90.5 degrees.

30.20 ACTUATOR SLIP TEST

Objective: To determine that there is a adequate coefficient of friction between the actuator drive wheels and the drive cable to enable the actuator to push 44.64 N.

Pre-Test Procedure:

1. Assemble the actuator and set it up on a piece of plywood in the final installed configuration.

Pull test

1. Insert manual crank into the drive wheel.
2. Attach a pull scale to the end of the actuator link and secure the other end to a fixed point.
3. Turn crank handle clockwise slowly. This will cause the actuator to retract and pull on the scale.

4. Watch the scale to determine that 4.54 N of force is reached before slipping occurs.
5. At the same time visually watch the drive wheels for slippage between the drive cable. At the point of slippage the crank handle will become suddenly easier to turn.
6. If slippage occurred before 4.54 N was achieved tighten the tension bolt on the drive wheels and repeat entire test.

Push Test

1. With the actuator in the same configuration as before remove the scale from the end of the actuator.
2. Attach the end of the scale to the base plate which serves as the rear mounting bracket for link 5.
3. Attach the other end of the scale to the adapter plate.
4. Attach the adapter plate to the front of link one.
5. Turn the handle counter-clockwise, this will cause the actuator to deploy (extend).
6. Repeat steps four through six from the pull test.

30.21 SLIDE BEARING TEST

Attachment of Slide Bearings Pre Test

Objective: Make sure that screws used to connect slide bearings to lexan sections are the proper length. Confirm that the pilot hole for the self tapping sheet metal screws are the proper dimension. Make sure that screws will hold intended load.

Procedure:

1. Using a piece of scrap lexan and a .28 cm drill bit, drill a hole in the lexan.
2. Secure slide bearing to lexan with a #6 x .95 cm sheet metal screw.
3. Look for any visible signs of cracking around pilot hole.

4. Grind off any part of screw protruding through lexan.
5. Attach a 11.4 kg (25 lb) weight to slide bearing section with a string.
6. Holding piece of lexan vertically, lift lexan piece so as to support the 11.4 kg load by the single screw to test shear strength of screw attachment.

Attachment of Slide Bearings Test

Objective: Confirm that the slide bearings are firmly attached to the lexan arm segments with no sharp protrusions prior to final assembly, (before top section of lexan is glued in place).

Procedure:

1. Visually and physically inspect all screws for proper fit and torque with a screw driver.
2. Visually and physically inspect all sections for sharp edges and protrusion of screws or glues by rubbing with a cotton ball and looking for any snagged fibers.
3. Remove any sharp edges or protruding objects using a file or sand paper to obtain a smooth finish.

30.22 REQUIRED TRAVEL ACTION OF SLIDE BEARINGS PRE TEST

Objective: Confirm that the slide bearings provide a smooth action and proper amount of travel for each section to be extended prior to final assembly, (before top section of lexan is glued in place).

Procedure:

1. Visually and physically inspect mated sections one at a time for smooth action during extension and retraction of section for 20 cycles.
2. Physically retract male section fully into female section until it hits the stop and inspect to see that the ends closest to the end effector are flush.
3. Fully extend male section until it contacts the extension stop and measure the length of the extension.
4. Make any adjustments required to achieve smooth action and required travel distance for section

5. Repeat this test procedure for each slide bearing interface in the telescopic arm.

Required Travel Action of Bearings Test

Objective: Confirm that the slide bearings provide a smooth action and proper amount of travel for each section to be extended after final assembly.

Procedure:

1. Visually and physically inspect mated sections one at a time for smooth action during extension and retraction of section.
2. Physically retract male section fully into female section until it hits the stop and inspect to see that the ends closest to the end effector are flush.
3. Fully extend male section until it contacts the extension stop and measure the length of the extension.
4. Repeat this test procedure for each slide bearing interface in the telescopic arm.

30.23 STAND LOADING TEST

Objective: Verify stand integrity and ability to withstand the required loading.

Procedure:

1. At least two persons must be present for this test.
2. Visually inspect the stand to verify it is complete and free of any obvious defects.
3. Assemble all necessary testing components including the stand, weights, and the pole attachment device.
4. Verify you are in an open area 4.72 m x 4.72 m square to ensure the safety of those involved.
5. Set the stand approximately in the center of the 4.72 x 4.72 m square.
6. Place all of the 11.4 kg weights on the stand plate. (Make sure that they are evenly distributed.)

7. Insert the direct attachment into the steel pole (Figure 30.23.1).
8. Place the 45.5 kg weight in the groove provided by the attachment.
9. Record the results.
10. Remove the 45.5 kg weight.
11. Remove the direct attachment and return to designated storage area.
12. Place the pole attachment device over the steel pole approximately 15.2 cm from the edge of the aluminum sleeve (Figure 30.23.2).
13. Slide a 6.8 kg weight onto the marks provided on the pole attachment device.
14. Record the result.
15. Remove the weight, rotate the arm approximately 90 degrees, and reattach the weight.
16. Record the result.
17. Repeat step 15 two more times; recording the results each time.

30.24 ARM WEIGHT TEST

Objective: Determine an estimated weight of the aluminum arm based on the actual weight of the Lexan test model.

Procedure:

1. Assemble telescoping arm and bearings.
2. Before incorporating actuation, weigh telescoping arm.
3. Record weight of arm.
4. Subtract weight of bearings from weight.
5. Multiply weight by ratio of density of aluminum to Lexan.
6. Record value as estimated weight of aluminum telescoping arm.

SIDE VIEW

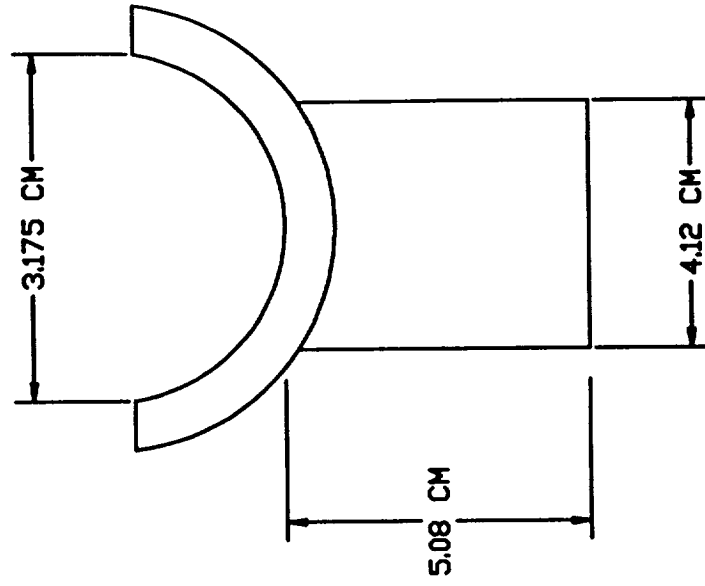

FRONT VIEW

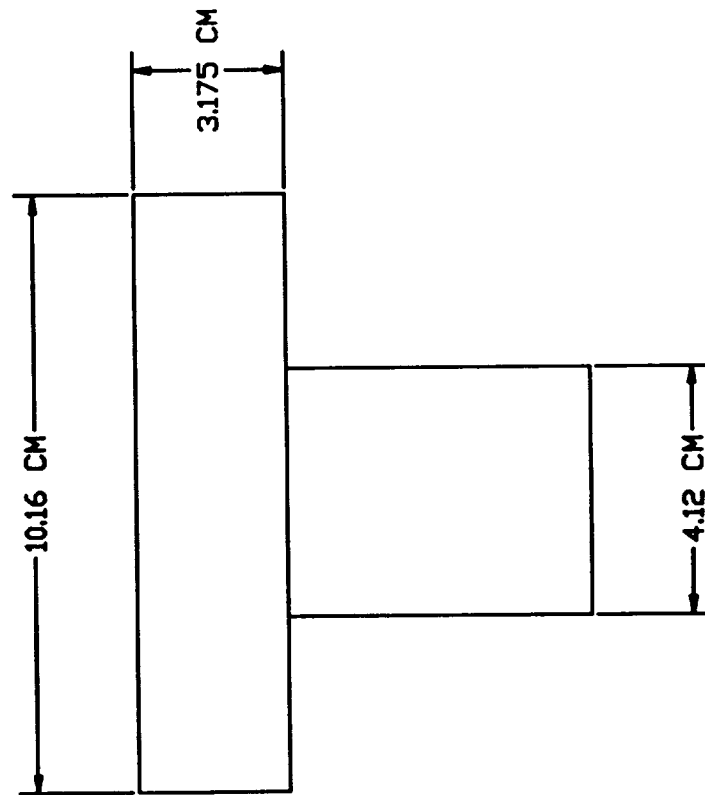

Figure 30.23.1 Direct Attachment Device

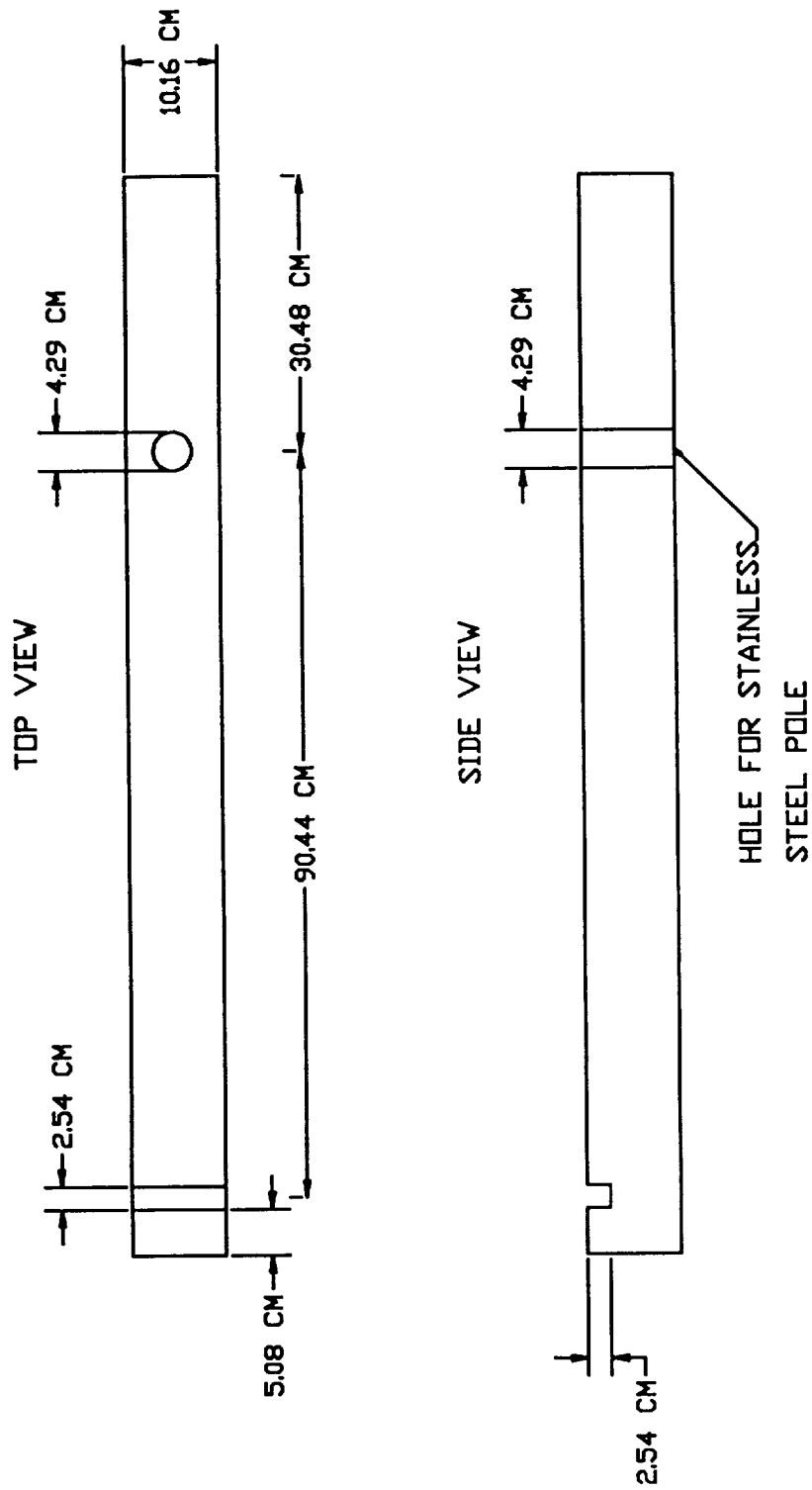

Figure 30.23.2 Pole Attachment Device

Chapter 31.0 TESTING PROCEDURES AND OBJECTIVES

31.1 KENNEDY LEVEL TEST

Objective: Ensure telescopic arm test stand is level once installed into the CELSS chamber located at KSC.

Procedure:

1. Two people, lifting with handles on opposite sides of base, will position base in chamber with support close to center of chamber.
2. Use SI tape measure to measure distance from support to wall of chamber at no less than 4 positions around chamber.
3. Modify position of base until measured distances are equal within 2 cm.
4. Place level indicator on stand in a horizontal fashion.
5. Verify level indicator bubble is within level lines.
6. If indicator is outside of level lines, adjust stand supports until level indicator is within level lines.
7. Move level indicator to a point 90 degrees from first position.
8. Verify level indicator is within level lines.
9. If indicator is outside of level lines, adjust stand supports until level indicator is within level lines.
10. Repeat procedure 2 through 7 until stand is level.

31.2 DEFLECTION TEST

Objective: To determine whether the robot arm will deflect more than 7.7 cm while in the fully extended position.

Procedure:

1. Measure half the distance of the vertical height of link 4 and link 1 with a standard tape measure or ruler and mark the point with a piece of tape or pencil mark.

2. Hold one end of a 2.15 m piece of string at the center of link 4 measured in step 2.
3. Have a second person pull the string taut along the length of the fully extended arm while a third person standing near the center of the arm with a bubble level directs him to adjust the string up or down until the string is perfectly horizontal.
4. The person holding the end-effector end of the string will measure the vertical distance between the horizontal string and the center of link 1, marked in step 2.
5. Determine whether the vertical distance is less than the 7.7 cm deflection mentioned in the objective.

31.3 FIT TEST

Objective: To ensure that the completed robot arm is capable of reaching the entire working envelope of the CELSS chamber.

Procedure:

1. Place model arm inside CELSS chamber.
2. Measure from center of the model shaft to at least ten (10) places on the chamber outer wall to ensure the model is centered in the chamber.
3. Raise arm to height just above plant tops in first row of plant trays and pin in this position.
4. Position arm so that the right edge of the arm is lined up with the right side of the plant trays that are on the right side of the door to the chamber.
5. Fully extend arm and measure distance from end of arm to the chamber wall.
6. Rotate the arm thirty degrees counterclockwise and measure the distance of the end of the arm from the chamber wall.
7. Repeat step 6 ten (10) times.
8. Fully collapse arm.

9. Raise arm vertically so that the end of the arm is level with the conduit that is attached to plant shelves.
10. Position arm so that the right edge of the arm is lined up with the right side of the plant trays that are on the right side of the door to the chamber.
11. Rotate the arm thirty degrees counterclockwise and measure the distance of the end of the arm to the conduit.
12. In the process of rotating the arm, ensure that no part of the arm comes into contact with the conduit that is attached to the plant shelves.
13. Repeat step 11 ten (10) times.

SECTION VII

TEST RESULTS

PRE-TESTS

- * CENTER OF GRAVITY
- * STABILITY TEST
- * SAFETY TEST
- * CRACK TEST
- * LOAD TEST
- * PRE-FIT TEST
- * CABLE REEL SPRING TEST
- * ADHESIVE TEST
- * ACTUATOR SLIP TEST

TESTS

- * FIT TEST
- * DEFLECTION TEST
- * FIT TEST

Chapter 32.0 PRE-TESTING OBJECTIVES AND RESULTS

32.1 CENTER OF GRAVITY

Objective: To determine the center of mass for the model robot arm.

Results: The center of mass for the model arm was determined to be 91.44 cm from the large end of the arm at full extension.

32.2 STABILITY TEST

Objective: To determine whether the model robot arm will tip over when it is fully extended.

Procedure:

1. Place the robot arm on the stand and extend it fully.
2. Apply a steady force perpendicular to the top of the central mounting shaft in the direction of the extended robot arm.
3. Apply an increasing amount of force until it begins to tip.
4. Return the robot to the original position.
5. Determine whether the robot arm system is stable enough without having to add any additional counter-balance weight to the model base.

Results: The robot arm and stand assembly withstood a 50 Newton force without tipping when the arm was at full extension. As long as the robot arm is not pushed or any external force is applied to the central mounting shaft, the system will remain stable.

32.3 SAFETY TEST

Objective: To ensure that the final assembly of the model arm is safe from pinch points, sharp edges, protrusions and shavings.

Procedure:

1. Visually inspect the final assembly to find all sharp protrusions.
2. Visually inspect the robot arm for residual shavings and dirt on the arm which may contaminate the CELSS chamber.

PRECEDING PAGE BLANK NOT FILMED

Results: All sharp edges and protrusions were filed and sanded until smooth, rounded surfaces were formed. All surfaces of each arm section were wiped clean using rubbing alcohol.

32.4 CRACK TEST

Objective: To ensure that the Lexan sections contain no cracks, chips, hairline, fractures, or warpage.

Procedure:

1. Inspect the Lexan after initial purchase, cutting of each section, gluing of the segments, drilling holes, and sanding burrs and sharp edges.
2. Visual inspection will be conducted by holding the Lexan pieces up to a light source to locate cracks in the Lexan. If any imperfections are present, they will be visible through the protective covering.
3. The Lexan sections are set of a flat surface and are visually inspected at eye level along the entire length to locate any warpage.

Results: None of the sections had any hairline fractures, chips, cracks, or therefore, all Lexan sheets passed the crack test.

32.5 PRE-FIT TEST

Objective: Confirm model arm and model arm stand are of sufficient length to reach the necessary areas of the proposed work envelope of the NASA CELSS chamber.

Procedure:

1. Measure and record the length of the arm in the fully extended position.
2. Measure and record the length of the arm in the fully retracted position.

Results: The retracted length of the model arm was determined to be 81.6 cm. The extended length was measured to be 2.14 m. These results are within tolerance.

32.6 CUT TEST

Objective: To determine the best method of cutting the Lexan sections and the cut width created by the saw blade.

Results: The optimum cutting speed for the Lexan is 6 inches per second. The cut width created by the blade was determined to be 1/8" +/- 1/32".

32.7 STAND ATTACHMENT TEST

Objective: To inspect stand for possible defects and adjust for proper leveling.

Procedure:

1. Visually inspect the steel pipe, aluminum base plate, gussets, and sleeve for cracks.
2. Determine whether the stand is level by placing a two-directional bubble level on the vertical shaft.
3. Adjust bolts at each corner of base plate until stand is level in the vertical direction.
4. Ensure that there is no seizing between the steel pipe and the aluminum sleeve by working the pipe into the sleeve until it is flush with the aluminum base plate.
5. Rotate pipe manually 360 degrees to verify smooth rotation.

Results: Upon visual inspection of the steel pipe, aluminum base plate, gussets, and the aluminum sleeve, it was determined that no visible cracks were present.

When the base plate was welded to the sleeve along with the gussets, warpage occurred. Steel angles were bolted onto the bottom of the aluminum plate along all four edges to straighten the base plate. This straightened the base plate considerably and the four corner bolts were adjusted until the robot arm was horizontal.

There was no seizing or sticking between the steel pipe and aluminum sleeve.

32.8 SHARP EDGE TEST

Objective: Verify no burrs and/or sharp edges are present on any components of the telescopic arm.

Results: All components of the telescopic arm were inspected prior to assembly. All edges were rounded using sand paper for Lexan and a smooth file for

metal. Burrs were detected using a cotton swab, and removed using sand paper for Lexan and a smooth file for metal.

32.9 CABLE REEL SPRING TEST

Objective: Verify cable reel spring stiffness is within acceptable range for smooth and proper operation of arm.

Procedure:

1. Attach the cable reel and drive wheel mechanism to the final mounting location on the telescopic arm.
2. Feed the cable into the drive wheel mechanism.
3. Actuate the drive wheel mechanism until the cable has extended to the maximum length.
4. Verify no slippage of the cable occurs on the drive wheel mechanism.
5. If slippage occur, inspect sand paper on drive wheel mechanism for surface roughness and replace if necessary.
6. If slippage continues, remove and replace cable reel spring with a spring having a lower spring constant.

Results: At maximum extension, cable exhibited no slippage.

32.10 COLLAPSIBILITY TEST

Objective: Verify telescopic arm will extend and retract before actuator is installed.

Results: The telescopic arm extended and retracted in a smooth and proper manner. At maximum extension the arm measured 183 cm. At minimum extension, the arm measured 50 cm.

32.11 AESTHETICS TEST

Objective: Verify the telescopic arm and all its components are presentable.

Results: The aluminum base was polished using aluminum polish. The Lexan was cleaned of contaminants using alcohol. The NASA, CELSS, and UCF logos were applied to both sides of the arm.

32.12 ROTATION TEST

Objective: Verify telescopic arm can rotate 360 degrees in a level fashion.

Results: The arm was rotated at 30 degree increments. Due to warpage of the base, measurements were made from the arm tip to the floor. All measurements were consistent within +/- 1 cm.

32.13 CABLE REEL ACTUATION TEST

Objective: Confirm cable reel extends and retracts without binding.

Results: The cable reel was actuated to its maximum length and completely retracted 25 times. No binding occurred.

32.14 MOUNTING BRACKET TEST

Objective: Verify mounting bracket will properly secure the drive channel.

Results: Mounting brackets were level when placed on a flat surface. The holes were drilled smaller than the tubing. The tubing was press fit into the holes and cemented in place. The bracket functioned adequately after curing for 2 days.

32.15 ACTUATOR ARM EXTENSION AND RETRACTION TEST

Objective: Verify smooth and proper actuation of overall system before transporting to KSC.

Results: The arm was extended to its maximum length and completely retracted 5 times. The arm moved in a smooth and proper manner. More testing of the arm would have been completed but, the drive wheel sand paper useful life was shorter than expected. Frequent replacement of the sand paper was necessary.

32.16 ADHESIVE TEST

Objective: To establish the integrity of the adhesive bond connecting the Lexan arm links.

The test is in accordance with ASTM Standard Test Methods and ASTM Handbook E8 - Testing Adhesives. The test used is ASTM D-1144 (determining strength development of adhesive bonds).

The instruments used is an Instron Uniaxial Tension tester model 1011. This machine is designed to test axial load strength. No moment was applied to the sample.

Results: Three samples were tested after the adhesive cured for 7 days. The results were 560, 580, and 605 psi. Two samples broke at the adhesive bond, while one sample broke at the attachment holes to the machine. The values found provide a large factor of safety against failure for the adhesive bonds.

32.17 DIMENSIONING TEST

Objective: To ensure that all of the components of the robot arm are within tolerance prior to assembly.

Procedure:

1. Measure the width of each piece of lexan five times along the length, and the overall length to ensure that each dimension is within 0.16 cm of the desired length.
2. Measure completed model stand to ensure that it will fit inside the CELSS chamber without coming into contact with any part of the chamber.

Results: All four components of each link were measured at intervals along the length and the overall length. The right side of link #4 was found to be too wide and was re-cut. The following are the final measurements recorded during this test, if there are two values given for a measurement then they are the high and low end of the measurement variations:

Link/Side	Actual (L X W) (cm)	Desired (L X W) (cm)
1/Top	44.37 X 5.12	44.45 X 5.08
1/Bottom	44.45 X 5.08	44.45 X 5.08
1/Right	44.37 X 6.51	44.45 X 6.35
1/Left	44.37 X 6.51	44.45 X 6.35
2/Top	44.45 X 8.89, 8.97	44.45 X 8.89
2/Bottom	44.61 X 8.89, 8.97	44.45 X 8.89
2/Right	44.45 X 8.89, 8.97	44.45 X 8.89
2/Left	44.45 X 9.05, 8.97	44.45 X 8.89
3/Top	81.28 X 12.86	81.28 X 12.7
3/Bottom	81.28 X 12.86	81.28 X 12.7
3/Right	81.28 X 11.75, 11.59	81.28 X 11.43

3/Left	81.28 X 11.59, 11.43	81.28 X 11.43
4/Top	81.28 X 15.24	81.28 X 15.24
4/Bottom	81.28 X 15.4	81.28 X 15.24
4/Right	81.28 X 14.29	81.28 X 13.97
4/Left	81.28 X 14.13, 13.97	81.28 X 13.97

The measurements for 3/Right and 4/Right were out of tolerance by 0.16 cm. It was determined that this discrepancy would not pose a problem, because these are side pieces and they will not interfere with the operation of the bearings.

The stand base measured 76.2 X 76.2 cm which will fit inside the chamber without contacting any part of the chamber.

32.18 ACTUATOR SLIP TEST

Objective: To determine there is an adequate coefficient of friction between the actuator drive wheels and the drive cable to enable the actuator to fully extend and retract the arm.

Procedure:

1. Assemble the actuator and install it into the arm.
2. Attach the electric screw driver to the drive shaft.
3. Use the electric screw driver to turn crank handle clockwise for the extension of arm and counterclockwise for the retraction of the arm.
4. During the extension process visually watch for pausing or stoppage of the arm.
5. At the same time watch for slippage between the drive pulley and the drive cable. If slippage occurs the force required to hold the screw driver in place will suddenly lessen.
6. Should any slipping occur during the extension process, tighten the compression bolt to increase the friction and retest.

Results: The preliminary tests revealed that the coefficient of friction between the drive wheel and the drive cable was not high enough to prevent slipping. Sandpaper was glued to the drive wheel, thus increasing the friction factor. The test was then redone and adequate friction was achieved to prevent slipping. However, repeated testing showed that the life of sandpaper on

the drive wheel is extremely short. The design was changed to allow for easy replacement of the drive wheel.

32.19 ATTACHMENT OF SLIDE BEARING PRE-TEST

Objective: Make sure that screws used to connect slide bearings to lexan sections are the proper length. Confirm that the pilot hole for the self tapping sheet metal screws are the proper dimension. Make sure that screws will hold intended load.

Procedure:

1. Using a piece of scrap lexan, drill a 7/64 inch hole in the lexan.
2. Secure slide bearing to lexan with a #6 by 3/8 inch sheet metal screw.
3. Look for any visible signs of cracking around pilot hole.
4. Grind off any part of screw protruding through lexan.
5. Attach an 11.4 kg (25 lb.) weight to slide bearing section with a metal strap using an 8-32 screw and nut.
6. Holding a piece of lexan vertically, lift lexan piece to support the 11.4 kg. load by the single screw to test shear strength of screw attachment.

Results: When the hole was drilled in the lexan, the drill bit tended to bind and care needed to be taken not to break the bit in the hole. Otherwise, the holes were drilled with no other complications.

When the bearings were firmly attached to the lexan the screw holes showed no signs of cracking but, unfortunately the screws protruded out of the lexan. To overcome this, the screws were first screwed into a scrap piece of lexan without the bearings and ground flat to the surface of the lexan.

For the static loading test, the weights were attached to the bearing as described above. The screws showed no signs of straining and have supported more weight.

32.20 ATTACHMENT OF SLIDER BEARING TEST

Objective: Confirm that the slide bearings are firmly attached to the lexan arm segments with no sharp protrusions prior to final assembly, (before top section of lexan is glued in place).

Procedure:

1. Visually and physically inspect all screws for proper fit and torque with a screw driver.
2. Visually and physically inspect all sections for sharp edges and protrusion of screws or glues by rubbing with a cotton ball and looking for any snagged fibers.
3. Remove any sharp edges or protruding objects using a file or sand paper to obtain a smooth finish.

Results: All the screws were checked for a uniform torque. Some of the screws required a final adjustment. A cotton ball was rubbed across all screw holes and some careful trimming and filing was required to get a smooth finish.

32.22 REQUIRED TRAVEL ACTION OF SLIDE BEARING PRE-TEST

Objective: Confirm that the slide bearings provide a smooth action and proper amount of travel for each section to be extended prior to final assembly, (before top section of lexan is glued in place).

Procedure:

1. Visually and physically inspect mated sections one at a time for smooth action during extension and retraction of section for 20 cycles.
2. Physically retract male section fully into female section until it hits the stop and inspect to see that the ends closest to the end effector are flush.
3. Fully extend male section until it contacts the extension stop and measure the length of the extension.
4. Make any adjustments required to achieve smooth action and required travel distance for section

5. Repeat this test procedure for each slide bearing interface in the telescopic arm.

Results: For the interface between the first section, the end effector section, the slide bearings fit properly and worked as expected. They were cycled 25 times and exhibited no signs of binding. The travel distance for this slide bearing action measured 33 cm as required for this section.

When the slide bearings were mounted for the interface between the second section and the third, some binding occurred. The clearance between the second and third section was at the minimum allowable and the frames of the wheel tracks were making contact during the last ten centimeters of collapse. A dremmel tool with a grinding wheel was used to grind down the frames of the slide bearings to get the required clearance and smooth action. The metal frames were then sanded to remove any sharp edges. The travel distance for this slide bearing action measured 33 cm as required for this section. The slide was cycled 25 times successfully.

The interface between the third section and the fourth would require that two sets of slides be cut and fitted together to get the required travel of 66 cm. When the bearings were cut and fitted to the sections they worked smoothly except at the joint of one of the male slides. Due to slight differences of bearing pairs from manufacturing or mounting, the wheel tracks did not align perfectly. It was required that one of the tracks be shimmed to provide smooth transition at the bearing joint. This was done by placing thin layers of plastic under one of the bearings to make it level with the other. The proper extension length of 66 cm was achieved with a smooth action for 25 cycles.

32.22 REQUIRED TRAVEL ACTION OF BEARING TEST

Objective: Confirm that the slide bearings provide a smooth action and proper amount of travel for each section to be extended after final assembly.

Procedure:

1. Visually and physically inspect mated sections one at a time for smooth action during extension and retraction of section.
2. Physically retract male section fully into female section until it hits the stop and inspect to see that the ends closest to the end effector are flush.

3. Fully extend male section until it contacts the extension stop and measure the length of the extension.
4. Repeat this test procedure for each slide bearing interface in the telescopic arm.

Results: After final assembly the arm and stand were taken to the CELSS chamber and tested for smooth action and reachability. The arm sections worked smoothly but the arm possessed too much reach due to the oversight of a grating installed on the inside of the chamber walls. Other than this oversight in measurements of the CELSS chamber the arm met all the test requirements of the slide bearings.

32.23 STAND LOADING TEST

Objective: Verify stand integrity and ability to withstand the required loading.

Results: The direct attachment device test was not performed. It was determined that if the stand could handle the load applied by the pole attachment device, then a vertical load would not cause any problems. The pole attachment device was fitted to the steel pole. There was a noticeable amount of deflection, however, since the deflection had no bearing on the test, it was ignored. A 63.5 kg weight was placed at the end of the pole attachment device (point of placement was at 85.44 cm from the center line of the through holes). The stand and pole were capable of holding the weight, however, it required an additional loading on the stand plate to keep it from tipping over.

Chapter 33.0 TESTING PROCEDURES AND OBJECTIVES

33.1 KENNEDY LEVEL TEST

Objective: Verify telescopic arm test stand is level when installed into the CELSS chamber at KSC.

Results: The shaft was centered using a tape measure to within +/- 1 cm of the center. These measurements were taken in relation to the perimeter metal sheeting lining the back of the shelves. The shaft was level within the limits of the bubble level indicator and was rechecked with a plumb bob.

33.2 DEFLECTION TEST

Objective: To determine whether the robot arm will deflect more than 7.7 cm while in the fully extended position.

Procedure:

1. Measure half the distance of the vertical height of link 4 and link 1 with a standard tape measure or ruler and mark the point with a piece of tape or pencil mark.
2. Hold one end of a 2.15 m piece of string at the center of link 4 measured in step 1.
3. Have a second person pull the string taut along the length of the fully extended arm while a third person standing near the center of the arm with a bubble level directs him to adjust the string up or down until the string is perfectly horizontal.
4. The person holding the end of the string measures the vertical distance between the horizontal string and the center of link 1 marked in step 1.
5. Record the distance measured in step 4 for the test results.

Results: When the robot was set in a horizontal position, it appeared to have a slight deflection at the small end of the arm. It was determined that the deflection was 5.4 cm. This is within the maximum tolerance of 7.7 cm.

33.3 FIT TEST

Objective: To ensure that the completed robot arm is capable of reaching the entire working envelope of the CELSS chamber.

Procedure:

1. Place model arm inside CELSS chamber.
2. Measure from center of model shaft to at least ten (10) places on chamber outer wall to ensure model is centered in chamber.
3. Raise arm to height just above plant tops in first row of plant trays and pin in this position.
4. Position arm so that the right edge of the arm is lined up with the right side of the plant trays that are on the right side of the door to the chamber.
5. Fully extend arm and measure distance from end of arm to the back of plant trays.

6. Rotate the arm thirty degrees counterclockwise and measure the distance from the end of the arm to the back of the plant trays.
7. Repeat step 6 ten (10) times.
8. Fully collapse arm.
9. Raise arm vertically so that the end of the arm is level with the drain pipes that are attached to the top row of plant trays.
10. Position arm so that the center of the arm is lined up with the drain pipe at the far right.
11. Measure the distance from the end of the arm to the drain pipe.
12. Rotate the arm counterclockwise so that the center of the arm is lined up with the next drain pipe.
13. In the process of rotating the arm ensure that no part of the arm comes into contact with the conduit that is attached to the plant shelves.
14. Repeat steps 11 and 12 fifteen (15) times.

Results: The robot was centered in the chamber. The arm was capable of reaching the back of all plant trays and was 15.24 cm longer than necessary. The end of the robot was a minimum of 7.94 cm and a maximum of 14.92 cm from the drain pipes.

SECTION VIII

SUMMARY

SUMMARY

The 1993-1994 senior Aerospace Engineering Design class designed and tested a CELSS robot for use in the Controlled Ecological Life Support System chamber. The design class was divided into three teams during the first semester to distribute the work load. The first team designed an overhead rail system that positioned the robot in the center of the CELSS chamber. The second group designed the vertical shaft. The vertical shaft provided a means of moving a telescopic arm vertically and radially. The final team designed a telescopic arm that was capable of reach all the area within the work envelope.

The Overhead Rail Team designed the track system and the base assembly. The center point of the ceiling was determined the most effective operating position of the base. For greatest stowability the robot must stow along the wall of the chamber. The track allows the movement of the base assembly between the ceiling center point and the wall. This movement requires two people. The base assembly moves the robot smoothly along the track, and fixes the robot in place when stowed and deployed.

The vertical Shaft Teams design incorporates the use of a combination ball screw / ball spline actuator to control the vertical motion of the CELSS chamber robot arm. A central mounting structure is mounted to the ball nut and the ball spline race. A dual "V" guide is used as an interface between the mounting structure and the ball screw nut. This central mounting structure contains a system of motors and pulleys which are used as control systems. One motor is used to rotate the ball nut, while the second motor is used to control the dual "V" guide used for rotation of the robot arm. The rotation of the ball nut provides the necessary vertical motion to position the mounting structure along the shaft. The ball spline race adds to the stability of the system and is used to prevent angular rotation of the mounting structure while still allowing for vertical motion. Rotational motion of the robot is achieved through the use of the dual "V" guide which is actuated by the second motor located in the central mounting structure. The robot arm is bolted to the dual "V" guide. The upper end of the ball screw / ball spline shaft is attached to a plate which is attached to the overhead rail mounting of the CELSS chamber.

The Telescopic Arm Team designed the telescopic arm sub-system. Slider bearings facilitate the movement of each link of the telescopic arm. The actuator system is small enough to fit into the fourth link as well as powerful enough to extend and retract the telescopic arm. The team also designed a method of sequencing the arm links so the smallest links extend and retract before the larger links. This allows the moments to act on the larger links instead of the smaller links.

During the second semester, three teams were combined into one group. The class designed a model of the CELSS chamber robot that could be built by the students. They investigated materials, availability, and strength in their design. The arm links were built out of Lexan. The class used slider bearings to ease the sliding of the links. The model stand was built out of an aluminum base with a steel shaft positioned vertically.

~~PRECEDING PAGE BLANK NOT FILMED~~

After the model arm and stand were built, the class performed pre-tests on the entire system. A stability pre-test was used to determine whether the model robot arm would tip over on the stand when it was fully extended. The results are that the stand tipped when 50 Newtons were applied to the top of the stand while the arm was fully extended. This proved that the stand was stable. Another pre-test was the actuator slip test. This was to determine if there is an adequate coefficient of friction between the actuator drive wheels and the drive cable to enable the actuator to fully extend and retract the arm. This pre-test revealed that the coefficient of friction between the drive wheel and the drive cable was not large enough to prevent slippage. Sandpaper was glued to the drive wheel and this eliminated the slippage problem.

The class performed a fit test in the CELSS chamber. This test was to ensure that the completed robot arm is capable of reaching the entire working envelope of the CELSS chamber. The robot was centered in the chamber. The arm was able to fully extend to the sides of the CELSS chamber. The arm was also able to retract to clear the drain pipes that separated the upper and lower plant trays.

Future work on the CELSS chamber robot is envisioned to include building a prototype of the robot. This aluminum prototype will contain a control system to move the telescopic arm vertically and radially. To provide needed skills the Senior Aerospace Design class will include Electrical and Computer Engineering students thus creating a truly interdisciplinary Engineering Design class.

REFERENCES

1. Baker, Nathan, Description of CELSS Project, National Aeronautics and Space Administration, 1993.
2. Baker, Nathan, CELSS Project Requirements, National Aeronautics and Space Administration, 1993.
3. Van De Vegte, John, Feedback Control Systems, Prentice-Hall, 1990
4. Doughty, S., Mechanics of Machines, McGraw-Hill, NY, 1990
5. Safety Checklist, National Aeronautics and Space Administration, 1993.
6. James, M.L., Smith, G.M., Wolford, J.C., Waley, P.W., Vibrations of Mechanical and Structural Systems, Harper and Row, NY, 1989.
7. Product Catalog, LinTech Corporation, 1983.
8. Product Catalog, Simplicity Bearing Corporation, 1990.
9. Smith, W., Structure and Properties of Engineering Alloys, McGraw-Hill, NY, 1993.
10. Papov, Egor, Engineering Mechanics of Solids, Prentice-Hall, NJ, 1990
11. Parmley, Robert O., Standard Handbook of Fastening and Joining, 2nd Ed., McGraw-Hall, NY, 1989.
12. Beer & Johnson, Mechanics of Materials, McGraw-Hill, NY, 1992.
13. Shigley, Joseph, Mechanical Engineering Design, McGraw-Hill, NY, 1989.
14. Harris & Crede, Shock and Vibration Handbook, McGraw-Hill, NY, 1976.
15. Rehg, James. Introduction to Robotics, Prentice Hall Inc. Engle Wood Cliffs, New Jersey, 1985, pp. 5-29.
16. Andeen, Gerry B. (ED.), Robot Design Handbook, 1st ed., McGraw-Hill, New York, 1988, pp. 32-47.
17. Koren, Yoram. Robotics for Engineers, New York: McGraw-Hill Book Company, 1985, pp. 17, 35-48.

18. Avallone, E.A., Baumeister, T., Marks' Standard Handbook for Mechanical Engineers, Ninth Edition, McGraw-Hill Book Company, New York, 1987.
[a] Page 3.26, Table 3.2.1
[b] Page 3.28
[c] Page 8.133, Figure 8.5.18, Table 8.5.2
[d] Page 13.46
19. Bassin, M.G., Brodsky, S.M., Wolkoff, H., Statics and Strengths of Materials, Third Edition, McGraw-Hill Book Company, New York, 1979.
20. Palmgren, Arvid, Dr. Engr., Ball and Roller Bearing Engineering, third Edition, Copyright, SKF Industries, Inc., Philadelphia, Pa., Printed, S.H. Burbank and Company, Inc., Philadelphia, Pa.
[a] Page 80, Table 3.2, Page 82, Equation 31.07, Page 83, Figure 3.03
[b] Page 39, Page 122, Table 5.1, Page 123, Table 5.2

APPENDICES

APPENDIX A
SPECIFICATION
UCF-SPEC-293

PREVIOUS PAGE BLANK NOT FILMED

1.0 SCOPE

1.1 Scope

1.2 Purpose

1.3 Definition

2.0 APPLICABLE DOCUMENTS

2.1 Specifications

2.1.1 Federal None

2.1.2 Military None

2.1.3 NASA

KSC-SPEC-G-0002 Compiling construction cost estimates, specifications for.

2.1.4 Other None

2.2 Standards

2.2.1 Federal None

2.2.2 Military

MIL-STD-700 Plastics.

MIL-STD-454 Standard general requirements for electronic equipment.

MIL-STD-889B Dissimilar metals.

MIL-STD-1472D Human engineering design criteria for military systems, equipment and facilities.

2.2.3 NASA

KSC-STD-C-0001 Protective coating of carbon steel, stainless steel and aluminum on launch structures and ground support equipment.

KSC-STD-Z-0004 Structural steel buildings and other structures, the design of, standard for.

KSC-STD-118 Failure Mode and Effect Analysis and single failure points analyses, standard for preparation of.

- 2.2.4 Other None
- 2.3 Drawings None
- 2.4 Bulletins None
- 2.5 Other Documents

- 2.5.1 Directorates

- KSC-DE-512-SM Facility, system, and equipment. General design requirements.

- 2.5.2 Handbooks

- MIL-HDBK-5 Metallic materials and elements for aerospace vehicle structures.

- MIL-HDBK-149 Rubber.

3.0 REQUIREMENTS

3.1 Definition The following are requirements for a robot that shall be incorporated into the existing Controlled Ecological Life Support System (CELSS) project at Kennedy Space Center.

3.2 Performance Requirements

3.2.1 General Performance Requirements

3.2.1.1 Materials

3.2.1.1.1 Material properties shall be defined.

3.2.1.1.2 Materials shall not alter the chamber environment.

3.2.1.1.3 Materials shall resist corrosion.

3.2.1.1.4 Materials shall resist fungus growth.

3.2.1.1.5 Dissimilar metals shall not be used in direct contact with each other.

3.2.1.1.6 Materials shall resist stress corrosion cracking (SCC).

3.2.1.2 Kinematics

3.2.1.2.1 Robot shall have adequate flexibility.

3.2.1.2.2 Robot shall be of minimum kinematic complexity.

3.2.1.2.3 Robot shall be stowable.

3.2.1.2.4 Velocity shall be adequate.

3.2.1.2.5 Acceleration shall be adequate.

3.2.1.3 Critical Parts

3.2.1.3.1 Design shall minimize the number of critical parts.

3.2.1.3.2 Parts shall be designed to handle necessary force.

3.2.1.4 Actuators

3.2.1.4.1 Actuators shall not alter the chamber environment.

3.2.1.4.2 Standardized parts shall be used whenever possible.

3.2.1.5 Fasteners

3.2.1.5.1 Standardized parts shall be used whenever possible.

3.2.1.5.2 The number of fasteners shall be minimized.

3.2.1.5.3 The number of fasteners requiring torque application is minimized.

3.2.1.5.4 Bolt and screw length shall not be excessive.

3.2.1.6 Cost

3.2.1.6.1 Cost shall be minimized.

3.2.1.6.2 A cost estimate shall be established.

3.2.1.6.3 Overall cost shall be limited.

3.2.1.7 Life

3.2.1.7.1 Use of items with limited life shall be avoided whenever possible.

3.2.1.7.2 Life expectancy of items shall be adequate.

3.2.2 Specific Performance Requirements

3.2.2.1 Materials

3.2.2.1.1 Material properties shall be defined in accordance with MIL-HDBK-5 for metals, MIL-HDBK-149 for rubber, MIL-HDBK-700 for plastics.

3.2.2.1.2 Materials shall not out-gas or contain fluids or lubricants which may alter the chamber environment.

3.2.2.1.3 Materials shall resist corrosion or be coated in accordance with KSC-STD-C-0001.

3.2.2.1.4 Materials susceptible to the growth of fungus shall be avoided in accordance with MIL-STD-454.

3.2.2.1.5 Separation by use of barrier tapes, protective coatings, and other methods of isolation shall be used in accordance with MIL-STD-889.

3.2.2.1.6 Materials shall be selected that are highly resistant to stress corrosion cracking in accordance with KSC-STD-Z-0004.

3.2.2.2 Kinematics

3.2.2.2.1 Kinematic flexibility shall allow access to any point in the chamber.

3.2.2.2.2 Design shall incorporate the minimum necessary number of degrees of freedom.

3.2.2.2.3 Configuration shall not inhibit stowability.

3.2.2.2.4 Velocity shall not exceed 15.5 cm/sec.

3.2.2.2.5 Acceleration shall not exceed TBD cm/sec².

3.2.2.3 Critical Parts

3.2.2.3.1 Design shall minimize critical parts to avoid failure of entire system in accordance with KSC-STD-118.

3.2.2.3.2 Design shall incorporate a minimum safety factor of 2 over yield in accordance with KSC-DE-512-SM.

3.2.2.4 Actuators

3.2.2.4.1 Actuators shall not contain fluids or lubricants that may alter the chamber environment.

3.2.2.4.2 Existing vendor parts shall be used whenever possible.

3.2.2.5 Fasteners

3.2.2.5.1 Similar fasteners shall be used whenever possible in accordance with MIL-HDBK-5F.

3.2.2.5.2 Large fasteners shall be used in lieu of many small fasteners.

3.2.2.5.3 Fasteners requiring torque application above TBD shall be avoided.

3.2.2.5.4 Bolt and screw length is not excessive to the application in accordance with MIL-STD-1472D.

3.2.2.6 Cost

3.2.2.6.1 Life-cycle costs shall be minimized by use of existing vendor parts.

3.2.2.6.2 Cost estimate shall be in accordance with KSC-SPEC-G-0002.

3.2.2.6.3 Overall cost shall not exceed TBD.

3.2.2.7 Life

3.2.2.7.1 Items with limited life shall be identified and their use shall be controlled in accordance with KSC-DE-512-SM.

3.2.2.7.2 Design shall incorporate a useful life minimum of 20 years in accordance with KSC-DE-512-SM.

3.3 Operational Requirements

3.3.1 General Operational Requirements

3.3.1.1 Critical Parts

3.3.1.1.1 All critical parts shall be identified.

3.3.1.1.2 Redundancies shall be used to support critical parts.

3.3.1.2 Fasteners

3.3.1.2.1 Fasteners shall be easily installed and removed.

3.3.1.2.2 Fasteners shall be accessible.

3.3.1.3 Transportability

3.3.1.3.1 Robot shall be of a suitable size for transportation.

3.3.1.3.2 Robot shall have suitable handholds for transportation.

3.3.1.3.3 Robot shall fit in a vehicle for transportation.

3.3.1.3.4 Robot shall be of a suitable weight for transportation.

3.3.1.3.5 Robot handling requirements shall be specified.

3.3.2 Specific Operational Requirements

3.3.2.1 Critical Parts

3.3.2.1.1 Parts exhibiting TBD characteristics shall be considered critical parts.

3.3.2.1.2 Redundancies shall support critical parts in accordance with KSC-STD-118.

3.3.2.2 Fasteners

3.3.2.2.1 Fasteners shall be installed and removed by hand or with standard tools.

3.3.2.2.2 Fasteners shall be placed in locations easily accessible by standard tools in accordance with MIL-STD-1472D.

3.3.2.3 Transportability

3.3.2.3.1 Robot shall be modular in design so as to be broken down into manageable sections for transportation.

3.3.2.3.2 Particular areas of each modular section must be specifically designated as handholds and must be resistant to breaking under normal handling conditions.

3.3.2.3.3 Each modular section must be a size which is transportable in a standard light truck.

3.3.2.3.4 Each modular section must be transportable by one person with a hand cart.

3.3.2.3.5 The safe orientation of each modular section during shipping and any necessary padding or special handling requirements shall be specified.

4.0 VERIFICATIONS

4.1 Definition The following tests are intended to verify that the requirements of the CELSS robot apparatus have been satisfied.

4.2 Performance Verifications

4.2.1 General Performance Verification

4.2.1.1 Materials

4.2.1.1.1 Review manufacturing documentation to confirm that defined properties are satisfied.

4.2.1.1.2 Review manufacturer documentation and, if necessary, perform closed environment tests on all material.

4.2.1.1.3 Use materials specifications to confirm corrosion resistance.

4.2.1.1.4 Use material specifications to confirm resistance to fungus growth.

4.2.1.1.5 Visually verify that no dissimilar metals are in contact.

4.2.1.1.6 Use material specifications to confirm resistance to stress corrosion cracking.

4.2.1.2 Kinematics

4.2.1.2.1 A kinematic modeling technique, shall confirm that the limits of motion of the arm match the dimensions of the chamber.

4.2.1.2.2 Use kinematic modeling to confirm that the minimum number of degrees of freedom have been established.

4.2.1.2.3 Use kinematic modeling to shall verify stowability.

4.2.1.2.4 Verify velocity characteristics through kinematic analysis.

4.2.1.2.5 Verify acceleration characteristics through kinematic analysis.

4.2.1.3 Critical Parts

4.2.1.3.1 Use Failure Mode and Effect Analysis (FMEA) to determine the effect of critical part failure.

4.2.1.3.2 Use FMEA to verify that the specified factor of safety is employed on all components.

4.2.1.4 Actuators

4.2.1.4.1 Review manufacturing data to confirm TBD requirements properties of the actuators are satisfied.

4.2.1.4.2 Use market research to be conducted to determine availability of existing vendor parts.

4.2.1.5 Fasteners

4.2.1.5.1 Review inventory parts list to verify similar parts are used.

4.2.1.5.2 Review inventory parts list to verify similar parts are used.

4.2.1.5.3 Use design review to verify that torque application is not necessary.

4.2.1.5.4 Use design review to verify that bolt length is not excessive.

4.2.1.6 Cost

4.2.1.6.1 Use market research to confirm that existing vendor parts are used whenever possible.

4.2.1.6.2 Verify format of estimate through comparison with specification..

4.2.1.6.3 Verify using economic cost analysis.

4.2.1.7 Life

4.2.1.7.1 Verify using material analysis and manufacturer specifications.

4.2.1.7.2 Verify using material analysis and manufacturer specifications.

4.3 Operational Verifications

4.3.1 General Operational Verifications

4.3.1.1 Critical Parts

4.3.1.1.1 Use Failure Mode and Effect Analysis (FMEA) to determine critical parts.

4.3.1.1.2 FMEA shall be used to determine effect of redundancies.

4.3.1.2 Fasteners

4.3.1.2.1 Verify using vendor catalogs or test installation and removal of fasteners..

4.3.1.2.2 Review Design to confirm accessibility.

4.3.1.3 Transportability

4.3.1.3.1 Review design to confirm modularity.

4.3.1.3.2 Perform FMEA on all designated handholds.

4.3.1.3.3 Verify using dimensional analysis of design.

4.3.1.3.4 Perform weight estimation.

4.3.1.3.5 Review design to confirm correct procedures.

5.0 PACKAGING

6.0 NOTES

6.1 Acronyms

FMEA	Failure Model and Effect Analysis
CELSS	Controlled Ecological Life Support System
TBD	To Be Determined

APPENDIX B
SPECIFICATION
UCF-SPEC-193

1.0 SCOPE

1.1 Scope N/A

1.2 Purpose N/A

1.3 Definition N/A

2.0 APPLICABLE DOCUMENTS

2.1 Specifications

2.1.1 Federal none

2.1.2 Military

2.1.2.1 MIL-C-5015 Connectors, Electrical, Circular Threaded, AN Type, General Specification for

2.1.2.2 MIL-C-22992 Connectors, Plugs and Receptacles, Electrical, Waterproof, Quick Disconnect, Heavy Duty Type, General Specification for

2.1.2.3 MIL-C-26482 Connectors, Electrical (Circular, Miniature, Quick Disconnect, Environment Resisting), Receptacles and Plugs, General Specification for

2.1.2.4 MIL-C-38999 Connector, Electrical, Circular, Miniature, High Density, Quick Disconnect, (Bayonet, Threaded and Breech Coupling), Environment Resistant, Removable Crimp and Hermetic Solder Contacts, General Specification for

2.1.3 NASA

2.1.3.1 KSC-SPEC-E-0031 Cables, Electrical, General Specification For

2.1.3.3 KSC-SPEC-E-0017 Electrical Power Cables, Installation of, Specification for

2.2 Standards

2.2.1 Federal none

2.2.2 Military

2.2.2.1 MIL-STD-975 NASA Standard Electrical, Electronic and Electromechanical (EEE) Parts List

2.2.3 NASA

2.2.3.1 DE-PD 8830.2E Operations and Maintenance Documentation

2.2.3.2 KSC-STD-Z-0004D The Design of Structural Steel Buildings and Other Structures, Standard for

2.2.3.3 MSFC-STD-486A Standard Threaded Fasteners, Torque Limits for

2.2.3.4 KSC-STD-141A Load Test Identification and Data Marking standard for

2.2.3.5 KSC-STD-E-0014 Standard for Wire and Cable applications, 60 Hz AC Power

2.2.4 Other

2.2.4.1 ASTM E380 Use of the International System of Units (SI) (the Modernized Metric System), Standard Practice for.

2.2.4.2 ANSI Y14.5-82 Dimensioning and Tolerancing

2.3 Technical Manuals and Reports

2.5.3.1 GP-435 Engineering Standards

2.4 Management Instruction

2.5.1.1 KMI 5350.1 KSC Maintainability Program

2.5.1.2 KMI 5320.4 NASA Standard Parts Program

2.5 Drawings none

2.6 Bulletins none

2.7 Other Documents

2.7.1 Textbooks

- 2.7.1.1 Smith, W.F., Principles of Material Science and Engineering, 2nd ed., McGraw-Hill, 1990
- 2.7.1.2 Morgan, C., Robots: planning and Implementation, 1st ed., IFS Publications, New York, 1984
- 2.7.1.3 Leatham-Jones, B., Elements of Industrial Robotics, 1st ed., Pitman Publishing, London, 1987
- 2.7.1.4 Ardayfio, D.D., Fundamental of Robotics, 1st ed., Marcel Dekker, Inc., New York, 1987
- 2.7.1.5 Rivin, E.E., Mechanical Design of Robots, 1st ed., McGraw-Hill, Inc., New York, 1988

3.0 REQUIREMENTS

3.1 Definition The following are requirements and constraints for the design of a robot which shall be incorporated into the Controlled Ecological Life Support System (CELSS) chamber at Kennedy Space Center.

3.2 Performance Requirements

3.2.1 General Performance Requirements

3.2.1.1 Robot Characteristics

- 3.2.1.1.1 Robot shall have the required degrees of freedom necessary to perform all tasks.
- 3.2.1.1.2 The robots weight shall not exert excess stress on the structure of the CELSS chamber.
- 3.2.1.1.3 The robot shall function at speeds necessary to productively complete required tasks.
- 3.2.1.1.4 The robot shall manipulate the end effector at necessary levels of accuracy.
- 3.2.1.1.5 The performance and reliability of the robot shall not be affected by the atmospheric extremes of the CELSS chamber.

- 3.2.1.1.6 The robot shall be stowable.
- 3.2.1.1.7 The robot shall be capable of reaching all areas within the working envelope of the CELSS chamber.
- 3.2.1.1.8 Robot shall be sufficiently stable to perform required tasks.
- 3.2.1.1.9 Robot shall remain stable while holding tools and or sensors in stationary positions.
- 3.2.1.1.10 Robot shall not be electrically or electro-mechanically hazardous to the operating systems of the CELSS chamber.
- 3.2.1.1.11 Electrical, electronic and electromechanical (EEE) parts shall be selected commensurate with the criticality of the application and the life cycle of the hardware to be used.

3.2.1.2 Strength Requirements

- 3.2.1.2.1 The robot shall support the required maximum load at the end effector.
- 3.2.1.2.2 Under maximum loading the robot shall meet or exceed the required structural safety factor.
- 3.2.1.2.3 Structural analysis shall be supplied for all critical elements of the robot.

3.2.1.3 Impact To Environment

- 3.2.1.3.1 While in the stowed position the robot shall not interfere with the normal operations of the CELSS chamber.
- 3.2.1.3.2 Robot material shall not produce any harmful substances or otherwise contaminate the CELSS chamber environment.
- 3.2.1.3.3 Installation of robot system shall require minimal CELSS chamber facility modification.
- 3.2.1.3.4 Robot bearings shall not contaminate the CELSS chamber environment.
- 3.2.1.3.5 The robot shall not affect the operating temperature of the CELSS chamber.

- 3.2.1.3.6 The robot structure shall not interfere with normal airflow in the CELSS chamber.
- 3.2.1.3.7 The robot shall not interfere with the humidity levels of the CELSS chamber.
- 3.2.1.3.8 The installation of the robot structure shall minimize any permanent effects on the CELSS environment.
- 3.2.1.3.9 The robot mechanism shall not damage the interior of the CELSS chamber or its contents.
- 3.2.1.3.10 The driving mechanism of the robot shall not contaminate the environment of the CELSS chamber.
- 3.2.1.3.11 Routine robot maintenance procedures shall not contaminate the CELSS chamber environment.
- 3.2.1.3.12 No component of the robot shall become detached causing damage to any part of the CELSS chamber environment or its contents.

3.2.1.4 Documentation

- 3.2.1.4.1 All documentation shall be supplied in a legible, reproducible and organized format.
- 3.2.1.4.2 Reports shall be provided in hard copy and/or on diskette.
 - 3.2.1.4.2.1 Drawings within reports shall be provided in hard copy.
- 3.2.1.4.3 Engineering drawings shall be provided in hard copy and on diskette
- 3.2.1.4.4 Engineering analysis shall be provided hard copy and disk

3.2.2 Specific Performance Requirements

3.2.2.1 Robot Characteristics

- 3.2.2.1.1 The TBD degrees of freedom of the robot shall enable the end effector to perform all tasks in the working envelope of the CELSS chamber.

- 3.2.2.1.2 The weight and mounting of the robot system shall not damage the structure of the CELSS chamber.
 - 3.2.2.1.3 The robot shall operate at a maximum velocity of 15.24 cm/s \pm TBD cm/s dependent upon the task to be performed.
 - 3.2.2.1.4 The robot shall be capable of manipulating the end effector within \pm 0.635 cm of accuracy.
 - 3.2.2.1.5 The robot shall remain operational at the temperature, humidity and other TBD extreme conditions of the CELSS chamber.
 - 3.2.2.1.6 The robot shall be stowable in a TBD space in the CELSS chamber.
 - 3.2.2.1.7 Robot shall be capable of motion sufficient to enable access to all TBD work areas of the CELSS chamber.
 - 3.2.2.1.8 Robot shall not vibrate and shall remain stable to within TBD hertz (Hz) during operation.
 - 3.2.2.1.9 Robot shall remain securely mounted to the CELSS chamber and shall remain stable to within \pm TBD mm when the arm is in a stationary position in the operational mode.
 - 3.2.2.1.10 Robot system design shall identify and comply with any and all hazard proofing requirements for electrical, and electromechanical systems operating in the CELSS chamber.
 - 3.2.2.1.11 Determination of the EEE grade shall be based on the specific circuit function and its associated criticality in accordance with KMI 5320.4 based on a twenty (20) year life of the robot.
- 3.2.2.2 Strength Requirements
- 3.2.2.2.1 The Robot shall support a maximum load capacity of fifteen (15) kilograms at the end effector.
 - 3.2.2.2.2 Under maximum loading the robot shall meet or exceed the required structural safety factor of two (2) over yield for the material used.

3.2.2.2.3 Structural analysis for all critical elements of the robot shall be performed using TBD methods.

3.2.2.3 Impact To Environment

3.2.2.3.1 The robot shall stow within a TBD space of the CELSS chamber allowing normal operations.

3.2.2.3.2 Materials used shall not leak, out-gas, or produce anodic corrosive products that shall contaminate the CELSS chamber environment.

3.2.2.3.3 Minimal structural and electrical modifications shall be made to the CELSS chamber.

3.2.2.3.4 Robot bearings shall not leak any lubricants or out-gas into CELSS chamber.

3.2.2.3.5 The operation of the robot shall not affect the temperature of the CELSS chamber by more than TBD degrees celsius.

3.2.2.3.6 The robot structure shall not interfere with the airflow of the CELSS chamber by more than TBD kg/s.

3.2.2.3.7 The robot shall not interfere with the humidity levels of the CELSS chamber by more than TBD percent.

3.2.2.3.8 The robot mounting hardware will be removable and will not require any permanent modifications to the CELSS chamber structure.

3.2.2.3.9 The robot mechanism shall not inadvertently drop, collide with, break or damage any part of the CELSS chamber or its contents.

3.2.2.3.10 The driving mechanisms of the robot shall not leak, or out-gas contaminates into the environment of the CELSS chamber.

3.2.2.3.11 During scheduled routine robot maintenance, no lubricants, solvents, or any other harmful substance shall be administered into the CELSS chamber environment.

3.2.2.3.12 No cable, bolt, joint or component of the robot shall become inadvertently detached causing damage to any part of the CELSS chamber or its contents.

3.2.2.4 Documentation

3.2.2.4.1 All documentation shall be type written or generated on a computer and presented in a format specified by NASA.

3.2.2.4.2 Reports shall be submitted with one (1) 3½ inch computer disk using Word Perfect 5.1 and on one (1) hard copy using 8½ X 11 inch white paper.

3.2.2.4.2.1 Drawings within a report, per GP 435; dimensioning and tolerancing per ANSI Y14.5-82 to be supplied as one (1) legible and reproducible hard copy.

3.2.2.4.3 Engineering Drawings, per GP 435 Level 1 (conceptual); dimensioning and tolerancing per ANSI Y14.5-82 to be supplied as one (1) legible and reproducible hard copy and on (1) one 3½ inch disk

3.2.2.4.4 Engineering analysis shall be submitted using the same format outlined in the above two (2) sections. The type of analysis software used is optional. All pertinent data shall be supplied on hard copy and on 3.5 inch disk.

3.3 Operational Requirements

3.3.1 General Operational Requirements

3.3.1.1 Maintainability

3.3.1.1.1 Maintainability shall be considered when selecting materials and components to insure efficient maintenance.

3.3.1.1.2 Maintenance requiring removal of other components shall be minimized.

3.3.1.1.3 Use of special tools and test equipment shall be minimized.

3.3.1.1.4 The number of different types of components shall be minimized.

- 3.3.1.1.5 Whenever possible the robot system components shall be chosen so replacements shall be readily available from vendors.
- 3.3.1.1.6 Preventative maintenance requirements and frequencies shall be minimal.
- 3.3.1.1.7 Required maintenance personnel and skill level shall be minimal.
- 3.3.1.1.8 Useful life of system components shall be specified.
- 3.3.1.1.9 System operation and maintenance shall be facilitated with a clearly visible labeling system
- 3.3.1.1.10 Labeling on cables, wiring, tubing and piping shall be located at sequenced intervals to minimize identification search time.
- 3.3.1.1.11 Labeling of all replaceable parts shall be clearly visible and well organized.

3.3.1.2 Accessibility

- 3.3.1.2.1 Openings for physical access shall be as unrestrictive as possible.
- 3.3.1.2.2 Access openings shall be sufficiently large to provide effective maintenance.
- 3.3.1.2.3 Access covers shall be readily opened or removed to perform maintenance functions.
- 3.3.1.2.4 Complexity of case/cover fasteners shall be minimized.
- 3.3.1.2.5 Replaceable system components shall be physically accessible.

3.3.1.3 Dimensions

- 3.3.1.3.1 All dimensions shall be given in standard SI units.

3.3.1.4 Stowability

- 3.3.1.4.1 The robot shall stow in the CELSS chamber in a position so as not to interfere with normal chamber operations.
- 3.3.1.4.2 The robot shall stow in a fully assembled configuration.

3.3.1.5 Cables, Connectors and Wiring

- 3.3.1.5.1 The system cable and wiring shall be readily secured and removed.
- 3.3.1.5.2 Cable and wiring installations shall not be hazardous to other system components or maintenance.
- 3.3.1.5.3 Cables and wiring shall not contain deformations due to strain.
- 3.3.1.5.4 Cable and wiring installations are routed to prevent damage from outside factors.
- 3.3.1.5.5 Cable and wiring installations shall be routed to reduce their risk to human mobility within the CELSS chamber work envelope.
- 3.3.1.5.6 Cable and wiring installations shall not interfere with normal operation of system or CELSS chamber.
- 3.3.1.5.7 Connectors shall be used so the cables and wiring installation harnesses shall be removable.
- 3.3.1.5.8 Cables and wires shall be efficiently removable and replaceable.
- 3.3.1.5.9 Improper connection of cables during installation or maintenance shall be prevented.
- 3.3.1.5.10 Connectors used shall not permit corrosion or cable deterioration.
- 3.3.1.5.11 Adequate stocks of replacement connectors shall be available.
- 3.3.1.5.12 Connectors shall be easily removed and readily accessible.

- 3.3.1.5.13 Critical connectors shall be resistant to inadvertent disconnect or intermittent conditions.
- 3.3.1.5.14 Cables and wiring are designed to avoid contact with liquids and to prevent fluid contact with connections/terminations.
- 3.3.1.5.15 Installation of electrical power cables shall be in accordance with appropriate specifications.
- 3.3.1.5.16 Electrical power cables shall be made of the appropriate material.
- 3.3.1.5.17 Electrical power cables shall be used to provide power to the robot.
- 3.3.1.5.18 Selection of electrical connectors shall be in accordance with appropriate specifications.

3.3.2 Specific Operational Requirements

3.3.2.1 Maintainability

- 3.3.2.1.1 Maintenance requirements shall be minimized through the use of sealed bearings and other components that require little or no maintenance.
- 3.3.2.1.2 Disassembly of primary structure is prohibited, and execution of maintenance routines shall require minimal removal of components.
- 3.3.2.1.3 Design shall consist of standardized parts and module/component mounting fasteners shall be interchangeable.
- 3.3.2.1.4 Components with identical electrical and or mechanical functions shall be interchangeable.
- 3.3.2.1.5 Off the shelf components shall be used, whenever possible, to insure availability of replacements.

- 3.3.2.1.6 Low maintenance, long life system components and lubricants will be used to minimize preventative maintenance frequency requirements.
- 3.3.2.1.7 The number and skill levels of technicians needed to perform maintenance procedures is TBD.
- 3.3.2.1.8 Equipment retirement and shelf life shall be specified and provided with documentation.
- 3.3.2.1.9 Identifying labels shall be provided for the following:
 - 1) Racks and consoles
 - 2) Panel controls and meters
 - 3) Attach points for tiedowns
 - 4) Access openings, servicing and lubrication areas
 - 5) Cables, connectors, wiring, tubing, piping and lift points.
- 3.3.2.1.10 Labeling on cables, wiring, tubing and piping is repeated at no more than five (5) foot intervals and at each end to minimize searching for identification.
- 3.3.2.1.11 All replaceable parts shall be labeled in plain view with the following permanently readable information:
 - 1) Part Number
 - 2) Revision
 - 3) Manufacturer (CAGE)
 - 4) Serial Number
 - 5) Description
 - 6) Model Number.

3.3.2.2 Accessibility

- 3.3.2.2.1 The following order of preference is used for physical access openings; no cover unless safety or performance is degraded, sliding or hinged doors, or covers with a minimum number of standard captive fasteners.
- 3.3.2.2.2 Access openings for maintenance shall permit full or partial body access, and include space for tool and component passage.
- 3.3.2.2.3 Access covers shall be equipped with grasp areas or handles to assist in opening and closing.

3.3.2.2.4 Case/cover fasteners shall be of the quick disconnect type and non-removable covers shall be self supporting in the open position.

3.3.2.2.5 Sufficient space shall be provided for physical and visual accessibility and disconnect of replacement units.

3.3.2.3 Dimensions

3.3.2.3.1 All dimensions shall be given in standard SI units as referenced in std ASTM E380 REV*A 91.

3.3.2.4 Stowability

3.3.2.4.1 The robot shall stow in a TBD location in the CELSS chamber so that it shall not interfere with normal chamber operations.

3.3.2.4.2 Disassembly of the robot system shall not be necessary to stow within the TBD area of the CELSS chamber.

3.3.2.5 Cables, Connectors, and Wiring

3.3.2.5.1 Cables and wiring routed through holes, etc, shall be easily removable and adequately protected with grommets, etc.

3.3.2.5.2 Cable and wiring installations shall be clear of sharp edges and moving parts.

3.3.2.5.3 Cables and wiring shall be routed for strain relief, and to avoid sharp bends, either in-place or when connected or disconnected.

3.3.2.5.4 Cables and wiring shall be routed to avoid pinching by doors, racks, consoles, drawers, panels, clamps, etc.

3.3.2.5.5 Cables and wiring shall be routed so they cannot be walked on or used as hand holds.

3.3.2.5.6 Cables and wiring shall be routed to avoid interference or connection with the existing operational equipment within the CELSS chamber.

- 3.3.2.5.7 Cable and wiring harnesses shall be designed for fabrication in removable sections.
- 3.3.2.5.8 The connectors selected shall be of standard quick-disconnect or plug-in type and sufficient stocks of slack loops shall be available to allow for maintenance procedures.
- 3.3.2.5.9 The connectors and receptacles shall be clearly identified and coded to prevent insertion into the wrong receptacle. Connectors with alignment keys and slide guides shall be used to prevent improper connection.
- 3.3.2.5.10 Connectors used shall be moisture proof.
- 3.3.2.5.11 TBD quantities of replacement connectors shall be available.
- 3.3.2.5.12 Connectors are removable by hand, and are far enough from obstructions to permit grasping firmly.
- 3.3.2.5.13 Lock wiring is used on critical connectors to prevent inadvertent disconnect or intermittent conditions.
- 3.3.2.5.14 Cables and wiring are located to avoid contact with liquids or liquid carrying lines, and drip loops are designed into all cable and wiring installations to prevent fluids from flowing down to connectors/terminations.
- 3.3.2.5.15 Installation of electrical power cables shall be in accordance with KSC-SPEC-E-0017.
- 3.3.2.5.16 Electrical power cables shall be flexible multiconductor neoprene-jacketed cables in accordance with KSC-SPEC-E-0031.
- 3.3.2.5.17 Sixty (60) hertz alternating current power cable shall be used in accordance with KSC-STD-E-0014.
- 3.3.2.5.18 Electrical connectors shall be selected from the following basic families of connectors: MIL-C-5015, MIL-C-22992, MIL-C-26482, MIL-C-38999.

4.0 VERIFICATIONS

4.1 Definition The following tests and procedures shall be used to verify the requirements and specifications of the CELSS chamber robot as set forth in this document.

4.2 Performance Requirements

4.2.1 General Performance Verification

4.2.1.1 Robot Characteristics

- 4.2.1.1.1 Visually verify the degrees of freedom are sufficient to perform all tasks in the CELSS chamber.
- 4.2.1.1.2 Perform an engineering stress analysis shall be performed on the CELSS chamber structure at the TBD area of installation. Visually inspect system mounting to insure the absence of cracks and/or deformations.
- 4.2.1.1.3 Track cycle times for tasks performed by robot to ensure the maximum speed (15.24 cm/s \pm TBD cm/s) is attainable while productively completing required tasks.
- 4.2.1.1.4 Conduct performance tests of specific tasks by physically measuring levels of accuracy of each task performed in mm.
- 4.2.1.1.5 Perform testing under maximum environmental stress conditions to verify operational reliability of robot.
- 4.2.1.1.6 Compare physical dimensions of robot in stowed configuration with the actual physical measurement of the CELSS chamber storage space prior to installation.
- 4.2.1.1.7 Perform kinematic analysis of robot system prior to installation to insure that all necessary areas of the CELSS chamber working envelope can be reached.
- 4.2.1.1.8 Conduct performance tests with physical distance and strain gage analysis to inspect stability of robot while performing required tasks.

- 4.2.1.1.9 Conduct performance tests with physical distance and strain gage analysis to inspect stability of robot arm under loaded conditions in stationary positions.
- 4.2.1.1.10 Verify through review of system documentation the robot complies with all hazard proofing requirements for electrical and electromechanical system components.
- 4.2.1.1.11 Visually inspect all EEE parts to insure selection was commensurate with the application of the life cycle of the hardware to be used.

4.2.1.2 Strength Requirements

- 4.2.1.2.1 Apply loads equivalent to 125% of required operational loads; visually verify the robot structure withstands these loads without the propagation of cracks or permanent deformations before installation.
- 4.2.1.2.2 Perform non-destructive load testing to verify capacity of the robot arm and compare results to required structural safety factor.
- 4.2.1.2.3 Verify validity of structural analysis of all critical elements of the robot through TBD methods.

4.2.1.3 Impact to Environment

- 4.2.1.3.1 Perform standard comparison evaluation of operations before and after installation to ensure robot compatibility with CELSS chamber operations requirements.
- 4.2.1.3.2 Perform quantitative comparison evaluation of atmospheric conditions before installation with conditions after installation.
- 4.2.1.3.3 Verify with client no unnecessary modifications have been made to the CELSS chamber facility during installation of robot system.
- 4.2.1.3.4 Verify through product research, standard documentation and materials literature referenced system bearings do not leak, outgas, or corrode.

- 4.2.1.3.5 Verify robot operations do not affect the chambers mean operational temperature by performing temperature evaluation before and after installation.
 - 4.2.1.3.6 Verify robot does not affect airflow by performing airflow comparison analysis before and after installations of robot.
 - 4.2.1.3.7 Verify robot does not affect humidity by performing humidity comparison analysis before and after installation of robot.
 - 4.2.1.3.8 Perform quantitative comparison analysis of CELSS chamber environment before and after installation of robot system. Verify with client that CELSS chamber facility has not been unnecessarily modified.
 - 4.2.1.3.9 Verify through TBD analytic methods structural integrity of CELSS chamber before and after installation of robot. Refer to performance tests conducted in sections 4.2.1.1 and 4.2.1.2 to verify stability and control of robot system.
 - 4.2.1.3.10 Verify through product research, product specifications, and materials literature driving mechanism of robot does not leak, out-gas, or is corrosive. Perform quantitative analysis of driving mechanism operation before installation of robot.
 - 4.2.1.3.11 Visually and quantitatively verify the robot routine maintenance procedures do not administer harmful substances into the CELSS chamber environment.
 - 4.2.1.3.12 Verify through product research, part specifications and materials literature the structural integrity of robot system. Conduct non-destructive performance evaluation tests of fully assembled system at maximum velocity and maximum load capacity to insure system integrity.
- 4.2.1.4 Documentation
- 4.2.1.4.1 Review documentation to insure it is legible, reproducible and in an organized format.
 - 4.2.1.4.2 Visually verify the format of reports.

4.2.1.4.2.1 Visually verify the format of drawings within reports.

4.2.1.4.3 Visually verify the format of engineering drawings.

4.2.1.4.4 Visually verify the format of engineering analysis.

4.3 Operational Requirements

4.3.1 General Operational Verifications

4.3.1.1 Maintainability

4.3.1.1.1 Perform analysis of maintenance time in man-hours and evaluate the results. Verify efficiency with client.

4.3.1.1.2 Verify routine maintenance can be performed without excessive removal of robot components.

4.3.1.1.3 Verify testing and maintenance requires minimal use of specialized tools and or equipment.

4.3.1.1.4 Verify through inventory that the number of different types of components is minimal.

4.3.1.1.5 Verify through parts list inventory that the number of off the shelf components used was maximized.

4.3.1.1.6 Verify preventative maintenance requirements and frequencies are minimal through a review of maintenance procedure documentation.

4.3.1.1.7 Verify number and level of training of maintenance personnel to be sufficient through review of maintenance documentation. Verify replaceability of components by client technicians.

4.3.1.1.8 Verify through review of system component parts list and documentation that useful life of each component is specified.

4.3.1.1.9 Visually verify visibility of labeling system on component parts inventory.

4.3.1.1.10 Visually verify labeling sequence on cables, wiring, tubing and piping inventory.

4.3.1.1.11 Visually verify labeling of replacement parts inventory.

4.3.1.2 Accessibility

4.3.1.2.1 Perform physical test on all access openings to verify non-restrictive movement.

4.3.1.2.2 Perform a simulated maintenance procedure involving all physical access openings to insure sufficient space is allowed for tool and component passage.

4.3.1.2.3 Perform physical test on all access covers to insure opening and removeability.

4.3.1.2.4 Verify simplicity of case/cover fasteners through review of fastener documentation.

4.3.1.2.5 Verify physical accessibility of replaceable system components by performing a simulated replacement of one or more components.

4.3.1.3 Dimensions

4.3.1.3.1 Verify all dimensions comply with ASTM E380 REV*A 91 standards by reviewing all required documentation.

4.3.1.4 Stowability

4.3.1.4.1 Perform standard comparison evaluation of operations before and after installation of robot to insure robot compatibility with CELSS chamber operations requirements.

4.3.1.4.2 Visually verify no disassembly is required to deploy and operate the robot from the stowed position.

4.3.1.5 Cables, Connectors and Wires

4.3.1.5.1 Physically verify system cable and wiring can be readily secured and removed.

- 4.3.1.5.2 Visually inspect all cable and wiring installations to insure no sharp edges or twists are present.
- 4.3.1.5.3 Visually verify all cable connections are free of deformation.
- 4.3.1.5.4 Visually inspect cable routing to insure damage from external factors does not occur.
- 4.3.1.5.5 Visually inspect cable routing to insure that they do not interfere with human mobility within the CELSS chamber.
- 4.3.1.5.6 Visually inspect cable routing to prevent interference with normal operations of the system or the CELSS chamber.
- 4.3.1.5.7 Physically inspect cable and wiring harnesses to insure they are removable.
- 4.3.1.5.8 Verify with client efficiency of cable installation and replacement.
- 4.3.1.5.9 Visually inspect cable connectors to insure proper labeling, slide guides or keys exist.
- 4.3.1.5.10 Perform routine visual inspection of cables and connectors for the absence of corrosion.
- 4.3.1.5.11 Verify adequate inventories of replacement connectors.
- 4.3.1.5.12 Verify physically connectors are accessible and removable.
- 4.3.1.5.13 Analyze performance of all critical connectors during normal operations to insure they are resistant to inadvertent disconnect or intermittent conditions.
- 4.3.1.5.14 Visually inspect all cables and wiring to insure they avoid contact with liquids and prevent fluid contact with connections/terminations.
- 4.3.1.5.15 Visually verify power cables have been installed.
- 4.3.1.5.16 Verify type of electrical power cables installed through visual inspection and review of robot system parts specifications.

4.3.1.5.17 Visually inspect electric power cables to insure appropriate types are used.

4.3.1.5.18 Verify use of proper connectors by cross referencing with specifications called for in 3.3.2.5.18

5.0 PACKAGING N/A

6.0 NOTES

6.1 Acronyms

6.1.1	ANSI	American National Standards Institute
6.1.2	CELSS	Controlled Ecological Life Support System
6.1.3	EEE	Electrical, Electronic and Electromechanical
6.1.4	KMI	Kennedy Management Instruction
6.1.5	KSC	Kennedy Space Center
6.1.6	NASA	National Aeronautics and Space Administration
6.1.7	SI	Systems International
6.1.8	SPEC	Specification
6.1.9	STD	Standard
6.1.10	TBD	To Be Determined

APPENDIX C

TORQUE, SPEED AND ACCELERATION DETERMINATION

Torque, Speed and Acceleration Determination

NOMENCLATURE

J	Polar Moment of Inertia.
r	Radius.
ω	Angular Velocity.
α	Angular Acceleration.
N	Number of teeth.
T	Torque.
g	Gravity.
V	Velocity.

The following section provides a detailed account of the torque, speed, and acceleration calculations performed on the vertical and rotational shaft actuator subsystem of the CELSS chamber robot.

ROTATIONAL CALCULATIONS

- 1.) Calculation of polar moment of inertia for robot arm.

$$\begin{aligned} J_{\text{ARM}} &= Wr^2/3g \\ &= 16.8 \text{ kg m s}_2 \end{aligned}$$

where W is the weight and r is the radius of motion of the arm.

- 2.) Calculation of polar moment of inertia for anticipated load.

$$\begin{aligned} J_{\text{LOAD}} &= Wr^2/g \\ &= 45.4 \text{ kg m s}^2 \end{aligned}$$

where W is the weight, and r is the radius of motion of the arm.

3.) Calculation of total polar moment of inertia.

$$\begin{aligned} J_{TOT} &= J_{ARM} + J_{LOAD} \\ &= 62.2 \text{ kg m s}^2 \end{aligned}$$

* NOTE: The polar moment of inertia for the gear is negligible in the above calculation.*

4.) Calculation of polar moment of inertia for pinion.

$$\begin{aligned} J_{PINION} &= J_{TOT}(N_p/N_G)^2 \\ &= 0.74 \text{ kg m s}^2 \end{aligned}$$

Where N_p , and N_G are the number of teeth of the pinion and gear respectively, and $N_G/N_p = 9.2$.

5.) Calculation of angular velocity.

$$\begin{aligned} \omega &= V/r \\ &= 0.53 \text{ rad/s} \end{aligned}$$

Where V , the maximum velocity at the end effector is 15 cm/s.

6.) Calculation of the angular acceleration of the gear.

$$\begin{aligned} \alpha_G &= \Delta\omega/\Delta t \\ &= 0.265 \text{ rad/s}^2 \end{aligned}$$

Where $\Delta t = 2 \text{ sec}$, and $\Delta\omega = 0.53 \text{ rad/sec}$.

7.) Calculation of the angular acceleration of the pinion.

$$\begin{aligned} \alpha_p &= \alpha_G(N_G/N_p) \\ &= 2.44 \text{ rad/s}^2 \end{aligned}$$

8.) Calculation of applied torque on the pinion.

$$\begin{aligned} T_p &= J_p\alpha_p \\ &= 0.18 \text{ Nm} \end{aligned}$$

* NOTE: Using a factor of safety of 2, $T_p = 0.36 \text{ Nm}$.

- 9.) Calculation of the pinion RPM.

$$\begin{aligned}\text{Pinion RPM} &= \omega(N_G/N_P)(60/2\pi) \\ &= 46.6\end{aligned}$$

VERTICAL CALCULATIONS

- 1.) Calculation of applied torque on the ball screw nut.

$$\begin{aligned}T_{BN} &= WL/2\pi\eta \\ &= 6.7 \text{ Nm}\end{aligned}$$

Where W is equal to the combined weight of the load, turntable bearing, mounting structure, arm, ball screw nut, and ball spline nut, L is the lead of the ball screw nut, and η is the ball screw efficiency.

* NOTE: Formula supplied by NSK Corporation.

- 2.) Calculation of applied torque on the servo.

$$\begin{aligned}T_S &= T_{BN}(D_S/D_{BN}) \\ &= 1.3 \text{ Nm}\end{aligned}$$

Where D is the pulley diameter.

* NOTE: Using a factor of safety of 2, $T_S = 2.6 \text{ Nm}$.
5:1 pulley diameter ratio is assumed.

- 3.) Calculation of ball nut RPM.

$$\begin{aligned}\text{Ball Nut RPM} &= V(60/L) \\ &= 180 \text{ RPM}\end{aligned}$$

Where L is the ball screw nut lead.

- 4.) Calculation of the servo RPM.

$$\begin{aligned}\text{Servo RPM} &= \text{RPM}_{BN}(D_{BN}/D_S) \\ &= 900 \text{ RPM}\end{aligned}$$

Where D_{BN}/D_S is the pulley diameter ratio.

APPENDIX D
COST ESTIMATES

Cost Estimates

Ball Screw/Ball Spine Shaft	\$ 4,036
Spline Nut	332
Screw Nut	565
Turntable Bearing	1,600
Electric Motors (2)	≈125
 Aluminum Central Mounting Structure	
Material	≈100
Machine Labor	≈125
(12) 11 mm dia. bolts?	≈8
(4) 10 mm dia. bolts	≈4
(25) 6 mm dia.	≈15
 Cable Reel (spring rewind)	 279
 Lower Support Boot	 ≈150
 Motor Pulley	 ≈6
Ball Nut Pulley	≈8
Pulley Belt	≈5
Rotational Pinion	≈6
(8) ? mm dia. bolts & nuts (electric motors)	≈6
Mounting Bracket for Ball Screw Electric Motor	≈35
(4) 10 mm bolts for Mounting Bracket	≈4
 Total Estimated Cost	 \$ ≈7,400

APPENDIX E
WEIGHT ESTIMATES

Weight Estimates

Ball Screw/Ball Spine Shaft	23.2
Spline Nut	5.45
Screw Nut (2)	12.7
Turntable Bearing	18.2
Electric Motors (2)	≈8.16
Aluminum Central Mounting Structure	≈15
Cable Reel	11.8
Bolts and Nuts	≈0.91
Pulleys	≈0.91
Mounting Bracket	≈0.45
Gear	≈0.45
 Total Weight Estimation	 ≈97 kg

APPENDIX F
SPECIFICATIONS
UCF-SPEC-393

1.0 SCOPE

1.1 Scope This specification defines the system performance and operational constraints for the design, building, and testing of the Controlled Ecological Life Support System (CELSS) robot. The performance and requirements were developed in accordance with established standards and requirements in documents described in section 2.0.

1.2 Background T.B.D.

2.0 APPLICABLE DOCUMENTS

2.1 Specifications

2.1.1 Federal, None

2.1.2 Military, None

2.1.3 NASA

2.1.3.1 KSC-SPEC-Z-009, Lubrication, Thread, Corrosion-Resistant Steel and Aluminum Alloy Tube Fittings, Specification for, Ref. 3.3.3.3.5.

2.1.3.2 NBS Handbook 105-1, Specifications and Tolerances for Reference Standards and Field Standard Weights and Measures, Ref. 3.3.5.6.f.

2.1.3.3 NSS GO 1740.9, NASA Safety Standard for Lifting Devices and Equipment, Ref. 3.3.1.4.b, 3.3.2.2.h, 4.2.1.

2.1.3.4 KSC-STD-141, Load Test, Identification and Data Marking, Standard For, Ref. 3.3.5.2., 4.2.1.

2.1.3.5 KSC-STD-E-0012, Bonding and Grounding, Standard For, Ref. 3.3.1.5.b.

2.1.3.6 29 CFR (Part 1910), Occupational Safety and Health Administration, Labor (Occupational Safety and Health Standards), Ref. 3.3.2.1.d, 3.3.2.2.a, 3.3.5.4, 3.3.8, 3.3.9.2.

2.1.3.7 MIL-STD-109, Quality Assurance Terms and Definitions, Ref. 4.3.e.

2.1.3.8 MIL-STD-794, Parts and Equipment, Procedures for Packaging of, Ref. 5.1.

- 2.1.3.9 KHB 1710.2, Kennedy Space Center Safety Practices Handbook, Ref. 3.3.8.
- 2.1.3.10 KHB 5310.1, Kennedy Space Center Reliability and Quality Assurance Handbook, Ref. 3.2.3, 4.
- 2.1.3.11 KHB 5310.9, Grounds Systems Safety and Reliability Analyses, Ref. 3.2.3, 3.3.8.
- 2.1.3.12 GP-425, Engineering Standards, Ref. 3.3.3.2.3.
- 2.1.3.13 KMI 5310.9, Kennedy Space Center Ground Systems Safety and Reliability Analyses, Ref. 3.2.3.
- 2.1.3.14 KMI 5320.4, NASA Standard Parts Program, Ref. 3.3.3.2.2.
- 2.1.3.15 KMI 5350.1, Kennedy Space Center Maintainability Program, Ref. 3.2.4.
- 2.1.3.16 ANSI/NFPA 70, National Electrical Code, Ref. 3.2.5.6.
- 2.1.3.17 MIL-STD-1629A, Procedures for Performing a Failure Mode Effects and Criticality Analysis.
- 2.1.3.18 NFPA 43-C, Storage of Gaseous Oxidizing Materials, 1986.
- 2.1.3.19 NFPA 49, Hazardous Chemical Data, 1991.
- 2.1.3.20 NFPA 325M, Fire Hazard Properties of Flammable Liquids, Gases and Volatile Solids.
- 2.1.3.21 KSC-DE-512-SM Facility, System, and Equipment, General Design Requirements.

2.1.4 Contractor, None.

2.2 Standards

2.2.1 Federal

2.2.1.1 ANSI (American National Standards Institute)

- 2.2.1.1.1 ANSI approved RIA (Robotic Industries Association) Safety Standard for Industrial Robots and Robot Systems.

2.2.1.2 ASTM (American Society for Testing and Materials)

2.2.1.3 ASME (American Society of Mechanical Engineers)

2.2.1.4 ASM

2.2.2 Military, None.

2.2.3 NASA, None.

2.2.4 Contractor, None.

2.3 Drawings, None.

2.4 Bulletins, None.

2.5 Other Documents

2.5.1 Manuals, None.

2.5.2 Handbooks, None.

2.5.3 Textbooks

2.5.3.1 1992 Annual Book of ASTM Standards, ASTM, Philadelphia, 1992.

2.5.3.2 Boyer, Howard E. and Gall, Timothy L. , Metals Handbook Desk Edition, American Society for Metals, Metals Park, Ohio, 1990.

3.0 REQUIREMENTS

3.1 Definitions The following requirements shall be incorporated into the design and construction of the CELSS robot.

3.2 Performance Requirements

3.2.1 General Performance Requirements

3.2.1.1 Environmental Effects on Robot

3.2.1.1.1 All materials shall be protected from corrosion.

3.2.1.1.2 Electrical components shall be protected from weathering and corrosion.

3.2.1.1.3 Actuators and joints shall be protected from corrosion.

3.2.1.2 Installation

3.2.1.2.1 Technicians shall be required to be certified.

3.2.1.3 Modification

3.2.1.3.1 Any and all modifications shall maintain the integrity of the CELSS environment as a whole.

3.2.1.3.2 All modifications shall be minimized.

3.2.1.4 Performance Reliability

3.2.1.4.1 Robot shall meet reliability standards as determined by Kennedy Space Center.

3.2.1.4.2 Robot shall perform with the necessary level of accuracy and precision.

3.2.1.5 Safety

3.2.1.5.1 Mechanical safety components shall be provided.

3.2.1.5.2 Electrical safety components shall be provided.

3.2.1.5.3 Safety systems shall be integrated with robot control systems.

3.2.1.5.4 Intrinsic safety features shall be provided within design.

3.2.1.5.5 Warning devices shall be provided.

3.2.1.5.6 Provide warning sign, in clear view, at single entry door indicating layout of chamber and robot limits of reach.

3.2.1.5.7 Provide equipment labelling to indicate hazards.

3.2.1.6 Standardization

3.2.1.6.1 All applicable hardware shall meet the standards specified here in.

3.2.1.6.2 All replaceable/interchangeable parts shall meet the standards specified in the original drawings.

3.2.1.6.3 The use of off the shelf parts shall be maximized.

3.2.2 Specific Performance Requirements

3.2.2.1 Environmental Effects on Robot

3.2.2.1.1 The materials used shall be capable of operating in an environment with a maximum relative humidity of 85% and a minimum pH of 5.7.

3.2.2.1.2 The electrical components shall be capable of operating in an environment with a maximum relative humidity of 85% and a temperature range of 10-160 C.

3.2.2.1.3 The actuators and joints used shall be capable of operating in an environment with a maximum relative humidity of 85% and a minimum pH of 5.7.

3.2.2.2 Installation

3.2.2.2.1 Courses required for technicians shall be torque and tubing, electrical mate/demate of cables, and electrical bonding.

3.2.2.3 Modification

3.2.2.3.1 All modifications shall maintain the individual integrity of the upper and lower CELSS chambers.

3.2.2.3.2 All proposed modifications shall be reviewed before implementation.

3.2.2.4 Performance Reliability

3.2.2.4.1 The robot shall withstand T.B.D. breakdowns and operate as specified.

3.2.2.4.2 The range of accuracy along any axis shall be no less than 0.635 cm.

3.2.2.5 Safety

- 3.2.2.5.1 Mechanical safety components such as microswitches and mechanical stops shall be provided.
- 3.2.2.5.2 A regular operation electric circuit interlocked with the emergency "Off" button and an uninterrupted emergency power circuit to return the robot to its failsafe location shall be provided.
- 3.2.2.5.3 An operation sequence for emergency power operation, oxygen level sensors, and control sequence to notify KSC of excess oxygen if oxygen levels exceed T.B.D. levels, shall be provided.
- 3.2.2.5.4 Smooth design lines, built in hose/cable routes with waterproofing and drip loops, drive mechanism covers shall be provided.
- 3.2.2.5.5 Provide robotics systems status light and emergency "Off" (panic) button.
- 3.2.2.5.6 Warning signs shall be plastic laminate, minimum T.B.D. dimensions, red background, with letters of T.B.D. size.
- 3.2.2.5.7 Label pinch points, proper equipment mounting points, and power supply as possible hazards.

3.2.2.6 Standardization

- 3.2.2.6.1 All applicable hardware shall be annotated in all documentation according to ASTM, ASME, ASM, or ANSI standards.
- 3.2.2.6.2 All replaceable/interchangeable parts shall be visibly designated with markings corresponding to specifications denoted on original drawings.
- 3.2.2.6.3 Before ordering/fabrication of any parts, investigate the availability of the item as an off the shelf part.

3.3 Operational Requirements

3.3.1 General Operational Requirements

3.3.1.1 Environmental Effects on Robot

3.3.1.1.1 All systems shall maintain integrity throughout their operational life.

3.3.1.2 Modification

3.3.1.2.1 All modifications shall be subject to the approval.

3.3.1.2.2 Any and all modifications shall have minimum structural and functional impact on the existing CELSS unit.

3.3.1.3 Operational Reliability

3.3.1.3.1 Preventive maintenance shall be performed on a regular basis.

3.3.1.4 Safety

3.3.1.4.1 A design for reduction of kinetic energy shall be provided.

3.3.1.4.2 A means to expend excess kinetic energy shall be provided.

3.3.1.4.3 Safety training shall be provided.

3.3.1.4.4 A safe power "on" procedure shall be provided.

3.3.1.4.5 A safe power "off" procedure shall be provided.

3.3.1.5 Standardization

3.3.1.5.1 All applicable hardware shall meet the standards specified on the design drawings.

3.3.2 Specific Operational Requirements

3.3.2.1 Environmental Effects on Robot

3.3.2.1.1 Electrical and mechanical systems shall operate as designed under specified conditions.

3.3.2.2 Modifications

3.3.2.2.1 All modifications shall be subject to approval of T.B.D. at the University of Central Florida, College of Engineering and Kennedy Space Center.

3.3.2.2.2 All modifications shall not hinder the function nor impede the access of technical support personnel to the CELSS unit.

3.3.2.3 Operational Reliability

3.3.2.3.1 A T.B.D. preventative maintenance schedule shall be provided.

3.3.2.4 Safety

3.3.2.4.1 Component design and location shall minimize stress in structural members and fasteners.

3.3.2.4.2 Provide mechanical stops, shock absorbers, and spring type components for conversion of kinetic energy to potential energy.

3.3.2.4.3 Classes and manuals on standard safety procedures shall be provided.

3.3.2.4.4 A second person with their hand on the emergency "off" button shall be provided.

3.3.2.4.5 Equipment shall be tagged as being out of service and circuit breakers to main power shall be locked in "off" position.

3.3.2.5 Standardization

3.3.2.5.1 The following hardware shall meet the standards specified herein: T.B.D.

4.0 VERIFICATIONS

4.1 Definition. The following tests and verification procedures shall be used to verify the requirements and specifications of the CELSS robot as set forth in the document.

4.2 Performance Verifications

4.2.1 General Performance Verifications

4.2.1.1 Environmental Effects on Robot

4.2.1.1.1 Verify corrosion resistance by a simulated test at the most extreme CELSS environment for T.B.D. hours.

4.2.1.1.2 Verify electrical component protection by a simulated test at the most extreme CELSS environment for T.B.D. hours.

4.2.1.1.3 Verify actuators and joints integrity by a simulated test at the most extreme CELSS environment for T.B.D. hours.

4.2.1.2 Installation

4.2.1.2.1 Before performing any integration, all technicians shall show their certification card to the Task Leader.

4.2.1.3 Modification

4.2.1.3.1 Visually inspect any "through" chamber connections have been sealed.

4.2.1.3.2 All modifications must be reviewed and approved by Kennedy Space Center prior to implementation.

4.2.1.4 Performance Reliability

4.2.1.4.1 Verify reliability by performing T.B.D. tests on all system components.

4.2.1.4.2 Measurement tests shall be performed to insure a T.B.D. range of accuracy and precision.

4.2.1.5 Safety

4.2.1.5.1 Verify mechanical safety components by testing and measuring for compliance with specified performance standards and tolerances.

4.2.1.5.2 Verify electrical safety components by testing for compliance with specified performance standards.

4.2.1.5.3 Test safety modes and functions for coordination with existing control systems.

4.2.1.5.4 A close out inspection shall be performed. Inspection shall verify smooth design lines, pinch point protection/label, and interlock disconnects.

4.2.1.5.5 Verify location and operation of additional safety devices.

4.2.1.5.6 Visually inspect warning sign for compliance with specifications.

4.2.1.5.7 Visually inspect labelling for compliance with specification.

4.2.1.6 Standardization

4.2.1.6.1 Visually inspect hardware for ASTM, ASME, ASM, or ANSI standard markings.

4.2.1.6.2 Parts tags from replaceable/interchangeable items shall be correlated to original part tags and should include model number.

4.2.1.6.3 Confirm the unavailability of an item with logistics before ordering/fabricating any parts.

4.3 Operational Verification.

4.3.1 General Operational Verifications

4.3.1.1 Environmental Effects on Robot

4.3.1.1.1 Visually inspect and run tests for stress cracks, fatigue, corrosion, and wear.

4.3.1.2 Modification

4.3.1.2.1 Verify approval is obtained from the departments before any modifications are implemented.

4.3.1.2.2 Verify Field Engineering Change has been approved before any modifications are implemented.

4.3.1.3 Performance Reliability

4.3.1.3.1 Verify that a schedule for maintenance is devised, in addition to regular inspection between maintenance periods.

4.3.1.4 Safety

4.3.1.4.1 Verify that locations of components are properly designed to reduce kinetic energy by performing a kinematic analysis of the system.

4.3.1.4.2 Test mechanical stops, shock absorbers, and spring type components for conversions of kinetic energy to potential energy.

4.3.1.4.3 Observe standard safety classes and review manuals.

4.3.1.4.4 Verify power "on" service procedures are followed.

4.3.1.4.5 Verify power "off" service procedures are followed.

4.3.1.5 Standardization

4.3.1.5.1 All parts used on CELSS shall be verified before use by comparing the part number tags to the original design drawings. All parts tags shall be attached to documentation after parts are used.

5.0 NOTES

5.1 Responsible Engineering Office

5.1.1 The office responsible for development and technical maintenance of this specification is University of Central Florida, Aeronautical Design I, EAS 4700.

APPENDIX G

STATIC ARM DEFLECTIONS UNDER LOAD

PRECEDING PAGE BLANK NOT FILMED

297

PAGE 296 INTENTIONALLY BLANK

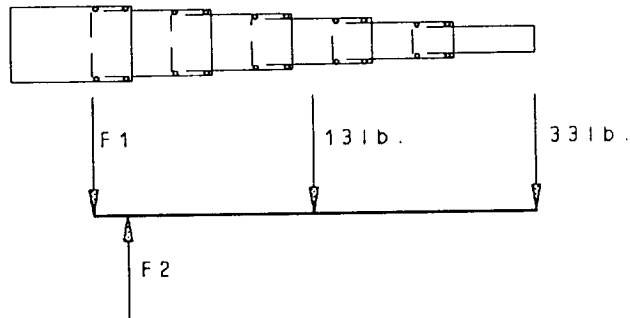

$$\sum F = 0$$

$$F2 - F1 - 13 \text{ lb.} - 33 \text{ lb.} = 0$$

$$F1 = F2 - 46 \text{ lb.}$$

$$F1 = 297 \text{ lb.} - 46 \text{ lb.}$$

$$F1 = 251 \text{ lb. TOTAL}$$

$$F1 = 125.5 \text{ lb. PER ROLLER}$$

$$\sum M = 0$$

$$F1(0) - F2(8 \text{ in}) + 13(36 \text{ in}) + 33(72 \text{ in})$$

$$F2 = 355.5 \text{ lb. TOTAL}$$

$$F2 = 177.8 \text{ lb. PER ROLLER}$$

APPENDIX G.1 Static Force and Moment Analysis

APPENDIX H
CALCULATIONS FOR ROLLING FRICTION

CALCULATIONS FOR ROLLING FRICTION

Coefficient of Rolling Friction, $f_r = P / L$

L = Load

P = Frictional resistance

$$P = (K + K') L/D$$

K = K' = 0.001 (surfaces well - finished and clean)

$$L = 250 \text{ lb}$$

$$d = 0.75 \text{ in}$$

$$P = (0.001) * (2) * (250 \text{ lb}) / (0.75 \text{ in}) = 0.667$$

$$f_r = (0.667) / (250) = 0.0027$$

APPENDIX I
SHEAR FORCE AND MOMENT SPREADSHEET

~~PREVIOUS PAGE BLANK NOT COUNTED~~

CELSS ROBOT DESIGN
 STATIC AND KINEMATIC ANALYSIS

THIS SPREADSHEET IS USED TO GENERATE SHEAR AND MOMENT DIAGRAMS
 FIFTEEN KILOGRAM PAYLOAD

SHEAR DIAGRAM

X (mm)	Y (N)
00.00	253.69
76.26	205.92
305.03	187.87
533.81	177.08
762.58	167.66
1067.62	159.52
1372.65	152.65
1677.68	147.15
1830.20	147.15
1830.20	00.00

MOMENT DIAGRAM

X	Y
00.00	-297.12
76.26	-279.65
305.03	-234.56
533.81	-192.77
762.58	-153.30
1067.62	-115.84
1372.65	-68.23
1677.68	-22.51
1830.20	00.00

APPENDIX J
COMPARISON OF TORSIONAL RESISTANCE

COMPARISON OF TORSIONAL RESISTANCE FOR THE MODEL MEMBER AND THE ACTUAL MEMBER.

Though telescoping pieces were modelled as hollow round tubes, the actual pieces will be rectangular tubes. The largest outer dimension is 164 mm. The rectangular tubes, which have a closed form like the circle tubes, will have a torsional resistance equal to or greater than the round models. Resistance to deflection will be improved over the model of the round telescoping pieces because of the higher value of EI. As the value of the moment of inertia, I, is increased, the value of the deflection, δ , is decreased.

$$\delta = \frac{F \cdot L^3}{3 \cdot E \cdot I}$$

δ =Vertical Deflection
E= Young's Modulus

F=Force L=Length
I=Moment of Inertia

APPENDIX K

CALCULATIONS FOR ALLOWABLE LOAD PER ROLLER BEARING

CARRYING CAPACITY OF ROLLER BEARINGS

Reference: Ball and Roller Bearing Engineering, Third Edition, Arvid Palmgren, Engng. Copyright SKF Industry, Inc. Philadelphia, PA, 1959. Printed S. H. Burbank and Company, Inc. Philadelphia, PA.

$$f_c = v \lambda g_c f_1 f_2$$

$$g_c = (1 + (C_i/C_e)^{9/2})^{-2/9}$$

$$C_i/C_e = f_3$$

Table 3.2, page 80. For radial roller bearings

$$f_1 = 21.2$$

f_1 coefficient depends on the distribution of the forces in the bearing and on the properties of the material.

$$f_2 = \frac{y^{45} (1-y)^{27}}{(1+y)^{25}}$$

dm = Pitch circle diameter

$$f_3 = 1.04 * [(1 - y) / (1 + y)]^{143 / 108}$$

Dw = Roller Diameter

$$y = [Dw \cos(CX)] / dm$$

CX = 0, Assumed contact angle

$$v = 1.36$$

$$\lambda = 1.04$$

$$dm = 3.97 \text{ mm}$$

$$Dw = 1.79 \text{ mm}$$

$$CX = 90^\circ$$

$$y = \frac{(1.79 \text{ mm}) \times (\cos 90)}{(3.97 \text{ mm})} = .4509(\text{unitless})$$

Reference: Ball and Roller Bearing Engineering, Third Edition, Arvid Palmgren, Engrg. Copyright SKF Industry, Inc. Philadelphia, PA, 1959. Printed S. H. Burbank and Company, Inc. Philadelphia, PA.

$$C_i/C_e = f_3 = 1.04 * [(1 - y) / (1 + y)]^{143 / 108} = 0.2873$$

$$g_c = (1 + (C_i/C_e)^{9/2})^{-2/9} = [1 + (0.2873)^{4.5}]^{-0.2222} = 0.99919$$

$$f_2 = \frac{y^{2/8} (1-y)^{29/27}}{(1+y)^{25}} = \frac{(0.4509)^{0.2222} (0.5491)^{1.07407}}{(1.4509)^{25}} = 0.401$$

$$f_c = (1.36)(0.45)(0.99919)(21.2)(0.401) = 5.1985$$

Using a roller length 10 mm:

$$C = f_c [(i)(i_a)(\cos CX)]^{7/9} Z^{3/4} D_w^{29/27}$$

$$f_c = 5.199$$

$$i = 1$$

$$i_a = 10 \text{ mm}$$

$$CX = 90 \text{ degrees}$$

$$Z = 6$$

$$D_w = 1.79 \text{ mm}$$

$$C = (5.199)[(1)(10 \text{ mm})(1.00)]^{0.7778}(6)^{0.75}(1.79 \text{ mm})^{1.07407}$$

$$C = 223.3 \text{ kg} = 2190 \text{ N}$$

$$C = 2190 \text{ N} / 2 \text{ F.S.} = 1095$$

From shear and moment diagrams for the rollers given in the preliminary design, the maximum force the rollers will experience is 792 N.

APPENDIX L
SUMMARY OF COMPUTER ANALYSIS

Summary of Computer Analysis

Maximum Deflection of Shaft	0.467 mm
Maximum Stress in Shaft	16.979 MPa
Maximum Von Mises Stress in Shaft	16.9 MPa
Maximum Deflection of Arm	1.31 mm
Maximum Stress in Arm	5.222 MPa

Summary of Engineering Calculations

Maximum Deflection of Shaft	3.53 mm
Maximum Stress in Shaft	16.0 MPa
Maximum Deflection of Arm	1.71 mm
Maximum Stress in Arm	5.27 MPa

NOTE: Stress and deflection of arm were based upon the largest cross section over the entire length of the arm.

APPENDIX M
DATA FROM COMPUTER ANALYSIS

Mass Properties of Telescoping Robot Arm

Program: SDRC I-DEAS VI: Solid_Modeling

File : armprop

Object : 1-WORK1, {LINK4, Bin1} (Mod)

Date : 15-APR-94 14:57:10

Modified_SI mm sec kilogram(kgm) milli-newton deg_C:KC:K

Surface area - Total : 1.825547E+06 mm²

Volume : 2.716958E+06 mm³

Density : 2.700000E-06 kg/mm³

Mass : 7.335787 kg

Center of gravity: 700.0828 mm 0.0 0.0
from the center of the ball shaft.

Moments of inertia about C.G.:

IXX, IYY, IZZ : 38266.82 2.225817E+06 2.224934E+06

IXY, IYZ, IXZ : 0.0 0.0 0.0

Moments of inertia about the origin:

IXX, IYY, IZZ : 38266.82 5.821203E+06 5.820320E+06

IXY, IYZ, IXZ : 0.0 0.0 0.0

Principal axis :

1 X, Y, Z : 1.000000 0.0 0.0

2 X, Y, Z : 0.0 0.0 1.000000

3 X, Y, Z : 0.0 -1.000000 0.0

323

Principal moments of inertia about C.G.:

I11, I22, I33 : 38266.82 2.224934E+06 2.225817E+06

Displacement Data for Ball Screw/Shaft

SDRC I-DEAS VI: FE_Modeling_&_Analysis 20-APR-94 12:51:47

Group ID : No stored PERMANENT GROUP
Analysis Dataset : 1 - CASE 1,LOAD 1,DISPLACEMENTS
Report Type : Deformed Geometry Units : MM
Dataset Type : Displacements Load Set : 1

Node	Trans-X	Trans-Y	Trans-Z	Rot-X	Rot-Y	Rot-Z
1	0.000E+00	0.000E+00	0.000E+00	0.000E+00	0.000E+00	8.106E-04
2	-8.080E-02	4.619E-05	0.000E+00	0.000E+00	0.000E+00	7.998E-04
3	-1.594E-01	9.237E-05	0.000E+00	0.000E+00	0.000E+00	7.674E-04
4	-2.337E-01	1.386E-04	0.000E+00	0.000E+00	0.000E+00	7.132E-04
5	-3.016E-01	1.847E-04	0.000E+00	0.000E+00	0.000E+00	6.375E-04
6	-3.607E-01	2.309E-04	0.000E+00	0.000E+00	0.000E+00	5.401E-04
7	-4.091E-01	2.771E-04	0.000E+00	0.000E+00	0.000E+00	4.211E-04
8	-4.444E-01	3.233E-04	0.000E+00	0.000E+00	0.000E+00	2.804E-04
9	-4.646E-01	3.695E-04	0.000E+00	0.000E+00	0.000E+00	1.181E-04
10	-4.675E-01	4.157E-04	0.000E+00	0.000E+00	0.000E+00	-6.591E-05
11	-4.509E-01	4.619E-04	0.000E+00	0.000E+00	0.000E+00	-2.715E-04
12	-4.127E-01	5.081E-04	0.000E+00	0.000E+00	0.000E+00	-4.988E-04
13	-3.506E-01	5.542E-04	0.000E+00	0.000E+00	0.000E+00	-7.477E-04
14	-2.626E-01	6.004E-04	0.000E+00	0.000E+00	0.000E+00	-1.018E-03
15	-1.465E-01	6.466E-04	0.000E+00	0.000E+00	0.000E+00	-1.310E-03
16	-1.935E-06	6.928E-04	0.000E+00	0.000E+00	0.000E+00	-1.624E-03
17	1.465E-01	6.466E-04	0.000E+00	0.000E+00	0.000E+00	-1.310E-03
18	2.626E-01	6.004E-04	0.000E+00	0.000E+00	0.000E+00	-1.018E-03
19	3.506E-01	5.542E-04	0.000E+00	0.000E+00	0.000E+00	-7.477E-04
20	4.127E-01	5.081E-04	0.000E+00	0.000E+00	0.000E+00	-4.988E-04
21	4.509E-01	4.619E-04	0.000E+00	0.000E+00	0.000E+00	-2.715E-04
22	4.675E-01	4.157E-04	0.000E+00	0.000E+00	0.000E+00	-6.591E-05
23	4.646E-01	3.695E-04	0.000E+00	0.000E+00	0.000E+00	1.181E-04
24	4.444E-01	3.233E-04	0.000E+00	0.000E+00	0.000E+00	2.804E-04
25	4.091E-01	2.771E-04	0.000E+00	0.000E+00	0.000E+00	4.211E-04

26	3.607E-01	2.309E-04	0.000E+00	0.000E+00	0.000E+00	5.401E-04
27	3.016E-01	1.847E-04	0.000E+00	0.000E+00	0.000E+00	6.375E-04
28	2.337E-01	1.386E-04	0.000E+00	0.000E+00	0.000E+00	7.132E-04
29	1.594E-01	9.237E-05	0.000E+00	0.000E+00	0.000E+00	7.673E-04
30	8.080E-02	4.619E-05	0.000E+00	0.000E+00	0.000E+00	7.998E-04
31	0.000E+00	0.000E+00	0.000E+00	0.000E+00	0.000E+00	8.106E-04

	22	16	1	1	1	1
Maximum	<u>4.675E-01</u>	6.928E-04	0.000E+00	0.000E+00	0.000E+00	8.106E-04

	10	1	1	1	1	16
Minimum	-4.675E-01	0.000E+00	0.000E+00	0.000E+00	0.000E+00	-1.624E-03

Average	-1.268E-06	3.352E-04	0.000E+00	0.000E+00	0.000E+00	2.345E-05
---------	------------	-----------	-----------	-----------	-----------	-----------

Combined Stress Data on Ball Screw/Shaft

SDRC I-DEAS VI: FE_Modeling_&_Analysis 20-APR-94 12:49:43
 Combined Stress on Ball Screw/Shaft

Group ID : Current
 Analysis Dataset : 3 - CASE 1,LOAD 1,ELEMENT FORCES
 Report Type : Beam Stress Contour Units : MM
 Dataset Type : Element Forces Load Set : 1
 Data Component : Combined Stress at Maximum Point

Element	Node	Axial	Y-Shear	Z-Shear	Torque	Y-Bend	Z-Bend
1	1	-1.88E+05	-1.37E+05	0.00E+00	0.00E+00	0.00E+00	0.00E+00
1	2	1.88E+05	1.37E+05	0.00E+00	0.00E+00	0.00E+00	-1.37E+07
2	2	-1.88E+05	-1.37E+05	0.00E+00	0.00E+00	0.00E+00	1.37E+07
2	3	1.88E+05	1.37E+05	0.00E+00	0.00E+00	0.00E+00	-2.75E+07
3	3	-1.88E+05	-1.37E+05	0.00E+00	0.00E+00	0.00E+00	2.75E+07
3	4	1.88E+05	1.37E+05	0.00E+00	0.00E+00	0.00E+00	-4.12E+07
4	4	-1.88E+05	-1.37E+05	0.00E+00	0.00E+00	0.00E+00	4.12E+07
4	5	1.88E+05	1.37E+05	0.00E+00	0.00E+00	0.00E+00	-5.49E+07
5	5	-1.88E+05	-1.37E+05	0.00E+00	0.00E+00	0.00E+00	5.49E+07
5	6	1.88E+05	1.37E+05	0.00E+00	0.00E+00	0.00E+00	-6.87E+07
6	6	-1.88E+05	-1.37E+05	0.00E+00	0.00E+00	0.00E+00	6.87E+07
6	7	1.88E+05	1.37E+05	0.00E+00	0.00E+00	0.00E+00	-8.24E+07

7	7	-1.88E+05	-1.37E+05	0.00E+00	0.00E+00	0.00E+00	8.24E+07
7	8	1.88E+05	1.37E+05	0.00E+00	0.00E+00	0.00E+00	-9.61E+07
8	8	-1.88E+05	-1.37E+05	0.00E+00	0.00E+00	0.00E+00	9.61E+07
8	9	1.88E+05	1.37E+05	0.00E+00	0.00E+00	0.00E+00	-1.10E+08
9	9	-1.88E+05	-1.37E+05	0.00E+00	0.00E+00	0.00E+00	1.10E+08
9	10	1.88E+05	1.37E+05	0.00E+00	0.00E+00	0.00E+00	-1.24E+08
10	10	-1.88E+05	-1.37E+05	0.00E+00	0.00E+00	0.00E+00	1.24E+08
10	11	1.88E+05	1.37E+05	0.00E+00	0.00E+00	0.00E+00	-1.37E+08
11	11	-1.88E+05	-1.37E+05	0.00E+00	0.00E+00	0.00E+00	1.37E+08
11	12	1.88E+05	1.37E+05	0.00E+00	0.00E+00	0.00E+00	-1.51E+08
12	12	-1.88E+05	-1.37E+05	0.00E+00	0.00E+00	0.00E+00	1.51E+08
12	13	1.88E+05	1.37E+05	0.00E+00	0.00E+00	0.00E+00	-1.65E+08
13	13	-1.88E+05	-1.37E+05	0.00E+00	0.00E+00	0.00E+00	1.65E+08
13	14	1.88E+05	1.37E+05	0.00E+00	0.00E+00	0.00E+00	-1.79E+08
14	14	-1.88E+05	-1.37E+05	0.00E+00	0.00E+00	0.00E+00	1.79E+08
14	15	1.88E+05	1.37E+05	0.00E+00	0.00E+00	0.00E+00	-1.92E+08
15	15	-1.88E+05	-1.37E+05	0.00E+00	0.00E+00	0.00E+00	1.92E+08
15	16	1.88E+05	1.37E+05	0.00E+00	0.00E+00	0.00E+00	-2.06E+08
16	16	-1.88E+05	-1.37E+05	0.00E+00	0.00E+00	0.00E+00	2.06E+08
16	17	1.88E+05	1.37E+05	0.00E+00	0.00E+00	0.00E+00	-1.92E+08
17	17	-1.88E+05	-1.37E+05	0.00E+00	0.00E+00	0.00E+00	1.92E+08
17	18	1.88E+05	1.37E+05	0.00E+00	0.00E+00	0.00E+00	-1.79E+08
18	18	-1.88E+05	-1.37E+05	0.00E+00	0.00E+00	0.00E+00	1.79E+08
18	19	1.88E+05	1.37E+05	0.00E+00	0.00E+00	0.00E+00	-1.65E+08
19	19	-1.88E+05	-1.37E+05	0.00E+00	0.00E+00	0.00E+00	1.65E+08
19	20	1.88E+05	1.37E+05	0.00E+00	0.00E+00	0.00E+00	-1.51E+08
20	20	-1.88E+05	-1.37E+05	0.00E+00	0.00E+00	0.00E+00	1.51E+08
20	21	1.88E+05	1.37E+05	0.00E+00	0.00E+00	0.00E+00	-1.37E+08
21	21	-1.88E+05	-1.37E+05	0.00E+00	0.00E+00	0.00E+00	1.37E+08
21	22	1.88E+05	1.37E+05	0.00E+00	0.00E+00	0.00E+00	-1.24E+08
22	22	-1.88E+05	-1.37E+05	0.00E+00	0.00E+00	0.00E+00	1.24E+08
22	23	1.88E+05	1.37E+05	0.00E+00	0.00E+00	0.00E+00	-1.10E+08
23	23	-1.88E+05	-1.37E+05	0.00E+00	0.00E+00	0.00E+00	1.10E+08
23	24	1.88E+05	1.37E+05	0.00E+00	0.00E+00	0.00E+00	-9.61E+07
24	24	-1.88E+05	-1.37E+05	0.00E+00	0.00E+00	0.00E+00	9.61E+07
24	25	1.88E+05	1.37E+05	0.00E+00	0.00E+00	0.00E+00	-8.24E+07
25	25	-1.88E+05	-1.37E+05	0.00E+00	0.00E+00	0.00E+00	8.24E+07
25	26	1.88E+05	1.37E+05	0.00E+00	0.00E+00	0.00E+00	-6.87E+07
26	26	-1.88E+05	-1.37E+05	0.00E+00	0.00E+00	0.00E+00	6.87E+07
26	27	1.88E+05	1.37E+05	0.00E+00	0.00E+00	0.00E+00	-5.49E+07
27	27	-1.88E+05	-1.37E+05	0.00E+00	0.00E+00	0.00E+00	5.49E+07
27	28	1.88E+05	1.37E+05	0.00E+00	0.00E+00	0.00E+00	-4.12E+07
28	28	-1.88E+05	-1.37E+05	0.00E+00	0.00E+00	0.00E+00	4.12E+07
28	29	1.88E+05	1.37E+05	0.00E+00	0.00E+00	0.00E+00	-2.75E+07

29	29	1.88E+05	-1.37E+05	0.00E+00	0.00E+00	0.00E+00	-2.75E+07
29	30	-1.88E+05	1.37E+05	0.00E+00	0.00E+00	0.00E+00	1.37E+07
30	30	1.88E+05	-1.37E+05	0.00E+00	0.00E+00	0.00E+00	-1.37E+07
30	31	-1.88E+05	1.37E+05	0.00E+00	0.00E+00	0.00E+00	-2.27E-07
		16	1	1	1	1	15
Maximum		1.88E+05	1.37E+05	0.00E+00	0.00E+00	0.00E+00	2.06E+08
		1	1	1	1	1	1
Minimum		1.88E+05	1.37E+05	0.00E+00	0.00E+00	0.00E+00	0.00E+00
Average		1.88E+05	1.37E+05	0.00E+00	0.00E+00	0.00E+00	1.03E+08

Displacement Data for Telescoping Robot Arm

SDRC I-DEAS VI: FE_Modeling_&_Analysis 20-APR-94 01:55:56
 Displacement Data for Telescoping Robot Arm

Group ID : No stored PERMANENT GROUP
 Analysis Dataset : 1 - LOAD 1, DISPLACEMENTS1
 Report Type : Deformed Geometry Units : MM
 Dataset Type : Displacements Load Set : 1

Node	Trans-X	Trans-Y	Trans-Z	Rot-X	Rot-Y	Rot-Z
1	0.000E+00	0.000E+00	0.000E+00	0.000E+00	0.000E+00	0.000E+00
2	0.000E+00	0.000E+00	0.000E+00	0.000E+00	0.000E+00	0.000E+00
3	0.000E+00	0.000E+00	0.000E+00	0.000E+00	0.000E+00	0.000E+00
4	0.000E+00	0.000E+00	0.000E+00	0.000E+00	0.000E+00	0.000E+00
5	0.000E+00	-2.623E-03	0.000E+00	0.000E+00	0.000E+00	-4.556E-05
6	0.000E+00	-8.157E-03	0.000E+00	0.000E+00	0.000E+00	-8.818E-05
7	0.000E+00	-1.641E-02	0.000E+00	0.000E+00	0.000E+00	-1.278E-04
8	0.000E+00	-2.718E-02	0.000E+00	0.000E+00	0.000E+00	-1.646E-04
9	0.000E+00	-4.027E-02	0.000E+00	0.000E+00	0.000E+00	-1.983E-04
10	0.000E+00	-5.550E-02	0.000E+00	0.000E+00	0.000E+00	-2.292E-04
11	0.000E+00	-7.267E-02	0.000E+00	0.000E+00	0.000E+00	-2.571E-04
12	0.000E+00	-9.366E-02	0.000E+00	0.000E+00	0.000E+00	-3.454E-04
13	0.000E+00	-1.203E-01	0.000E+00	0.000E+00	0.000E+00	-4.271E-04
14	0.000E+00	-1.520E-01	0.000E+00	0.000E+00	0.000E+00	-5.022E-04
15	0.000E+00	-1.883E-01	0.000E+00	0.000E+00	0.000E+00	-5.717E-04

16	0.000E+00	-2.289E-01	0.000E+00	0.000E+00	0.000E+00	-6.366E-04
17	0.000E+00	-2.737E-01	0.000E+00	0.000E+00	0.000E+00	-6.969E-04
18	0.000E+00	-3.223E-01	0.000E+00	0.000E+00	0.000E+00	-7.526E-04
19	0.000E+00	-3.745E-01	0.000E+00	0.000E+00	0.000E+00	-8.036E-04
20	0.000E+00	-4.298E-01	0.000E+00	0.000E+00	0.000E+00	-8.500E-04
21	0.000E+00	-4.880E-01	0.000E+00	0.000E+00	0.000E+00	-8.921E-04
22	0.000E+00	-5.508E-01	0.000E+00	0.000E+00	0.000E+00	-9.840E-04
23	0.000E+00	-6.193E-01	0.000E+00	0.000E+00	0.000E+00	-1.066E-03
24	0.000E+00	-6.930E-01	0.000E+00	0.000E+00	0.000E+00	-1.139E-03
25	0.000E+00	-7.711E-01	0.000E+00	0.000E+00	0.000E+00	-1.202E-03
26	0.000E+00	-8.531E-01	0.000E+00	0.000E+00	0.000E+00	-1.255E-03
27	0.000E+00	-9.392E-01	0.000E+00	0.000E+00	0.000E+00	-1.326E-03
28	0.000E+00	-1.030E+00	0.000E+00	0.000E+00	0.000E+00	-1.381E-03
29	0.000E+00	-1.123E+00	0.000E+00	0.000E+00	0.000E+00	-1.420E-03
30	0.000E+00	-1.218E+00	0.000E+00	0.000E+00	0.000E+00	-1.444E-03
31	0.000E+00	-1.315E+00	0.000E+00	0.000E+00	0.000E+00	-1.452E-03

Maximum 1 1 1 1 1 1
0.000E+00 0.000E+00 0.000E+00 0.000E+00 0.000E+00 0.000E+00 0.000E+00

Minimum 1 31 1 1 1 31
0.000E+00 -1.315E+00 0.000E+00 0.000E+00 0.000E+00 0.000E+00 -1.452E-03

Average 0.000E+00 -3.873E-01 0.000E+00 0.000E+00 0.000E+00 0.000E+00 -6.534E-04

Combined Stress Data on Telescoping Robot Arm

SDRC I-DEAS VI: FE_Modeling_&_Analysis 20-APR-94 02:00:33
Combined Stress on Telescoping Robot Arm

Group ID : Current
Analysis Dataset : 3 - LOAD 1, ELEMENT FORCES3
Report Type : Beam Stress Contour Units : MM
Dataset Type : Element Forces Load Set : 1
Data Component : Combined Stress at Maximum Point

Element	Node	Axial	Y-Shear	Z-Shear	Torque	Y-Bend	Z-Bend
1	1	0.00E+00	0.00E+00	0.00E+00	0.00E+00	0.00E+00	0.00E+00
1	2	0.00E+00	0.00E+00	0.00E+00	0.00E+00	0.00E+00	0.00E+00

2	2	0.00E+00	0.00E+00	0.00E+00	0.00E+00	0.00E+00	0.00E+00
2	3	0.00E+00	0.00E+00	0.00E+00	0.00E+00	0.00E+00	0.00E+00
3	3	0.00E+00	0.00E+00	0.00E+00	0.00E+00	0.00E+00	0.00E+00
3	4	0.00E+00	0.00E+00	0.00E+00	0.00E+00	0.00E+00	0.00E+00
4	4	0.00E+00	3.75E+05	0.00E+00	0.00E+00	0.00E+00	3.95E+08
4	5	0.00E+00	-3.75E+05	0.00E+00	0.00E+00	0.00E+00	-3.70E+08
5	5	0.00E+00	3.75E+05	0.00E+00	0.00E+00	0.00E+00	3.70E+08
5	6	0.00E+00	-3.75E+05	0.00E+00	0.00E+00	0.00E+00	-3.46E+08
6	6	0.00E+00	3.75E+05	0.00E+00	0.00E+00	0.00E+00	3.46E+08
6	7	0.00E+00	-3.75E+05	0.00E+00	0.00E+00	0.00E+00	-3.21E+08
7	7	0.00E+00	3.75E+05	0.00E+00	0.00E+00	0.00E+00	3.21E+08
7	8	0.00E+00	-3.75E+05	0.00E+00	0.00E+00	0.00E+00	-2.96E+08
8	8	0.00E+00	3.75E+05	0.00E+00	0.00E+00	0.00E+00	2.96E+08
8	9	0.00E+00	-3.75E+05	0.00E+00	0.00E+00	0.00E+00	-2.71E+08
9	9	0.00E+00	3.75E+05	0.00E+00	0.00E+00	0.00E+00	2.71E+08
9	10	0.00E+00	-3.75E+05	0.00E+00	0.00E+00	0.00E+00	-2.47E+08
10	10	0.00E+00	3.75E+05	0.00E+00	0.00E+00	0.00E+00	2.47E+08
10	11	0.00E+00	-3.75E+05	0.00E+00	0.00E+00	0.00E+00	-2.22E+08
11	11	0.00E+00	2.42E+05	0.00E+00	0.00E+00	0.00E+00	2.22E+08
11	12	0.00E+00	-2.42E+05	0.00E+00	0.00E+00	0.00E+00	-2.06E+08
12	12	0.00E+00	2.42E+05	0.00E+00	0.00E+00	0.00E+00	2.06E+08
12	13	0.00E+00	-2.42E+05	0.00E+00	0.00E+00	0.00E+00	-1.90E+08
13	13	0.00E+00	2.42E+05	0.00E+00	0.00E+00	0.00E+00	1.90E+08
13	14	0.00E+00	-2.42E+05	0.00E+00	0.00E+00	0.00E+00	-1.74E+08
14	14	0.00E+00	1.70E+05	0.00E+00	0.00E+00	0.00E+00	1.74E+08
14	15	0.00E+00	-1.70E+05	0.00E+00	0.00E+00	0.00E+00	-1.63E+08
15	15	0.00E+00	1.70E+05	0.00E+00	0.00E+00	0.00E+00	1.63E+08
15	16	0.00E+00	-1.70E+05	0.00E+00	0.00E+00	0.00E+00	-1.52E+08
16	16	0.00E+00	1.70E+05	0.00E+00	0.00E+00	0.00E+00	1.52E+08
16	17	0.00E+00	-1.70E+05	0.00E+00	0.00E+00	0.00E+00	-1.40E+08
17	17	0.00E+00	1.70E+05	0.00E+00	0.00E+00	0.00E+00	1.40E+08
17	18	0.00E+00	-1.70E+05	0.00E+00	0.00E+00	0.00E+00	-1.29E+08
18	18	0.00E+00	1.70E+05	0.00E+00	0.00E+00	0.00E+00	1.29E+08
18	19	0.00E+00	-1.70E+05	0.00E+00	0.00E+00	0.00E+00	-1.18E+08
19	19	0.00E+00	1.70E+05	0.00E+00	0.00E+00	0.00E+00	1.18E+08
19	20	0.00E+00	-1.70E+05	0.00E+00	0.00E+00	0.00E+00	-1.07E+08
20	20	0.00E+00	1.47E+05	0.00E+00	0.00E+00	0.00E+00	1.07E+08
20	21	0.00E+00	-1.47E+05	0.00E+00	0.00E+00	0.00E+00	-9.71E+07
21	21	0.00E+00	1.47E+05	0.00E+00	0.00E+00	0.00E+00	9.71E+07
21	22	0.00E+00	-1.47E+05	0.00E+00	0.00E+00	0.00E+00	-8.74E+07
22	22	0.00E+00	1.47E+05	0.00E+00	0.00E+00	0.00E+00	8.74E+07
22	23	0.00E+00	-1.47E+05	0.00E+00	0.00E+00	0.00E+00	-7.77E+07
23	23	0.00E+00	1.47E+05	0.00E+00	0.00E+00	0.00E+00	7.77E+07
23	24	0.00E+00	-1.47E+05	0.00E+00	0.00E+00	0.00E+00	-6.80E+07

24	24	0.00E+00	1.47E+05	0.00E+00	0.00E+00	0.00E+00	6.80E+07
24	25	0.00E+00	-1.47E+05	0.00E+00	0.00E+00	0.00E+00	-5.83E+07
25	25	0.00E+00	1.47E+05	0.00E+00	0.00E+00	0.00E+00	5.83E+07
25	26	0.00E+00	-1.47E+05	0.00E+00	0.00E+00	0.00E+00	-4.86E+07
26	26	0.00E+00	1.47E+05	0.00E+00	0.00E+00	0.00E+00	4.86E+07
26	27	0.00E+00	-1.47E+05	0.00E+00	0.00E+00	0.00E+00	-3.88E+07
27	27	0.00E+00	1.47E+05	0.00E+00	0.00E+00	0.00E+00	3.88E+07
27	28	0.00E+00	-1.47E+05	0.00E+00	0.00E+00	0.00E+00	-2.91E+07
28	28	0.00E+00	1.47E+05	0.00E+00	0.00E+00	0.00E+00	2.91E+07
28	29	0.00E+00	-1.47E+05	0.00E+00	0.00E+00	0.00E+00	-1.94E+07
29	29	0.00E+00	1.47E+05	0.00E+00	0.00E+00	0.00E+00	1.94E+07
29	30	0.00E+00	-1.47E+05	0.00E+00	0.00E+00	0.00E+00	-9.71E+06
30	30	0.00E+00	1.47E+05	0.00E+00	0.00E+00	0.00E+00	9.71E+06
30	31	0.00E+00	-1.47E+05	0.00E+00	0.00E+00	0.00E+00	9.09E-07

		1	4	1	1	1	4
Maximum		0.00E+00	3.75E+05	0.00E+00	0.00E+00	0.00E+00	3.95E+08
		1	1	1	1	1	1
Minimum		0.00E+00	0.00E+00	0.00E+00	0.00E+00	0.00E+00	0.00E+00
Average		0.00E+00	2.00E+05	0.00E+00	0.00E+00	0.00E+00	1.39E+08