

11141

N95-17556

225-14
31961
P-8

ADVANCED GROUND STATION ARCHITECTURE

David Zillig (NASA GSFC/Code 531.2)
Ted Benjamin (Stanford Telecomm, Reston, VA)

ABSTRACT

This paper describes a new station architecture for NASA's Ground Network (GN). The architecture makes efficient use of emerging technologies to provide dramatic reductions in size, operational complexity, and operational and maintenance costs. The architecture, which is based on recent receiver work sponsored by the Office of Space Communications Advanced Systems Program, allows integration of both GN and Space Network (SN) modes of operation in the same electronics system. It is highly configurable through software and the use of Charged Coupled Device (CCD) technology to provide a wide range of operating modes. Moreover, it affords modularity of features which are optional depending on the application. The resulting system incorporates advanced RF, digital, and remote control technology capable of introducing significant operational, performance, and cost benefits to a variety of NASA communications and tracking applications.

INTRODUCTION

The NASA Ground Network (GN) station architecture has been used very successfully over the last 25 years to support a multitude of low earth orbiters (LEO's), expendable launch vehicles (ELV's), geosynchronous (GEO's) and lunar missions in the Spaceflight Tracking and Data Network (STDN). The GN RF subsystem, based on the Multifunction, polarization diversity Receiver (MFR) and the STDN tone ranging equipment, still provides extensive support to NASA programs. This support includes: (1) Shuttle launch and landing at GN stations; (2) LEO's, including Small Explorer spacecraft at the DSN 26-meter subnet stations; (3) TDRS GEO spacecraft at the GN, DSN 26-meter subnet, and GRO Remote Terminal System (GRTS) stations. Its hardware has been upgraded and replaced over the years to maintain its ability to provide reliable support to

NASA's critical missions, but its basic architecture remains the same as when the STDN was formed in the early 70's from the Space Tracking and Data Acquisition Network (STADAN) and the Apollo Manned Space Flight Network (MSFN).

While individual functional blocks have been and could continue to be replaced by modern electronics, it is expected that the biggest gains will result from developing a new system architecture that makes the most efficient use of emerging technologies for the most dramatic reductions in size, operational complexity, and operational and maintenance costs.

During the past year, GSFC/Code 531 has been studying new ground station architectures capable of high levels of hardware integration. The architecture incorporates flexible software configurability for implementation of a wide range of modes, and is designed specifically for effective automation of most operational and maintenance functions. The hardware systems are designed to mate with the overall station control philosophy of the Automated Ground Network System (AGNS). AGNS is based on an open architecture comprised of loosely coupled station subsystems (such as the RF subsystem of concern here) that maximize the use of commercial standards and interfaces.

A highly integrated, automated ground station with the capability of meeting stringent Shuttle S-Band communications and tracking requirements can also serve as the next generation near-earth-to-lunar, multipurpose ground terminal. It also lends itself to applications requiring compact, transportable systems and remotely controlled stations that supply direct downlinks to small satellite experimenters.

This paper briefly reviews current GN station architectures and hardware configurations. It then presents functional and signal processing requirements for the upgrade RF subsystem. The advanced station architecture is then described, followed by sections detailing the flexible advanced

888

equipment that support this new station architecture.

CURRENT STATION ARCHITECTURE

The current GN station RF equipment is primarily comprised of what is referred to as the RER -- Reciver, Exciter, Range equipment. As configured today, these three basic functions are distinct equipments, each associated with a dedicated rack of electronics. For example, the MFR receiver consists of a 7' rack containing 7 equipment drawers or modules. The exact hardware configuration varies from station to station depending on specific requirements. A typical RER equipment group is comprised of about 6-7 equipment racks to support a user satellite link.

The GN station antenna system provides a sum signal (Σ) and two error signals (X and Y) in each of two orthogonal polarizations ---- resulting in six receiver input channels. The MFR performs optimal ratio combining of these orthogonal polarized signals and, thus, is referred to as a polarization diversity receiver. Experience has shown that this is a critical GN function that allows continuous operations even through significant fades of the polarized signal that is dominant through most of a pass. To accomplish this processing, and provide redundancy to meet stringent reliability requirements, 4-5 MFRs are typically used (each MFR requiring a rack of equipment) to support user services.

As noted above, substantial equipments are currently required to meet GN mission requirements. This, coupled with the fact that the underlying processing architecture is more than 20 years old, places a substantial burden on GN operations and maintenance. This situation is exasperated as the GN stations are called upon to support new and expanded requirements as user mission needs evolve.

DESIGN GOALS/REQUIREMENTS

General requirements and design goals are first presented. Key receiver, ranging, and transmit requirements are then discussed, in turn.

General Requirements. Except for some few obsolete requirements (e.g., FM Uplink), the RER Upgrade must support all current RER capabilities, and meet or exceed associated performance requirements. To accommodate Space Station, and the Shuttle Launch Support System (SLSS), the RER Upgrade must also support SN signal modes. This capability can serve as a ground-based SN backup capability. Support of both SN and GN modes by a GN ground terminal affords the option to user missions to reduce transponder power and weight by having only a SN mode capability.

SN modes use suppressed carrier modulation, as well as PN spread spectrum signalling. Spread spectrum operation also provides benefits by allowing NASA to mitigate RF interference into, as well as from NASA satcom links --- a key concern as the RF spectrum becomes increasingly crowded.

Receiver. The receiver must perform the following basic functions: Telemetry Data Demodulation, Polarization Combining, Baseband Telemetry Data Processing, Autotrack, Range Tracking, and Doppler Tracking.

Telemetry data demodulation is required for both SN and GN signals, involving both residual and suppressed carrier formats. Moreover, in the GN mode, up to 3 subcarriers may need to be supported (e.g., engine data from Shuttle's three main engines). The following signal modulations are possible, involving symbol rates from 100 bps to 5-10 Msps.

- Carrier PM Modulated by Data, Range Tones and PSK Subcarriers (0-3)
- Carrier PM Modulated by Data, CW Range Subcarrier (Shuttle)
- Carrier FM Modulated by PSK-Modulated Subcarrier (Shuttle Engine Data)
- Carrier FM Modulated by TV/Analog Data
- Carrier FM Modulated by Digital Data (FSK)
- BPSK, QPSK, PN/BPSK, SQPN.

Polarization combining of orthogonal polarized signals has been an important and necessary feature of the current GN MFRs. The extent that polarization is needed varies from spacecraft to spacecraft and even pass to pass. Polarization combining seems to be particularly critical for high elevation passes.

The antenna system provides X-axis (δx) and Y-axis (δy) error signals, each in two orthogonal polarizations, to the receiver as part of the autotrack function. Analogous to the processing of the two orthogonal sum channels (Σ_A and Σ_B), the receiver must: (1) optimally combine the orthogonal error signals for each axis, (2) amplitude detect the combined signal, and (3) provide the recovered X and Y error signals to the antenna tracking system.

Ranging. The existing GN ranging function is implemented in separate equipment from that of the exciter and receiver. For the RER Upgrade, an important goal is to integrate the ranging function into the receiver and exciter. This approach reduces and simplifies equipment, and thereby, reduces operations and maintenance costs. GN ranging is a tone ranging system, in which transit time is determined by comparing the phases of transit and receive tones. Tones from 500 KHz to 10 Hz are used, in conjunction with an ambiguity resolving PN code for range ambiguities of 644,000 Km. An accuracy of 1 meter (1σ) is required at a C/N_0 of 50 dB-Hz.

Transmitter. The transmitter must perform the following basic functions: Command Data, Modulation, Range Tone Generation, Test Signal Generation, Frequency Upconversion (to S-band), Range Zero Set, and Command Echo Verification.

For the uplink command signal, the modulation is required to provide for (1) GN Mode: a PM signal with either data/range tones directly on the carrier or on a subcarrier, and (2) SN Mode: PSK signal with/without PN spreading. To enhance overall operability and maintainability, the transmitter must also be capable to operate as a test signal generator for the receiver, which requires the generation of all the input signal modes and formats noted earlier for the receiver.

In summary the RER Upgrade must not only meet current GN and SN requirements, but also provide this capability in a fashion that reduces costs and enhances operations. Also critical is that the Upgrade be compliant with AGNS, by facilitating high-levels of automation and standard interfaces.

UPGRADE RER ARCHITECTURE

In response to the above needs, an upgrade architecture has been developed and is shown in Exhibit 1. Both uplink command and downlink telemetry signal processing are implemented in equipment chains or strings. Key features to note are:

- A processing "chain" consists of dedicated equipments that handle all processing between baseband and RF, thereby effectively eliminating all switching in operational signal paths
- Levels of reliability are achieved through redundant processing chains, which can operate in various "stand-by" modes, depending on outage/contingency requirements
- Additional receive chain reliability is achieved by configuring two or more receivers within each receive chain at the multicoupler output.

The upgrade architecture is modular, flexible, and expandable --- critical characteristics to meet current and future growth requirements. Accordingly, each station can tailor the specific number of chains and redundant units within chains to suit their individual needs and service support requirements. For example, Shuttle support, which requires high reliability, may be achieved with additional processing chains and/or additional receiver units within a receive telemetry chain.

This so-called "string" architecture has also been adopted by NASA's STGT (Second TDRSS Ground Terminal) in response to lessons learned from WSGT, which uses a pooled equipment approach to architecture. The GN Upgrade architectural approach is greatly facilitated by advanced flexible receiver/transmitter units (described below) which are compact and relatively low cost. Today's rack of equipment for a single receiver or transmitter can be reduced to a single chassis or drawer within a rack.

In another related effort, all telemetry baseband processing is being performed within a single PC, further enhancing the "string" architecture approach. Based on these efforts and advances in signal processing, Exhibit 2 depicts the corresponding hardware configuration that supports the advanced

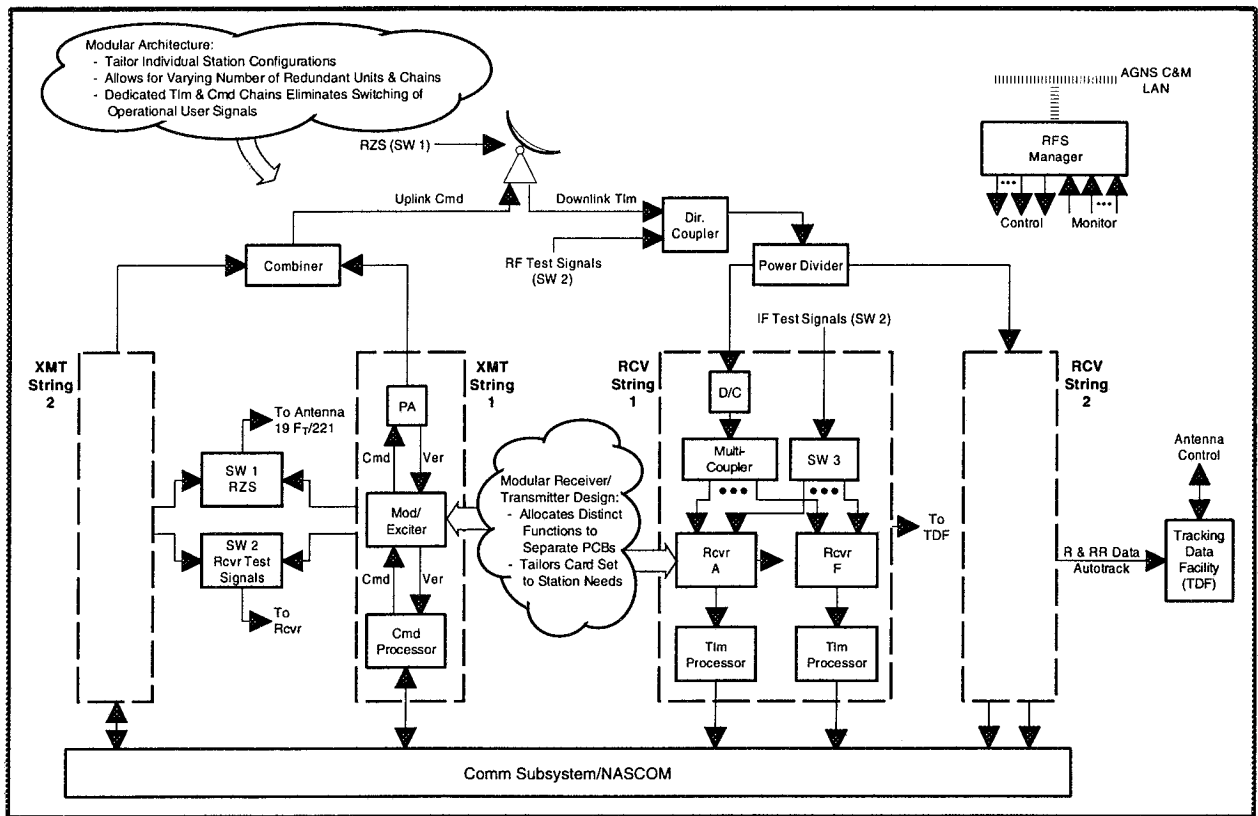

07/11/94 PAPER_94TB1101

Exhibit 1: RER Upgrade Architecture

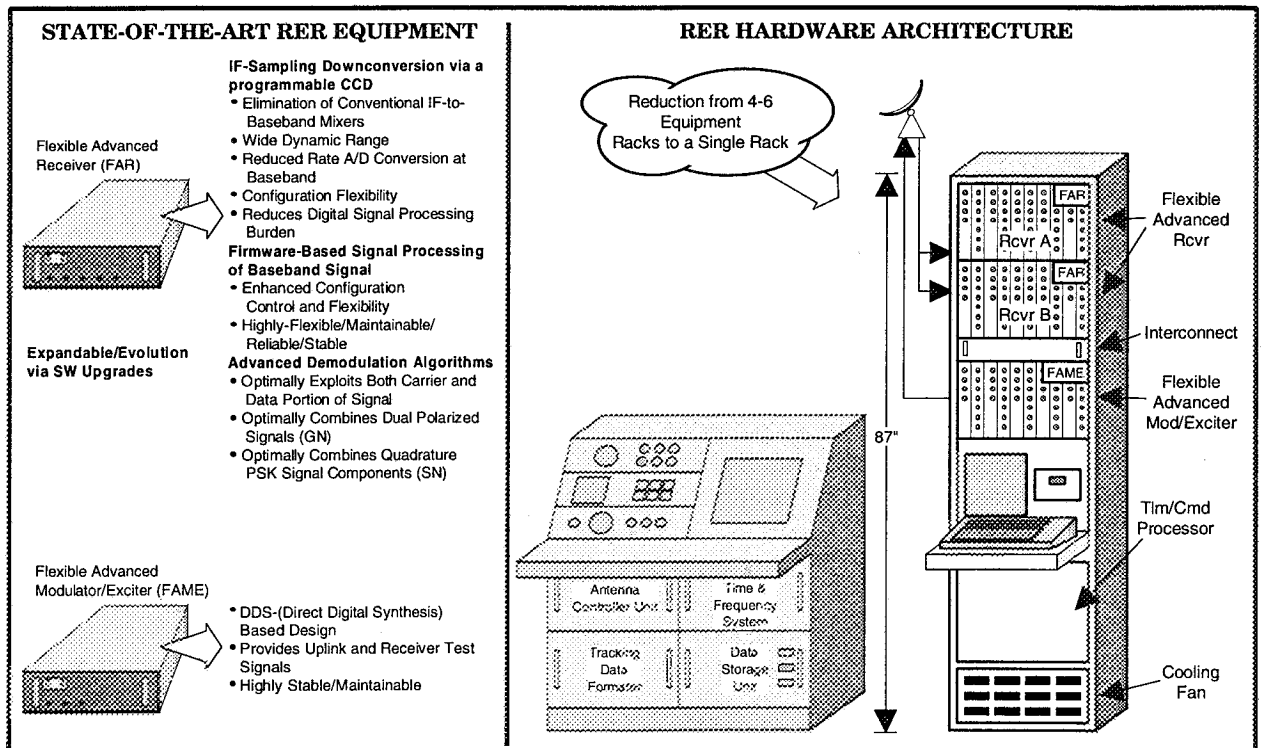

07/11/94 PAPER_94TB1102

Exhibit 2: Advanced Architecture Hardware Description

Station Architecture. In effect, one command chain and one telemetry chain (with two receiver units) can be reduced to a single rack -- a reduction of more than 4 to 1.

RECEIVER ARCHITECTURE

A receiver design has been developed to meet the requirements and design goals noted earlier. The receiver, referred to as the Flexible Advanced Receiver (FAR), is an evolution of the advanced CCD/Software receiver technology developed under sponsorship of NASA HQ/Code O (Advanced Systems) and GSFC/Code 531. The FAR is a state-of-the-art (SOA) system employing novel architecture and advanced technology to provide extensive capability in a compact package. Moreover, as the name indicates, much of the receiver processing is performed in software which promotes the desired flexibility and maintainability.

The receiver is comprised of two fundamental processing blocks that maximize the use of SOA analog processing, employing programmable CCD's (Charged Coupled Devices) followed by firmware processing, using multiple Motorola DSP96002 DSP chips. The CCD is essentially an analog tapped delay line with programmable tap weights. The FAR CCD is the 2-ATC chip which is the latest of Lincoln Lab's programmable CCD chips. The 2-ATC chip is specifically tailored for NASA/SN applications, and was developed under sponsorship of NASA HQ/Code O (Advanced Systems) and GSFC/Code 531. The resulting architecture is extremely powerful, yet flexible to support a wide range of signal formats and conditions through software changes only.

Exhibit 3 presents the FAR receiver architecture, showing support to all six input channels required to handle polarization combining and autotrack processing. As shown, there are four basic modules whose functionality is highlighted below:

- Common IF Module
 - Tunes 1st IF to a Common Fixed IF (e.g., 140 MHz)
 - Performs Noncoherent AGC on

Wideband Input Signal

- Advanced Diversity Demod (ADD)
 - Optimally Combines GN Orthogonal Polarized Sum Channels (Σ_A and Σ_B)
 - Optimally Processes SN PSK Quadrature Components (I and Q)
 - Demodulates Carrier/Subcarriers to Provide Telemetry Data & Range Tones
- Autotrack IF Processor (AIP)
 - Provides Digital Difference Channel Samples to ASP
- Autotrack Signal Processor (ASP)
 - Combines Dual Polarized Channels
 - Provides Amplitudes to Antenna Subsystem for Antenna Pointing.

Preliminary design analysis indicates that the FAR receiver, in its full capability, will consist of 15 printed circuit boards or cards. Noteworthy is that specific functionality is assigned to distinct cards, so that a station needing less capability can simply remove corresponding cards and save costs. For example, a user not requiring autotrack can reduce the card set by five. The card set is comprised of a combination of COTS (Commercial-off-the-shelf) and custom cards.

The heart of the FAR is the Advanced Diversity Demod (ADD) which provides the powerful signal processing capability. The ADD high-level architecture is shown in Exhibit 4, which depicts the analog front-end followed by DSP firmware processing.

The CCD card receives the IF sum channels (Σ_A and Σ_B) from the Common IF module. The input IF is 140 MHz, and is downconverted to a third IF through a novel scheme using a Track and Hold Amplifier (THA). The THA, whose sample rate is controlled using a NCO provides an aliased signal component at a lower IF which is extracted by the anti-aliasing low-pass filter.

The lower IF is then IF-sampled by the CCD to provide an analog sampled baseband output signal. The signal consists of alternate quadrature I and Q samples. Relative to conventional mixing to baseband, IF sampling eliminates the "sin/cos" mixers, and provides all the information in a single path, with substantially reduced complexity. Moreover, by appropriately adjusting the CCD programmable tap weights, the CCD performs as a

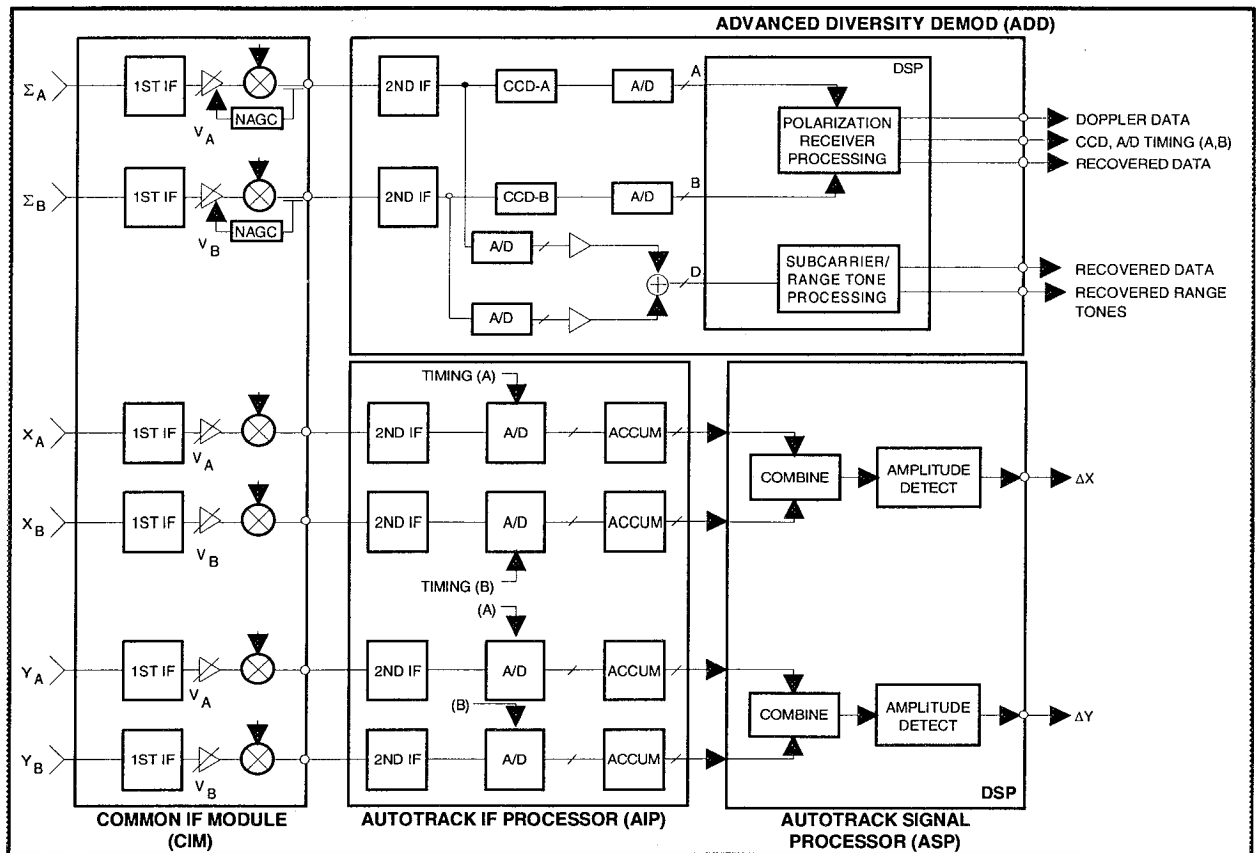

7/12/94 PAPER_94/TB5258

Exhibit 3: Advanced Receiver Architecture

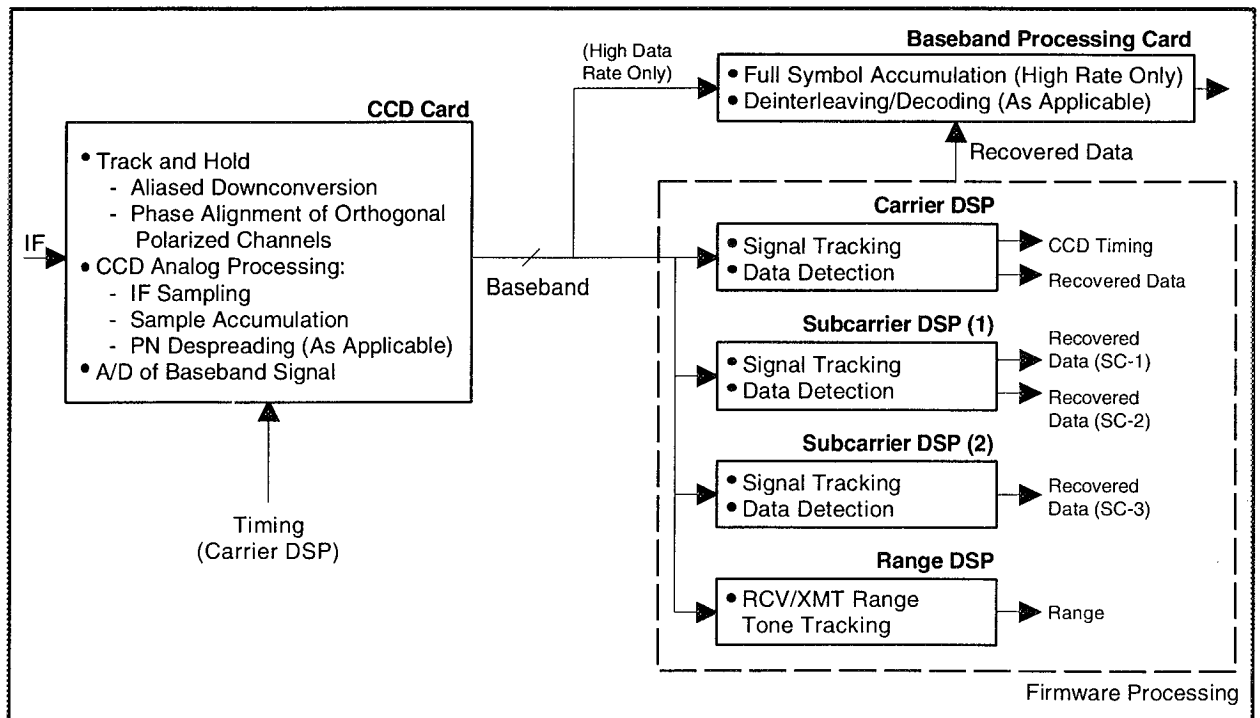

07/11/94 PAPER_94/TB1103

Exhibit 4: Advanced Diversity Demod (ADD) Architecture

matched filter in three ways: (1) matching to the alternating {1,-1} of the "peaks" of the IF CW, (2) data matched filtering by accumulating samples from the same symbol within a CCD length, and (3) PN code despreading with a local PN code (for spread spectrum signalling).

The CCD weighted-sample accumulation is a critical aspect of this unique architecture in that it greatly reduces the processing requirements imposed on the subsequent digital/firmware processing. This, coupled with the wide dynamic range inherent in analog processing, provide significant benefits over pure digital receivers. Furthermore, the 2-ATC chip provides two distinct CCDs on a single chip (ideally suited for two orthogonal polarized signals or quadrature QPSK components) offering the potential for compact, low power applications.

The analog CCD output is A/D converted and provided to the digital cards for signal processing-- all in μ P firmware. There are four DSP cards to handle carrier, subcarrier, and range processing. All DSP cards are identical, having the same hardware architecture. Key features are listed below:

- Four 32-Bit DSP96002 Floating Point DSPs
 - Arranged in a Fully Interconnected Modified Hypercube Architecture
 - Operating at 20 MIPS each with Full Resource Redundancy
- Design Repetition at Each Processor Standardizes Programmer's Interface
- Serial Communications
 - 4 LAN and up to 8 Serial Ports
 - Eurobus Digital Interface Facilitates System Expansion through Memory-Mapped Add-On Cards.

Receiver signal processing uses the receiver architecture discussed above to perform the following basic functions: (1) Signal Tracking (carrier, symbol, PN code), (2) Polarization Combining, (3) Subcarrier Processing, and (4) Range Processing. All signal processing performed to support signal tracking is performed in DSP firmware that, in turn, adjusts appropriate NCOs to effect tracking. An "integrated" receiver tracking approach is used

in which, for example, the symbol synchronizer is used for data-directed carrier tracking operations. This improves overall SNR performance relative to conventional Costas Loop operation for PSK signalling. For the FAR, it is also applied in a novel way to optimally demodulate PM modulated signals.

TRANSMITTER ARCHITECTURE

To complement the receiver performance upgrades, and support the overall RER Upgrade architecture, a new, flexible transmitter design has been developed. The new transmitter architecture, described in Exhibit 5, is referred to as the Flexible Advanced Modulator/Exciter (FAME). It makes use of emerging technologies such as Direct Digital Synthesis (DDS) and embedded micro-controllers that allow for effective automation.

The FAME architecture is divided into five functional blocks: (1) Baseband Modulator, (2) Upconverter, (3) Verification Receiver, (4) Synthesizer, and (5) FAME Controller.

The Baseband Modulator stands to benefit significantly from DDS technology. Exhibit 6 is the high-level Baseband Modulator architecture, and shows the extensive use of highly integrated ASICs now available for DDS, Forward Error Correction (FEC), and PN Coding. Use of ASICs promises dramatic size reductions as well as enhanced automatic control capability. To make the transmitter as flexible as possible and make efficient use of the emerging technology, eight MUXs allow for the routing of digitally represented waveforms in a variety of paths such that it can assemble a diverse set of signal structures. The DDS ASICs themselves offer excellent phase and frequency resolution with minimal or no calibration.

SUMMARY

An advanced station architecture has been designed that promises to substantially reduce equipment and operational complexity. The architecture is based on new, flexible receiver and transmitter units that uniquely leverage the state-of-the-art in both analog (e.g., CCDs) and digital signal processing (DSPs) technologies. Noteworthy is that the capabilities of this equipment can simply evolve and expand through software changes.

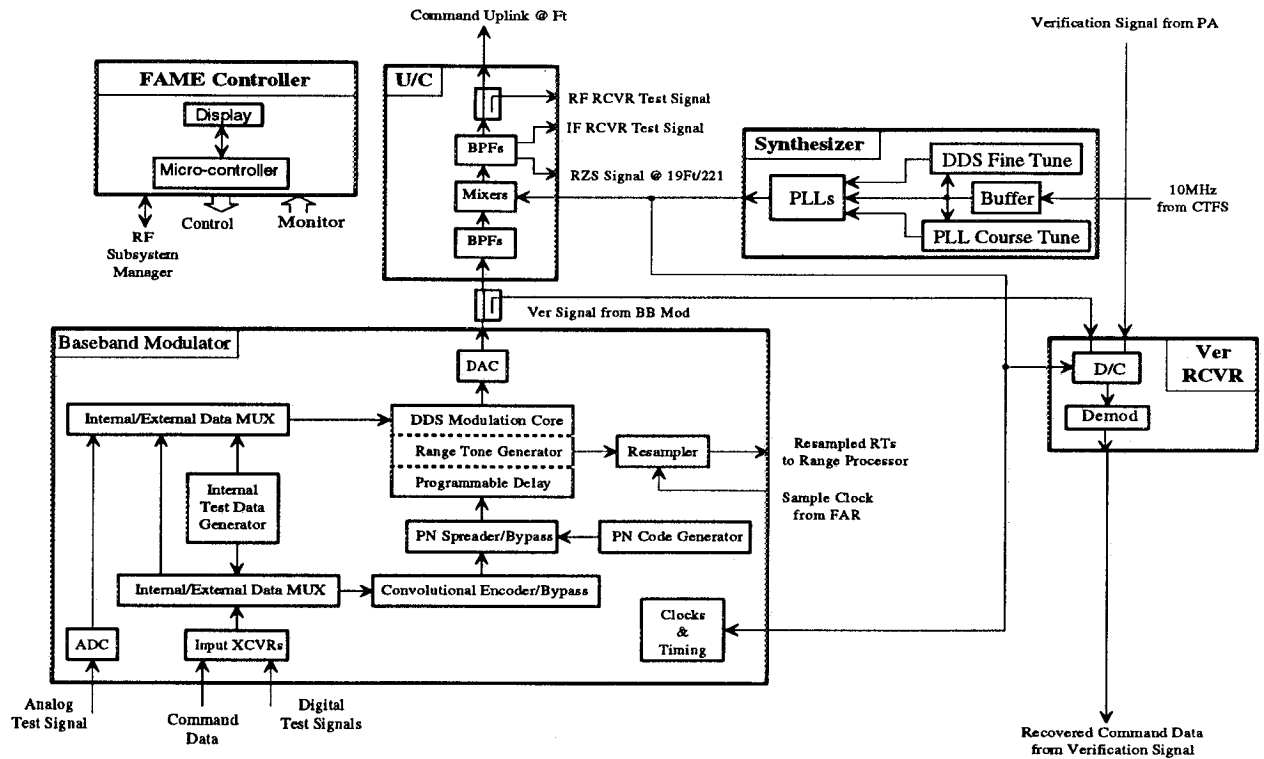

Exhibit 5: Flexible Advanced Modulator/Exciter Architecture

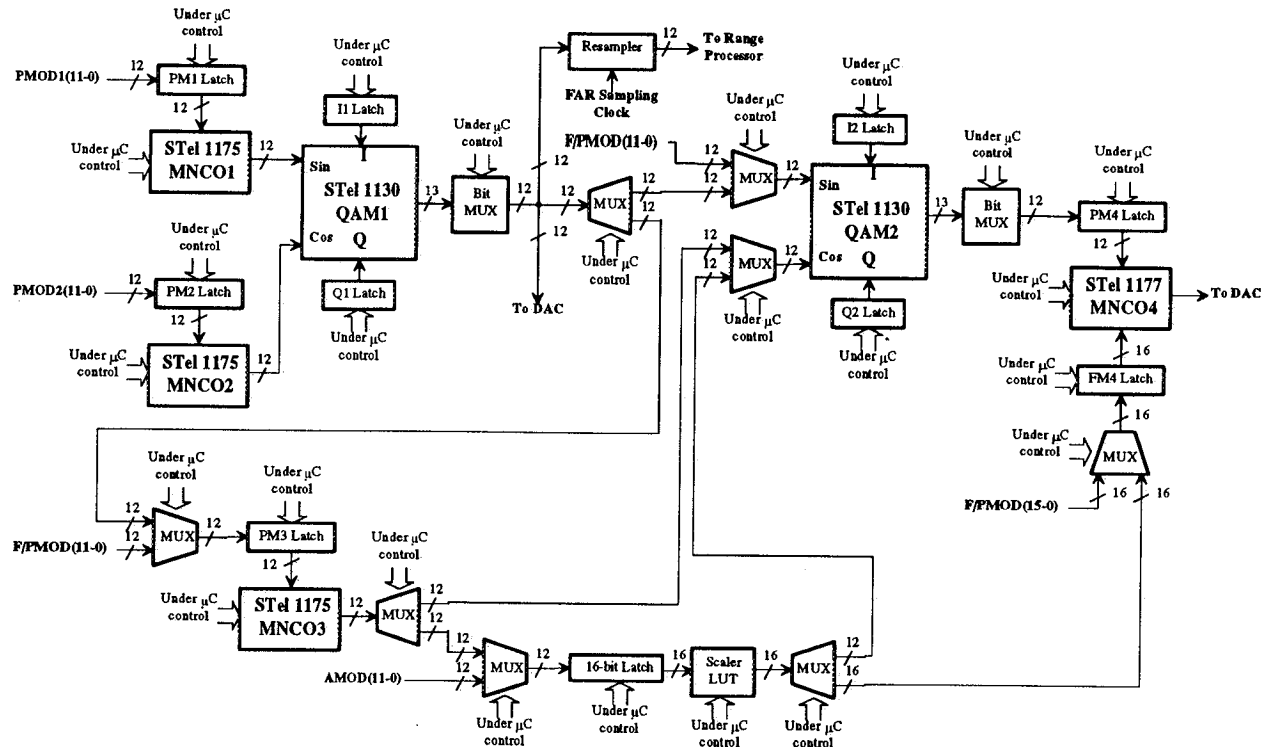

Exhibit 6: Baseband Modulator Design

Systems Development

2. Development Tools

Page 897

SD.2.a	Automating Testbed Documentation and Database Access Using World Wide Web (WWW) Tools <i>Charles Ames, Brent Auernheimer, Young H. Lee</i>	899-904 -26
SD.2.b *	Towards an Integral Computer Environment Supporting System Operations Analysis and Conceptual Design <i>E. Barro, A. Del Bufalo, F. Rossi</i>	905-913 -27
SD.2.c	SEQ_POINTER: Next Generation, Planetary Spacecraft Remote Sensing Science Observation Design Tool <i>Jeffrey S. Boyer</i>	915-922 -28
SD.2.d *	Knowledge-Based Critiquing of Graphical User Interfaces With CHIMES <i>Jianping Jiang, Elizabeth D. Murphy, Leslie E. Carter, Walter F. Truszkowski</i>	923-928 -29
SD.2.e	SEQ_REVIEW: A Tool for Reviewing and Checking Spacecraft Sequences <i>Pierre F. Maldague, Mekki El-Boushi, Thomas J. Starbird, Steven J. Zawacki</i>	929-936 -30
SD.2.f	Simplifying Operations With an Uplink/Downlink Integration Toolkit <i>Susan Murphy, Kevin Miller, Ana Maria Guerrero, Chester Joe, John Louie, Christine Aguilera</i>	937-943 -31
SD.2.g	ELISA, A Demonstrator Environment for Information Systems Architecture Design <i>Chantal Panem</i>	945-952 -32
SD.2.h	Software Interface Verifier <i>Tomas J. Soderstrom, Laura A. Krall, Sharon A. Hope, Brian S. Zupke</i>	953-960 -33

* Presented in Poster Session