

32014
p. 8

AN OPPORTUNITY ANALYSIS SYSTEM FOR SPACE SURVEILLANCE EXPERIMENTS WITH THE MSX

Ramaswamy Sridharan, Gary Duff, Tony Hayes, and Andy Wiseman
MIT Lincoln Laboratory

Abstract - The Mid-Course Space Experiment consists of a set of payloads on a satellite being designed and built under the sponsorship of Ballistic Missile Defense Office. The MSX satellite will conduct a series of measurements on phenomenology of backgrounds, missile targets, plumes and resident space objects (RSOs); and will engage in functional demonstrations in support of detection, acquisition and tracking for ballistic missile defense and space-based space surveillance missions. A complex satellite like the MSX has several constraints imposed on its operation by the sensors, the supporting instrumentation, power resources, data recording capability, communications and the environment in which all these operate. This paper describes the implementation of an opportunity and feasibility analysis system, developed at Lincoln Laboratory, Massachusetts Institute of Technology, specifically to support the experiments of the Principal Investigator for space-based surveillance.

1.0 INTRODUCTION

The Mid-Course Space Experiment consists of a set of payloads on a satellite being designed and built under the sponsorship of Ballistic Missile Defense Office (formerly, Strategic Defense Initiative Office) of the Department of Defense. The major instruments are :

1. A set of sensors being built by Utah State University, called SPIRIT 3, covering the spectral range from 4.2μ to 20μ in the long wave infra-red band.
2. A set of sensors operating in the ultraviolet and visible wavelengths ($0.1\mu - 0.9\mu$), called UVISI, being built by Johns Hopkins University's Applied Physics Laboratory.
3. A broad-band visible wavelength sensor ($0.4\mu - 0.9\mu$), called SBV, being designed and built by Lincoln Laboratory, Massachusetts Institute of Technology.
4. A set of sensors for monitoring and measuring contamination of the mirrors and the space around the MSX.

The satellite bus is being built by JHU/APL who is also acting as the integrator for all the sensors and associated systems. The MSX satellite, shown in Fig. 1, is due for launch in late 94 from the Vandenberg launch complex. It will be in a nearly sun-synchronous orbit with an orbital inclination of 99° and an orbital period of 103 minutes.

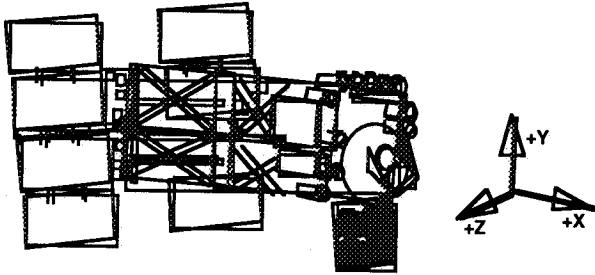

Fig. 1. MSX spacecraft

The MSX satellite will conduct a series of measurements on phenomenology of backgrounds, missile targets, plumes and resident space objects (RSOs); and will also conduct functional demonstrations in support of detection, acquisition and tracking for ballistic missile defense and space-based space surveillance missions. Eight Principal Investigators are associated with the MSX project. The area of interest in this paper is the surveillance of resident space objects from a space-based platform. The Principal Investigator for Space

Surveillance is located at Lincoln Laboratory, Massachusetts Institute of Technology. The SBV is the major instrument being used in space-based satellite surveillance experiments. The command and control center for the SBV, called SPOCC, is also at Lincoln Laboratory. All space surveillance experiments are conducted by the Surveillance PI using the resources of SPOCC.

The conduct of experiments with the MSX has a long planning cycle, similar to NASA scientific satellites. A key aspect of experiment planning is the analysis of the opportunities available for conducting any experiment, taking into account geometric and spacecraft constraints. A software system has been built in SPOCC to support the opportunity analysis for space-based surveillance experiments. We describe, in this paper, the process of computing the opportunities for and analyzing the feasibility of space-based surveillance experiments with the MSX and illustrate it with an example.

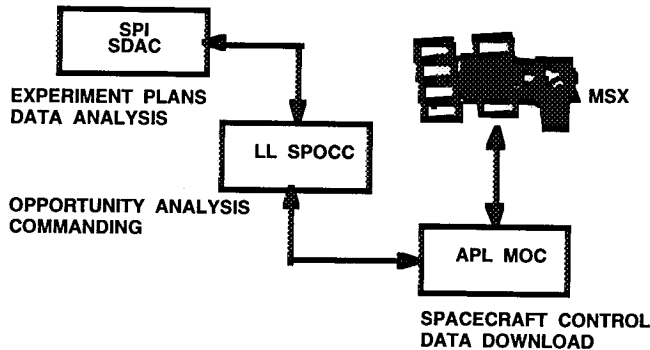

Fig. 2 : Data Flow for Surveillance Experiments

The SBV Processing, Operations and Control Center, located at Lincoln Laboratory, Massachusetts Institute of Technology, generates the necessary commanding for the MSX and its sensors for all space-based space surveillance experiments designed by the PI for Surveillance. SPOCC also converts and calibrates the returned science data from the SBV before turning them over to the SPI's Surveillance Data Analysis Center. The data flow is illustrated in Fig. 2. JHU/APL's Mission Operations Center is in overall charge of the spacecraft.

2.0. MSX AND ITS INSTRUMENTS

It is necessary to have a working knowledge of the MSX spacecraft, its sensors and their interaction to understand the functioning of the Opportunity Analysis System.

Figure 1 shows the body reference axes defined for the MSX spacecraft. All major sensors on the MSX have their fields of view substantially co-aligned along the +X-axis.

The MSX will be launched into a near-sun-synchronous, 99 deg. inclination orbit with an orbital period of 103 minutes. The satellite will have shadow periods as long as a third of the orbit due to the initial value of the right ascension of the ascending node. It carries a set of Nickel-Hydrogen batteries for powering the spacecraft operations during eclipse. The batteries are recharged by the solar panels.

The MSX carries two redundant tape recorders for high bandwidth data recording. The tape recorders are operated singly (or in parallel for critical data). Each unit is capable of recording 36 minutes of data at 25 Mb/s or 180 minutes of data at 5 Mb/s.

The SPIRIT 3 infrared sensor has a dewar containing solid hydrogen to cool the focal planes to 10⁰ K. The lifetime of the sensor is critically affected by the rate of dissipation of the Hydrogen. This sensor writes out its data almost entirely to the tape recorder. There is a set of ultra-violet and visible wavelength imagers and spectrometers on board, collectively called the UVISI. These instruments also use the tape recorder for storage of experiment data.

The SBV is the third major sensor on board the MSX. This sensor is comprised of a 6-inch aperture off-axis rejection telescope, a camera with 4 CCD chips with a total field-of-view of ~6⁰ x 1.4⁰, a Signal Processor for data compression and an Experiment Controller. The Experiment Controller controls SBV operations and has a large data buffer to store science data processed by the Signal Processor. Raw science data can be written out to the tape recorder.

The MSX supplies power, data handling, telemetry, commanding and pointing capability for all the sensors on board. Expected pointing accuracy is of the order of 0.1° on board around all axes. The attitude processor data can be further processed in the ground-based Attitude Processing Center to yield a pointing/attitude knowledge of a few arcseconds.

The MSX weighs ~6000 lbs. on the ground and is due to be launched on a Delta 2 launch system in Nov. 94. The launch will be from the Vandenberg Air Force Station.

3.0. SPOCC SUPPORT OF SURVEILLANCE EXPERIMENTS

SPOCC, as mentioned earlier, is the mission planning node for all experiments of the Principal Investigator for Surveillance.

The major tasks of the mission planning system in SPOCC are:

- 1) to permit a study of the opportunities available for an experiment; and
- 2) to generate the necessary commands to the sensors and the spacecraft to execute the experiment.

This report concentrates on the opportunity analysis. The major question answered by opportunity analysis system is:

When can an experiment be conducted?

The answer to this seemingly simple question is complicated by the following requirements:

1. Opportunities have to be computed for a month, six weeks before the start of the month, due to the long planning cycle for the MSX.
2. A feasible opportunity implies that an experiment, as defined, can be conducted within the available time and without violating constraints on the spacecraft or the sensors.
3. Further, the spacecraft resources consumed (both renewable and non-renewable) by the experiment must be within limits allocated to the experiment.

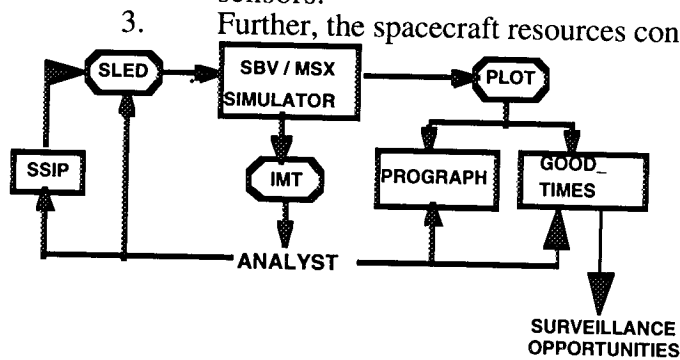

SLED : SBV LANGUAGE FOR EXPERIMENT DESIGN
 IMT : INSTANTIATED MISSION TIMELINE
 SSIP : SPACE SURV. INTERFACE PROCESSOR

Fig. 3: Opportunity Analysis Software System

A software system has been built in SPOCC to conduct opportunity analysis for surveillance experiments. Figure 3 captures the essential components of the System.

This system is invoked by a file of commands in a high level interface language called Surveillance Language for Experiment Design (Ref. 1). The SLED code can be written by a user, which is the predominant mode for most experiments involving the collection of data on a single resident space object (RSO). SLED code can also be

generated automatically by the Space Surveillance Interface Processor (SSIP), which is the mode for multi-RSO experiments and for experiments which have to be conducted with short notice (called Quick Reaction Events).

The components of the Opportunity Analysis System are described below.

3.1. SLED

The Surveillance (or SBV) Language for Experiment Design is a structured high-level language for describing space-based surveillance experiments with the SBV; and to a limited extent, with the SPIRIT 3 and the UVISI sensors. Principal characteristics of SLED are:

1. The language has a precise syntactic and logical structure.
2. The language permits description of a space surveillance experiment independent of detailed timing information.
3. The syntactic and logical structure is expandable to adapt to new requirements.

The fundamental requirement in the design of the SLED is to free the experimenter from the details of timing and control of the MSX and instead let him/her concentrate on the objectives and the logical design of the experiment.

3.2. The Simulator

The Simulator is the heart of the Opportunity Analysis System in SPOCC.

The Simulator parses and compiles the SLED code into a detailed event timeline which models the temporal flow of the experiment as a set of timed events for the sensors and the spacecraft. Each event implies a state change for the MSX and/or its instruments. The cost of each event is also accumulated by the Simulator. A block diagram of the Simulator functions with inputs and outputs is shown in Fig. 4.

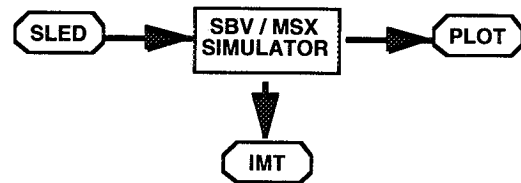

3.2.1. The Parser

All SLED code is parsed by the front end of the Simulator. The functions of the Parser are :

1. Check the SLED code for syntactic and logical consistency.
2. Check the implied modes of operation of the sensors for logical consistency.
3. Create ordered tables of the modes of operation of the sensors, and where applicable, their components.
4. Create ordered tables of the mode of operations of the MSX.

PARSING AND ERROR CHECKING
 CONTROLLING SENSORS AND S/C
 MODELLING GEOMETRICAL VARIABLES
 MODELLING RESOURCE COSTS

Fig. 4 : Functions of the Simulator

The tables built by the Parser are used by the entire Mission Planning System.

3.2.2. Spacecraft and Sensor Modelling

The Simulator has to create all the necessary events to render the MSX ready to collect data – including all turn-on/off of components and the attitude maneuvers necessary to re-orient the satellite before, during and after the experiment. The Simulator also creates events for commanding the sensors to collect, process and store the experiment data. Further, the Simulator concatenates all these events into an ordered timed set for further processing by the rest of the mission planning system.

3.2.3. Geometrical Modelling

The instruments on the MSX, and the MSX itself, impose several geometrical constraints on the pointing and orientation of the spacecraft. These constraints are divided into hard (potential

for damage) and soft (high resource usage). Significant constraints are summarized below.

Control of cryogen depletion on the SPIRIT 3 instrument is required to prolong its useful life. Hence the thermal input into the telescope axis from the sun and the earth must be kept low. This results in the following pointing constraints (see Fig. 1 for body reference axes):

- 1) The X-axis (which is the common telescope axis) should be kept away ($> 30^\circ$) from the sun direction (hard) and $> 63^\circ$ from the nadir (hard).
- 2) The +Y-axis, which defines the open or exposed side of the dewar containing the cryogen, should be kept $> 90^\circ$ away from the sun (soft).
- 3) The -Y-axis which defines the convex side of the SPIRIT 3 sunshade, should be kept $< 90^\circ$ from the nadir (soft).

Other major pointing constraints are :

- 1) The UVISI sensors require that the +X-axis be not pointed near the sun (hard) or at the solar specular point on the earth (hard) when they are on.
- 2) The SBV telescope field of view cannot be pointed at the sun for more than 15 minutes (hard). The SBV should be pointed at least 25° away from the sun for good data (soft).
- 3) The -X axis of the spacecraft cannot be pointed at the sun directly for fear of heating the battery (soft).

The Simulator models all the angles relevant to these geometrical constraints during a data collection. The precise values for the constraints are yet to be refined. The MOCARH, referred to earlier, will be the formal document for operational constraints.

The Simulator also propagates the orbit of the MSX and of any RSOs requested. Geometrical visibility of the RSOs and solar illumination of both the RSOs and the MSX are computed. Further various relevant phase and aspect angles are calculated. Finally, visibility from a set of ground-based downlink contact stations is also computed.

3.2.4. Resource Usage Constraints

The Simulator has a detailed model for the power usage on board and the power generated by the solar panels. Knowing the initial state of the battery, the depth of discharge is computed.

The tape recorder on the MSX and the data memory in the SBV are finite resources for recording science data. The Simulator monitors their usage and either terminates the experiment, in the case of the tape recorder, or requires a downlink contact, in the case of the SBV memory, when no more data can be written out.

The SPIRIT 3 sensor has a finite quantity (~900 liters) of solid hydrogen for cooling its focal planes. A cryogen depletion model has been developed by the instrument manufacturers that predicts the quantity of hydrogen lost as a function of thermal input from the earth and the sun. The Simulator uses this model to compute cryogen depletion while simulating an experiment.

The Simulator has a thermal model for key parts of the spacecraft, viz., the SPIRIT 3 baffle, the tape recorder heads and the battery. The baffle temperature affects the sensitivity of the SPIRIT 3 sensor significantly. The other components have been identified by their manufacturers as being prone to damage due to large temperature excursions. Hence, the temperature rise of these components during an experiment is estimated by the Simulator.

3.3. PROGRAPH Display System

The Simulator creates a number of output products. Of relevance to the Opportunity Analysis, however, is the following.

The Simulator writes out into a file all the resource usage and geometrical computations during the data collection event simulated. The PROGRAPH processor displays all of these variables in graphical form on a display. This enables the user to visualize the experiment cost and modify the SLED code appropriately to reduce the cost if necessary.

PROGRAPH is implemented with a commercial software package called PVWAVE. All variables are plotted on the against elapsed time during the data collection. The user can select any graph(s) to be expanded and displayed.

Visual analysis is aided by the following capabilities of PROGRAPH:

- 1) Display of a selected graph.
- 2) Display of selected variables in a graph.
- 3) Re-scaling of x and y axes on the graph (time elapsed during the data collection event is always the x-axis in the graph).

Generally, the analyst uses the X-axis constraints on the MSX and the power usage graphs as key indicators of the feasibility of an experiment.

3.4. GOOD_TIMES Process

The final step in the Opportunity Analysis process is to examine the values of the various parameters displayed by PROGRAPH and pick intervals of time when the experiment can be conducted while observing all constraints and not exceeding allocated costs.

The input data to PROGRAPH can be automatically analyzed by a process called GOOD_TIMES. Apart from the PROGRAPH data, a task file drives the GOOD_TIMES processor. The task file specifies the range of values permitted for each parameter. When invoked, the GOOD_TIMES process examines the entire PROGRAPH data and finds time intervals that satisfy all the constraints in the task file. The output is captured in a Surveillance Opportunities File which is the major data product produced by the Opportunity Analysis System and sent to the Mission Operations Center at JHU/APL.

4.0. AN EXAMPLE

A geosynchronous surveillance experiment will be taken as an example here. The requirement, as set by the Surveillance PI's experiment plan, is to survey any part of the geosynchronous belt for 3 consecutive hours using the SBV and its on-board signal processor. The geosynchronous belt is quite heavily populated with resident space objects. A space-based optical sensor like the SBV has the ability to efficiently survey and collect data on all the RSOs in the belt, unlike a ground-based sensor, which is restricted in coverage by geographic location and inhibited in its operation by daylight and clouds. Hence a geosynchronous surveillance experiment is key to demonstrating the utility of space-based surveillance.

In the present example, the search strategy chosen was to point at a location in right ascension in the geostationary belt and vary the declination in steps between $+3.5^\circ$ and -3.5° . Fig. 5 depicts the search strategy.

The MSX is due for launch in late '94. However, for the purpose of this study, the launch date was chosen to be Oct 93. Orbital elements were specified by the MSX

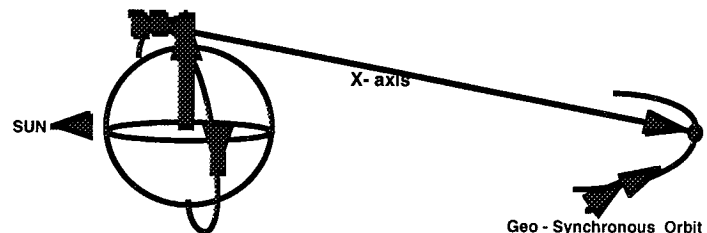

Fig. 5. Geosynchronous Search

Stare at fixed point in Geosynchronous Belt

program.

Two optional roll laws for the MSX are used in this example:

- 1) the $-Y$ axis is pointed as close as possible to the nadir ($-Y$ -TO-EARTH)
- and 2) the $-Y$ axis is pointed as close as possible to the sun ($-Y$ -TO-SUN).

Roll law refers to the rotation of the MSX about its common pointing or $+X$ - axis. The first roll law minimizes the thermal input into the SPIRIT 3 telescope from the earth because the convex side of the earth(sun)shade (its bottom) faces the earth all the time as the MSX orbits the earth. Thus the cryogen is conserved. The second roll law enables the solar panel axis (the Z -axis) to be as close to perpendicular to the sun as possible because the MSX orbit is near-polar and near-normal to the earth-sun line. Thus the solar panels can be rotated about the Z -axis for maximum solar illumination and power generation. These are the type of soft constraints that an analyst examines to assess the resource usage of the experiment. The effects of the roll laws on the cost of the experiment are illustrated below.

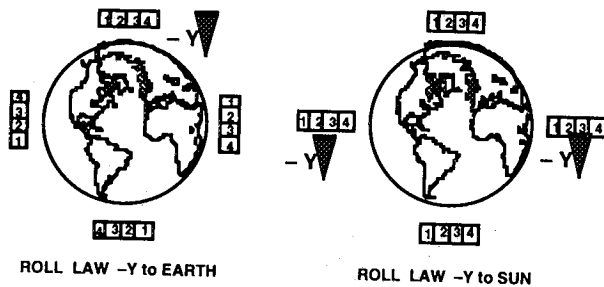

Fig. 6: Roll Laws and SBV Focal Planes

Fig. 6 shows the orientation of the SBV focal plane, which is extended along the Z -axis, under the two roll laws. The focal plane consists of 4 CCDs, each with 420×420 pixels, butted against each other. The individual field-of-view is $1.4^\circ \times 1.4^\circ$. The total FOV is $\sim 6.6^\circ \times 1.4^\circ$ because of distortion effects of the off-axis reimaging optical system. The figure shows that with the $-Y$ -to-earth roll law, the focal plane is rolled as

with the $-y$ - axis maintained pointing at earth center. Such an orientation reduces the thermal input from the earth into the SPIRIT 3 aperture ($+X$ - axis) thus helping to keep it cold. The focal plane, on the other hand, stays invariant in space under the $-Y$ - to -sun roll law. Such an orientation allows the solar panels to be rotated about the Z -axis for maximum power production, but at the price of greater thermal input from the sun into the $+X$ -axis with the consequence of higher cryogen depletion.

Figure 7 shows the estimated depth-of-discharge of the battery as a result of the experiment being conducted for 24 hours with the two roll-laws. There is a periodic component in battery depth of discharge that arises from the orbital period of the satellite - recall that the MSX is in earth shadow for part of the orbit. There is a secular component, clearly evident in the graph for the roll law " $-Y$ -TO-EARTH" that is due to the inadequate re-charging of the battery in the illuminated part of the orbit. A requirement is that the battery be not depleted by more than 40% routinely with 60% as an extreme limit. It is evident that the experiment has to be cut short at ~ 28000 seconds with the first roll law. However, when the " $-Y$ -TO-SUN" roll law is used, the solar panels can be rotated for maximum power production and hence the depth-of-discharge does not have a secular component. Therefore, the experiment can be continued indefinitely from a power perspective.

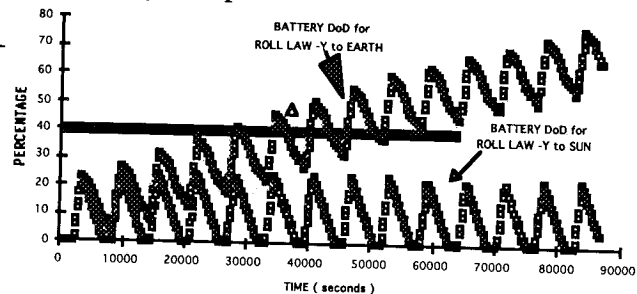

Fig. 7: Battery Depth of Discharge

The gain in power, and in the battery depth-of-discharge, however comes at a price. The temperature of the baffle of the SPIRIT 3 telescope (inside the sunshade shown in Fig. 1) is affected by the thermal input into the aperture; and, further, the cryogen depletion is related to the thermal input and the baffle temperature. Also, the baffle temperature directly affects the noise

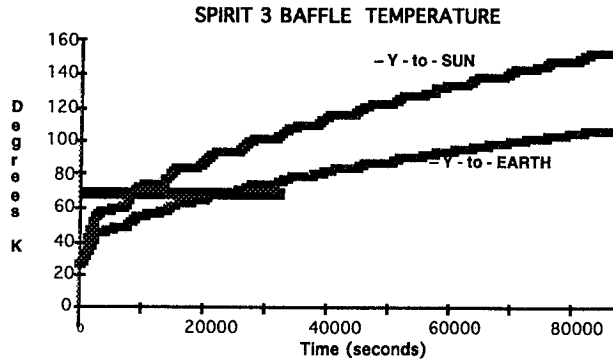

Fig. 8 : Baffle Temperature

input into, and hence the quality of, the data from the focal plane of the SPIRIT 3. Fig. 9 shows that, while conserving battery power, the roll law “-Y-TO-SUN” causes a more rapid rise of the baffle temperature, and consequently, battery power, the roll law “-Y-TO-SUN” causes a more rapid rise of the baffle temperature, and consequently, cryogen depletion. Also, the baffle cools very slowly and thus the data quality for any subsequent experiment using the SPIRIT 3 is degraded for a longer time than if the roll law “-Y-TO-EARTH” were used.

The orbit of the MSX is not quite sun-synchronous. It precesses with respect to the sun slowly. Hence, the power balance between the solar panels and the battery changes over a period of time. Figure 9 illustrates the effect of the time of instantiation of an experiment on the power balance. A 24 hour long geosynchronous experiment conducted in July 94 depletes the battery more rapidly than if it were conducted in Jan. 95. The difference is entirely due to the fact that the periods the MSX is in earth shadow are much shorter on the latter date.

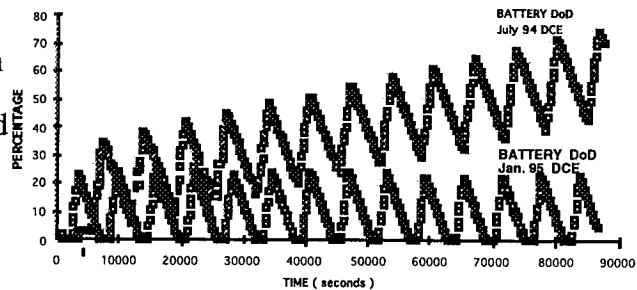

Fig. 9 : Effect of Time of Instantiation

5.0 SUMMARY

A successful Opportunity Analysis System has been developed in SPOCC to facilitate the scheduling of the Surveillance Principal Investigator’s experiments on the MSX. The system uses knowledge of relevant geometries and spacecraft and instruments constraints to model the cost of conducting an experiment. The system has been tested extensively and fully supports the long experiment planning process associated with the MSX.

BIBLIOGRAPHY

1. John D. Mill, et al: “The Midcourse Space Experiment: Introduction to the Spacecraft, Instruments and Scientific Objectives”, JSR (accepted for publication).
2. R. Sridharan, et al: “An Opportunity Analysis System for Space Surveillance Experiments with the MSX”, Technical Report No. 1011 (to be published).