

NASA Contractor Report CR - 195420

Mars Power System Concept Definition Study (Task Order No. 16)

Volume 2 - Appendices

Franklin D. Littman
Rockwell International Corporation
Rocketdyne Division
Canoga Park, California

December 1994

Prepared for
Lewis Research Center
Under Contract NAS3 25808

NASA
National Aeronautics and
Space Administration

(NASA-CR-195420-Vol-2) MARS POWER
SYSTEM CONCEPT DEFINITION STUDY.
VOLUME 2: APPENDICES Final Report
(Rockwell International Corp.)
276 p

N95-21953

Unclas

G3/44 0039170

FOREWORD

This report documents the work performed by Rockwell International's Rocketdyne Division on NASA Contract No. NAS3-25808 (Task Order No. 16) entitled "Mars Power System Definition Study." This work was performed for NASA's Lewis Research Center (LeRC). The NASA LeRC Task Order Contract Technical Manager was Mr. William A. Poley and the Specific Task Manager was Mr. Robert Cataldo. The Rocketdyne project engineer was Mr. James M. Shoji.

The report is divided into two volumes as follows:

- Volume 1 - Study Results
- Volume 2 - Appendices

The results of the power system characterization studies, operations studies, and technology evaluations are summarized in Volume 1. The appendices include complete, standalone technology development plans for each candidate power system that was investigated.

TABLE OF CONTENTS

LIST OF FIGURES	v
LIST OF TABLES	vi
NOMENCLATURE	vii
APPENDIX A - CBC DIPS TECHNOLOGY ROADMAP.....	A- 1
INTRODUCTION	A- 1
CONCEPT DESCRIPTION	A- 3
TECHNOLOGY ISSUES	A- 15
TECHNOLOGY ASSESSMENT.....	A- 15
GPHS MODULE STATE-OF-THE-ART	A- 16
HSU STATE-OF-THE-ART	A- 17
TAC ASSEMBLY STATE-OF-THE-ART.....	A- 19
RECUPERATOR STATE-OF-THE-ART	A- 20
RADIATOR STATE-OF-THE-ART.....	A- 21
INTERCONNECT DUCTING STATE-OF-THE-ART	A- 22
PP&C STATE-OF-THE-ART.....	A- 23
MAJOR DEVELOPMENT TASKS	A- 25
TASK 1. HEAT SOURCE UNIT HEAT EXCHANGER (HSUHX) DEVELOPMENT.....	A- 25
TASK 2. TAC DEVELOPMENT	A- 27
TASK 3. RECUPERATOR DEVELOPMENT	A- 28
TASK 4. RADIATOR/MANIFOLD ASSEMBLY DEVELOPMENT	A- 29
TASK 5. INTERCONNECT DUCTING DEVELOPMENT	A- 30
TASK 6. PP&C DEVELOPMENT.....	A- 31
TASK 7. INTEGRATED SYSTEM TEST UNIT (ISTU) DEVELOPMENT AND TEST	A- 31
TASK 8. QUALIFICATION PROGRAM TESTING.....	A- 33
TASK 9. FLIGHT UNIT (FU) SYSTEM PROGRAM.....	A- 36
DEVELOPMENT SCHEDULE.....	A- 37
REFERENCES.....	A- 39
APPENDIX B - PEM RFC TECHNOLOGY ROADMAP	B- 1
INTRODUCTION	B- 1
CONCEPT DESCRIPTION	B- 1
FUEL CELL DESCRIPTION	B- 3
ELECTROLYZER CELL STACK DESCRIPTION.....	B- 5
THERMAL MANAGEMENT SUBSYSTEM DESCRIPTION.....	B- 7
WATER MANAGEMENT SUBSYSTEM DESCRIPTION.....	B- 10
STORAGE TANK DESCRIPTION.....	B- 12
PP&C SUBSYSTEM DESCRIPTION.....	B- 13
TECHNOLOGY ISSUES	B- 14
ISSUE #1 - LIMITED LIFE AND RELIABILITY.....	B- 15
ISSUE #2 - MATERIAL COMPATIBILITY.....	B- 16
ISSUE #3 - TEMPERATURE AND MOISTURE CONTROL.....	B- 16
ISSUE #4 - OXYGEN IN FUEL CELL PRODUCT WATER	B- 17
ISSUE #5 - WATER IN ELECTROLYZER GASES	B- 17
ISSUE #6 - LARGE RADIATOR DUE TO LOW HEAT REJECTION TEMPERATURE	B- 18
ISSUE #7 - LONG DURATION SYSTEMS	B- 19
ISSUE #8 - REACTANT STORAGE SYSTEM MASS AND VOLUME	B- 20
ISSUE #9 - HIGH PRESSURE TANK SAFETY	B- 20
ISSUE#10 - REDUCED EFFICIENCY OF ELECTROLYSIS CELLS AT HIGHER PRESS....	B- 21
ISSUE #11 - HIGH WATER PURITY REQUIREMENT	B- 21

TABLE OF CONTENTS (CONTINUED)

TECHNOLOGY ASSESSMENT.....	B - 22
RFC SYSTEM STATE-OF-THE-ART.....	B - 23
FUEL CELL STATE-OF-THE-ART.....	B - 23
ELECTROLYSIS CELL STACK STATE-OF-THE-ART.....	B - 25
THERMAL MANAGEMENT SUBSYSTEM STATE-OF-THE-ART.....	B - 27
WATER MANAGEMENT SUBSYSTEM STATE-OF-THE-ART.....	B - 30
REACTANT STORAGE TANK STATE-OF-THE-ART.....	B - 31
PP&C SUBSYSTEM STATE-OF-THE-ART.....	B - 32
MAJOR DEVELOPMENT TASKS.....	B - 32
TASK 1. PEM FUEL CELL MODULE DEVELOPMENT.....	B - 33
TASK 2. PEM ELECTROLYSIS CELL MODULE DEVELOPMENT.....	B - 33
TASK 3. THERMAL MANAGEMENT SUBSYSTEM DEVELOPMENT.....	B - 34
TASK 4. WATER MANAGEMENT SUBSYSTEM DEVELOPMENT.....	B - 36
TASK 5. REACTANT STORAGE TANKS.....	B - 37
TASK 6. PP&C SUBSYSTEM DEVELOPMENT.....	B - 37
TASK 7. GROUND ENGINEERING SYSTEM (GES) TESTING.....	B - 38
TASK 8. QUALIFICATION PROGRAM TESTING.....	B - 40
TASK 9. FLIGHT UNIT (FU) SYSTEM PROGRAM.....	B - 43
DEVELOPMENT SCHEDULE.....	B - 43
REFERENCES.....	B - 46
APPENDIX C - NAS BATTERY TECHNOLOGY ROADMAP.....	C - 1
INTRODUCTION.....	C - 1
CONCEPT DESCRIPTION.....	C - 1
BATTERY SUBSYSTEM DESCRIPTION.....	C - 2
THERMAL MANAGEMENT SUBSYSTEM DESCRIPTION.....	C - 5
PP&C SUBSYSTEM DESCRIPTION.....	C - 7
TECHNOLOGY ISSUES.....	C - 8
TECHNOLOGY ASSESSMENT.....	C - 9
SYSTEM STATE-OF-THE-ART.....	C - 10
BATTERY SUBSYSTEM STATE-OF-THE-ART.....	C - 10
THERMAL MANAGEMENT SUBSYSTEM STATE-OF-THE-ART.....	C - 11
PP&C STATE-OF-THE-ART.....	C - 14
DEVELOPMENT PLANS.....	C - 14
TASK 1. BATTERY SUBSYSTEM DEVELOPMENT.....	C - 15
TASK 2. THERMAL MANAGEMENT SUBSYSTEM DEVELOPMENT.....	C - 15
TASK 3. PP&C SUBSYSTEM DEVELOPMENT.....	C - 17
TASK 4. GROUND ENGINEERING SYSTEM (GES) TESTING.....	C - 17
TASK 5. QUALIFICATION PROGRAM TESTING.....	C - 19
TASK 6. FLIGHT UNIT (FU) SYSTEM PROGRAM.....	C - 20
DEVELOPMENT SCHEDULE.....	C - 23
REFERENCES.....	C - 25
APPENDIX D - PV/RFC TECHNOLOGY ROADMAP.....	D - 1
INTRODUCTION.....	D - 1
CONCEPT DESCRIPTION.....	D - 1
PHOTOVOLTAIC ARRAY SUBSYSTEM DESCRIPTION.....	D - 3
RFC DESCRIPTION.....	D - 6
FUEL CELL DESCRIPTION.....	D - 7
ELECTROLYZER CELL STACK DESCRIPTION.....	D - 10
RFC THERMAL MANAGEMENT SUBSYSTEM DESCRIPTION.....	D - 12
RFC WATER MANAGEMENT SUBSYSTEM DESCRIPTION.....	D - 14

TABLE OF CONTENTS (CONTINUED)

RFC STORAGE TANK DESCRIPTION	D - 17
PP&C SUBSYSTEM DESCRIPTION.....	D - 19
TECHNOLOGY ISSUES	D - 19
TECHNOLOGY ASSESSMENT.....	D - 21
PV ARRAY STATE-OF-THE-ART	D - 22
RFC STATE-OF-THE-ART.....	D - 23
FUEL CELL STATE-OF-THE-ART.....	D - 24
ELECTROLYSIS CELL STACK STATE-OF-THE-ART	D - 26
RFC THERMAL MANAGEMENT SUBSYSTEM STATE-OF-THE-ART.....	D - 28
RFC WATER MANAGEMENT SUBSYSTEM STATE-OF-THE-ART.....	D - 31
RFC REACTANT STORAGE TANK STATE-OF-THE-ART	D - 32
PP&C SUBSYSTEM STATE-OF-THE-ART	D - 34
DEVELOPMENT PLANS.....	D - 34
TASK 1. PV ARRAY DEVELOPMENT	D - 34
TASK 1-1. SUBSCALE PV ARRAY DEVELOPMENT.....	D - 34
TASK 1-2. FULL SCALE PV ARRAY DEVELOPMENT	D - 35
TASK 2. PEM FUEL CELL MODULE DEVELOPMENT.....	D - 35
TASK 3. PEM ELECTROLYSIS CELL MODULE DEVELOPMENT	D - 35
TASK 4. THERMAL MANAGEMENT SUBSYSTEM DEVELOPMENT	D - 36
SUBTASK 4.1 HEAT PIPE DEMONSTRATION.....	D - 36
SUBTASK 4.2 RADIATOR ENHANCEMENT	D - 37
SUBTASK 4.3 HEAT PIPE INTEGRATION AND TESTING.....	D - 37
SUBTASK 4.4 RADIATOR MODULE DESIGN, ASSEMBLY, FABRICATION & TESTING	D - 37
SUBTASK 4.5 PRELIMINARY ACTIVE COMPONENT DEVELOPMENT.....	D - 37
SUBTASK 4.6 FINAL ACTIVE COMPONENT DESIGN.....	D - 38
SUBTASK 4.7 ACTIVE CONTROL SUBSYSTEM FABRICATION, ASSEMBLY & TESTING	D - 38
TASK 5. WATER MANAGEMENT SUBSYSTEM DEVELOPMENT	D - 38
SUBTASK 5.1 GAS DRYER DEVELOPMENT	D - 38
SUBTASK 5.2 GAS HUMIDIFER DEVELOPMENT	D - 39
TASK 6. REACTANT STORAGE TANKS	D - 39
TASK 7. PP&C SUBSYSTEM DEVELOPMENT	D - 39
SUBTASK 7.1 ELECTRICAL COMPONENTS	D - 40
SUBTASK 7.2 SOFTWARE	D - 40
TASK 8. GROUND ENGINEERING SYSTEM (GES) TESTING	D - 40
TASK 8.1 GES DESIGN.....	D - 40
TASK 8.2 GES PERFORMANCE TESTS	D - 41
TASK 8.3 GES LIFE TEST	D - 42
TASK 9. QUALIFICATION PROGRAM TESTING.....	D - 42
SUBTASK 9.1 QUALIFICATION PERFORMANCE TESTING	D - 43
SUBTASK 9.2 QUALIFICATION LIFE TESTING (OPTIONAL)	D - 45
TASK 10. FLIGHT UNIT (FU) SYSTEM PROGRAM.....	D - 45
SUBTASK 9.1 FLIGHT COMPONENT FABRICATION.....	D - 46
SUBTASK 9.2 FU ASSEMBLY, TEST, AND PAYLOAD INTEGRATION.....	D - 46
SUBTASK 9.3 FU LAUNCH SUPPORT	D - 46
DEVELOPMENT SCHEDULE.....	D - 46
REFERENCES.....	D - 49

TABLE OF CONTENTS (CONTINUED)

APPENDIX E - PV/NAS BATTERY TECHNOLOGY ROADMAP	E - 1
INTRODUCTION	E - 1
CONCEPT DESCRIPTION	E - 1
SOLAR SUBSYSTEM DESCRIPTION.....	E - 3
BATTERY SUBSYSTEM DESCRIPTION	E - 6
THERMAL MANAGEMENT SUBSYSTEM DESCRIPTION.....	E - 9
PP&C SUBSYSTEM DESCRIPTION.....	E - 11
SHUNT REGULATOR DESCRIPTION.....	E - 11
BOOST REGULATOR DESCRIPTION	E - 11
DOWN REGULATOR DESCRIPTION.....	E - 12
TECHNOLOGY ISSUES	E - 12
TECHNOLOGY ASSESSMENT.....	E - 14
SYSTEM STATE-OF-THE-ART	E - 15
PV ARRAY STATE-OF-THE-ART	E - 15
BATTERY SUBSYSTEM STATE-OF-THE-ART.....	E - 17
THERMAL MANAGEMENT SUBSYSTEM STATE-OF-THE-ART	E - 18
PP&C STATE-OF-THE-ART.....	E - 21
DEVELOPMENT PLANS	E - 21
TASK 1. PV ARRAY DEVELOPMENT	E - 22
TASK 1.1 SUBSCALE PV ARRAY DEVELOPMENT	E - 22
TASK 1.2 FULL SCALE PV ARRAY DEVELOPMENT	E - 22
TASK 2. BATTERY SUBSYSTEM DEVELOPMENT.....	E - 22
SUBTASK 2.1 PRELIMINARY BATTERY DEVELOPMENT	E - 22
SUBTASK 2.2 FINAL BATTERY MODULE DESIGN	E - 22
SUBTASK 2.3 BATTERY MODULE FABRICATION, ASSEMBLY, AND TESTING.....	E - 22
TASK 3. THERMAL MANAGEMENT SUBSYSTEM DEVELOPMENT	E - 22
SUBTASK 3.1 HEAT PIPE DEMONSTRATION.....	E - 23
SUBTASK 3.2 RADIATOR ENHANCEMENT	E - 23
SUBTASK 3.3 HEAT PIPE INTEGRATION AND TESTING.....	E - 24
SUBTASK 3.4 THERMAL MANAGEMENT SUBSYSTEM DESIGN	E - 24
TASK 4. PP&C SUBSYSTEM DEVELOPMENT	E - 24
SUBTASK 4.1 ELECTRICAL COMPONENTS	E - 24
SUBTASK 4.2 SOFTWARE	E - 25
TASK 5. GROUND ENGINEERING SYSTEM (GES) TESTING	E - 25
TASK 5.1 GES DESIGN.....	E - 25
TASK 5.2 GES PERFORMANCE TESTS	E - 26
TASK 5.3 GES LIFE TEST	E - 26
TASK 6. QUALIFICATION PROGRAM TESTING.....	E - 27
SUBTASK 6.1 QUALIFICATION PERFORMANCE TESTING	E - 29
SUBTASK 6.2 QUALIFICATION LIFE TESTING (OPTIONAL)	E - 29
TASK 7. FLIGHT UNIT (FU) SYSTEM PROGRAM	E - 30
SUBTASK 7.2 FU ASSEMBLY, TEST, AND PAYLOAD INTEGRATION.....	E - 31
SUBTASK 7.3 FU LAUNCH SUPPORT	E - 31
DEVELOPMENT SCHEDULE.....	E - 31
REFERENCES.....	E - 33
APPENDIX F - THERMIONIC REACTOR SYSTEM TECHNOLOGY ROADMAP.....	F - 1
INTRODUCTION	F - 1
CONCEPT DESCRIPTION	F - 1
TECHNOLOGY ISSUES	F - 4

TABLE OF CONTENTS (CONTINUED)

TECHNOLOGY ASSESSMENT.....	F - 4
THERMIONIC POWER REACTOR STATE-OF-THE-ART.....	F - 5
THERMIONIC POWER CONVERSION UNIT (PCU) STATE-OF-THE-ART	F - 6
HEAT REJECTION SUBSYSTEM (HRS) STATE-OF-THE-ART	F - 7
POWER PROCESSING AND CONTROLS STATE-OF-THE-ART	F - 8
MAJOR DEVELOPMENT TASKS.....	F - 8
TASK 1. THERMIONIC POWER REACTOR DEVELOPMENT.....	F - 9
TASK 2. THERMIONIC PCS DEVELOPMENT	F - 9
TASK 3. HRS DEVELOPMENT	F - 9
SUBTASK 3.1 HEAT PIPE DEMONSTRATION.....	F - 9
SUBTASK 3.2 RADIATOR ENHANCEMENT	F - 10
SUBTASK 3.3 HEAT PIPE INTEGRATION & TESTING.....	F - 10
SUBTASK 3.4 HRS DESIGN, ASSEMBLY, FABRICATION & TESTING	F - 11
TASK 4. PP&C DEVELOPMENT.....	F - 11
TASK 5. GROUND ENGINEERING SYSTEM (GES) TESTING	F - 12
TASK 6. QUALIFICATION PROGRAM	F - 13
TASK 7. FLIGHT SYSTEM PROGRAM	F - 14
DEVELOPMENT SCHEDULE.....	F - 15
REFERENCES.....	F - 18
APPENDIX G - SP-100 SYSTEM TECHNOLOGY ROADMAP	G - 1
INTRODUCTION	G - 1
CONCEPT DESCRIPTION.....	G - 1
KEY ISSUES.....	G - 6
TECHNOLOGY ASSESSMENT.....	G - 7
SP-100 SPACE REACTOR AND PRIMARY LOOP STATE-OF-THE-ART	G - 7
THERMOELECTRIC POWER CONVERSION DEVICE STATE-OF-THE-ART.....	G - 11
HEAT REJECTION SUBSYSTEM (HRS) STATE-OF-THE-ART	G - 12
POWER PROCESSING AND CONTROLS (PP&C) STATE-OF-THE-ART	G - 14
MAJOR DEVELOPMENT TASKS.....	G - 15
TASK 1. SP-100 SPACE POWER REACTOR DEVELOPMENT	G - 15
TASK 2. THERMOELECTRIC POWER CONVERSION DEVICE DEVELOPMENT.....	G - 16
TASK 3. HRS DEVELOPMENT	G - 17
SUBTASK 3.1 HEAT PIPE DEMONSTRATION.....	G - 17
SUBTASK 3.2 RADIATOR ENHANCEMENT	G - 17
SUBTASK 3.3 HEAT PIPE INTEGRATION AND TESTING	G - 18
SUBTASK 3.4 HRS DESIGN, ASSEMBLY, FABRICATION, AND TESTING.....	G - 18
TASK 4. POWER PROCESSING AND CONTROLS DEVELOPMENT	G - 18
TASK 5. GROUND ENGINEERING SYSTEM (GES) TESTING	G - 19
TASK 6. QUALIFICATION PROGRAM	G - 21
TASK 7. FLIGHT SYSTEM PROGRAM	G - 22
DEVELOPMENT SCHEDULE.....	G - 22
REFERENCES.....	G - 25
APPENDIX H - DYNAMIC SP-100 SYSTEM TECHNOLOGY ROADMAP.....	H - 1
INTRODUCTION	H - 1
CONCEPT DESCRIPTION.....	H - 2
KEY ISSUES.....	H - 8
TECHNOLOGY ASSESSMENT.....	H - 9
SP-100 SPACE REACTOR STATE-OF-THE-ART	H - 10
POTASSIUM RANKINE PCU STATE-OF-THE-ART	H - 11
BRAYTON CYCLE PCU STATE-OF-THE-ART	H - 12
STIRLING CYCLE PCU STATE-OF-THE-ART	H - 13

TABLE OF CONTENTS (CONCLUDED)

RADIATOR STATE-OF-THE-ART.....	H-16
PP&C STATE-OF-THE-ART.....	H-16
MAJOR DEVELOPMENT TASKS.....	H-17
TASK 1. INTERMEDIATE HEAT EXCHANGER (INTEGRATION OF REACTOR AND PCU) .	H-17
TASK 2. POWER CONVERSION UNIT DEVELOPMENT.....	H-18
TASK 3. RADIATOR INTEGRATION WITH PCU.....	H-18
TASK 4. GROUND ENGINEERING SYSTEM (GES) TESTING.....	H-18
TASK 5. QUALIFICATION PROGRAM.....	H-20
TASK 6. FLIGHT SYSTEM PROGRAM.....	H-22
DEVELOPMENT SCHEDULES.....	H-22
REFERENCES.....	H-27

LIST OF FIGURES

FIGURE A-1. CBC DIPS CYCLE DIAGRAM.....	A - 4
FIGURE A-2. CONCEPTUAL DESIGN OF 2.5 KWE CBC DIPS POWER CART	A - 5
FIGURE A-3. 2.5 KWE DIPS HSU.....	A - 5
FIGURE A-4. GPHS MODULE (250 W) SECTIONS AT MID-PLANE.....	A - 8
FIGURE A-5. MODULAR CBC DIPS PCU COMPONENTS.....	A - 9
FIGURE A-6. CBC DIPS TPTL GAS COOLED TAC DESIGN.....	A - 10
FIGURE A-7. CBC DIPS RECUPERATOR.....	A - 11
FIGURE A-8. GAS TUBE-AND-FIN RADIATOR ASSEMBLY.....	A - 12
FIGURE A-9. DIPS PP&C ARCHITECTURE DIAGRAM.....	A - 14
FIGURE A-10. DIPS QUALIFICATION PROGRAM.....	A - 34
FIGURE A-11. DIPS ASSEMBLY QUALIFICATION TEST MATRIX.....	A - 35
FIGURE A-12. DIPS QU TEST SEQUENCE.....	A - 35
FIGURE A-13. 2.5 KWE CBC DIPS DEVELOPMENT SCHEDULE.....	A - 38
FIGURE B-1. PEM RFC POWER SYSTEM SCHEMATIC.....	B - 2
FIGURE B-2. ACID PEM ELECTROCHEMICAL CELL REACTIONS.....	B - 4
FIGURE B-3. FUEL CELL PRODUCT WATER DEOXYGENATOR.....	B - 4
FIGURE B-4. OXYGEN AND HYDROGEN PHASE SEPARATORS IN ELECTROLYZER STACK.....	B - 6
FIGURE B-5. THERMAL MANAGEMENT SUBSYSTEM.....	B - 8
FIGURE B-6. SPE® FUEL CELL REACTANT PREHUMIDIFICATION APPROACH.....	B - 11
FIGURE B-7. WATER RECOVERY FROM THE OXYGEN REGENERATIVE DRYER.....	B - 11
FIGURE B-8. RFC POWER SYSTEM QUALIFICATION PROGRAM.....	B - 41
FIGURE B-9. RFC POWER SYSTEM ASSEMBLY QUALIFICATION TEST MATRIX.....	B - 42
FIGURE B-10. RFC POWER SYSTEM QU TEST SEQUENCE.....	B - 42
FIGURE B-11. PEM RFC POWER SYSTEM DEVELOPMENT SCHEDULE.....	B - 45
FIGURE C-1. BATTERY SYSTEM SCHEMATIC.....	C - 2
FIGURE C-2. NAS BATTERY CELL OPERATION DURING DISCHARGE.....	C - 3
FIGURE C-3. TYPICAL TUBULAR NAS BATTERY CELL DESIGN.....	C - 4
FIGURE C-4. NAS BATTERY POWER SYSTEM QUALIFICATION PROGRAM.....	C - 21
FIGURE C-5. NAS BATTERY ASSEMBLY QUALIFICATION TEST MATRIX.....	C - 22
FIGURE C-6. QU TEST SEQUENCE.....	C - 22
FIGURE C-7. NAS BATTERY POWER SYSTEM DEVELOPMENT SCHEDULE.....	C - 24
FIGURE D-1. PV/RFC POWER SYSTEM SCHEMATIC	D - 3
FIGURE D-2. TANDEM CELL SCHEMATIC	D - 4
FIGURE D-3. ACID PEM ELECTROCHEMICAL CELL REACTIONS.....	D - 9
FIGURE D-4. FUEL CELL PRODUCT WATER DEOXYGENATOR	D - 10
FIGURE D-5. OXYGEN AND HYDROGEN PHASE SEPARATORS IN ELECTROLYZER STACK.....	D - 12
FIGURE D-6. THERMAL MANAGEMENT SUBSYSTEM.....	D - 14
FIGURE D-7. SPE FUEL CELL REACTANT PREHUMIDIFICATION APPROACH.....	D - 16
FIGURE D-8. WATER RECOVERY FROM THE OXYGEN REGENERATIVE DRYER.....	D - 17
FIGURE D-9. PV/RFC POWER SYSTEM QUALIFICATION PROGRAM.....	D - 42
FIGURE D-10. PV/RFC POWER SYSTEM ASSEMBLY QUALIFICATION TEST MATRIX.....	D - 43
FIGURE D-11. PV/RFC POWER SYSTEM QU TEST SEQUENCE.....	D - 43
FIGURE D-12. PV/RFC POWER SYSTEM DEVELOPMENT SCHEDULE.....	D - 46

LIST OF FIGURES (CONTINUED)

FIGURE E-1. PV/BATTERY SYSTEM SCHEMATIC	E - 2
FIGURE E-2. TANDEM PV CELL SCHEMATIC	E - 4
FIGURE E-3. NAS BATTERY CELL OPERATION DURING DISCHARGE.....	E - 7
FIGURE E-4. TYPICAL TUBULAR NAS BATTERY CELL DESIGN.....	E - 8
FIGURE E-5. PV/BATTERY POWER SYSTEM QUALIFICATION PROGRAM	E - 27
FIGURE E-6. PV/BATTERY POWER SYSTEM ASSEMBLY QUALIFICATION TEST MATRIX	E - 28
FIGURE E-7. PV/BATTERY POWER SYSTEM QU TEST SEQUENCE.....	E - 29
FIGURE E-8. GaAs-CIS PV ARRAY/NAS BATTERY POWER SYSTEM DEVELOP. SCHEDULE ...	E - 31
FIGURE F-1. DRIVER FUEL IN-CORE TFE SYSTEM CONCEPT	F - 3
FIGURE F-2. THERMIONIC POWER SYSTEM QU TEST SEQUENCE	F - 15
FIGURE F-3. FUEL DRIVER IN-CORE TFE POWER SYSTEM DEVELOPMENT SCHEDULE	F - 17
FIGURE G-1. SP-100 TE GENERIC FLIGHT SYSTEM CONFIGURATION.....	G - 2
FIGURE G-2. RADIATOR INTERFACE WITH HEAT TRANSPORT PIPING	G - 4
FIGURE G-3. THERMOELECTRIC CELL DESIGN.....	G - 5
FIGURE G-4. SP-100 HARDWARE DEVELOPMENT.....	G - 8
FIGURE G-5. SP-100 CONDUCTIVELY COUPLED MULTICOUPLE EVOLUTION.....	G - 13
FIGURE G-6. QU TEST SEQUENCE.....	G - 22
FIGURE G-7. SP-100 TE GENERIC FLIGHT SYSTEM DEVELOPMENT SCHEDULE.....	G - 24
FIGURE H-1. 550 KWE BRAYTON CYCLE POWER SYSTEM SCHEMATIC	H - 4
FIGURE H-2. 550 KWE STIRLING CYCLE POWER SYSTEM SCHEMATIC	H - 4
FIGURE H-3. POTASSIUM RANKINE CYCLE POWER SYSTEM SCHEMATIC	H - 5
FIGURE H-4. 550 KWE LUNAR SURFACE POWER SYSTEM CONFIGURATIONS	H - 6
FIGURE H-5. BURIED 550 KWE LUNAR SURFACE POWER SYSTEM INSTALLATION	H - 7
FIGURE H-6. QU TEST SEQUENCE	H - 21
FIGURE H-7. SC DYNAMIC SP-100 DEVELOPMENT SCHEDULE.....	H - 24
FIGURE H-8. CBC DYNAMIC SP-100 DEVELOPMENT SCHEDULE.....	H - 25
FIGURE H-9. PRC DYNAMIC SP-100 DEVELOPMENT SCHEDULE	H - 26

LIST OF TABLES

TABLE A-1. DIPS TECHNOLOGY ISSUES, IMPACTS, AND DEVELOPMENT AREAS.....	A - 15
TABLE A-2. 1133 °K (1579 °F) CBC DIPS TECHNOLOGY ASSESSMENT.....	A - 17
TABLE A-3. LITHIUM HEAT PIPE OPERATING EXPERIENCE	A - 19
TABLE A-4. APU FOIL GAS BEARING EXPERIENCE.....	A - 20
TABLE A-5. APPLICABLE CBC RECUPERATOR EXPERIENCE.....	A - 22
TABLE A-6. WATER AND AMMONIA HEAT PIPE EXPERIENCE.....	A - 24
TABLE B-1. FUEL CELL DESIGN OPTION POWER DENSITY COMPARISON.....	B - 5
TABLE B-2. ELECTROLYZER DESIGN OPTION POWER DENSITY COMPARISON	B - 7
TABLE B-3. PEM RFC DEVELOPMENT ISSUES, IMPACTS & DEVELOPMENT AREAS.....	B - 14
TABLE B-4. PROJECTED ELECTROLYSIS CELL MEMBRANE LIFE	B - 19
TABLE B-5. RFC TECHNOLOGY ASSESSMENT.....	B - 22
TABLE C-1. NaS BATTERY SUBSYSTEM ISSUES, IMPACTS & DEVELOPMENT AREAS.....	C - 9
TABLE C-2. NaS BATTERY TECHNOLOGY ASSESSMENT	C - 9
TABLE D-1. FUEL CELL DESIGN OPTION POWER DENSITY COMPARISON.....	D - 10
TABLE D-2. ELECTROLYZER DESIGN OPTION POWER DENSITY COMPARISON	D - 11
TABLE D-3. PV SUBSYSTEM ISSUES, IMPACTS & DEVELOPMENT AREAS.....	D - 19
TABLE D-4. PEM RFC DEVELOPMENT ISSUES.....	D - 20
TABLE D-5. PV/RFC TECHNOLOGY ASSESSMENT.....	D - 21
TABLE D-6. DESCRIPTION OF VARIOUS ARRAY TECHNOLOGIES.....	D - 23
TABLE E-1. PV SUBSYSTEM ISSUES, IMPACTS & DEVELOPMENT AREAS.....	E - 13
TABLE E-2. NaS BATTERY SUBSYSTEM ISSUES, IMPACTS & DEVELOPMENT AREAS.....	E - 13
TABLE E-3. GaAs-CIS PV/NaS BATTERY TECHNOLOGY ASSESSMENT.....	E - 14
TABLE E-4. DESCRIPTION OF VARIOUS ARRAY TECHNOLOGIES	E - 16
TABLE F-1. SUMMARY OF KEY ISSUES, IMPACTS & DEVELOPMENT AREAS	F - 4
TABLE F-2. IN-CORE TI TECHNOLOGY ASSESSMENT	F - 5
TABLE G-1. SP-100 GENERIC FLIGHT SYSTEM DESIGN GOALS	G - 3
TABLE G-2. SUMMARY OF KEY ISSUES AND IMPACTS.....	G - 6
TABLE G-3. SP-100 TECHNOLOGY ASSESSMENT	G - 7
TABLE H-1. KEY ISSUES, IMPACTS, AND DEVELOPMENT AREAS.....	H - 8
TABLE H-2. DYNAMIC SP-100 TECHNOLOGY ASSESSMENT.....	H - 9
TABLE H-3. OPERATING TIMES WITH K AND CS POWER CONVERSION SUBSYSTEMS AND COMPONENTS AT TEMPERATURES ABOVE 810 K.....	H - 12
TABLE H-4. FREE PISTON STIRLING ENGINE ACCUMULATED TEST TIMES	H - 15
TABLE H-5. REFRACTORY METAL CANDIDATES FOR 1300 °K STIRLING.....	H - 16

NOMENCLATURE

AMTEC	=	Alkali metal thermoelectric converter
BIPS	=	Brayton Isotope Power System
BRU	=	Brayton Rotating Unit
C-C	=	Carbon-carbon
CBC	=	closed Brayton cycle
CIS	=	copper indium selenide
D	=	day
DIPS	=	dynamic isotope power system
EOL	=	end-of-life
EPS	=	electrical power system
FLO	=	First Lunar Outpost
FU	=	Flight Unit
GaAs/Ge	=	gallium arsenide on germanium base photovoltaic cell
GES	=	Ground Engineering System
GPHS	=	General Purpose Heat Source
HP	=	high pressure
HSU	=	heat source unit
ISTU	=	Integrated System Test Unit
LMCR	=	liquid metal cooled reactor
MEV	=	Mars excursion vehicle
MFI	=	multifoil insulation
N	=	night
NaS	=	sodium sulfur
OSR	=	optical solar reflector
P	=	peak
PCU	=	power conversion unit
PEM	=	proton exchange membrane
PCCU	=	power conditioning and control unit
PMG	=	permanent magnet generator
PP&C	=	power processing and control
PV	=	photovoltaic
QU	=	Qualification Unit
RFC	=	regenerative fuel cell
RHRS	=	reversible heat rejection system
RTG	=	radioisotope thermoelectric generator
SC	=	Stirling cycle
SEI	=	Space Exploration Initiative
SSF	=	Space Station Freedom
TAC	=	turboalternator compressor
TE	=	thermoelectric
TFE	=	thermionic fuel element
TPTL	=	two pole toothless
TRL	=	technical readiness level

APPENDIX A

INTRODUCTION

The following technology development plan discusses the reference power system design for the U.S. Department of Energy Dynamic Isotope Power System program and describes the development program needed to deploy this system as a primary source of power for lunar and Mars surface exploration missions. It specifically addresses the development tasks required to deploy a modular 2.5 kWe DIPS for the First Lunar Outpost mission (FLO), in 1999 and to design the DIPS module to be compatible with the Martian surface environment.

DIPS technology is suitable for use in both fixed and mobile power applications for the lunar or Martian surface as well as a reliable power source for space satellites. For fixed bases and mobile surface power system applications, the current DIPS program has focused on a standard power module design of 2.5 kWe. Surface power systems in the range of 1 kWe to 20 kWe can be developed from this standard module design.

A variety of potential DIPS remote or mobile applications have been identified by the National Aeronautics and Space Administration (NASA). These applications include remote power to science packages, surface rovers for both short and extended duration missions, and backup to central base power (Ref. A-1). For the scenarios and applications associated with the Space Exploration Initiative (SEI), a trade study was conducted which resulted in the selection of a standard power module design as the preferred approach (Ref. A-2). A 2.5 kWe power level was identified as the optimum module size. This trade study evaluated various cycle design options, turbine inlet temperature effects, technology readiness levels, development time, as well as overall power system costs, including delivery and support on the Moon and Mars. The 2.5 kWe power module approach had overall cost, schedule and technical advantages over application specific designs.

The use of multiple modular power units to supply power needs has many advantages. Modular units permit the development of a single-size module reducing development costs and it improving the power availability factor for most applications. These modular units are

replaceable if a unit failure occurs. The fuel is simply removed from the failed unit and reused in a replacement unit providing a 100% fuel utilization factor with the use of non-fueled spares. For mobile units, sufficient capacity would be installed such that if one power module were to fail, the mobile unit could return to base.

The modular DIPS design requirements include a 15 year continuous lifetime. The fuel handling canister is designed for a 45 year life thereby allowing for the reuse of the fuel in future unfueled DIPS replacement modules. The fuel is transported only once to the destination and unfuel spare modules are sent as needed for the mission. After the initial 15 year lifetime, the output power level would decrease at the rate of 0.8% per year down to 2.2 kWe at 30 years if no improvements were included in the future unfueled DIPS modules.

The DIPS system is required to operate in the rigors of the Martian environment as well as the lunar surface environment. This design challenge was accomplished by confining the use of refractory alloy materials to components located within the sealed heat source unit and utilizing protective coatings and vacuum jackets where refractory alloy materials might be exposed to the Martian environment even for short times during fuel canister transfer. The turbine inlet temperature for the working fluid was limited to 1133 °K (1579 °F) to insure that the gas containment boundary is totally constructed of nonrefractory alloy materials. Early in the trade studies, it was determined that higher temperature systems did not provide a significant improvement in system performance. This design change eliminated the need for high temperature dissimilar metal joints in the gas containment boundary and resulted in an all welded joint construction for the DIPS with a significant lowering of development costs and a faster development schedule. In addition, simplification of the system design was achieved by using a gas cooled permanent magnet alternator design which reduced the number of moving parts to one and simplified the method of voltage control. This design change resulted in a significant improvement in the overall system reliability, and provided additional improvements in unit cost, system efficiency and specific mass.

CONCEPT DESCRIPTION

The DIPS uses the decay of radioactive plutonium 238 as the source of heat and a closed Brayton cycle (CBC) power conversion cycle to convert this heat to electrical power. The CBC DIPS cycle diagram is illustrated in Figure A-1. The CBC uses an inert gas working fluid (helium-xenon mixture) which is heated by the radioactive heat source and then expanded through a turbine to convert heat energy to mechanical energy. From the turbine, the working fluid passes through a recuperator to recover heat and improve cycle efficiency. The waste heat from the cycle is then rejected through a gas tube and fin radiator assembly. From the radiator, the working fluid is compressed to the peak cycle pressure and then used to cool the alternator. The working fluid again passes through the recuperator for preheat before returning to the heat source.

The DIPS working fluid is contained within a loop that is hermetically sealed containing all full penetration inspectable welds. There are no valves or contacting mechanical parts that could cause wear and limit lifetime. The turboalternator permanent magnet rotor is suspended on noncontacting working fluid gas foil bearings, and there are no contacting seals or brushes.

Figure A-2 shows a conceptual layout of the system associated with a cart to provide mobility. The heat source units (HSUs) are located under the radiators and include fuel handling canisters that contain multiple General Purpose Heat Source (GPHS) modules. Figure A-3 shows an example of a typical HSU. The HSUs contain a reversible heat removal system (RHRS) that allows the radioisotope heat to be dissipated to space in the event the power conversion cycle is not operating.

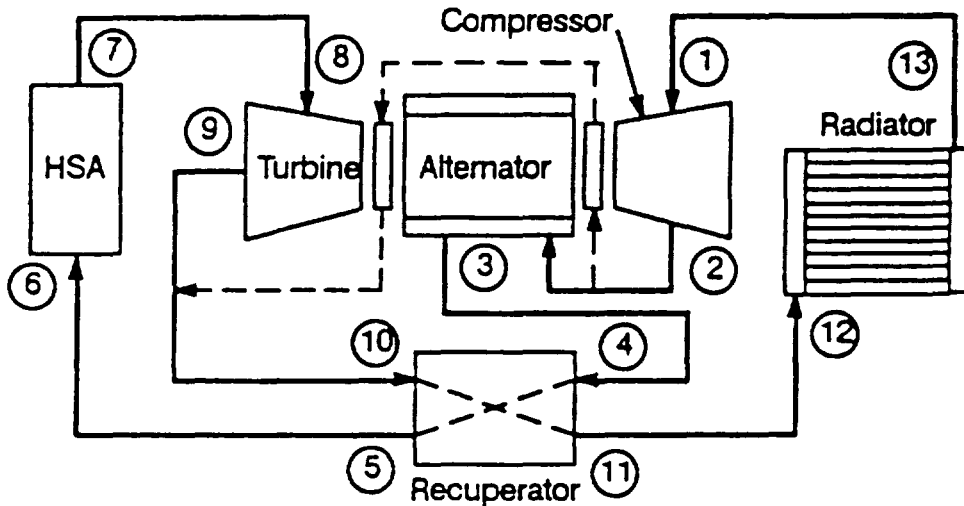

No.	Stream	Temperature (K)	Pressure (kPa)	Flow (kg/s)
1	Compressor inlet	360.83	321.50	0.2007
2	Compressor discharge	469.23	538.55	0.2007
3	Alternator discharge	475.39	538.55	0.1987
4	HP recuperator inlet	475.39	536.69	0.1987
5	HP recuperator outlet	929.87	534.97	0.1987
6	HSA inlet	926.52	533.86	0.1987
7	HSA outlet	1136.67	531.59	0.1987
8	Turbine inlet	1133.31	530.49	0.1987
9	Turbine outlet	960.97	327.78	0.1987
10	LP recuperator inlet	953.79	327.16	0.2008
11	LP recuperator outlet	503.90	325.57	0.2008
12	Radiator inlet	503.90	324.88	0.2008
13	Radiator outlet	360.83	322.81	0.2008

Figure A-1. - CBC DIPS cycle diagram.

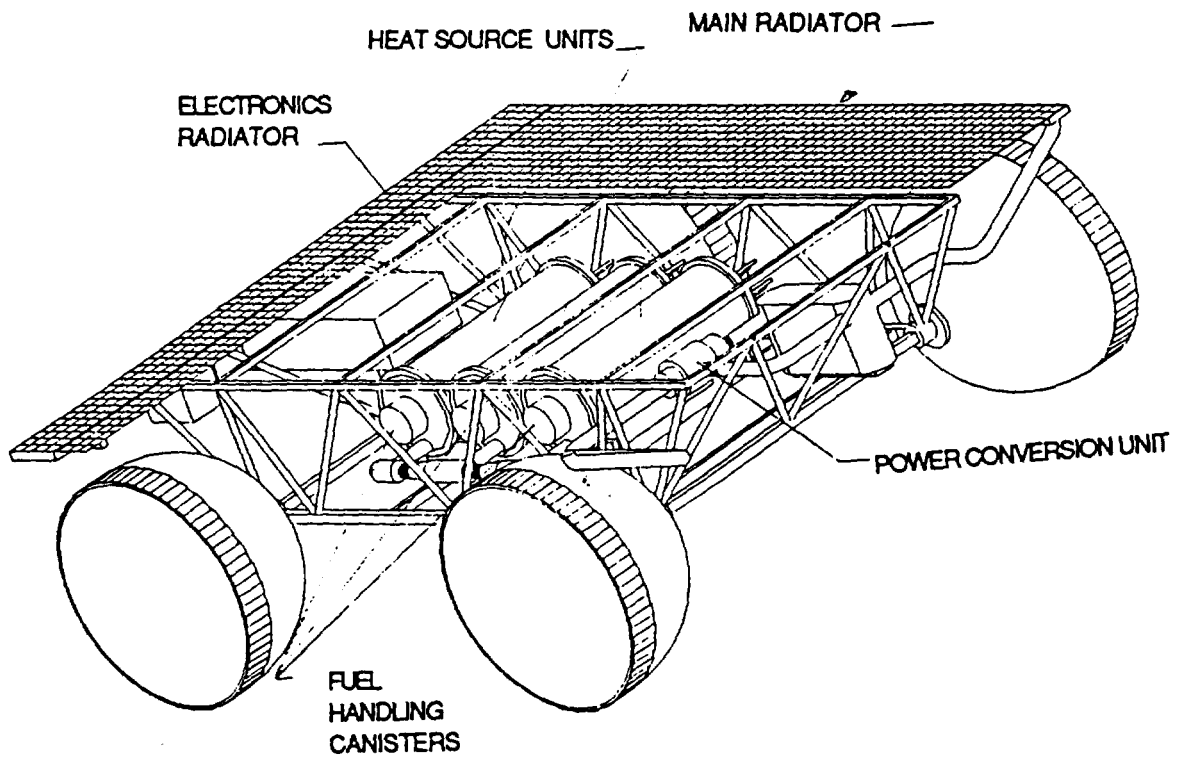

Figure A-2. Conceptual design of 2.5 kWe modular CBC DIPS power cart.

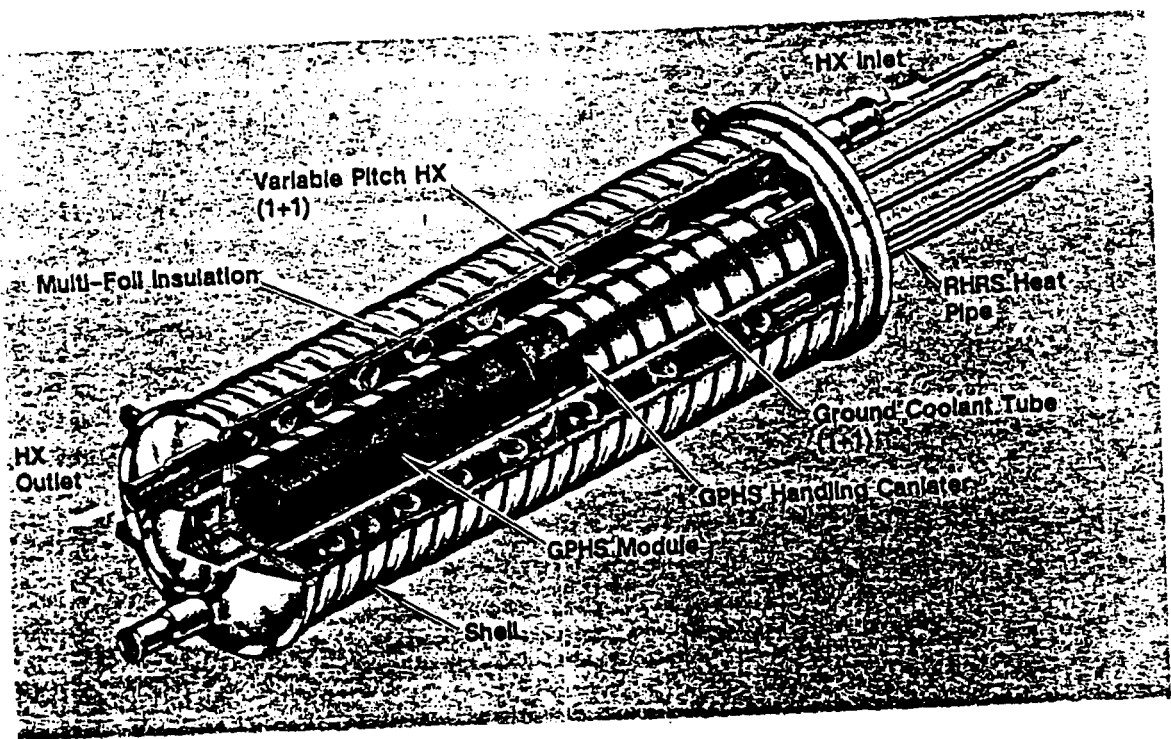

Figure A-3. 2.5 kWe DIPS HSU.

Typically, the DIPS heat source assembly consists of three heat source units (HSUs) plumbed together in parallel. This parallel piping connection provides a low pressure drop heat exchanger design. Each HSU fuel handling canister contains multiple GPHS modules and is removable from the HSU housing. The fuel handling canister is fabricated of Nb-1Zr which is coated with titanium diboride for emissivity control and oxidation protection from the Martian atmosphere. This coating must provide protection only while the canisters are being transferred from their transport and storage rack units to each HSU housing which would require less than one hour. The oxidation environment within the canister is minimized by providing a niobium wire wool getter to absorb the CO₂ diffusing through the helium release membrane and a niobium wire wrap at the slip joint end to "getter" any oxidizing atmosphere within the vacuum liner to canister annulus. A perfluoroelastomer O-ring seals the annulus to minimize CO₂ ingress. The canister materials and design were chosen to provide a viable concept able to meet the lifetime goal for either lunar or Martian missions. The getters would not be required for lunar surface operations.

The HSU is composed of a multiple coil, helical pitch heat exchanger, multifoil insulation (MFI), MFI vacuum liner, reversible heat removal system (RHRS), and an outer shell. The heat exchanger will be fabricated from Inconel 617 with its outer surface coated with titanium diboride for emissivity control. Since the heat exchanger will be in a vacuum container, the emissive coating must only be able to accommodate the time-temperature intermetallic diffusion.

Backup cooling for the HSU is provided in the event the gas cooling loop is inactive. Variable conductance heat pipes provide a RHRS which can safely reject all the isotope heat at slightly above normal operating temperatures after the turbine gas flow stops.

The RHRS variable conductance heat pipes are provided to insure that the HSU component temperatures remain at acceptable levels before system start-up or during a temporary shutdown. They reject very little heat during normal operation of the DIPS. The heat pipes selected for this application use lithium as the working fluid. Neon is added as a noncondensable

gas to limit heat loss at operating temperatures. The heat pipe containment boundary and wick will be made of Nb-1%Zr. As in the other internal HSU components, TiB_2 is used as an emissivity coating. For compatibility with the Martian environment, the condenser and gas reservoir sections are covered with a pre-oxidized Inconel 617 vacuum liner which protects the refractory metal from attack by the CO_2 rich Martian atmosphere. The vacuum enclosure is not necessary for use on the lunar surface and can be removed. In either application the entire heat pipe sees only vacuum conditions.

In the unlikely event that the gas loop and all the RHRS heat pipes are inoperative, the isotope fuel clad temperature is still maintained in a safe level due to the HSU meltable MFI insulation package. The MFI consists of 130 layers of foil which are designed to melt and provide a direct cooling path to space before damage to the fuel cladding occurs after loss of all other cooling. There are 80 layers of 0.0005 cm thick niobium surrounded by 50 layers of 0.00086 cm thick nickel, all separated by yttria particles. To assure integrity in the Martian environment, the insulation is contained within an evacuated chamber enveloped by the shell, liner, and end caps. Although not essential for lunar applications, the MFI vacuum liner provides for lunar/Mars compatibility with a mass penalty of less than 1.5 kg.

The GPHS module developed by the U.S. Department of Energy serves as the isotopic heat source in DIPS. The design of the GPHS module is shown in Figure A-4. There are 17 GPHS modules per HSU in the current 2.5 kWe modular DIPS design.

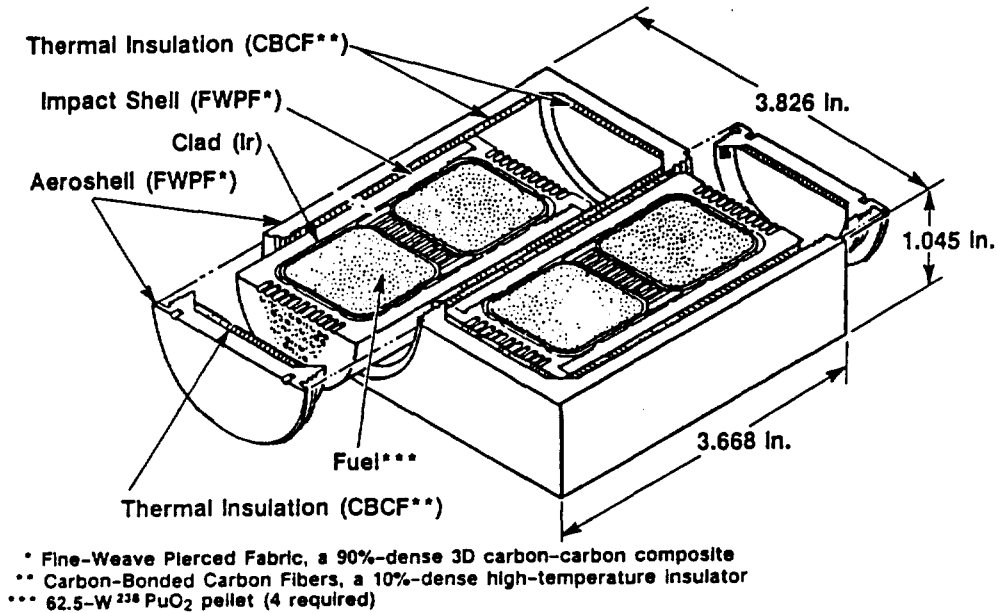

Figure A-4. GPHS Module (250 W) Sectioned at Mid-Plane.

The DIPS Power Conversion Unit (PCU) is shown in Figure A-5. The PCU consists of a turboalternator compressor (TAC), recuperator, and interconnecting ducting. The high temperature interconnect ducting is made of Inconel and the low temperature ducting of aluminum or stainless steel. The TAC consists of a turbine, alternator and compressor mounted on a single common shaft supported by radial and axial foil gas bearings. A typical cross section of the TAC is shown in Figure A-6. The 1133 °K turbine inlet temperature is within demonstrated CBC technology for long-duration mission requirements using conventional super alloys. The top half of the figure shows a TAC cross-section for the reference turbine inlet temperature. The bottom half shows a advanced double wall scroll design for a 1300 °K turbine inlet temperature system. Significant design features of the TAC are called out on the figure. The turbine, alternator, and compressor are all located on a single solid shaft. The shaft, or

rotating unit, is supported on hydrodynamic gas foil bearings so there are no rubbing parts to wear out. The TAC and its entire gas containment boundary are hermetically sealed with all joints fully inspectable per visual, dye penetrant, magnetic particle, and x-ray methods.

The TAC employs a two pole toothless (TPTL) permanent magnet generator (PMG). The TPTL PMG design consists of a permanent (Samarium-Cobalt) magnet encased in a sleeved rotor, as shown in the figure. The permanent magnet field eliminates the need for field coils and their associated losses. The high strength field results in the elimination of the stator teeth and their resultant weight and pole face loss penalties. The TAC design provides improved efficiency, lower cooling requirements, and lower unit weight when compared to the Rice alternator machine in this power range.

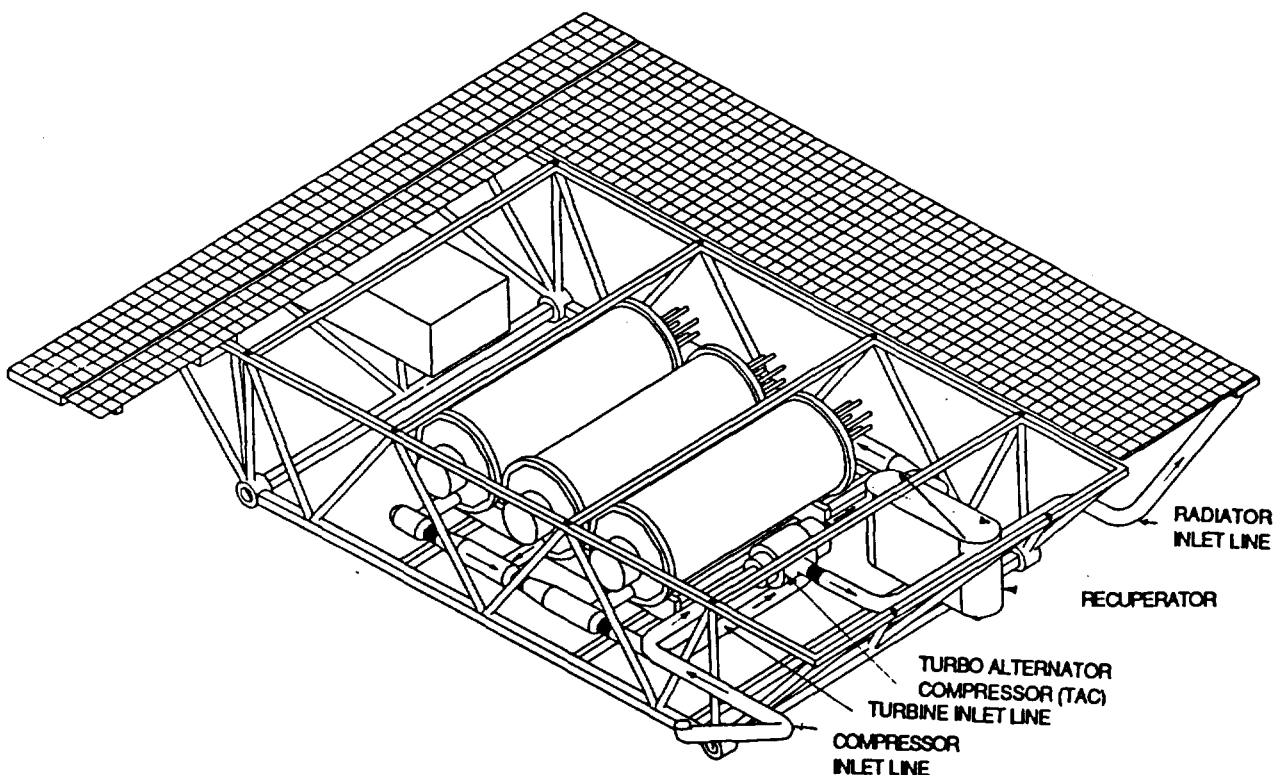

Figure A-5. Modular CBC DIPS PCU components.

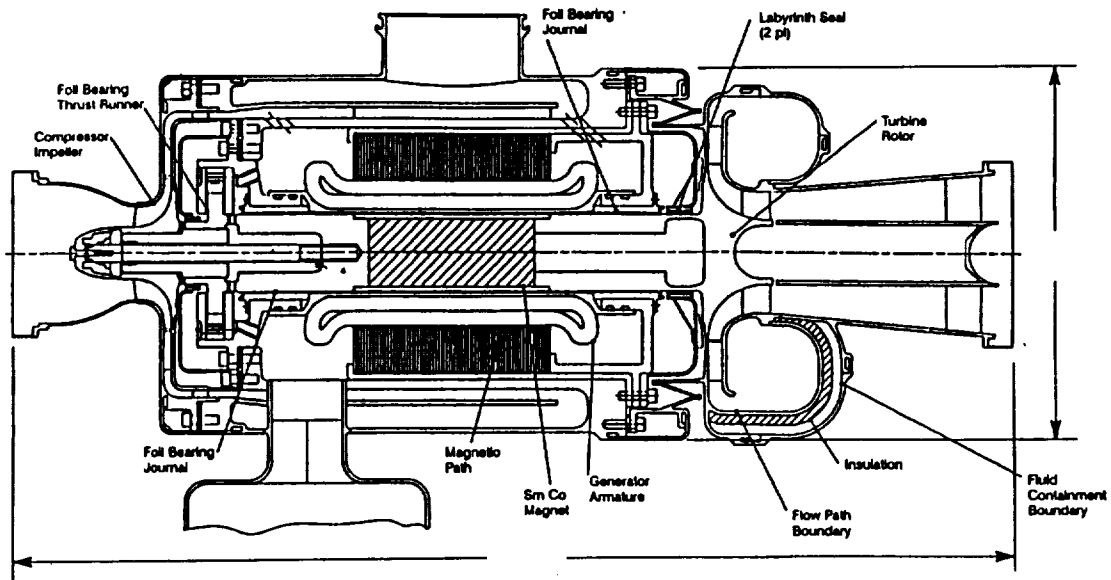

Figure A-6. CBC DIPS TPTL gas cooled TAC design.

A counterflow heat exchanger called a recuperator is used to increase PCU cycle efficiency. The recuperator consists of a compact, brazed, plate-fin heat exchanger core, and inlet and outlet fluid manifolds. The core matrix consists of a brazed assembly of rectangular offset fin counterflow sections. These sections are composed of alternate layers of high pressure (HP) He-Xe side and low pressure He-Xe side fins separated by metal plates. Figure A-7 illustrates the favored recuperator structure that uses the plate-fin sandwiches stacked to form the heat exchanger core with integral manifolds. This concept of construction proved very successful in the BIPS program. When stacked and brazed the tube-sheet forms (1) the flow separation plate in the offset fin matrix, (2) the first flow boundary of the end sections and sidewalls, and (3) the inlet and discharge flow plena. This type of construction has the benefit of totally eliminating thick-to-thin stress risers and weld-over-braze assembly requirements.

This design has proven to be both rugged and predictable as demonstrated in highly accelerated cyclic life testing conducted in support of the BIPS program.

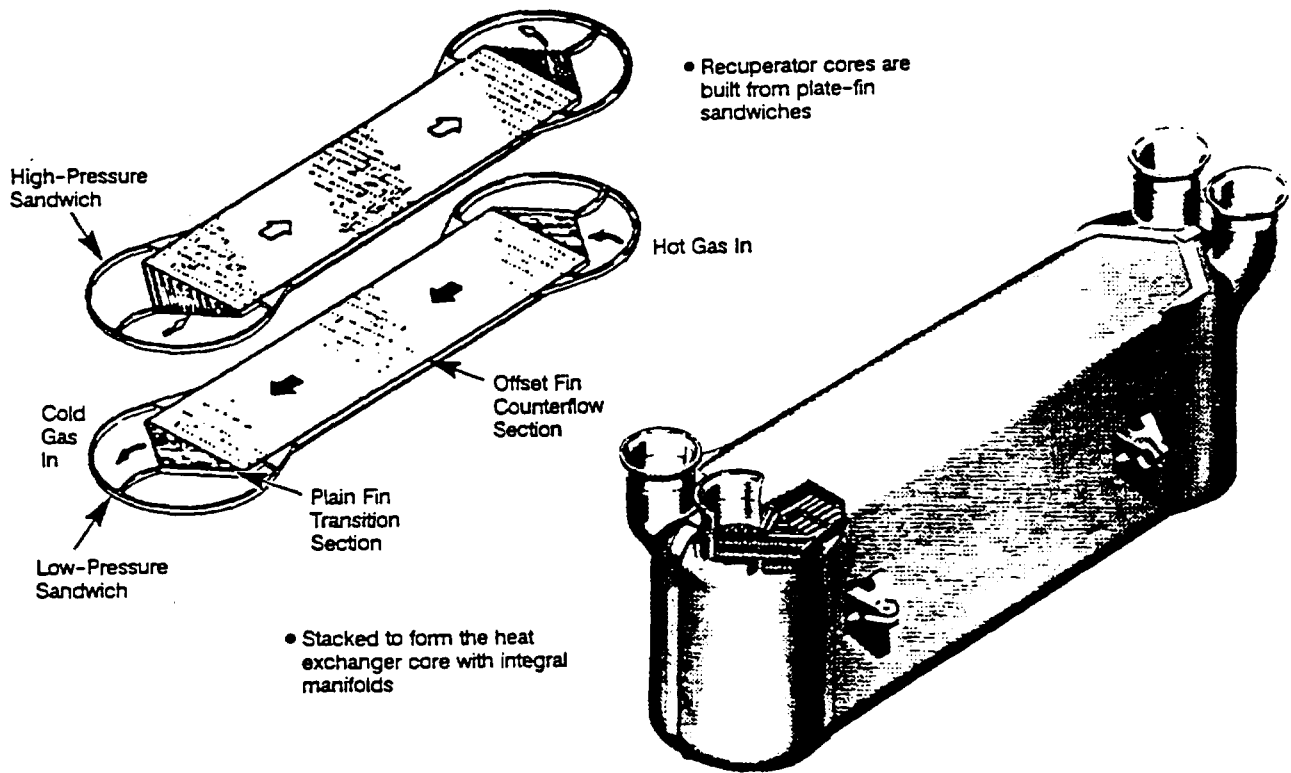

Figure A-7. CBC DIPS recuperator.

The main heat rejection radiator uses a conventional aluminum tube and fin assembly as shown in Figure A-8. The low pressure gas leaving the recuperator is cooled by passing through multiple parallel cooling tubes connected between inlet and outlet gas headers. The cooling tubes use highly efficient fins to develop radiating surface area. In combination with tube armor, these fins also serve as bumper armor to protect the gas tubes from meteoroid punctures. The gas tubes, headers, and fins are all constructed from aluminum alloys and all welds are fully inspectable. The finned radiating surface is covered with optical solar reflector (OSR) tiles to enhance the emissivity while limiting the absorption of solar energy ($\epsilon=0.8$, $\alpha_s=0.08$). These OSR tiles provide an effective sink temperature of 220K under lunar noon conditions for the DIPS radiators. Radiator surface coatings, such as Z93 ($\epsilon_s=0.9$, $\alpha_s=0.3$)

were rejected for the DIPS application due to their higher solar energy absorption coefficient. The use of paint on the DIPS radiator surface would raise the effective sink temperature for the DIPS by 56 °K requiring a larger radiator surface area even with its improved thermal emissivity value of 0.9. Since the radiator surface must always be exposed to the environment, degradation of this coating with exposure time which appears as primarily an increase in solar energy absorptivity, would further raise the effective sink temperature and degrade the DIPS cycle efficiency. The effects of lunar and Martian dust particles on radiating surface properties will be established during DIPS radiator tests.

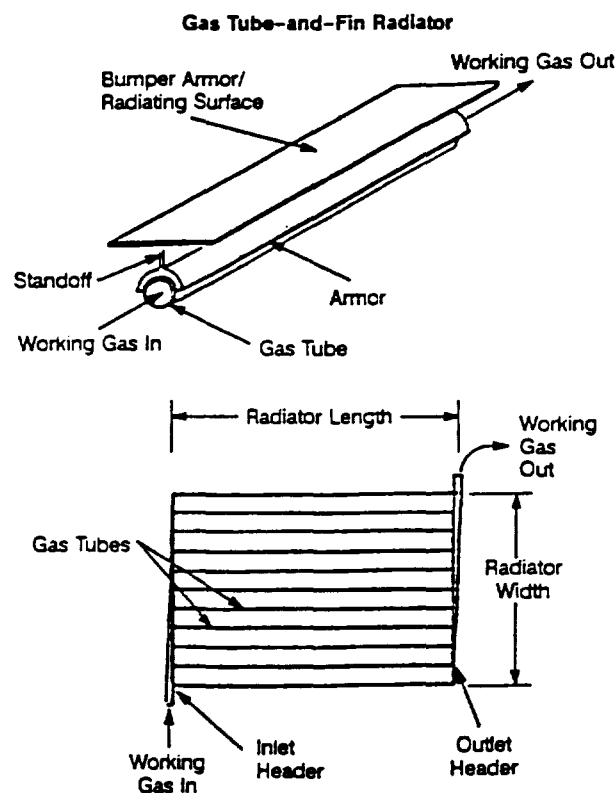

Figure A-8. Gas tube-and-fin radiator assembly.

In the current design, the DIPS power processing and control (PP&C) assembly consists of fully redundant power conditioning and control unit (PCCU) channels, a startup battery and battery control assembly, and the DIPS controller. The PCCU rectifies the ac power provided by the alternator and regulates the resulting 120 Vdc power output. This voltage was selected to

match the SSF electrical power subsystem architecture since it is anticipated that any future lunar outpost would share some features from the SSF EPS as a means of providing cost savings on future NASA missions (if it is determined that for some applications, that ac power is preferable, the PCCU can be designed to deliver three phase ac power to the user bus). The PCCU also supplies DIPS power needs during alternator start up. The DIPS controller monitors and controls the PCCU operation and provides a communications bus for external data transfer and control of the system. The PP&C architecture is illustrated in Figure A-9.

Each PCCU channel includes a switching rectifier, inverter, speed regulator, filter, battery control assembly, battery, and switching assembly. During normal operation, power conditioning is accomplished in three steps utilizing the switching rectifier, speed regulator, and filter. The active PCCU channel and operating configuration are designated by using the switches comprising the switch assembly.

Energy storage requirements are met by the battery assembly. It performs two functions: (1) it furnishes instrumentation and control power prior to the DIPS alternator startup, and (2) it provides the power needed to motor the alternator up to its self-sustaining speed. The battery assembly contains a battery control assembly and a battery consisting of eighty 2 amp-hour cells. The battery control assembly contains a voltage converter and a battery monitoring unit. The converter uses a boost regulator to control the battery charging rate. The battery monitoring unit controls the battery temperature and monitors its operating status.

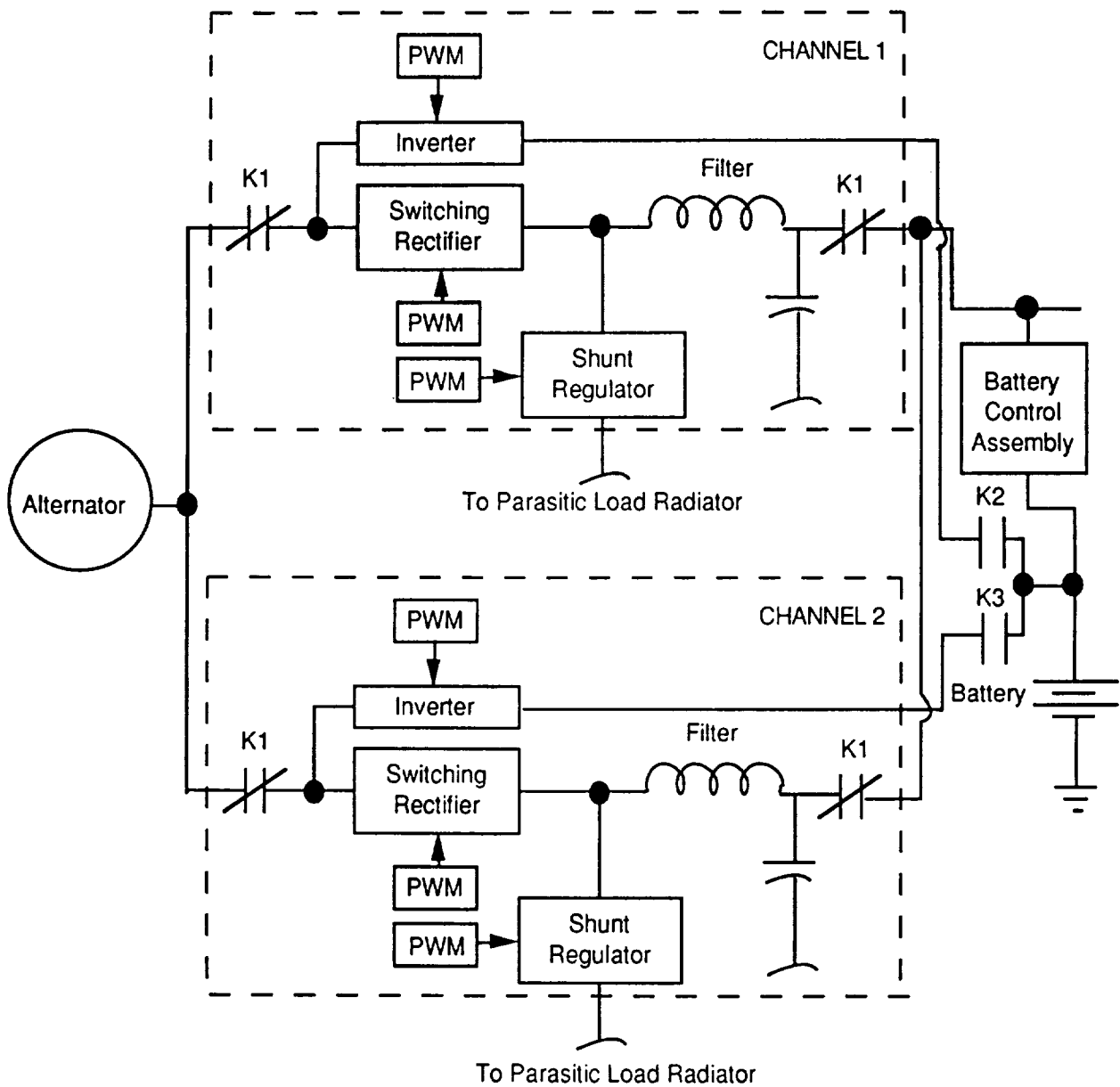

Figure A-9. DIPS PP&C architecture diagram.

CLOSED BRAYTON CYCLE DYNAMIC ISOTOPE POWER SYSTEM TECHNOLOGY ROADMAP

TECHNOLOGY ISSUES

The key issues for development of the baseline 1133 °K (1579 °F) DIPS concept and their system impacts are summarized in Table A-1.

TABLE A-1. DIPS TECHNOLOGY ISSUES, IMPACTS, AND DEVELOPMENT AREAS

Issue	Impact	Potential Development Areas
Isotope Cooling/ Nuclear Safety	<ul style="list-style-type: none"> •Active cooling during launch and flight •Passive emergency cooling 	<ul style="list-style-type: none"> •High emissivity coatings •RHRS heat pipes •Meltable MFI package
Lunar/Mars Environment	<ul style="list-style-type: none"> •Refractory metal lifetime •HSA mass increase 	<ul style="list-style-type: none"> •Coatings, getters, semi-permeable seals, dust protection, OSRs
Shock Loading	<ul style="list-style-type: none"> •Bearing lifetime •Reconfiguration of RHRS & electronics cooling radiator heat pipes 	<ul style="list-style-type: none"> •Gas-foil bearings performance •Heat pipe design and verification testing
Alternator Temperature	<ul style="list-style-type: none"> •Alternator mass and radiator area •Cooling system complexity 	<ul style="list-style-type: none"> •High temperature alternator insulation
Isotope Handling & Disposal	<ul style="list-style-type: none"> •Added mass for biological shielding •Added cost for non-recoverable isotope 	<ul style="list-style-type: none"> •Fuel handling canister and tools •Launch and transport containers
Recuperator Heat Transfer Performance	<ul style="list-style-type: none"> •System efficiency, mass, and radiator area 	<ul style="list-style-type: none"> •High performance laminar flow recuperator designs
Gas Leakage	<ul style="list-style-type: none"> •Life and reliability 	<ul style="list-style-type: none"> •Full-penetration inspectable welded boundaries •Low-temperature dissimilar metal transition joints •Meteoroid protection

TECHNOLOGY ASSESSMENT

The DIPS Demonstration Program is focused on advanced technology development of dynamic space power systems to support the early needs of the SEI and other space exploration endeavors. By advancing the existing technology, the DIPS program provides a highly innovative and leveraged technology for the cost effective use of radioisotopes in space. The Rocketdyne Division of Rockwell International is the DIPS program leader with Allied Signal Aerospace Company's Garrett Fluid Systems Division, Teledyne Energy Systems,

Thermoelectron Technologies Corporation, Physics International, and SCI Government Systems making up the other members of the DIPS team.

The DIPS is based on and utilizes the flight qualified, plutonium fueled GPHS modules currently being flown in the Galileo and Ulysses radioisotope thermoelectric generators (RTGs). The CBC power conversion technology has been demonstrated in prior programs such as DOE's Brayton Isotope Power System (BIPS) program and NASA's Brayton Rotating Unit (BRU) demonstration program, and is based on extensive experience with similar hardware in aircraft applications.

Current and nearterm component technology was chosen for DIPS to provide an opportunity for early deployment of this system with minimal development risk. As part of this technology evaluation, the technology bases were assessed for the following major DIPS assemblies:

- GPHS modules;
- HSU;
- TAC assembly;
- recuperator;
- radiator;
- ducting and bellows; and
- PP&C.

These evaluations are summarized in Table A-2 which shows that the 1133 °K (1579 °F) CBC DIPS has technology readiness levels ranging from 4 to 9, depending on the particular assembly. The technology base for each assembly is briefly discussed in the following sections.

GPHS Module State-of-the-Art

The technology base for the GPHS module is extensive and consists of the following items:

- materials, properties, and module performance characteristics have been well established in the government sponsored development program;

CLOSED BRAYTON CYCLE DYNAMIC ISOTOPE POWER SYSTEM TECHNOLOGY ROADMAP

- manufacturing and quality control programs have been demonstrated with production of flight qualified modules for the Galileo and Ulysses programs;
- safety issues have been resolved in conjunction with the Galileo and Ulysses flights (both used RTGs with GPHSs as the heat source); and
- both the Galileo and Ulysses spacecraft have been launched and are operational.

TABLE A-2. 1133 °K (1579 °F) CBC DIPS TECHNOLOGY ASSESSMENT

Subsystem	Technology Readiness Level	Comments
GPHS modules	9	Successfully flown on Galileo and Ulysses missions
HSU; RHRS HSU; MFI HSU; Gas Containment	4	Laboratory demonstration Subscale tests complete Inconel 617 boundary; well established data base
TAC assembly	5	Similar to BIPS and BRU turboalternator-compressor designs but with high temperature alternator electrical insulation and an all welded, fully inspectable gas containment boundary
Recuperator	6	Successful closed-loop experience - BRU and BIPS system tests
Radiator	6	Aluminum tube and fin radiator design similar to STS radiator technology and SSF radiators
Interconnect ducting	5	Conventional high-temperature materials; low-temperature dissimilar materials joint; conventional materials bellows design with fully inspectable welds
PP&C	5	Space Station Freedom Electrical Power Subsystem component (SSF-EPS) technology

HSU State-of-the-Art

The fuel handling canister, the RHRS heat pipes, and internal HSU vacuum liners are fabricated from Nb-1%Zr. Materials properties for Nb-1%Zr are well known and have been qualified in the SP-100 program. Silicide or titanium diboride emissivity/oxidation protective coatings are proposed for the canister and liner surfaces. These coatings are known to resist oxygen attack at temperatures exceeding the design temperatures for extended periods of time (years). The coating protection is only required in the Martian environment during transfer of

a fuel handling canister between HSUs and storage rack units (<1 hour per transfer). However, accelerated testing would be needed to establish the variables involved and confirm their application over the equivalent fifteen year lifetime. Long term stability of the coating in this application remains to be established.

Explosively bonded transition joints are used between the Nb-1%Zr and Inconel components for several joints within the HSU. Specifically, these joints are located in the HSU vacuum containment used for Mars applications and are not part of the HeXe pressure boundary. This is a well established fabrication technique. The joints are located in low temperature areas where intergranular effects are not expected to be an issue over the 15 year operational life. However, joint leak tightness and intergranular effects will need to be verified.

Lithium heat pipes, like those to be used for the RHRS, have a substantial data base as shown in Table A-3 (Ref. A-3), but the specific DIPS design is different than those comprising the data base. For this reason, a demonstration model was fabricated and tested at LANL, with successful results (Ref. A-4). At 1150 °K (1610 °F), the test heat pipe removed approximately 750 W of heat, which is in excess of the 710W target for the variable conductance heat pipe design. For the present DIPS RHRS design, the VCHP "on" temperature will be set at 1194 °K (1690 °F) by adjusting the neon gas inventory in the heat pipe.

The HSU uses multifoil insulation, not only to control heat losses from the HSU, but also to provide emergency cooling by melting and providing a direct heat path to space at a slightly higher than normal fuel cladding temperature. On the BIPS program, various combinations of multifoil insulation were subjected to subscale testing. The general conclusion that can be drawn from these tests is that the principle of progressive eutectic melting is valid. The tests also provide confidence that the meltdown characteristics of particular foil combinations can be accurately predicted.

TAC Assembly State-of-the-Art

The TAC design is similar to the 10 kWe BRU and 1.3 kWe mini-BRU units designed and tested by the Garrett Corporation in the 1970s.

The NASA BRU series of four units, with a flight configured recuperator, cooler, and ducting were tested for a total of 52,573 hours, most of which was at a turbine inlet temperature of 1144 °K (1599 °F). One of these units accumulated 41,000 hours, including a 13,600 hour continuous run. The BRU used pivoted pad bearings instead of foil bearings because foil bearing technology was not well developed at that time. Since then, the foil bearing has been used extensively in commercial aircraft auxiliary power units (APUs) for millions of hours and continuous improvements have been made to the bearing design. A summary of the APU foil gas bearing experience is given in Table A-4.

TABLE A-3. LITHIUM HEAT PIPE OPERATING EXPERIENCE

No.	Wall Material	Test Temperature (°K/°F)	Hours of Operation	Remarks
1	CVD-W	1000/1340	1000	
2	W-26Re	1000/1340	10000	
3	TZM	1500/2240	4600	Evaporator leak
4	TZM	1500/2240	10526	Weld leak
5	TZM	1500/2240	10400	Weld failure in end cap
6	TZM	1500/2240	9800	Weld failure in end cap
7	Nb-1Zr	1000/1340	132	
8	Nb-1Zr	1500/2240	9000	
9	Nb-1Zr deoxidized	1500/2240	1000	Grain growth, Zr loss, swelling
10	Nb-1Zr	1350/1970	2300	
11	Nb-1Zr	1100/1520	4300	
12	Nb-1Zr	1000/1340	3870	

TABLE A-4. APU FOIL GAS BEARING EXPERIENCE

	767/757	DC10	F-18	General Aviation	C5B
Systems in service	470	1,660	570	1,269	35
Total hours operating	6,735,800	59,073,400	406,180	3,200,500	42,000
Mean time between failures (MTBF), hours	57,100	61,700	45,135	35,170	N/A
Average number of start/stop cycles per unit	2,200	2,100	1,400	2,500	110
Annual bearing production rate	200	100	200	500	300

The mini-BRU was the turboalternator-compressor incorporated in the BIPS. After some initial problems with one of the foil bearings, design modifications were made and the unit was operated for 1000 hours in a relevant environment at a turbine inlet temperature of 1025 °K (1385 °F) with no further problems (i.e., TRL 6). The BRU and mini-BRU engines all used a Rice alternator. The DIPS TAC employs a two pole toothless (TPTL) permanent magnet generator (PMG). The use of Samarium-Cobalt permanent magnets for field excitation is a well established technology. Allied-Signal Samarium-Cobalt PMGs used in aircraft applications have in excess of 100,000 operating hours experience.

Recuperator State-of-the-Art

The applicable experience base for CBC recuperators includes the recuperators for the BRU series of power conversion units, and for BIPS. This experience base is summarized in Table A-5. As noted in the table, one of the BRU recuperators experienced a failure at 18,000 hours of operation. The nature of the failure was a leak between the core and the manifold ducting. Analysis of the cause of the failure attributed it to low-cycle fatigue due to deep thermal cycling. The problem was corrected by redesigning the internal support structure and shell, and using a welded and fully inspectable containment boundary for the recuperator shell. The BIPS recuperator used these improvements and was operated without incident. This

recuperator is now being refurbished for use on the 2 kWe Solar Dynamic Space Power System Ground Test Demonstration Project being performed by the Allied Signal/Rocketdyne team for NASA LeRC. These tests will include 1000 hours of steady-state operation plus startup/shutdown, and system thermal cycling tests.

The DIPS recuperator design is based not only on the five successfully recuperated CBC systems, but is also founded on heat transfer equipment developed by Allied Signal and used in thousands of commercial, refinery, and aircraft applications.

Radiator State-of-the-Art

The tube and fin radiator concept is a well established technology. Fabrication of the radiator assembly is accomplished using standard materials and fabrication practices. Tube and fin radiators are used in many commercial applications. The space shuttle uses a redundant pumped loop tube and fin radiator which has been in use for more than 10 years. On the Space Station Freedom (SSF) program, the main thermal bus uses a pumped loop tube and fin radiator concept. For the DIPS application, the fluid within the tube is the He/Xe working gas which is different from the preceding applications where the pumped fluid is a liquid. The radiator tube and fin design concept is the same, however, with the thermal hydraulic characteristics being slightly different. Thermal hydraulic tests will be required to verify heat transfer coefficients.

Optical Solar Reflectors (OSRs) have been used for thermal management of solar arrays and spacecraft on a variety of satellites such as Explorer, Intelsat, Solar Maximum Mission and Satcom. The OSRs are attached to the radiator fins with a silicone bond. Prototypic tests of bonding OSRs to aluminum fins were recently carried out at Rockwell, employing several different types of silicone bonding agents to demonstrate bond integrity and develop optimum application methods. Test results indicated that the bond is stable and shows no degradation in thermal cycling tests. The tests used a lap configuration and in all tests for bond strength, the bond was stronger than the tiles themselves.

TABLE A-5. APPLICABLE CBC RECUPERATOR EXPERIENCE

Unit Name of Designation	Power Level (kWe)	Design Feature	Operating Parameters	Test/Operational Hours	Key Test Results
BHXU (BRU)	1.0	Plate-fin plate-bar construction 347 SS	$T_{in}=1230$ °F $P_{in}=27$ psia $W=7.5$ lb/s	51,000	One failure at 18,000 h; unit repaired and test resumed
BHXUA (BRU)	1.0	Plate-fin double containment side plate Hastelloy-X	$T_{in}=1230$ °F $P_{in}=27$ psia $W=7.5$ lb/s He-Xe MW = 83	N/A	Not tested - 2 units delivered
BIPS	1.3	Plate-fin double containment side plate Hastelloy-X	$T_{in}=950$ °F $P_{in}=66.7$ psia $W=0.25$ lb/s He-Xe MW = 83	1,200	No failures

Ducting & Bellows State-of-the-Art

The DIPS system uses gas ducting components similar to those used and successfully demonstrated on the BRU and BIPS CBC systems. The ducting assembly consists of the metal ducting, bellows, and its multifoil insulation package. The BRU was tested in an environment simulating the pressures and temperatures of space. The BIPS was tested in space-vacuum conditions during a workhorse loop 1000 hour demonstration. In conjunction with the BIPS program, ORNL conducted a series of tests on BIPS bellows extending over several years at simulated space temperatures and pressures. The BIPS employed multifoil insulation which proved most effective for controlling thermal losses. For the DIPS ducting, Inconel 617 will be used for the hot leg ducting and aluminum or stainless steel will be used for the cold leg ducting. Dissimilar joint compatibility will be assessed for aluminum or stainless steel and Inconel 617.

PP&C State-of-the-Art

The DIPS PP&C system design is based on a reasonable electronics component evolution, from SSF component technologies and there are no significant technology issues associated with its development. However, PP&C mass will be critical item in the flight hardware design. It will be necessary to fabricate brassboard hardware for testing and evaluation purposes, but there is no need to initiate any advanced component development. Even though no space-based rotary alternator PP&C systems have been fabricated, most of the hardware elements have been or shortly will be operating in a relevant environment on other spacecraft or the SSF electrical power subsystem ground tests. The only new environmental factor is the radiation emitted by the DIPS HSUs. The DIPS radiation levels of 10^4 Rad (Si) are considered to be relatively low for electronic components. These radiation levels can be easily handled through proper component selection.

The electronics cooling radiator uses aluminum/ammonia heat pipes in an aluminum honeycomb/face sheet structure to reject the electronics waste heat (260 W thermal) to space. This technology has already been space qualified as indicated in Table A-6.

TABLE A-6. WATER AND AMMONIA HEAT PIPE EXPERIENCE

a) Ground and Shipboard Applications

Heat Pipe Material	Working Fluid	Application	No. Units Per System/Module	Units Built	Years in Service	Estimated Hours x 10 ⁶	Reported Failures
Cu/Cu	Water	Trident, SEM	108/3	7,000	14	458.65	0
Monel/Cu	Water	Mis. Spec.	1/1	300	10	8.74	0
SS/SS	Ammonia	Nassar Array	1000/1	1,200	16	467.39	0
Cu/Cu	Water	ALCM	12/3	12,000	8		0
SS-Cu/ SS-Cu	Methanol	MARM/ Missile	1/1	450	9		0
Cu/Cu	Water	Element G	1/1	397	2	2	0

b) Intended Applications - Shipboard, Avionics, and Space
(Life Test Completed)

Heat Pipe Material	Wick Material	Working Fluid	No. Units	Operating Temperature (F)	Total Hours	No. of Failures
Cu	Cu	Water	2	60 to 75	77,376	0
Cu	Monel	Water	1	70	48,406	0
Monel	Monel	Water	2	100 to 102	69,264	0
SS	SS	Ammonia	3	40 to 60	102,110	0
Al	Al	Ammonia	1	50	59,832	0
Al	Grooves	Ammonia	1	50	29,664	0
SS	Grooves	Ammonia	1	50	34,632	0

c) Space Applications

Heat Pipe Material	Working Fluid	Applications	No. Units Per System/Module	Units Built	Years in Service	Reported Failures
SS/SS	Ammonia	DSD, TWT baseplate	3/3	700	10.0	0
Al/Al	Ammonia	MSIII	19	22	0.5	0
Al/Al (Grooves)	Ammonia	Space telescope	3	3	0.5	0
Al/Al	Ammonia	Space sensor	1	2	0.2	0

MAJOR DEVELOPMENT TASKS

A 2.5 kWe CBC isotope power module is currently under development as part of the DIPS Demonstration Program which is sponsored by the U.S. Department of Energy (DOE) with support funding from NASA (Refs. A-1 to A-2). The development program defined in this roadmap is a continuation of the DIPS program. This development plan includes an initial component development and integrated ground system demonstration, a qualification program, and a flight program.

With the exception of the GPHS modules, the technology level of the DIPS components ranges from 4 to 6, and therefore development and demonstration testing is required. The development and testing tasks which are envisioned are briefly described in the following sections.

Task 1. Heat Source Unit Heat Exchanger (HSUHX) Development

Objectives: Develop a full scale flight HSUHX. Demonstrate adequate performance characteristics, means of protecting the unit from the effects of the Martian environment, long life at high temperatures, and structural integrity during a loss of coolant event.

Statement of Work: The work is divided into the following subtasks:

Subtask 1.1 Emissivity Coating Tests - Evaluate the emissivity and integrity of candidate coatings/surface treatments under the required thermal vacuum environments (including application techniques, surface preparations, and adherence) using subscale coupons. Select reference coatings (different coatings or surface treatments may be required due to the differing substrate materials) and apply to simulated canister, heat exchanger, and heat pipe wall surfaces. Conduct elevated temperature performance and thermal cycle tests to validate coupon emittance test results, and demonstrate adherence using prototypic configuration specimens.

Subtask 1.2 Multifoil Insulation Tests - Perform additional tests to verify the compatibility of candidate foil and oxide spacer materials under accelerated temperature

conditions. Clad foils which require bonding of two foil materials, are expected to yield a better defined melting point and a more rapid melt down, but they require development. Conduct subscale tests on bonded foil specimens to determine if they are practical to fabricate, perform as predicted, retain adequate bond strength, survive thermal cycling, and do not diffuse excessively. Results of the clad foil tests will determine whether clad or conventional layered foils will be selected as the reference DIPS configuration.

Perform subscale meltdown tests similar to those performed on the multifoil system developed for the BIPS program. These assemblies will have the same combination of foil, oxide spacer, number of foils, foil thickness, layer spacing, ratio of length to diameter, and hot side material as candidate HSU designs. Test assemblies by equilibrating at the design temperature and then heat at a rate corresponding to that seen if all cooling were lost. Verify by experiment and analysis safe fuel cladding temperatures following the loss of cooling event

Conduct thermal performance testing on prototypic sections of multifoil insulation to verify that the calculated losses from high heat loss components are within acceptable limits. Measure the heat input versus heat source temperature relationship of a full scale HSU in an inert gas environment to define storage and handling parameters.

Conduct stability tests on prototypic sections of MFI to verify stability under long term (up to one year), elevated temperature conditions in simulated environments.

Subtask 1.3 Heat Exchanger Coil Test - Fabricate a hydraulic model of one complete helical coil heat exchanger. Measure the pressure drop across the heat exchanger and compare to calculated values. Based on these experimental results, incorporate any necessary refinements required into the design.

Subtask 1.4 Overall Heat Exchanger Tests - Test one complete HSUHX powered by an electric heater for performance using an inert gas loop with the HSU under internal vacuum. Establish prototypic thermal and flow conditions, and conduct a performance test including thermal mapping under varying flow conditions. Vibration test the assembly and repeat the performance test to identify any degradation. Establish the condition of the HSU and verify that

the internals are undamaged. Run a final test in a vacuum chamber to verify that the meltable MFI performs as designed in the event of a loss of cooling. This test will render the HSUHX unsuitable for further testing.

Subtask 1.5 Electrical Heater Subassembly Tests - Test a complete set of electrical heater assemblies and their controls for performance, transient effects, operating environment, vibration, and shock effects. Perform endurance testing of the heaters to identify mean time between failure (MTBF) values for these major electrical components. Evaluate heater degradation, control functions, and monitoring functions during the endurance tests to establish instrument error bands to be used during the Integrated System Test Unit (ISTU) life test.

Task 2 - TAC Development

Objectives: Develop a full scale flight TAC. Demonstrate adequate steady state and transient performance characteristics, means of protecting the unit from the effects of the Martian environment, and long turbine life at high temperatures.

Statement of Work: The work is divided into the following subtasks:

Subtask 2.1 Compressor Tests - Operate a compressor stator/scroll assembly over its full range of mass flow to verify performance and map performance factors. In a separate test in a whirl pit, measure impeller growth at various speeds. Verify blade vibration mode shapes and frequencies by holographic testing.

Subtask 2.2 Turbine Tests - Operate a turbine/nozzle scroll assembly at a single design point speed and pressure ratio using air as the working gas to verify design performance. Evaluate test data and extend the results analytically to ensure a good match to the compressor at off design conditions. In a separate test, verify turbine wheel stress margins by measuring wheel growth at various speeds. Conduct performance testing in the modified compressor test rig and measure wheel growth in the whirl pit. Verify blade mode shapes and frequencies by holographic testing.

Subtask 2.3 Dynamic Simulator Tests - Determine turboalternator dynamic characteristics, critical speeds, and bearing losses using a rotor simulator with foil-gas bearings. Repeat these tests later using a functional alternator in an open-cycle TAC test. Determine alternator performance and dynamic characteristics. Conduct start-up and extended life tests.

Subtask 2.4 Alternator Tests - Conduct alternator stator and rotor tests with the rotor supported on conventional bearings. Measure the performance as an alternator and as a motor over a range of speeds, loads, and excitations. Conduct tests to determine generated power, electrical losses, thermal losses, wave shapes, starting torque and cooling required to maintain component temperatures.

Task 2.5 Alternator Insulation Tests - Develop a high temperature electrical insulation for the alternator stator. Perform voltage breakdown and lifetime tests of the electrical insulation to identify degradation mechanisms and lifetime limits as a function of component temperatures. Use these results to establish the cooling gas supply temperature limits in Subtask 2.4.

Task 2.6 Foil Bearing Tests - Design, fabricate and performance test the TAC foil bearing assemblies using a bearing rig test fixture to performance map each bearing configuration. Measurements should include torque versus speed, spring rate, load deflection, damping coefficient and starting torque versus load and acceleration. Perform shock and vibration testing for each bearing assembly.

Task 3. Recuperator Development

Objectives: Develop a prototype flight recuperator. Demonstrate adequate performance characteristics, means of protecting the unit from the effects of the Martian environment, and long life at high temperatures.

Statement of Work: The work is divided into the following subtasks:

Subtask 3.1 Recuperator Leakage Pressurize the recuperator core assembly with hot gas and thermally cycle it to verify its structural integrity. Measure leakage across the core and critical dimensions at temperature extremes.

Subtask 3.2 Heat Transfer Performance Conduct hot-gas heat transfer tests on a recuperator core section to verify performance. Measure pressure drops through the recuperator core section versus flow rate and inlet temperatures for He-Xe gas mixtures.

Task 4. Radiator Assembly Development

Objectives: Develop a prototypic gas tube and fin radiator assembly. Demonstrate adequate structural and thermal performance characteristics, and a means of protecting the unit from the effects of the Lunar and Martian environments, over its 15 year design lifetime.

Statement of Work: Performance test a module consisting of an aluminum gas tube and fin radiator assembly and associated headers. Verify performance of the radiator section under design point and extremes of temperature and radiating surface contamination conditions. Measure pressure drop, flow distribution, and heat transfer to determine radiator performance.

Conduct baseline performance tests in a vacuum chamber, with the assembly at temperature and radiating to a chamber cold wall. Perform random vibration tests of the assembly to determine its response and identify potential structural integrity problems. Repeat the performance testing to verify structural integrity.

Develop the OSR tile application process and establish the required bond strength. Demonstrate the OSR lifetime performance. Perform dust tests of the radiating surface effectiveness to simulate the lunar and Martian environmental effects on radiator performance.

Task 5. Ducting and Bellows Development

Objectives: Develop prototypic hardware for the interconnect gas ducting and bellows. Demonstrate adequate performance of the ducting.

Statement of Work: Design and fabricate prototypic interconnect ducting and bellows. As required, conduct static and dynamic structural verification testing on elbow ducting, branch

connections, straight sections, bellows, all joints, and heat exchanger inlet/outlet components at room temperature and elevated temperatures. Perform deep thermal cycling tests on all joints and bellows to establish thermal cyclic life. Verify performance using pressure drop and flow distribution tests.

Task 6. PP&C Development

Objectives: Develop the necessary PP&C hardware and software to control the DIPS operation and process alternator output power. Demonstrate adequate steady state and transient voltage control at rated load conditions. Demonstrate lifetime, reliability and compatibility with the environment (including launch and operating environments). Develop and demonstrate the software capable of providing power system control under nominal, transient operations and during simulated failure modes.

Statement of Work: The work is divided into the following subtasks:

Subtask 6.1 Electrical Component Development - Build brassboard units to demonstrate and check functional performance of the individual component circuit designs. Incorporate design modifications and improvements, as necessary, into the brassboard units. Verify functional performance within the constraints of the actual component configuration. Fabricate prototype units and conduct a series of performance tests using simulated input and output loads. Conduct controller tests and validate the operating system software. Conduct the following other tests:

- start up, steady state and transient control simulation;
- failure simulation for detection and automatic switching to redundant control channel;
- effects of temperature extremes and thermal shock;
- effects of atmosphere;
- current limit protection demonstration;
- cold plate heat loads;

- Master/slave controller architecture demonstration (for integrated multiple unit power supplies); and
- EMI generation and susceptibility.

The prototype cable harnesses and parasitic load radiator will be checked out with the PP&C components during the ISTU calibration and set-up tests.

Subtask 6.2 Software Development - Develop the DIPS controller software. Check out the software in conjunction with tests of the controller, using simulated inputs and outputs. Integrate and checkout the software as part of the controller tests in Subtask 6.1.

Task 7. Integrated System Test Unit (ISTU) Development and Test

Objectives: Develop and test a full scale ISTU. Demonstrate adequate steady state and transient performance characteristics, long life at high temperatures, and suitable performance during failure modes. The ISTU shall be instrumented and calibrated during initial tests to validate the performance of the individual component designs.

Statement of Work: Assemble a complete power conversion unit consisting of two simulated HSU heat exchanges and one prototypic HSU, TAC, recuperator, interconnecting ducting, controls and instrumentation. Conduct tests in air using fibrous insulation on the ISTU loop with an electrical heat source, simulated user loads, and parasitic load resistors. Install a vacuum system to maintain the prototypic HSU containment vessel under internal vacuum. Demonstrate start-up, shutdown, and alternator design speed control under nominal operating conditions. Verify proper interface with the DIPS controller under conditions of varying power demand and simulated faulted conditions. Perform the following tests:

- time to start up from cold condition and motor KVA, inverter ramp rate;
- startup and battery recharge time;
- thermal balance;
- electrical power generating capability;
- steady state and dynamic stability;
- shutdown and start-up under simulated faulted conditions; and

- life test.

The work is divided into the following subtasks:

Task 7.1 ISTU Calibration and Set-up Tests - Pressure and leak test the ISTU. Fill the gas system with the He-Xe working fluid. Perform a complete electrical check-out of the unit including TAC shim and calibration tests and adjustments. Verify performance of thermal insulation.

Conduct a preliminary performance test sequence to demonstrate technical capabilities and measure critical unit performance parameters. Integrate acceptance level and design margin tests, up to qualification levels, into the initial test sequence to validate the individual component designs. Disassemble and inspect the individual components in the ISTU for wear and degradation effect and update component designs for the qualification and flight units as necessary.

Task 7.2 ISTU Life Test - Refurbish the ISTU components after completion of the performance, acceptance, and margin tests and place the unit on a multiyear life test. Refurbishment of the unit should include:

- replace or repair components to provide a prototypic hermetically-sealed gas containment boundary for the ISTU; and
- add special instrumentation required for the life test phase

Install prototypic instrumentation to provide a comprehensive diagnosis of the "health" of the ISTU and to monitor for degradation of major assemblies and individual components. Operate the ISTU at its nominal operating point, with expected ISTU variations in power output and environment.

Disassemble and inspect the ISTU at the end of the life test. Determine specific areas to be examined by an analysis of the health monitoring data and from the reliability analysis predictions. Typical characteristics to be determined by the examination should include, but are not limited to, bearing wear, welds and bellows wall metallurgical examinations, electrically controller setpoint drift, HSU MFI condition, and turbine blade erosion.

Task 8. Qualification Program Testing

Objectives: Design, fabricate, and test the flight system. Develop a low risk qualification program. Verify adequate performance and life for the entire system under flight qualification conditions.

Statement of Work: Perform a comprehensive performance and dynamic testing program of assemblies and the complete system to provide a formal demonstration that the DIPS will perform as designed after being subjected to simulated launch conditions.

Start with qualification of assemblies, as seen in Figure A-10. Fabricate qualified production items and assemble these parts into the QU. Qualify the QU by the rules for space vehicle qualification.

The work is divided into the following subtasks:

Subtask 8.1 Component Qualification Testing - Conduct performance testing at the component and assembly level to verify that each item performs as designed. Perform dynamic testing per MIL-STD-1540B to verify capability of the DIPS system to withstand launch loads, including acoustic, pyroshock and vibrational. The performance and dynamic qualification test sequence for components and assemblies is shown in the matrix of Figure A-11.

Subtask 8.2 Qualification Unit Testing. Fabricate, assemble, checkout, and test the QU. Use the same test facilities for component and assembly qualification testing as were used for the assembly level testing of the ISTU. The corresponding qualification test sequence for the QU is shown in Figure A-12.

Subtask 8.3 Qualification Life Testing (Optional) - Partially disassemble, examine, and refurbish the QU as required and modify for endurance testing as described for the ISTU. Life test the unit for 1.5 years (optional).

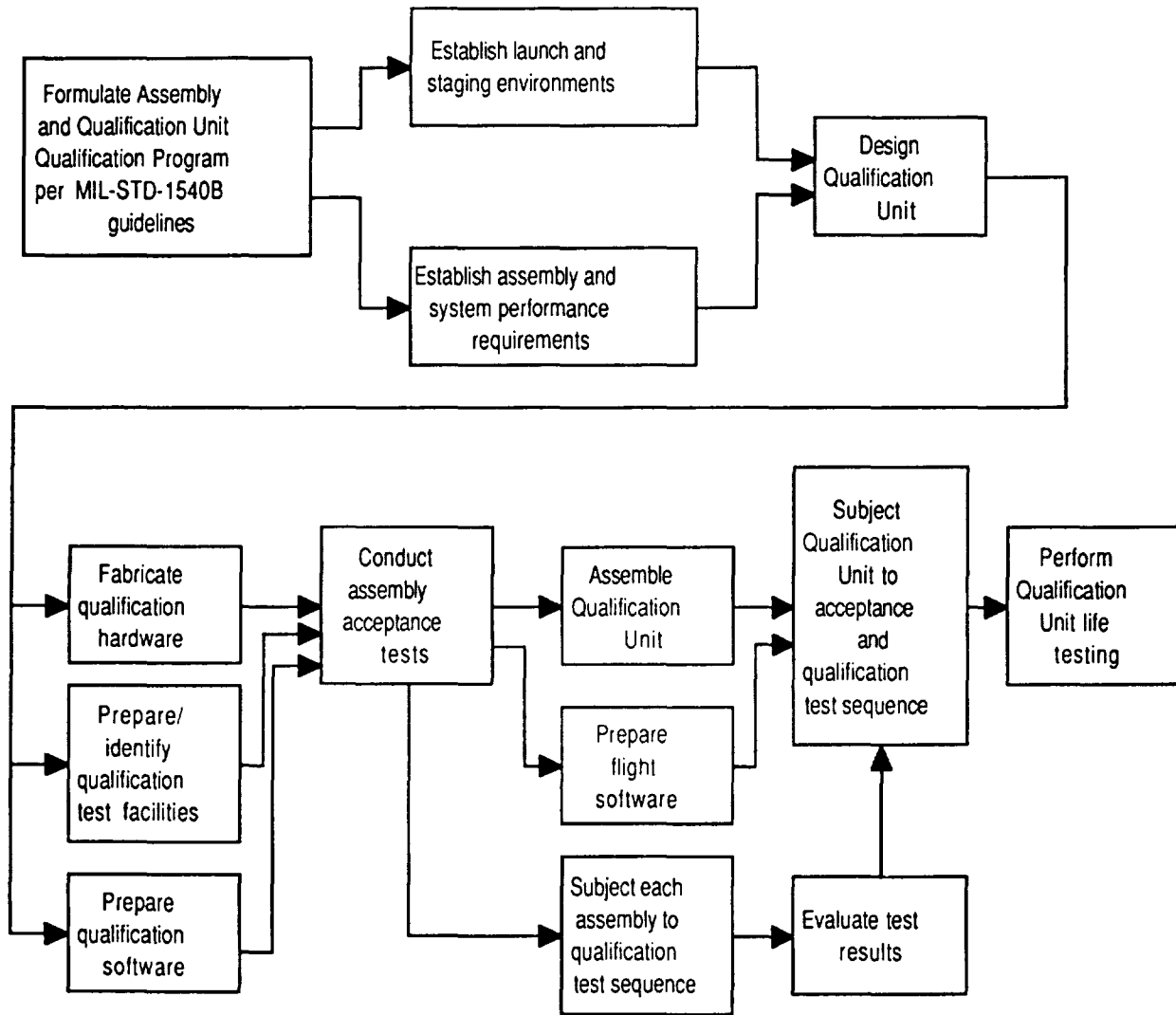

Figure A-10. DIPS qualification program.

Component or Subassembly	Functional (1)	Leak	Pyroshock	Functional (2)	Random Vibration	Functional (1)	Leak	Acceleration	Functional (1)	Thermal Cycling	Functional (2)	Thermal Vacuum	Functional (2)	Pressure	Leak	EMC	Life	Functional (1)
HSU	X	X			X	X	X		X			X	X	X	X		X	X
TAC and recuperator	X	X			X	X			X			X	X	X	X	X	X	X
Radiator and manifold	X	X			X	X	X		X			X	X	X	X		X	X
Electronics radiator	X	X			X	X	X		X			X	X	X	X		X	X
Parasitic load radiator	X				X	X			X			X	X			X	X	X
PP&C	X		X	X	X	X			X	X	X	X	X			X	X	X
Structure	X		X		X	X		X	X			X	X				X	X

Figure A-11. Assembly qualification test matrix.

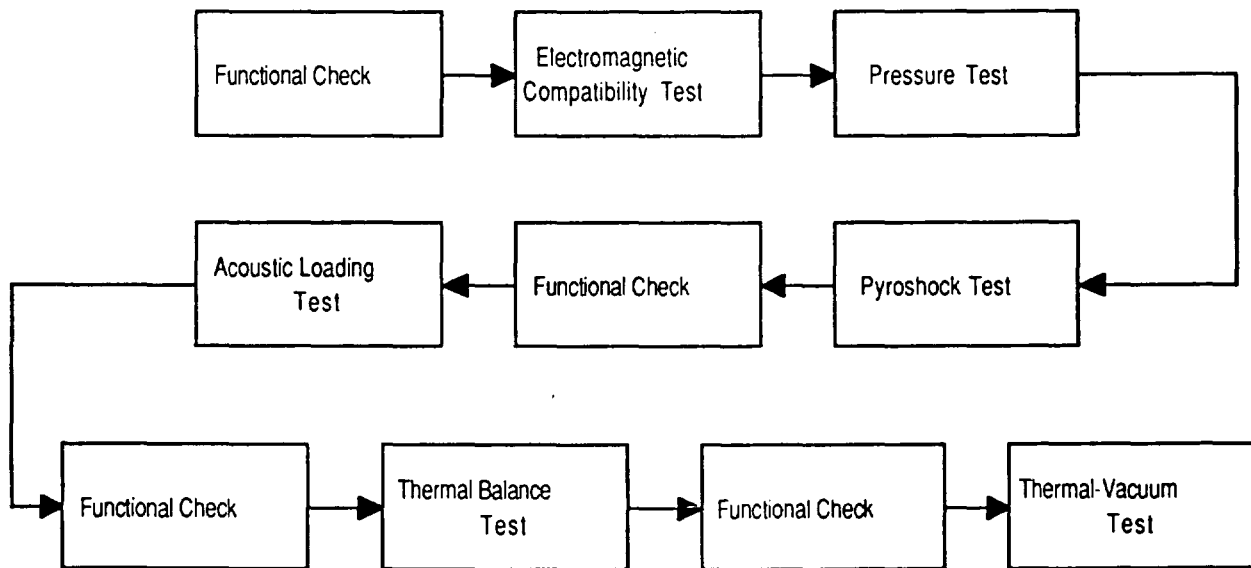

Figure A-12. QU test sequence (per MIL-STD-1540B).

Task 9. Flight Unit (FU) System Program

Objectives: Fabricate two flight systems, perform a flight safety program, and acceptance test the FUs to demonstrate required performance. Deliver the flight systems and provide integration support for the FU with the payload and the launch vehicle.

Statement of Work: Fabricate, acceptance test, and assemble parts to produce two DIPS flight systems. Subject both systems to acceptance testing per MIL-STD-1540B guidelines before shipment to the launch site. Use the same test facilities (vacuum chamber, vibration, acoustic) that were used for the qualification program for flight system acceptance testing. Perform safety studies and complete safety reports necessary to obtain launch approval. Provide launch support for the DIPS flight unit for integration with the payload and launch systems.

The work is divided into the following subtasks:

Subtask 9.1 Flight Component Fabrication. - Design, fabricate, inspect, and assemble the components and subassemblies required for the QU and FUs, including all spare parts and GSE as required.

Subtask 9.2 FU Assembly, Test, and Payload Integration - Assemble and inspect the two FUs. Acceptance test both FUs and ship to the launch site. Provide technical support for FU integration with the payload, launch vehicle, and launch support facilities.

Subtask 9.3 Flight Safety Program - Develop a flight safety program plan to support the safety studies and tests required to obtain launch approval. Prepare the safety analysis reports (SARs), and all supporting analyses and documents to assure launch approval.

Subtask 9.4 FU Launch Support - Provide launch support for the integrated FU/payload and launch vehicle systems. This includes FU monitoring during ascent, payload deployment, and FU startup on station.

DEVELOPMENT SCHEDULE

Figure A-13 presents the 2.5 kWe DIPS development schedule. The DIPS program has completed a 1 year conceptual design task. The preliminary design would be completed in the next two years. Concurrent component development of the heat source unit, power conversion unit (TAC, recuperator, and ducting), radiator assembly and PPCA is completed in 2.75 years. Detail design work is subsequently completed after 3.5 years.

Fabrication of components for ground testing for the ISTU starts with procurement of long lead materials and equipment in the second year of the program. This leads to assembly of the ISTU in the first half of the third year.

The ISTU will simulate the performance of a flight system but will have features such as additional instrumentation and readily accessible components to expedite gathering of engineering data and to permit modification of components. It will be performance tested in air under normal and off-normal design conditions. After this phase of testing, it will be partially disassembled, examined, refurbished as necessary, and put on life test, nominally for 1.5 yrs.

The qualification phase includes design, fabrication, assembly, and qualification testing of individual components for three units, and a complete DIPS system qualification test. The redesign effort will be limited to minor modifications to the preliminary DIPS design.

The flight phase of the program includes assembly, and acceptance testing of two flight units and the associated safety analysis support for launch approval. Launch support activities would include the flight unit-payload and launch vehicle integration tasks as well as post launch support activities.

REFERENCES

- A-1 Johnson, R.A.; Hunt, M.E.; Pepping, R.E.; and Mason, L.S.: A Dynamic Isotope Power System Portable Generator for the Moon or Mars. 26th IECEC proceedings, Vol. 2, August 1991, p. 210.
- A-2 Johnson, R.A.; Stadnik, A.G.; and Williams, R.: Compact, Long-Lived Dynamic Isotope Power Systems for the Exploration of Space.
- A-3 Heat Pipe Design Handbook, June 1979.
- A-4. Woldshun, K.: Rocketdyne Emergency Cooling Heat Pipe Design Summary. LANL draft report, 6 March 1987.

APPENDIX B - PEM RFC TECHNOLOGY ROADMAP

INTRODUCTION

This is a family of power systems based on common technology for use with portable or mobile power systems. Mobile RFC power systems are either incorporated into vehicles or are attached to vehicles as part of a separate power cart. These systems range in nominal power level from 3 to 22 kWe. These vehicles include the payload unloader (3 kWe normal [n]/10 kWe peak [p]), pressurized manned rover (7 kWe onboard, 12 kWe with power cart), regolith hauler (3 [n]/15 [p] kWe), and mining excavator (22 [n]/40 [p] kWe). Mobile Mars power systems will be similar to lunar systems except for the radiator size.

CONCEPT DESCRIPTION

The RFC system converts electrical energy into chemical energy and stores the energy for future use. An RFC is an energy storage device similar to a battery. The RFC system can be divided into six major subsystems for development purposes: (1) a fuel cell stack, which electrochemically converts hydrogen and oxygen into electricity; (2) an electrolyzer cell stack, which electrolyzes the fuel cell product water into gaseous hydrogen and oxygen reactants using externally provided power; (3) water management which removes moisture from the electrolysis cell product gases and humidifies fuel cell reactants to maintain proper cell membrane moisture content; (4) thermal management, which removes waste heat from the system, maintains the proper membrane temperature, prevents boiling or freezing in critical flow paths; (5) reactant storage (hydrogen, oxygen, and water); and (6) power processing and control (PP&C). The PP&C must be designed to allow for recharging from the base power system (either photovoltaic arrays or nuclear reactor) or from a portable Dynamic Isotope System (DIPS) cart.

A simplified schematic of a potential RFC system is shown in Figure B-1 (Ref. B-13). Figure B-1 does not show the details of the design such as electrical controls, fluid controls, trace heating, phase separation, gas humidification, gas drying, or redundant components. These

items will be discussed in detail in the following sections.

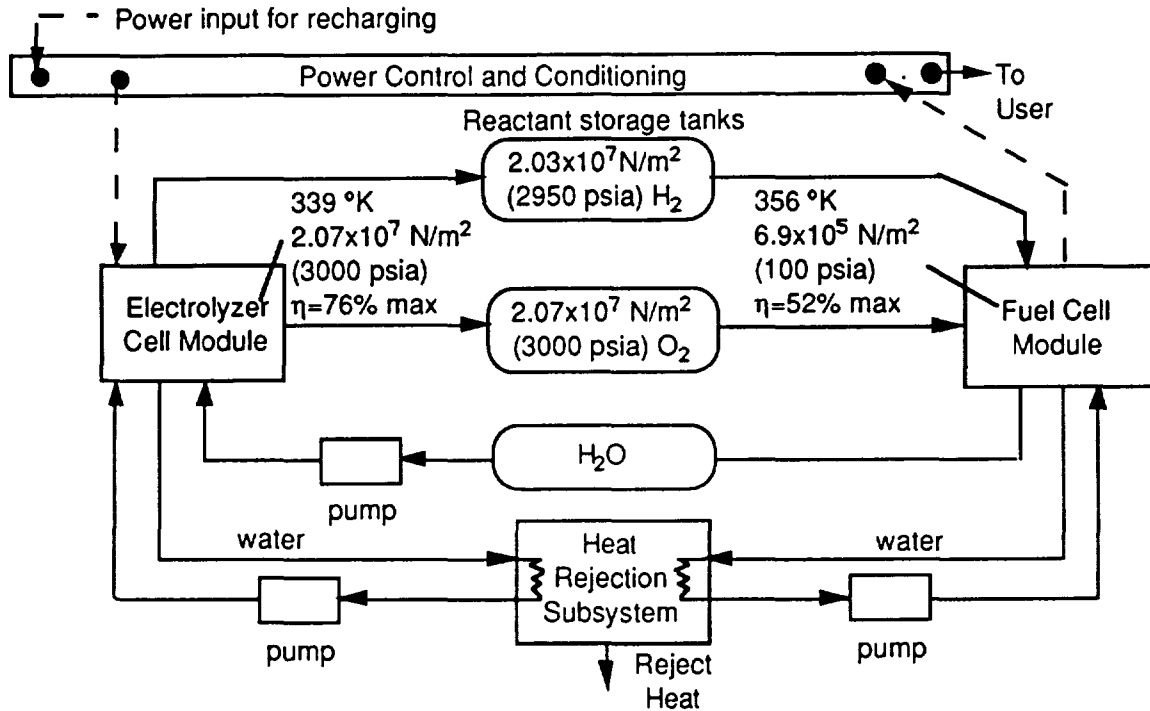

Note: Necessary electrical and fluid controls, and redundant components not shown. Typical operating conditions and performance shown.

Figure B-1. PEM RFC power system schematic.

In the baseline RFC concept, high pressure oxygen and hydrogen gas were assumed for gaseous reactant storage tanks of relatively low volume. High pressure gas storage reduces the size and mass of the storage tanks. Cryogenic storage of oxygen and hydrogen may be desirable for large fixed systems, but will not be addressed in this roadmap. The complexity and power required for a liquefier is probably not warranted for a mobile system.

Two types of fuel and electrolysis cell technologies are available: alkaline and PEM. Proton Exchanger Membrane (PEM) fuel cells and electrolysis cells were selected for this study since these technologies were shown to be the preferred RFC approach for long life SEI applications in a recent LANL study done for NASA (Ref. B-1). The basic design and operation of the PEM RFC system are described in the following paragraphs.

Fuel Cell Description

Fuel cells operate by separation of two electrocatalytic conversion reactions with an ionic conductor, as seen in Figure B-2 (Ref. B-2). Charge moves through electron conductors connecting the two electrocatalytic zones, where electron transfer results in chemical reactions. Ionic transport through the separator completes the process.

The PEM fuel cell incorporates an ion exchange membrane, typically a polyperfluorosulfonic (PFSA) acid sheet, as the ionic conductor. This component sustains transport of hydrated hydrogen ions, protons (H^+), associated with water. Protons are generated at the porous anode electrocatalytic layer and transport through the ionic conductor to the cathode electrocatalytic layer. At the cathode, protons react with oxygen to form water. Product water exhausts from the cathode compartment.

Hydrogen and oxygen gases are stored at 2.07×10^7 N/m² (3,000 psia) (Ref. B-3) for use in the fuel cell. The gases are regulated down to fuel cell operating conditions (4.14×10^5 to 6.9×10^5 N/m² or 60 to 100 psia). Oxygen is regulated to a few psi higher than hydrogen (for safety reasons) to insure that only oxygen is entrained in the product water. The reactant gases must be humidified prior to reacting in the stack. Humidification will be discussed in the water management section.

The hydrogen and oxygen gases are combined in the fuel cell to generate electricity and water. The product water is discharged into the cooling water loop. As the cooling water accumulator approaches the filled condition, the product water drain valve opens to allow water to flow to the storage subsystem.

The product water which leaves the fuel cell stack will be saturated with oxygen. This oxygen must be removed prior to entering the water storage tank. An approach for doing this has been demonstrated (external to the fuel cell) by Hamilton Standard, as seen in Figure B-3 (Ref. B-3). Water passes through an ion exchange membrane from the product water stream to humidify the dry hydrogen gas. Hydrogen diffuses from the hydrogen stream through the membrane to the water stream and combine with the oxygen to form water. Excess hydrogen is

REGENERATIVE FUEL CELL POWER SYSTEM TECHNOLOGY ROADMAP

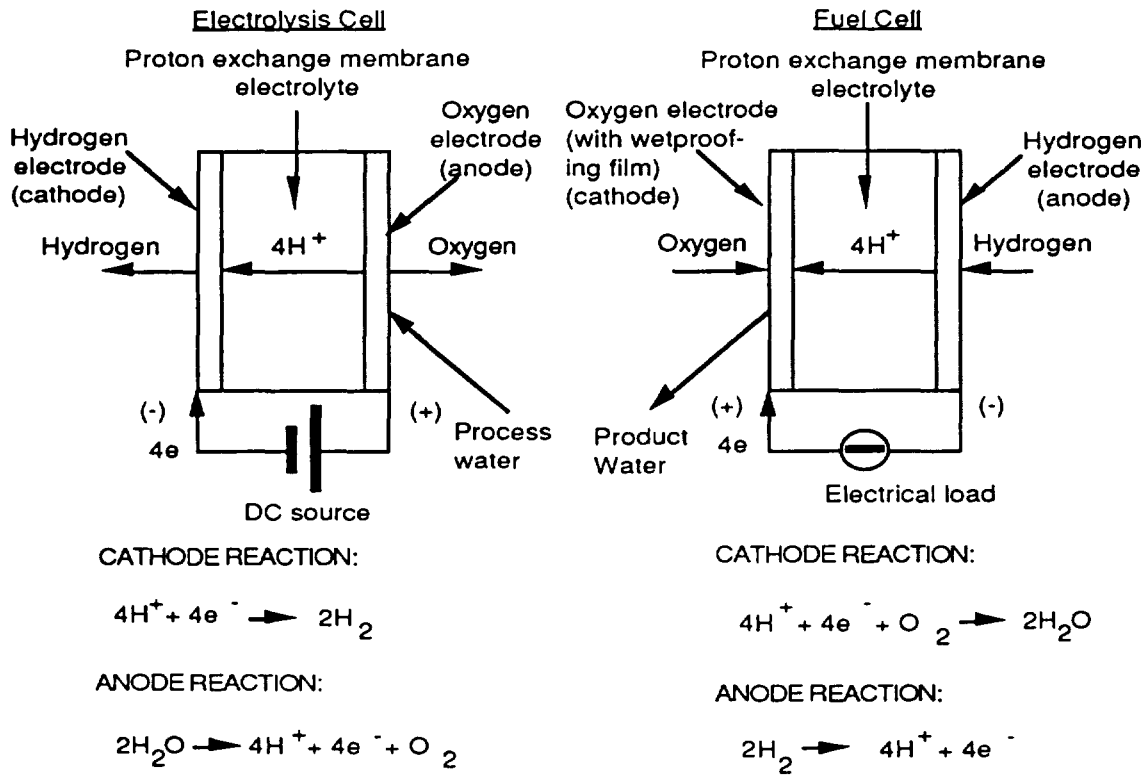

Figure B-2. Acid PEM electrochemical cell reactions.

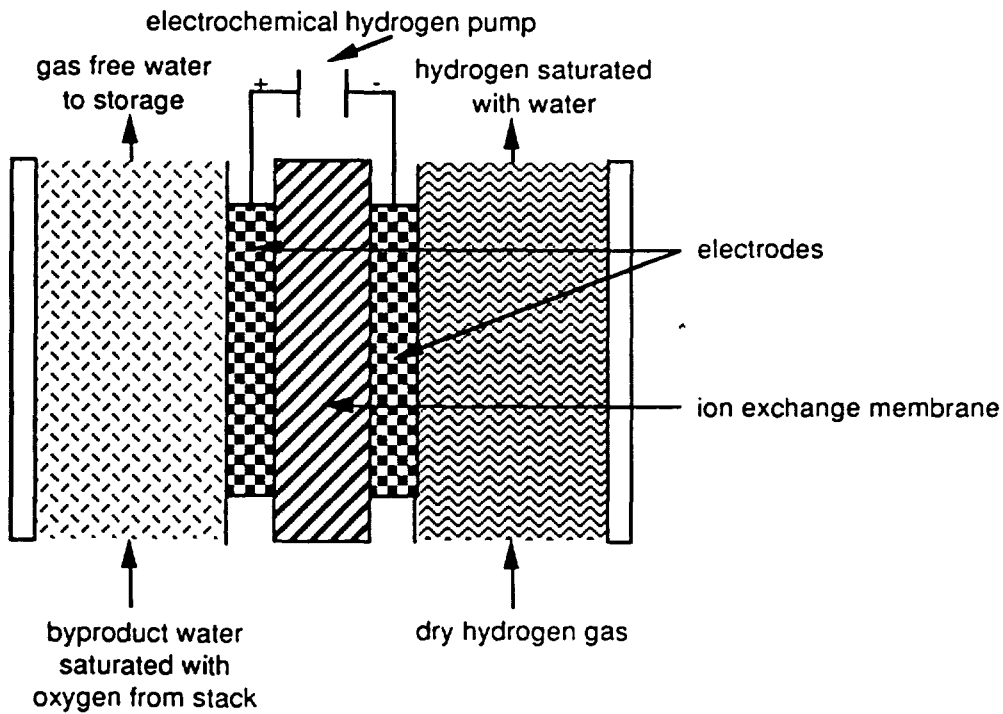

Figure B-3. Fuel cell product water deoxygenator.

returned to the hydrogen stream using an electrochemical hydrogen pump. Thus, only gas free water returns to the storage tank.

The fuel cell design options have to do with the type of membrane. Table B-1 (Ref. B-3) compares the fuel cell design options on a power density basis. The values in this table assume a system with 25 kWe net output continuously, 55% fuel cell thermal efficiency (based on 1.48 VDC) for 20,000 hours, and a design that is thermal vacuum compatible.

TABLE B-1. FUEL CELL DESIGN OPTION POWER DENSITY COMPARISON

Fuel Cell Subsystem Description	Nafion 120 Membrane (current)	Nafion 125/117 Membrane (advanced)	Dow Membrane (advanced)
	W/kg	W/kg	W/kg
"SOA Design" with Porous Hydrophillic Phase Separators (Space Station design)	103	184	307

Electrolyzer Cell Stack Description

The PEM electrolyzer has the same type of ion exchange membrane as the PEM fuel cell to transfer H+ protons from the anode to cathode as was shown on the left of Figure B-2. Liquid water is pumped from the water storage tank by the water feed pump into the water recirculation loop, as was seen in Figure B-1. The water recirculation loop feeds the water into the cell stack on the anode side of each cell. Some water passes across the proton exchange membrane (PEM) forming a second water loop. Excess anode water loop flow is used to remove waste heat from the stack. Separators in the cell stack separate the hydrogen and oxygen gases from the liquid water streams, as seen in Figure B-4 (Ref. B-3). The separated gases (saturated with water vapor) are fed into regenerative dryers or are fed directly to the reactant storage tanks.

a) HYDROPHOBIC OXYGEN PHASE SEPARATOR

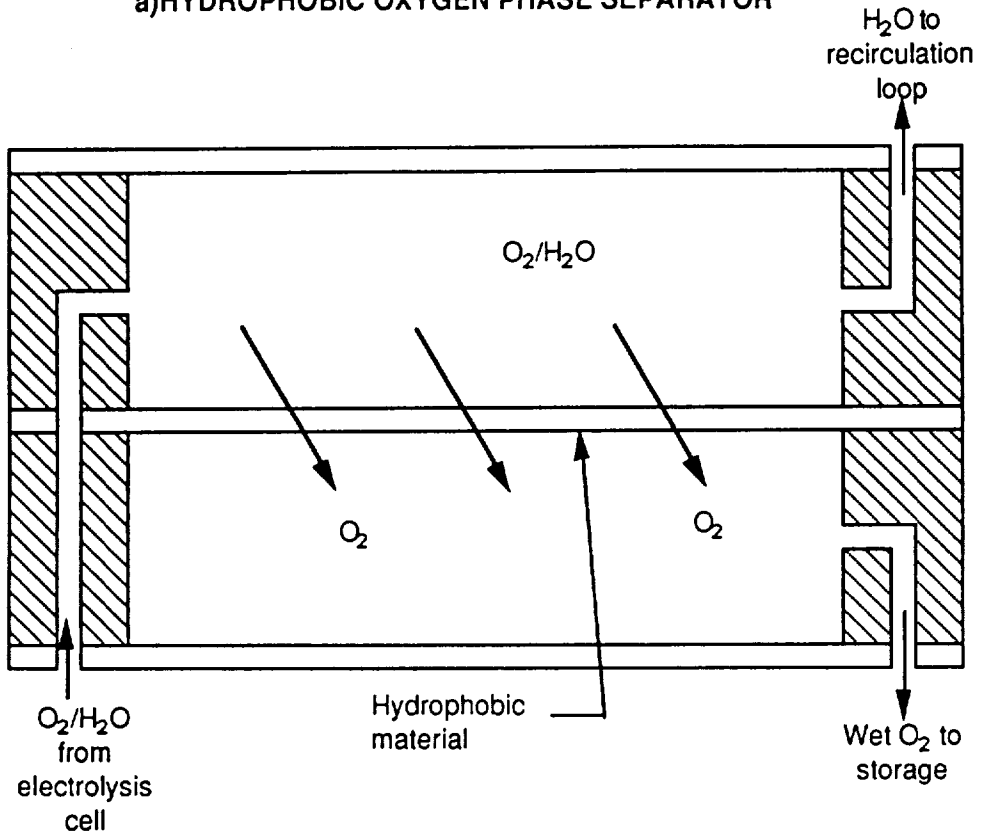

b) HYDROPHILIC/ELECTROCHEMICAL HYDROGEN PHASE SEPARATOR

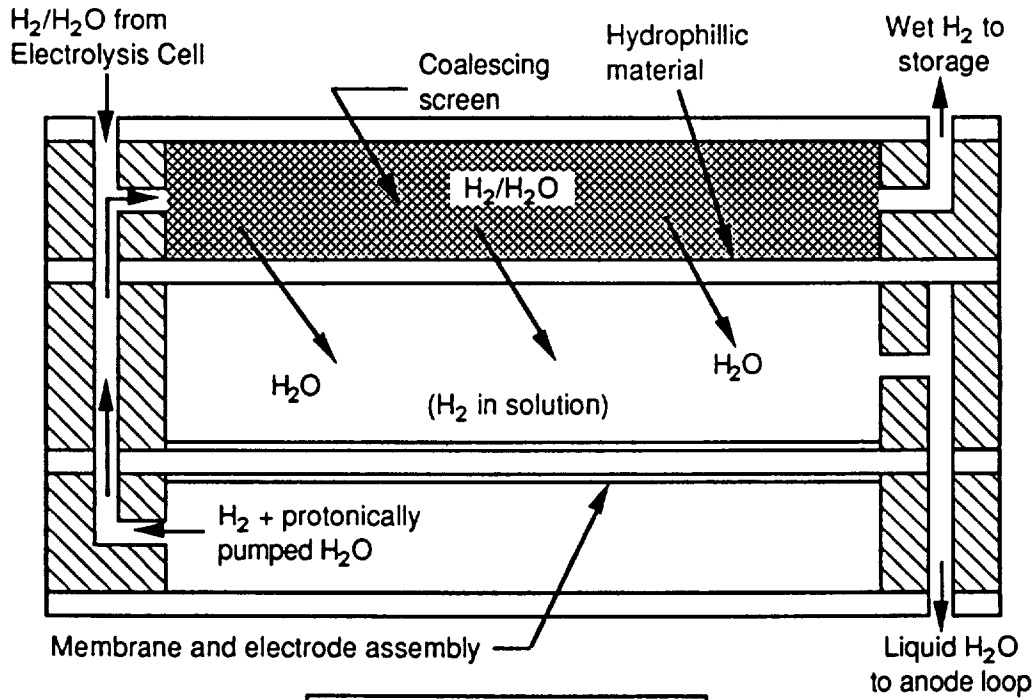

Note: Dimensions not to scale.

Figure B-4. Oxygen and hydrogen phase separators in electrolyzer stack.

Various electrolyzer options were identified involving different cell spacings and different membranes. The estimated power densities for each design is shown in Table B-2 (Ref. B-3). Table B-2 values assume a system with 70% electrolyzer thermal efficiency for 20,000 hours, 2.07×10^7 N/m² (3,000 psia) gas generation pressure, thermal vacuum compatible design, and 13 kg/h of water electrolyzed. Only the Nafion 120 membrane has been life tested at 2.07×10^7 N/m² (3,000 psia).

TABLE B-2. ELECTROLYZER DESIGN OPTION POWER DENSITY COMPARISON

Electrolyzer Subsystem Description	Nafion 120 Membrane (current)	Nafion 125/117 Membrane (advanced)	Dow Membrane (advanced)
	W/kg	W/kg	W/kg
"SOA Design" with Static Separators	258	327	377
"Advanced Design" with Static Separators	347	392	414

The state-of-the-art (SOA) electrolyzer design utilizes the cell design which is used for U.S. and Royal Navy submarines. This cell design allows for 2.75 cells per centimeter (0.36 cm thick). The U.S. Navy utilizes a 2.07×10^7 N/m² (3,000 psi) stack while the Royal Navy uses a 1.03×10^6 N/m² (150 psi) stack design.

The "advanced" (Ref. B-3) electrolyzer design utilized a cell design of 12 cells per centimeter (0.083 cm thick). This cell was incorporated into a 120 cell stack for testing by the U.S. Navy as a low mass oxygen generator prototype. The advanced cell stack was designed for a maximum pressure of 2.76×10^6 N/m² (400 psi) without a housing. SOA cell stacks use a cell size of about 214 cm² (16.5 cm circular cell). This appears to be the optimum efficiency cell size for several 2.07×10^7 N/m² (3,000 psia) electrolyzer applications (Ref. B-4).

Thermal Management Subsystem Description

The thermal management subsystem provides temperature control, heat transport, and heat rejection functions. Pumped water and coolant loops provide the heat transport function,

as seen in Figure B-5. A radiator is required to remove waste heat from the RFC system. There are inefficiencies in both the fuel cell stack and electrolysis cell stack which create waste heat. Membrane temperature must be controlled to prevent failures and meet life requirements. Water cools the stacks by collecting the waste heat and then transports the heat to one or more heat exchangers (one for electrolyzer and one for the fuel cell, or possibly a combined heat exchanger). These heat exchangers then transfer heat to the radiator coolant loop. Waste heat from the fuel cell may also be utilized to keep the electrolyzer from getting too cold.

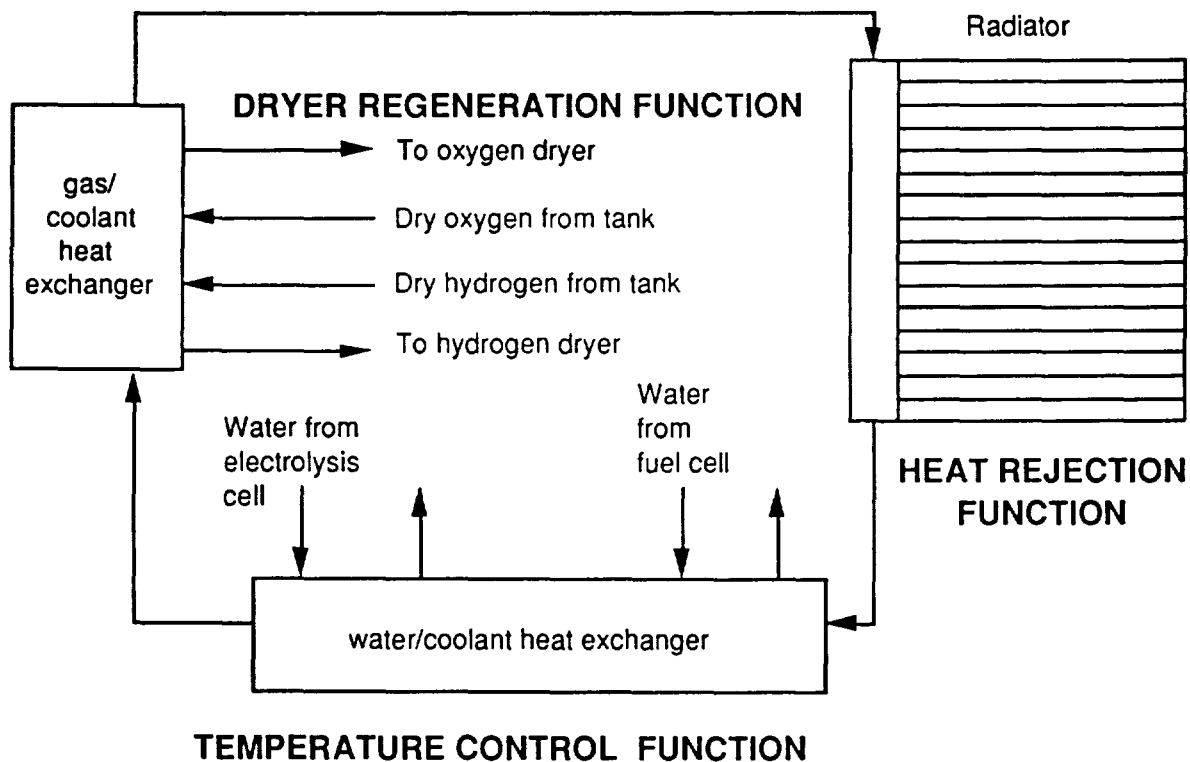

Figure B-5. Thermal management subsystem.

The heat rejection assembly provides a means for rejection of waste heat to the environment. Radiators for heat rejection are in some cases a major component of the power system mass. Radiators can also be quite large due to the low operating temperature.

Various options are available for the radiator design. Pumped loop radiators have been

used successfully for the space shuttle and will be used for Space Station Freedom (SSF). This type of radiator is best applied to missions with limited duration or to systems which are serviceable. Pumped loop radiators are less massive than state-of-the-art heat pipe radiator designs. Heat pipes offer the advantage of improved reliability and a graceful failure mode. A recent Rocketdyne study has shown that advanced carbon-carbon (C-C) heat pipe radiators can be designed which are competitive in mass to pumped loop radiators. Thus, a heat pipe radiator was tentatively selected as the baseline design.

The baseline heat rejection assemblies for RFCs utilize lightweight, passive, reliable, heat pipe radiators that are sufficiently versatile to allow integration into a variety of configurations. The individual heat pipes operate independent from one another and thus the failure of a heat pipe will not result in failure of the complete radiator. The rectangular radiator heat pipe panel is attached to the coolant manifold. The cooling loop transfers heat to the heat pipes in the manifold heat exchanger. The heat pipe working fluid evaporates and travels to the top end of the heat pipes. The evaporated fluid is then condensed in the cooler section of the heat pipe. Both gravity and a small wick or grooves allow the liquid to return to the evaporator. A wick or groove is not absolutely necessary for vertically oriented radiators (due to gravity return) but is recommended to insure good control of the fluid transport. The heat pipes may be either carbon-carbon tubes with metal liners (Monel for water or aluminum for ammonia working fluids) or metal heat pipes.

Condensation and freezing of the water in critical locations must be prevented by maintaining fluid temperatures within limits. Thermal control of the lines and tanks may be accomplished by insulation, trace heating, insulation and trace heating, or convective heating/cooling using the radiator coolant. Composite tanks need to be kept above 219 °K to prevent tank failure. The composite tank liner will begin to separate from the overwrap at this temperature and buckling will occur. It may also be desirable to prevent the water vapor in the gases from freezing in the tanks. Fluid lines may also require thermal control to prevent water freezing and clogging of lines (especially in the pressure regulators).

Water Management Subsystem Description

Water management includes moisture control of the fuel cell membrane and the removal of moisture from electrolysis module product gases.

The moisture content of the fuel cell stack membranes must be carefully controlled to prevent dehydration and reduced life. The reactant gases must be humidified to maintain the proper membrane moisture content.

The traditional humidification approach for PEM fuel cells is shown in Figure B-6 (Ref. B-4). The humidifier automatically presaturates the incoming hydrogen and oxygen reactants to a dew point equal to the cell operating temperature. This latter approach was used in the Hamilton Standard SPE[®] fuel cell. The problem with this approach is that the product water going to the storage tank is saturated with oxygen. If the oxygen is not removed from the water, then the gas will accumulate in the water tank and have to be vented off (undesirable loss of reactant).

Another gas humidification approach, which is more appropriate for space systems, was shown in Figure B-4 (Ref. B-3). This approach also removes the oxygen gas from the product water and there is no gas buildup in the tank. This concept converts the oxygen to water by diffusion of hydrogen across the membrane. A hydrogen electrochemical pump keeps hydrogen from evolving in the water. Excess hydrogen is pumped back to the hydrogen side of the device. Although not shown in Figure 4, the oxygen reactant is also humidified in this same device.

If regenerative gas dryers are used in the system, then the gas from the tanks will be partially rehumidified during regeneration of the dryers as is seen in Figure B-7 (Ref. B-5; only the oxygen humidification is shown). Heat must be added to the cool dry gases in order to vaporize the water in the dryers. The purpose of this process is primarily to recover water from the gas dryers. Most of the gas humidification will be done using a humidifier such as was shown in Figure B-4.

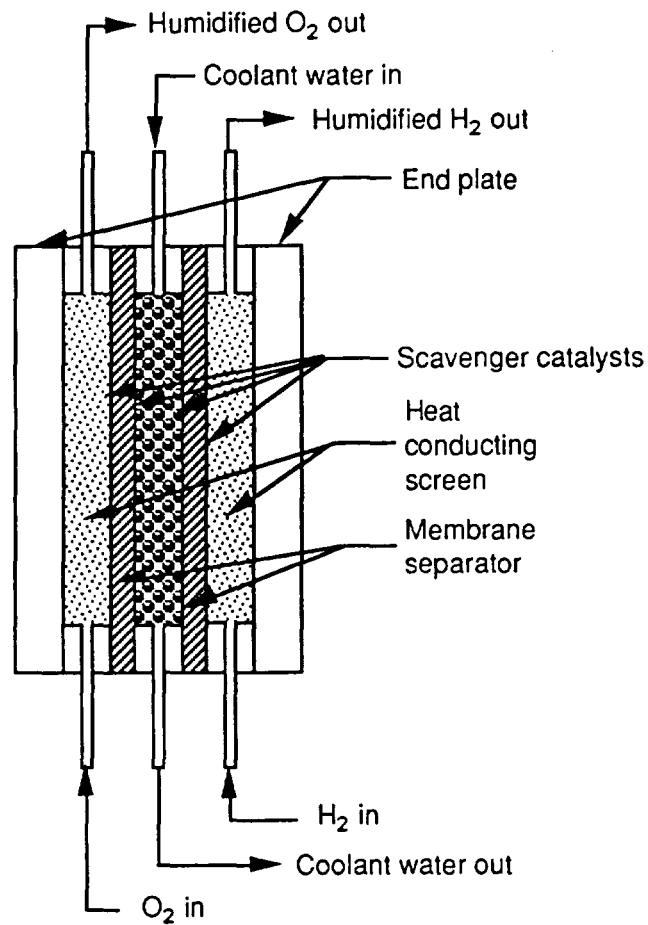

Figure B-6. SPE[®] fuel cell reactant prehumidification approach.

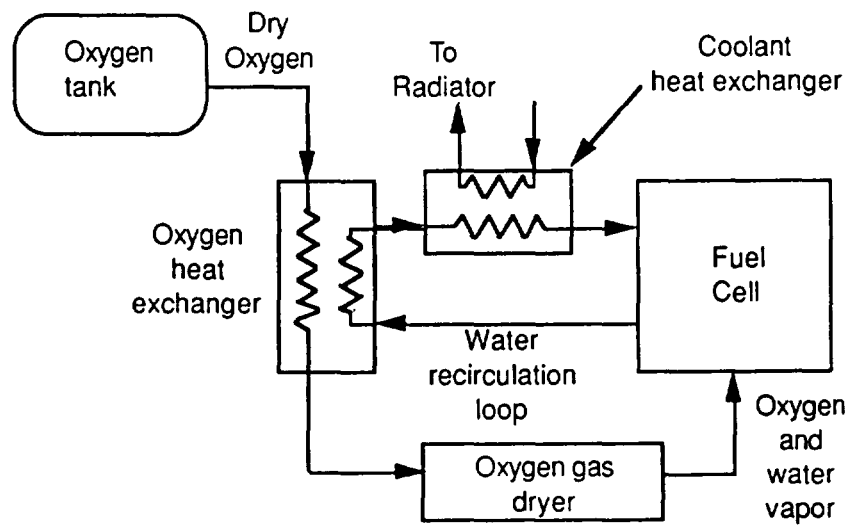

Figure B-7. Water recovery from the oxygen regenerative dryer.

Several approaches have been suggested for recovering moisture from the electrolyzer gases. The key concerns are preventing freezing of water in the lines and the mass loss from the system if the water is not fully recovered each operating cycle. The LANL study (Ref. B-1) proposes letting the water condense and freeze in the tank while keeping the feed lines heated. Some of the water is removed from the tank as a liquid by using a trap. The remainder of the water in the tank freezes. The residual water is recovered by heat input to the tank during the day as additional warm gas from the electrolyzer is introduced.

Another water recovery approach suggested by Hamilton Standard (Ref. B-5) is to dry the gases with regenerative desiccant dryers leaving only a trace of moisture in the gases. This would significantly lower the dew point for the remaining gases to a temperature which is below ambient or would not require much insulation or heat input to prevent condensation. A sacrificial dryer might also remove the remaining trace water. Moisture would be removed from the dryers during fuel cell operation by passing the dry gas from the tanks back through the dryers at the lower fuel cell pressure (need large driving force to recover the water). Potential desiccants include silica gel and molecular sieve (Ref. B-6). Silica gel is used at lower temperatures (below 363 °K) due to its high moisture recycling capacity compared with other industrial desiccants (about 0.35 kg water/kg gel at 303 °K and 80% humidity per Ref. B-7). Molecular sieve is used at higher temperatures (>393 °K) due to its high moisture recycling capacity and physical stability at higher temperatures. Potential configurations for desiccant dehumidifiers include a packed bed, Teflon fiber plates, a corrugated structure, and coated parallel-passages. A coated parallel-passage concept appears to have a great potential to provide an effective dehumidifier. This design consists of parallel-walled passages (laminar flow channels) with fine silica gel particles (80-250 mm) glued to the walls.

Storage Tank Description

For this study, it was assumed that oxygen and hydrogen would be stored at high pressure. The storage tanks will be made of composite materials. A metal liner is overwrapped

with carbon or graphite fibers. The liner will probably be aluminum for the hydrogen tank and a corrosion resistant material such as Inconel, niobium, or tantalum for the oxygen and water tanks.

Reliability and life are the key areas of interest for tank design. Thus, materials must be selected which are stable against corrosion and hydrogen embrittlement for the system life. Current composite tank designs may exhibit high stress when driven through large temperature variations, so the liner materials must be carefully matched to the wrap material in terms of the coefficient of thermal expansion. Otherwise, tanks must be thermally controlled to limit temperature changes (may be difficult when going from non-operating to operating status). Tank linings must exhibit very limited corrosion even with pressurized oxygen storage and perhaps even with wet gas storage. Tanks must be rugged enough to survive the transportation phase of deployment. The use of multiple tanks may be required to meet system reliability requirements. Some elementary cladding may be required to provide an element of shielding from meteorites (the system housing may also be used for this purpose).

PP&C Subsystem Description

The PP&C subsystem has not as yet been defined for this concept. Two basic approaches can be taken. In the first approach, which is the same as for the DIPS, the system is designed to provide a constant power and voltage output. This approach requires a dc voltage regulator to process the fuel cell output. In the other approach, the power conditioning is done at the user loads. In this second approach, the fuel cell output can vary with time (i.e., voltage is unregulated). This approach allows the power processing to be optimized for each load. The power input to the electrolyzer module can also be regulated within the RFC power system or as part of the recharging power system.

TECHNOLOGY ISSUES

The key issues for development of a PEM RFC system and their impacts are summarized in Table B-3. Many of the remaining development issues for this concept are related to system integration. Limited work has been done in this area. Major issues of life and reliability can be resolved with simplified system concepts which utilize fewer components and fewer active components. Earlier PEM cells have already proven themselves in space applications (Gemini fuel cells and SSF RFC prototype) and naval applications (electrolysis cells). Thus, it appears that the remaining technical issues can be resolved and a space qualified system developed which has a reasonable life (20,000 hours or more with a 50% duty cycle). The technical issues and potential solutions will be discussed in more detail in the following paragraphs.

TABLE B-3. PEM RFC DEVELOPMENT ISSUES, IMPACTS, AND DEVELOPMENT AREAS

Issues	Impacts	Potential Development Areas
#1- Limited life components and reliability of many parts	<ul style="list-style-type: none"> •Increased frequency of replacement, maintenance, transportation cost •Mass and complexity of redundant components 	<ul style="list-style-type: none"> •Development of passive system •Long life pumps, drives, valves, and controls
#2 - Material compatibility	<ul style="list-style-type: none"> •Reliability/life 	<ul style="list-style-type: none"> •Materials for use with high pressure O₂ •Materials for wet gases •Materials immune to hydrogen embrittlement
#3 - Cell temperature and moisture control of fuel cell membrane	<ul style="list-style-type: none"> •Life 	<ul style="list-style-type: none"> •Thermal control loops •Passive internal fuel cell gas humidifiers •Regenerative gas dryers
#4 - Oxygen in fuel cell water	<ul style="list-style-type: none"> •Mass/energy loss from the system due to venting of oxygen from water tank 	<ul style="list-style-type: none"> •Internal deoxygenator in fuel cell
#5 - Water in electrolyzer gases	<ul style="list-style-type: none"> •Tank corrosion if wet gas stored (life and reliability) •Tank insulation mass •Complexity of gas dryer systems •Clogging of lines due to ice •Energy and mass loss due to unrecovered water 	<ul style="list-style-type: none"> •Low mass desiccating regenerative dryers •Tank liner materials •Tank and/or line thermal control

TABLE B-3. PEM RFC DEVELOPMENT ISSUES, IMPACTS, AND DEVELOPMENT AREAS
(CONTINUED)

Issues	Impacts	Potential Development Areas
#6 - Large, massive radiator due to low heat rejection temperature	<ul style="list-style-type: none"> • Increased transportation cost, complicated vehicle design (orientation for stability and mobility) 	<ul style="list-style-type: none"> • Higher temperature cells (higher reject temperature) • Low mass carbon-carbon radiator • Heat pump
#7 - Long duration portable applications	<ul style="list-style-type: none"> • Transportation cost • Range limits or need to carry PV array 	<ul style="list-style-type: none"> • Low mass storage tanks • Advanced membrane • Low mass PV arrays
#8 - Reactant storage system mass and volume	<ul style="list-style-type: none"> • Mass/number of trips (transportation cost) 	<ul style="list-style-type: none"> • Low mass high pressure tanks
#9 - High pressure gas storage tank failure	<ul style="list-style-type: none"> • Increased system mass due to higher factor of safety 	<ul style="list-style-type: none"> • Advanced composite tanks and stack pressure vessel
#10 - Efficiency of electrolysis cell reduced at higher pressure	<ul style="list-style-type: none"> • Transportation cost • Increased waste heat; larger radiator 	<ul style="list-style-type: none"> • Low mass tanks, PV arrays, and radiators • Tank pressure following
#11 - High Water Purity Requirement	<ul style="list-style-type: none"> • Life 	<ul style="list-style-type: none"> • Use materials that won't contaminate water • Deionizer

Issue #1 - Limited Life and Reliability

The life of an RFC system for SEI applications is presently unknown. The life of a system depends on the duty cycle for the application among other things. Fixed applications will generally have a 50% duty cycle (half of the time in the fuel cell mode and half of the time in the electrolysis mode). Degradation of the cell membranes is reduced when in a non-operating mode, especially if the temperature is reduced (Ref. B-5). Mobile equipment may have reduced duty cycles (i.e., short operating time and long recharging time). Only equipment common to both the fuel cell and electrolysis modes of operation such as the heat rejection system will be on continuously. A life goal of 20,000 hours for RFC systems (50% duty cycle) was assumed based on current technology and a desire to meet an IOC of 2001 for a lunar landing (Refs. B-1 and B-8). This life goal also corresponded to the life requirement for a lunar mission for earlier Pathfinder studies (Ref. B-8). Long life has been demonstrated (Ref. B-5) in the laboratory on a subscale level for PEM fuel cells (60,000 hours) and electrolysis cells (115,000 hours over 15 years). These have been primarily cell tests with state of the art

membranes (Nafion). Advanced cell membranes made by Dow have not undergone long duration life tests. The major area of concern for life is the moving parts (pumps, valves, regulators, etc.) which have not demonstrated long life for space applications. In the LANL study (Ref. B-1), it is stated that this is a major concern based on the design of current space type hardware. However, pump life can be prolonged if the pumps are operated continuously rather than in a cyclic mode (this is probably required anyway for thermal control of the stacks while in a non-operating condition). Long life RFC systems will be obtained by development of advanced designs or with redundancy for less reliable components.

Passive component design is desirable in an RFC where possible to improve system reliability and life. Passive phase separation (i.e., separation of the water, oxygen, and hydrogen) is desirable and should be easy to accomplish based on terrestrial systems which use a gravity feed approach. Microgravity static phase separators developed for Space Station might also be used for SEI applications.

Issue #2 - Material Compatibility

The electrolysis gas products are saturated with water vapor. The presence of water in the oxygen tank may cause corrosion unless proper precautions are taken. The tank liner should be compatible with a corrosive environment or have a protective coating. Inconel 617, niobium, or tantalum will provide corrosion resistance. However, these materials have not been used as liners for composite tanks (at least not by Structural Composites Industries; Ref. B-9). Current composite tanks are made from aluminum or stainless steel. Plastic coatings could be used as long as the gas temperatures were less than about 370 °K. Aluminum could be utilized as the hydrogen tank liner to prevent hydrogen embrittlement.

Issue #3 - Temperature and Moisture Control

Thermal control and membrane moisture control are required elements for stable, high performance of PEM cells. Temperature control is important because the system produces

liquid water. Freezing of the water in the lines or cell would result in system failure. Excessive temperatures, on the other hand, can cause separator (electrolyte) alterations. Severe membrane dehydration often can result in irreversible failure, due in part to shrinkage and rupture of the separator sheet. Consequently, the system design must include reliable temperature and relative humidity controls. Moisture must also be removed from electrolysis stack gases. Water and thermal control approaches were previously discussed.

Issue #4 - Oxygen in Fuel Cell Product Water

Oxygen gas will accumulate in the water tank if not removed from the product water stream. Eventually, the gas must be vented to prevent vapor lock. The gas which is vented must be replaced and this increases the system mass. A concept developed by Hamilton Standard (Fig. B-4) removes the oxygen from the water while humidifying the fuel cell reactant gases. However, this concept has not been incorporated into a fuel cell design.

Issue #5 - Water in Electrolyzer Gases

The phase separator will only remove the liquid water from the electrolysis cell product gases. A limited amount of water vapor will remain in a high pressure system due to the low operating temperature (water will condense until the partial pressure of the water gives a saturation temperature which matches the bulk gas temperature). The water vapor remaining in the gases can create problems if left in the system. Storage of wet gases in the tanks would require corrosion resistant materials. If not properly insulated or provided with waste heat, then the water may condense on the tank walls and freeze. Water could also freeze in the feed lines from the tanks and prevent gas flow. Several approaches are possible for dealing with these problems as were previously mentioned.

Major issues for desiccant gas dryers include repeatability (i.e., ability to regenerate the desiccant), efficiency (i.e., the percentage of the water which can be removed from the gas and the amount which can be recovered from the desiccant), parasitic power losses (i.e.,

pumping power required), performance degradation, heat input and temperature of gas stream required to regenerate the bed, and preventing freezing of the moisture during regeneration.

Work by Hamilton Standard with a molecular sieve dryer has shown the ability to remove over 99% of the water from a gas stream (Ref. B-5). Pressure drop through the bed can be minimized by proper bed design. A parallel flow path design developed by SERI is one option for a compact, low pressure drop dryer (Ref. B-6). Degradation in dryer performance is mainly due to contamination of the bed. Degradation can be controlled by eliminating contaminants in the system and by use of a closed system. Sufficient heat input must be available to the bed for regeneration to prevent freezing of the water. This is because the regeneration (desorption) is endothermic. Heat transfer enhancement through the use of fins or a high conductivity foam material matrix may be required. The bed must be designed such that regeneration can occur at the low temperatures (about 339 °K) which will be available due to heating of the dry gases by the fuel cell product water. In the past, silica desiccant dryers have been regenerated with air at 394 to 478 °K.

Issue #6 - Large Radiator Due to Low Heat Rejection Temperature

The RFC systems require large radiators due to the low reject temperature (333 °K) and high heat sink temperature (256 °K for vertical radiators and no ground cover). For this study, it was assumed that the radiator would be designed for nominal power levels. It was also assumed that peaking power waste heat loads can be handled by the thermal inertia of the system. This assumption needs to be verified analytically and empirically. Particularly, the effect of higher operating temperature and thermal cycling on cell degradation should be examined.

The large radiation area required for RFC systems results in massive radiators which are a significant portion of the total mass of portable RFC systems. The Martian winds have little effect on cooling of the radiators. It is possible that a forced convection cooling system using a fan might reduce the size of the radiators although at the cost of additional power to run

the fan and reduced system reliability. This opens up other options in radiator placement which would be of benefit on mobile equipment on Mars. Development of low mass radiators is needed to minimize system mass. Development of higher temperature fuel and electrolysis cells would help to reduce radiator size by increasing the radiator heat rejection temperature. However, a higher operating temperature would reduce cell life (see Table B-4) and require the use of a porous metal support for the electrolyzer cell.

TABLE B-4. PROJECTED ELECTROLYSIS CELL MEMBRANE LIFE

Inlet Water Temperature (°K)	Exit Water Temperature (°K)	Projected Membrane Life (hrs)
322	339	262,800
356	378	87,600
422	444	8,760

Issue #7 - Long Duration Systems

Long duration applications such as the rover vehicles would require a large amount of reactants. Requirements for these vehicles would require heavy tanks (both due to the tank mass and reactant mass). Most of the power system mass for these applications is due to the reactant storage. It is not practical for mobile system to carry the large PV arrays required to run the electrolysis stack for Mars applications (due to low insolation rate). However, some cells may be placed on the vehicle exterior surfaces to provide part of the day power and reduce RFC power requirements. Reduced night time power requirements (i.e., for a manned or telerobotic controlled vehicle; assuming no travel during sleep period) for these applications would reduce the power system size and reactant storage required. The mass of the power system could be reduced by reducing tankage mass (i.e., using composite materials), improving cell efficiency (use of new membranes such as that made by Dow), and reducing parasitic power losses (use of passive thermal control, passive product water collection, etc.).

Issue #8 - Reactant Storage System Mass and Volume

The choice of the on-board reactant storage approach also impacts power system mass. Reactants can be stored either as low pressure gases, high pressure gases, or as low pressure cryogenic liquids. A tradeoff must be made between the mass/volume of gas storage tanks versus the mass/power of the liquefier for cryogenic liquid storage in order to select the best approach. High pressure storage offers smaller tanks but reduced safety over low pressure gas. Liquid cryogenic storage offers smaller, more costly tanks and more complex systems (i.e., thermal management). Cryogenic storage systems might have reduced reliability due to increased numbers of moving parts (refrigeration and liquefaction hardware) and complexity. Additional work would be needed to improve liquefier efficiency and reliability to make this approach viable (i.e., to carry along a liquefier as part of an RFC system).

Issue #9 - High Pressure Tank Safety

The safety issues involved with storing oxygen and hydrogen will be more severe a problem than current usage on the Shuttle. Fuel cell reactants on the Shuttle are stored as low pressure cryogens. However, high pressure (2.07×10^7 N/m² or 3,000 psia) PEM electrolyzers are used in submarine applications and the oxygen generated by these cells is stored at high pressure. The space application may require storage of reactants as high pressure gases. Design safety factors for burst pressure will be higher for man-rated systems. The higher pressure requirement will mean heavier tanks and pressure vessels for the electrolysis cells products. Composite gas storage tanks have the advantages of low mass and leakage before burst. Alternatively, reactants may be stored at low pressure as cryogenic liquids. Tank weight will be more of an issue for lunar systems than for Mars systems due to the longer storage time.

Issue #10 - Reduced Efficiency of Electrolysis Cells at Higher Pressure

There is a diffusional inefficiency in PEM electrolysis cells which increases as the operating pressure increases. High pressure operation of an electrolysis cell requires that part of the current input be used to compensate for this back diffusion. For the 2.07×10^7 N/m² (3,000 psia) NASA JSC unit, which operates at a nominal current from 180 to 350 amps, it takes 15 amps just for back diffusion compensation (up to 8% of the total input). This results in a larger charging power system to drive the electrolysis unit. Thus, one must tradeoff between the size and mass of a photovoltaic array (or other power system) and the size and mass of storage tanks required for lower pressure systems. For the short operating times required on Mars it is probably better to operate at a lower pressure than for a lunar system. However, this tradeoff needs to be quantified.

Issue #11 - High Water Purity Requirement

PEM separators are susceptible to ionic contamination in the electrolysis mode. The presence of metallic cations must be controlled. Thus, the use of high purity water is required for the PEM electrolysis cell to maintain performance (preserving high activity of the electrocatalysts and maintaining high ion exchange capability of the membranes). In addition, the impact of dust contamination in the system must be studied to determine potential system impacts. Potential development of new membranes which are more tolerant of impurities is a possibility. Alternatively, the system should be completely clean when assembled and be made of materials which will not contaminate the water. A closed system where reactants are never replaced would eliminate external contamination. These latter two approaches would eliminate the need for maintenance of a water purifier such as a deionizer and any particulate filters. However, a closed system would eliminate the option of replacing reactants from a centralized electrolyzer (i.e., primary fuel cell approach).

REGENERATIVE FUEL CELL POWER SYSTEM TECHNOLOGY ROADMAP

TECHNOLOGY ASSESSMENT

The technology bases were assessed for the following major RFC subsystems:

- fuel cell stack;
- electrolysis cell stack;
- thermal management;
- water management;
- reactant storage tanks; and
- PP&C.

The technology readiness of each assembly was evaluated using the NASA technology readiness levels. These evaluations are summarized in Table B-5 which shows that the RFC has technology readiness levels ranging from 3 to 5, depending on the particular subsystem. The technology base for each assembly is briefly discussed in the following sections.

TABLE B-5. RFC TECHNOLOGY ASSESSMENT

Subsystem	Technology Readiness Level	Comments
Fuel cell stack	3.5	Early design flown on Gemini; prototype developed for space station RFC based on earlier Hamilton Standard design; new International Fuel Cell design not flown (engineering qualified in 2.5 yrs for DARPA program)
Electrolysis cell stack	4	Large database for naval applications; prototype developed for space station applications
Active thermal management	3	Advanced C/C heat pipe radiator development currently underway; long life active components not developed for space applications; some sealed water pumps and drives for terrestrial applications have demonstrated long life
Water management	4	Passive phase separation designed for Space Station Freedom (SSF) prototype; silica gel dryers widely used for gas drying in terrestrial applications; limited experience with regenerative gas dryer systems
Reactant storage tanks	5	Small tanks successfully flown; need corrosion resistant liner development
PP&C	5	SSF

RFC System State-of-the-Art

Hamilton Standard designed, developed, tested, and delivered a 1.5 kW PEM breadboard RFC system to JSC in January 1983 (Ref. B-5). The RFC breadboard system was tested for 2,000 total ninety minute orbital cycles (1,630 by NASA). The fuel cell module of the RFC was later replaced by an advanced module and tested for about 500 hours. This breadboard was not tested in a relevant environment (i.e., vacuum or low pressure carbon dioxide, low gravity, day/night thermal cycles, etc.). In addition, the breadboard did not include key components such as composite tanks, radiators, and long life active thermal control components.

Although the fuel cell technology is fairly well developed in PEM systems, the system integration of the accessory components and cell stack is not as mature as that of the alkaline fuel cells. The technology readiness of the PEM RFC is estimated to be 3.5 for the current application.

Fuel Cell State-of-the-Art

A PEM fuel cell developed by Hamilton Standard (United Technologies) was used on the Gemini missions from 1962-66 (Ref. B-10). After the Gemini space flights, Hamilton Standard pursued further development of PEM fuel cell technology. The major breakthrough was the replacement of polystyrene sulfonic acid ion exchange membrane by perfluorinated sulfonic acid polymer, Nafion, produced by DuPont, as the electrolyte. PEM fuel cell technology has since advanced with the introduction of the Dow experimental membrane. The Dow membrane has greatly increased the current density of PEM systems over the current densities available from DuPont's former state-of-the-art membrane, Nafion 117. Dow has not yet started production of their membrane, but is supplying it to fuel cell manufacturers for testing and evaluation.

Cell lives of 60,000 hours (6.85 years) in the laboratory have been achieved by Hamilton Standard with PEM fuel cells (Refs. B-4 and B-5) because there are no corrosive electrolytes to cause contamination. PEM fuel cells can operate with high concentrations of

gases like CO₂, whereas the KOH electrolyte of alkaline fuel cells would react with the CO₂ and cause precipitation.

A PEM fuel cell subsystem was developed by Hamilton Standard in the 1980s for a RFC demonstrator for the Space Station Freedom (Ref. B-2). The fuel cell had a 1 to 2 kWe rating. The RFC demonstrator underwent parametric testing at the factory prior to its delivery to NASA/JSC.

Treadwell Corporation has designed and built a PEM fuel cell stack and associated test stand (Ref. B-11). The stack was designed for an output power of 10 - 30 kW. Various stacks have been tested. This fuel cell system was designed for autonomous underwater vehicles.

Ballard Technologies Corporation in Canada has built small demonstrator stacks with the Dow membrane and was the first to achieve high power densities in a solid polymer electrolyte fuel cell (Ref. B-10). The Ballard design appears to be similar to the Hamilton Standard fuel cell design.

Siemens in Germany (under a license from Hamilton Standard) is also using the PEM technology to develop fuel cell systems for submarine power systems (Refs. B-10 and B-12).

LANL has two of the Dow PEM fuel cells on test, achieving 0.92 V at 2153 A/m² (Ref B-10). Dow has made a commitment to provide membranes to a product specification; whereas, they were previously in process development and membrane quality/consistency were not up to par for commercial use.

PEM fuel cells are well suited to passive water removal. The absence of a liquid electrolyte that has narrow concentration limits makes water management less of a problem. Ergenics Power Systems, Inc., is developing a flight-qualified 200 W fuel cell with passive water and heat removal for a Space Station extravehicular mobility unit (Ref. B-10).

International Fuel Cells (IFC) has tested a 16 cell, 5 kW stack using Nafion membranes and is now evaluating the Dow membranes. This is a new PEM design which is different from the fuel cell which flew on Gemini. IFC also worked on a "static" PEM fuel cell (Ref. B-13). This concept eliminated the power consuming pumps associated with the management of the product

water. The design also incorporated heat pipes into the system to create a "static" waste heat management subsystem which eliminated the cooling subsystem parasitic power loss. This approach offered significantly improved reliability and higher system efficiency. IFC completed breadboard experiments and validated this system concept. IFC has since changed their design (Ref. B-14). The latest design has no heat pipes and requires a cooling loop with a pump. However, the water removal still utilizes a static approach. This concept is proprietary and few details were available from IFC. However, this concept uses graphite plates and either Dow or Nafion 117 membranes (Nafion is the baseline). IFC has tested both single cells and short stacks with its latest design. IFC has a DARPA contract to produce a 7.5 kWe fuel cell for unmanned underwater applications. This power plant will be available (engineering qualified) in 2.5 years. The life of this fuel cell is expected to be a few thousand hours. The DARPA fuel cell technology should be suitable for space since it is not affected by a zero gravity environment.

Electrolysis Cell Stack State-of-the-Art

Hamilton Standard has an extensive data base in high-pressure electrolysis. The 2.07×10^7 N/m² (3,000 psi) cell design is currently used in the oxygen generation plant (OGP) developed for the U.S. Navy and in the production units for the British Navy nuclear submarines. Hamilton Standard has over 20 years experience building PEM electrolyzers for the Navy (Ref. B-10). They have demonstrated 13 years of continuous usage of a PEM electrolyzer cell in the laboratory. U.K. Navy electrolyzer cells have accumulated a total of 69,000 system hours of usage as of January 1992 without any failures. One Navy electrolyzer cell stack has accumulated over 13,000 hours of usage at sea over a 5 year period (Ref. B-5).

During the 1980s, three demonstrators were developed by Hamilton Standard (Ref. B-2). These electrolyzers were fabricated and then tested by NASA. Each of these systems made use of the identical 213 cm² SPE[®] water electrolyzer design used for naval applications.

REGENERATIVE FUEL CELL POWER SYSTEM TECHNOLOGY ROADMAP

The first of these systems was a PEM RFC demonstrator for Space Station Freedom. Over 2,000 simulated orbital cycles were accumulated on this hardware. This program demonstrated a closed system fluid cycle balance, direct solar array/electrolyzer voltage/current control compatibility (no power conditioning required), and an energy storage efficiency of 48% with the electrolyzer at ambient temperature. Later in the program the PEM fuel cell was replaced by an alkaline fuel cell and the system was operated for 100 cycles with no problems. This test showed the compatibility between a PEM electrolyzer and an alkaline fuel cell (i.e., no KOH ions went to the PEM electrolyzer through the product water and no sulfonic acid groups passed through the PEM electrolyzer gases to the fuel cell; some people had thought that the acid and base in each unit would mix and neutralize each other). Recently, some of the electrolyzer cells were replaced by high performance cells using the Dow membrane. The electrolyzer module underwent additional testing and showed significant performance improvement, especially at higher current densities.

The second Hamilton Standard demonstrator was an oxygen generator assembly developed under contract to Boeing Aerospace and Electronics Company (Ref. B-2). The operating pressure, temperature and current density of this demonstrator are within the experience of naval applications. However this demonstrator differed from the Navy data base because of the need to operate in a microgravity environment and use processed hygiene water as the feedstock. Two membrane static phase separators are used to replace the pressure vessel phase separators used previously. The demonstrator was activated at NASA/MSFC in November 1990 and operated for 529 hours which exceeded the test objective of 450 hours. This program successfully demonstrated the operation of microgravity phase separators. There are continuing tests of this unit to improve the cell voltage performance.

The third Hamilton Standard demonstrator system was developed to show the feasibility of producing 2.07×10^7 N/m² (3,000 psi) hydrogen and oxygen on orbit for periodic rocket motor firing to maintain Space Station Freedom orbital altitude (Ref. B-2). Under NASA sponsorship, initial work was performed to convert the heavy 2.07×10^7 N/m² (3,000 psia)

naval SPE[®] electrolyzer design into a space flight configuration (Ref. B-4). This required development of a lighter and smaller package. Changes were made to the supporting pressure vessel and fluid manifold. The use of two torispherical domes opposed on either side of a central fluid plate allowed for a wall thickness of as low as one quarter of an inch when using Inconel or other high strength materials. The fluid plate manifold is pressure balanced between the two pneumatic domes which eliminates the need for a thick plate to resist the gas pressure load, as used in the Navy hardware. This work produced a prototype cell stack for space applications that weighs less than 91 kg total (down from 454 kg for the 100-cell naval cell stack and pressure vessel). This unit was delivered in 1990. This demonstrator has been set up and operated intermittently at NASA/JSC during the last year. This cell was recently tested by JSC for 500 hours (Ref. B-2). This unit operates at 322 °K at a thermal efficiency greater than 70% (defined as the ratio of the power input minus the heat rejected to the power input).

Thermal Management Subsystem State-of-the-Art

NASA LeRC is currently carrying out an integrated multi-element project for the development of space heat rejection subsystems with special emphasis on low mass radiators in support of SEI power system technology (Ref. B-15). This effort involves both in-house and contracted efforts. Contracted efforts involving Rockwell International (RI) and Space Power Incorporated (SPI) are aimed at the development of advanced radiator concepts (ARC). NASA LeRC is also involved in a joint program with DOE to demonstrate a flexible fabric heat pipe radiator concept being developed by Pacific Northwest Laboratories (PNL). In-house work at NASA LeRC is designed to guide and support the overall program by system integration studies, heat pipe testing and analytical code development, radiator surface morphology alteration for emissivity enhancement, and composite materials research focused on the development of low mass, high conductivity fins. This program is concentrating on technologies capable of development before the end of the decade for both surface power and nuclear electric propulsion (NEP) applications.

Specific objectives of the ARC contracts are to achieve specific mass values $<5 \text{ kg/m}^2$ with radiator surface emissivities of 0.85 or higher at typical radiator operating temperatures, and reliability values of at least 0.99 for the heat rejection subsystem over a ten year life. These figures represent a factor of two improvement over the currently considered heat rejection subsystem for SP-100, and even greater improvement factors for state-of-the-art heat rejection systems used in current spacecraft applications.

Presently, Rocketdyne division of Rockwell International is involved in the development of a carbon-carbon (C-C) or graphite heat pipe radiator panel. Rocketdyne has a NASA contract entitled "SP-100 Advanced Radiator Concepts" which started in 1987 and is part of the CSTI (Civilian Space Technology Initiative) program. This program will be completed in January of 1993. This program involves development of a C-C heat pipe suitable for use in an SP-100 radiator. However, this technology will be suitable for other radiator applications as well including RFC power systems (using other working fluids such as water and/or ammonia). The hope is that this program will develop generic technology which can be used for all future space radiators because of its reduced mass compared to metal heat pipe radiators. Carbon-carbon is a new structural material which requires different fabrication techniques than for metals or composites. A key objective of this program is to demonstrate the ability to fabricate C-C heat pipes with a thin metal liner, wicks, caps, and fill tube. The brazing technique required to attach liners is the same as would be required to attach manifolds to the heat pipes. Heat pipes filled with potassium will be designed, fabricated, and tested during this program. Thermal cycle testing will be done in a vacuum to demonstrate the integrity of the heat pipes.

Beginning in 1989, small samples of heat pipe panels were fabricated by Rocketdyne as part of the CSTI program. The next phase of the program will involve fabrication and testing of complete heat pipes about a meter long.

The working fluids and temperatures for the SP-100 system would be different than for lower temperature RFC systems. Thus, Rocketdyne has an on-going IR&D effort which involves development of a high pressure water C-C heat pipe for lower temperature applications such as

RFCs. This effort will eventually include fabrication and testing of a heat pipe. Rocketdyne is also looking at a higher thermal conductivity C-C heat pipe design.

Recent Rocketdyne studies have shown that a C-C heat pipe with water or ammonia is competitive on a mass basis with early metal heat pipe radiator technology developed in the late 1960s and early 1970s as well as pumped loop radiators. Rocketdyne studies have estimated the C-C radiator specific mass to be about 3 kg/m².

The objective of the joint NASA LeRC/Air Force program with PNL (Light Weight Advanced Ceramic Fiber [ACF] Heat Pipe Radiators) is to demonstrate the feasibility of a low mass ceramic fabric/metal liner heat pipe for a wide range of operating temperatures and working fluids (Ref. B-15). Specifically, the NASA LeRC objectives are to develop this concept for application to space radiators with operating temperatures below 500 °K using water as the working fluid. The specific mass goal for these heat pipes is 3 kg/m² or less at a surface emissivity of greater than 0.85.

Several heat pipes were built for the ACF program using titanium and copper foil material for containment of the water working fluid. A heat pipe with an eight mil Ti liner was demonstrated in early January 1991. An innovative "Uniskan Roller Extrusion" process has also been developed at PNL and used to draw 30 mil wall tubing to a 2 mil foil liner in one pass. The water heat pipes fabricated for LeRC have been subjected to a test program to evaluate performance and reliability at demanding operating conditions.

Future thrusts of the ACF program will be to perfect the heat pipe fabrication procedure using very thin (0.025 to 0.05 mm) foil liners which are internally texturized by exposure to high pressures (Ref. B-15). Plans will also be developed to perform hyper-velocity and ballistic velocity impact tests in order to determine if secondary fragments from a penetrated heat pipe will result in failures of neighboring heat pipes. Another major challenge will be to design a heat pipe with high conductivity, low mass fins as a first step toward the fabrication of low mass radiator panels.

The NASA LeRC in-house materials program includes radiator surface morphology

alteration by arc texturing for emissivity enhancement purposes (Ref. B-15). Emissivity enhancement has been demonstrated for graphite-copper samples.

Another important part of the thermal management subsystem is the active controls for controlling fluid flowrates and pressures. This involves the development of long life pumps, valves, and regulators. Hamilton Standard has used 2.07×10^7 N/m² (3,000 psia) water pumps for its U.S. Navy electrolysis units (made by J.C. Carter Company per Ref. B-5). These pumps have lasted over 10,000 hours. Hamilton Standard also has used a small 0.91 m³/h (4 GPM) pump for recirculating water to a fuel cell which lasted over 10,000 hours. Existing active convective transport hardware (pumps, centrifugal water separators, fans) have also been developed for space systems by GE and Hamilton Standard, but not for long life (Ref. B-1). Experts in the field believe that these components will have lifetimes of less than 2,000 hours in a space environment.

Water Management Subsystem State-of-the-Art

Water management involves both gas humidification to maintain proper cell membrane moisture content as well as gas dehumidification to prevent water condensation and freezing. Work has been done in both of these as areas, but not for space qualified hardware.

Gas humidification for production PEM fuel cells has been successfully done by Hamilton Standard using the approach shown in Figure B-6. An improved approach which removes oxygen from the product water was shown in Figure B-4. This approach was demonstrated in the laboratory in 1989, outside of a fuel cell (Ref. B-5). This approach has not yet been integrated into a PEM fuel cell design.

Water vapor can be removed from gases using condensation, absorption, adsorption, or a combination of these techniques. Gas drying is a well-known technical process. General Dynamics proposed (Ref. B-16) a system which utilizes condensation for removing 99.9% of the moisture from oxygen and hydrogen gases. The removal of the remaining moisture was assumed to be accomplished using absorption-adsorption techniques in existing ground

liquefaction systems. General Dynamics adapted a system developed by Atlas Copco called MD sorption drying for propellant processing. This process recovers all of the water during the electrolysis portion of the cycle. However this is a very complex system with many moving parts (pumps, valves, and rotor in sorption dryer). In addition, this system increases the radiator size by reducing the heat rejection temperature.

Work was done with regenerative gas dryers for Hamilton Standard by the UTC Research Center in 1987 (Ref. B-5). These dryers use a molecular sieve to remove water. In tests, a humidified gas stream was run through a dryer bed for 36 hours without breakthrough. A 10% bed loading (amount of bed volume which was water) was achieved. An outlet dew point of less than 183 °K was obtained with a 100 to 1 gas volume ratio. Such a dryer removes about 99.9% of the water vapor from a gas. Based on this work, a 21 kg desiccant could be made regenerable and deliver 2,939 kg of dry gas (about twice that required for a 12.5 kW lunar base system). A much smaller unit would be required for a Mars system. Hamilton Standard has also looked at methods to reduce dew point temperature down to liquid hydrogen temperatures.

Reactant Storage Tank State-of-the-Art

Gas storage tanks have had considerable engineering advancement, both in earlier NASA programs and throughout the commercial sector. Gas tanks have become safe, reliable commodities, widely used in science and technology. Composite tanks with a metallic liner and a polymer wrap are generally considered for advanced space applications.

Composite tanks have had considerable recent development for a wide range of sizes (Ref. B-9). Structural Composite Industries (SCI) has built many tanks for both terrestrial and space applications. These cylindrical tanks have either aluminum or stainless steel liners. These liners are seamless and are made from plate stock without welding. SCI has developed tanks for Space Station, Brilliant Pebbles, HEDI, propellant tanks for launch vehicles, communications satellites, and Pegasus projects among others. Eleven of these tanks have been launched into space. Tank sizes have ranged from 754 cm³ to 0.66 m³ (Space Station). A

recent effort involved a tank which is 4.06 m long and has a 0.53 m outer diameter. A current effort involves the development of a 1.42 m diameter tank. Tank pressures have gone as high as 1.034×10^8 N/m² (15,000 psia) for operation and 2.068×10^8 N/m² (30,000 psia) for burst. Tanks for SDI missions are designed for 5 year life. Additional liner development may be required for storage of wet oxygen.

PP&C Subsystem State-of-the-Art

The PP&C system design is based on a reasonable electronics component evolution, and there are no significant technology issues associated with its development. It will be necessary to fabricate breadboard hardware for testing and evaluation purposes, but there is no need to initiate any advanced component development. Most of the hardware elements have been or shortly will be operating in a relevant environment on other spacecraft or the SSF electrical power subsystem.

MAJOR DEVELOPMENT TASKS

The development program was divided into 9 major tasks. The first six tasks are component development tasks. The remaining tasks involve the system design, fabrication, integration, safety assurance, and testing.

Testing will be done on the component, subsystem (fuel cell stack, electrolysis cell stack, thermal management, gas dryers, storage tanks), and system level (qualification testing). The system level tests will show any possible negative interactions between subsystems.

The RFC development tasks are described in the following sections. Each task will include a section on objectives and a statement of work. The task descriptions are only approximate and depend on the RFC design chosen.

A 3 kWe nominal power (peaking power of 10 to 15 kWe) module with an energy storage capability of 32 kW h (net output) will be selected for the ground engineering system (GES) to

take the RFC technology through Technology Maturity Level 6 (system validation model demonstrated in a simulated environment). Other power module sizes may be built and qualified for flight systems.

Task 1. PEM Fuel Cell Module Development

Objectives: Develop a full scale, long life (10,000 hours continuous) flight weight fuel cell module which can be integrated into a mobile RFC power system. Demonstrate materials compatibility, safety, and performance margins.

Statement of Work: This effort was divided into the following subtasks:

Subtask 1.1 Preliminary Fuel Cell Module Development. Demonstrate the feasibility of the selected fuel cell design for planetary surface applications. Investigate stack sealing materials, plates, membranes, humidifier, and diluent control. Test a prototype fuel cell stack to demonstrate materials compatibility, and safety.

Subtask 1.2 Final Fuel Cell Module Design. Design a full scale flight weight fuel cell modules (one or more different sizes).

Subtask 1.3 Fuel Cell Module Fabrication, Assembly, and Testing. Build and test (performance, mechanical, and thermal cycling) the fuel cell module. After initial breadboard validation testing is complete, perform additional module testing in a relevant environment.

Task 2. PEM Electrolysis Cell Module Development

Objectives: Develop a full scale, long life (10,000 hours continuous) flight weight electrolysis module which can be integrated into a mobile RFC power system. Demonstrate materials compatibility, safety, and performance margins.

Statement of Work: This effort was divided into the following subtasks:

Subtask 2.1 Preliminary Electrolysis Cell Module Development Design. Demonstrate feasibility of the selected concept for space applications. Investigate options for the cell membranes, pressure vessel, central fluid plate, and electrical connections. Demonstrate

materials compatibility, performance, and safety using a prototype cell stack.

Subtask 2.2 Final Electrolysis Module Design - Design a full scale flight weight electrolysis cell module.

Subtask 2.3 Electrolysis Module Fabrication, Assembly, and Testing. Build and test (performance, mechanical, and thermal cycling) the full scale electrolysis cell module. After initial breadboard validation testing is complete, perform additional module testing in a relevant environment.

Task 3. Thermal Management Subsystem Development

Objectives: Develop and demonstrate a low mass, reliable heat pipe radiator. Develop and demonstrate long-life (20,000 hours continuous) active thermal control components (pumps, valves, regulators, etc.), as needed. Develop and demonstrate thermal control concepts for all components in the RFC system.

Statement of Work: This effort was divided into the following subtasks:

Subtask 3.1 Heat Pipe Demonstration. Fabricate and test representative length heat pipes to fully characterize heat pipe performance. Compare test results with predicted performance over the anticipated range of operating conditions including startup, shutdown, and restart.

Perform limited life testing of the heat pipes. Identify deterioration mechanisms, measure deterioration rates, and assess the adequacy of assembly and cleaning procedures. Withdraw heat pipe samples sequentially throughout the test period. Drain, section, and analyze the samples for corrosion, carbon diffusion, braze stability, and any other signs of deterioration.

In conjunction with the heat pipe performance and life testing, develop and demonstrate techniques for nondestructive examination (NDE) of the heat pipe elements and assembly. Assess the adequacy of liner bonding and weld joints. Determine if the correct fit-ups and interfaces were obtained in the assembled piece.

Subtask 3.2 Radiator Enhancement. Increase the applicability of the radiator concept by performing various enhancement tasks. Examine survivability options and extended length heat pipes.

Perform analytical assessment, testing, and enhancement design development to insure long life for both lunar and Mars missions. Consider natural threats such as micrometeoroids and dust erosion (Mars).

Fabricate a long heat pipe. Develop alternate techniques for fitting the liner into the tube. Investigate alternative tube fabrication, liner fabrication, and coating processes.

Subtask 3.3 Heat Pipe Integration and Testing. Develop and demonstrate techniques for thermal and mechanical bonding of the heat pipe to the radiator manifold. Subsequently, demonstrate heat pipe integration into a representative radiator section. Test the radiator section to provide an accurate overall heat transfer coefficient. Verify radiator dynamics and performance. Include a surrogate manifold section and a limited number of heat pipes in the demonstrator. Test the assembled unit in a cold wall, vacuum chamber, simulated space environment. Validate temperature drop predictions, verify manifold design, and assess component interactions.

Subtask 3.4 Radiator Module Design, Assembly, Fabrication, and Testing. Develop the detailed design of the radiator subsystem. Resolve specific design issues such as the effects of differential thermal expansion, deployment features, monitoring instrumentation and control equipment, local insulation, and trace heating of the manifold and piping.

Design, fabricate, and test a representative full scale heat pipe radiator and interface heat exchanger. Complete performance, mechanical (stress, shock, and vibration), and thermal cycling tests.

Subtask 3.5 Preliminary Active Component Development. Perform preliminary development of water circulation pumps and other active fluid components. Identify life limiting components and failure mechanisms of current designs. Develop design approaches with improved life capabilities. Design and build prototype components. Demonstrate materials

compatibility, safety, and performance margins.

Subtask 3.6 Final Active Component Design. Design the full scale components and develop the active control subsystem concept.

Subtask 3.7 Active Control Subsystem Fabrication, Assembly, and Testing. The final components will be designed and integrated into a fluid subsystem test bed with simulated thermal loads and pressure drops for other RFC components. Testing shall include performance, shock, pressure, and safety tests. After initial breadboard validation testing is complete, perform additional testing in a relevant environment.

Task 4. Water Management Subsystem Development

Objectives: Develop reliable, long life (20,000 hours continuous) regenerative dryers for removing water vapor from the electrolyzer product gases. Develop an approach for recovering water from dryers. Develop a reactant gas humidification device for the fuel cell for maintaining a proper membrane moisture content.

Statement of Work: This effort was divided into the following subtasks:

Subtask 4.1 Gas Dryer Development. Develop regenerative gas dryers for use with wet hydrogen and oxygen gas streams. Design the dryers to remove the majority of the water vapor from the gas streams with reasonable size and mass hardware. Build prototype dryers. Test the dryers in the adsorption and desorption modes. Determine materials compatibility, regenerability, cyclic performance degradation, and efficiency.

Perform studies to determine the effect on system performance of any remaining moisture after leaving the regenerative dryers. Design an approach for recovery of the remaining moisture from the gas system. Develop additional components as necessary to handle this remaining moisture. Demonstrate analytically and empirically the performance of this additional hardware.

Subtask 4.2 Gas Humidifier Development. Complete the development of reactant humidifiers which are integral to the fuel cell. This will include modification of existing

humidifier concepts which currently work external to the fuel cell. In addition, this task will be done in parallel with fuel cell development to allow for proper integration with the fuel cell stack design.

Task 5. Reactant Storage Tanks

Objectives: Develop reactant tanks for storage of wet hydrogen gas, wet oxygen gas, and water. Develop tank and tank feed line thermal management (insulation and/or heat recovery from fuel cell stack) approaches to prevent composite tank failure, and prevent ice blockage of gas lines and regulators.

Statement of Work: Design, fabricate, and test the reactant storage tanks. Develop corrosion resistant liners and fabrication techniques for the oxygen and water tanks. Consider the requirements for micrometeoroid protection in the tankage design.

Develop insulated and/or heated tank concepts which prevent water condensation and freezing in the gas storage tanks and exit lines. Demonstrate proper transient performance of the tanks using analysis techniques. Build and test prototype tanks. Demonstrate materials compatibility and safety. Perform proof testing, pressure cycling (at different temperatures), thermal cycling (while under pressure), puncture resistance, and mechanical shock tests. Measure tank permeability to estimate leakage losses, especially for hydrogen.

Task 6. PP&C Subsystem Development

Objectives: Develop electronic devices for regulating output voltage and for controlling RFC operation. Demonstrate adequate steady state and transient performance, and immunity to the environment (including launch and operating). Demonstrate the software capability to handle power system nominal operation and failure modes.

Statement of Work: This effort was divided into the following subtasks:

Subtask 6.1 Electrical Components. Build breadboard units to demonstrate and check functional performance of the individual component circuit designs. Incorporate any necessary design modifications and improvements into brassboard units. Verify functional performance within the constraints of the actual component configuration. Fabricate prototype units and perform a series of tests using simulated input and output loads. Test the controller to validate the operating system software. Include the following testing:

- start up, steady state and transient control;
- failure simulation and detection and switching;
- effects of temperature extremes and thermal shock;
- effects of environment;
- shock and vibration;
- cold plate heat loads; and
- EMI generation and susceptibility.

Subtask 6.2 Software. Check out the controller software using simulated inputs and outputs.

Task 7. Ground Engineering System (GES) Testing

Objectives: Design a system concept which will meet both lunar and Mars mobile power applications. Show the concept feasibility. Verify adequate performance and life for an integrated system.

Statement of Work: This effort was divided into the following subtasks:

Task 7.1 GES Design. Identify and characterize specific power system applications. Determine power system requirements. Define optimum power system module size based on trade studies which minimize the overall life cycle cost of the power system for all applications (trade between development cost and mass).

Identify concepts which can meet early lunar base applications. Power system enhancements, if any, required for Mars applications will be identified. Perform tradeoff

studies (performance, reliability, risk, safety, and life cycle cost) to select the optimum system design. Complete feasibility studies for the selected concept including off-design and transient analysis. Definitize the remaining hardware development tasks based on the system concept chosen.

Design a complete RFC system to at least meet the minimum life requirement of 20,000 hours (10,000 hours for the fuel cell and electrolysis cell stacks). Integrate the entire thermal and water control system including pumps, controls, lines, valves, heat exchangers, tanks, and radiator. Perform both design point and transient analyses to verify the design. Perform this task in parallel with the component development tasks to insure proper system characteristics

Task 7.2 GES Performance Tests. Manufacture the GES components and assemble. Pressure and leak check the assembly, fill the water storage tank, complete a electrical check-out, and check out all active devices to the extent possible.

Design the test program for the GES to verify all performance characteristics of the unit in conjunction with subjecting the GES to acceptance level tests. Conduct performance and thermal vacuum tests during a single thermal vacuum test sequence to demonstrate technical capabilities while minimizing program cost. Complete the following performance testing activities:

- checkout and refine subsystem assembly procedures;
- verify operation of ground support equipment (GSE) and interfaces with the GES;
- verify start up capability;
- verify steady state performance characteristics;
- establish effective operating range of the system;
- check out software and verify autonomy (include all operational modes and simulate failure modes);
- simulate normal switchover from one module to another;
- simulate failures to trigger module switchover; and

- establish system sensitivity to off-normal conditions such as: (1) partial loss of radiator cooling, (2) varying radiator heat removal profile, (3) partial loss of electronic cooling, and (4) temporary losses of heat sink with varying duration.

Task 7.3 GES Life Test. Refurbish the GES after completion of performance,

acceptance, and margin tests. Refurbishment will include the following:

- replacing or repairing components as necessary to ensure that the GES is returned to its as-built condition;
- addition of special instrumentation required for the life test phase; and
- modification of the main radiator heat removal system or replacement of the main radiator with a dump heat exchanger.

Install instrumentation to provide a comprehensive diagnosis of the "health" of the GES and to monitor for degradation of major assemblies and individual components. Place the GES on a 20,000 hour life test (50% duty cycle for the fuel cell and electrolysis cell stacks). Operate the GES at its nominal operating point, with expected GES variations in power output and environment.

Disassemble the GES for diagnosis at the end of the life test. Determine areas to be examined by an analysis of the health monitoring data and from the reliability analysis predictions.

Task 8. Qualification Program Testing

Objectives: Fabricate the qualification units (QUs) Verify adequate performance and life for the QUs.

Statement of Work: Develop a comprehensive performance and dynamic testing program which will provide a formal demonstration that the RFC system will perform as designed after being subjected to simulated launch conditions. Select launch environmental conditions which envelope the probable intensities developed by various launch scenarios.

Begin the qualification effort (a typical approach is shown in Figure B-8) by qualifying the assemblies. Fabricate and assemble the qualified production items into the QU. Qualify the QU by the rules for space vehicle qualification.

This effort was divided into the following subtasks:

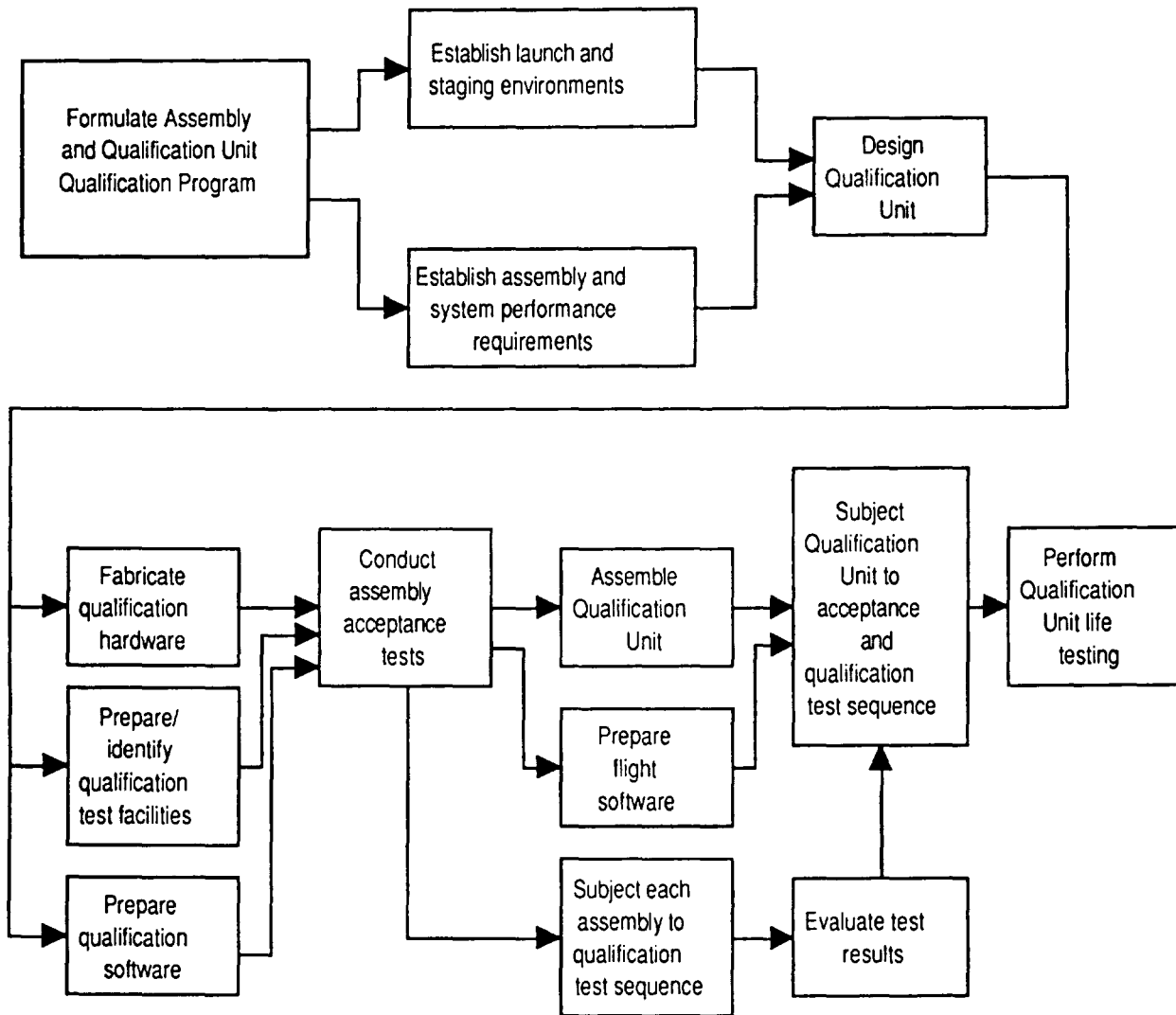

Figure B-8. RFC power system qualification program.

Subtask 8.1 Qualification Performance Testing. Conduct performance testing at each level to verify that each item performs as designed. Perform dynamic testing to verify the capability of the RFC system to withstand launch loads, including acoustic, pyroshock and vibrational. A possible performance and dynamic qualification test sequence for components and assemblies is shown in the matrix of Figure B-9. The corresponding qualification test sequence for the QU is shown in Figure B-10.

REGENERATIVE FUEL CELL POWER SYSTEM TECHNOLOGY ROADMAP

Subtask 8.2 Qualification Life Testing (Optional). After completion of the qualification performance testing, partially disassemble the QU and examine the unit. Refurbish the QU as required and modify for endurance testing in air, as described for the GES. Life test the QU for 8,800 hours or more.

Component or Subassembly	Functional (1)	Leak	Pyroshock	Functional (2)	Random Vibration	Functional (1)	Leak	Acceleration	Functional (1)	Thermal Cycling	Functional (2)	Thermal Vacuum	Functional (2)	Pressure	Leak	EMC	Life	Functional (1)
Fuel Cell Stack	X	X	X	X	X	X	X			X	X	X	X	X	X	X	X	X
Electrolysis Cell Stack	X	X	X	X	X	X	X			X	X	X	X	X	X	X	X	X
Reactant Storage	X	X	X	X	X	X	X			X	X	X	X	X	X		X	X
Thermal Management	X	X	X	X	X	X	X					X	X	X	X		X	X
Water Management	X	X	X	X	X	X	X			X	X	X	X	X	X		X	X
PMAD	X		X	X	X	X				X	X	X	X			X	X	X
Structure	X		X	X	X	X		X	X	X	X						X	X

Figure B-9. RFC power system assembly qualification test matrix.

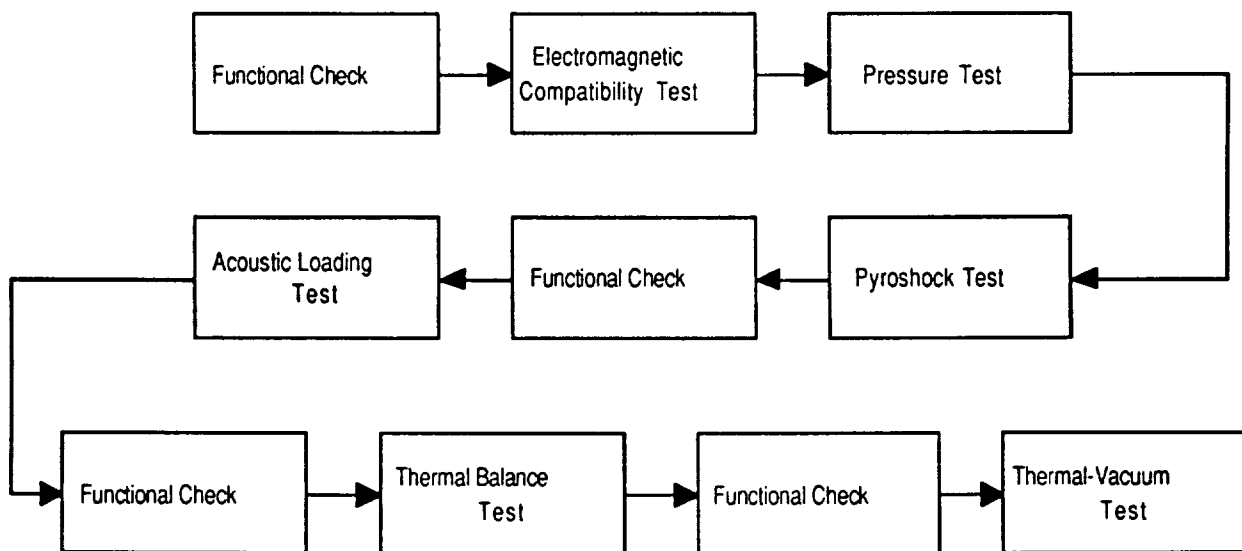

Figure B-10. RFC power system QU test sequence.

Task 9. Flight Unit (FU) System Program

Objectives: Fabricate the flight systems and acceptance test the FUs to demonstrate required performance. Deliver the flight systems and provide integration support for the FU with the payload and the launch vehicle.

Statement of Work: Fabricate, acceptance test, and assemble parts to produce the flight systems. Subject the systems to acceptance testing before shipment to the launch site. Use the same test facilities (vacuum chamber, vibration, acoustic) that were used for the qualification program for flight system acceptance testing. Finally, provide launch support activities to insure that the RFC FU meets its design and performance goals associated with integrated payload and launch systems.

The work is divided into the following subtasks:

Subtask 9.1 Flight Component Fabrication. Design, fabricate, inspect, and assemble the components and subassemblies required for the FUs, including all spare parts as required to support the flight system activities.

Subtask 9.2 FU Assembly, Test, and Payload Integration. Assemble and inspect the FUs. Acceptance test the FUs and ship to the launch site. Provide technical support for FU integration with the payload, launch vehicle, and launch support facilities.

Subtask 9.3 FU Launch Support. Provide FU launch support activities to insure that the FU meets its design and performance goals associated with the integrated payload and launch systems.

DEVELOPMENT SCHEDULE

The program starts with a conceptual system design task followed by preliminary system design. Development of the fuel cell stack, electrolysis cell stack, thermal management subsystem, water control subsystem, storage tanks, and PP&C proceed concurrently with the system design. The system design is subsequently completed by the middle of the fourth year.

Fabrication of components for the GES starts with procurement of long lead materials

and equipment in the first part of the third year. This leads to assembly of the system by the end of the fourth year.

The GES will be similar to a flight system but will have features such as additional instrumentation and readily removable components to expedite gathering of engineering data and to permit modification of components. It will be tested in a vacuum chamber under normal and off-normal design conditions. After this phase of testing, it will be partially disassembled, examined, refurbished as necessary, and put on life test for 20,000 hours (50% duty cycle).

The qualification phase includes design, fabrication, assembly, and qualification testing of individual components, and a complete system. The design effort will be minimal since it would involve only minor modifications to the GES design. An optional life testing of the QU may be done. This may be unnecessary after the component and GES life testing.

The flight phase of the program includes fabrication, assembly, and acceptance testing of the flight units and the associated safety analysis to obtain launch approval.

Component development was estimated to require 2-4 years of effort (Ref. B-14) without any life testing depending on the current technology readiness levels. Five years were required to develop and qualify the non-regenerative Shuttle alkaline fuel cells. It is felt that the required development effort for a PEM RFC will be longer due to the integration effort involved, the considerable amount of life testing required both on the component/subsystem level and system level, and the number of different applications (more than one module size may be required). The estimated DDT&E and production schedule for the PEM fuel cell and RFC is shown in Figure B-11. Development time was estimated to be 7 years.

REGENERATIVE FUEL CELL POWER SYSTEM TECHNOLOGY ROADMAP

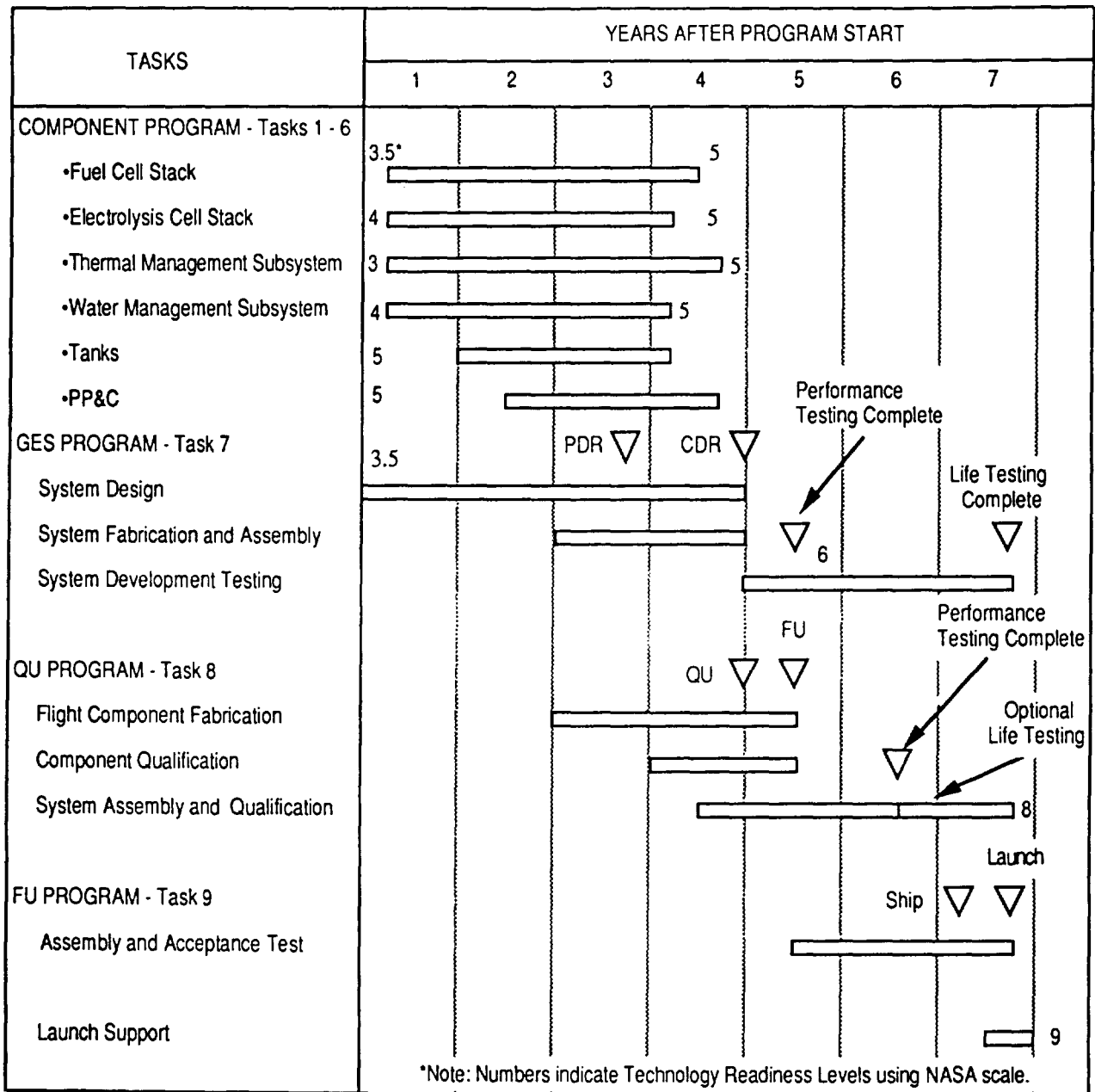

Figure B-11. PEM RFC power system development schedule.

REGENERATIVE FUEL CELL POWER SYSTEM TECHNOLOGY ROADMAP

REFERENCES

- B-1. Technology Assessment and Tradeoff Study of Fuel Cell and Electrolyzer Technology for Project Pathfinder Energy Storage System. Los Alamos National Laboratory, February 1991.
- B-2. McElroy, J.F.: SPE[®] Water Electrolyzers in Support of Mission From Planet Earth. Space Electrochemical Research and Technology Conference, NASA conference publication 3125, April 1991.
- B-3. McElroy, J.F.: SPE[®] Regenerative Hydrogen/Oxygen Fuel Cells For Extraterrestrial Surface Applications. 24th IECEC Proceedings, August 1989, pp. 1631-1636.
- B-4. McElroy, J.F.; et. al: SPE[®] Regenerative Hydrogen/Oxygen Fuel Cells For a Lunar Base Power System. 25th IECEC Proceedings, August 1990, Volume 3, pp. 143-148.
- B-5. Personal Communications with Jim McElroy at Hamilton Standard. Rockwell International (Rocketdyne Division), Frank Littman, 8/13/91 - 3/25/92.
- B-6. Pesaran, A.A.: Silica Gel Sorption Properties under Adiabatic Conditions. Solar Energy Research Institute report no. SERI/TR-252-2704, February 1986.
- B-7. Penny, T.R.; et. al: Capacity Degradation of Field-Tested Silica Gel Samples. Solar Energy Research Institute report no. SERI/TP-252-2741, June 1985.
- B-8. Personal Communication with Paul Prokopius at NASA Lewis Research Center. Rockwell International (Rocketdyne Division), Frank Littman, August 21, 1991.
- B-9. Personal Communications with Ian Devey of Structural Composites Industries. Rockwell International (Rocketdyne Division), Frank Littman, October 9, 1991.
- B-10. Srinivasan, S.; et. al: Recent Advances in Solid Polymer Electrolyte Fuel Cell Technology with Low Platinum Loading Electrodes. 24th IECEC Proceedings, Vol. 3, August 1989, pp. 1623-1629.
- B-11. Lawrance, R.J.; and Margiott, V.A.: Proton Exchange Membrane Fuel Cell Development. 24th IECEC Proceedings, Vol. 3, August 1989, pp. 1587-1591.
- B-12. Hirschenhofer, J.H.: Commercial Fuel Cell Technology Status. 26th IECEC Proceedings, August 1991, pp. 521-525.
- B-13. Meyer, A.P.: Status of Solid Polymer Fuel Cell Power Plant Development at International Fuel Cells Corporation. 24th IECEC Proceedings, August 1989, pp. 1619-1622.
- B-14. Personal Communications with Jay Stedman at International Fuel Cells. Rockwell International (Rocketdyne Division), Frank Littman, September 13, 1991.
- B-15. Juhasz, A.J.: An Overview of the LeRC CSTI Thermal Management Program. Paper no. AIAA-91-3528, AIAA/NASA/OAI Conference on Advanced SEI Technologies, September 4-6, 1991.
- B-16. Bock, E.H.; and Fisher, J.G.: In-Space Propellant Processing Using Water Delivered as Shuttle Contingency Payload. AIAA Paper 78-941, July 1978.

SODIUM SULFUR BATTERY TECHNOLOGY ROADMAP

APPENDIX C - NaS BATTERY TECHNOLOGY ROADMAP

INTRODUCTION

This is a family of power systems based on common technology for use with portable or mobile power systems. Mobile battery power systems are either incorporated into vehicles or are attached to vehicles as part of a separate power cart. These systems range in nominal power level from 3 to 22 kWe. These vehicles include the payload unloader (3 kWe normal [n]/10 kWe peak [p]), pressurized manned rover (7 kWe onboard, 12 kWe with power cart), regolith hauler (3 [n]/15 [p] kWe), and mining excavator (22 [n]/40 [p] kWe). Mobile Mars power systems will be similar to lunar systems except for the radiator size.

CONCEPT DESCRIPTION

A typical power system schematic is shown in Figure C-1. The overall power system may be divided into the following subsystems for development purposes:

- Batteries;
- Thermal Management; and
- Power Processing and Control (PP&C).

The energy to the user is supplied by the batteries. The batteries are recharged on the next sun cycle by the base power system or by a Dynamic Isotope System (DIPS) power cart. The flow of energy from the array and to and from the batteries is controlled by the PP&C subsystem.

Since the batteries must operate at high temperature, thermal management is required to maintain the proper cell temperature and reject waste heat. In addition, the batteries need to be heated prior to startup. The electronic components in the PP&C also require cooling to remove waste heat.

The battery subsystem includes the cells and related structure to tie the cells together.

The thermal management subsystem includes battery insulation, battery isolation plates, battery radiator/interface heat exchanger, PP&C cold plates, and the PP&C radiator.

SODIUM SULFUR BATTERY TECHNOLOGY ROADMAP

Power conditioning is included to process power for charging the batteries (down regulator) and processing output power (boost regulator). A shunt regular dissipates excess power from the array.

The system evaluated in this article uses sodium sulfur (NaS) batteries, DC-DC converters/regulators, and a heat pipe radiator. Each subsystem will be described in more detail in the following sections.

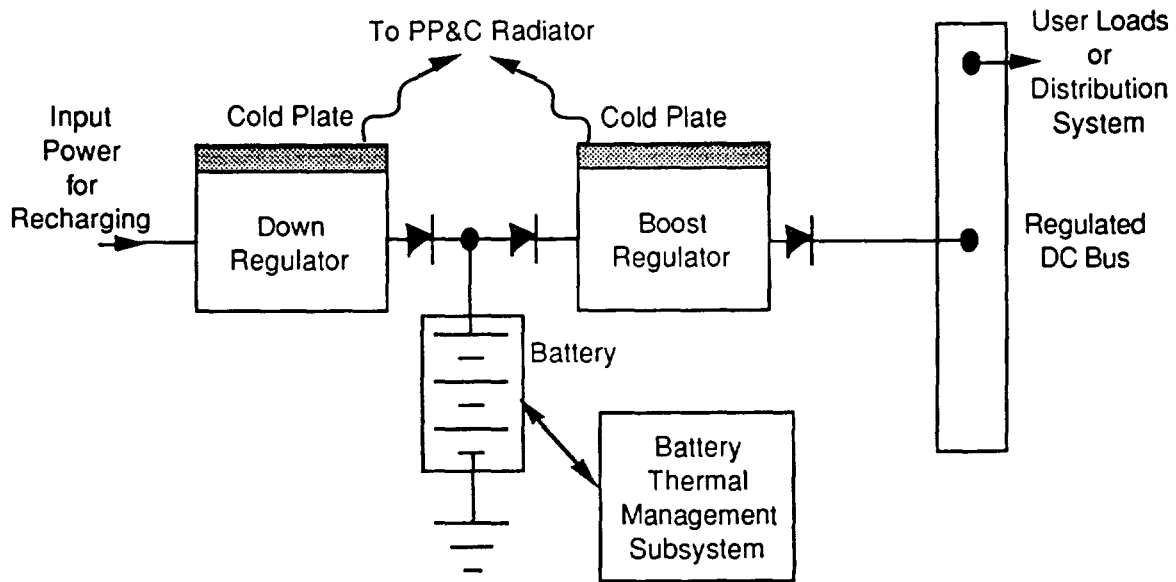

Figure C-1. Battery system schematic.

Battery Subsystem Description

Sodium sulfur batteries are high temperature (598 °K) secondary batteries which have been under development for a number of years. Due to the high theoretical specific energy, these batteries are being considered for electric vehicles, utility load leveling, satellite systems (Ref. C-1), and planetary surface power systems (Refs. C-2 and C-3).

A fully charged sodium sulfur cell consists of elemental sulfur and sodium separated by a beta alumina electrolyte as seen in Figure C-2. Beta alumina is a solid, ceramic electrolyte separator which is conductive only to sodium ions. The molten sodium serves as the negative electrode. During discharge, each sodium atom, entering into the discharge reaction, provides

SODIUM SULFUR BATTERY TECHNOLOGY ROADMAP

an electron to the external circuit and migrates through the electrolyte. The molten sulfur serves as the positive electrode. The sodium ions receive an electron, from the external circuit, on the sulfur side of the cell and combine with the sulfur to form sodium pentasulfide, Na_2S_5 . After all the free sulfur is combined, a second conversion takes place in which the Na_2S_5 is converted to sodium trisulfide, Na_2S_3 . The open circuit voltage of the cell during the first 59% of discharge, which corresponds to the sodium pentasulfide reaction, is nominally 2.08 volts per cell. During the sodium trisulfide part of the discharge, the corresponding voltage is 1.75 volts per cell. Thus, the sodium sulfur cell discharge voltage has a two level characteristic with the step change at about 59 percent. Experimental investigation has indicated that for best cycle life, the depth of discharge should be limited to 59 percent.

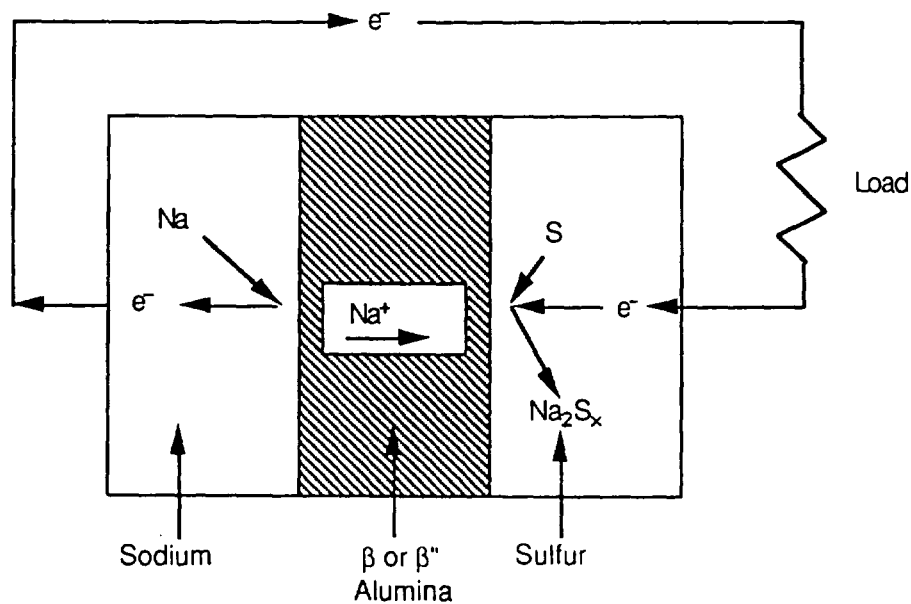

Figure C-2. NaS battery cell operation during discharge.

A tubular type NaS cell is illustrated in Figure C-3. This concept is most suitable for base load power systems (15 minutes to 12 hours of operation). These type of NaS cells have been

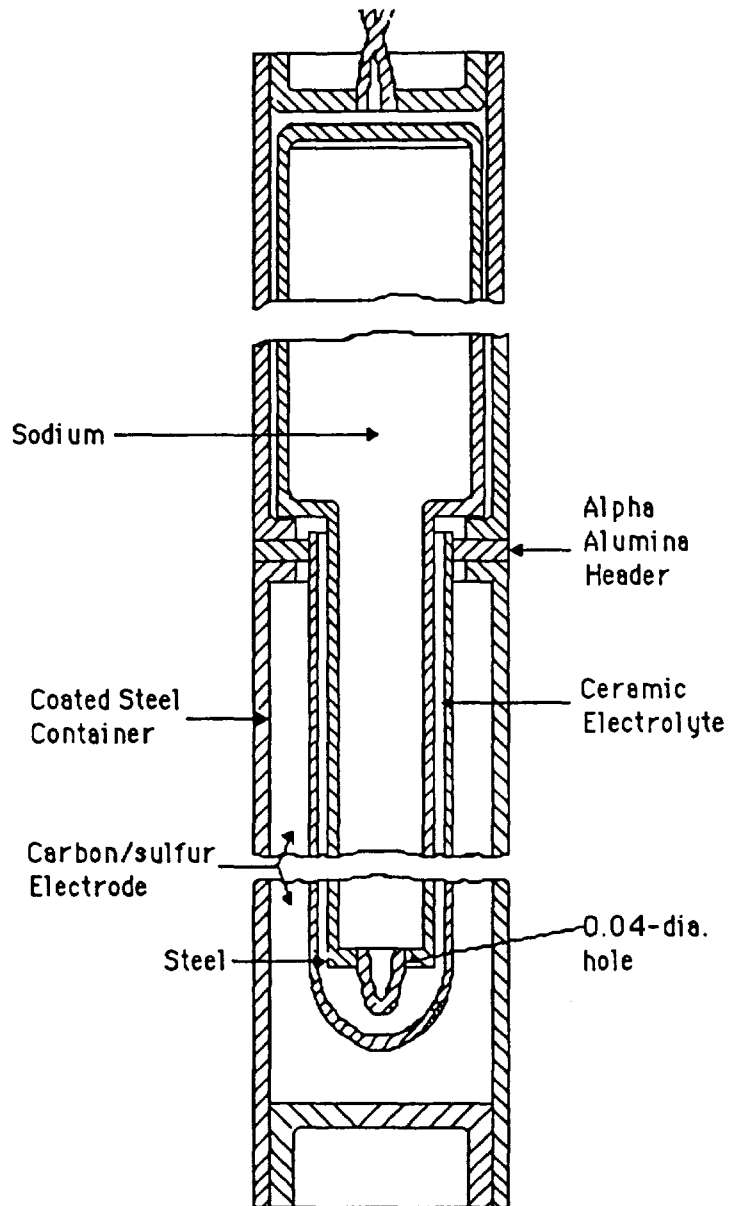

Figure C-3. Typical tubular NaS battery cell design.

undergoing evaluation testing by the Air Force for many years and have gone through several design iterations. As shown in the figure, the liquid sodium is contained in a closed steel tube with a metering orifice connecting to an annular chamber also containing sodium. The closed beta alumina electrolyte encloses the sodium and separates it from the liquid sulfur cathode. Liquid sulfur cathode material is held in a carbon felt matrix to provide electrical conductivity

during charge and discharge. The steel tube is coated with a metal chosen for its resistance to the corrosive sodium sulfides.

Thermal Management Subsystem Description

The thermal management subsystem provides temperature control, heat transport, and heat rejection functions. Solid conduction paths and heat pipes provide the heat transport function. A radiator is required to remove waste heat from the battery and from the PP&C components.

An active thermal control system is required to maintain the battery at the proper operating temperature. Three different techniques are possible for controlling battery temperature (Ref. C-4): (1) louvers; (2) pumped loop radiator; and (3) heat pipe radiator.

The use of louvers allows the battery to radiate directly to space as needed to reduce its temperature. Louvers offer the greatest weight advantage (Ref. C-4). However, louvers require the greatest mechanical complexity and potentially the lowest reliability. Louvers also allow for a nonhomogeneous thermal distribution in the battery which may be detrimental.

Pumped loop (or tube-sheet) radiators offer the next best approach from a mass standpoint if no redundancy is built into them. Pumped loop radiators have been used successfully for the space shuttle and will be used for Space Station Freedom (SSF). This type of radiator is best applied to missions with limited duration or to systems which are serviceable. Potential working fluids include water, potassium, NaK, and Dowtherm A. NaK is the preferred working fluid for this application due to its low freezing point, low operating pressure, and stability in a thermal environment. The use of NaK as a reactor primary coolant indicate that it can be used with good reliability for prolonged periods of time. The development of highly reliable, long life, low flow rate, low mass pumping systems to accommodate the use of fluid loops in space would require considerable effort (Ref. C-4). Furthermore, the pump represents the source of a single point failure mode, thus requiring duplication within the system and thereby nullifying the slight mass advantage over heat pipes.

Thermal homogeneity could be accomplished with heat pipe systems for transport and heat rejection due to their isothermal heat transport characteristics. Heat pipes also offer the advantage of improved reliability and a graceful failure mode. A recent Rocketdyne study has shown that advanced carbon-carbon (C-C) heat pipe radiators can be designed which are competitive in mass to pumped loop radiators (estimated specific mass of 3 kg/m² for heat pipes with water or ammonia). Thus, a heat pipe radiator was tentatively selected as the baseline design.

The baseline heat rejection assemblies utilize lightweight, passive, reliable, heat pipe radiators that are sufficiently versatile to allow integration into a variety of configurations. The individual heat pipes operate independent from one another and thus the failure of a heat pipe will not result in failure of the complete radiator. The rectangular radiator heat pipe panel is attached to the battery assembly. Variable conductance heat pipes transfer heat to the radiator. The heat pipe working fluid evaporates and travels to the top end of the heat pipes. The evaporated fluid is then condensed in the cooler section of the heat pipe. A small wick or grooves allow the liquid to return to the evaporator (unless the heat pipe is vertical and gravity can be used for fluid return). A wick or groove is not absolutely necessary for vertically oriented radiators (due to gravity return) but is recommended to insure good control of the fluid transport. The heat pipes may be either carbon-carbon tubes with metal liners (titanium or nickel based alloy for biphenyl) or metal heat pipes. Carbon-carbon heat pipes are a factor of 2-3 times lower in mass than conventional all-metal heat pipes.

The problem with using a heat pipe for battery cooling is that no common heat pipe working fluid is suitable for operation at about 600 °K (Ref. C-5). Only three of the common heat pipe working fluids including water, cesium, and mercury show any promise for operation at this temperature. However, these fluids have several disadvantages. Both mercury and cesium are highly toxic and would have handling problems. Mercury has a poor contact angle and does not wet the wick surface, which causes heat pipe priming problems. Mercury also has a high density which results in a heavy heat pipe. Cesium has a very low vapor pressure which

favors leakage into the pipe. Leakage is a severe problem since atmospheric water will react with the cesium to form hydrogen. Water develops a high pressure at the required operating pressure which requires a heavier heat pipe and may result in potential safety issues. A recent study (Ref. C-5) found that biphenyl is a suitable heat pipe working fluid for this application. Biphenyl is compatible with likely materials of construction and its liquid transport factor is suitable for use in a heat pipe. Also, its vapor pressure is in the desired range at the operating temperature of the battery. Thermal studies have shown that biphenyl should be stable for long-term operation at high temperature and non-condensable gas generation will not be a problem. Thus, biphenyl was selected as the working fluid for the battery heat pipes.

PP&C Subsystem Description

The PP&C subsystem is a collective term for the power system control electronics. This system includes items such as voltage regulators and battery charge controllers. Their function is to control the flow of energy through the power system to the payload.

Boost Regulator Description. The boost regulator increases the voltage from the batteries up to the nominal bus voltage. There are two basic types of boost regulators. The basic boost regulator handles all of the processed power and the efficiency of the circuit applies to all the power. This regulator places a "buck" inductor and switch in alternate positions such that the opening switch allows the inductor to force the current it had before the switch opened into the load impedance. The output voltage depends on the load impedance and current. The basic booster has a relatively low efficiency and may have loop stability problems.

The add-on booster only processes the boost voltage (usually only 10 volts). The boost power (voltage added times output current) is parallel to the load at the input. Most of the power is not processed and thus the overall efficiency is much higher than for the basic boost regulator. A failure of the add-on booster results in a lower DC bus voltage, but the system is still functional with degraded performance.

The boost regulator requires monitoring equipment to determine operating parameters and heat sinking to remove waste heat. EMI filters are required to prevent interference from the switching.

Down Regulator Description. The charging power system (especially in the case of a PV array) will be designed to provide a higher voltage than the nominal battery voltage. The down or "buck" regulator provides a constant output DC voltage for charging the battery subsystem from the array. The regulator output voltage is always lower than the input voltage. The voltage conversion is accomplished by switching the input on and off. The filter removes the AC component produced by switching, but allows the DC voltage through.

The down regulator is reliable and very efficient (85-90% for nearterm hardware). The efficiency of the regulator depends on the internal operating frequency and the input-output voltage difference. As the frequency goes up the size goes down and so does the efficiency. This regulator does not isolate the input from the output loads. If the regulator is not properly used, then it can cause radio interference since it uses switching to interrupt the current. Proper EMI filters are required to eliminate this interference. Monitoring equipment is required to determine the proper operating conditions. Heat sinking is required to remove waste heat.

TECHNOLOGY ISSUES

The key issues for development of a NaS battery subsystem are summarized in Table C-1. The key issue with sodium sulfur batteries is achieving cycle life to permit operation as a satellite battery. While the specific energy, of the sodium sulfur system, is much higher than the current baseline nickel hydrogen batteries, the cycle life is much lower. Primary failure mechanisms are related to corrosion of the seals and cell components by the chemically active sulfides and the fragility of the beta alumina electrolyte. Design features have been developed to mitigate the effect of these failure mechanisms so that a failure is not catastrophic. Cracking of the electrolyte or loss of cell case integrity does however, result in loss of the cell however.

SODIUM SULFUR BATTERY TECHNOLOGY ROADMAP

Continuing cell development is aimed at resolving these issues.

TABLE C-1. NaS BATTERY SUBSYSTEM ISSUES, IMPACTS, AND DEVELOPMENT AREAS

Issues	Impacts	Potential Development Areas
Cycle life	•Increased life cycle cost	•Physical and chemical stability of alpha alumina seal •Physical and chemical stability of electrolyte •Sealing technology for tubesheet to cell case
High operating temperature	•Heavy heat pipes, poor performance, toxic working fluids (cesium or mercury) or high pressure (water)	•Low mass C/C heat pipe radiator •Heat pipe working fluids (biphenyl)
Safety (explosion, fire, toxic fumes, formation of sulfuric acid)	•Increased manufacturing cost	•Battery casing design

TECHNOLOGY ASSESSMENT

The technology bases were assessed for the following major battery subsystems:

- Batteries;
- Thermal management; and
- PP&C.

The technology readiness of each assembly was evaluated using the NASA technology readiness levels. These evaluations are summarized in Table C-2 which shows that the power system has technology readiness levels ranging from 3 to 5, depending on the particular subsystem. The technology base for subsystems is discussed in the following sections.

TABLE C-2. NaS BATTERY TECHNOLOGY ASSESSMENT

Subsystem	Technology Readiness Level	Comments
NaS batteries	4	Breadboard cells tested by Air Force and prototype battery is under development
Battery thermal management	3	Radiator component development currently underway; biphenyl investigated as heat pipe fluid
PP&C	5	Similar components under development for Space Station Freedom (SSF)

System State-of-the-Art

The NaS battery system has a NASA Level of about 3.5. The concept of this type of a system has been formulated but the details of the system have not been worked out. Specifically, this includes the integration of the NaS battery storage into the system. Though NaS batteries are a basic secondary type battery they require special thermal control to work. The batteries require an operating temperature of 598 °K. The PP&C subsystem will have to work in conjunction with thermal control system to maintain this temperature. In addition, to overcome the fragility problems of NaS batteries, it has been proposed to launch the batteries in a frozen state (<573 °K). Once on the planetary surface, the batteries will have to be brought up to temperature through some type of external source. For a flight test experiment, the power source will be the Shuttle payload power bus. Another issue is that prior to the time the NaS batteries are brought on line the spacecraft will need power for basic operations such as ground telemetry and array deployment. Some other source of energy, such as a primary battery, will be necessary and will increase the complexity of the PP&C subsystem. In this system the operational characteristics of the NaS battery are the key issues. Due to the low readiness level of the NaS battery and the thermal management subsystem, the overall system readiness level is relatively low compared to current battery systems.

Battery Subsystem State-of-the-Art

Development of sodium sulfur batteries was initiated in the 1960s for electric vehicle applications (Ref. C-6). Since then, development has progressed to the point that prototypes and breadboards are now being fabricated or are in test. Advancement of the technology has been limited by the low level of funding and the concern over the safety and operating temperature of the battery. Several manufacturers are engaged in ceramics development on the electrolytes and, in the United States, Hughes and Eagle-Picher are actively engaged in the development of space type batteries (Ref. C-7).

Eagle-Picher, in conjunction with Hughes Aircraft, had an Air Force contract

(administered by WPAFB) which ran from 9/86 to 1/91 to develop a NaS cell for Low Earth Orbit (LEO). The major goals of this program were the following:

- specific energy of 50 W-hr/lb;
- 30,000 charge-discharge cycles;
- 2C discharge rate;
- 5 year calendar life; and
- withstand LEO environment.

A Mars surface environment would be much more benign for a battery subsystem than a LEO application due to a reduced charging rate, a reduced number of cycles (only 1825 for 5 years), and a gravity environment (poor distribution of reactants in microgravity environment can cause current blockage due to formation of a non-conductive layer). In addition, the battery can be qualified using only ground testing.

For space applications, NASA Level 4 would apply. That is, breadboard cells have been in test for some time by the Air Force and a prototype of a satellite battery is in development under Air Force contract and is to be demonstrated in 1993 or 1994 (Ref. C-1). Further development is required to accelerate the fabrication and testing of cells and batteries in order to identify currently unknown problem areas. Specifically, testing will include space environmental testing, materials compatibility testing, and cycle testing. Under current funding levels, flight test of the battery is projected for the 1996 to 1997 timeframe. Availability for space applications is projected for the year 2000.

Thermal Management Subsystem State-of-the-Art

NASA LeRC is currently carrying out an integrated multi-element project for the development of space heat rejection subsystems with special emphasis on low mass radiators in support of SEI power system technology (Ref. C-8). This effort involves both in-house and contracted efforts. Contracted efforts involving Rockwell International (RI) and Space Power Incorporated (SPI) are aimed at the development of advanced radiator concepts (ARC). NASA

SODIUM SULFUR BATTERY TECHNOLOGY ROADMAP

LeRC is also involved in a joint program with DOE to demonstrate a flexible fabric heat pipe radiator concept being developed by Pacific Northwest Laboratories (PNL). In-house work at NASA LeRC is designed to guide and support the overall program by system integration studies, heat pipe testing and analytical code development, radiator surface morphology alteration for emissivity enhancement, and composite materials research focused on the development of low mass, high conductivity fins. This program is concentrating on technologies capable of development before the end of the decade for both surface power and nuclear electric propulsion (NEP) applications.

Specific objectives of the ARC contracts are to achieve specific mass values $<5 \text{ kg/m}^2$ with radiator surface emissivities of 0.85 or higher at typical radiator operating temperatures, and reliability values of at least 0.99 for the heat rejection subsystem over a ten year life. These figures represent a factor of two improvement over the currently considered heat rejection subsystem for SP-100, and even greater improvement factors for state-of-the-art heat rejection systems used in current spacecraft applications.

Presently, Rocketdyne division of Rockwell International is involved in the development of a carbon-carbon (C-C) or graphite heat pipe radiator panel. Rocketdyne has a NASA contract entitled "SP-100 Advanced Radiator Concepts" which started in 1987 and is part of the CSTI (Civilian Space Technology Initiative) program. This program will be completed in January of 1993. This program involves development of a C-C heat pipe suitable for use in an SP-100 radiator. However, this technology will be suitable for other radiator applications as well including battery power systems (using other working fluids). The hope is that this program will develop generic technology which can be used for all future space radiators because of its reduced mass compared to metal heat pipe radiators. Carbon-carbon is a new structural material which requires different fabrication techniques than for metals or composites. A key objective of this program is to demonstrate the ability to fabricate C-C heat pipes with a thin metal liner, wicks, caps, and fill tube. The brazing technique required to attach liners is the same as would be required to attach manifolds to the heat pipes. Heat pipes filled with potassium

will be designed, fabricated, and tested during this program. Thermal cycle testing will be done in a vacuum to demonstrate the integrity of the heat pipes.

Beginning in 1989, small samples of heat pipe panels were fabricated by Rocketdyne as part of the CSTI program. The next phase of the program will involve fabrication and testing of complete heat pipes several feet long.

The working fluids and temperatures for the SP-100 system would be different than for lower temperature battery systems. Thus, Rocketdyne has an on-going IR&D effort which involves development of a C-C heat pipe for lower temperature applications. This effort will eventually include fabrication and testing of a heat pipe. Rocketdyne is also looking at a higher thermal conductivity C-C heat pipe design.

The objective of the joint NASA LeRC/Air Force program with PNL (Light Weight Advanced Ceramic Fiber [ACF] Heat Pipe Radiators) is to demonstrate the feasibility of a low mass ceramic fabric/metal liner heat pipe for a wide range of operating temperatures and working fluids (Ref. C-8). Specifically, the NASA LeRC objectives are to develop this concept for application to space radiators with operating temperatures below 500 °K using water as the working fluid. The specific mass goal for these heat pipes is 3 kg/m² or less at a surface emissivity of greater than 0.85.

Several heat pipes were built for the ACF program using titanium and copper foil material for containment of the water working fluid. A heat pipe with an 0.2 mm Ti liner was demonstrated in early January 1991. An innovative "Uniskan Roller Extrusion" process has also been developed at PNL and used to draw 0.76 mm wall tubing to a 0.05 mm foil liner in one pass. The water heat pipes fabricated for LeRC have been subjected to a test program to evaluate performance and reliability at demanding operating conditions.

Future thrusts of the ACF program will be to perfect the heat pipe fabrication procedure using very thin (0.025 to 0.05 mm) foil liners which are internally texturized by exposure to high pressures (Ref. C-8). Plans will also be developed to perform hyper-velocity and ballistic velocity impact tests in order to determine if secondary fragments from a penetrated

heat pipe will result in failures of neighboring heat pipes. Another major challenge will be to design a heat pipe with high conductivity, low mass fins as a first step toward the fabrication of low mass radiator panels.

The NASA LeRC in-house materials program includes radiator surface morphology alteration by arc texturing for emissivity enhancement purposes (Ref. C-8). Emissivity enhancement has been demonstrated for graphite-copper samples.

PP&C State-of-the-Art

Assigning a NASA Readiness Level to PP&C is difficult. There are many systems that have flown which would make parts of the PP&C subsystem Level 9, but each PP&C system was custom design for each spacecraft design. Only until recently has the array and battery PP&C become standardized into packaged systems. In the Space Station Freedom program, standard PP&C components are undergoing qualification. Recent military programs have ended with qualified packaged PP&C component designs.

The PP&C system design is based on a reasonable electronics component evolution, and there are no significant technology issues associated with its development. It will be necessary to fabricate breadboard hardware for testing and evaluation purposes, but there is no need to initiate any advanced component development. Most of the hardware elements have been or shortly will be operating in a relevant environment on other spacecraft or the SSF electrical power subsystem.

DEVELOPMENT PLANS

The development program was divided into six major tasks. The first three tasks are component development tasks. The last three tasks includes the system design, fabrication, integration, and testing for the Ground Engineering System (GES), Qualification Unit (QU), and Flight Unit (FU).

Testing will be done on the component, subsystem, and system level (qualification

testing). The system level tests will show any possible negative interactions between subsystems.

The battery development tasks are described in the following sections. Each task will include a section on objectives and the statement of work.

Task 1. Battery Subsystem Development

Objectives: Develop a full scale flight weight battery module. Demonstrate materials compatibility, safety and performance margins.

Statement of Work: This effort was divided into the following subtasks:

Subtask 1.1 Preliminary Battery Development. Demonstrate the feasibility of the selected battery design for planetary surface applications. Test a prototype battery to demonstrate materials compatibility, safety, and component life.

Subtask 1.2 Final Battery Module Design. Design a full scale flight weight battery module.

Subtask 1.3 Battery Module Fabrication, Assembly, and Testing. Build and test (performance, mechanical, and thermal cycling) the battery module. After initial breadboard validation testing is complete, perform additional module testing in a relevant environment.

Task 2. Thermal Management Subsystem Development

Objectives: Develop and demonstrate a low mass, reliable heat pipe radiator which will operate at about 600 °K. Develop and demonstrate components for thermally isolating the battery from the rest of the system and the environment. Develop a thermal management approach for the PP&C components.

Statement of Work: This effort was divided into the following subtasks:

Subtask 2.1 Heat Pipe Demonstration. Fabricate and test representative length heat pipes to fully characterize heat pipe performance. Compare test results with predicted performance over the anticipated range of operating conditions including startup, shutdown, and

restart.

Perform limited life testing of the heat pipes. Identify deterioration mechanisms, measure deterioration rates, and assess the adequacy of assembly and cleaning procedures. Withdraw heat pipe samples sequentially throughout the test period. Drain, section, and analyze the samples for corrosion, carbon diffusion, braze stability, and any other signs of deterioration.

In conjunction with the heat pipe performance and life testing, develop and demonstrate techniques for nondestructive examination (NDE) of the heat pipe elements and assembly. Assess the adequacy of liner bonding and weld joints. Determine if the correct fit-ups and interfaces were obtained in the assembled piece.

Subtask 2.2 Radiator Enhancement. Increase the applicability of the radiator concept by performing various enhancement tasks. Examine survivability options and extended length heat pipes.

Perform analytical assessment, testing, and enhancement design development to insure long life for Mars missions. Consider natural threats such as micrometeoroids and dust erosion.

Fabricate a long heat pipe. Develop alternate techniques for fitting the liner into the tube. Investigate alternative tube fabrication, liner fabrication, and coating processes.

Subtask 2.3 Heat Pipe Integration and Testing. Develop and demonstrate techniques for attaching the heat pipes to the battery assembly. Subsequently, demonstrate heat pipe integration into a representative radiator section. Test the radiator section to provide an accurate overall heat transfer coefficient. Verify radiator dynamics and performance. Test the assembled unit in a cold wall, vacuum chamber, simulated space environment. Validate temperature drop predictions and assess component interactions.

Subtask 2.4 Thermal Management Subsystem Design, Assembly, Fabrication, and Testing. Develop the detailed design of the thermal management subsystem. Resolve specific design issues such as the effects of differential thermal expansion, deployment features, monitoring instrumentation and control equipment, local insulation, and trace heating of the

battery for thawing.

Design, fabricate, and test a representative full scale thermal management subsystem. Complete performance, mechanical (stress, shock, and vibration), and thermal cycling.

Task 3. PP&C Subsystem Development

Objectives: Demonstrate adequate steady state and transient performance, and immunity to the environment (including launch and operating). Demonstrate the software capability to handle power system nominal operation and failure modes.

Statement of Work: This effort was divided into the following subtasks:

Subtask 3.1 Electrical Components. Build breadboard units to demonstrate and check functional performance of the individual component circuit designs. Incorporate any necessary design modifications and improvements into brassboard units. Verify functional performance within the constraints of the actual component configuration. Fabricate prototype units and perform a series of tests using simulated input and output loads. Test the controller to validate the operating system software. Include the following testing:

- start up, steady state and transient control;
- failure simulation and detection and switching;
- effects of temperature extremes and thermal shock;
- effects of environment;
- shock and vibration;
- cold plate heat loads; and
- EMI generation and susceptibility.

Subtask 3.2 Software - Check out the controller software using simulated inputs and outputs.

Task 4. Ground Engineering System (GES) Testing

Objectives: Design a system concept which will meet Mars power system applications. Show

the concept feasibility. Verify adequate performance and life for an integrated system.

Statement of Work: This effort was divided into the following subtasks:

Task 4.1 GES Design. Identify and characterize specific power system applications. Determine power system requirements. Define optimum power system module size based on trade studies which minimize the overall life cycle cost of the power system for all applications (trade between development cost and mass).

Identify concepts and perform tradeoff studies (performance, reliability, risk, safety, and life cycle cost) to select the optimum system design. Complete feasibility studies for the selected concept. Definitize the remaining hardware development tasks based on the system concept chosen.

Design a complete power system to at least meet the minimum life requirement (10 years for arrays and 5 years for batteries). Perform both design point and transient analyses to verify the design. Perform this task in parallel with the component development tasks to insure proper system characteristics

Task 4.2 GES Performance Tests. Manufacture the GES components and assemble. Pressure and leak check the assembly, fill the batteries and heat pipes, complete a electrical check-out, and check out all active devices to the extent possible.

Design the test program for the GES to verify all performance characteristics of the unit in conjunction with subjecting the GES to acceptance level tests. Conduct performance and thermal vacuum tests during a single thermal vacuum test sequence to demonstrate technical capabilities while minimizing program cost. Complete the following performance testing activities:

- checkout and refine subsystem assembly procedures;
- verify operation of ground support equipment (GSE) and interfaces with the GES;
- verify start up capability;
- verify steady state performance characteristics;
- establish effective operating range of the system;

SODIUM SULFUR BATTERY TECHNOLOGY ROADMAP

- check out software and verify autonomy (include all operational modes and simulate failure modes);
- simulate normal switchover from one module to another;
- simulate failures to trigger module switchover; and
- establish system sensitivity to off-normal conditions such as: (1) partial loss of radiator cooling, (2) varying radiator heat removal profile, (3) partial loss of electronic cooling, and (4) temporary losses of heat sink with varying duration.

Task 4.3 GES Life Test. Refurbish the GES after completion of performance, acceptance, and margin tests. Refurbishment will include the following:

- replacing or repairing components as necessary to ensure that the GES is returned to its as-built condition;
- addition of special instrumentation required for the life test phase; and
- modification of the main radiator heat removal system or replacement of the main radiator with a dump heat exchanger.

Install instrumentation to provide a comprehensive diagnosis of the "health" of the GES and to monitor for degradation of major assemblies and individual components. Place the GES on a multiyear life test in air. Operate the GES at its nominal operating point, with expected GES variations in power output and environment.

Disassemble the GES for diagnosis at the end of the life test. Determine areas to be examined by an analysis of the health monitoring data and from the reliability analysis predictions.

Task 5. Qualification Program Testing

Objectives: Fabricate the qualification units (QUs). Verify adequate performance and life for the QUs.

Statement of Work: Develop a comprehensive performance and dynamic testing program which will provide a formal demonstration that the power system will perform as designed after being subjected to simulated launch conditions. Select launch environmental conditions which envelope the probable intensities developed by various launch scenarios.

Begin the qualification effort (a typical approach is shown in Figure C-4) by qualifying the assemblies. Fabricate and assemble the qualified production items into the QU. Qualify the QU by the rules for space vehicle qualification.

This effort was divided into the following subtasks:

Subtask 6.1 Qualification Performance Testing. Conduct performance testing at each level to verify that each item performs as designed. Perform dynamic testing to verify the capability of the power system to withstand launch loads, including acoustic, pyroshock and vibrational. A possible performance and dynamic qualification test sequence for components and assemblies is shown in the matrix of Figure C-5. The corresponding qualification test sequence for the QU is shown in Figure C-6.

Subtask 6.2 Qualification Life Testing (Optional). After completion of the qualification performance testing, partially disassemble the QU and examine the unit. Refurbish the QU as required and modify for endurance testing in air, as described for the GES. Life test the QU.

Task 6 Flight Unit (FU) System Program

Objectives: Fabricate the flight systems, develop a flight safety program, and acceptance test the FUs to demonstrate required performance. Deliver the flight systems and provide integration support for the FU with the payload and the launch vehicle.

Statement of Work: Fabricate, acceptance test, and assemble parts to produce the flight systems. Subject the systems to acceptance testing before shipment to the launch site. Use the same test facilities (vacuum chamber, vibration, acoustic) that were used for the qualification program for flight system acceptance testing. Finally, provide launch support activities to insure that the FU meets its design and performance goals associated with integrated payload and launch systems.

The work is divided into the following subtasks:

Subtask 6.1 Flight Component Fabrication. Design, fabricate, inspect, and assemble

the components and subassemblies required for the FUs, including all spare parts as required to support the flight system activities.

Subtask 6.2 FU Assembly, Test, and Payload Integration. Assemble and inspect the FUs. Acceptance test the FUs and ship to the launch site. Provide technical support for FU integration with the payload, launch vehicle, and launch support facilities.

Subtask 6.3 FU Launch Support. Provide FU launch support activities to insure that the FU meets its design and performance goals associated with the integrated payload and launch systems.

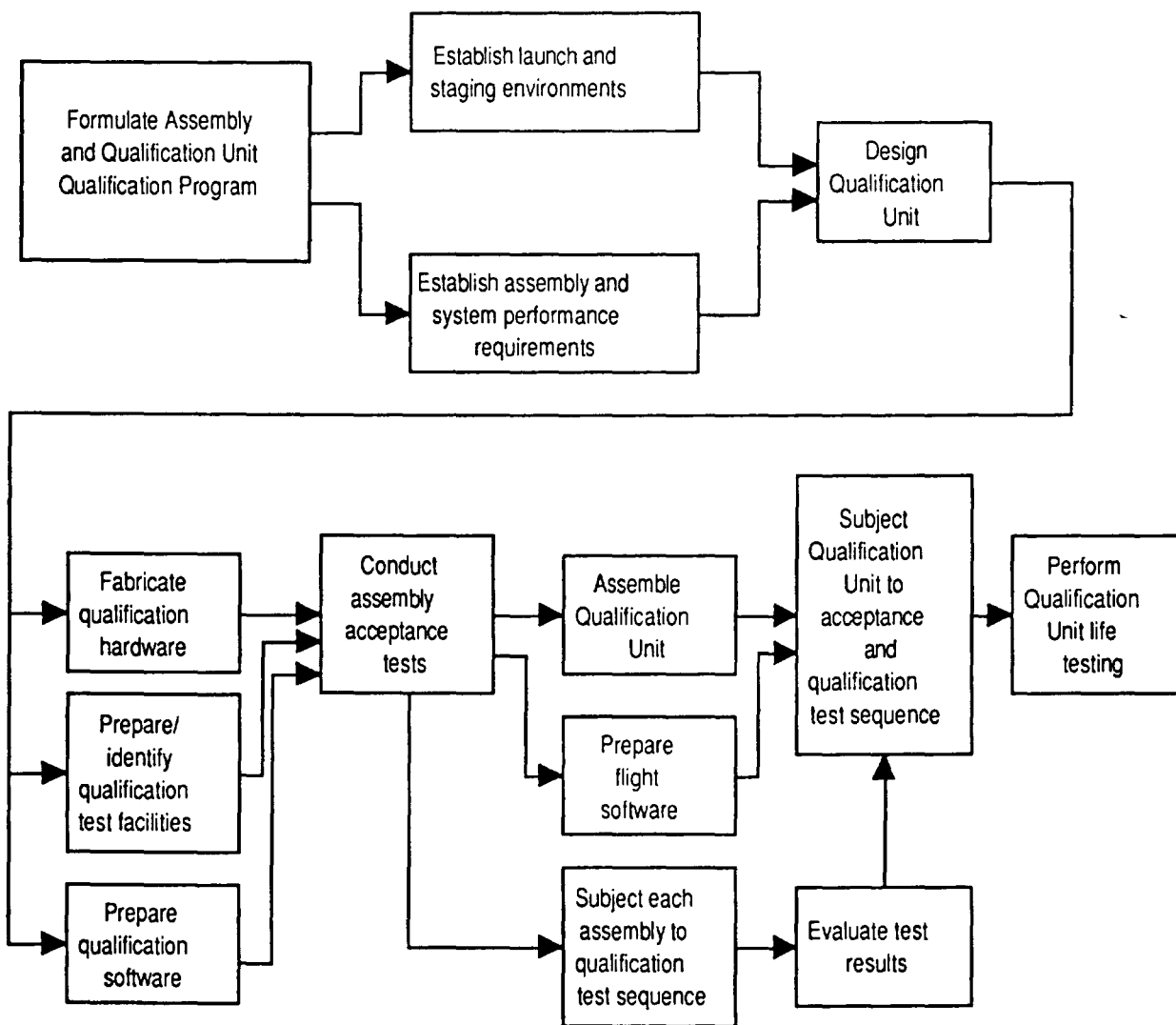

Figure C-4. NaS battery power system qualification program.

SODIUM SULFUR BATTERY TECHNOLOGY ROADMAP

Component or Subassembly	Functional (1)	Leak	Pyroshock	Functional (2)	Random Vibration	Functional (1)	Leak	Acceleration	Functional (1)	Thermal Cycling	Functional (2)	Thermal Vacuum	Functional (2)	Pressure	Leak	EMC	Life	Functional (1)
Battery Module	X	X			X	X	X			X	X	X	X	X	X	X	X	X
Radiators	X	X			X	X	X			X	X	X	X	X	X		X	X
PP&C	X		X	X	X	X				X	X	X	X			X	X	X
Structure	X		X	X	X	X		X	X	X	X						X	X

Figure C-5. NaS battery assembly qualification test matrix.

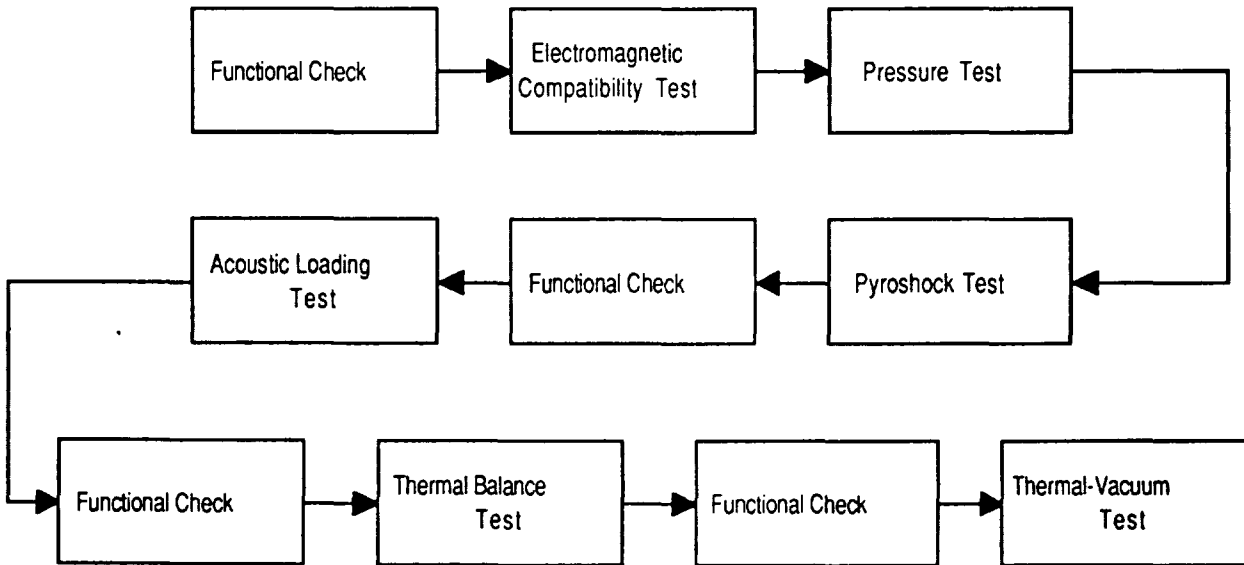

Figure C-6. QU test sequence.

DEVELOPMENT SCHEDULE

The program starts with a conceptual design task followed by preliminary design and concurrent component development or production of the battery, thermal management, and PP&C. The detailed design is subsequently completed by the middle of the third year.

Fabrication of components for ground testing for the Ground Engineering System (GES) starts with procurement of long lead materials and equipment in the first part of the fourth year. This leads to assembly of the system by the end of the fifth year.

The GES will be similar to a flight system but will have features such as additional instrumentation and readily removable components to expedite gathering of engineering data and to permit modification of components. It will be tested in a vacuum chamber under normal and off-normal design conditions. After this phase of testing, it will be partially disassembled, examined, refurbished as necessary, and put on life test, nominally for 1 year.

The qualification phase includes design, fabrication, assembly, and qualification testing of individual components, and a complete system. The design effort will be minimal since it would involve only minor modifications to the GES design.

The flight phase of the program includes fabrication, assembly, and acceptance testing of the flight units and the associated safety analysis to obtain launch approval.

The estimated development and production schedule for the power system is shown in Figure C-7. A minimum development time is about 8 years.

SODIUM SULFUR BATTERY TECHNOLOGY ROADMAP

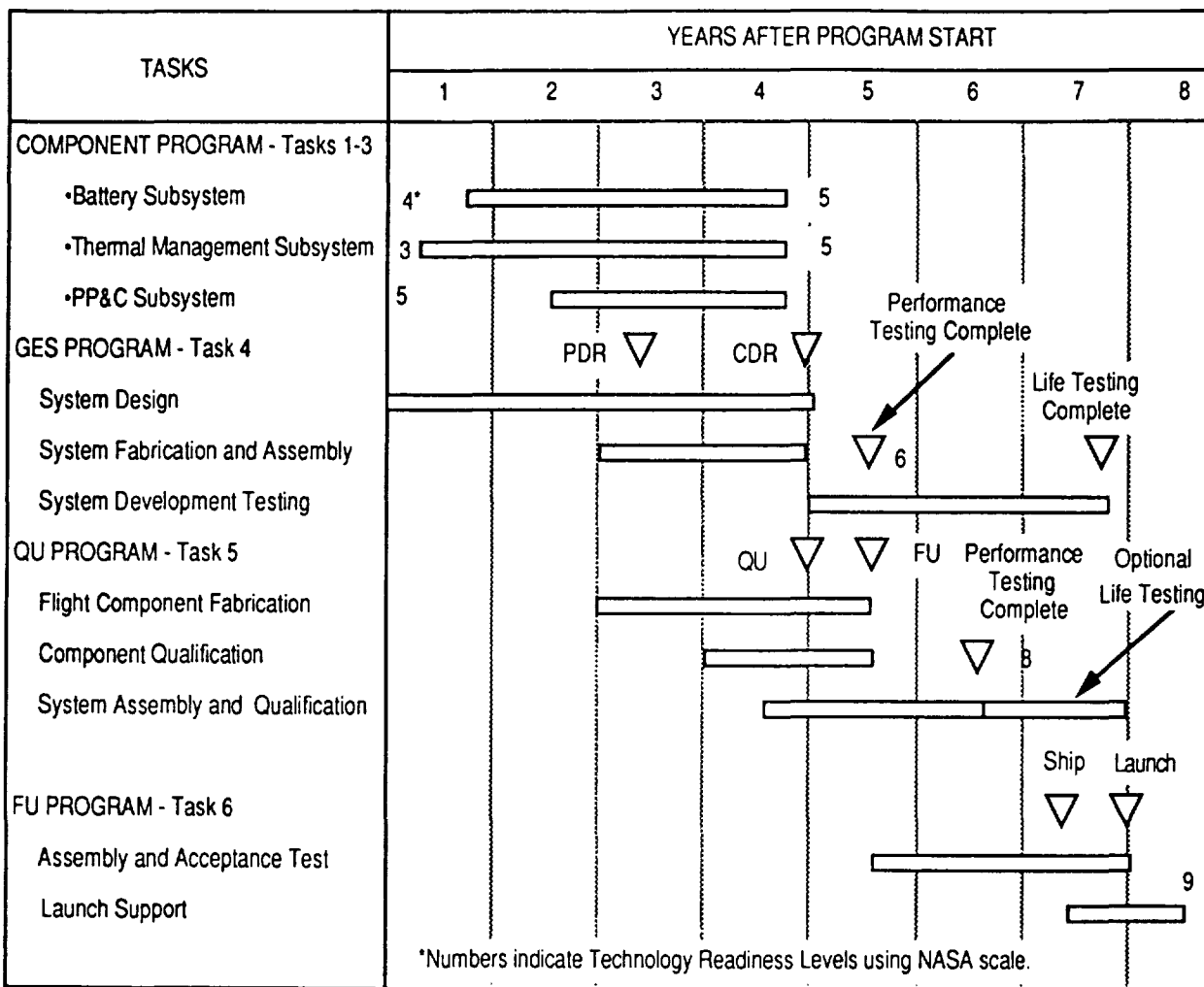

Figure C-7. NaS battery power system development schedule.

REFERENCES

- C-1. High Energy Density Rechargeable Battery, Preliminary Design Review. Hughes Aircraft Company briefing, 27 April 1988.
- C-2. Petri, D.A.; Cataldo, R.L.; and Bozek, J.M.: Power System Requirements and Definition for Lunar and Mars Outputs. 25th IECEC proceedings, Vol. 1, August 1990, p. 18.
- C-3. Withrow, C.A.; et al: SEI Rover Solar-Electrochemical Power System Options. 26th IECEC, August 1991, p. 319.
- C-4. Marcoux, L.; and Allen, D.M.: Conceptual Design of a Large Spacecraft Power System Utilizing a Sodium-Sulfur Battery. IECEC'83, Vol. 4, August 1983, p. 1470.
- C-5. Grzyll, L.R.: Investigation of Heat Pipe Working Fluids for Thermal Control of the Sodium/Sulfur Battery. 26th IECEC proceedings, Vol. 3, p.1390.
- C-6. Linden, D.: Handbook of Batteries and Fuel Cells. McGraw Hill Book Company, 1984.
- C-7. Taenaka, R.: Personal Communications. Hughes Aircraft Co., 19 February 1992.
- C-8. Juhasz, A.J.: An Overview of the LeRC CSTI Thermal Management Program. Paper no. AIAA-91-3528, AIAA/NASA/OAI Conference on Advanced SEI Technologies, September 4-6, 1991.

APPENDIX D

INTRODUCTION

This is a family of fixed power systems for both lunar and Mars applications. Mission applications require power levels from 0.9 kWe to 25 kWe (up to 100 kWe for lunar applications). Power system applications include communications (0.9 kWe), the excursion vehicle servicer (10 kWe), emergency power (12 kWe), and exploration site main power (25 kWe for habitat and associated external equipment). Solar powered systems such as these will require energy storage for operation at night.

CONCEPT DESCRIPTION

A typical power system schematic is shown in Figure D-1. The overall power system may be divided into the following subsystems for development purposes:

- Photovoltaic (PV) Array;
- Regenerative Fuel Cell (RFC);
- Radiator; and
- Power Processing and Control (PP&C).

The solar array converts sun light directly into DC electricity. The energy from the array flows to the electrolysis cells to electrolyze water and to the user. When the system enters a period of darkness, the energy to the user is supplied by the fuel cells. The electrolysis process is repeated on the next sun cycle. The flow of energy from the array and to and from the RFC is controlled by the PP&C subsystem.

The PV subsystem includes the array panels, support structure, and wiring harness. For development purposes, specific subtasks will include cell development, array development, deployment development, and integration/ system testing. This power system concept utilizes high efficiency multijunction tandem photovoltaic cells to minimize array area. A large array area is required for Mars applications due to the low insolation rate (due to dust from local and

global dust storms). Since the PV subsystem is the largest component of system mass for Mars systems, it is important to minimize array area and specific mass (kg/sq m).

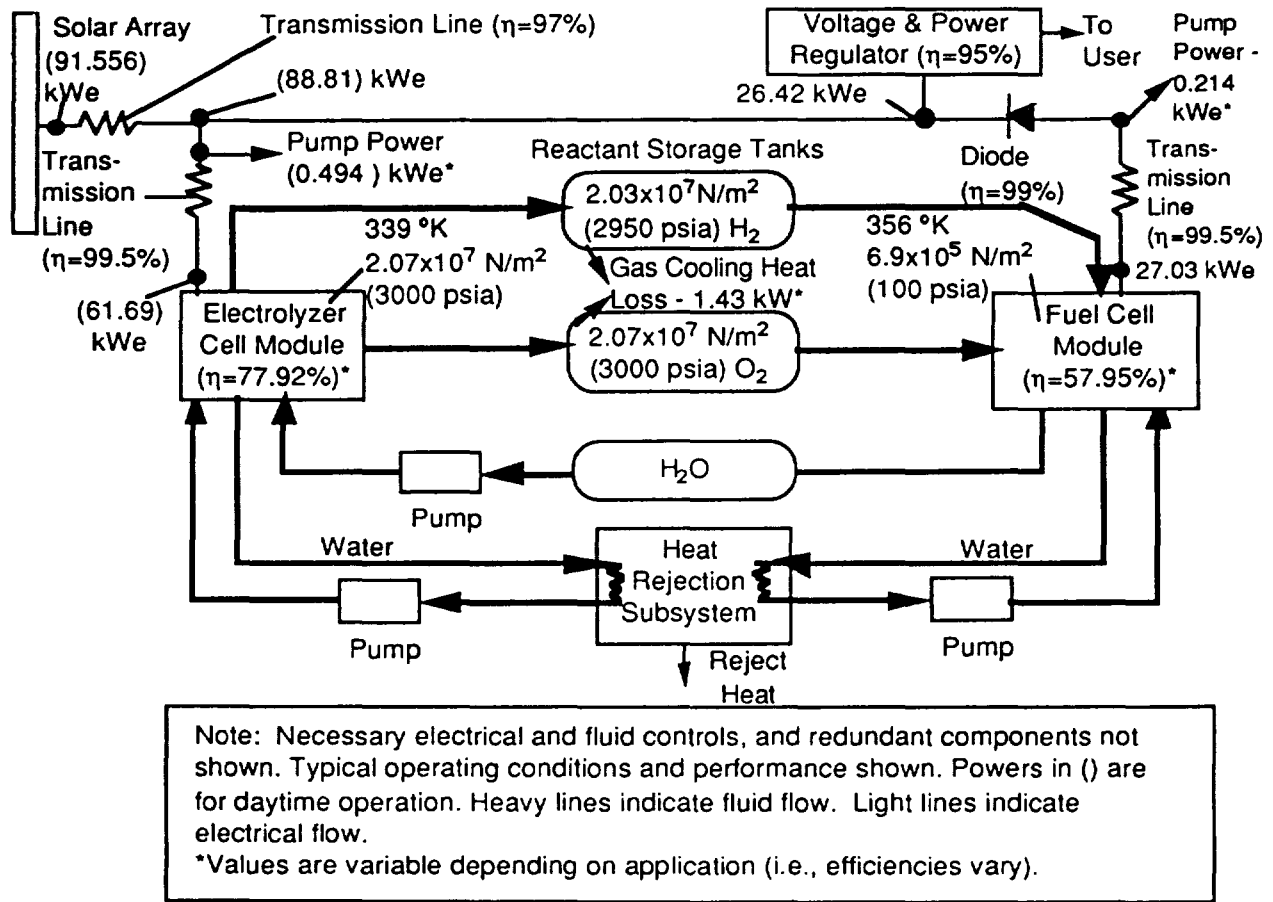

Figure D-1. 25 kWe PV/RFC power system schematic.

The RFC subsystem includes fuel cells, electrolysis cells, water thermal control (humidifiers, dehumidifiers, fluid controls), storage tanks (hydrogen, oxygen, water), thermal control (radiator, thermal control loops), and support structure.

Power conditioning is included to process power for running the electrolysis unit and to process the fuel cell output power. A shunt regular dissipates excess power from the array.

The current power system life goal is 15 years for SEI missions. A minimum life requirement of 10 years was assumed for the PVA subsystem. This appears to be a reasonable

goal based on the demonstrated cell performance and low degradation rate. A 20,000 hr life (at 50% duty cycle) was assumed for the RFC subsystem. The RFC life requirement appears to be a realistic, though challenging, goal based on previously demonstrated cell performance and allowing for partial redundancy in the design of critical components (i.e., valves, pumps). Preliminary studies have also shown that 3 RFC units (exclusive of the radiator and tanks), each rated at 50% of the total power, can provide enough redundancy to meet a 5 year life with a 50% duty cycle (Ref. D-1).

Photovoltaic Array Subsystem Description

The baseline PV cell is one being developed by Boeing Defense and Space Group in Seattle (Refs D-2 through D-4). The multi-bandgap or tandem cell consists of a double-heterostructure GaAs or AlGaAs thin film top cell and a polycrystalline CdZnS/CuInSe₂ heterojunction thin film lower cell as seen in Figure D-2 (Ref. D-2). The leading technology for thin film photovoltaic cells is CuInSe₂ (CIS) (Ref. D-5). In the cascade structure shown, short wavelength (high energy) photons are absorbed in a high bandgap material on top of the solar cell. The high bandgap material is transparent to longer wavelength (low energy) photons which pass through and are absorbed by a second layer consisting of a photovoltaic material with low bandgap.

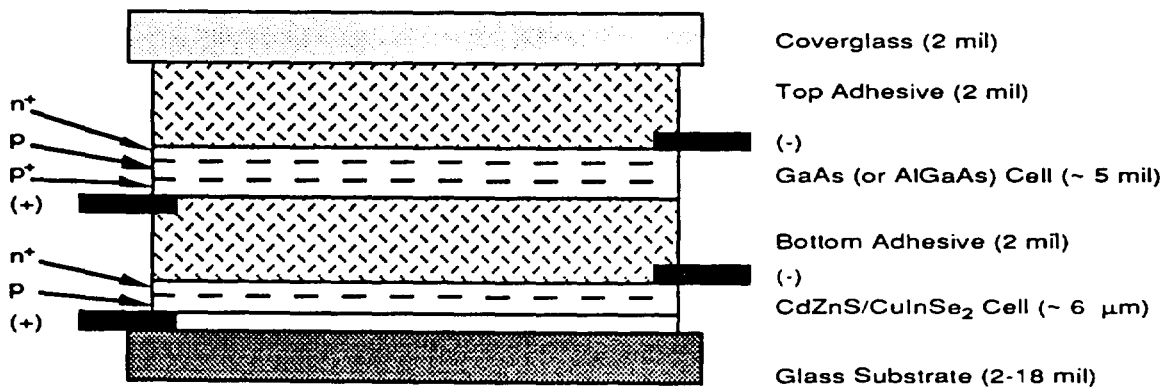

Vertical dimensions not to scale

Figure D-2. Tandem cell schematic.

Cascades can be configured as a monolithic cell in which the top cell is integrally deposited on the bottom cell (or vice versa), or mechanically stacked, in which the two sets of cells are formed separately. A mechanically stacked tandem configuration was chosen by Boeing in order to provide wiring flexibility and to minimize fabrication constraints. Since both cells are deposited as thin films, a very high specific power is possible.

The current Boeing design is based on a 2 cm x 4 cm cell area (Ref. D-2). The cell has an improved two-terminal configuration with voltage-matched monolithic subcell units. Voltage-matching is achieved by stacking one GaAs CLEFT (Cleavage of Lateral Epitaxial Film for Transfer) cell on top of four CuInSe_2 subcells monolithically interconnected in series to form a single cell unit.

An improved cell design could be achieved by using AlGaAs rather than GaAs as the top cell. The bandgap of CuInSe_2 is better matched to the bandgap of AlGaAs than GaAs. A 26% Beginning-of-Life (BOL) cell efficiency at AM0 is projected without structural change for this advanced cell.

The upper thin film cell is fabricated by the CLEFT technique using MOCVD for cell structure growth. The CIS cell fabrication includes sequential depositions of the Mo back electrode, CIS absorber layer, and CdZnS window layer. This is followed by photolithographic patterning and etching to form a solar cell device. Deposition of grid metal and addition of an anti-reflection coating complete the cell fabrication process.

The individual PV panels are either small enough to be transported to Mars as designed or are hinged for easy deployment. The panels lie horizontal and do not track the sun. Trade studies done by Rocketdyne showed that there was no advantage to tracking arrays since much of the cell input is from diffuse light.

Planar arrays can be subdivided into two broad categories: rigid and flexible (Ref. D-6). Rigid arrays are PV arrays that are mechanically stiffened with a honeycomb structure, usually made of aluminum, sandwiched between two facesheets that provide back side shielding for the PV cells and provide enhanced mechanical support to the structure. Rigid arrays are used in high

risk, unknown environments, where weight and cost are a secondary concern. Rigid arrays provide the most mechanical support and the most survivability. However, the rigid array is not suitable for planetary surface applications due to the mass penalty.

Flexible arrays are typically a Kapton substrate/superstrate which sandwich the PV cells and electrical circuitry, and are very attractive due to the significant mass savings over rigid panel arrays. Within the flexible arrays, there are three types: the roll-out type, the fold-out type, and the inflatable type. A flexible array is recommended for SEI surface power applications.

The Advanced Photovoltaic Solar Array (APSA) is an example of future flexible fold-out arrays (Ref. D-7). There are three elements to the APSA array: the flexible plastic and solar cell blanket (contributes about 50% of the mass), the deployment mast and mast housing (accounts for approximately 34% of the mass), and the blanket stowage compartment (16% of the mass) (Ref. D-6). The APSA wing consists of a flatfold, multiple panel, flexible blanket on which solar cell modules are installed and connected to printed circuit electrical harnesses that run along the outside longitudinal edges of the blanket assembly. Any type of solar cell can be utilized with the APSA approach. For launch, the accordion-folded blanket is stowed in a graphite/epoxy blanket during launch. The blanket is deployed (unfolded) by extending a motor-actuated, fiberglass, continuous longeron lattice mast that uncoils from an aluminum cylindrical canister structure. APSA is designed for zero g operation. Additional support structure would be required for planetary surface applications.

Inflatable arrays offer promise for missions which are driven by mass and/or the radiation environment. Inflatable arrays require the use of thin film PV solar cells. For a 100 W array (EOL) the mass breakdown is as follows: inflatable torus contributes 0.793 kg, the thin film solar array blanket 0.793 kg, and the support equipment 1.36 kg, resulting in a small satellite array specific power of about 34 W/kg (Ref. D-6).

An array deployment mechanism is required for automatic or robotic deployment. Array deployment alternatives include spring stored "one time deployment" and motor-driven

deployment systems. The deployment mechanism is critical from a reliability standpoint and may also contribute significantly to the system mass. The deployment mechanism for Mars systems must also maintain array rigidity during wind storms and must be designed to prevent resonating of the structural due to the natural frequency.

Some form of structure may be used to keep the arrays off the surface or to prevent the arrays from being disturbed by Martian winds. This system would have increased mass over one which is simply rolled out onto the planetary surface.

RFC Description

The RFC converts electrical energy into chemical energy and stores the energy for future use. An RFC is an energy storage device similar to a secondary battery. The RFC can be divided into six major subsystems for development purposes: (1) a fuel cell stack, which electrochemically converts hydrogen and oxygen into electricity; (2) an electrolyzer cell stack, which electrolyzes the fuel cell product water into gaseous hydrogen and oxygen reactants using externally provided power; (3) water management which removes moisture from the electrolysis cell product gases and humidifies fuel cell reactants to maintain proper cell membrane moisture content; (4) thermal management, which removes waste heat from the system, maintains the proper membrane temperature, and prevents boiling or freezing in critical flow paths; and (5) reactant storage (hydrogen, oxygen, and water).

An RFC operates as a fuel cell during its discharge energy production phase and as an electrolyzer during its charge phase. An external power source must be used to provide power to the electrolyzer. The electrolyzer can produce high pressure oxygen and hydrogen gas for a gaseous reactant storage of relatively low volume.

Two types of fuel and electrolysis cell technologies are available: alkaline and Proton Exchanger Membrane (PEM). PEM fuel cells and electrolysis cells were selected for this study since these technologies were shown to be the preferred RFC approach in a recent LANL study done for NASA (Ref. D-8). PEM cells were recommended since they are the only technology

which can meet the efficiency, life, cycle life, and turndown required for lunar and Mars applications. In addition, PEM electrolysis cells are superior to alkaline cells in ruggedness and reliability. The basic design and operation of the PEM RFC system are described in the following paragraphs.

Fuel Cell Description. Fuel cells operate by separation of two electrocatalytic conversion reactions with an ionic conductor, as seen in Figure D-3 (Ref. D-1). Charge moves through electron conductors connecting the two electrocatalytic zones, where electron transfer results in chemical reactions. Ionic transport through the separator completes the process.

The PEM fuel cell incorporates an ion exchange membrane, typically a polyperfluorosulfonic (PFSA) acid sheet, as the ionic conductor. This component sustains transport of hydrated hydrogen ions, protons (H^+), associated with water. Protons are generated at the porous anode electrocatalytic layer and transport through the ionic conductor to the cathode electrocatalytic layer. At the cathode, protons react with oxygen to form water. Product water exhausts from the cathode compartment.

Hydrogen and oxygen gases are stored at 2.07×10^7 N/m² (3,000 psia) (Ref. D-9) for use in the fuel cell. The gases are regulated down to fuel cell operating conditions (4.14×10^5 to 6.9×10^5 N/m² or 60 to 100 psia). Oxygen is regulated to a few psi higher than hydrogen (for safety reasons) to insure that only oxygen is entrained in the product water. The reactant gases must be humidified prior to reacting in the stack. Humidification will be discussed in the water management section.

The hydrogen and oxygen gases are combined in the fuel cell to generate electricity and water. The product water is discharged into the cooling water loop. As the cooling water accumulator approaches the filled condition, the product water drain valve opens to allow water to flow to the storage subsystem.

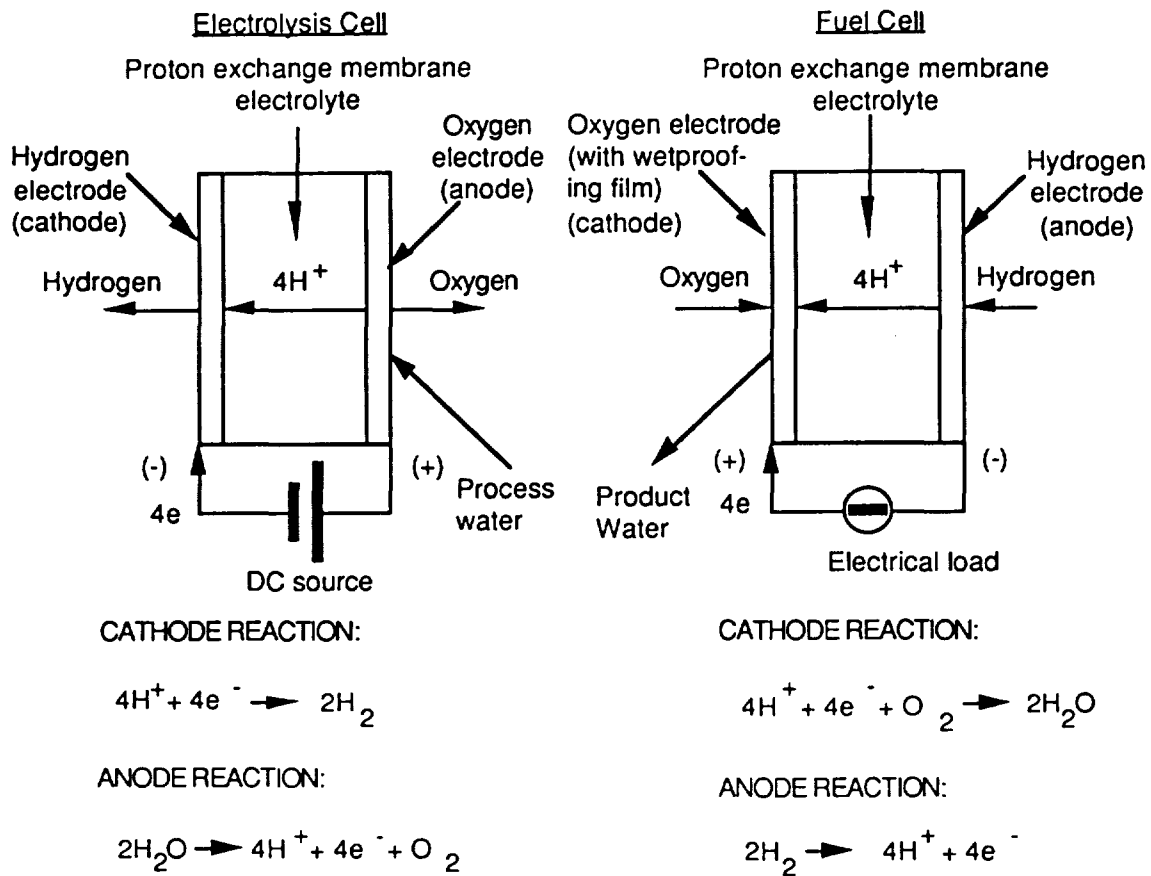

Figure D-3. Acid PEM electrochemical cell reactions.

The product water which leaves the fuel cell stack will be saturated with oxygen. This oxygen must be removed prior to entering the water storage tank. An approach for doing this has been demonstrated (external to the fuel cell) by Hamilton Standard, as seen in Figure D-4 (Ref. D-9). Water passes through an ion exchange membrane from the product water stream to humidify the dry hydrogen gas. Hydrogen diffuses from the hydrogen stream through the membrane to the water stream and combine with the oxygen to form water. Excess hydrogen is returned to the hydrogen stream using an electrochemical hydrogen pump. Thus, only gas free water returns to the storage tank.

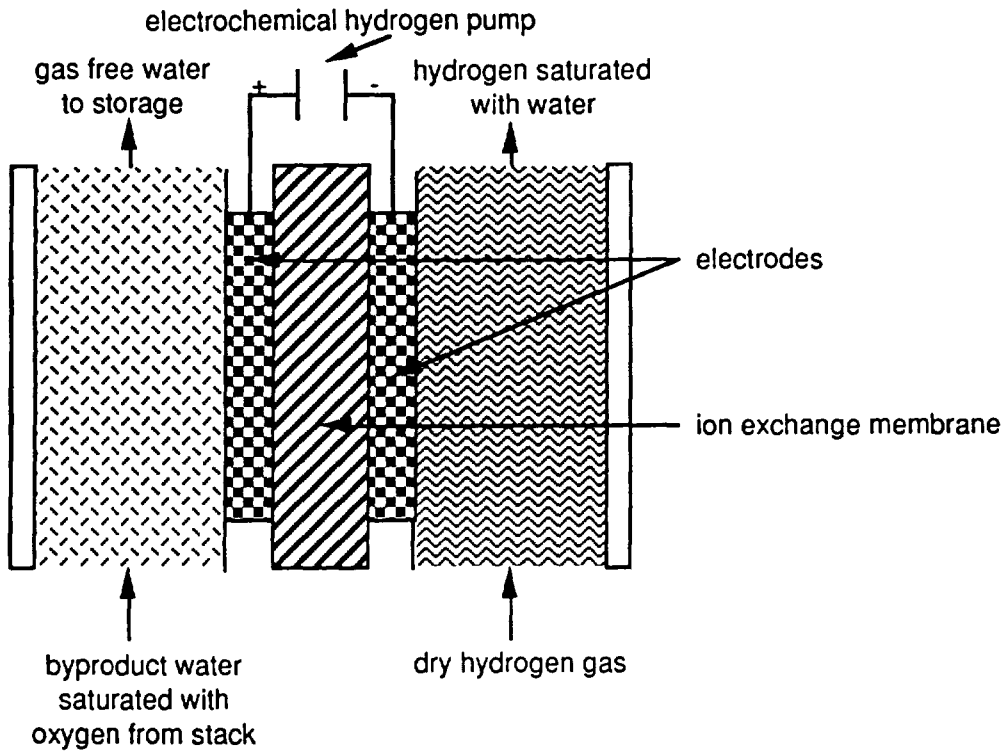

Figure D-4. Fuel cell product water deoxygenator.

The fuel cell design options have to do with the type of membrane. Table D-1 (Ref. D-9) compares the fuel cell design options on a power density basis. The values in this table assume a system with 25 kWe net output continuously, 55% fuel cell thermal efficiency (based on 1.48 VDC) for 20,000 hours, and a design that is thermal vacuum compatible.

TABLE D-1. FUEL CELL DESIGN OPTION POWER DENSITY COMPARISON

Fuel Cell Subsystem Description	Nafion 120 Membrane (current)	Nafion 125/117 Membrane (advanced)	Dow Membrane (advanced)
	W/kg	W/kg	W/kg
"SOA Design" with Porous Hydrophillic Phase Separators (Space Station design)	103	184	307

Electrolyzer Cell Stack Description. The acid PEM electrolyzer has the same type of ion exchange membrane as the PEM fuel cell to transfer H⁺ protons from the anode to cathode as was shown on the left of Figure D-3. Liquid water is pumped from the water storage tank by the water feed pump to the electrolyzer, as was seen in Figure D-1. The water feeds into the cell stack on the anode side of each cell. Some water passes across the proton exchange membrane (PEM) forming a second water loop. Excess anode water loop flow is used to remove waste heat from the stack. Separators in the cell stack separate the hydrogen and oxygen gases from the liquid water streams, as seen in Figure D-5 (Ref. D-9). The separated gases (saturated with water vapor) are fed into regenerative dryers or are fed directly to the reactant storage tanks.

Various electrolyzer options were identified involving different cell spacings and different membranes. The estimated power densities for each design is shown in Table D-2 (Ref. D-9). Table D-2 values assume a system with 70% electrolyzer thermal efficiency for 20,000 hours, 2.07×10^7 N/m² (3,000 psia) gas generation pressure, thermal vacuum compatible design, and 13 kg per hour of water electrolyzed. Only the Nafion 120 membrane has been life tested at 2.07×10^7 N/m² (3,000 psia).

TABLE D-2. ELECTROLYZER DESIGN OPTION POWER DENSITY COMPARISON

Electrolyzer Subsystem Description	Nafion 120 Membrane (current)	Nafion 125/117 Membrane (advanced)	Dow Membrane (advanced)
	W/kg	W/kg	W/kg
"SOA Design" with Static Separators	258	327	377
"Advanced Design" with Static Separators	347	392	414

The state-of-the-art (SOA) electrolyzer design utilizes the cell design which is used for U.S. and Royal Navy submarines. This cell design allows for 2.75 cells per cm (0.32 cm thick). The U.S. Navy utilizes a 2.07×10^7 N/m² (3,000 psia) stack while the Royal Navy uses a 1.03×10^6 N/m² (150 psi) stack design.

a) HYDROPHOBIC OXYGEN PHASE SEPARATOR

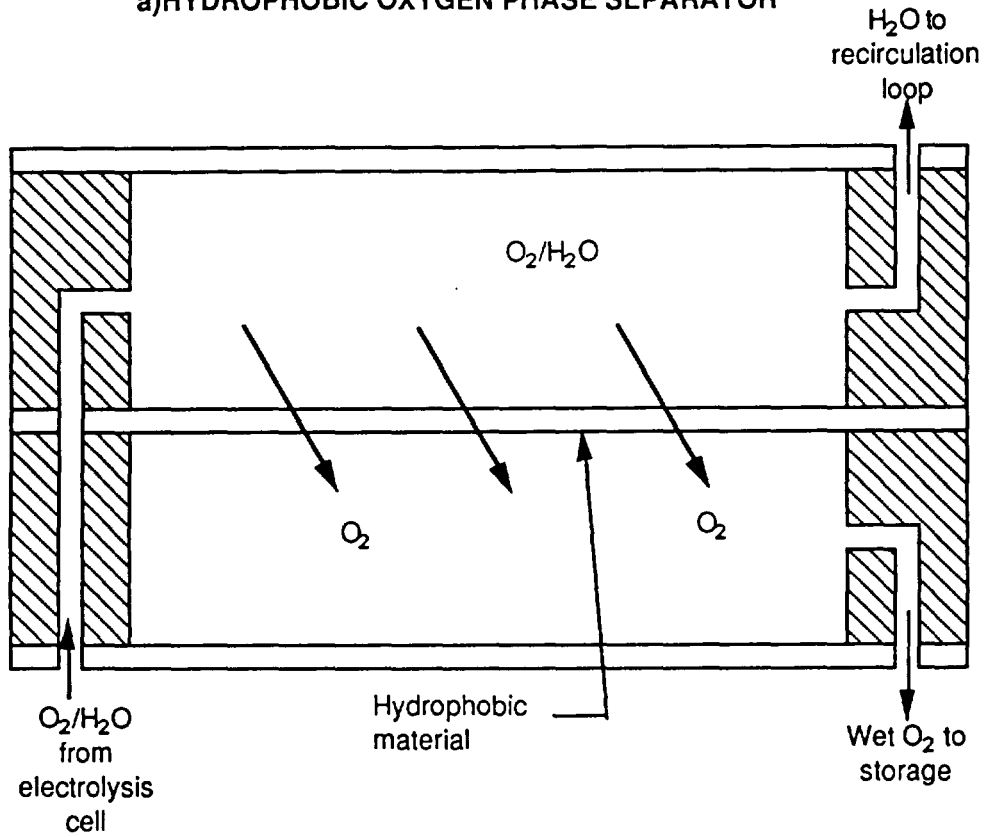

b) HYDROPHILIC/ELECTROCHEMICAL HYDROGEN PHASE SEPARATOR

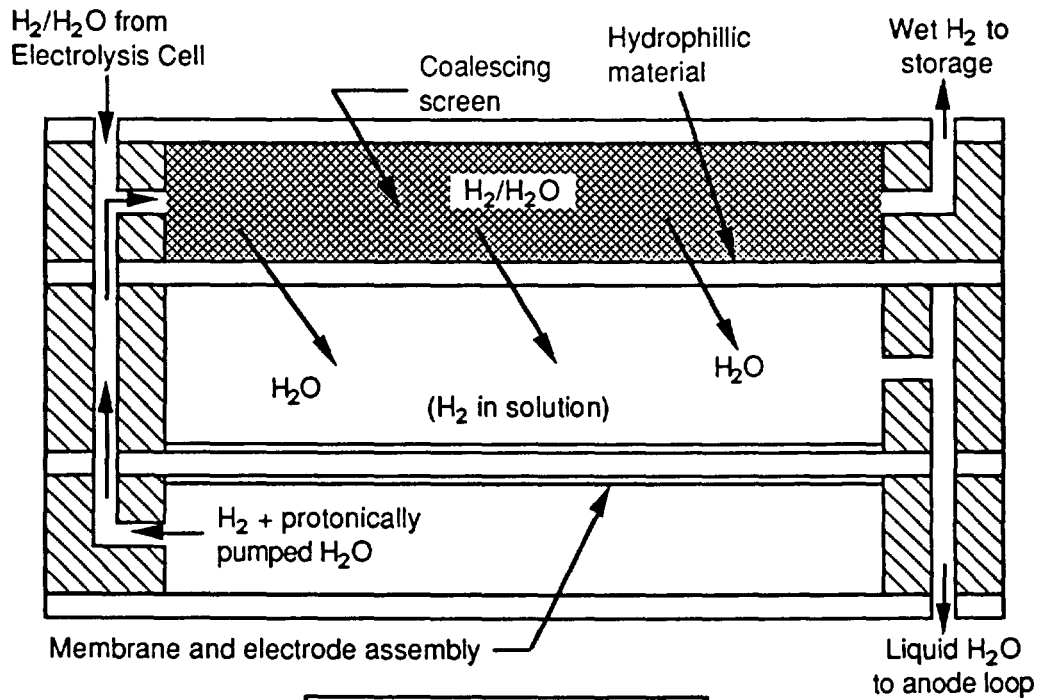

Note: Dimensions not to scale.

Figure D-5. Oxygen and hydrogen phase separators in electrolyzer stack.

The "advanced" (Ref. D-9) electrolyzer design utilized a cell design of 12 cells per cm (0.083 cm thick). This cell was incorporated into a 120 cell stack for testing by the U.S. Navy as a low mass oxygen generator prototype. The advanced cell stack was designed for a maximum pressure of 2.76×10^6 N/m² (400 psi) without a housing. SOA cell stacks use a cell size of about 214 cm² (16.5 cm circular cell). This appears to be the optimum efficiency cell size for several 2.07×10^7 N/m² (3,000 psia) electrolyzer applications (Ref. D-10).

RFC Thermal Management Subsystem Description. The thermal management subsystem provides temperature control, heat transport, and heat rejection functions. Pumped water and coolant loops provide the heat transport function, as seen in Figure D-6. A radiator is required to remove waste heat from the RFC system. There are inefficiencies in both the fuel cell stack and electrolysis cell stack which create waste heat. Membrane temperature must be controlled to prevent failures and meet life requirements. Water cools the stacks by collecting the waste heat and then transports the heat to one or more heat exchangers (one for electrolyzer and one for the fuel cell, or possibly a combined heat exchanger). These heat exchangers then transfer heat to the radiator coolant loop. Waste heat from the fuel cell may also be utilized to keep the electrolyzer from getting too cold.

The heat rejection assembly provides a means for rejection of waste heat to the environment. Radiators for heat rejection are in some cases a major component of the power system mass. Radiators can also be quite large due to the low operating temperature.

Various options are available for the radiator design. Pumped loop radiators have been used successfully for the space shuttle and will be used for Space Station Freedom (SSF). This type of radiator is best applied to missions with limited duration or to systems which are serviceable. Pumped loop radiators are less massive than state-of-the-art heat pipe radiator designs. Heat pipes offer the advantage of improved reliability and a graceful failure mode. A recent Rocketdyne study has shown that advanced carbon-carbon (C-C) heat pipe radiators can

be designed which are competitive in mass to pumped loop radiators. Thus, a heat pipe radiator was tentatively selected as the baseline design.

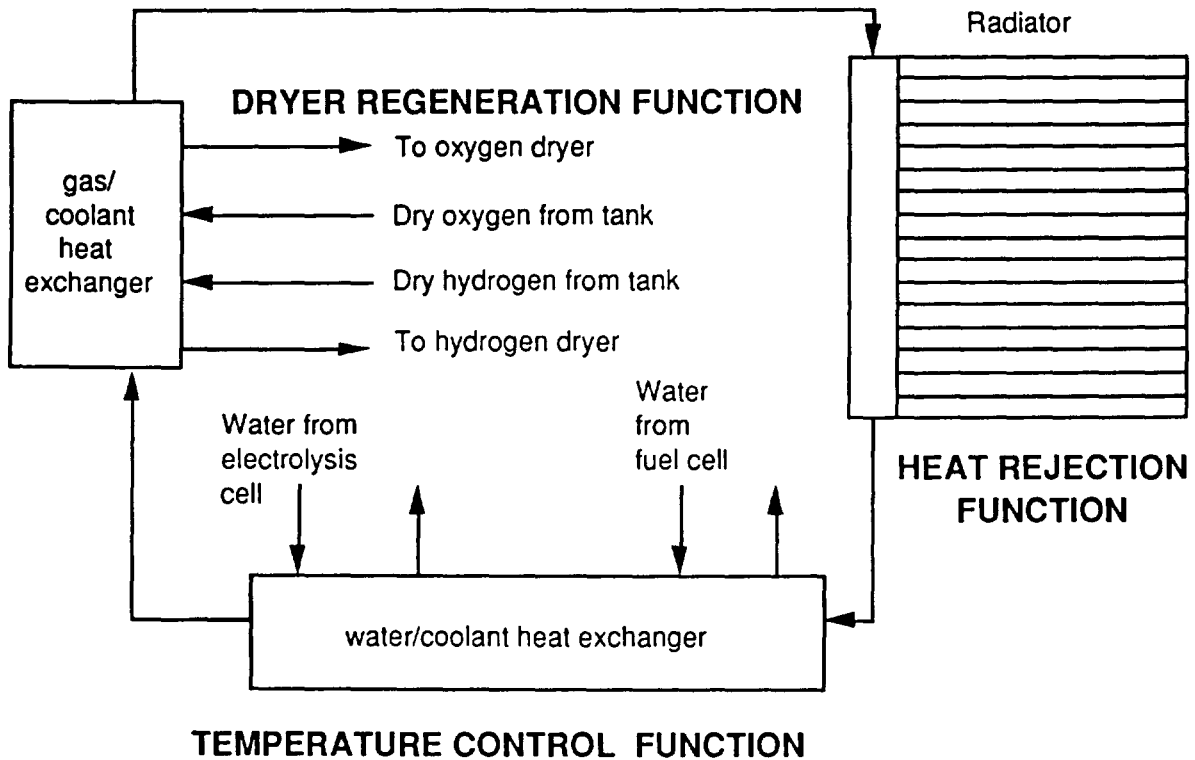

Figure D-6. Thermal management subsystem.

The baseline heat rejection assemblies for RFCs utilize lightweight, passive, reliable, heat pipe radiators that are sufficiently versatile to allow integration into a variety of configurations. The individual heat pipes operate independent from one another and thus the failure of a heat pipe will not result in failure of the complete radiator. The rectangular radiator heat pipe panel is attached to the coolant manifold. The cooling loop transfers heat to the heat pipes in the manifold heat exchanger. The heat pipe working fluid evaporates and travels to the top end of the heat pipes. The evaporated fluid is then condensed in the cooler section of the heat pipe. Both gravity and a small wick or grooves allow the liquid to return to the evaporator. A wick or groove is not absolutely necessary for vertically oriented radiators

(due to gravity return) but is recommended to insure good control of the fluid transport. The heat pipes may be either carbon-carbon tubes with metal liners (Monel for water or aluminum for ammonia working fluids) or metal heat pipes.

Condensation and freezing of the water in critical locations must be prevented by maintaining fluid temperatures within limits. Thermal control of the lines and tanks may be accomplished by insulation, trace heating, insulation and trace heating, or convective heating/cooling using the radiator coolant. Composite tanks need to be kept above -65 °F to prevent tank failure. The composite tank liner will begin to separate from the overwrap at this temperature and buckling will occur. It may also be desirable to prevent the water vapor in the gases from freezing in the tanks. Fluid lines may also require thermal control to prevent water freezing and clogging of lines (especially in the pressure regulators).

RFC Water Management Subsystem Description. Water management includes moisture control of the fuel cell membrane and the removal of moisture from electrolysis module product gases.

The moisture content of the fuel cell stack membranes must be carefully controlled to prevent dehydration and reduced life. The reactant gases must be humidified to maintain the proper membrane moisture content.

The traditional humidification approach for PEM fuel cells is shown in Figure D-7 (Ref. D-10). The humidifier automatically presaturates the incoming hydrogen and oxygen reactants to a dew point equal to the cell operating temperature. This latter approach was used in the Hamilton Standard SPE fuel cell. The problem with this approach is that the product water going to the storage tank is saturated with oxygen. If the oxygen is not removed from the water, then the gas will accumulate in the water tank and have to be vented off (undesirable loss of reactant).

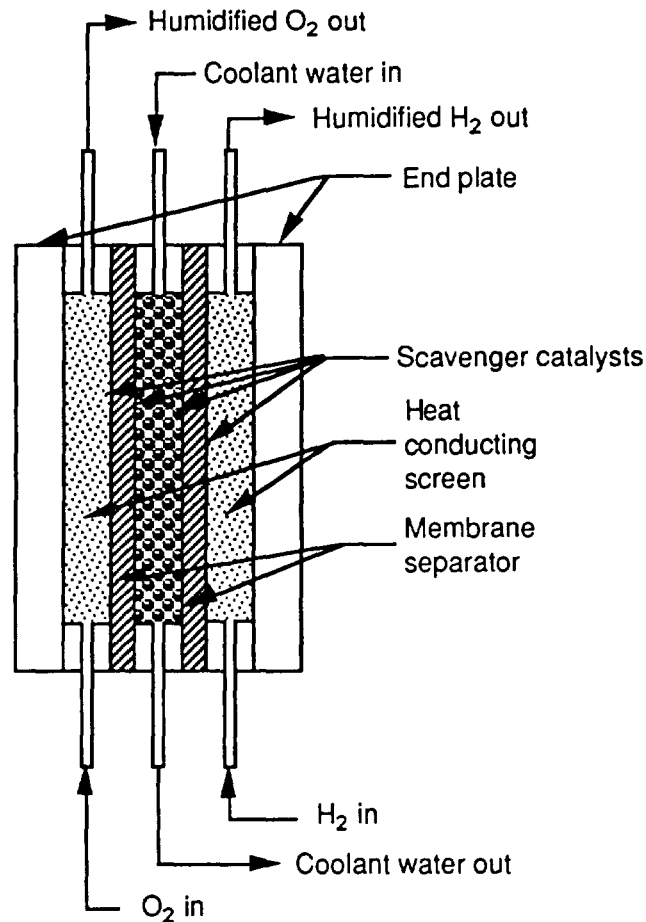

Figure D-7. SPE fuel cell reactant prehumidification approach.

Another gas humidification approach, which is more appropriate for space systems, was shown in Figure D-4 (Ref. D-9). This approach also removes the oxygen gas from the product water and there is no gas buildup in the tank. This concept converts the oxygen to water by diffusion of hydrogen across the membrane. A hydrogen electrochemical pump keeps hydrogen from evolving in the water. Excess hydrogen is pumped back to the hydrogen side of the device.

If regenerative gas dryers are used in the system, then the gas from the tanks will be partially rehumidified during regeneration of the dryers as is seen in Figure D-8 (Ref. D-11; only the oxygen humidification is shown). Heat must be added to the cool dry gases in order to vaporize the water in the dryers. The purpose of this process is primarily to recover water

from the gas dryers. Most of the gas humidification will be done using a humidifier such as was shown in Figure D-4.

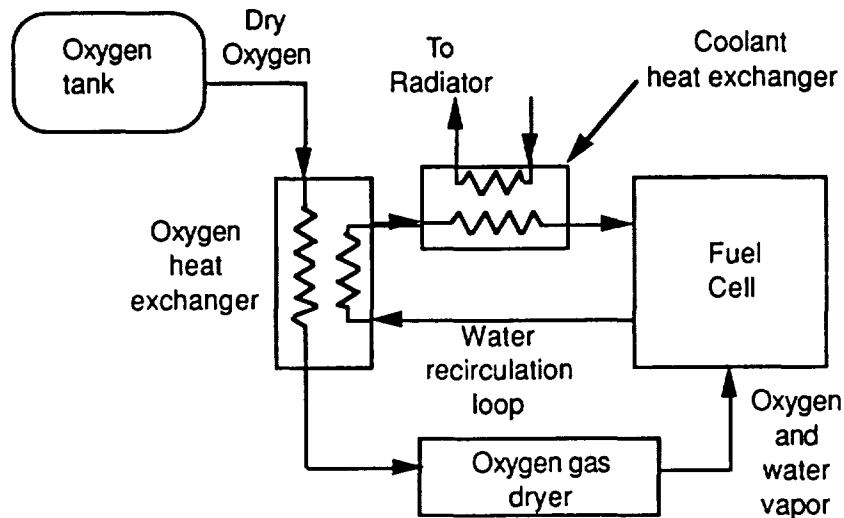

Figure D-8. Water recovery from the oxygen regenerative dryer.

Several approaches have been suggested for recovering moisture from the electrolyzer gases. The key concerns are preventing freezing of water in the lines and the mass loss from the system if the water is not fully recovered each operating cycle. The LANL study (Ref. D-8) proposes letting the water condense and freeze in the tank while keeping the feed lines heated. Some of the water is removed from the tank as a liquid by using a trap. The remainder of the water in the tank freezes. The residual water is recovered by heat input to the tank during the day as additional warm gas from the electrolyzer is introduced.

Another water recovery approach suggested by Hamilton Standard (Ref. D-11) is to dry the gases with regenerative desiccant dryers leaving only a trace of moisture in the gases. This would significantly lower the dew point for the remaining gases to a temperature which is below ambient or would not require much insulation or heat input to prevent condensation. A sacrificial dryer might also remove the remaining trace water. Moisture would be removed from the dryers during fuel cell operation by passing the dry gas from the tanks back through

the dryers at the lower fuel cell pressure (need large driving force to recover the water). Potential desiccants include silica gel and molecular sieve (Ref. D-12). Silica gel is used at lower temperatures (below 363 °K) due to its high moisture recycling capacity compared with other industrial desiccants (about 0.35 kg water/kg gel at 303 °K and 80% humidity per Ref. D-13). Molecular sieve is used at higher temperatures (>393 °K) due to its high moisture recycling capacity and physical stability at higher temperatures. Potential configurations for desiccant dehumidifiers include a packed bed, Teflon fiber plates, a corrugated structure, and coated parallel-passages. A coated parallel-passage concept appears to have a great potential to provide an effective dehumidifier. This design consists of parallel-walled passages (laminar flow channels) with fine silica gel particles (80-250 μm) glued to the walls.

RFC Storage Tank Description. For this study, it was assumed that oxygen and hydrogen would be stored at high pressure. The storage tanks will be made of composite materials. A metal liner is overwrapped with carbon or graphite fibers. The liner will probably be aluminum for the hydrogen tank and a corrosion resistant material such as Inconel, niobium, or tantalum for the oxygen and water tanks.

Reliability and life are the key areas of interest for tank design. Thus, materials must be selected which are stable against corrosion and hydrogen embrittlement for the system life. Current composite tank designs may exhibit high stress when driven through large temperature variations, so the liner materials must be carefully matched to the wrap material in terms of the coefficient of thermal expansion. Otherwise, tanks must be thermally controlled to limit temperature changes (may be difficult when going from non-operating to operating status). Tank linings must exhibit very limited corrosion even with pressurized oxygen storage and perhaps even with wet gas storage. Tanks must be rugged enough to survive the transportation phase of deployment. The use of multiple tanks may be required to meet system reliability

requirements. Some elementary cladding may be required to provide an element of shielding from meteorites (the system housing may also be used for this purpose).

PP&C Subsystem Description

The PP&C subsystem has not as yet been defined for this concept. Two basic approaches can be taken. In the first approach, which is the same as for the DIPS, the system is designed to provide a constant power and voltage output. This approach requires a dc voltage regulator to process the fuel cell output. In the other approach, the power conditioning is done at the user loads. In this second approach, the fuel cell output can vary with time (i.e., voltage is unregulated). This approach allows the power processing to be optimized for each load. The power input to the electrolyzer module can also be regulated within the RFC power system or as part of the recharging power system.

TECHNOLOGY ISSUES

Key issues for the PV subsystem are summarized in Table D-3. The key issues for development of a PEM RFC and their impacts are summarized in Table D-4.

TABLE D-3. PV SUBSYSTEM ISSUES, IMPACTS, AND DEVELOPMENT AREAS

Issues	Impacts	Potential Development Areas
Large array area due to low Martian insolation	<ul style="list-style-type: none"> •Increased life cycle cost (LCC) •Increased deployment time •Increased number of cells with reduced system efficiency and reliability 	<ul style="list-style-type: none"> •Higher efficiency top cell •Robotic or automatic deployment system •Thin film arrays •Roll-out arrays
Small cell size	<ul style="list-style-type: none"> •Increased number of cells with reduced system efficiency and reliability 	<ul style="list-style-type: none"> •Higher efficiency top cell •Larger size cells
Cell efficiency	<ul style="list-style-type: none"> •Increased array size and LCC 	<ul style="list-style-type: none"> •Higher efficiency top cell (AlGaAs)
Cell cost	<ul style="list-style-type: none"> •Increased LCC 	<ul style="list-style-type: none"> •Low cost production techniques
Deployment system and support structure weight	<ul style="list-style-type: none"> •Increased LCC 	<ul style="list-style-type: none"> •Flexible roll-out array •Robotic deployment
Operating temperature fluctuation and extremes	<ul style="list-style-type: none"> •Reduced cell life due to thermal stress/increased LCC 	<ul style="list-style-type: none"> •Design and test for appropriate environment •Test for thermal extremes
Martian wind	<ul style="list-style-type: none"> •Increased structure mass and LCC 	<ul style="list-style-type: none"> •Lightweight structure and tie-downs
Dust accumulation	<ul style="list-style-type: none"> •Increased array area and LCC •Maintenance cost 	<ul style="list-style-type: none"> •Robotic dust removal system

TABLE D-4. PEM RFC DEVELOPMENT ISSUES

Issues	Impacts	Potential Development Areas
Limited life components and system reliability	<ul style="list-style-type: none"> • Increased frequency of replacement, maintenance • Mass and complexity of redundant components 	<ul style="list-style-type: none"> • Development of passive system • Long life pumps, drives, valves, and controls
Material compatibility	<ul style="list-style-type: none"> • Reliability/life 	<ul style="list-style-type: none"> • Materials for use with high pressure O₂ • Materials for wet gases • Materials immune to H₂ embrittlement
Cell temperature and moisture control of fuel cell membrane	<ul style="list-style-type: none"> • Life 	<ul style="list-style-type: none"> • Thermal control loops • Passive internal fuel cell gas humidifiers • Regenerative gas dryers
Oxygen in fuel cell water	<ul style="list-style-type: none"> • Mass/energy loss from the system due to venting of oxygen from water tank 	<ul style="list-style-type: none"> • Internal deoxygenator in fuel cell
Water in electrolyzer gases	<ul style="list-style-type: none"> • Tank corrosion if wet gas stored (life and reliability) • Tank insulation mass • Complexity of gas dryer systems • Clogging of lines due to ice • Energy and mass loss 	<ul style="list-style-type: none"> • Low mass desiccating regenerative dryers • Tank liner materials • Tank and/or line thermal control
Large, massive radiator due to low heat rejection temperature	<ul style="list-style-type: none"> • Increased transportation cost, complicated vehicle design 	<ul style="list-style-type: none"> • Higher temperature cells (higher reject temperature) • Low mass carbon-carbon radiator • Heat pump
Reactant storage system mass and volume	<ul style="list-style-type: none"> • Transportation cost 	<ul style="list-style-type: none"> • Cryogenic or supercritical storage
Efficiency of electrolysis cell reduced at higher pressure	<ul style="list-style-type: none"> • Transportation cost • Increased waste heat; larger radiator 	<ul style="list-style-type: none"> • Low mass tanks, PV arrays, and radiators • Tank pressure following
High Water Purity Requirement	<ul style="list-style-type: none"> • Performance • Life 	<ul style="list-style-type: none"> • Use materials that won't contaminate water • Deionizer

TECHNOLOGY ASSESSMENT

The technology bases were assessed for the following major PV/RFC subsystems:

- PV array;
- fuel cell stack;
- electrolysis cell stack;
- RFC thermal control subsystem;
- RFC water control subsystem;
- RFC reactant storage subsystem; and
- PP&C.

The technology readiness of each assembly was evaluated using the NASA technology readiness levels. These evaluations are summarized in Table D-5 which shows that the RFC has technology readiness levels ranging from 3 to 5, depending on the particular subsystem. The technology base for the PV and RFC subsystems is discussed in the following sections.

TABLE D-5. PV/RFC TECHNOLOGY ASSESSMENT

Subsystem	Technology Readiness Level	Comments
GaAs/CIS PV cells	5	Pilot development phase for cells; APSA program
Fuel cell stack	3.5	Early design flown on Gemini; prototype developed for space station RFC based on earlier Hamilton Standard design; new International Fuel Cell design not flown (engineering qualified in 2.5 years)
Electrolysis cell stack	4	Large database for naval applications; prototype developed for space station applications
RFC thermal management	3	Radiator component development currently underway; long life active thermal control components not developed for space applications; some sealed water pumps and drives for terrestrial applications have demonstrated long life
RFC water management	3	Silica gel dryers widely used for gas drying in terrestrial applications; limited experience with regenerative systems
RFC reactant storage tanks	5	Small tanks successfully flown; need corrosion resistant liner development
PP&C	5	Similar components under development for Space Shuttle Freedom

PV Array State-of-the-Art

The current cell technology level is between 5 and 6 on the NASA scale. The Boeing cell development is in the pilot line phase now (Ref. D-14). Production volume is expected by 1996. The GaAs top cell is currently made by Kopin company while the bottom CIS cell is made by Boeing. An advanced cell design (AlGaAs/CIS) could be available before 2008. Cell testing has progressed through the preliminary qualification stage. Testing has included thermal cycling, UV illumination, off-angle, vacuum stability, and humidity tests. Small coupon panels have been tested for mechanical shock, pyro shock, acoustics, vibration, and thermal cycling. Current cell size is 2 x 4 cm (1991). Boeing is also working on a thin plastic substrate to replace the current glass substrate.

Array development has been done for both rigid and flexible arrays. Various array technologies are summarized in Table D-6 (Ref. D-6). The roll-out type array approach was developed in the early 70's at Wright-Patterson Air Force Base during the Flexible Roll-Up Solar Array (FRUSA) program. The same basic technology is used today for power generation on the Hubble Telescope. Some of the arrays in the flexible fold-out category are the SAFE array, Mil-Star, Space Station and the APSA array developed by TRW for JPL. The APSA array is designed for GEO orbit. The APSA program has been ongoing for several years and has significantly reduced the mass of arrays using a flexible array design. APSA has a goal of demonstrating a producible array system having a specific power greater than 130 W/kg (BOL) at 10 kW (BOL). A research and development array that should be seen as both "fold" and "roll" out is the inflatable array. The inflatable array approach is funded by DARPA and is being developed and build by L'Garde Inc . The DARPA program is called Inflatable Torus Solar Array Technology (ITSAT) and is scheduled to conduct a space flight experiment in the 4th quarter of 1993. The inflatable array is considered a high risk - high payoff approach.

TABLE D-6. DESCRIPTION OF VARIOUS ARRAY TECHNOLOGIES AND APPROXIMATE PERFORMANCE FIGURES OF MERIT (IN EARTH ORBIT)

Name	Description	PV CELLS (BOL)	Base Power (EOL kWe)	Life (years)	Area Density (W/m ²)	Specific Power (W/kg)
Rigid Honeycomb (Typical)	Aluminum honeycomb	Si: BSF 8 mil	3.4	7	128.3	32
HUBBLE	Roll-out flexible blanket	Si: 2x4 cm ² BSFR	4.4	2	117	19
Space Station	Flexible Kapton fold-out blanket	Si: wrap through contacts 8x8 cm ²	75	4	90	66
APSA	Flexible Kapton fold-out blanket	Si: 2x4 cm ² BSF 13.8%	3.7	10	95	93
SUPER (Planar)	Flexible fold-out with Beryllium	GaAs/Ge 6x6 cm ² 18%	5.3	5	121.7	26.5
AHA	Ti honeycomb with 1.4 x concentrating shutters	GaAs/Ge 2 junction 24%	5	10	95.5	28.8
ESSA	Al honeycomb with protective shields	GaAs/Ge single junction 18%	5	10	137	23.2

The current application cell design could utilize either an inflatable array, an APSA type array (with additional support structure), or roll-out array.

RFC State-of-the-Art

Hamilton Standard designed, developed, tested, and delivered a 1.5 kW PEM breadboard RFC system to Johnson Space Center (JSC) in January 1983 (Ref. D-11). The RFC breadboard system was tested for 2,000 ninety minute orbital cycles (1,630 at JSC). The fuel cell module of the RFC was later replaced by an advanced module and tested for about 500 hours. This breadboard was not tested in a relevant environment (i.e., vacuum or low pressure carbon dioxide, low gravity, day/night thermal cycles, etc.). In addition, the breadboard did not include

PHOTOVOLTAIC/REGENERATIVE FUEL CELL POWER SYSTEM TECHNOLOGY ROADMAP

✓ key components such as composite tanks, radiators, and long life active thermal control components.

Although the fuel cell technology is fairly well developed in acid systems, the system integration of the accessory components and cell stack is not as mature as that of the alkaline fuel cells. The technology readiness of the PEM RFC power system is estimated to be 3.5 for the current application.

Fuel Cell State-of-the-Art

A PEM fuel cell developed by Hamilton Standard (United Technologies) was used on the Gemini missions from 1962-66 (Ref. D-15). After the Gemini space flights, Hamilton Standard pursued further development of PEM fuel cell technology. The major breakthrough was the replacement of polystyrene sulfonic acid ion exchange membrane by perfluorinated sulfonic acid polymer, Nafion, produced by DuPont, as the electrolyte. PEM fuel cell technology has since advanced with the introduction of the Dow experimental membrane. The Dow membrane has greatly increased the current density of PEM systems over the current densities available from DuPont's former state-of-the-art membrane, Nafion 117. Dow has not yet started production of their membrane, but is supplying it to fuel cell manufacturers for testing and evaluation.

Cell lives of 60,000 hours (6.85 years) in the laboratory have been achieved by Hamilton Standard with PEM fuel cells (Refs. 10 and 11) because there are no corrosive electrolytes to cause contamination. PEM fuel cells can operate with high concentrations of gases like CO₂, whereas the KOH electrolyte of alkaline fuel cells would react with the CO₂ and cause precipitation.

A PEM fuel cell subsystem was developed by Hamilton Standard in the 1980s for a RFC demonstrator for the Space Station Freedom (Ref. D-1). The fuel cell had a 1 to 2 kWe rating. The RFC demonstrator underwent parametric testing at the factory prior to its delivery to NASA/JSC.

Treadwell Corporation has designed and built a PEM fuel cell stack and associated test stand (Ref. D-16). The stack was designed for an output power of 10 - 30 kW. Various stacks have been tested. This fuel cell system was designed for autonomous underwater vehicles.

Ballard Technologies Corporation in Canada has built small demonstrator stacks with the Dow membrane and was the first to achieve high power densities in a solid polymer electrolyte fuel cell (Ref. D-15). The Ballard design appears to be similar to the Hamilton Standard fuel cell design.

Siemens in Germany (under a license from Hamilton Standard) is also using the PEM technology to develop fuel cell systems for submarine power systems (Ref. D-15).

LANL has two of the Dow PEM fuel cells on test, achieving 0.92 V at 2,153 A/m² (Ref. D-15). Dow has made a commitment to provide membranes to a product specification; whereas, they were previously in process development and membrane quality/consistency were not up to par for commercial use.

Acid (PEM) fuel cells are well suited to passive water removal. The absence of a liquid electrolyte that has narrow concentration limits makes water management less of a problem. Ergenics Power Systems, Inc., is developing a flight-qualified 200 W fuel cell with passive water and heat removal for a Space Station extravehicular mobility unit (Ref. D-15).

International Fuel Cells (IFC) has tested a 16 cell, 5 kW stack using Nafion membranes and is now evaluating the Dow membranes. This is a new PEM design which is different from the fuel cell which flew on Gemini. IFC also worked on a "static" PEM fuel cell (Ref. D-17). This concept eliminated the power consuming pumps associated with the management of the product water. The design also incorporated heat pipes into the system to create a "static" waste heat management subsystem which eliminated the cooling subsystem parasitic power loss. This approach offered significantly improved reliability and higher system efficiency. IFC completed breadboard experiments and validated this system concept. IFC has since changed their design (Ref. D-17). The latest design has no heat pipes and requires a cooling loop with a pump. However, the water removal still utilizes a static approach. This concept is proprietary and

few details were available from IFC. However, this concept uses graphite plates and either Dow or Nafion 117 membranes (Nafion is the baseline). IFC has tested both single cells and short stacks with its latest design. IFC has a DARPA contract to produce a 7.5 kWe fuel cell for unmanned underwater applications. This power plant will be available (engineering qualified) in 2.5 years. The life of this fuel cell is expected to be a few thousand hours. The DARPA fuel cell technology should be suitable for space since it is not affected by a zero gravity environment.

Electrolysis Cell Stack State-of-the-Art

Hamilton Standard has an extensive data base in high-pressure electrolysis. The 2.07×10^7 N/m² (3,000 psi) cell design is currently used in the oxygen generation plant (OGP) developed for the U.S. Navy and in the production units for the British Navy nuclear submarines. Hamilton Standard has over 20 years experience building PEM electrolyzers for the Navy (Ref. D-15). They have demonstrated 13 years of continuous usage of a PEM electrolyzer cell in the laboratory. U.K. Navy electrolyzer cells have accumulated a total of 69,000 system hours of usage as of 1/92 without any failures. One Navy electrolyzer cell stack has accumulated over 13,000 hours of usage at sea over a 5 year period (Ref. D-11).

During the 1980s, three demonstrators were developed by Hamilton Standard (Ref. D-1). These electrolyzers were fabricated and then tested by NASA. Each of these systems made use of the identical 213 cm² SPE water electrolyzer design used for naval applications.

The first of these systems was a PEM RFC demonstrator for Space Station Freedom. Over 2,000 simulated orbital cycles were accumulated on this hardware. This program demonstrated a closed system fluid cycle balance, direct solar array/electrolyzer voltage/current control compatibility (no power conditioning required), and an energy storage efficiency of 48% with the electrolyzer at ambient temperature. Later in the program the PEM fuel cell was replaced by an alkaline fuel cell and the system was operated for 100 cycles with no problems. This test showed the compatibility between a PEM electrolyzer and an alkaline fuel cell (i.e., no KOH ions

went to the PEM electrolyzer through the product water and no sulfonic acid groups passed through the PEM electrolyzer gases to the fuel cell; some people had thought that the acid and base in each unit would mix and neutralize each other). Recently, some of the electrolyzer cells were replaced by high performance cells using the Dow membrane. The electrolyzer module underwent additional testing and showed significant performance improvement, especially at higher current densities.

The second Hamilton Standard demonstrator was an oxygen generator assembly developed under contract to Boeing Aerospace and Electronics Company (Ref. D-1). The operating pressure, temperature and current density of this demonstrator are within the experience of naval applications. However this demonstrator differed from the Navy data base because of the need to operate in a microgravity environment and use processed hygiene water as the feedstock. Two membrane static phase separators are used to replace the pressure vessel phase separators used previously. The demonstrator was activated at NASA/MSFC in November 1990 and operated for 529 hours which exceeded the test objective of 450 hours. This program successfully demonstrated the operation of microgravity phase separators. There are continuing tests of this unit to improve the cell voltage performance.

The third Hamilton Standard demonstrator system was developed to show the feasibility of producing 2.07×10^7 N/m² (3,000 psi) hydrogen and oxygen on orbit for periodic rocket motor firing to maintain Space Station Freedom orbital altitude (Ref. D-1). Under NASA sponsorship, initial work was performed to convert the heavy 2.07×10^7 N/m² (3,000 psi) naval SPE electrolyzer design into a space flight configuration (Ref. D-10). This required development of a lighter and smaller package. Changes were made to the supporting pressure vessel and fluid manifold. The use of two torispherical domes opposed on either side of a central fluid plate allowed for a wall thickness of as low as 0.64 cm when using Inconel or other high strength materials. The fluid plate manifold is pressure balanced between the two pneumatic domes which eliminates the need for a thick plate to resist the gas pressure load, as used in the Navy hardware. This work produced a prototype cell stack for space applications that weighs

less than 91 kg total (down from 454 kg for the 100-cell naval cell stack and pressure vessel). This unit was delivered in 1990. This demonstrator has been set up and operated intermittently at NASA/JSC during the last year. This cell was recently tested by JSC for 500 hours (Ref. D-1). This unit operates at 322 °K at a thermal efficiency greater than 70% (defined as the ratio of the power input minus the heat rejected to the power input).

RFC Thermal Management Subsystem State-of-the-Art

NASA LeRC is currently carrying out an integrated multi-element project for the development of space heat rejection subsystems with special emphasis on low mass radiators in support of SEI power system technology (Ref. D-19). This effort involves both in-house and contracted efforts. Contracted efforts involving Rockwell International (RI) and Space Power Incorporated (SPI) are aimed at the development of advanced radiator concepts (ARC). NASA LeRC is also involved in a joint program with DOE to demonstrate a flexible fabric heat pipe radiator concept being developed by Pacific Northwest Laboratories (PNL). In-house work at NASA LeRC is designed to guide and support the overall program by system integration studies, heat pipe testing and analytical code development, radiator surface morphology alteration for emissivity enhancement, and composite materials research focused on the development of low mass, high conductivity fins. This program is concentrating on technologies capable of development before the end of the decade for both surface power and nuclear electric propulsion (NEP) applications.

Specific objectives of the ARC contracts are to achieve specific mass values $<5 \text{ kg/m}^2$ with radiator surface emissivities of 0.85 or higher at typical radiator operating temperatures, and reliability values of at least 0.99 for the heat rejection subsystem over a ten year life. These figures represent a factor of two improvement over the currently considered heat rejection subsystem for SP-100, and even greater improvement factors for state-of-the-art heat rejection systems used in current spacecraft applications.

Presently, Rocketdyne division of Rockwell International is involved in the development of a carbon-carbon (C-C) or graphite heat pipe radiator panel. Rocketdyne has a NASA contract entitled "SP-100 Advanced Radiator Concepts" which started in 1987 and is part of the CSTI (Civilian Space Technology Initiative) program. This program will be completed in January of 1993. This program involves development of a C-C heat pipe suitable for use in an SP-100 radiator. However, this technology will be suitable for other radiator applications as well including RFC power systems (using other working fluids such as water and/or ammonia). The hope is that this program will develop generic technology which can be used for all future space radiators because of its reduced mass compared to metal heat pipe radiators. Carbon-carbon is a new structural material which requires different fabrication techniques than for metals or composites. A key objective of this program is to demonstrate the ability to fabricate C-C heat pipes with a thin metal liner, wicks, caps, and fill tube. The brazing technique required to attach liners is the same as would be required to attach manifolds to the heat pipes. Heat pipes filled with potassium will be designed, fabricated, and tested during this program. Thermal cycle testing will be done in a vacuum to demonstrate the integrity of the heat pipes.

Beginning in 1989, small samples of heat pipe panels were fabricated by Rocketdyne as part of the CSTI program. The next phase of the program will involve fabrication and testing of complete heat pipes about a meter long.

The working fluids and temperatures for the SP-100 system would be different than for lower temperature RFC systems. Thus, Rocketdyne has an on-going IR&D effort which involves development of a high pressure water C-C heat pipe for lower temperature applications such as RFCs. This effort will eventually include fabrication and testing of a heat pipe. Rocketdyne is also looking at a higher thermal conductivity C-C heat pipe design.

Recent Rocketdyne studies have shown that a C-C heat pipe with water or ammonia is competitive on a mass basis with early metal heat pipe radiator technology developed in the late 1960s and early 1970s as well as pumped loop radiators. Rocketdyne studies have estimated the C-C radiator specific mass to be about 3 kg/m².

The objective of the joint NASA LeRC/Air Force program with PNL (Light Weight Advanced Ceramic Fiber [ACF] Heat Pipe Radiators) is to demonstrate the feasibility of a low mass ceramic fabric/metal liner heat pipe for a wide range of operating temperatures and working fluids (Ref. D-19). Specifically, the NASA LeRC objectives are to develop this concept for application to space radiators with operating temperatures below 500 °K using water as the working fluid. The specific mass goal for these heat pipes is 3 kg/m² or less at a surface emissivity of greater than 0.85.

Several heat pipes were built for the ACF program using titanium and copper foil material for containment of the water working fluid. A heat pipe with a 0.2 mm Ti liner was demonstrated in early January 1991. An innovative "Uniskan Roller Extrusion" process has also been developed at PNL and used to draw 0.76 mm wall tubing to a 0.2 mm foil liner in one pass. The water heat pipes fabricated for LeRC have been subjected to a test program to evaluate performance and reliability at demanding operating conditions.

Future thrusts of the ACF program will be to perfect the heat pipe fabrication procedure using very thin (0.025 to 0.05 mm) foil liners which are internally texturized by exposure to high pressures (Ref. D-19). Plans will also be developed to perform hyper-velocity and ballistic velocity impact tests in order to determine if secondary fragments from a penetrated heat pipe will result in failures of neighboring heat pipes. Another major challenge will be to design a heat pipe with high conductivity, low mass fins as a first step toward the fabrication of low mass radiator panels.

The NASA LeRC in-house materials program includes radiator surface morphology alteration by arc texturing for emissivity enhancement purposes (Ref. D-19). Emissivity enhancement has been demonstrated for graphite-copper samples.

Another important part of the thermal management subsystem is the active controls for controlling fluid flowrates and pressures. This involves the development of long life pumps, valves, and regulators. Hamilton Standard has used 2.07×10^7 N/m² (3,000 psi) water pumps for its U.S. Navy electrolysis units (made by J.C. Carter Company per Ref. D-11). These

pumps have lasted over 10,000 hours. Hamilton Standard also has used a small 0.91 m³/h (4 GPM) pump for recirculating water to a fuel cell which lasted over 10,000 hours. Existing active convective transport hardware (pumps, centrifugal water separators, fans) have also been developed for space systems by GE and Hamilton Standard, but not for long life (Ref. D-8). Experts in the field believe that these components will have lifetimes of less than 2,000 hours in a space environment.

RFC Water Management Subsystem State-of-the-Art

Water management involves both gas humidification to maintain proper cell membrane moisture content as well as gas dehumidification to prevent water condensation and freezing. Work has been done in both of these areas, but not for space qualified hardware.

Gas humidification for production PEM fuel cells has been successfully done by Hamilton Standard using the approach shown in Figure D-6. An improved approach which removes oxygen from the product water was shown in Figure D-4. This approach was demonstrated in the laboratory in 1989, outside of a fuel cell (Ref. D-11). This approach has not yet been integrated into a PEM fuel cell design.

Water vapor can be removed from gases using condensation, absorption, adsorption, or a combination of these techniques. Gas drying is a well-known technical process. General Dynamics proposed (Ref. D-20) a system which utilizes condensation for removing 99.9% of the moisture from oxygen and hydrogen gases. The removal of the remaining moisture was assumed to be accomplished using absorption-adsorption techniques in existing ground liquefaction systems. General Dynamics adapted a system developed by Atlas Copco called MD sorption drying for propellant processing. This process recovers all of the water during the electrolysis portion of the cycle. However this is a very complex system with many moving parts (pumps, valves, and rotor in sorption dryer). In addition, this system increases the radiator size by reducing the heat rejection temperature.

Work was done with regenerative gas dryers for Hamilton Standard by the UTC Research Center in 1987 (Ref. D-11). These dryers use a molecular sieve to remove water. In tests, a humidified gas stream was run through a dryer bed for 36 hours without breakthrough. A 10% bed loading (amount of bed volume which was water) was achieved. An outlet dew point of less than minus 183 °K was obtained with a 100 to 1 gas volume ratio. Such a dryer removes about 99.9% of the water vapor from a gas. Based on this work, a 21 kg desiccant could be made regenerable and deliver 2,939 kg of dry gas (about twice that required for a 12.5 kW lunar base system). A much smaller unit would be required for a Mars system. Hamilton Standard has also looked at methods to reduce dew point temperature down to liquid hydrogen temperatures.

RFC Reactant Storage Tank State-of-the-Art

Gas storage tanks have had considerable engineering advancement, both in earlier NASA programs and throughout the commercial sector. Gas tanks have become safe, reliable commodities, widely used in science and technology. Composite tanks with a metallic liner and a polymer wrap are generally considered for advanced space applications.

Composite tanks have had considerable recent development for a wide range of sizes (Ref. D-21). Structural Composite Industries (SCI) has built many tanks for both terrestrial and space applications. These cylindrical tanks have either aluminum or stainless steel liners. These liners are seamless and are made from plate stock without welding. SCI has developed tanks for Space Station, Brilliant Pebbles, HEDI, propellant tanks for launch vehicles, communications satellites, and Pegasus projects among others. Eleven of these tanks have been launched into space. Tank sizes have ranged from 754 cm³ to 0.66 m³ (Space Station). A recent effort involved a tank which is 4.06 m long and has a 0.53 m outer diameter. A current effort involves the development of a 1.42 m diameter tank. Tank pressures have gone as high as 1.034x10⁸ N/m² (15,000 psia) for operation and 2.068x10⁸ N/m² (30,000 psia) for burst.

Tanks for SDI missions are designed for 5 year life. Additional liner development may be required for storage of wet oxygen.

PP&C Subsystem State-of-the-Art

The PP&C system design is based on a reasonable electronics component evolution, and there are no significant technology issues associated with its development. It will be necessary to fabricate breadboard hardware for testing and evaluation purposes, but there is no need to initiate any advanced component development. Most of the hardware elements have been or shortly will be operating in a relevant environment on other spacecraft or the SSF electrical power subsystem.

DEVELOPMENT PLANS

The development program was divided into eleven major tasks. The first eight tasks are component development tasks. The last three tasks includes the system design, fabrication, integration, and testing for the Ground Engineering System (GES), Qualification Unit (QU), and Flight System (FS).

Testing will be done on the component, subsystem, and system level (qualification testing). The system level tests will show any possible negative interactions between subsystems. Additional testing will be done on the lunar surface.

The PV/RFC development tasks are described in the following sections. Each task will include a section on objectives and the statement of work. The task descriptions are only approximate and depend on the PV/RFC design chosen.

Task 1. PV Array Development

Objectives: Complete development of high efficiency tandem cell, a low mass flexible array, and an automatic or robotic deployment approach.

Statement of Work: The following subtasks are identified:

Task 1-1 Subscale PV Array Development - Complete development of GaAs/CIS or advanced (AlGaAs/CIS) tandem cell. Develop larger cell size. Test subscale PV panels to verify performance under appropriate environmental conditions (thermal cycling, vibration tests, strength and stiffness, radiation, etc.). Develop array structure and deployment concept.

Task 1-2 Full Scale PV Array Development - Develop and test full scale PV arrays. Verify adequate performance.

Task 2. PEM Fuel Cell Module Development

Objectives: Develop a full scale flight weight fuel cell module which can be integrated into a mobile RFC power system. Demonstrate materials compatibility, safety, and performance.

Statement of Work: This effort was divided into the following subtasks:

Subtask 2.1 Preliminary Fuel Cell Module Development - Demonstrate the feasibility of the selected fuel cell design for planetary surface applications. Investigate stack sealing materials, plates, membranes, humidifier, and diluent control. Test a prototype fuel cell stack to demonstrate performance, materials compatibility, and safety.

Subtask 2.2 Final Fuel Cell Module Design - Design a full scale flight weight fuel cell modules (one or more different sizes).

Subtask 2.3 Fuel Cell Module Fabrication, Assembly, and Testing - Build and test (performance, mechanical, and thermal cycling) the fuel cell module. After initial breadboard validation testing is complete, perform additional module testing in a relevant environment.

Task 3. PEM Electrolysis Cell Module Development

Objectives: Develop a full scale flight weight electrolysis module which can be integrated into a mobile RFC power system. Demonstrate materials compatibility, safety, and performance.

Statement of Work: This effort was divided into the following subtasks:

Subtask 3.1 Preliminary Electrolysis Cell Module Development Design - Demonstrate feasibility of the selected concept for space applications. Investigate options for the cell

membranes, pressure vessel, central fluid plate, and electrical connections. Demonstrate materials compatibility, performance, and safety using a prototype cell stack.

Subtask 3.2 Final Electrolysis Module Design - Design a full scale flight weight electrolysis cell module.

Subtask 3.3 Electrolysis Module Fabrication, Assembly, and Testing - Build and test (performance, mechanical, and thermal cycling) the full scale electrolysis cell module. After initial breadboard validation testing is complete, perform additional module testing in a relevant environment.

Task 4. Thermal Management Subsystem Development

Objectives: Develop and demonstrate a low mass, reliable heat pipe radiator. Develop and demonstrate long-life active thermal control components (pumps, valves, regulators, etc.), as needed. Develop and demonstrate thermal control concepts for all components in the RFC system.

Statement of Work: This effort was divided into the following subtasks:

Subtask 4.1 Heat Pipe Demonstration - Fabricate and test representative length heat pipes to fully characterize heat pipe performance. Compare test results with predicted performance over the anticipated range of operating conditions including startup, shutdown, and restart.

Perform limited life testing of the heat pipes. Identify deterioration mechanisms, measure deterioration rates, and assess the adequacy of assembly and cleaning procedures. Withdraw heat pipe samples sequentially throughout the test period. Drain, section, and analyze the samples for corrosion, carbon diffusion, braze stability, and any other signs of deterioration.

In conjunction with the heat pipe performance and life testing, develop and demonstrate techniques for nondestructive examination (NDE) of the heat pipe elements and assembly.

Assess the adequacy of liner bonding and weld joints. Determine if the correct fit-ups and interfaces were obtained in the assembled piece.

Subtask 4.2 Radiator Enhancement - Increase the applicability of the radiator concept by performing various enhancement tasks. Examine survivability options and extended length heat pipes.

Perform analytical assessment, testing, and enhancement design development to insure long life for both lunar and Mars missions. Consider natural threats such as micrometeoroids and dust erosion (Mars).

Fabricate a long heat pipe. Develop alternate techniques for fitting the liner into the tube. Investigate alternative tube fabrication, liner fabrication, and coating processes.

Subtask 4.3 Heat Pipe Integration and Testing - Develop and demonstrate techniques for thermal and mechanical bonding of the heat pipe to the radiator manifold. Subsequently, demonstrate heat pipe integration into a representative radiator section. Test the radiator section to provide an accurate overall heat transfer coefficient. Verify radiator dynamics and performance. Include a surrogate manifold section and a limited number of heat pipes in the demonstrator. Test the assembled unit in a cold wall, vacuum chamber, simulated space environment. Validate temperature drop predictions, verify manifold design, and assess component interactions.

Subtask 4.4 Radiator Module Design, Assembly, Fabrication, and Testing - Develop the detailed design of the radiator subsystem. Resolve specific design issues such as the effects of differential thermal expansion, deployment features, monitoring instrumentation and control equipment, local insulation, and trace heating of the manifold and piping.

Design, fabricate, and test a representative full scale heat pipe radiator and interface heat exchanger. Complete performance, mechanical (stress, shock, and vibration), and thermal cycling tests.

Subtask 4.5 Preliminary Active Component Development - Perform preliminary development of water circulation pumps and other active fluid components. Identify life limiting components and failure mechanisms of current designs. Develop design approaches with improved life capabilities. Design and build prototype components. Demonstrate materials compatibility, safety, and performance margins.

Subtask 4.6 Final Active Component Design - Design the full scale components and develop the active control subsystem concept.

Subtask 4.7 Active Control Subsystem Fabrication, Assembly, and Testing - The final components will be designed and integrated into a fluid subsystem test bed with simulated thermal loads and pressure drops for other RFC components. Testing shall include performance, shock, pressure, and safety tests. After initial breadboard validation testing is complete, perform additional testing in a relevant environment.

Task 5. Water Management Subsystem Development

Objectives: Develop regenerative dryers for removing water vapor from the electrolyzer product gases. Develop an approach for recovering water from dryers. Develop a reactant gas humidification device for the fuel cell for maintaining a proper membrane moisture content.

Statement of Work: This effort was divided into the following subtasks:

Subtask 5.1 Gas Dryer Development - Develop regenerative gas dryers for use with wet hydrogen and oxygen gas streams. Design the dryers to remove the majority of the water vapor from the gas streams with reasonable size and mass hardware. Build prototype dryers. Test the dryers in the adsorption and desorption modes. Determine materials compatibility, regenerability, cyclic performance degradation, and efficiency.

Perform studies to determine the effect on system performance of any remaining moisture after leaving the regenerative dryers. Design an approach for recovery of the remaining moisture from the gas system. Develop additional components as necessary to handle

this remaining moisture. Demonstrate analytically and empirically the performance of this additional hardware.

Subtask 5.2 Gas Humidifier Development - Complete the development of reactant humidifiers which are integral to the fuel cell. This will include modification of existing humidifier concepts which currently work external to the fuel cell. In addition, this task will be done in parallel with fuel cell development to allow for proper integration with the fuel cell stack design.

Task 6. Reactant Storage Tanks

Objectives: Develop reactant tanks for storage of wet hydrogen gas, wet oxygen gas, and water. Develop tank and tank feed line thermal management (insulation and/or heat recovery from fuel cell stack) approaches to prevent composite tank failure, and prevent ice blockage of gas lines and regulators.

Statement of Work: Design, fabricate, and test the reactant storage tanks. Develop corrosion resistant liners and fabrication techniques for the oxygen and water tanks. Consider the requirements for micrometeoroid protection in the tankage design.

Develop insulated and/or heated tank concepts which prevent water condensation and freezing in the gas storage tanks and exit lines. Demonstrate proper transient performance of the tanks using analysis techniques. Build and test prototype tanks. Demonstrate materials compatibility and safety. Perform proof testing, thermal cycling (while under pressure), puncture resistance, and mechanical shock tests. Measure tank permeability to estimate leakage losses, especially for hydrogen.

Task 7. PP&C Subsystem Development

Objectives: Develop electronic components for controlling system operation, maintaining constant output voltage, and for eliminating excess solar energy. Demonstrate adequate steady state and transient performance, and immunity to the environment (including launch and

operating). Demonstrate the software capability to handle power system nominal operation and failure modes.

Statement of Work: This effort was divided into the following subtasks:

Subtask 7.1 Electrical Components - Build breadboard units to demonstrate and check functional performance of the individual component circuit designs. Incorporate any necessary design modifications and improvements into brassboard units. Verify functional performance within the constraints of the actual component configuration. Fabricate prototype units and perform a series of tests using simulated input and output loads. Test the controller to validate the operating system software. Include the following testing:

- start up, steady state and transient control;
- failure simulation and detection and switching;
- effects of temperature extremes and thermal shock;
- effects of environment;
- shock and vibration;
- cold plate heat loads; and
- EMI generation and susceptibility.

Subtask 7.2 Software - Check out the controller software using simulated inputs and outputs.

Task 8. Ground Engineering System (GES) Testing

Objectives: Design a system concept which will meet both lunar and Mars mobile power applications. Show the concept feasibility. Verify adequate performance and life for an integrated system.

Statement of Work: This effort was divided into the following subtasks:

Task 8.1 GES Design - Identify and characterize specific power system applications. Determine power system requirements. Define optimum power system module

size based on trade studies which minimize the overall life cycle cost of the power system for all applications (trade between development cost and mass).

Identify concepts which can meet early lunar base applications. Power system enhancements, if any, required for Mars applications will be identified. Perform tradeoff studies (performance, reliability, risk, safety, and life cycle cost) to select the optimum system design. Complete feasibility studies for the selected concept including off-design and transient analysis. Definitize the remaining hardware development tasks based on the system concept chosen.

Design a complete power system to at least meet the minimum life requirement (10 years for the arrays and 20,000 hrs for the RFC with a 50% duty cycle for electrolysis and fuel cell stacks). Integrate the entire RFC thermal and water control system including pumps, controls, lines, valves, heat exchangers, tanks, and radiator. Perform both design point and transient analyses to verify the design. Perform this task in parallel with the component development tasks to insure proper system characteristics

Task 8.2 GES Performance Tests - Manufacture the GES components and assemble. Pressure and leak check the assembly, fill the water storage tank, complete a electrical check-out, and check out all active devices to the extent possible.

Design the test program for the GES to verify all performance characteristics of the unit in conjunction with subjecting the GES to acceptance level tests. Conduct performance and thermal vacuum tests during a single thermal vacuum test sequence to demonstrate technical capabilities while minimizing program cost. Complete the following performance testing activities:

- checkout and refine subsystem assembly procedures;
- verify operation of ground support equipment (GSE) and interfaces with the GES;
- verify start up capability;
- verify steady state performance characteristics;
- establish effective operating range of the system;

- check out software and verify autonomy (include all operational modes and simulate failure modes);
- simulate normal switchover from one module to another;
- simulate failures to trigger module switchover; and
- establish system sensitivity to off-normal conditions such as: (1) partial loss of radiator cooling, (2) varying radiator heat removal profile, (3) partial loss of electronic cooling, and (4) temporary losses of heat sink with varying duration.

Task 8.3 GES Life Test - Refurbish the GES after completion of performance,

acceptance, and margin tests. Refurbishment will include the following:

- replacing or repairing components as necessary to ensure that the GES is returned to its as-built condition;
- addition of special instrumentation required for the life test phase; and
- modification of the main radiator heat removal system or replacement of the main radiator with a dump heat exchanger.

Install instrumentation to provide a comprehensive diagnosis of the "health" of the GES and to monitor for degradation of major assemblies and individual components. Place the GES on a multiyear life test. Operate the GES at its nominal operating point, with expected GES variations in power output and environment.

Disassemble the GES for diagnosis at the end of the life test. Determine areas to be examined by an analysis of the health monitoring data and from the reliability analysis predictions.

Task 9. Qualification Program Testing

Objectives: Fabricate the qualification units (QUs) Verify adequate performance and life for the QUs.

Statement of Work: Develop a comprehensive performance and dynamic testing program which will provide a formal demonstration that the power system will perform as designed after being subjected to simulated launch conditions. Select launch environmental conditions which envelope the probable intensities developed by various launch scenarios.

Begin the qualification effort (a typical approach is shown in Figure D-9) by qualifying the assemblies. Fabricate and assemble the qualified production items into the QU. Qualify the QU by the rules for space vehicle qualification.

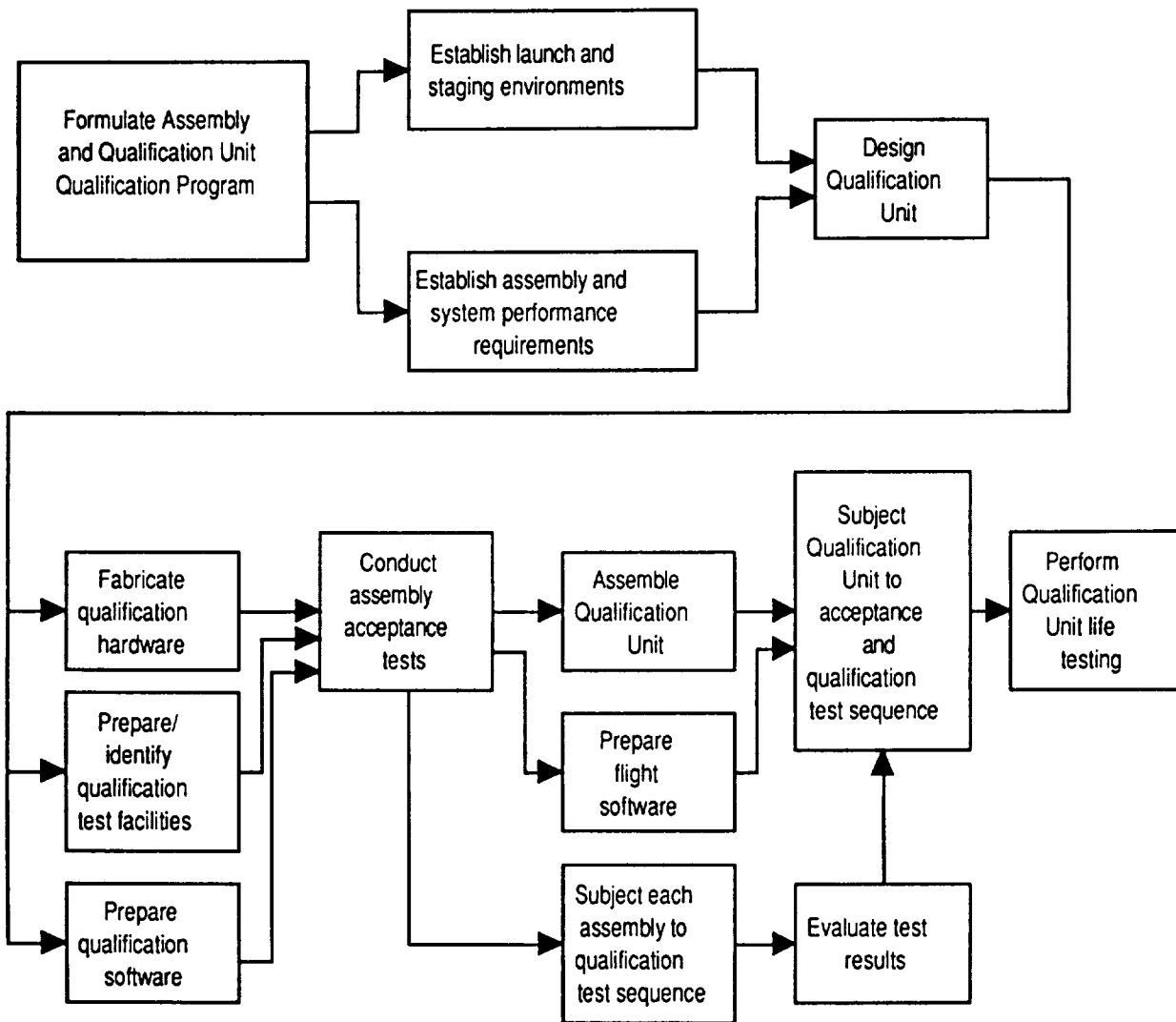

Figure D-9. PV/RFC power system qualification program.

This effort was divided into the following subtasks:

Subtask 9.1 Qualification Performance Testing - Conduct performance testing at each level to verify that each item performs as designed. Perform dynamic testing to verify the capability of the RFC system to withstand launch loads, including acoustic, pyroshock and

vibrational. A possible performance and dynamic qualification test sequence for components and assemblies is shown in the matrix of Figure D-10. The corresponding qualification test sequence for the QU is shown in Figure D-11.

Component or Subassembly	Functional (1)	Leak	Pyroshock	Functional (2)	Random Vibration	Functional (1)	Leak	Acceleration	Functional (1)	Thermal Cycling	Functional (2)	Thermal Vacuum	Functional (2)	Pressure	Leak	EMC	Life	Functional (1)
Fuel Cell Stack	X	X			X	X	X			X	X	X	X	X	X	X	X	X
Electrolysis Cell Stack	X	X			X	X	X			X	X	X	X	X	X	X	X	X
Reactant Storage	X	X	X	X	X	X	X			X	X	X	X	X	X		X	X
Thermal Control	X	X			X	X	X					X	X	X	X		X	X
Radiator and Manifold	X	X			X	X	X			X	X	X	X	X	X		X	X
PMAD	X		X	X	X	X				X	X	X	X			X	X	X
Structure	X		X	X	X	X		X	X	X	X						X	X
PV Array	X		X	X	X	X				X	X	X	X			X	X	X

Figure D-10. PV/RFC power system assembly qualification test matrix.

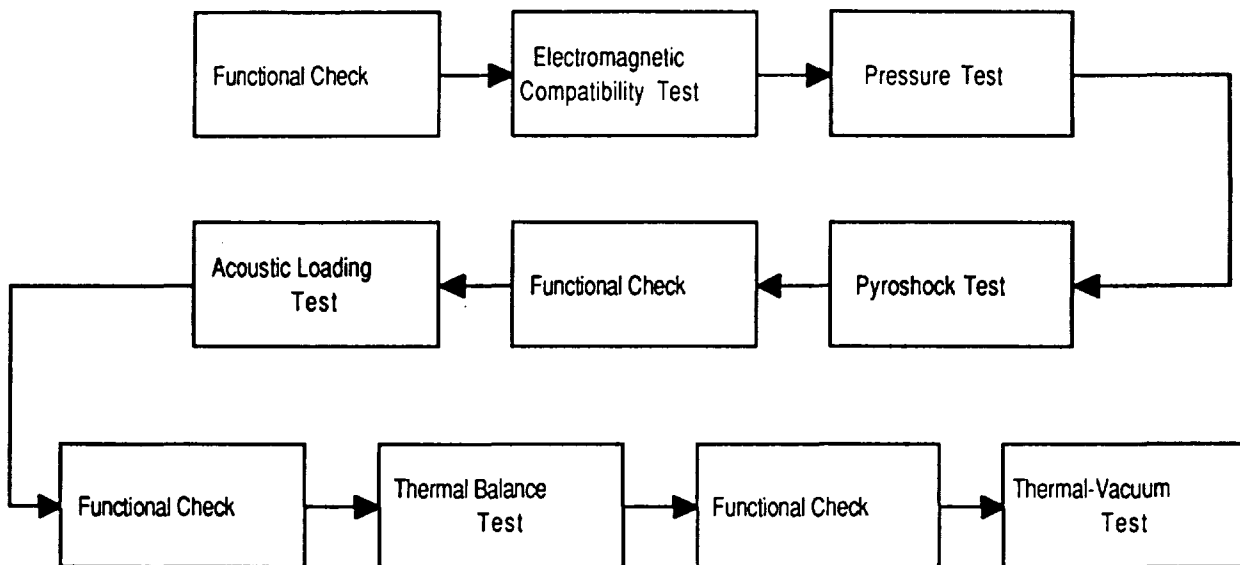

Figure D-11. PV/RFC power system QU test sequence.

Subtask 9.2 Qualification Life Testing (Optional) - After completion of the qualification performance testing, partially disassemble the QU and examine the unit. Refurbish the QU as required and modify for endurance testing in air, as described for the GES. Life test the QU for 20,000 hours or more.

Task 10. Flight Unit (FU) System Program

Objectives: Fabricate the flight systems and acceptance test the FUs to demonstrate required performance. Deliver the flight systems and provide integration support for the FU with the payload and the launch vehicle.

Statement of Work: Fabricate, acceptance test, and assemble parts to produce the flight systems. Subject the systems to acceptance testing before shipment to the launch site. Use the same test facilities (vacuum chamber, vibration, acoustic) that were used for the qualification program for flight system acceptance testing. Perform safety studies and complete safety reports necessary to obtain launch approval. Finally, provide launch support activities to insure that the FU meets its design and performance goals associated with integrated payload and launch systems.

PHOTOVOLTAIC/REGENERATIVE FUEL CELL POWER SYSTEM TECHNOLOGY ROADMAP

The work is divided into the following subtasks:

Subtask 9.1 Flight Component Fabrication. - Design, fabricate, inspect, and assemble the components and subassemblies required for the FUs, including all spare parts as required to support the flight system activities.

Subtask 9.2 FU Assembly, Test, and Payload Integration - Assemble and inspect the FUs. Acceptance test the FUs and ship to the launch site. Provide technical support for FU integration with the payload, launch vehicle, and launch support facilities.

Subtask 9.3 FU Launch Support - Provide FU launch support activities to insure that the FU meets its design and performance goals associated with the integrated payload and launch systems.

DEVELOPMENT SCHEDULE

The program starts with a conceptual design task followed by preliminary design and concurrent component development of the PV array, RFC (fuel cell stack, electrolysis cell stack, active controls, gas dryers, and tanks), radiator, and PMAD. The detailed design is subsequently completed by the middle of the fourth year.

Fabrication of components for ground testing for the Ground Engineering System (GES) starts with procurement of long lead materials and equipment in the first part of the third year. This leads to assembly of the system by the end of the fourth year.

The GES will be similar to a flight system but will have features such as additional instrumentation and readily removable components to expedite gathering of engineering data and to permit modification of components. It will be tested in a vacuum chamber under normal and off-normal design conditions. After this phase of testing, it will be partially disassembled, examined, refurbished as necessary, and put on life test for 20,000 hours (50% duty cycle for the fuel cell and electrolysis cell stacks).

The qualification phase includes design, fabrication, assembly, and qualification testing of individual components, and a complete system. The design effort will be minimal since it would involve only minor modifications to the GES design.

The flight phase of the program includes fabrication, assembly, and acceptance testing of the flight units and the associated safety analysis to obtain launch approval.

The estimated development and production schedule for the PV/RFC power system is shown in Figure D-12. The development time to achieve a flight proven system is estimated to be 7 years. If the program is initiated in FY'93, then power systems could be available for early lunar missions.

PHOTOVOLTAIC/REGENERATIVE FUEL CELL POWER SYSTEM TECHNOLOGY ROADMAP

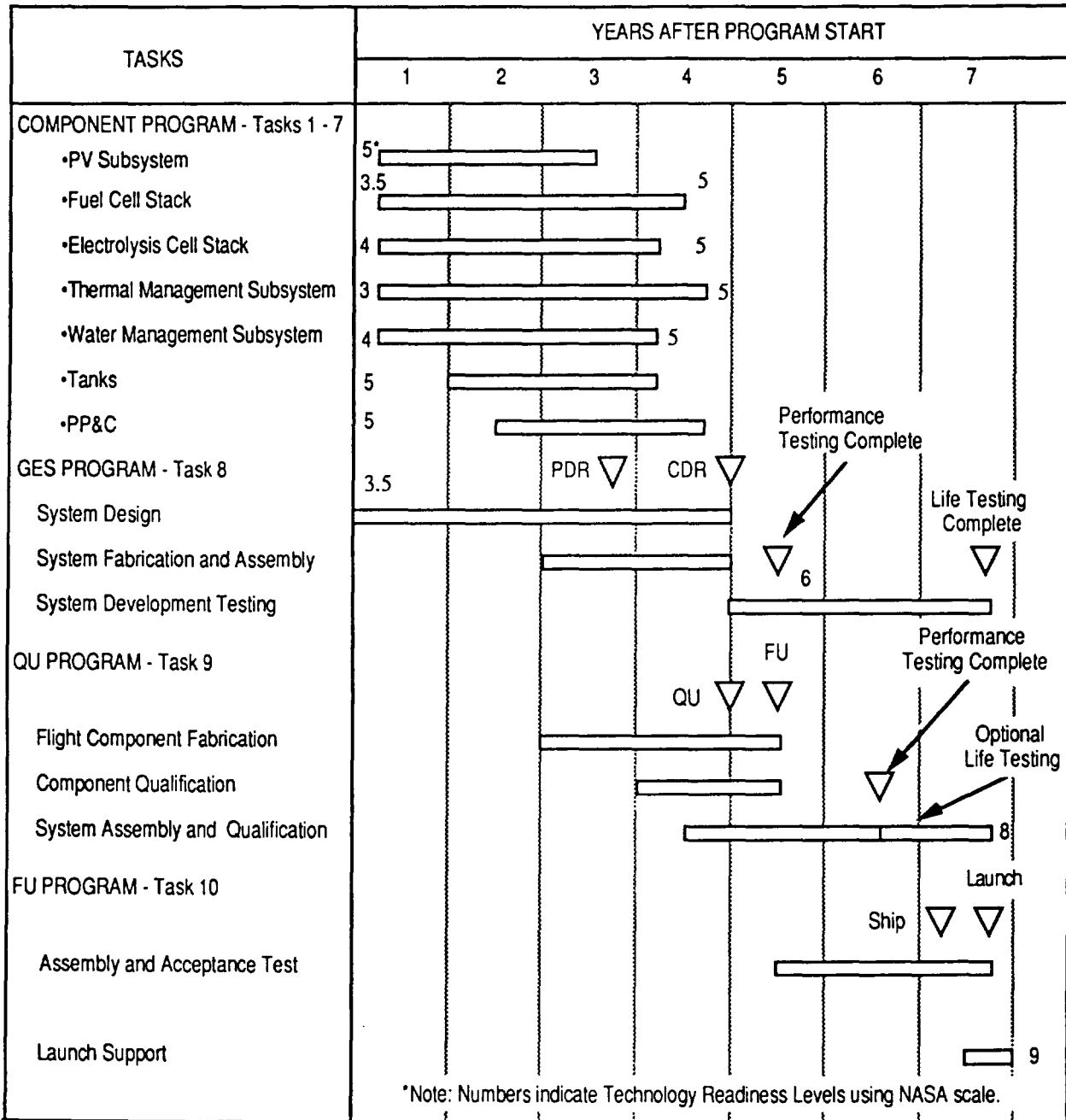

Figure D-12. PV/RFC power system development schedule.

REFERENCES

- D-1. McElroy, J.F.: SPE Water Electrolyzers in Support of Mission From Planet Earth. Space Electrochemical Research and Technology Conference, NASA conference publication 3125, April 1991.
- D-2. Kim, N.P.; and Devaney, N.E.: Low Cost CuInSe₂ Based Solar Cells for Space Application. 26th IECEC Proceedings, Volume 2, August 1991, pp. 314-320.
- D-3. Kim, N.P.; et. al: High Specific Power (AlGaAs)GaAs/CuInSe₂ Tandem Junction Solar Cells for Space Application. 24th IECEC Proceedings, Volume 2, August 1989, pp. 779-783.
- D-4. Stanbery, B.J.; et. al: Thin Film GaAs/CuInSe₂ Solar Cells for Space Power Application. 19th IECEC Proceedings, August 1987, pp. 280-284.
- D-5. Landis, G.A.: Review of Thin Film Solar Cell Technology and Applications for Ultra-Light Spacecraft Solar Arrays. Proceedings of the 10th Space Photovoltaic Research and Technology (SPRAT) Conference, 1989, pp. 180-197.
- D-6. Cooley, Lt. W.T.: Air Force Photovoltaic Array Alternatives. 26th IECEC Proceedings, Volume 2, August 1991, pp. 275-280.
- D-7. Stella, P.M.; and Kurland, R.M.: Development of the Advanced Photovoltaic Solar Array. 26th IECEC Proceedings, Volume 2, August 1991, pp. 269-274.
- D-8. Technology Assessment and Tradeoff Study of Fuel Cell and Electrolyzer Technology for Project Pathfinder Energy Storage System. Preliminary report to NASA Lewis Research Center, Los Alamos National Laboratory, February 1991.
- D-9. McElroy, J.F.: SPE Regenerative Hydrogen/Oxygen Fuel Cells For Extraterrestrial Surface Applications. 24th IECEC Proceedings, August 1989, pp. 1631-1636.
- D-10. McElroy, J.F.; et. al: SPE[®] Regenerative Hydrogen/Oxygen Fuel Cells For a Lunar Base Power System. 25th IECEC Proceedings, August 1990, Volume 3, pp. 143-148.
- D-11. Personal Communications with Jim McElroy at Hamilton Standard. Rockwell International (Rocketdyne Division), Frank Littman, 8/13/91, 9/12/91, 9/23/91, 1/31/92, and 3/25/92.
- D-12. Pesaran, A.A.: Silica Gel Sorption Properties under Adiabatic Conditions. Solar Energy Research Institute report no. SERI/TR-252-2704, February 1986.
- D-13. Penny, T.R.; et. al: Capacity Degradation of Field-Tested Silica Gel Samples. Solar Energy Research Institute report no. SERI/TP-252-2741, June 1985.
- D-14. Kim, N.P.: Personal Communications. Boeing Defense and Space Group, Seattle, WA, 10 September 1991 and 3 October 1991.
- D-15. Srinivasan, S.; et. al: Recent Advances in Solid Polymer Electrolyte Fuel Cell Technology with Low Platinum Loading Electrodes. 24th IECEC Proceedings, Vol. 3, August 1989, pp. 1623-1629.

REFERENCES

- D-16. Lawrance, R.J.; and Margiott, V.A.: Proton Exchange Membrane Fuel Cell Development. 24th IECEC Proceedings, Vol. 3, August 1989, pp. 1587-1591.
- D-17. Meyer, A.P.: Status of Solid Polymer Fuel Cell Power Plant Development at International Fuel Cells Corporation. 24th IECEC Proceedings, August 1989, pp. 1619-1622.
- D-18. Personal Communications with Jay Stedman at International Fuel Cells. Rockwell International (Rocketdyne Division), Frank Littman, September 13, 1991.
- D-19. Juhasz, A.J.: An Overview of the LeRC CSTI Thermal Management Program. Paper no. AIAA-91-3528, AIAA/NASA/OAI Conference on Advanced SEI Technologies, September 4-6, 1991.
- D-20. Bock, E.H.; and Fisher, J.G.: In-Space Propellant Processing Using Water Delivered as Shuttle Contingency Payload. AIAA Paper 78-941, July 1978.
- D-21. Personal Communications with Ian Devey of Structural Composites Industries. Rockwell International (Rocketdyne Division), Frank Littman, October 9, 1991.

APPENDIX E

INTRODUCTION

This is a family of fixed power systems for Mars applications. Mission applications require power levels from 0.9 kWe to 75 kWe. Power system applications include communications (0.9 kWe), emergency power (5 kWe), the excursion vehicle servicer (10 kWe), and exploration site main power (25 kWe and 75 kWe modules for habitat and associated external equipment). Solar powered systems such as these will require energy storage for operation at night.

CONCEPT DESCRIPTION

A typical power system schematic is shown in Figure E-1. The overall power system may be divided into the following subsystems for development purposes:

- Photovoltaic (PV) Array;
- Batteries;
- Thermal Management; and
- Power Processing and Control (PP&C).

The solar array converts sun light directly into DC electricity. The energy from the array flows to the batteries, for later use, and to the user. When the system enters a period of darkness, the energy to the user is supplied by the batteries. The batteries are recharged on the next sun cycle by the solar array. The flow of energy from the array and to and from the batteries is controlled by the PP&C subsystem.

Since the batteries must operate at high temperature, thermal management is required to maintain the proper cell temperature and reject waste heat. In addition, the batteries need to be heated prior to startup. The electronic components in the PP&C also require cooling to remove waste heat.

This power system concept utilizes high efficiency photovoltaic cells to minimize array area. A large array area is required for Mars applications due to the low insolation rate (due to

dust from local and global dust storms). Since the PV subsystem is the largest component of system mass for Mars systems, it is important to minimize array area and specific mass (kg/sq m).

The PV subsystem includes the array panels, support structure, and wiring harness. For development purposes, specific subtasks will include cell development, array development, deployment mechanism development, and integration/system testing.

The battery subsystem includes the cells and related structure to tie the cells together.

The thermal management subsystem includes battery insulation, battery isolation plates, battery radiator/interface heat exchanger, PP&C cold plates, and the PP&C radiator.

Power conditioning is included to process power for charging the batteries (down regulator) and processing output power (boost regulator). A shunt regular dissipates excess power from the array.

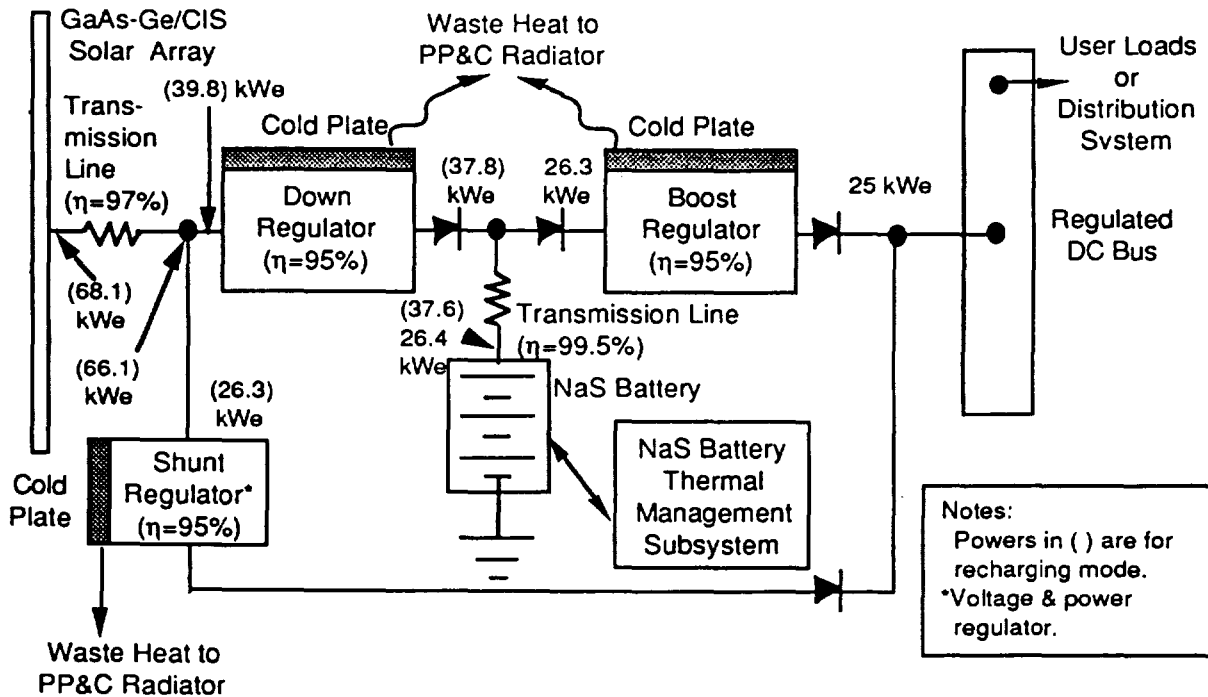

Figure E-1. PV/NaS battery system schematic.

The PV panels are assembled into modules on site. The modules are then connected to the batteries. The battery subsystem housing is a separate unit which includes the PP&C subsystem. The battery/PP&C unit is connected to the arrays after array deployment.

The system evaluated in this article uses advanced multijunction tandem solar cells, sodium sulfur (NaS) batteries, DC-DC converters/regulators, and a heat pipe radiator. Each subsystem will be described in more detail in the following sections.

Solar Subsystem Description

A solar array is made up of panels of photovoltaic cells mounted on a substrate structure. A photovoltaic cell is a semiconductor device that turns light in to direct current electricity (DC).

The baseline PV cell is one being developed by Boeing Defense and Space Group in Seattle (Refs. E-1 through E-3). The multi-bandgap or tandem cell consists of a double-heterostructure GaAs or AlGaAs thin film top cell and a polycrystalline CdZnS/CuInSe₂ heterojunction thin film lower cell as seen in Figure E-2 (Ref. E-1). The leading technology for thin film photovoltaic cells is CuInSe₂ (CIS) (Ref. E-4). In the cascade structure shown, short wavelength (high energy) photons are absorbed in a high bandgap material on top of the solar cell. The high bandgap material is transparent to longer wavelength (low energy) photons which pass through and are absorbed by a second layer consisting of a photovoltaic material with low bandgap.

Cascades can be configured as a monolithic cell in which the top cell is integrally deposited on the bottom cell (or vice versa), or mechanically stacked, in which the two sets of cells are formed separately. A mechanically stacked tandem configuration was chosen by Boeing in order to provide wiring flexibility and to minimize fabrication constraints. Since both cells are deposited as thin films, a very high specific power is possible.

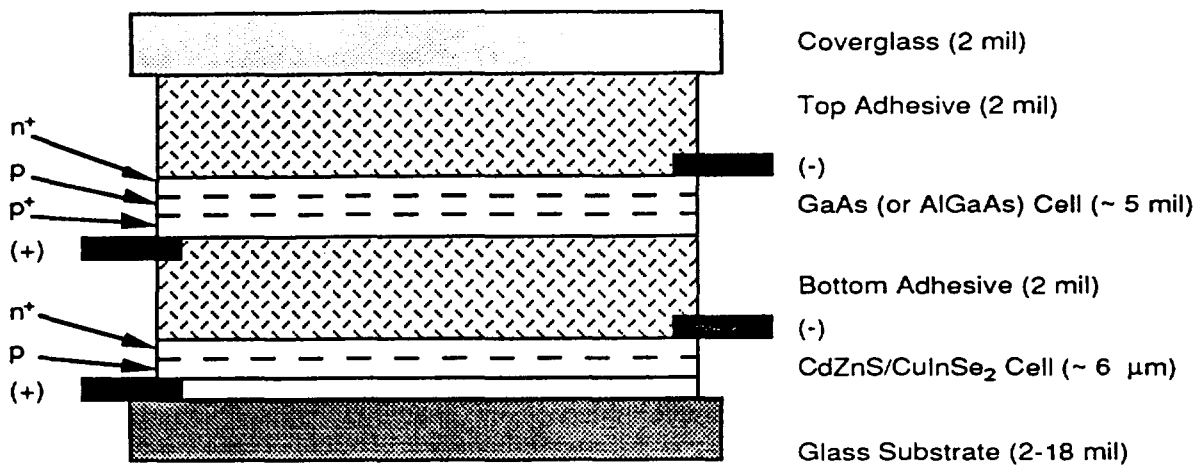

Vertical dimensions not to scale

Figure E-2. Tandem PV cell schematic.

The current Boeing design is based on a 2 cm x 4 cm cell area (Ref. E-1). The cell has an improved two-terminal configuration with voltage-matched monolithic subcell units. Voltage-matching is achieved by stacking one GaAs CLEFT (Cleavage of Lateral Epitaxial Film for Transfer) cell on top of four CuInSe₂ subcells monolithically interconnected in series to form a single cell unit.

An improved cell design could be achieved by using AlGaAs rather than GaAs as the top cell. The bandgap of CuInSe₂ is better matched to the bandgap of AlGaAs than GaAs. A 26% Beginning-of-Life (BOL) cell efficiency at AM0 is projected without structural change for this advanced cell.

The upper thin film cell is fabricated by the CLEFT technique using MOCVD for cell structure growth. The CIS cell fabrication includes sequential depositions of the Mo back electrode, CIS absorber layer, and CdZnS window layer. This is followed by photolithographic patterning and etching to form a solar cell device. Deposition of grid metal and addition of an anti-reflection coating complete the cell fabrication process.

The individual PV panels are either small enough to be transported to Mars as designed or are hinged for easy deployment. The panels lie horizontal and do not track the sun. Trade

studies done by Rocketdyne showed that there was no advantage to tracking arrays since much of the cell input is from diffuse light.

Planar arrays can be subdivided into two broad categories: rigid and flexible (Ref. E-5). Rigid arrays are PV arrays that are mechanically stiffened with a honeycomb structure, usually made of aluminum, sandwiched between two facesheets that provide back side shielding for the PV cells and provide enhanced mechanical support to the structure. Rigid arrays are used in high risk, unknown environments, where weight and cost are a secondary concern. Rigid arrays provide the most mechanical support and the most survivability. However, the rigid array is not suitable for planetary surface applications due to the mass penalty.

Flexible arrays are typically a Kapton substrate/superstrate which sandwich the PV cells and electrical circuitry, and are very attractive due to the significant mass savings over rigid panel arrays. Within the flexible arrays, there are three types: the roll-out type, the fold-out type, and the inflatable type. A flexible array is recommended for SEI surface power applications.

The Advanced Photovoltaic Solar Array (APSA) is an example of future flexible fold-out arrays (Ref. E-6). There are three elements to the APSA array: the flexible plastic and solar cell blanket (50% of the mass), the deployment mast and mast housing (34% of the mass), and the blanket stowage compartment (16% of the mass) (Ref. E-5). The APSA wing consists of a flat fold, multiple panel, flexible blanket on which solar cell modules are installed and connected to printed circuit electrical harnesses that run along the outside longitudinal edges of the blanket assembly. Any type of solar cell can be utilized with the APSA approach. For launch, the accordion-folded blanket is stowed in a graphite/epoxy blanket during launch. The blanket is deployed (unfolded) by extending a motor-actuated, fiberglass, continuous longeron lattice mast that uncoils from an aluminum cylindrical canister structure. APSA is designed for zero g operation. Additional support structure would be required for planetary surface applications.

Inflatable arrays offer promise for missions which are driven by mass and/or the radiation environment. Inflatable arrays require the use of thin film PV solar cells. For a 100 W array (EOL) the mass breakdown is as follows: inflatable torus contributes 0.793 kg, the thin film solar array blanket 0.793 kg, and the support equipment 1.36 kg, resulting in a small satellite array specific power of about 34 W/kg (Ref. E-5).

An array deployment mechanism is required for automatic or robotic deployment. Array deployment alternatives include spring stored "one time deployment" and motor-driven deployment systems. The deployment mechanism is critical from a reliability standpoint and may also contribute significantly to the system mass. The deployment mechanism for Mars systems must also maintain array rigidity during wind storms and must be designed to prevent resonating of the structural due to the natural frequency.

Some form of structure may be used to keep the arrays off the surface or to prevent the arrays from being disturbed by Martian winds. This system would have increased mass over one which is simply rolled out onto the planetary surface.

Battery Subsystem Description

Sodium sulfur batteries are high temperature (598 °K) secondary batteries which have been under development for a number of years. Due to the high theoretical specific energy, these batteries are being considered for electric vehicles, utility load leveling, satellite systems (Ref. E-7), and planetary surface power systems (Refs. E-8 and E-9).

A fully charged sodium sulfur cell consists of elemental sulfur and sodium separated by a beta alumina electrolyte as seen in Figure E-3. Beta alumina is a solid, ceramic electrolyte separator which is conductive only to sodium ions. The molten sodium serves as the negative electrode. During discharge, each sodium atom, entering into the discharge reaction, provides an electron to the external circuit and migrates through the electrolyte. The molten sulfur serves as the positive electrode. The sodium ions receive an electron, from the external circuit, on the sulfur side of the cell and combine with the sulfur to form sodium pentasulfide, Na_2S_5 .

After all the free sulfur is combined, a second conversion takes place in which the Na_2S_5 is converted to sodium trisulfide, Na_2S_3 . The open circuit voltage of the cell during the first 59% of discharge, which corresponds to the sodium pentasulfide reaction, is nominally 2.08 volts per cell. During the sodium trisulfide part of the discharge, the corresponding voltage is 1.75 volts per cell. Thus, the sodium sulfur cell discharge voltage has a two level characteristic with the step change at about 59 percent. Experimental investigation has indicated that for best cycle life, the depth of discharge should be limited to 59 percent.

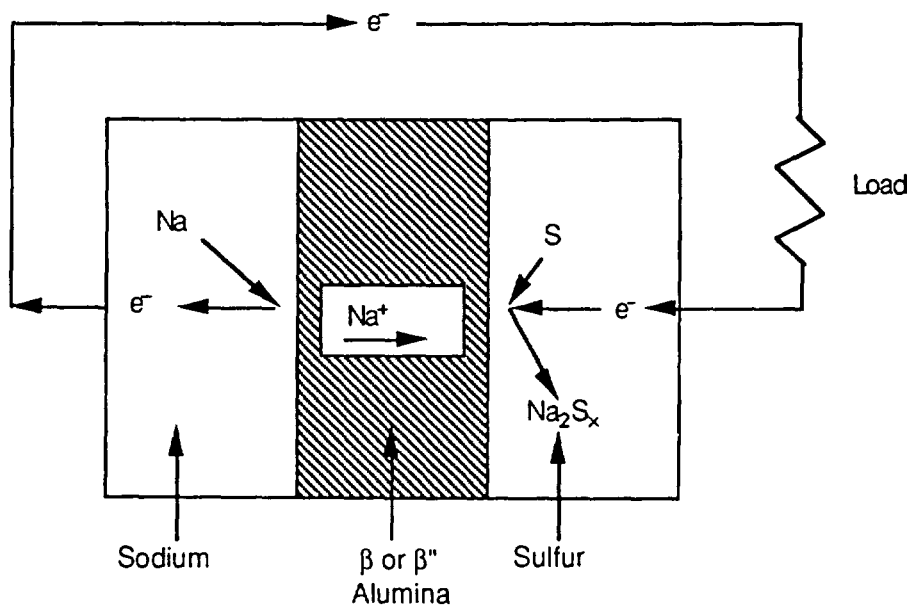

Figure E-3. NaS battery cell operation during discharge.

A tubular type NaS cell is illustrated in Figure E-4. This concept is most suitable for base load power systems (15 minutes to 12 hours of operation). These type of NaS cells have been undergoing evaluation testing by the Air Force for many years and have gone through several design iterations. As shown in the figure, the liquid sodium is contained in a closed steel tube with a metering orifice connecting to an annular chamber also containing sodium. The closed beta alumina electrolyte encloses the sodium and separates it from the liquid sulfur cathode. Liquid sulfur cathode material is held in a carbon felt matrix to provide electrical

conductivity during charge and discharge. The steel tube is coated with a metal chosen for its resistance to the corrosive sodium sulfides.

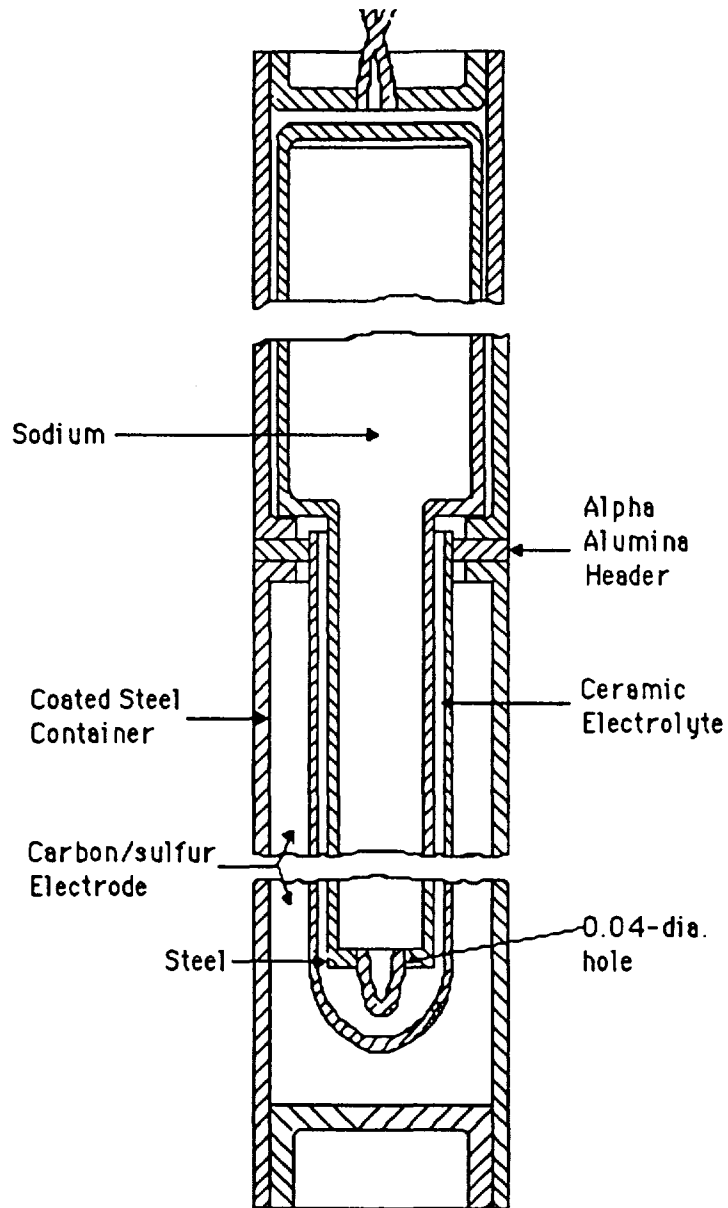

Figure E-4. Typical tubular NaS battery cell design.

Thermal Management Subsystem Description

The thermal management subsystem provides temperature control, heat transport, and heat rejection functions. Solid conduction paths and heat pipes provide the heat transport function. A radiator is required to remove waste heat from the battery and from the PP&C components.

An active thermal control system is required to maintain the battery at the proper operating temperature. Three different techniques are possible for controlling battery temperature (Ref. E-10): (1) louvers; (2) pumped loop radiator; and (3) heat pipe radiator.

The use of louvers allows the battery to radiate directly to space as needed to reduce its temperature. Louvers offer the greatest weight advantage (Ref. E-10). However, louvers require the greatest mechanical complexity and potentially the lowest reliability. Louvers also allow for a nonhomogeneous thermal distribution in the battery which may be detrimental.

Pumped loop (or tube-sheet) radiators offer the next best approach from a mass standpoint if no redundancy is built into them. Pumped loop radiators have been used successfully for the space shuttle and will be used for Space Station Freedom (SSF). This type of radiator is best applied to missions with limited duration or to systems which are serviceable. Potential working fluids include water, potassium, NaK, and Dowtherm A. NaK is the preferred working fluid for this application due to its low freezing point, low operating pressure, and stability in a thermal environment. The use of NaK as a reactor primary coolant indicates that it can be used with good reliability for prolonged periods of time. The development of highly reliable, long life, low flow rate, low mass pumping systems to accommodate the use of fluid loops in space would require considerable effort (Ref. E-10). Furthermore, the pump represents the source of a single point failure mode, thus requiring duplication within the system and thereby nullifying the slight mass advantage over heat pipes.

Thermal homogeneity could be accomplished with heat pipe systems for transport and heat rejection due to their isothermal heat transport characteristics. Heat pipes also offer the advantage of improved reliability and a graceful failure mode. A recent Rocketdyne study has

shown that advanced carbon-carbon (C-C) heat pipe radiators can be designed which are competitive in mass to pumped loop radiators (estimated specific mass of 3 kg/m² for heat pipes with water or ammonia). Thus, a heat pipe radiator was tentatively selected as the baseline design.

The baseline heat rejection assemblies utilize lightweight, passive, reliable, heat pipe radiators that are sufficiently versatile to allow integration into a variety of configurations. The individual heat pipes operate independent from one another and thus the failure of a heat pipe will not result in failure of the complete radiator. The rectangular radiator heat pipe panel is attached to the battery assembly. Variable conductance heat pipes transfer heat to the radiator. The heat pipe working fluid evaporates and travels to the top end of the heat pipes. The evaporated fluid is then condensed in the cooler section of the heat pipe. A small wick or grooves allow the liquid to return to the evaporator (unless the heat pipe is vertical and gravity can be used for fluid return). A wick or groove is not absolutely necessary for vertically oriented radiators (due to gravity return) but is recommended to insure good control of the fluid transport. The heat pipes may be either carbon-carbon tubes with metal liners (titanium or nickel based alloy for biphenyl) or metal heat pipes. Carbon-carbon heat pipes are a factor of 2-3 times lower in mass than conventional all-metal heat pipes.

The problem with using a heat pipe for battery cooling is that no common heat pipe working fluid is suitable for operation at about 600 °K (Ref. E-11). Only three of the common heat pipe working fluids including water, cesium, and mercury show any promise for operation at this temperature. However, these fluids have several disadvantages. Both mercury and cesium are highly toxic and would have handling problems. Mercury has a poor contact angle and does not wet the wick surface, which causes heat pipe priming problems. Mercury also has a high density which results in a heavy heat pipe. Cesium has a very low vapor pressure which favors leakage into the pipe. Leakage is a severe problem since atmospheric water will react with the cesium to form hydrogen. Water develops a high pressure at the required operating pressure which requires a heavier heat pipe and may result in potential safety issues. A recent

study (Ref. E-11) found that biphenyl is a suitable heat pipe working fluid for this application. Biphenyl is compatible with likely materials of construction and its liquid transport factor is suitable for use in a heat pipe. Also, its vapor pressure is in the desired range at the operating temperature of the battery. Thermal studies have shown that biphenyl should be stable for long-term operation at high temperature and non-condensable gas generation will not be a problem. Thus, biphenyl was selected as the working fluid for the battery heat pipes.

PP&C Subsystem Description

The PP&C subsystem is a collective term for the power system control electronics. This system includes items such as shunt regulators, voltage regulators, and battery charge controllers. Their function is to control the flow of energy through the power system to the payload.

Shunt Regulator Description. At the beginning of life of a solar power system the solar array produces excess power. To prevent the rest of the system from being overpowered, a shunt regulator is installed. This regulator shunts off excess current from the array. This energy is dissipated in the form of heat.

Boost Regulator Description. The boost regulator increases the voltage from the batteries up to the nominal bus voltage. There are two basic types of boost regulators. The basic boost regulator handles all of the processed power and the efficiency of the circuit applies to all the power. This regulator places a "buck" inductor and switch in alternate positions such that the opening switch allows the inductor to force the current it had before the switch opened into the load impedance. The output voltage depends on the load impedance and current. The basic booster has a relatively low efficiency and may have loop stability problems.

The add-on booster only processes the boost voltage (usually only 10 volts). The boost power (voltage added times output current) is parallel to the load at the input. Most of the

power is not processed and thus the overall efficiency is much higher than for the basic boost regulator. A failure of the add-on booster results in a lower DC bus voltage, but the system is still functional with degraded performance.

The boost regulator requires monitoring equipment to determine operating parameters and heat sinking to remove waste heat. EMI filters are required to prevent interference from the switching.

Down Regulator Description. The PV array is designed to always provide a higher voltage than the nominal battery voltage. The down or "buck" regulator provides a constant output DC voltage for charging the battery subsystem from the array. The regulator output voltage is always lower than the input voltage. The voltage conversion is accomplished by switching the input on and off. The filter removes the AC component produced by switching, but allows the DC voltage through.

The down regulator is reliable and very efficient (85-90% for nearterm hardware). The efficiency of the regulator depends on the internal operating frequency and the input-output voltage difference. As the frequency goes up the size goes down and so does the efficiency. This regulator does not isolate the input from the output loads. If the regulator is not properly used, then it can cause radio interference since it uses switching to interrupt the current. Proper EMI filters are required to eliminate this interference. Monitoring equipment is required to determine the proper operating conditions. Heat sinking is required to remove waste heat.

TECHNOLOGY ISSUES

Key issues for the PV subsystem are summarized in Table E-1. The key issues for development of a NaS battery subsystem are summarized in Table E-2.

The key issue with sodium sulfur batteries is achieving cycle life to permit operation as a satellite battery. While the specific energy, of the sodium sulfur system, is much higher than the current baseline nickel hydrogen batteries, the cycle life is much lower. Primary failure

PV/NAS BATTERY TECHNOLOGY ROADMAP

mechanisms are related to corrosion of the seals and cell components by the chemically active sulfides and the fragility of the beta alumina electrolyte. Design features have been developed to mitigate the effect of these failure mechanisms so that a failure is not catastrophic. Cracking of the electrolyte or loss of cell case integrity does however, result in loss of the cell however. Continuing cell development is aimed at resolving these issues.

TABLE E-1. PV SUBSYSTEM ISSUES, IMPACTS, AND DEVELOPMENT AREAS

Issues	Impacts	Potential Development Areas
Large array area due to low Martian insolation	<ul style="list-style-type: none"> •Increased life cycle cost (LCC) •Increased deployment time •Increased number of cells with reduced system efficiency and reliability 	<ul style="list-style-type: none"> •Higher efficiency top cell (AlGaAs) •Robotic or automatic deployment system •Thin film arrays •Roll-out arrays
Small cell size	<ul style="list-style-type: none"> •Increased number of cells with reduced system efficiency and reliability 	<ul style="list-style-type: none"> •Higher efficiency top cell (AlGaAs) •Larger size cells
Cell efficiency	<ul style="list-style-type: none"> •Increased array size and LCC 	<ul style="list-style-type: none"> •Higher efficiency top cell (AlGaAs)
Cell cost	<ul style="list-style-type: none"> •Increased LCC 	<ul style="list-style-type: none"> •Low cost production techniques
Deployment system and support structure weight	<ul style="list-style-type: none"> •Increased LCC 	<ul style="list-style-type: none"> •Flexible roll-out array •Robotic deployment
Operating temperature fluctuation and extremes	<ul style="list-style-type: none"> •Reduced cell life due to thermal stress/increased LCC 	<ul style="list-style-type: none"> •Design and test for appropriate environment •Test for thermal extremes
Martian wind	<ul style="list-style-type: none"> •Increased structure mass and LCC 	<ul style="list-style-type: none"> •Lightweight structure and tie-downs
Dust accumulation	<ul style="list-style-type: none"> •Increased array area and LCC •Maintenance cost 	<ul style="list-style-type: none"> •Robotic dust removal system

TABLE E-2. NaS BATTERY SUBSYSTEM ISSUES, IMPACTS, AND DEVELOPMENT AREAS

Issues	Impacts	Potential Development Areas
Cycle life	•Increased life cycle cost	•Physical and chemical stability of alpha alumina seal •Physical and chemical stability of electrolyte •Sealing technology for tubesheet to cell case
High operating temperature	•Heavy heat pipes, poor performance, toxic working fluids (cesium or mercury) or high pressure (water)	•Low mass C/C heat pipe radiator •Heat pipe working fluids (biphenyl)
Safety (explosion, fire, toxic fumes, formation of sulfuric acid)	•Increased manufacturing cost	•Battery casing design

TECHNOLOGY ASSESSMENT

The technology bases were assessed for the following major PV/battery subsystems:

- PV array;
- Batteries;
- Thermal management; and
- PP&C.

The technology readiness of each assembly was evaluated using the NASA technology readiness levels. These evaluations are summarized in Table E-3 which shows that the power system has technology readiness levels ranging from 3 to 5, depending on the particular subsystem. The technology base for subsystems is discussed in the following sections.

TABLE E-3. GaAs-CIS PV/NaS BATTERY TECHNOLOGY ASSESSMENT

Subsystem	Technology Readiness Level	Comments
GaAs/CIS PV cells	5	Pilot development phase for cells; APSA program
NaS batteries	4	Breadboard cells tested by Air Force and prototype battery is under development
Battery thermal management	3	Radiator component development currently underway; biphenyl investigated as heat pipe fluid
PP&C	5	Similar components under development for Space Station Freedom (SSF)

System State-of-the-Art

The GaAs/CIS PV array and NaS battery system has a NASA Level of about 4. The concept of this type of a system has been formulated but the details of the system have not been worked out. Specifically, this includes the integration of the NaS battery storage into the system. Though NaS batteries are a basic secondary type battery they require special thermal control to work. The batteries require an operating temperature of 598 °K. The PP&C subsystem will have to work in conjunction with thermal control system to maintain this temperature. In addition, to overcome the fragility problems of NaS batteries, it has been proposed to launch the batteries in a frozen state (<573 °K). Once on the planetary surface, the batteries will have to be brought up to temperature through some type of external source. For a flight test experiment, the power source will be the Shuttle payload power bus. Another issue is that prior to the time the NaS batteries are brought on line the spacecraft will need power for basic operations such as ground telemetry and array deployment. Some other source of energy, such as a primary battery, will be necessary and will increase the complexity of the PP&C subsystem. In this system the operational characteristics of the NaS battery are the key issues. Due to the low readiness level of the NaS battery and the thermal management subsystem, the overall system readiness level is relatively low compared to current PV/battery systems.

PV Array State-of-the-Art

The current cell technology level is between 5 and 6 on the NASA scale. The Boeing cell development is in the pilot line phase now (Ref. E-12). Production volume is expected by 1996. The GaAs top cell is currently made by Kopin company while the bottom CIS cell is made by Boeing. An advanced cell design (AlGaAs/CIS) could be available well before 2008. Cell testing has progressed through the preliminary qualification stage. Testing has included thermal cycling, UV illumination, off-angle, vacuum stability, and humidity tests. Small coupon panels have been tested for mechanical shock, pyro shock, acoustics, vibration, and

PV/NAS BATTERY TECHNOLOGY ROADMAP

thermal cycling. Current cell size is 2 x 4 cm (1991). Boeing is also working on a thin plastic substrate to replace the current glass substrate.

Array development has been done for both rigid and flexible arrays. Various array technologies are summarized in Table E-4 (Ref. E-5). For large systems, the support structure development maturity is at a NASA Level 7. The only large system now being planned for launch is the Space Station Freedom array. The array support structure was flight tested under the SAFE program. Under the current schedules these designs will reach Level 9 by the year 2000.

TABLE E-4. DESCRIPTION OF VARIOUS ARRAY TECHNOLOGIES AND APPROXIMATE PERFORMANCE FIGURES OF MERIT (IN EARTH ORBIT)

Name	Description	PV CELLS (BOL)	Base Power (EOL kWe)	Life (years)	Area Density (W/m ²)	Specific Power (W/kg)
Rigid Honeycomb (Typical)	Aluminum honeycomb	Si: BSF 8 mil	3.4	7	128.3	32
HUBBLE	Roll-out flexible blanket	Si: 2x4 cm ² BSFR	4.4	2	117	19
Space Station	Flexible Kapton fold-out blanket	Si: wrap through contacts 8x8 cm ²	75	4	90	66
APSA	Flexible Kapton fold-out blanket	Si: 2x4 cm ² BSF 13.8%	3.7	10	95	93
SUPER (Planar)	Flexible fold-out with Beryllium	GaAs/Ge 6x6 cm ² , 18%	5.3	5	121.7	26.5
AHA	Ti honeycomb with 1.4 x concentrating shutters	GaAs/Ge -2 junction, 24%	5	10	95.5	28.8
ESSA	Al honeycomb with protective shields	GaAs/Ge single junction, 18%	5	10	137	23.2

The roll-out type array approach was developed in the early 70's at Wright-Patterson Air Force Base during the Flexible Roll-Up Solar Array (FRUSA) program. The same basic technology is used today for power generation on the Hubble Telescope. Some of the arrays in the flexible fold-out category are the SAFE array, Mil-Star, Space Station and the APSA array

developed by TRW for JPL. The APSA array is designed for GEO orbit. The APSA program has been ongoing for several years and has significantly reduced the mass of arrays using a flexible array design. APSA has a goal of demonstrating a producible array system having a specific power greater than 130 W/kg (BOL) at 10 kW (BOL). A research and development array that should be seen as both "fold" and "roll" out is the inflatable array. The inflatable array approach is funded by DARPA and is being developed and build by L'Garde Inc. The DARPA program is called Inflatable Torus Solar Array Technology (ITSAT) and is scheduled to conduct a space flight experiment in the 4th quarter of 1993. The inflatable array is considered a high risk - high payoff approach.

The current application cell design could utilize either an inflatable array, an APSA type array (with additional support structure), or roll-out array.

Battery Subsystem State-of-the-Art

Development of sodium sulfur batteries was initiated in the 1960s for electric vehicle applications (Ref. E-13). Since then, development has progressed to the point that prototypes and breadboards are now being fabricated or are in test. Advancement of the technology has been limited by the low level of funding and the concern over the safety and operating temperature of the battery. Several manufacturers are engaged in ceramics development on the electrolytes and, in the United States, Hughes and Eagle-Picher are actively engaged in the development of space type batteries (Ref. E-14).

Eagle-Picher, in conjunction with Hughes Aircraft, had an Air Force contract (administered by WPAFB) which ran from 9/86 to 1/91 to develop a NaS cell for Low Earth Orbit (LEO). The major goals of this program were the following:

- specific energy of 397 kJ/kg (50 W-hr/lb);
- 30,000 charge-discharge cycles;
- 2C discharge rate;
- 5 year calendar life; and

- withstand LEO environment.

A Mars surface environment would be much more benign for a battery subsystem than a LEO application due to a reduced charging rate, a reduced number of cycles (only 1825 for 5 years), and a gravity environment (poor distribution of reactants in microgravity environment can cause current blockage due to formation of a non-conductive layer). In addition, the battery can be qualified using only ground testing.

For space applications, NASA Level 4 would apply. That is, breadboard cells have been in test for some time by the Air Force and a prototype of a satellite battery is in development under Air Force contract and is to be demonstrated in 1993 or 1994 (Ref. E-7). Further development is required to accelerate the fabrication and testing of cells and batteries in order to identify currently unknown problem areas. Specifically, testing will include space environmental testing, materials compatibility testing, and cycle testing. Under current funding levels, flight test of the battery is projected for the 1996 to 1997 timeframe. Availability for space applications is projected for the year 2000.

Thermal Management Subsystem State-of-the-Art

NASA LeRC is currently carrying out an integrated multi-element project for the development of space heat rejection subsystems with special emphasis on low mass radiators in support of SEI power system technology (Ref. E-15). This effort involves both in-house and contracted efforts. Contracted efforts involving Rockwell International (RI) and Space Power Incorporated (SPI) are aimed at the development of advanced radiator concepts (ARC). NASA LeRC is also involved in a joint program with DOE to demonstrate a flexible fabric heat pipe radiator concept being developed by Pacific Northwest Laboratories (PNL). In-house work at NASA LeRC is designed to guide and support the overall program by system integration studies, heat pipe testing and analytical code development, radiator surface morphology alteration for emissivity enhancement, and composite materials research focused on the development of low mass, high conductivity fins. This program is concentrating on technologies capable of

development before the end of the decade for both surface power and nuclear electric propulsion (NEP) applications.

Specific objectives of the ARC contracts are to achieve specific mass values $<5 \text{ kg/m}^2$ with radiator surface emissivities of 0.85 or higher at typical radiator operating temperatures, and reliability values of at least 0.99 for the heat rejection subsystem over a ten year life. These figures represent a factor of two improvement over the currently considered heat rejection subsystem for SP-100, and even greater improvement factors for state-of-the-art heat rejection systems used in current spacecraft applications.

Presently, Rocketdyne division of Rockwell International is involved in the development of a carbon-carbon (C-C) or graphite heat pipe radiator panel. Rocketdyne has a NASA contract entitled "SP-100 Advanced Radiator Concepts" which started in 1987 and is part of the CSTI (Civilian Space Technology Initiative) program. This program will be completed in January of 1993. This program involves development of a C-C heat pipe suitable for use in an SP-100 radiator. However, this technology will be suitable for other radiator applications as well including battery power systems (using other working fluids). The hope is that this program will develop generic technology which can be used for all future space radiators because of its reduced mass compared to metal heat pipe radiators. Carbon-carbon is a new structural material which requires different fabrication techniques than for metals or composites. A key objective of this program is to demonstrate the ability to fabricate C-C heat pipes with a thin metal liner, wicks, caps, and fill tube. The brazing technique required to attach liners is the same as would be required to attach manifolds to the heat pipes. Heat pipes filled with potassium will be designed, fabricated, and tested during this program. Thermal cycle testing will be done in a vacuum to demonstrate the integrity of the heat pipes.

Beginning in 1989, small samples of heat pipe panels were fabricated by Rocketdyne as part of the CSTI program. The next phase of the program will involve fabrication and testing of complete heat pipes several feet long.

The working fluids and temperatures for the SP-100 system would be different than for lower temperature battery systems. Thus, Rocketdyne has an on-going IR&D effort which involves development of a C-C heat pipe for lower temperature applications. This effort will eventually include fabrication and testing of a heat pipe. Rocketdyne is also looking at a higher thermal conductivity C-C heat pipe design.

The objective of the joint NASA LeRC/Air Force program with PNL (Light Weight Advanced Ceramic Fiber [ACF] Heat Pipe Radiators) is to demonstrate the feasibility of a low mass ceramic fabric/metal liner heat pipe for a wide range of operating temperatures and working fluids (Ref. E-15). Specifically, the NASA LeRC objectives are to develop this concept for application to space radiators with operating temperatures below 500 °K using water as the working fluid. The specific mass goal for these heat pipes is 3 kg/m² or less at a surface emissivity of greater than 0.85.

Several heat pipes were built for the ACF program using titanium and copper foil material for containment of the water working fluid. A heat pipe with an 0.2 mm Ti liner was demonstrated in early January 1991. An innovative "Uniskan Roller Extrusion" process has also been developed at PNL and used to draw 0.76 mm wall tubing to a 0.05 mm foil liner in one pass. The water heat pipes fabricated for LeRC have been subjected to a test program to evaluate performance and reliability at demanding operating conditions.

Future thrusts of the ACF program will be to perfect the heat pipe fabrication procedure using very thin (0.025 to 0.05 mm) foil liners which are internally texturized by exposure to high pressures (Ref. E-15). Plans will also be developed to perform hyper-velocity and ballistic velocity impact tests in order to determine if secondary fragments from a penetrated heat pipe will result in failures of neighboring heat pipes. Another major challenge will be to design a heat pipe with high conductivity, low mass fins as a first step toward the fabrication of low mass radiator panels.

The NASA LeRC in-house materials program includes radiator surface morphology

alteration by arc texturing for emissivity enhancement purposes (Ref. E-15). Emissivity enhancement has been demonstrated for graphite-copper samples.

PP&C State-of-the-Art

Assigning a NASA Readiness Level to PP&C is difficult. There are many systems that have flown which would make parts of the PP&C subsystem Level 9, but each PP&C system was custom design for each spacecraft design. Only until recently has the array and battery PP&C become standardized into packaged systems. In the Space Station Freedom program, standard PP&C components are undergoing qualification. Recent military programs have ended with qualified packaged PP&C component designs.

The PP&C system design is based on a reasonable electronics component evolution, and there are no significant technology issues associated with its development. It will be necessary to fabricate breadboard hardware for testing and evaluation purposes, but there is no need to initiate any advanced component development. Most of the hardware elements have been or shortly will be operating in a relevant environment on other spacecraft or the SSF electrical power subsystem.

DEVELOPMENT PLANS

The development program was divided into seven major tasks. The first four tasks are component development tasks. The last three tasks includes the system design, fabrication, integration, and testing for the Ground Engineering System (GES), Qualification Unit (QU), and Flight Unit (FU).

Testing will be done on the component, subsystem, and system level (qualification testing). The system level tests will show any possible negative interactions between subsystems.

The PV/battery development tasks are described in the following sections. Each task will include a section on objectives and the statement of work.

Task 1. PV Array Development

Objectives: Complete development of high efficiency tandem cell, a low mass flexible array, and an automatic or robotic deployment approach.

Statement of Work: The following subtasks are identified:

Task 1.1 Subscale PV Array Development. Complete development of GaAs/CIS or advanced (AlGaAs/CIS) tandem cell. Develop a larger cell size. Test subscale PV panels to verify performance under appropriate environmental conditions (thermal cycling, vibration tests, strength and stiffness, radiation, etc.). Develop the array structure and deployment concept.

Task 1.2 Full Scale PV Array Development. Develop and test full scale PV arrays. Verify adequate performance.

Task 2. Battery Subsystem Development

Objectives: Develop a full scale flight weight battery module which can be integrated into a PV/battery power system. Demonstrate materials compatibility, safety, and performance margins.

Statement of Work: This effort was divided into the following subtasks:

Subtask 2.1 Preliminary Battery Development. Demonstrate the feasibility of the selected battery design for planetary surface applications. Test a prototype battery to demonstrate materials compatibility, safety, and component life.

Subtask 2.2 Final Battery Module Design. Design a full scale flight weight battery module.

Subtask 2.3 Battery Module Fabrication, Assembly, and Testing. Build and test (performance, mechanical, and thermal cycling) the battery module. After initial breadboard validation testing is complete, perform additional module testing in a relevant environment.

Task 3. Thermal Management Subsystem Development

Objectives: Develop and demonstrate a low mass, reliable heat pipe radiator which will operate at about 600 °K. Develop and demonstrate components for thermally isolating the battery from the rest of the system and the environment. Develop a thermal management approach for the PP&C components.

Statement of Work: This effort was divided into the following subtasks:

Subtask 3.1 Heat Pipe Demonstration. Fabricate and test representative length heat pipes to fully characterize heat pipe performance. Compare test results with predicted performance over the anticipated range of operating conditions including startup, shutdown, and restart.

Perform limited life testing of the heat pipes. Identify deterioration mechanisms, measure deterioration rates, and assess the adequacy of assembly and cleaning procedures. Withdraw heat pipe samples sequentially throughout the test period. Drain, section, and analyze the samples for corrosion, carbon diffusion, braze stability, and any other signs of deterioration.

In conjunction with the heat pipe performance and life testing, develop and demonstrate techniques for nondestructive examination (NDE) of the heat pipe elements and assembly. Assess the adequacy of liner bonding and weld joints. Determine if the correct fit-ups and interfaces were obtained in the assembled piece.

Subtask 3.2 Radiator Enhancement. Increase the applicability of the radiator concept by performing various enhancement tasks. Examine survivability options and extended length heat pipes.

Perform analytical assessment, testing, and enhancement design development to insure long life for Mars missions. Consider natural threats such as micrometeoroids and dust erosion.

Fabricate a long heat pipe. Develop alternate techniques for fitting the liner into the tube. Investigate alternative tube fabrication, liner fabrication, and coating processes.

Subtask 3.3 Heat Pipe Integration and Testing. Develop and demonstrate techniques for attaching the heat pipes to the battery assembly. Subsequently, demonstrate heat pipe integration into a representative radiator section. Test the radiator section to provide an accurate overall heat transfer coefficient. Verify radiator dynamics and performance. Test the assembled unit in a cold wall, vacuum chamber, simulated space environment. Validate temperature drop predictions and assess component interactions.

Subtask 3.4 Thermal Management Subsystem Design, Assembly, Fabrication, and Testing. Develop the detailed design of the thermal management subsystem. Resolve specific design issues such as the effects of differential thermal expansion, deployment features, monitoring instrumentation and control equipment, local insulation, and trace heating of the battery for thawing.

Design, fabricate, and test a representative full scale thermal management subsystem. Complete performance, mechanical (stress, shock, and vibration), thermal cycling tests.

Task 4. PP&C Subsystem Development

Objectives: Demonstrate adequate steady state and transient performance, life, and immunity to the environment (including launch and operating). Demonstrate the software capability to handle power system nominal operation and failure modes.

Statement of Work: This effort was divided into the following subtasks:

Subtask 4.1 Electrical Components. Build breadboard units to demonstrate and check functional performance of the individual component circuit designs. Incorporate any necessary design modifications and improvements into brassboard units. Verify functional performance within the constraints of the actual component configuration. Fabricate prototype units and perform a series of tests using simulated input and output loads. Test the controller to validate the operating system software. Include the following testing:

- start up, steady state and transient control;
- failure simulation and detection and switching;

- effects of temperature extremes and thermal shock;
- effects of environment;
- shock and vibration;
- cold plate heat loads; and
- EMI generation and susceptibility.

Subtask 4.2 Software - Check out the controller software using simulated inputs and outputs.

Task 5. Ground Engineering System (GES) Testing

Objectives: Design a system concept which will meet Mars power system applications. Show the concept feasibility. Verify adequate performance and life for an integrated system.

Statement of Work: This effort was divided into the following subtasks:

Task 5.1 GES Design. Identify and characterize specific power system applications. Determine power system requirements. Define optimum power system module size based on trade studies which minimize the overall life cycle cost of the power system for all applications (trade between development cost and mass).

Identify concepts and perform tradeoff studies (performance, reliability, risk, safety, and life cycle cost) to select the optimum system design. Complete feasibility studies for the selected concept. Definitize the remaining hardware development tasks based on the system concept chosen.

Design a complete power system to at least meet the minimum life requirement (10 years for arrays and 5 years for batteries). Perform both design point and transient analyses to verify the design. Perform this task in parallel with the component development tasks to insure proper system characteristics

Task 5.2 GES Performance Tests. Manufacture the GES components and assemble.

Pressure and leak check the assembly, fill the batteries and heat pipes, complete a electrical check-out, and check out all active devices to the extent possible.

Design the test program for the GES to verify all performance characteristics of the unit in conjunction with subjecting the GES to acceptance level tests. Conduct performance and thermal vacuum tests during a single thermal vacuum test sequence to demonstrate technical capabilities while minimizing program cost. Complete the following performance testing activities:

- checkout and refine subsystem assembly procedures;
- verify operation of ground support equipment (GSE) and interfaces with the GES;
- verify start up capability;
- verify steady state performance characteristics;
- establish effective operating range of the system;
- check out software and verify autonomy (include all operational modes and simulate failure modes);
- simulate normal switchover from one module to another;
- simulate failures to trigger module switchover; and
- establish system sensitivity to off-normal conditions such as: (1) partial loss of radiator cooling, (2) varying radiator heat removal profile, (3) partial loss of electronic cooling, and (4) temporary losses of heat sink with varying duration.

Task 5.3 GES Life Test. Refurbish the GES after completion of performance,

acceptance, and margin tests. Refurbishment will include the following:

- replacing or repairing components as necessary to ensure that the GES is returned to its as-built condition;
- addition of special instrumentation required for the life test phase; and
- modification of the main radiator heat removal system or replacement of the main radiator with a dump heat exchanger.

Install instrumentation to provide a comprehensive diagnosis of the "health" of the GES and to monitor for degradation of major assemblies and individual components. Place the GES on a

multiyear life test in air. Operate the GES at its nominal operating point, with expected GES variations in power output and environment.

Disassemble the GES for diagnosis at the end of the life test. Determine areas to be examined by an analysis of the health monitoring data and from the reliability analysis predictions.

Task 6. Qualification Program Testing

Objectives: Fabricate the qualification units (QUs). Verify adequate performance and life for the QUs.

Statement of Work: Develop a comprehensive performance and dynamic testing program which will provide a formal demonstration that the power system will perform as designed after being subjected to simulated launch conditions. Select launch environmental conditions which envelope the probable intensities developed by various launch scenarios.

Begin the qualification effort (a typical approach is shown in Figure E-5) by qualifying the assemblies. Fabricate and assemble the qualified production items into the QU. Qualify the QU by the rules for space vehicle qualification.

PV/NAS BATTERY TECHNOLOGY ROADMAP

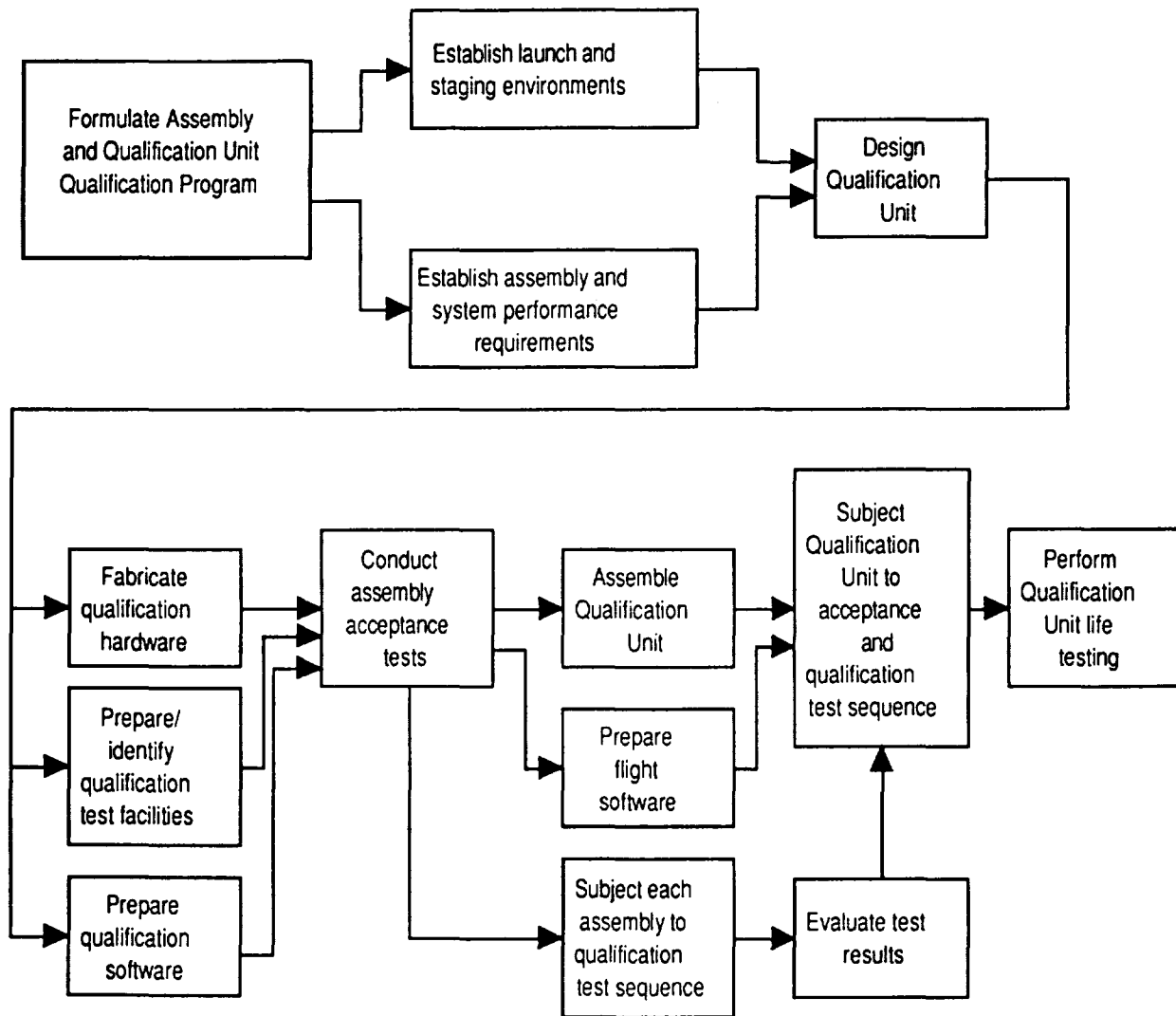

Figure E-5. PV/battery power system qualification program.

This effort was divided into the following subtasks:

Subtask 6.1 Qualification Performance Testing. Conduct performance testing at each level to verify that each item performs as designed. Perform dynamic testing to verify the capability of the power system to withstand launch loads, including acoustic, pyroshock and vibrational. A possible performance and dynamic qualification test sequence for components and assemblies is shown in the matrix of Figure E-6. The corresponding qualification test sequence for the QU is shown in Figure E-7.

Subtask 6.2 Qualification Life Testing (Optional). After completion of the qualification performance testing, partially disassemble the QU and examine the unit. Refurbish the QU as required and modify for endurance testing in air, as described for the GES. Life test the QU.

Component or Subassembly	Functional (1)	Leak	Pyroshock	Functional (2)	Random Vibration	Functional (1)	Leak	Acceleration	Functional (1)	Thermal Cycling	Functional (2)	Thermal Vacuum	Functional (2)	Pressure	Leak	EMC	Life	Functional (1)
Battery Module	X	X			X	X	X			X	X	X	X	X	X	X	X	X
Radiators	X	X			X	X	X			X	X	X	X	X	X		X	X
PP&C	X		X	X	X	X				X	X	X	X			X	X	X
Structure	X		X	X	X	X		X	X	X	X						X	X
PV Array	X		X	X	X	X				X	X	X	X			X	X	X

Figure E-6. PV/battery power system assembly qualification test matrix.

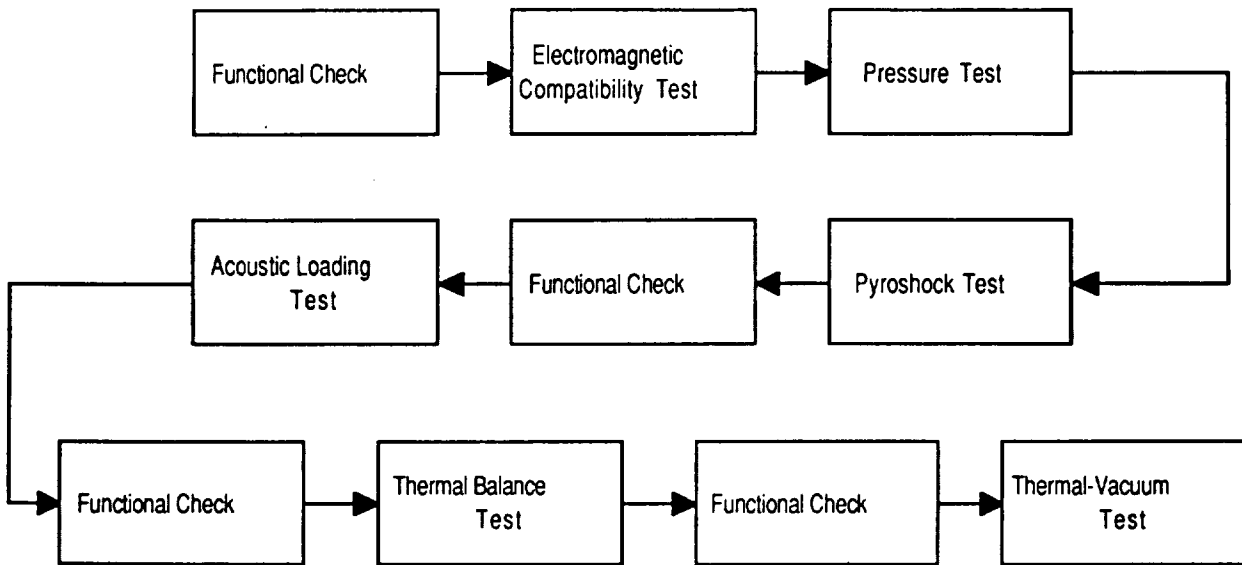

Figure E-7. PV/battery power system QU test sequence.

Task 7 Flight Unit (FU) System Program

Objectives: Fabricate the flight systems and acceptance test the FUs to demonstrate required performance. Deliver the flight systems and provide integration support for the FU with the payload and the launch vehicle.

Statement of Work: Fabricate, acceptance test, and assemble parts to produce the flight systems. Subject the systems to acceptance testing before shipment to the launch site. Use the same test facilities (vacuum chamber, vibration, acoustic) that were used for the qualification program for flight system acceptance testing. Finally, provide launch support activities to insure that the FU meets its design and performance goals associated with integrated payload and launch systems.

The work is divided into the following subtasks:

Subtask 7.1 Flight Component Fabrication. Design, fabricate, inspect, and assemble the components and subassemblies required for the FUs, including all spare parts as required to support the flight system activities.

Subtask 7.2 FU Assembly, Test, and Payload Integration. Assemble and inspect the FUs. Acceptance test the FUs and ship to the launch site. Provide technical support for FU integration with the payload, launch vehicle, and launch support facilities.

Subtask 7.3 FU Launch Support. Provide FU launch support activities to insure that the FU meets its design and performance goals associated with the integrated payload and launch systems.

DEVELOPMENT SCHEDULE

The program starts with a conceptual design task followed by preliminary design and concurrent component development or production of the PV array, battery, thermal management, and PP&C. The detailed design is subsequently completed by the middle of the third year.

Fabrication of components for ground testing for the Ground Engineering System (GES) starts with procurement of long lead materials and equipment in the first part of the fourth year. This leads to assembly of the system by the end of the fifth year.

The GES will be similar to a flight system but will have features such as additional instrumentation and readily removable components to expedite gathering of engineering data and to permit modification of components. It will be tested in a vacuum chamber under normal and off-normal design conditions. After this phase of testing, it will be partially disassembled, examined, refurbished as necessary, and put on life test, nominally for 1 year.

The qualification phase includes design, fabrication, assembly, and qualification testing of individual components, and a complete system. The design effort will be minimal since it would involve only minor modifications to the GES design.

The flight phase of the program includes fabrication, assembly, and acceptance testing of the flight units.

The estimated development and production schedule for the power system is shown in Figure E-8. A minimum development time is about 8 years.

PV/NaS BATTERY TECHNOLOGY ROADMAP

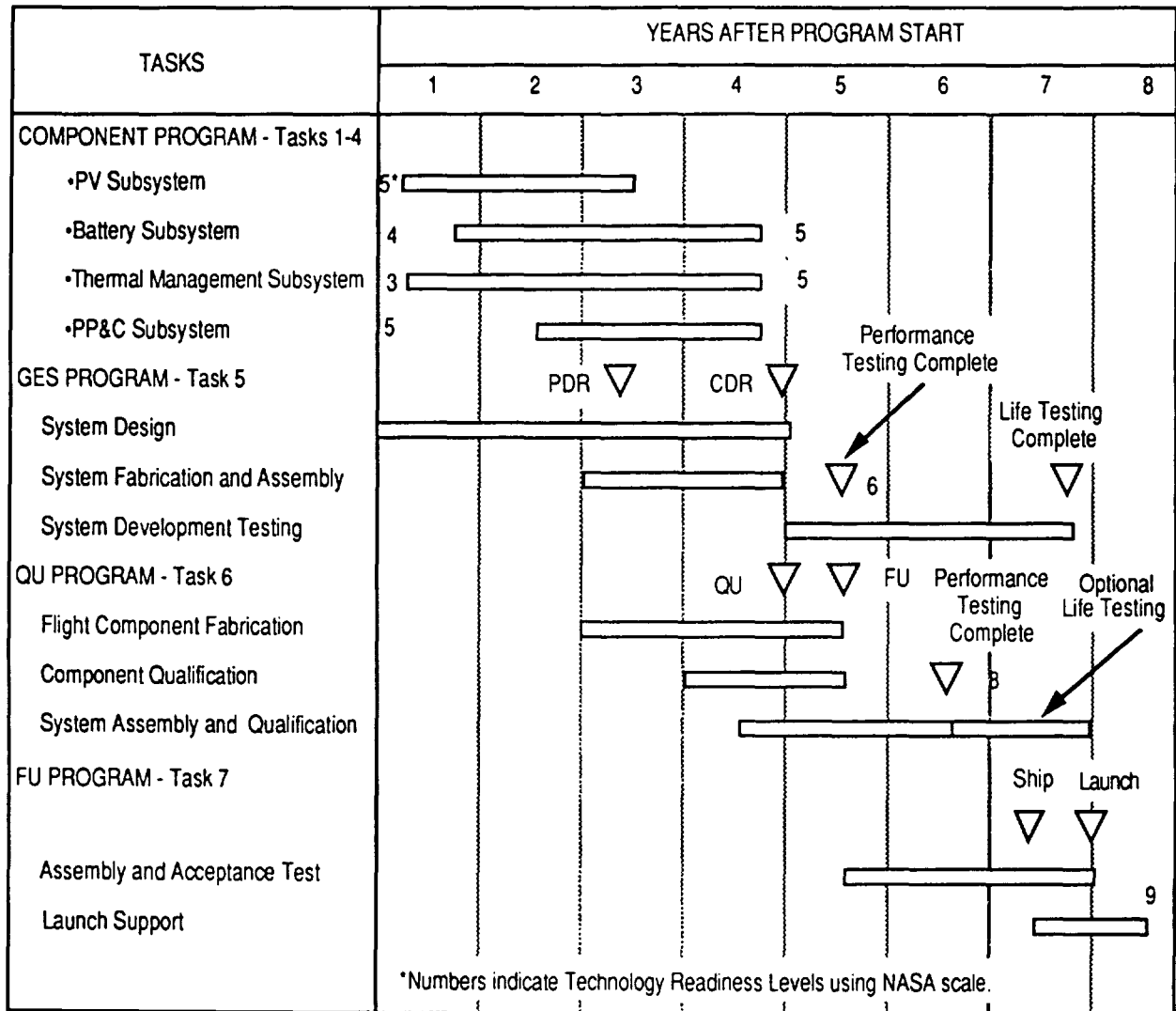

Figure E-8. GaAs-CIS PV array/NaS battery power system development schedule.

REFERENCES

1. Kim, N.P.; and Devaney, N.E.: Low Cost CuInSe₂ Based Solar Cells for Space Application. 26th IECEC Proceedings, Volume 2, August 1991, pp. 314-320.
2. Kim, N.P.; et. al: High Specific Power (AlGaAs)GaAs/CuInSe₂ Tandem Junction Solar Cells for Space Application. 24th IECEC Proceedings, Volume 2, August 1989, pp. 779-783.
3. Stanbery, B.J.; et. al: Thin Film GaAs/CuInSe₂ Solar Cells for Space Power Application. 19th IECEC Proceedings, August 1987, pp. 280-284.
4. Landis, G.A.: Review of Thin Film Solar Cell Technology and Applications for Ultra-Light Spacecraft Solar Arrays. Proceedings of the 10th Space Photovoltaic Research and Technology (SPRAT) Conference, 1989, pp. 180-197.
5. Cooley, Lt. W.T.: Air Force Photovoltaic Array Alternatives. 26th IECEC Proceedings, Volume 2, August 1991, pp. 275-280.
6. Stella, P.M.; and Kurland, R.M.: Development of the Advanced Photovoltaic Solar Array. 26th IECEC Proceedings, Volume 2, August 1991, pp. 269-274.
7. High Energy Density Rechargeable Battery, Preliminary Design Review. Hughes Aircraft Company briefing, 27 April 1988.
8. Petri, D.A.; Cataldo, R.L.; and Bozek, J.M.: Power System Requirements and Definition for Lunar and Mars Outputs. 25th IECEC proceedings, Vol. 1, August 1990, p. 18.
9. Withrow, C.A.; et al: SEI Rover Solar-Electrochemical Power System Options. 26th IECEC, August 1991, p. 319.
10. Marcoux, L.; and Allen, D.M.: Conceptual Design of a Large Spacecraft Power System Utilizing a Sodium-Sulfur Battery. IECEC'83, Vol. 4, August 1983, p. 1470.
11. Grzyll, L.R.: Investigation of Heat Pipe Working Fluids for Thermal Control of the Sodium/Sulfur Battery. 26th IECEC proceedings, Vol. 3, p.1390.
12. Kim, N.P.: Personal Communications. Boeing Defense and Space Group, Seattle, WA, 10 September 1991 and 3 October 1991.
13. Linden, D.: Handbook of Batteries and Fuel Cells. McGraw Hill Book Company, 1984.
14. Taenaka, R.: Personal Communications. Hughes Aircraft Co., 19 February 1992.
15. Juhasz, A.J.: An Overview of the LeRC CSTI Thermal Management Program. Paper no. AIAA-91-3528, AIAA/NASA/OAI Conference on Advanced SEI Technologies, September 4-6, 1991.

APPENDIX F

INTRODUCTION

Space Nuclear Reactor Power Systems (SNRPS) are primarily suitable for application to satellites with high power requirements and fixed base high power planetary surface applications and electric propulsion applications. Currently envisioned Mars surface power systems include power levels of 25 and 75 kWe.

Thermionic reactor systems use a passive power conversion approach to generate electricity. Typical thermionic power conversion systems include STAR-C (out-of-core TI, conduction cooled UC₂/graphite core), Driver Fuel In-Core Thermionic Fuel Element (TFE), and the In-Core TFE Heat Pipe Cooled Reactor (Refs. F-1 through F-10).

The thermionic fuel element (TFE) based power systems have the potential to be designed for use at sufficiently low temperatures such that the reactor structure and containment can be fabricated entirely from stainless steel. Thus, a thermionic system would not need special protection from the Martian environment as would a higher temperature system using refractory metals.

CONCEPT DESCRIPTION

Based on its superior mass characteristics, scalability aspects, and the possibility that it can be operated at a sufficiently low temperature to permit the use of an all stainless steel external structure the Driver Fuel In-core TFE system was selected as the most likely candidate for a thermionic planetary surface based power system of less than 100 kWe output.

The Driver Fuel In-core TFE concept couples in-core TFEs with UO₂ driver fuel pins (where required) for criticality purposes. A pumped liquid metal heat transport loop removes waste heat from the reactor core. The waste heat is rejected to space by a heat pipe radiator. Rotating radial reflector drums are used for both control and primary reactor shutdown. In-core safety rods provide the backup shutdown function. The driver fuel is fully enriched.

Figure F-1 illustrates the key features of the fast driver fuel in-core TFE system concept, which is based on existing or presently emerging technology. The system is easily scalable over the range of 10 to 100 kWe. The system contains an in-core thermionic reactor coupled to a fixed radiator by a single pumped, liquid metal cooling loop. NaK at a maximum temperature of 970 °K is circulated through the core by one of two redundant EM pumps similar in design to those developed for SNAP 8. A TEM pump similar to the one used in SNAP 10A provides passive decay heat removal. A sodium heat pipe radiator was designed to reject waste heat to space. A redundant power processing and control (PP&C) system, based on a 5 year extrapolation of Space Station Freedom technology, completes the major subsystems in the concept.

The TFE design, also shown in Figure F-1, is based on the UO₂ fueled F-series thermionic converter. The fast neutron spectrum of this fuel provides scalability to higher power levels where no drivers are needed.

The ability to use the same basic reactor concept over a full range of power outputs reduces the amount of development required and the amount of qualification testing required. In the case of the fast driver concept scaling is accomplished by using the same TFE and driver pin design and adjusting their quantities within the reactor vessel to meet the required power output.

THERMIONIC REACTOR POWER SYSTEM TECHNOLOGY ROADMAP

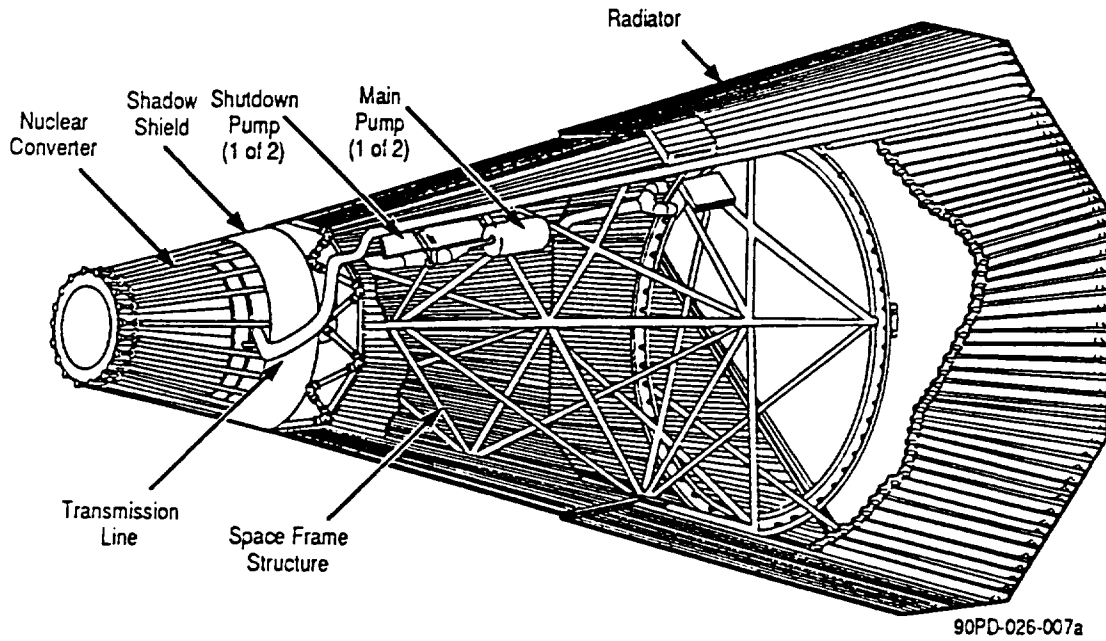

40 kWe Baseline Power System

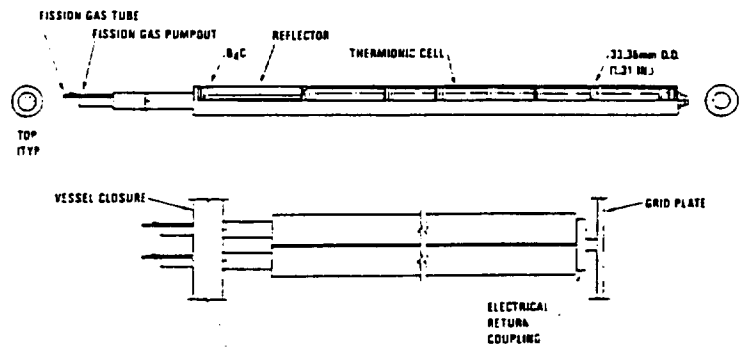
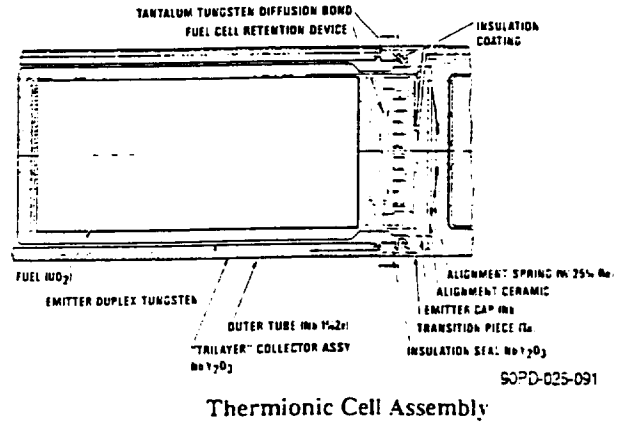
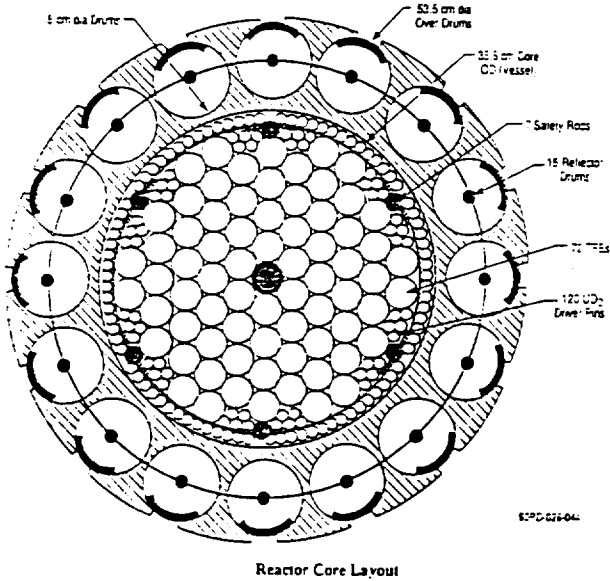

Figure F-1. Driver Fuel In-Core TFE system concept.

TECHNOLOGY ISSUES

The key issues are summarized in Table F-1.

TABLE F-1. SUMMARY OF KEY ISSUES, IMPACTS AND DEVELOPMENT AREAS

Issues	Impacts	Potential Development Areas
High development cost due to safety assurance program	•Increased life cycle cost	•Flight demonstration program
Safety of nuclear systems during operation	•Increase in system mass for shielding - may be especially significant if in-situ materials are not used	•Use of in-situ materials for shielding
Safety of nuclear systems during launch	•Public pressure may prevent system from being launched and mission from not being completed	•PV/RFC power system •SD power system
TFE lifetime and performance	•Lower emitter temperatures if lifetime cannot be met and higher system mass	•In-reactor TFE and cell tests (TFE Verification Program) •High strength emitter materials
C-C heat pipe Fabricability	•Higher system mass if must use all-metal heat pipes	•C-C metal lined heat pipe development
Radiation hardenability of electronic components	•Heavier shielding mass required if components cannot be hardened	•Under development for AF programs

TECHNOLOGY ASSESSMENT

The technology bases (Refs. F-1 through F-7) were assessed for the following major Fuel Driver In-Core TFE assemblies:

- thermionic power reactor;
- thermionic fuel elements;
- heat rejection subsystem; and
- PP&C subsystem.

The technology readiness of each assembly was evaluated using the NASA technology readiness levels. These evaluations are summarized in Table F-2 which shows that Fuel Driver In-Core TFE assemblies have technology readiness levels ranging from 3 to 5. The technology base for each assembly is briefly discussed in the following sections.

TABLE F-2. IN-CORE TI TECHNOLOGY ASSESSMENT

Assembly	Technology Readiness Level	Comments
Reactor	3	No reactor assemblies built; new military programs due soon; EM pumps under development for SP-100; stainless steel reactor built for SNAP 10 program
TFE	4	Extensive data base from earlier testing; long term tests nearly complete
Heat Rejection Subsystem	4 / 3 *	Currently under development
Electrical	4	Radiation hardened components

*Metal heat pipe/carbon-carbon heat pipe.

Thermionic Power Reactor State-of-the-Art

The driver fuel TFE reactor has been designed for safety from the ground up and requires no technology changes over the complete power range from 10 to 100 kWe. The reactor uses the F series thermionic converter, which has a significant data base from earlier thermionic programs and permits the reactor to scale from 10 kWe to well beyond the 100 kWe level. The UO₂ fuel in the TFE and driver pins has a broad technology base from the Liquid Metal Fuel Breeder Reactor (LMFBR) program and previous TFE test programs (Refs F-6 and F-7).

It is possible to design this reactor to use stainless steel for its containment shell and piping, thus obviating the need to expose any refractory materials to a planetary atmosphere such as on Mars. SP-100 control rod and sliding reflector segment control assemblies are undergoing laboratory testing. These would be used in the design to minimize development costs.

Several basic EM pump design concepts have evolved through the years. Only two designs are inherently low in weight, the ALIP and the thermoelectric electromagnetic (TEM) pump. A TEM pump is being developed for the SP-100 program to-pump molten lithium at higher temperature than this application.

A very substantial liquid metal handling data base exists at the Energy Technology Engineering Center (ETEC), operated by Rocketdyne for the Department of Energy, which was

responsible for liquid metal testing of many of the component destined for use in the Clinch River Breeder Reactor. This included operation of numerous EM pumps.

An extensive data base exists for the TFE elements of the driver fuel TFE reactor, however, a full-up assembly of such elements in a critical assembly has not been built. This results in a NASA technology readiness rating of 3.0 for this subsystem, which is the same as that of the SP-100 power reactor.

Thermionic Power Conversion Unit (PCU) State-of-the-Art

The thermionic power conversion device is a static converter, requiring no moving parts. Device efficiency is about double that of thermoelectrics. The TFE is the key technology item in the fast driver fuel TFE design concept. The important technology areas include thermionic converter performance, cesium vapor management, emitter lifetime and electrical insulator stability in the 1000 °K temperature regime and fast flux reactor environment.

The F-series converter is particularly suited to this application because it offers the scalability not available with other thermionic conversion devices. Due to this scalability, critical technology and experience developed at the lower power applications will be valid for the higher power versions.

A TFE verification program, currently in progress, builds directly on an extensive data base developed in the 1960s and early 1970s in an AEC/NASA program. In this program, TFEs were developed and tested and the processes necessary to fabricate long lived components were developed. Thermionic converters were operated for more than 40,000 hrs out-of-pile and a TFE lifetime of 12,000 hrs was demonstrated in-pile.

Fueled emitters were put under test in January 1985 in the TRIGA reactor at General Atomics (GA) during the SP-100 program, to study emitter distortion. As of June 1989, about 35,000 hours of real time testing had been attained. In addition, insulators and intercalated cesium graphite reservoirs are under test and the preliminary results have shown good stability and performance.

The entire TFE verification program, which will include in-pile testing of complete 6 cell TFEs is scheduled for completion in CY 1994 and is currently on track. These factors lead to a NASA technology readiness rating of 4.0.

Heat Rejection Subsystem (HRS) State-of-the-Art

Presently, Rocketdyne division of Rockwell International is involved in the development of a carbon-carbon (C-C) or graphite heat pipe radiator panel. Rocketdyne has a NASA contract entitled "SP-100 Advanced Radiator Concepts" which started in 1987 and is part of the CSTI (Civilian Space Technology Initiative) program. This program will be completed in January of 1993. This program involves development of a C-C heat pipe suitable for use in an SP-100 radiator. However, this technology will be suitable for other radiator applications as well including TFE power systems. The hope is that this program will develop generic technology which can be used for all future space radiators because of its reduced mass compared to metal heat pipe radiators. Carbon-carbon is a new structural material which requires different fabrication techniques than for metals or composites. A key objective of this program is to demonstrate the ability to fabricate C-C heat pipes with a thin metal liner, wicks, caps, and fill tube. The brazing technique required to attach liners is the same as would be required to attach manifolds to the heat pipes. Heat pipes filled with potassium will be designed, fabricated, and tested during this program. Thermal cycle testing will be done in a vacuum to demonstrate the integrity of the heat pipes.

Beginning in 1989, small samples of heat pipe panels were fabricated by Rocketdyne as part of the CSTI program. The next phase of the program will involve fabrication and testing of complete heat pipes. A planned 3.5 year follow-on to this program could involve the development of a full scale C-C heat pipe radiator panel complete with manifolds and interface heat exchanger. This effort would be generic in scope and thus not include flight qualification. It is not clear whether this follow-on would be part of the CSTI program or part of the SP-100 program.

The current technology level of the radiator subsystem is estimated to be about 4 for the metal heat pipe radiators and about 3 for carbon-carbon heat pipe radiators.

Power Processing and Controls State-of-the-Art

The electronic component technology required for thermionic power processing equipment is being developed for future nuclear space power system applications under the SP-100 program. Currently available analytical and design technologies will be used along with radiation testing. Radiation hardened high reliability Class S parts coupled with component redundancy, where necessary, will ensure a reliable and low risk power processing and control system. Rockwell is currently developing the Space Station Power Management and Distribution System; some of that technology is directly transferable to large thermionic power systems. The use of multiple buses, components for the switching of loads, and switching of subassemblies within the power assembly are technologies common to the two programs.

The required technology for the control and data acquisition functions currently exists, and the technology for autonomous control is under active development for Space Station Freedom (SSF), ESSA and other space power programs. The need for radiation hardened components with these capabilities remains to be demonstrated which results in a technology rating of 4 for this subsystem.

MAJOR DEVELOPMENT TASKS

The technology level of the driver fuel in-core reactor power system components range from 3 to 5, and therefore development testing is required. The testing currently envisioned is briefly described in the following sections. Four component development tasks (reactor, power conversion subsystem, HRS, and PP&C) and three system development tasks (Ground Engineering System, Qualification Unit, and Flight System) are described.

Task 1. Thermionic Power Reactor Development

Objectives: Complete development and testing of the reactor components so that the final reactor design can proceed with a high degree of confidence and the ground engineering and flight test programs can be completed on schedule.

Statement of Work: Develop a fast driver thermionic reactor power subsystem conceptual design. Develop and test components that support the reactor subsystem preliminary design. These components would include such items as control rod drivers, reflectors, drum drives, core assembly, bearings, heat exchangers, EM pumps and expansion compensators.

Task 2. Thermionic PCS Development

Objectives: Complete development of the thermionic fuel element design which will meet the desired performance and life requirements.

Statement of Work: The components for these devices are currently in an advanced state of development. The assembly and test of prototype TFEs in a reactor environment. This would require that the devices currently under test at GA be modified to the exact specification required for the fast driver fuel TFE device and be tested in a nuclear reactor similar to the TRIGA reactor.

Task 3. HRS Development

Objectives: Development and demonstration of a small scale radiator panel. Development of full scale heat pipe radiator and interface heat exchanger.

Statement of Work: The following subtasks are identified:

Subtask 3.1 Heat Pipe Demonstration - Various development efforts are required to bring heat pipe technology to a space qualifiable level. Specific efforts include performance testing, life testing, and nondestructive evaluation.

For performance testing, representative length heat pipes will be fabricated and tested to fully characterize the heat pipe performance. Test results will be compared with predicted

performance over the anticipated range of operating conditions including startup, shutdown, and restart.

Limited life testing will be performed. These tests will identify deterioration mechanisms, measure deterioration rates, and assess the adequacy of assembly and cleaning procedures. Samples will be withdrawn sequentially throughout the test period, drained, sectioned, and analyzed for corrosion, carbon diffusion, braze stability, and any other signs of deterioration.

In conjunction with the performance and life testing tasks, techniques for nondestructive examination (NDE) of the heat pipe elements and assembly will be developed and demonstrated. This effort will assess the adequacy of liner bonding and weld joints. It will also be determined if the correct fit-ups and interfaces were obtained in the assembled piece.

Subtask 3.2 Radiator Enhancement - To increase the applicability of the radiator concept, various enhancement tasks will be performed. These tasks include survivability options and extended length heat pipes.

Analytical assessment, testing, and enhancement design will be done to insure long life for both lunar and Mars missions. Natural threats to be considered include micrometeoroids and dust erosion (Mars).

Significant radiator performance improvements can be achieved with the use of longer heat pipes in some applications. A long heat pipe will be fabricated. Alternate techniques will be developed for fitting the liner into the tube will be developed. Alternative tube fabrication, liner fabrication, and coating processes will also be investigated.

Subtask 3.3 Heat Pipe Integration and Testing - The first step in this task is to develop and demonstrate techniques for thermal and mechanical bonding of the heat pipe to the radiator manifold. Subsequently, heat pipe integration into a representative radiator section will be demonstrated. Testing of the radiator section will be done to provide an accurate overall heat

transfer coefficient. System dynamics and performance will also be verified. The demonstrator will include a surrogate manifold section and a limited number of heat pipes. The assembled unit will be tested in a cold wall, vacuum chamber, simulated space environment. The purposes of this series of tests will be to validate temperature drop predictions, verify manifold design, and assess component interactions.

Subtask 3.4 HRS Design, Assembly, Fabrication, and Testing - This task will provide a focus for the other radiator development tasks. This task will involve the detailed design of a radiator subsystem. Specific design issues will be resolved including the effects of differential thermal expansion, deployment features, monitoring instrumentation and control equipment, local insulation, and trace heating of the manifold and piping

A representative full scale heat pipe radiator and interface heat exchanger will be designed, fabricated, and tested. Testing will include performance, mechanical (stress, shock, and vibration), thermal cycling, and life tests.

Task 4. PP&C Development

Objectives: Complete electronic component development. Verify adequate performance and life.

Statement of Work: Breadboard units will be built to demonstrate and check functional performance of the individual component circuit designs. Design modifications and improvements will be incorporated into brassboard units, which will be used to verify functional performance within the constraints of the actual component configuration. Prototype units will be fabricated and a series of performance tests run using simulated input and output loads. Controller tests will include validation of operating system software. Tests will include:

- Start up, steady state and transient control;
- failure simulation, failure detection, and switching to a backup circuit;
- effects of temperature extremes and thermal shock;
- shock and vibration;

- cold plate heat loads; and
- EMI generation and susceptibility.

Prototype cable harnesses and a prototype parasitic load radiator will be checked out with the electrical components during the system test.

Software will be checked out in conjunction with tests of the controller, using simulated inputs and outputs. Integration and checkout of the software will be performed as part of the system test.

Task 5. Ground Engineering System (GES) Testing

Objectives: Complete the ground engineering system design. Verify all performance characteristics of the unit in conjunction with subjecting the GES to MIL-STD-1540 acceptance level tests. Verify adequate system life. Take the system technology to level 6 (system validation model demonstrated in a simulated environment).

Statement of Work: As a cost reduction measure it has been proposed that GES testing be dispensed with and that space reactor power programs proceed to the flight qualification phase after the component development needed to support final design has been completed. Acceptance of this approach by the technical community is not certain as of this writing, therefore, a discussion of GES testing is included as part of the overall development of a space reactor power system.

After assembly, the GES will be pressure and leak checked, a complete electrical check-out will be performed, and all active devices will be checked out.

Performance and thermal vacuum tests will be conducted during a single thermal vacuum test sequence to demonstrate technical capabilities while minimizing program cost. The performance evaluation will consist of the following major activities:

- checkout and refine subsystem assembly procedures;
- check out procedures for loading NaK into the system;
- verify operation of ground support equipment (GSE) and interfaces between GSE and the GES;

- check out ground cooling systems;
- verify start up capability;
- verify steady state performance characteristics;
- establish effective operating range of the system;
- check out software and verify autonomy (include all operational modes and simulate failure modes);
- establish system sensitivity to off-normal conditions such as: (1)partial loss of radiator cooling, (2)varying radiator heat removal profile, (3)partial loss of electronic radiator cooling, and (4)temporary losses of heat sink with varying duration; and
- determine magnitude of effects on spacecraft for: (1)jitter and vibration, (2)EMI/EMC, (3)thermal radiation to spacecraft, and (4)maneuvering loads.

The MIL-STD-1540 test sequence will integrate acceptance level and design margin tests as appropriate up to qualification levels, to provide a technically sound, minimum cost approach.

When the performance, acceptance, and margin tests are complete, the GES will be placed on a multiyear life test. Instrumentation will be used to monitor for degradation of major assemblies and individual components. The GES will be operated at its nominal operating point, with expected GES variations in power output and environment.

The GES will be disassembled for examination at the end of the life test. Specific areas to be examined will be determined by an analysis of the health monitoring data and from the reliability analysis predictions.

Task 6. Qualification Program

Objectives: A comprehensive performance and dynamic testing program for assemblies and the complete system will provide a formal demonstration that the Driver Fuel In-Core TFE system will perform as designed after being subjected to simulated launch conditions. A low-risk approach, incorporating qualification of individual assemblies, followed by qualification of a complete system, termed the qualification unit (QU), characterizes this program. This phase will take the system technology to level 8 (flight qualified).

Statement of Work: The required qualification tests for the assemblies of the in-core TI system are those specified in Section 6.4, "Component Qualification Tests", of MIL-STD-1540B. For the QU, the required qualification tests are in Section 6.2, "Space Vehicle Qualification Tests", of MIL-STD-1540B. Qualification will be to launch environmental conditions selected to envelope the probable intensities developed by various launch scenarios.

The overall approach, starts with qualification of assemblies. Qualified production items are then fabricated and assembled into the QU which is then qualified by the rules for space vehicle qualification. This approach minimizes the risk that some assembly of the QU will fail during the qualification test sequence, thereby nullifying the qualification, and requiring backtracking to recover from the failure.

Performance testing at each level will be conducted to verify that each item performs as designed. The qualification item will be similar to the corresponding engineering item and, therefore, performance testing will be less time consuming.

Dynamic testing will be performed per MIL-STD-1540B, to verify capability of the in-core TI system to withstand launch loads, including acoustic, pyroshock and vibrational. The performance and dynamic qualification test sequence for components and assemblies is shown in Figure F-2. Fabrication, assembly, checkout, and testing of the QU will be similar to the corresponding operations for the GES and therefore, will benefit from the experience with the GES. Test facilities for component and assembly qualification testing will be the same as those for the assembly level testing of the QU test program.

When qualification testing is successfully completed, the QU will be scheduled for life testing for nominally 1.5 years (optional).

Task 7. Flight System Program

Objectives: Produce, acceptance test, and deliver one or more flight systems. Take the system technology to level 9 (flight proven).

Statement of Work: In the flight system program, parts will be fabricated, acceptance tested, and assembled. Systems will be subjected to acceptance testing per MIL-STD-1540B guidelines before shipment to the launch site. The same test facilities (vacuum chamber, vibration, acoustic) that were used for the qualification program would be used for flight system acceptance testing. The flight phase of the program also will include the safety studies and reports necessary to obtain launch approval.

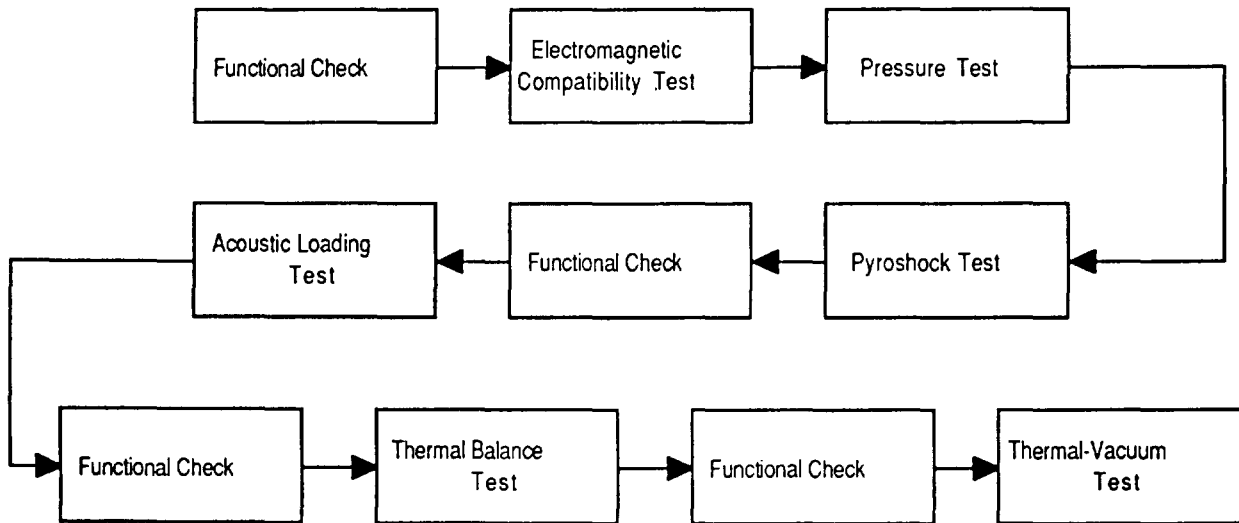

Figure F-2. Thermionic power system QU test sequence (per MIL-STD-1540B).

DEVELOPMENT SCHEDULE

Figure F-3 presents a development schedule for the Fuel Driver In-Core TFE reactor. The total development time to flight is 8.5 years. Development time is expected to be fairly short for this concept since this is a relatively simple system (working fluids always liquid; control done at PP&C; and small radiator) and much of the component technology is state-of-the-art (i.e., stainless steel materials). Significant development work has been done on the TFE elements and the Air Force has recently expressed an interest in developing a relatively high power reactor unit by way of an upcoming RFP.

The program starts with a conceptual design task followed by preliminary design and concurrent component development of the reactor and heat transport components, thermionic fuel elements, and electronic assemblies. The detailed design is subsequently completed by the middle of the third year.

It is expected that the program critical path initially will be through design, development, and fabrication of the thermionic fuel elements. The first complement of TFEs must be ready by the middle of the fourth year for assembly in the GES reactor. From there, the critical path is through the nuclear subsystem, assembly of the qualification system, and finally the testing of the qualification system.

The GES will be similar to a flight system but will have features such as additional instrumentation and readily removable components to expedite gathering of engineering data. It will be tested in a vacuum chamber under normal and off-normal design conditions. After this phase of testing, it will be put on life test for 3 yrs.

The qualification phase includes design, fabrication, assembly, and qualification testing of individual components, and a complete system. The design effort will be minimal since it would involve only minor modifications to the GES design.

The flight phase of the program includes fabrication, assembly, and acceptance testing of the flight units and the associated safety analysis (including Preliminary Safety Analysis Review [PSAR], Updated Safety Analysis Review [USAR], and Final Safety Analysis Review [FSAR]) to obtain launch approval.

THERMIONIC REACTOR POWER SYSTEM TECHNOLOGY ROADMAP

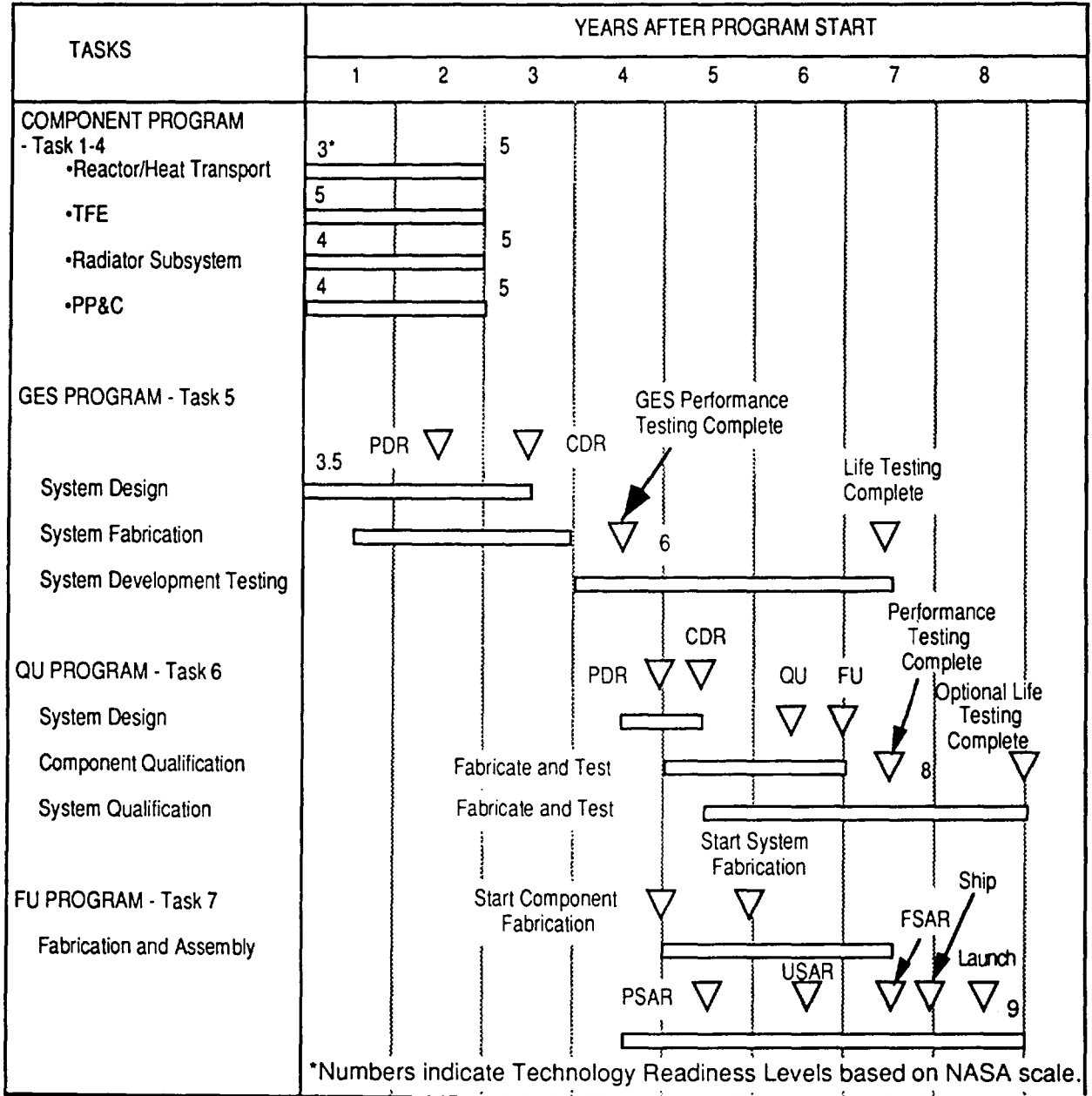

Figure F-3. Fuel driver in-core TFE power system development schedule.

REFERENCES

- F-1. Van Hagan, T.H.; and Mills, J.C.: Fast Driver: A Thermionic Power System for Low Power Applications. Proceedings of the 26th IECEC, Volume 1, August 1991, p.431.
- F-2. Mills, J.C.; and Dahlberg, R.C.: Thermionic Systems for DOD Missions. Proceedings of the Eighth Symposium on Space Nuclear Power Systems, Part Three, January 1991, p. 1088.
- F-3. TFE Fast Driver Reactor System: A Concept for Low Power Applications. Rockwell International (Rocketdyne Division) briefing to USAF Phillips Laboratory, 31 July 1991.
- F-4. Lamp, T.; and Donovan, B.: The Advanced Thermionics Initiative Program. Proceedings of the 26th IECEC, Volume 3, August 1991, p.132.
- F-5. Jalichandra, P.; et. al: Thermionic Critical Technology Investigation. Proceedings of the 26th IECEC, Volume 3, August 1991, p.148.
- F-6. Bohl, R.J; et. al: Thermionic Fuel Element Verification Program - Overview. Proceedings of the Eighth Symposium on Space Nuclear Power Systems, Part Two, January 1991, p. 636.
- F-7. Bohl, R.J.; et. al: Thermionic Fuel Element Verification Program - Overview. Proceedings of the 26th IECEC, Volume 3, August 1991, p.121.

APPENDIX G

INTRODUCTION

The SP-100 program is currently developing a high temperature power reactor coupled to a thermoelectric generating system (Refs. G-1 and G-2). The nominal system power level has been selected as 100 kWe. This system uses SiGe GaP for the thermoelectric power conversion.

Use of the SP-100 reactor on the Martian surface would require that the reactor and any of the power conversion equipment fabricated from refractory alloys be isolated from the Martian environment. Also, recent tests indicated that the lunar regolith is not compatible with refractory alloys; consequently, it would also have to be isolated from the lunar environment.

CONCEPT DESCRIPTION

SP-100 is a joint DOD/DOE/NASA program to develop, qualify and flight demonstrate a space power reactor system. The basic configuration of the system currently being developed by the SP-100 program is shown in Figure G-1. The reactor provides thermal energy to a lithium coolant that is pumped by 12 thermoelectromagnetic (TEM) pump assemblies to an equal number of TE converter assemblies. The TE converter assemblies, located at the rear of the conical structure, convert thermal energy to electrical energy. Waste heat from each Thermoelectric Converter Assembly (TCA) is rejected to a secondary lithium loop which transports the waste heat to heat pipe space radiator panels. The radiator panels are deployable by use of flexible bellows in the secondary lithium lines. Generated power is conditioned for the user in the power processing module, which establishes the primary mechanical and electrical interfaces with the mission payload.

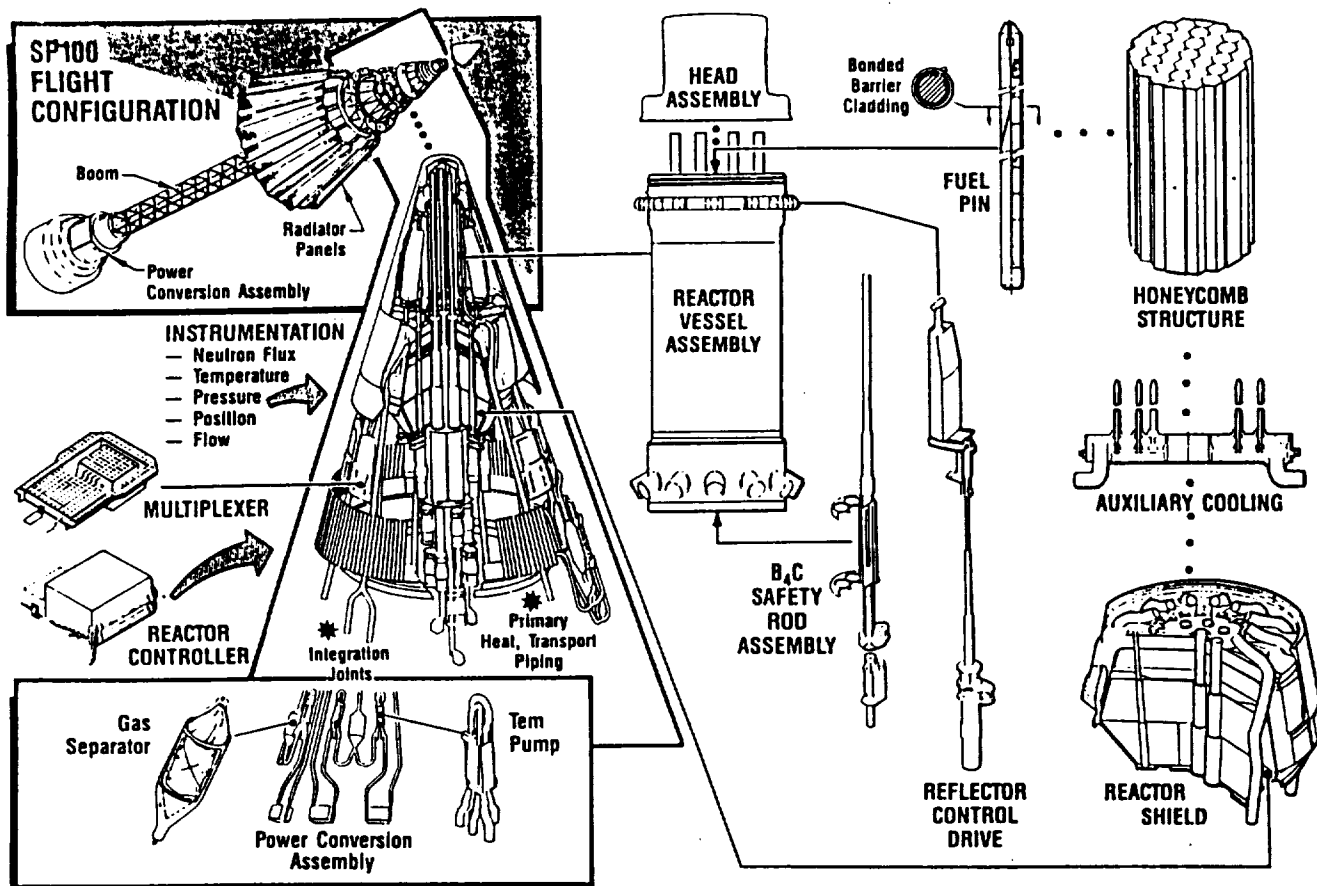

Figure G-1. SP-100 TE generic flight system configuration.

Figure G-1 illustrates the SP-100 Generic Flight System (GFS) configuration. The configuration will require considerable modification for surface applications to provide containment of the refractory alloy components, provide additional shielding consistent with the emplacement geometry, and reconfigure the radiator geometry for packaging.

The reactor designed for the SP-100 system is a fast spectrum design with sealed uranium nitride (UN) fuel pins contained in a single vessel with liquid lithium circulated as the coolant. The reactor is approximately 0.55 meters in diameter by 0.75 meters high. Twelve sliding block reflector control segments provide reactivity control through neutron leakage. PWC-11 refractory metal is used for the reactor fuel pin cladding and for the reactor structure. Three large safety rods are inserted into the reactor core during launch and ascent and are extracted only after a nuclear safe orbit is achieved. The reactor is nominally rated at

2.4 MWt and delivers its thermal energy to liquid lithium at 1350 °K. SP-100 design goals, requirements, and design features for the generic flight system are shown in Table G-1.

TABLE G-1. SP-100 GENERIC FLIGHT SYSTEM DESIGN GOALS, REQUIREMENTS AND FEATURES

Parameter	Requirement	Design Feature (s)
Design lifetime	7 years	<ul style="list-style-type: none"> •Fuel inventory •Fission gas accommodation
Reliability	0.95	<ul style="list-style-type: none"> •TE conversion flight proven •Established reactor data base
Main bus power	100 kWe	<ul style="list-style-type: none"> •Modular design provides scalability
Main bus voltage	200 Vdc	<ul style="list-style-type: none"> •Option range (28 to 400) readily provided
Load following	Rapid, continuous	<ul style="list-style-type: none"> •Full shunt
Shielded diameter at user interface	15.5 m (50 ft)	<ul style="list-style-type: none"> •Larger areas provided at minimum penalty
Radiation at user interface	1.0×10^{13} n/cm ² 5×10^5 Rad	<ul style="list-style-type: none"> •Reactor shield assembly
Thermal flux at user interface	0.07 W/cm ²	<ul style="list-style-type: none"> •Meets specified requirement (0.14 W/cm²) •Easily moderated by boom length
Solar orientation	No restrictions	<ul style="list-style-type: none"> •Full sun design for radiator
Natural radiation and meteoroids/debris	Mass allowance in baseline for worst case envelope	<ul style="list-style-type: none"> •Meteoroid armor radiator shields

The flight system radiation shield is mounted directly behind the reactor and consists of both gamma and neutron shield segments. The gamma shield consists of depleted uranium. The neutron shield is made up of a series of axial lithium hydride sections with intervening thermal conductors that carry the gamma and neutron generated heat to the shield's radial surface where it is radiated to space. Shielding for planetary applications may be configured to maximize the use of indigenous materials. Alternatively, where deployment time and effort must be minimized, a 4Π shield configuration could be included with the reactor system design.

Thermal transport is accomplished by liquid lithium that is pumped by 12 thermoelectric driven electromagnetic pumps. The TEs for the pumps are powered by the temperature differential between the working fluids in the primary and secondary loops. This approach ensures pumping of the working fluid as long as the reactor is at an operating

temperature higher than the heat rejection loop. It also facilitates cooldown of the reactor with removal of decay heat when electrical power to the payload is no longer required. A pair of supply and return lines feed the liquid lithium to the 6 thermopile heat exchangers located in each Power Conversion Assembly (PCA). The supply and return lines are connected to common headers located within the reactor subsystem. The TEM pumps are located between the PCA and the common return header to the reactor vessel as shown in Figure G-2. The secondary lithium lines provide cooling to the power conversion assemblies and the TEM pumps while transporting the waste heat to a liquid manifold located on the centerline of each of the 12 radiator panels. The lithium is in a frozen condition until system startup. Thawout of the lithium for lunar surface application is accomplished using electrical trace heaters.

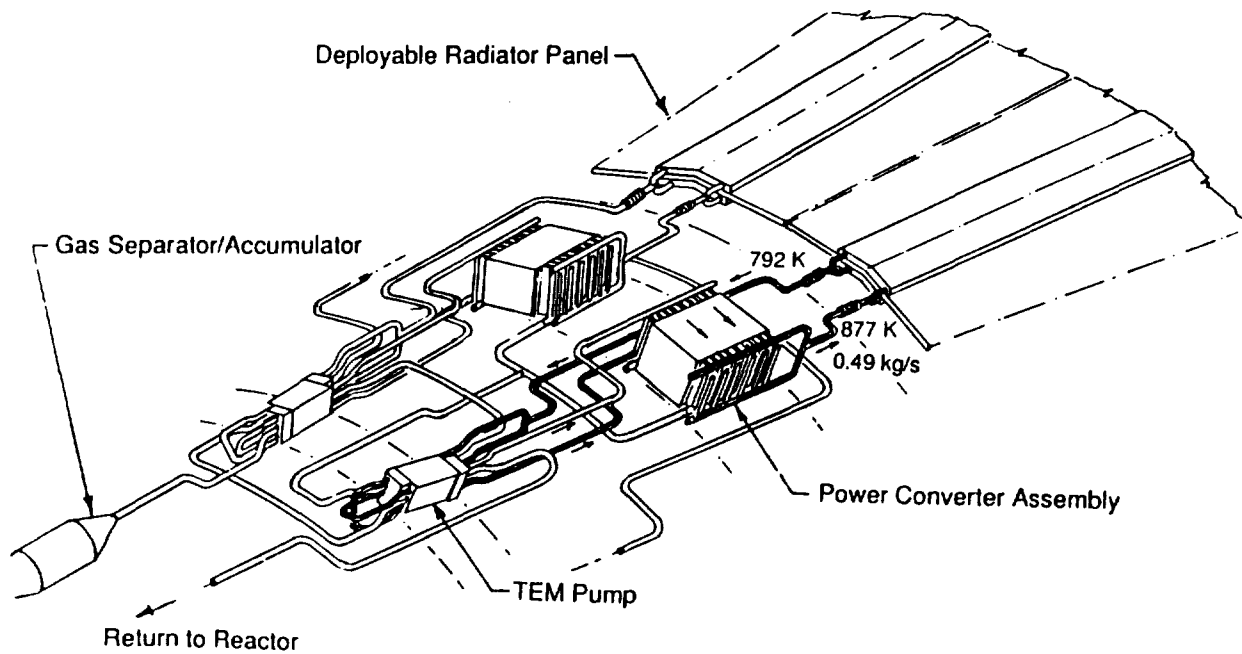

Figure G-2. Radiator interface with heat transport piping.

Figure G-3 illustrates the detail design of the SP-100 TE cell. Each cell consists of 24 thermocouples electrically arranged with four rows or strings of six couples each. The "N" and "P" TE legs are connected at the hot and cold ends by electrical straps to form the series electrical arrangement. The electrical straps extend laterally to intertie the four strings electrically in parallel. This results in an electrical intertie at every half couple. Terminals at each end of the cell provide the series connections to adjacent cells. Low voltage electrical insulators provide insulation for the 1.0 volt potential within the cell outboard of the electrical straps. The compliant pads are outboard of these insulators and are used for differential thermal expansion. Finally, outboard of the pads, 100 volt insulators are used to insulate the cells from the heat source and the radiator subsystems.

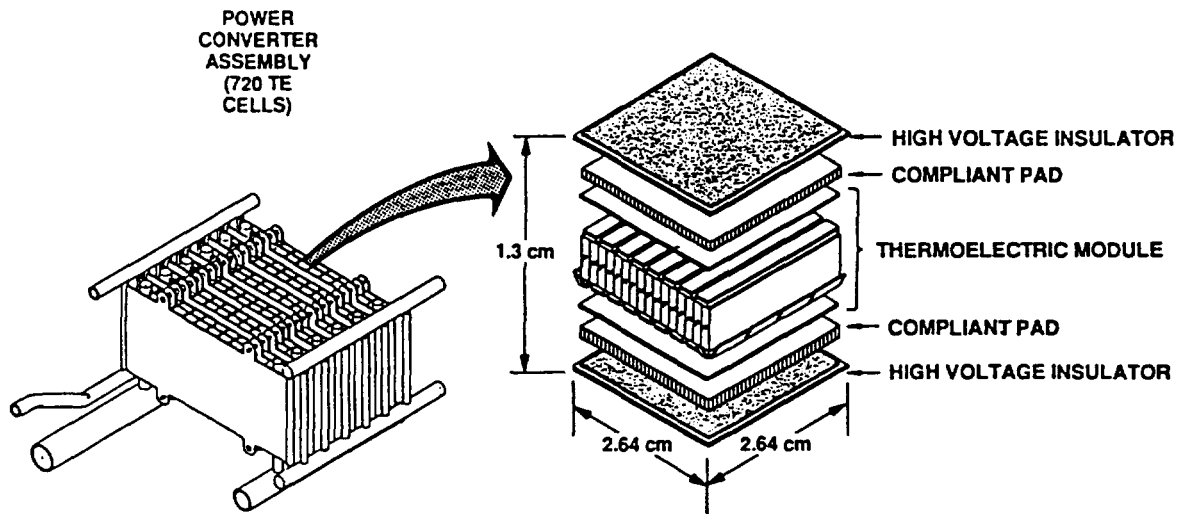

Figure G-3. Thermoelectric cell design.

The radiator panels use heat pipes to transport heat from the liquid lithium secondary manifolds along the length of the panel. The current design approach uses a carbon-carbon heat

SP-100 POWER SYSTEM TECHNOLOGY ROADMAP

pipe radiator panel with potassium as the working fluid and a thin metal niobium liner to prevent contact between the potassium and the carbon-carbon structure.

The power conditioning electronics and shunt dissipators are located on a remote power processing module that remains attached to the payload after the boom is deployed. The shunt regulator provides +/-2% voltage tolerance on a nominal 200 Vdc output and is capable of load following without restriction as long as loads do not exceed the power generation level capability. The remote location provides several distinct advantages. It allows state of the art electronics to be used with standard materials of construction. If located near the reactor, the electronics would be required to operate in relatively intense nuclear and thermal radiation fields.

KEY ISSUES

The key issues for the SP-100 GFS are summarized in Table G-2.

TABLE G-2. SUMMARY OF KEY ISSUES AND IMPACTS

Issues	Impacts	Potential Development Areas
High development cost and risk	<ul style="list-style-type: none"> •Increased life cycle cost and schedule •Heavier system specific mass 	•Accelerated (high-risk) development program
Safety of nuclear systems during operation	•Increase in system mass for shielding - may be especially significant if in-situ materials are not used	•Use of in-situ materials for shielding
Low PCA efficiency compared to other PCA options	•Increased launch mass and costs	•Dynamic SP-100 or in-core TI reactor system
Limited TE system power level	<ul style="list-style-type: none"> •May require multiple systems - increases installation effort and time •New development program to develop higher power systems would be costly 	•Parallel development of dynamic SP-100 power system designs

TECHNOLOGY ASSESSMENT

The technology bases were assessed for the following major SP-100 assemblies:

- SP-100 space power reactor and primary loop;
- thermoelectric power conversion;
- heat rejection subsystem; and
- power processing and control.

The technology readiness of each assembly was evaluated using the NASA technology readiness levels (1-9). These evaluations are summarized in Table G-3 which shows that SP-100 assemblies have technology readiness levels ranging from 3 to 4. The technology base for each assembly is briefly discussed in the following sections and summarized in Figure G-4.

TABLE G-3. SP-100 TECHNOLOGY ASSESSMENT

Assembly	Technology Readiness Level	Comments
SP-100 Reactor and Primary Loop	3	Currently funded development program
Thermoelectric Power Conversion	3	Good progress in development program
Heat Rejection Subsystem	4 / 3 *	Currently under development
Power Processing and Control	4	Radiation hardened electronics

*All-metal heat pipe/carbon-carbon heat pipe.

SP-100 Space Reactor and Primary Loop State-of-the-Art

The SP-100 power reactor is actively being developed by the General Electric Corporation under a joint DOD/DOE/NASA contract. Considerable progress has been made in the development with the expenditures of more than \$420M to date.

A fuel pin irradiation testing program has demonstrated the capability of the generic flight system fuel pin to meet performance requirements that call for full power operation to about 6.0 atom percent burnup for seven years. Irradiation tests have included UN fuel pins with Nb-1Zr cladding and tungsten or rhenium liners, rhenium liners bonded to Nb-1Zr cladding, and rhenium cladding. The accelerated tests (fluences and burnup levels are achieved

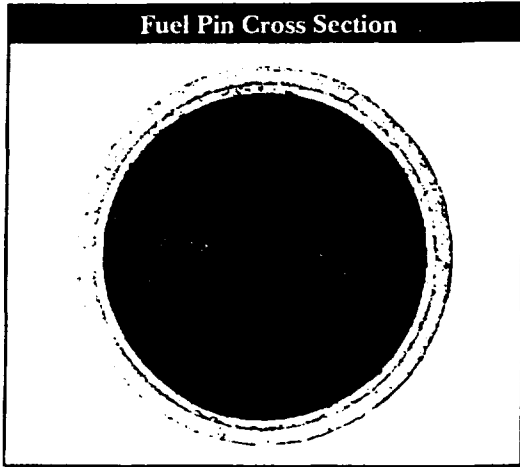

Fuel Pins

76 UN fueled pins with Nb-1Zr/rhenium cladding have been in-reactor tested to full burn-up with no failures. The manufacturing processes are qualified and technology readiness has been achieved.

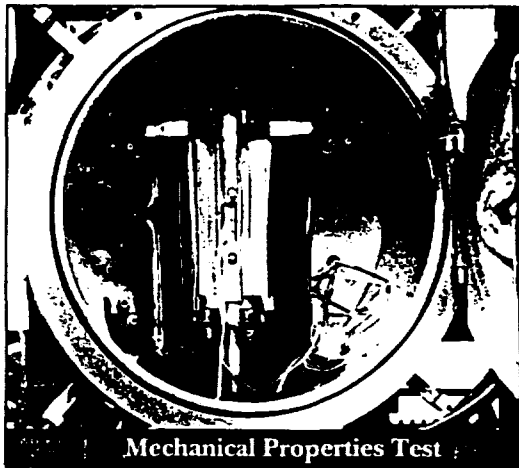

Materials

Nb-1Zr and PWC-11 refractory metal mechanical properties tests and irradiation experiments provide high confidence in meeting all requirements for full ten year life.

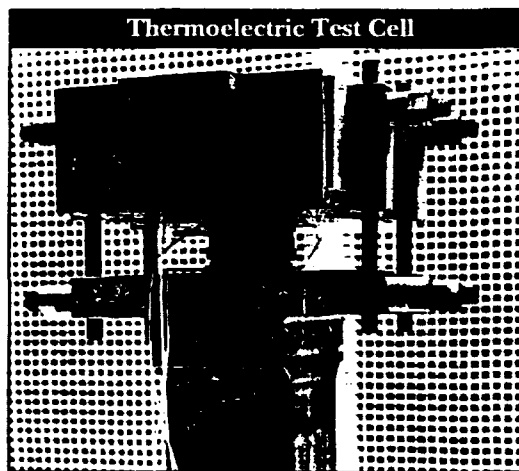

Thermoelectrics

2nd generation TE cell ingradient tests produced 8.7 watts. Full power, with SiGe cells, is expected in next generation tests. High-voltage insulator and compliant pad tests, conducted under prototypic conditions, provide high confidence in meeting all requirements.

Figure G-4. SP-100 hardware development.

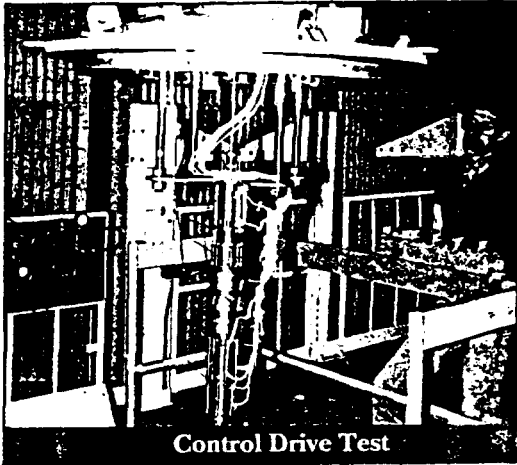

Control Systems

Prototypic first generation control components (clutches, motors, brakes, bearings and coatings) have been developed and tested in high temperature high vacuum environments. Feasibility has been demonstrated.

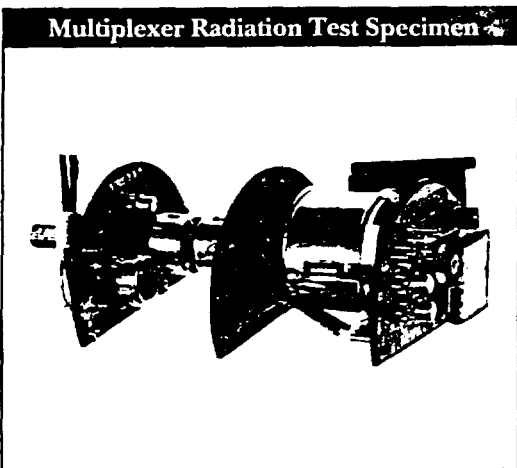

Radiation Hard Electronics

Feasibility has been established through testing of electronic parts required for signal multiplexing in a high gamma and neutron environment. End-to-end signal verification of special sensors, such as the Johnson Noise Temperature Sensor, has been achieved.

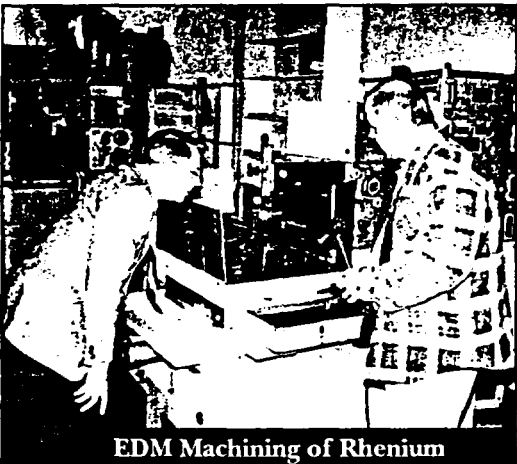

Refractory Fabrication

Fabrication procedures and specifications are qualified including welding, EDM machining, bonding and cold forging. Compatibility of Nb-1Zr/-PWC-11 welding and bonding has been demonstrated by over 2000 hours of testing at 1350 °K.

Figure G-4. SP-100 hardware development (continued).

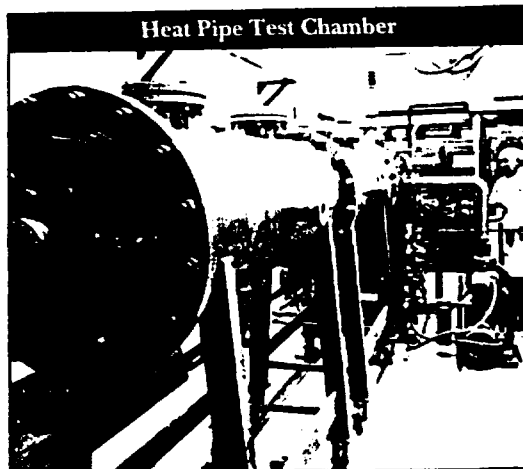

Heat Pipes

Nb-1Zr, titanium and stainless steel foil wick heat pipes with potassium working fluid, have been tested for over 7500 hours at 885 °K. Repeated restart capability has been demonstrated.

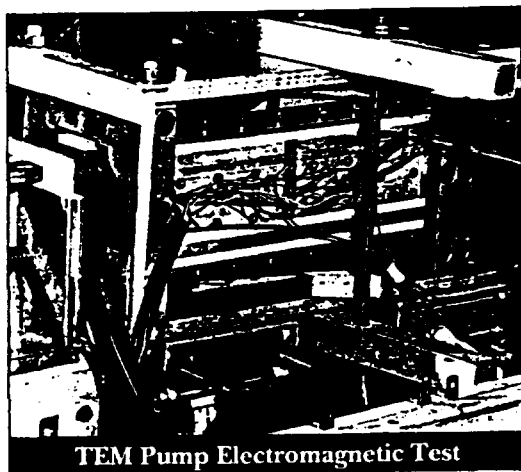

Component Testing

Control drives, TEM pump and electronic components have been under feasibility and prototypic environmental testing. A component test loop is being constructed for flight prototypic testing in lithium at 1400 °K. Testing of TEM pumps, TE converter assemblies and radiator panel segments will be conducted to demonstrate technology readiness.

Figure G-4 SP-100 hardware development (completed).

in a fraction of the actual service durations) will provide the information required for formulating the analytical models and validating the fuel pin design. Extended life testing is not planned.

Nuclear assembly fabrication development was investigated and a process to extrude nozzles in the inlet/outlet nozzle course portion of the reactor vessel. A demonstration nozzle has been formed to the correct dimensions by the extrusion process at room temperature.

Nb-1Zr weld specimens have been exposed to lithium to evaluate the effect of welding atmosphere purity and post weld heat treatment on the sensitivity to lithium attack at grain boundaries. Results of the tests indicate that the welds containing bulk oxygen contents greater than 176 ppm experienced lithium attack at the Nb-1Zr grain boundaries. No attack was observed for bulk oxygen levels less than 140 ppm. The results of this work indicate that if low oxygen levels are maintained during welding, the potential for lithium attack is essentially eliminated.

Nondestructive examination methods continued to be developed and improved with most efforts being concentrated on support of the barrier fuel program. Production techniques for nondestructive testing of bonded fuel tubes were developed. A microfocus rod anode X-ray system was used in conjunction with ultrasonic testing to evaluate the detection of defects in various weld configurations.

A reactor flow test was completed including test article fabrication, test planning, and the completion of a comprehensive series of tests. Results of the test program provide important fuel assembly hydraulic design correlations as well as a validated orifice sizing procedure. TEM pump electromagnetic tests are being performed to verify magnetic circuit performance predictions. A test loop is being constructed for primary loop component prototypic testing in lithium at 1400 °K. The technology readiness level of the SP-100 reactor assembly and primary lithium loop components is judged to be at level 3. Sufficient background work has been done to enable the fabrication and testing of a breadboard model to be started.

Thermoelectric Power Conversion Device State-of-the-Art

A first generation TE cell (PD-1) has been fabricated and tested. This cell incorporated the key features of the prototypic design (high voltage insulator, compliant pad, TE module, and module glass) but was limited in power output by several features which resulted from the state of the technology at the time. Most notable of these features were: (1) the incorporation of graphite layers between the compliant pads and the TE module for the purpose of compensating

for a coefficient of thermal expansion (CTE) mismatch between those parts; (2) and the limitation of the maximum hot side temperature due to the use of copper braze which was used since the high temperature braze had not yet been fully developed. These features limited the expected output power to approximately 5 watts. This power level compares to an expected 11 watts for a prototypic cell using SiGe T/E legs and 13 watts for one using SiGe/GaP TE legs. The test did demonstrate the ability to predict the cell performance as a function of cell configuration and test conditions. It was the first demonstration that the SP-100 conductively coupled, multicouple cell concept would work under in-service conditions using the enabling features of the high voltage insulator and the compliant pad.

Tests have recently been completed on a second generation cell. Designated PD-2, the design eliminates the graphite layers and low temperature braze features of the PD-1 design to more closely approach the prototypical design. The PD-2A cell yielded 8.7 watts. Figure G-5 summarizes the thermoelectric multicell development effort under the SP-100 program to date.

In addition to the development of TE cells, significant accomplishments have been made in the development of single crystal alumina high voltage insulators, tungsten/graphite compliant pads, and electrodes. These factors contribute to the TE cell technology level rating of 3.

Heat Rejection Subsystem (HRS) State-of-the-Art

Heat rejection loop components operate at less than 900 °K and thus, there are no major materials problems with this subsystem. Radiator manifold liquid-metal thaw experiments have indicated that the GE manifold design using bleed holes to promote progressive melting of the frozen metal coolant within the manifold may be feasible.

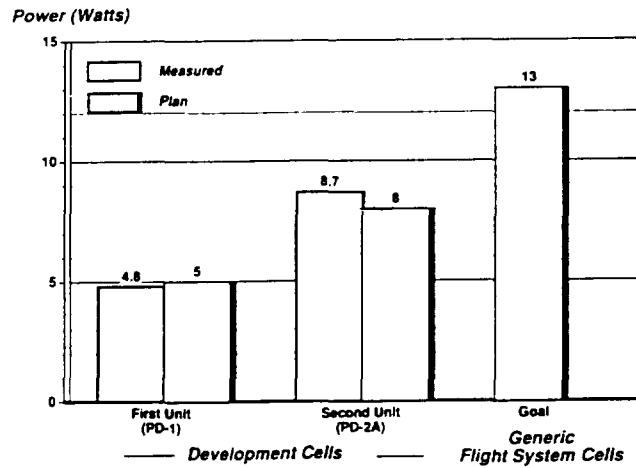

Figure G-5. SP-100 conductively coupled multicouple evolution.

Development of the GE heat pipe radiator/manifold assembly design, which uses a titanium lined beryllium structure with potassium as the heat pipe working fluid, has been delayed in order to permit more resources to be devoted to reactor development and in anticipation of the successful development of a carbon-carbon configuration. A program to develop advanced radiator concepts for SP-100 power systems was initiated by NASA-LeRC in 1987. To meet the SP-100 requirements, while minimized mass, a carbon-carbon heat pipe radiator concept was selected.

The "SP-100 Advanced Radiator Concepts" program, which started in 1987 as part of the CSTI (Civilian Space Technology Initiative) program, will be completed in January of 1993. This program involves development of a C-C heat pipe suitable for use in an SP-100 radiator assembly. However, this technology will be suitable for other radiator applications as well including other nuclear and non-nuclear power systems. This program will develop generic technology which can be used for all future space radiators because of its reduced mass compared to metal heat pipe radiators. Carbon-carbon is a new structural material which requires different fabrication techniques than for metals or composites. A key objective of this program is to demonstrate the ability to fabricate C-C heat pipes with a thin metal liner, wicks, caps, and fill tube. The brazing technique required to attach liners is the same as would be required to attach manifolds to the heat pipes. Heat pipes filled with potassium will be designed, fabricated, and tested during this program. Thermal cycle testing will be done in a vacuum to demonstrate the integrity of the heat pipes. No mechanical testing for stress or shock are planned.

The current technology level of the radiator subsystem is estimated to be about 4 for the all-metal heat pipe radiators and about 3 for carbon-carbon heat pipe radiators.

Power Processing and Controls (PP&C) State-of-the-Art

The electronic component technology required for the SP-100 power processing equipment is being developed for future power system applications under the SP-100 program. Currently available analytical and design technologies will be used along with radiation hardness testing. Radiation hardened high reliability Class S parts will ensure that a reliable and low risk power processing and control system is provided. Rockwell is currently developing the Space Station Freedom (SSF) Electrical Power Subsystem; some of this technology is directly transferable to SP-100 lunar and Mars surface power systems concepts. The use of multiple buses, components for the switching of loads, and switching of subassemblies within the power assembly are technologies common to the two programs.

Several active efforts are underway to develop expert system techniques for real-time control applications. These include a design for the evaluation of Space Shuttle Main Engine (SSME) performance, sensors and data processing for fault detection, and the electrical load power allocations in the SSF electrical power subsystem. The algorithms for power scheduling and balancing on the space station are in development. Expert system software for the SSF electrical power subsystem is being developed using the ADA environment. This work includes implementing and evaluating an ADA based inference engine, which will enable an expert system to run on standard microprocessors for SSF applications.

The required technology for the control and data acquisition functions currently exists, and the technology for autonomous control is under active development for Space Station Freedom (SSF), ESSA and other space power programs. The need for radiation hardened components with these capabilities remains to be demonstrated, which results in a technology rating of 4.0 for the PP&C subsystem.

MAJOR DEVELOPMENT TASKS

The technology level of SP-100 components range from 3 to 4, and therefore development testing is required. The testing currently envisioned is briefly described in the following sections.

Task 1. SP-100 Space Power Reactor Development

Objectives: Complete development testing of the reactor components so that the final reactor design can proceed with a high degree of confidence and allow the ground engineering and flight test programs can be completed on schedule.

Statement of Work: Complete additional test and evaluation efforts to verify the utility of several mass reduction design features which include the safety rods, the aft axial reflector, the sliding radial reflector control, the hemispherical reactor vessel head, the in-vessel thaw accumulator, and materials changes in the shield vessel. Other development areas include the

verification of the reactor design; completion of the fuel pin irradiation test program, fabrication methods development, NDE development, multiplexer development, temperature sensor development, pressure sensor development, materials of construction development, verification of control drive assembly design, and the development of tribological coatings. Develop the thermoelectric electromagnetic (TEM) pump power supply and demonstrate the feasibility of the pump design in a 1400 °K lithium environment.

Task 2. Thermoelectric Power Conversion Device Development

Objectives: Complete development of TE power conversion devices with improved performance.

Statement of Work: Additional development efforts in the areas of cell technology development and life verification will continue. Continued development is required in the high voltage insulator, compliant pad, and electrode development areas. Accelerated life testing of molybdenum barrier equipped insulators is being conducted. The development of a tungsten-graphite bilayer electrode for use in the third generation cell is continuing. Significant development work is currently being concentrated on the thermal conductivity reduction in fine particulate p-type SiGe material. Increases in performance of the thermoelectric conversion material of 30 to 40 % have been predicted if the thermal conductivity can be reduced by adding several volume percent of 50 angstrom particles to the materials matrix.

Additional development effort is needed in the areas of SiGe/UT87 bonds. Also effort is required to find a graphite material that has better strength than UT87. Materials with a finer grain size or possibly the use of carbon-carbon composites would be appropriate. Compliant pad materials development also requires additional development effort. Near term efforts will be directed toward the development of more flexible materials which do not diffusion bond and lose their flexibility.

Task 3. HRS Development

Objectives: Develop and test a small scale radiator panel. Develop and test a full scale heat pipe radiator/interface heat exchanger assembly.

Statement of Work: The following subtasks are identified:

Subtask 3.1 Heat Pipe Demonstration - Various development efforts are required to bring heat pipe technology to a space qualifiable level. This effort is assumed to be a follow-on to the Rocketdyne "SP-100 Advanced Radiator Concepts" contract. Specific efforts include performance testing, life testing, and nondestructive evaluation.

For performance testing, representative length heat pipes will be fabricated and tested to fully characterize heat pipe performance. Test results will be compared with predicted performance over the anticipated range of operating conditions including startup, shutdown, and restart.

Limited life testing will be performed. These tests will identify deterioration mechanisms, measure deterioration rates, and assess the adequacy of assembly and cleaning procedures. Samples will be withdrawn sequentially throughout the test period, drained, sectioned, and analyzed for corrosion, carbon diffusion, braze stability, and any other signs of deterioration.

In conjunction with the performance and life testing tasks, techniques for nondestructive examination (NDE) of the heat pipe elements and assembly will be developed and demonstrated. This effort will assess the adequacy of liner bonding and weld joints. It will also be determined if the correct fit-ups and interfaces were obtained in the assembled piece.

Subtask 3.2 Radiator Enhancement - To increase the applicability of the radiator concept, various enhancement tasks will be performed. These tasks include survivability options and extended length heat pipes.

Analytical assessment, testing, and enhancement design will be done to insure long life for both lunar and Mars missions. Natural threats to be considered include micrometeoroids and dust erosion (Mars).

Significant radiator performance improvements can be achieved with the use of longer heat pipes in some applications. A long heat pipe will be fabricated. Alternate techniques will be developed for fitting the liner into the tube will be developed. Alternative tube fabrication, liner fabrication, and coating processes will also be investigated.

Subtask 3.3 Heat Pipe Integration and Testing - The first step in this task is to develop and demonstrate techniques for thermal and mechanical bonding of the heat pipe to the radiator manifold. Subsequently, heat pipe integration into a representative radiator section will be demonstrated. Testing of the radiator section will be done to provide an accurate overall heat transfer coefficient. System dynamics and performance will also be verified. The demonstrator will include a surrogate manifold section and a limited number of heat pipes. The assembled unit will be tested in a cold wall, vacuum chamber, simulated space environment. The purposes of this series of tests will be to validate temperature drop predictions, verify manifold design, and assess component interactions.

Subtask 3.4 HRS Design, Assembly, Fabrication, and Testing - This task will provide a focus for the other radiator development tasks. This task will involve the detailed design of a radiator system. Specific design issues will be resolved including the effects of differential thermal expansion, deployment features, monitoring instrumentation and control equipment, local insulation, and trace heating of the manifold and piping.

A representative full scale heat pipe radiator and interface heat exchanger will be designed, fabricated, and tested. Testing will include performance, mechanical (stress, shock, and vibration), thermal cycling, and life tests.

Task 4. Power Processing and Controls Development

Objectives: Complete development of radiation hardened components. Verify adequate performance and life.

Statement of Work: Breadboard units will be built to demonstrate and check functional performance of the individual component circuit designs. Design modifications and

improvements will be incorporated into brassboard units, which will be used to verify functional performance within the constraints of the actual component configuration. Prototype units will be fabricated and a series of performance tests run using simulated input and output loads. Controller tests will include validation of operating system software. Tests will include:

- Start up, steady state and transient control;
- failure simulation and detection and switching;
- effects of temperature extremes and thermal shock;
- shock and vibration;
- cold plate heat loads; and
- EMI generation and susceptibility.

Prototype cable harnesses and a prototype parasitic load radiator will be checked out with the electrical components during the system test.

Software will be checked out in conjunction with tests of the controller, using simulated inputs and outputs. Integration and checkout of the software will be performed as part of the system test.

Task 5. Ground Engineering System (GES) Testing

Objectives: Complete the system design. Verify all performance characteristics of the unit in conjunction with subjecting the GES to MIL-STD-1540 acceptance level tests. Take the system technology readiness to a level of 6 (system validation model demonstrated in a simulated environment).

Statement of Work: As a cost reduction measure it has been proposed that GES testing be dispensed with and that space reactor power programs proceed to the flight qualification phase after the component development needed to support final design has been completed. Since acceptance of this approach by the technical community is not certain as of this writing, a

discussion of GES testing is included as part of the overall development of a space reactor power system.

After assembly, the GES will be pressure and leak checked, as appropriate, a complete electrical check-out will be performed, and all active devices will be checked out to the extent possible.

Performance and thermal vacuum tests will be conducted during a single thermal vacuum test sequence to demonstrate technical capabilities while minimizing program cost. The performance evaluation will consist of the following major activities:

- Check out and refine subsystem assembly procedures;
- check out procedures for loading coolant into the reactor coolant loop;
- verify operation of ground support equipment (GSE) and interfaces between GSE and the GES;
- check out ground cooling systems as required;
- verify start up capability;
- verify steady state performance characteristics;
- establish effective operating range of the system;
- check out software and verify autonomy (include all operational modes and simulate failure modes);
- establish system sensitivity to off-normal conditions such as: (1) partial loss of radiator cooling, (2) varying radiator heat removal profile, (3) partial loss of electronic cooling, and (4) temporary losses of heat sink with varying duration; and

The MIL-STD-1540 test sequence will integrate acceptance level and design margin tests as appropriate up to qualification levels, to provide a technically sound, minimum cost approach.

When the performance, acceptance, and margin tests are complete, the GES will be refurbished and will be disassembled for Post Irradiation Examination (PIE).

Task 6. Qualification Program

Objectives: A comprehensive performance and dynamic testing program for assemblies and the complete system will provide a formal demonstration that the SP-100 system will perform as designed after being subjected to simulated launch conditions. Minimize risk by first qualifying individual assemblies and then qualifying a complete system, termed the qualification unit (QU). Take the system technology readiness from a level of 6 to a level of 8 (flight-qualified system).

Statement of Work: The required qualification tests for the assemblies of the SP-100 system are those specified in Section 6.4, "Component Qualification Tests", of MIL-STD-1540B. For the QU, the required qualification tests are in Section 6.2, "Space Vehicle Qualification Tests", of MIL-STD-1540B. Qualification will be to launch environmental conditions selected to envelope the probable intensities developed by various launch scenarios.

The overall approach, starts with qualification of assemblies. Qualified production items are then fabricated and assembled into the QU which is then qualified by the rules for space vehicle qualification. This approach minimizes the risk that some assembly of the QU will fail during the qualification test sequence, thereby nullifying the qualification, and requiring backtracking to recover from the failure.

Performance testing at each level will be conducted to verify that each item performs as designed. The qualification item will be similar to the corresponding engineering item and, therefore, performance testing will be less time consuming.

Dynamic testing will be performed per MIL-STD-1540B, to verify capability of the SP-100 system to withstand launch loads, including acoustic, pyroshock and vibrational.

The performance and dynamic qualification test sequence for components and assemblies is shown in Figure G-6. Fabrication, assembly, checkout, and testing of the QU will be similar to the corresponding operations for the GES and therefore, will benefit from the experience with the GES. Test facilities for component and assembly qualification testing will be the same as those for the assembly level testing of the QU test program. Various component and breadboard subsystems may be demonstrated in space for additional validation.

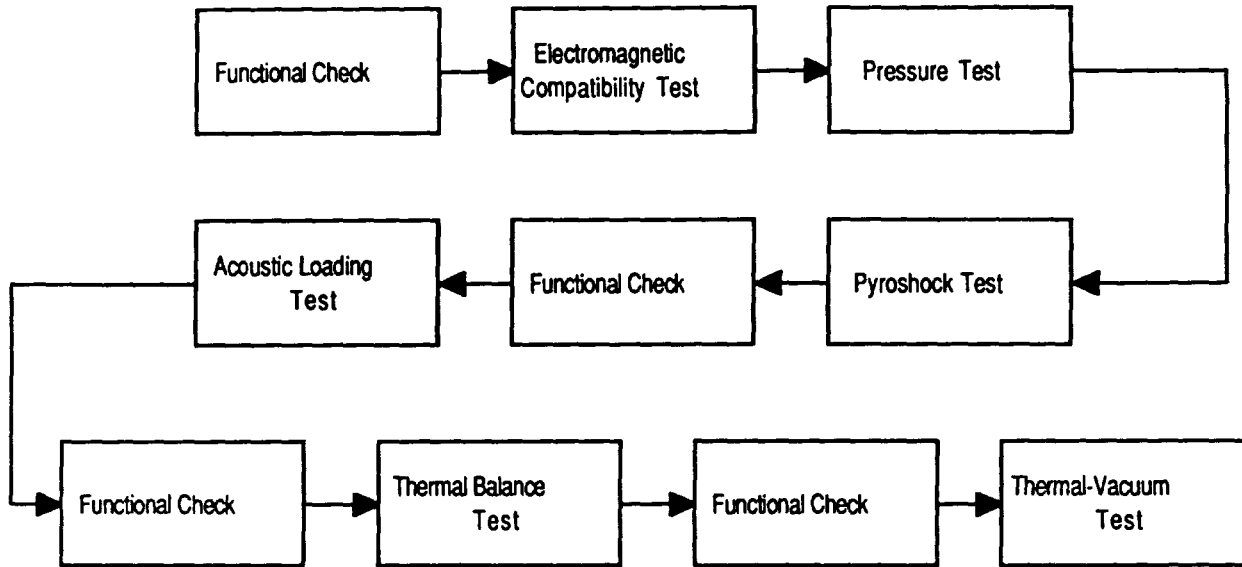

Figure G-6. QU test sequence (per MIL-STD-1540B).

Task 7. Flight System Program

Objectives: Produce, acceptance test, deliver, and launch one or more flight systems. Show successful performance for actual application in space. Take the system from a technology readiness level of 8 to a level of 9 (flight-proven system).

Statement of Work: In the flight system programs, parts will be fabricated, acceptance tested, and assembled. Systems will be subjected to acceptance testing per MIL-STD-1540B guidelines before shipment to the launch site. Many of the same test facilities (thermo-vacuum chamber, vibration, acoustic) that were used for the qualification program would be used for flight system acceptance testing. The flight phase of the program also will include the safety studies and reports necessary to obtain launch approval.

DEVELOPMENT SCHEDULE

The SP-100 program is currently funded but has been experiencing year by year funding reductions that are resulting in significant schedule slippage. Resolution of the funding

question will become more apparent with the identification of a specific mission. No mission has been identified to date. A significant amount of development work has been accomplished and the program will probably be ready to start preliminary design with another 3-4 years of component development effort.

Figure G-7 presents a development schedule for the SP-100 TE generic flight system (additional effort would be required to modify the design for compatibility with a Martian environment). The program starts with a conceptual system design task followed by preliminary system design. Concurrently with the system design, the reactor, power conversion unit, heat rejection subsystem, and power processing and control components will be developed. The preliminary system design is complete by the middle of the seventh year. The detailed system design is subsequently completed by the middle of the eighth year.

Fabrication of components for ground testing for the GES starts with the development and testing of component hardware. The procurement of long lead materials and equipment in the first part of the fourth year leads to assembly of the system in the last half of the eighth year.

The GES will be similar to a flight system but will have features such as additional instrumentation to expedite gathering of engineering data and to permit PIE of components. It will be tested in a vacuum chamber under normal and off-normal design conditions. After this phase of testing, it will be partially disassembled and examined.

The qualification phase includes design, fabrication, assembly, and qualification testing of individual components, and a complete system. The design effort will be minimal since it would involve only minor modifications to the GES design.

The flight phase of the program includes fabrication, assembly, and acceptance testing of the flight units and the associated safety analysis to obtain launch approval.

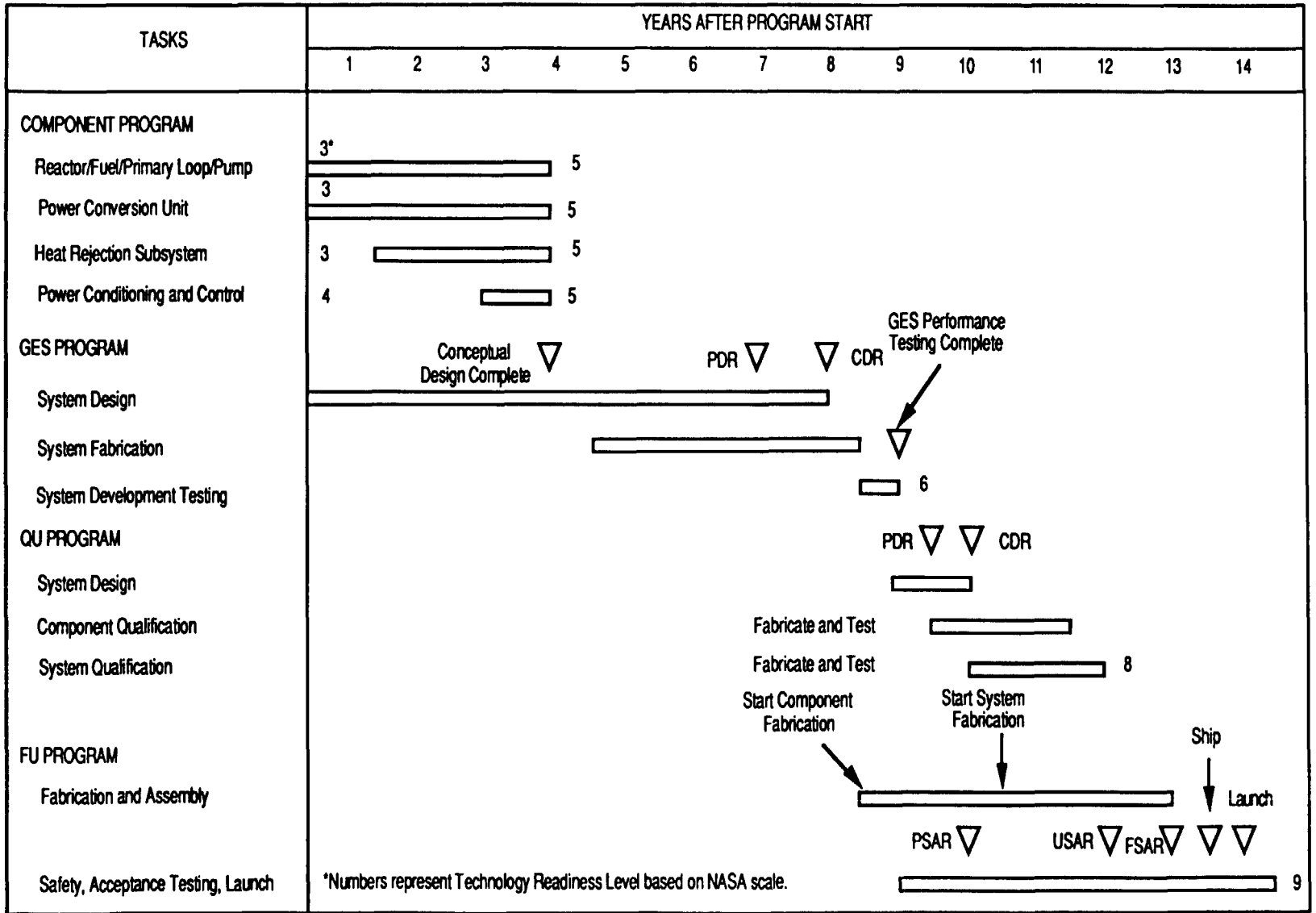

Figure G-7. SP-100 TE generic flight system development schedule.

SP-100 POWER SYSTEM TECHNOLOGY ROADMAP

REFERENCES

- G-1. Mondt, J.F.: SP-100 Space Subsystems Development Process. AIAA paper 91-3584, AIAA/NASA/OAI Conference on Advanced SEI Technologies, September 1991.
- G-2. Armijo, J.S.; et. al: SP-100 Progress. AIAA paper 91-3588, AIAA/NASA/OAI Conference on Advanced SEI Technologies, September 1991.
- G-3. Lunar Electric Power Systems Utilizing the SP-100 Reactor Coupled to Dynamic Conversion Systems. NASA Lewis Research Center Contract NAS3 25808, Rockwell International (Rocketdyne Division), NASA Contractor Report, October 1991.
- G-4. Harty, R.B.; Durand, R.E.; and Masin, L.S.: Lunar Electric Power Systems Utilizing the Sp-100 Reactor Coupled to Dynamic Conversion Systems. AIAA paper 91-3520, AIAA/NASA/OAI Conference on Advanced SEI Technologies, September 1991.
- G-5. Upton, H.; et. al: The Application of SP-100 Technology in a Lunar Surface Power System. AIAA paper 91-3584, AIAA/NASA/OAI Conference on Advanced SEI Technologies, September 1991.

APPENDIX H

INTRODUCTION

Space Nuclear Reactor Power Systems (SNRPS) are primarily suitable for application to satellites with high power requirements and fixed base high power planetary surface applications. Currently envisioned systems include power levels of 25 and 75 kWe for use on the surface of Mars and 100 and 550 kWe units for use on the Moon.

The SNRPS units can be integrated with dynamic or static power conversion systems to provide electric power. The SP-100 program is currently developing a high temperature power reactor coupled to a thermoelectric (TE) generating system. The nominal system power level has been selected as 100 kWe. This system makes extensive use of refractory materials and could be used on the lunar surface.

It was assumed that an advanced SNRPS using a dynamic power conversion system would be developed following development of the SP-100 TE power system (some time after the completion of testing of the Ground Engineering System). The electrical power output of the basic reactor can be significantly enhanced by the use of dynamic power conversion technologies. Dynamic power systems concepts include Closed Brayton Cycles (CBC), Stirling Cycles (SC), and Potassium Rankine Cycles (PRC) integrated in various ways with the nuclear power source. Recent studies have shown that electrical power outputs of over 550 kWe can be obtained by the use of CBC, SC or PRC power conversion equipment with the SP-100 reactor.

Use of the SP-100 reactor on the Martian surface would require that the reactor and any of the power conversion equipment fabricated from refractory alloys be isolated from the Martian environment.

CONCEPT DESCRIPTION

The SP-100 reactor is coupled to a dynamic power conversion system and the resultant power output attainable is increased to about 550 kWe. This increase is due to the greater power conversion efficiency of the dynamic systems.

For each power system case, a common set of ground rules and assumptions has been used for lunar application. These include the following:

- An intermediate heat exchanger is incorporated in all designs to isolate the primary reactor coolant (lithium) from a secondary loop that contained the cycle working fluid (will facilitate maintenance including removal and replacement of the power conversion units);
- auxiliary power is available for thaw and startup;
- a vacuum/guard vessel is provided as part of the system;
- a passive cooling system transports waste heat from all sources to the planetary or lunar surface, where the heat is rejected to space by a radiator;
- a free convection loop is provided to remove decay heat if required;
- an expansion tank with a free surface is provided to accommodate both lithium expansion and helium gas generation in the reactor;
- all power conversion equipment, reactor control actuators and heat rejection equipment is located at grade level to provide for maintainability; and
- a voltage output of 1000 Vac or dc.

The reactor designed for the SP-100 system is a fast spectrum design with sealed uranium nitride (UN) fuel pins contained in a single vessel with liquid lithium circulated as the coolant. The reactor is approximately 0.55 meters in diameter by 0.75 meters high. Twelve sliding blocks in the radial reflector assembly open to allow neutron leakage from the core, which provides reactivity control. PWC-11 refractory metal is used for the reactor fuel pin cladding and for the reactor structure. Three safety rods are inserted into the reactor core during launch and ascent and are extracted only after a nuclear safe orbit is achieved. The reactor is nominally rated at 2.4 MWt and delivers its thermal energy to liquid lithium at 1350°K.

Shielding for planetary applications may be configured to maximize the use of indigenous materials. Alternatively, where deployment time and effort must be minimized, a 4T shield would be integral with the reactor system.

The flow schematic and nominal operating state points for the Brayton system are shown in Figure H-1. A single lithium primary loop transports heat from the reactor to the primary heat exchanger. The Brayton cycle uses a helium-xenon gas mixture for the working fluid. Heat is rejected from the cycle through a NaK heat rejection loop. Each Brayton loop is cross coupled to each of the four radiator panels so that if a power conversion system failure occurs there is no loss of radiator area. The NaK loop is also used to cool the alternator. The Brayton turbine uses a single stage radial inflow design and the compressor uses a single-stage radial outflow design. The turbine wheel, alternator and compressor are all mounted on a single shaft. Both the journal and thrust bearings use compliant pad gas lubricated foil bearings. Gross cycle efficiency for the Brayton unit was estimated at 25.7%.

The Free-Piston Stirling Engine (FPSE) is a thermally driven mechanical oscillator operating on a Stirling engine cycle which derives power from the heat flow between a heat source and a sink. The desired displacer motion in the FPSE is produced by gas forces rather than kinematic linkages. This engine operates at the highest overall device efficiency of all known heat engines. In addition, the FPSE is uniquely suited to driving direct coupled reciprocating loads, such as linear alternators, in a hermetically sealed configuration and without the need for high pressure shaft seals or contaminating lubricants.

The flow schematic and nominal operating state points for the Stirling system are shown in Figure H-2. A primary and secondary lithium loop are used to transport heat to the Stirling engine heater. Helium is used for the working fluid for the Stirling cycle. Heat is rejected from the Stirling cooler through a NaK heat rejection loop, which is also used to cool the alternator. As with the Brayton system, the heat rejection loops are cross coupled to each radiator panel. The Stirling engine used in this application is an opposed piston design which is selected for its minimal vibration characteristics. The gross cycle efficiency for the Stirling is 33.0%.

DYNAMIC SP-100 POWER SYSTEM TECHNOLOGY ROADMAP

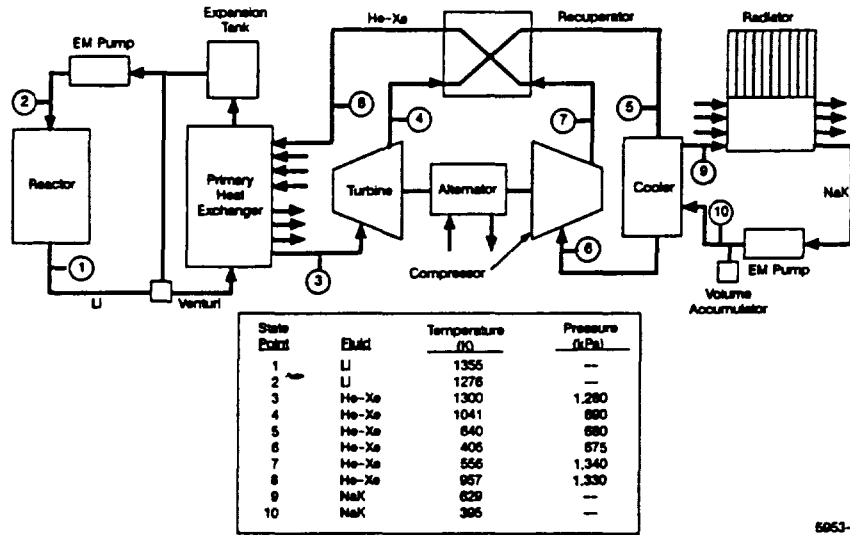

5953-6

Figure H-1. 550 kW Brayton cycle power system schematic.

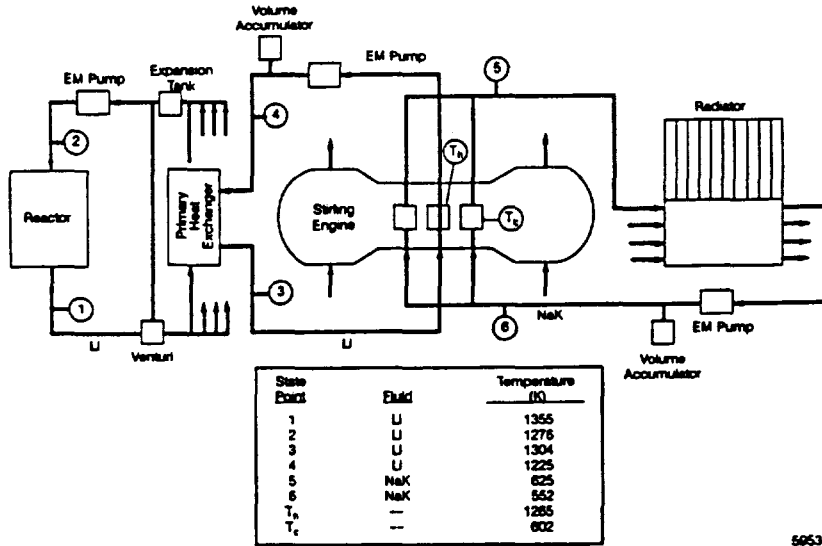

5953-7

Figure H-2. 550 kW Stirling cycle power system schematic.

The flow schematic and nominal operating state points for the potassium Rankine system are shown in Figure H-3. The power system contains a lithium cooled primary loop and a potassium power conversion loop. The primary heat transport loop includes the reactor, potassium boiler, EM-pump, expansion tank, flow control venturi, decay heat removal system, and interconnecting piping. All primary loop components are electrically trace heated to provide for controlled lithium thaw during start-up. The boiler supplies dry saturated potassium vapor to the turbines. The power conversion unit consists of a turbine, alternator and boiler feed pump mounted on a common shaft. Moisture separators are used in the turbine to maintain vapor quality above 89% to minimize turbine erosion. A salient pole alternator is used to minimize mass. The heat rejection subsystem is made up of the main cycle radiator as well as an auxiliary radiator for alternator and bearing coolant. The jet condenser diverts a major portion of the potassium feed from the feed pump outlet to the main radiator manifolds then back to the jet condenser where it is injected. The low pressure turbine exhaust is condensed by the injected liquid potassium and all liquid is collected at the condenser throat.

Cycle efficiency is about 23.3%.

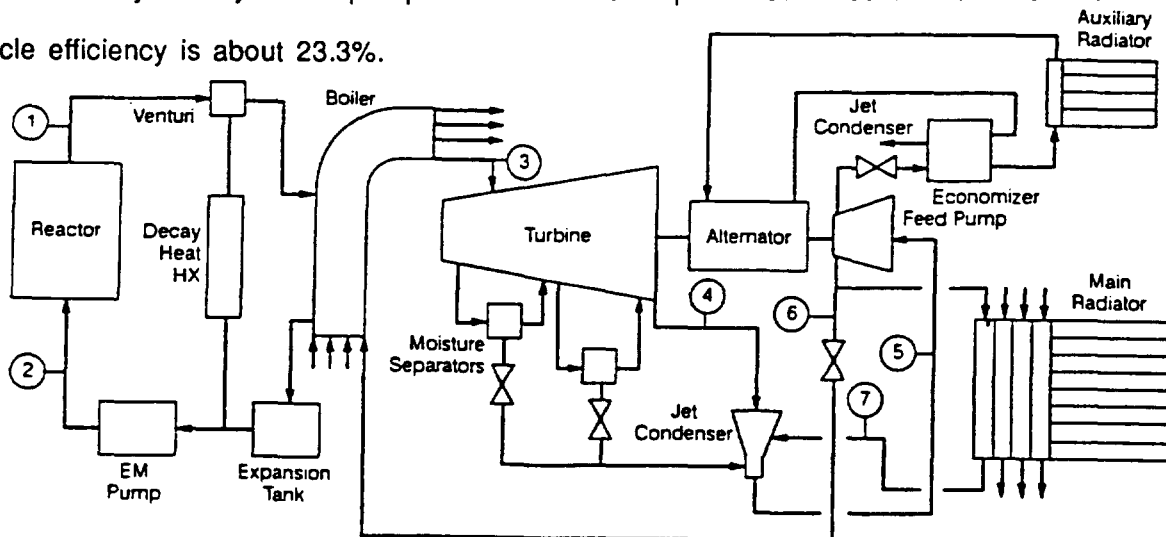

State Point	Fluid	Temperature (K)	Pressure (kPa)
1	Li	1355	-
2	Li	1276	-
3	K	1275	629
4	K	850	13
5	K	844	227
6	K	845	649
7	K	744	611

Figure H-3. Potassium Rankine cycle power system schematic.

The overall deployed arrangements for the 550 kWe lunar surface Stirling, Brayton, and potassium Rankine systems are shown in Figure H-4. The radiators are arranged in a vertical cruciform configuration with the cooling headers located at the bottom of the radiator panels. Because of the small radiator required for the potassium Rankine system, a cruciform configuration was not required. Vertical reflux condenser tubes are connected to the header and reject the waste heat to space. The guard vessel radiators are located between the main radiator panels.

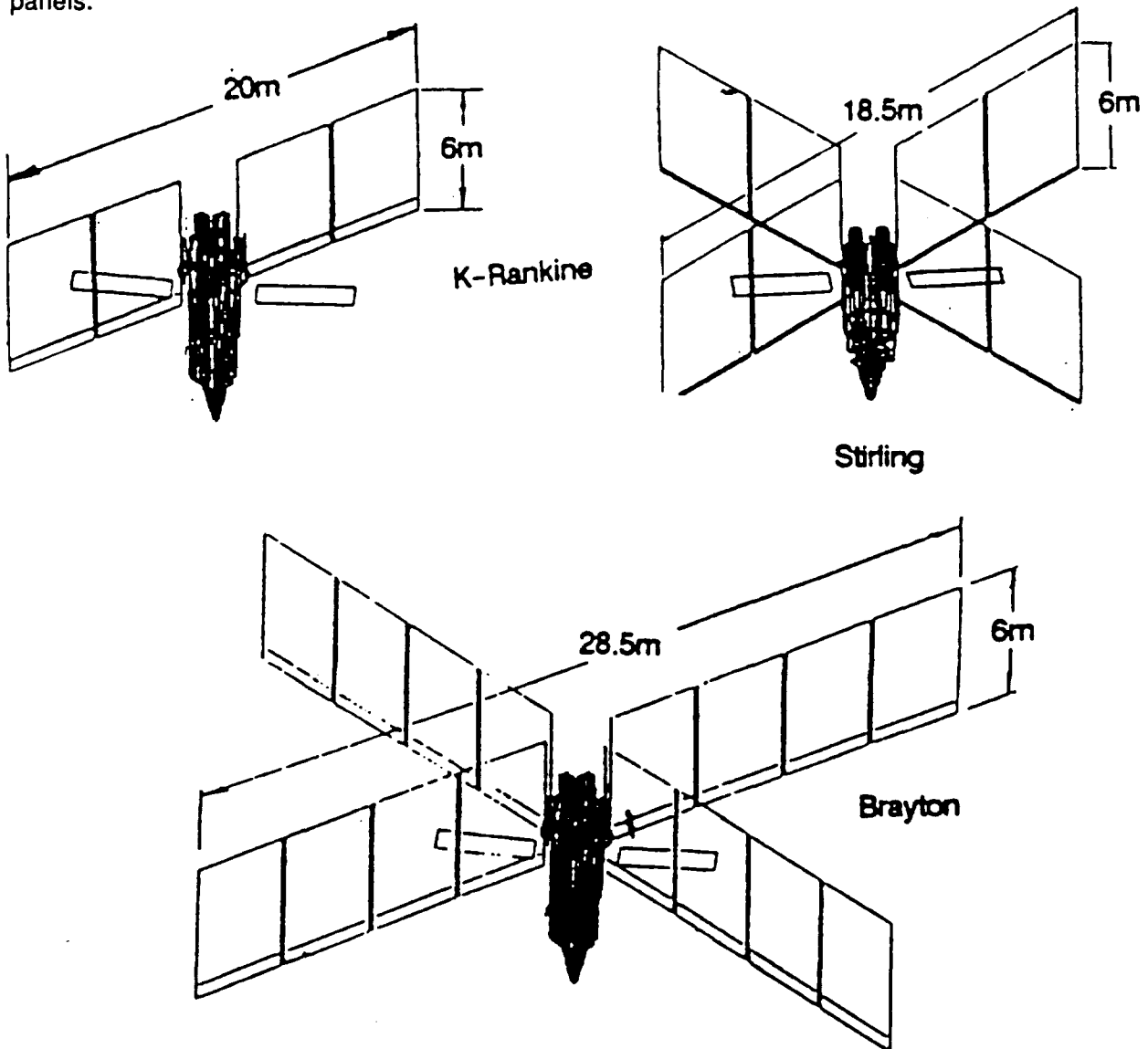

Figure H-4. 550 kWe lunar surface power system configurations.

In each case the entire primary loop is contained within a stainless steel guard vessel. The vessel is closely fitted to the reactor in order to prevent uncovering of the reactor should a breach in the lithium primary loop occur. The vessel is borated in the vicinity of the reactor to minimize the effect on reactor control from back scattered neutrons. The guard vessel is passively cooled by reflux condenser pipes bonded to the outer surface. Heat generated in the vessel is dissipated in a separate radiator located above grade.

In the case of a buried reactor, a regolith shield is located between the primary loop equipment gallery and the power conversion equipment. The shield tank is filled with the local regolith during installation and functions as a shutdown shield. A typical buried power system installation is shown in Figure H-5. The power system is placed in an excavated pit and then back filled. The regolith shield tank is filled with regolith and vibration compacted. The radiator panels are extended and electrical connections are made before the system is ready for startup.

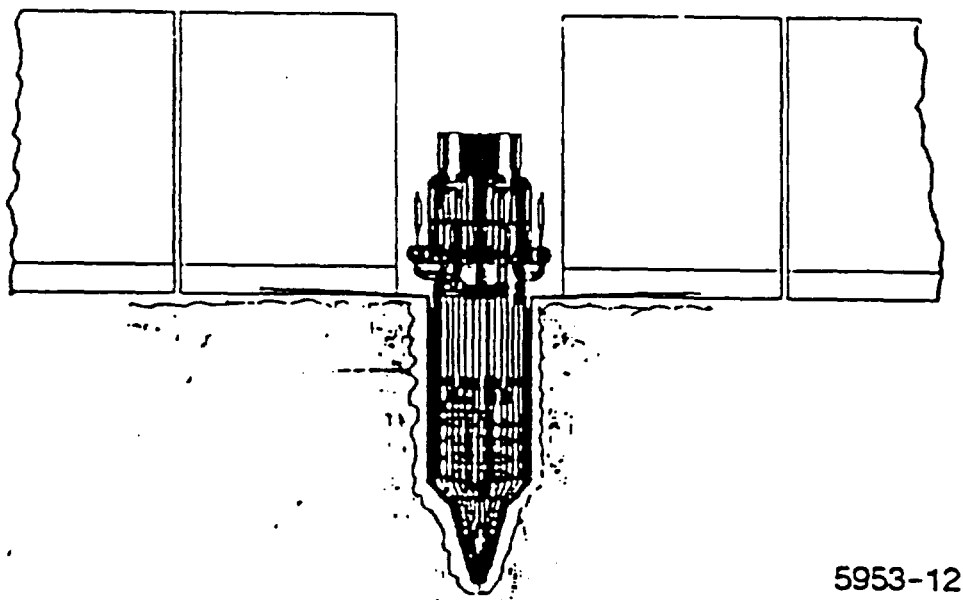

Figure H-5. - Buried 550 kWe lunar surface power system installation.

DYNAMIC SP-100 POWER SYSTEM TECHNOLOGY ROADMAP

Thermal transport (from the reactor to the Power Conversion Unit [PCU] and from the PCU to the radiator) is accomplished by liquid metal coolant that is pumped by electromagnetic (EM) pumps. A pair of supply and return lines feed the liquid to thermopile heat exchanger located in each PCU. The supply and return lines are connected to common supply and return headers located within the reactor subsystem. The EM pump is located between the common return header and the reactor vessel. The liquid metal is in a frozen condition until system startup. Thawout of the frozen lithium lines is accomplished using electrical trace heaters.

Reject heat from the power conversion systems are transported to the radiator panels by a NaK pumped loop. The radiator panels use carbon-carbon heat pipes with potassium as the working fluid and a thin metal niobium liner to prevent contact between the potassium and the carbon-carbon structure.

The power conditioning electronics and shunt dissipators are located on a remote power processing module. The shunt regulator provides voltage regulation on the nominal buss output and is capable of load following without restriction as long as loads do not exceed the power generation capability.

KEY ISSUES

The key systems issues are summarized in Table H-1. Due to prior development of the SP-100 TE system, the development costs and risks should be relatively low for dynamic SP-100 systems.

TABLE H-1. KEY ISSUES, IMPACTS, AND DEVELOPMENT AREAS

Issues	Impacts	Potential Development Areas
Safety of nuclear systems during operation	•Increase in system mass for shielding - may be especially significant if in-situ materials are not used	•Use of in-situ materials for shielding or 4π shield designs
Lunar/Mars Environment	•Refractory metal lifetime •Increased system mass	•Coatings, getters, liners, dust protection

DYNAMIC SP-100 POWER SYSTEM TECHNOLOGY ROADMAP

TECHNOLOGY ASSESSMENT

The technology bases were assessed for the following major Dynamic SP-100 assemblies:

- SP-100 space power reactor;
- power conversion devices;
- radiator; and
- power processing and control system (PP&C).

The current technology readiness of each assembly and the estimated technology readiness at program start (year 2001 or beyond) were evaluated using the NASA technology readiness levels. It was assumed that the SP-100 TE power system and several key components (1300 °K SC PCU, carbon-carbon radiator, PP&C) would be developed to at least level 6 prior to program start. These evaluations are summarized in Table H-2. The technology base for each assembly is briefly discussed in the following sections.

TABLE H-2. DYNAMIC SP-100 TECHNOLOGY ASSESSMENT

Assembly	Current Technology Readiness Levels	Program Start Technology Readiness Levels	Comments
SP-100 Reactor	3	6	Currently funded development program
PCU (1300 °K)	4 / 3 / 3 *	4 / 6 / 3 *	CBC-good previous experience, DIPS; SC-Rapid progress on current NASA programs; PRC-no currently active development; 1300 °K materials proven
Radiator	4 / 3 **	6 (C-C)	Currently under development
PP&C	4	6	SP-100 program; Space Station technology

*Brayton cycle/Stirling cycle/potassium Rankine cycle.

**Metal heat pipe/carbon-carbon heat pipe.

SP-100 Space Reactor State-of-the-Art

The SP-100 power reactor is actively being developed by the General Electric corporation under a joint DOD/DOE/NASA program. Considerable progress has been made in the development of the fuel pins and reactor components.

A fuel pin irradiation testing program has demonstrated the capability of the generic flight system fuel pin to meet performance requirements that call for full power operation to about 6.0 atom percent burnup for seven years. Irradiation tests have included UN fuel pins with Nb-1Zr cladding the W or Re liners, Re liners bonded to Nb-1Zr cladding, and Re cladding. The accelerated tests (fluences and burnup levels are achieved in a fraction of the actual service durations) will provide the information required for formulating the analytical models and validating the fuel pin design.

Nuclear assembly fabrication development was investigated and a process to extrude nozzles in the inlet/outlet nozzle course portion of the reactor vessel. A demonstration nozzle has been formed to the correct dimensions by the extrusion process at room temperature.

Nb-1Zr weld specimens have been exposed to lithium to evaluate the effect of welding atmosphere purity and post weld heat treatment on the sensitivity to lithium attack at grain boundaries. Results of the tests indicate that the welds containing bulk oxygen contents greater than 176 ppm experienced lithium attack at the Nb-1Zr grain boundaries. No attack was observed for bulk oxygen levels less than 140 ppm. The results of this work indicate that if low oxygen levels are maintained during welding, the potential for lithium attack is essentially eliminated.

Nondestructive examination methods continued to be developed and improved with most efforts being concentrated on support of the barrier fuel program. Production techniques for nondestructive testing of bonded fuel tubes were developed. A microfocus rod anode X-ray system was used in conjunction with ultrasonic testing to evaluate the detection of defects in various weld configurations.

A reactor flow test was completed including test article fabrication, test planning, and the completion of a comprehensive series of tests. Results of the test program provide important fuel assembly hydraulic design correlations as well as a validated orifice sizing procedure. The technology readiness level of the SP-100 reactor assembly is judged to be at level 3. Sufficient background work has been done to enable the fabrication and testing of a breadboard model to be started.

Potassium Rankine PCU State-of-the-Art.

In the 1960s, a large amount of work was done on Rankine PCSs for space power that used potassium for the working fluid. By 1970, the level of work had been greatly reduced. In terms of high temperature test hours, the largest contributors to boiling potassium research and development were AirResearch, General Electric, ORNL and Pratt & Whitney.

Table H-3 lists these organizations and summarizes the hours of operation on various systems and components for both potassium and cesium. Subtotals for the boiling corrosion subsystems, component test boiling subsystems, simulated Rankine cycle power plant subsystems, and the total operating time for all boiling subsystems are presented. The dimensions of all the components in the simulated subsystems were proportioned to provide operating characteristics and responses similar to those expected in the operation of a Rankine cycle space power plant. This is the major distinguishing feature between the simulated and the component test boiling subsystems. The total operating time for each component operated in these subsystems is also provided. Note that the total amount of operating experience at each installation is smaller than the sum of the operating concurrently for all of the components because two or more components were operated in each subsystem.

The major attraction of the potassium Rankine PCS is that it is compatible with higher source temperatures. This potential provides the higher Carnot efficiency and higher overall efficiency since the device efficiency can be expected to be about 40% of Carnot.

DYNAMIC SP-100 POWER SYSTEM TECHNOLOGY ROADMAP

Several potassium Rankine system conceptual designs exist but none have progressed beyond the drawing board stage. The technology rating of potassium Rankine power conversion is judged to be approximately 3.0.

TABLE H-3. OPERATING TIMES WITH POTASSIUM AND CESIUM POWER CONVERSION SUBSYSTEMS AND COMPONENTS AT TEMPERATURES ABOVE 810°K

	Potassium Systems									Cesium Systems			
	ACN ^a	AS ^b	Allison ^c	GE ^d	JPL ^e	NASA ^f	ORNL ^g	P&WA ^h	RD ⁱ	UNO	BNL ^j	ACN ^k	WA ^m
Corrosion Test Systems													
Boiling systems				10,500			43,600	12,000					420
Thermal convection													
Forced convection													
One loop		1,300					14,200				1,100	2,000	
Two loops				5,000			5,000						
Subtotal		1,300		15,500			62,800	12,000			1,100	2,000	420
All liquid systems													
Thermal convection										100,000			
Forced convection			53,000							3,000			
Component Test Systems (Boiling)													
One loop	100	5,000		11,900			2,800	3,600	200			2,500	
Two loops		900		7,700		400		1,300					
Three loops						600							
Subtotal	100	5,900		19,600		1,000	2,800	4,900	200			2,500	
Simulated Power Plant Systems													
One loop							10,200						
Two loops					1,000		1,000						
Subtotal					1,000		10,200						
Total for all boiling systems	100	7,200		35,100	1,000	1,000	75,800	16,900	200		1,100	4,500	420
Component - Power Plant													
Boilers													
<35 kW		1,300			1,000		71,400	16,900					
>35 kW	100	5,900		15,500	1,000	1,000	4,400	200		1,100	4,500	420	
Subtotal	100	7,200		19,600	1,000	1,000	75,800	16,900	200	1,100	4,500	420	
Turbines													
K lubricating bearings, <10 kW		3,000 ⁿ					5,000 ⁿ		100				
K lubricating bearings, >10 kW		50 ⁿ											
Oil lubricating bearings, >10 kW				5,100 ⁿ									
Boiler feed pumps													
Electromagnetic	100	7,200			3,600	1,000	26,900	4,900	200	3,000	1,100	4,500	
Turbine-driven centrifugal				24,600			5,000 ⁿ						
Radiator						600							
Condenser - liquid metal loop						600	5,000						
Condenser - air cooled		5,900		2,500			43,600	4,900	200				
Condenser - radiator (combined)	100	1,300		16,100	1,000	400	27,200	12,000		1,100	4,500	420	
Subtotal	100	7,200		16,500	1,000	1,600	75,800	16,900	200	1,100	4,500	420	
Electrical generator													
Operation in potassium vapor													
External load device		50											
Pumps in all-liquid systems		5,900	53,000		3,600	1,600	6,100	1,300	1,600	3,000			
Potassium seals		3,050 ⁿ		18,600									
Seal test				5,100 ⁿ									
Bearing test rig				300									
Instrumented		3,000 ⁿ							1,600				
Single bearing endurance test		300					4,500						

^aAerjet-General Nucleonics; San Ramon, CA.

^bAllied Signal; Phoenix, AZ and Los Angeles, CA.

^cAllison Division of General Motors; Indianapolis, IN.

^dGeneral Electric Company; Cincinnati, OH.

^eJet Propulsion Laboratory; Pasadena, CA.

^fNational Aeronautics and Space Administration; Cleveland, OH.

^gOak Ridge National Laboratory; Oak Ridge, TN.

^hPratt and Whitney Aircraft (CANEL); Middletown, CT.

ⁱRocketdyne; Canoga Park, CA.

^jUnited Nuclear; White Plains, NY.

^kBrookhaven National Laboratory; Upton, Long Island, NY.

^mWestinghouse Astronuclear; Large, PA.

ⁿThe time shown for boiler feed pump, potassium seal and test bearing was accumulated during operation of the turbine indicated in that column.

Brayton Cycle PCU State-of-the-Art.

The closed cycle gas turbine Brayton PCU is adaptable to a wide range of applications and power levels. Practical competitive systems have been designed and/or built for space, terrestrial, marine, and underwater environments with power levels ranging from 500 watts to more than 500 Megawatts. Input thermal energy can be from solar, nuclear, and fossil or chemical combustion with waste heat rejected to the environment by a wide variety of methods. The major reason for interest in the closed Brayton cycle is its high demonstrated efficiency, simplicity and mature technology. Commercial combined cycle machines have been constructed with overall cycle efficiencies of 50%. Low temperature space power units (e.g., DIPS) have cycle efficiencies in the 20 to 25% range. Selection of the system operating points is usually done on the basis of minimizing system mass while observing sensible design limits for the different components.

During the late 1960s and 1970s, NASA conducted several near-prototypical development programs using Brayton rotating machinery and accessories. These included the Mini-BRU, the CRU and the BRU. Four "B" engines were built using BRUs with 1144 °K TIT capability were developed under NASA contract by Garrett Corporation (now Allied Signal) and sent to NASA LeRC for performance and endurance testing. The purpose of these tests was to demonstrate the technology for space application of the closed-cycle Brayton engine. One of these engines accumulated 38,000 hrs of successful operation, while achieving cycle efficiencies of 30 to 33%. The two units tested met or exceeded performance objectives with no detectable performance degradation during endurance testing.

Although low temperature CBC PCUs are well developed (TRL of 5), high temperature CBC PCUs are yet to be built. Existing refractory-metal alloys are available that will be suitable for high temperature operation (though they must be protected from the Martian environment). PWC-11 (Nb-1Zr-0.1C) is now being exploited under the SP-100 program (Ref. H-1). JPL and Los Alamos National Laboratory will operate PWC-11 as reactor-fuel clad at 1400 °K. The U.S. has a great deal of experience with Nb-base refractory-metal alloys. This

includes use of Nb-1Zr in the Brayton solar-heat receiver to C-103 (Nb-10Hf-1Ti-0.72r) in both the Heat Source Assembly and the turbine for the Mini-Brayton powerplant. Thus, the 1300 °K CBC PCU was given a technology rating of 4 (Refs. H-1 and H-2).

Stirling Cycle PCU State-of-the-Art.

Major interest for space based power systems has been centered on the free piston Stirling engine (FPSE). The FPSE concept was first invented in the U.S. in 1963. NASA has been sponsoring an extensive test program of several free piston Stirling engines with linear alternators built by Mechanical Technologies Incorporated (MTI). The NASA Stirling Space Power Converter Program originated in 1984 as part of the SP-100 program. A summary of the test times accumulated on these engines is given in Table H-4. One engine, the EM-2 has accumulated over 5000 hrs in tests at MTI.

The currently funded NASA FPSE program will result in a space capable 1050 °K FPSE by 1996 (Ref. H-3). The ultimate goal of the space FPSE program is to develop the technologies for a refractory metal Stirling power converter with a hot end temperature of 1300 °K and a cold end temperature of 650 °K. The NASA approach is to take the 1050 °K superalloy technology and to evolve into 1300 °K technology by direct substitution of refractory materials. The Materials Division at NASA LeRC has substantial experience in the application of refractory materials and has been developing materials for use in the hot components of the SP-100 reactor. The Materials Division has compiled a list of refractory material candidates as seen in Table H-5. The LeRC ratings for each alloy as to joinability, fabricability, availability, and data were rated by NASA on a scale of 0 to 10 with 10 being the best. A NASA contract with MTI called for the refractory design to be carried through the conceptual design phase during FY'91. Funding for full scale development of the 1300 °K machine will be included under the Exploration Technology Program, scheduled for initiation in 1993 (Ref. H-3).

The success of this technology depends upon supporting research and technology efforts including heat pipes, bearings, refractory metal joining technologies, high efficiency

alternators, life and reliability testing, and predictive methodologies. Based on the FPSE experience base and the NASA plans for the high temperature FPSE, the 1300 °K FPSE is given a technology readiness rating of 3.0 (the 1050 °K machine has a rating of 4.0 per Ref. H-4).

TABLE H-4. FREE PISTON STIRLING ENGINE ACCUMULATED TEST TIMES

Engine	Test Hours
RE-1000	280 (NASA)
EM-2	5385 (MTI)
SPDE	253 (MTI)
SPRE-I	349 (NASA), 74 (MTI)
SPRE-II	333 (MTI)

TABLE H-5. REFRACTORY METAL CANDIDATES FOR 1300 °K STIRLING

Base Material	Alloy Name	Composition (wt%)	Melting Point (°K)	Density (kg/m ³)	Join-ability	Fabric-ability	Alloy Avail-ability	Data Avail-ability
W	W-25Re-HfC	24-26% Re 1% HfC	1380	19,300	5	4	4	3
Ta	ASTAR-811C	8% W 1% Re 1% HfC	3270	16,600	8	8	10	5
Mo	TZM	0.08% Zr 0.5% Ti	2880	10,200	2	8	10	4
	TZC	1.25% Ti 0.1% Zr 0.15% C	2880	10,200	2	6	10	4
Mo/Re	Mo-47.5Re	47.5% Re bal. Mo	2780	15,500	8	6	8	3
Nb	FS-85	11% W 28% Ta 1% Zr	2740	8,600	8	8	5	4
	B-88	27% W 2% HfC	2740	8,600	7	7	4	2
	C-103	10% Hf 1% Ti 0.7% Zr	2740	8,600	10	10	10	7
	PWC-11	1% Zr, 0.1% C	2740	8,600	10	10	10	7
	Nb-1Zr	1% Zr	2740	8,600	10	10	10	8

Radiator State-of-the-Art

Presently, Rocketdyne division of Rockwell International is involved in the development of a carbon-carbon (C-C) or graphite heat pipe radiator panel. Rocketdyne has a NASA contract entitled "SP-100 Advanced Radiator Concepts" which started in 1987 and is part of the CSTI (Civilian Space Technology Initiative) program. This program will be completed in January of 1993. This program involves development of a C-C heat pipe suitable for use in an SP-100 radiator. However, this technology will be suitable for other radiator applications as well including dynamic power systems. The hope is that this program will develop generic technology which can be used for all future space radiators because of its reduced mass compared to metal heat pipe radiators. Carbon-carbon is a new structural material which requires different fabrication techniques than for metals or composites. A key objective of this program is to demonstrate the ability to fabricate C-C heat pipes with a thin metal liner, wicks, caps, and fill tube. The brazing technique required to attach liners is the same as would be required to attach manifolds to the heat pipes. Heat pipes filled with potassium will be designed, fabricated, and tested during this program. Thermal cycle testing will be done in a vacuum to demonstrate the integrity of the heat pipes.

The current technology level of the radiator subsystem is estimated to be about 4 for the metal heat pipe radiators and about 3 for carbon-carbon heat pipe radiators.

PP&C State-of-the-Art

The electronic component technology required for the PP&C equipment is being developed for future power system applications under the SP-100 and Space Station Freedom Electrical Power Subsystem (SSF EPS) programs. Currently available analytical and design technologies will be used along with radiation hardness testing. Radiation hardened high reliability Class S parts will ensure that a reliable and low risk power processing and control system is provided. Rockwell is currently developing the SSF EPS, and this technology is directly transferable to Dynamic SP-100 lunar and Mars surface power systems concepts. The use of multiple buses,

components for the switching of loads, and switching of subassemblies within the power assembly are technologies common to the two programs.

Several active efforts are underway to develop expert system techniques for real-time control applications. These include a design for the evaluation of Space Shuttle Main Engine (SSME) performance, sensors and data processing for fault detection, and the electrical load power allocations in the SSF electrical power subsystem. The algorithms for power scheduling and balancing on the space station are in development. Expert system software for the SSF electrical power subsystem is being developed using the ADA environment. This work includes implementing and evaluating an ADA based inference engine, which will enable an expert system to run on standard microprocessors for SSF applications.

The required technology for the control and data acquisition functions currently exists, and the technology for autonomous control is under active development for Space Station Freedom (SSF), ESSA and other space power programs. The need for radiation hardened components with these capabilities remains to be demonstrated, which results in a technology rating of 4.0 for the PP&C subsystem.

MAJOR DEVELOPMENT TASKS

The technology level of Dynamic SP-100 components is expected to range from 3 to 6 at the beginning of full scale development. Most of the remaining work will be in system integration, qualification, and acceptance testing. The development and testing currently envisioned is briefly described in the following sections.

Task 1. Intermediate Heat Exchanger (Integration of Reactor and PCU)

Objectives: Develop an interface between the heat source and PCU to allow heat transport.

Statement of Work: Develop and test an intermediate heat exchanger for transferring heat from the reactor cooling loop to the PCU.

Task 2. Power Conversion Unit Development

Objectives: Complete development of power conversion devices which meet the desired performance and life requirements.

Statement of Work: The following task descriptions apply, depending on the PCU selected:

Potassium Rankine PCU. A significant amount of the enabling technology for potassium Rankine power conversion exists, but particular components have not been designed in any detail for many years. Test loops, materials specifications and performance parameters for virtually all potassium Rankine power system components will require development.

Brayton Cycle PCU. Develop a 1300 °K refractory alloy heat engine based on the CBC PCU for the Dynamic Isotope Power System.

Task 3. Radiator Integration With PCU

Objectives: Provide a means for removing heat from the PCU and transporting the heat to the main radiator.

Task Description: Design and test a heat exchanger and heat transport loop from the PCU to the radiator panels.

Task 4. Ground Engineering System (GES) Testing

Objectives: Complete the system design. Verify all performance characteristics of the unit in conjunction with subjecting the GES to MIL-STD-1540 acceptance level tests. Verify adequate system life.

Statement of Work: As a cost reduction measure it has been proposed that GES testing be dispensed with and that space reactor power programs proceed to the flight qualification phase after the component development needed to support final design has been completed. Acceptance of this approach by the technical community is not certain as of this writing, therefore, a discussion of GES testing is included as part of the overall development of a space reactor power system.

After assembly, the GES will be pressure and leak checked, as appropriate, a complete electrical check-out will be performed, and all active devices will be checked out to the extent possible.

Performance and thermal vacuum tests will be conducted during a single thermal vacuum test sequence to demonstrate technical capabilities while minimizing program cost. The performance evaluation will consist of the following major activities:

- Check out and refine subsystem assembly procedures;
- check out procedures for loading and filling the reactor coolant subsystem;
- verify operation of ground support equipment (GSE) and interfaces between GSE and the GES;
- check out ground cooling systems as required;
- verify start up capability;
- verify steady state performance characteristics;
- establish effective operating range of the system;
- check out software and verify autonomy (include all operational modes and simulate failure modes);
- simulate normal switchover from one PCU to another;
- simulate failures to trigger PCU switchover; and
- establish system sensitivity to off-normal conditions such as: (1) partial loss of radiator cooling, (2) varying radiator heat removal profile, (3) partial loss of electronic cooling, and (4) temporary losses of heat sink with varying duration.

The MIL-STD-1540 test sequence will integrate acceptance level and design margin tests as appropriate up to qualification levels, to provide a technically sound, minimum cost approach.

When the performance, acceptance, and margin tests are complete, the GES will be refurbished and placed on a multiyear life test. Instrumentation will be installed to provide a comprehensive diagnosis of the "health" of the GES and to monitor for degradation of major assemblies and individual components. The GES will be operated at its nominal operating point, with expected GES variations in power output and environment.

The GES will be disassembled for diagnosis at the end of the life test. Specific areas to be examined will be determined by an analysis of the health monitoring data and from the reliability analysis predictions.

Task 5. Qualification Program

Objectives: A comprehensive performance and dynamic testing program for assemblies and the complete system will provide a formal demonstration that the Dynamic SP-100 system will perform as designed after being subjected to simulated launch conditions. A low-risk approach, incorporating qualification of individual assemblies, followed by qualification of a complete system, termed the qualification unit (QU), characterizes this program.

Statement of Work: The required qualification tests for the assemblies of the Dynamic SP-100 system are those specified in Section 6.4, "Component Qualification Tests", of MIL-STD-1540B. For the QU, the required qualification tests are in Section 6.2, "Space Vehicle Qualification Tests", of MIL-STD-1540B. Qualification will be to launch environmental conditions selected to envelope the probable intensities developed by various launch scenarios.

The overall approach, starts with qualification of assemblies. Qualified production items are then fabricated and assembled into the QU which is then qualified by the rules for space vehicle qualification. This approach minimizes the risk that some assembly of the QU will fail during the qualification test sequence, thereby nullifying the qualification, and requiring backtracking to recover from the failure.

Performance testing at each level will be conducted to verify that each item performs as designed. The qualification item will be similar to the corresponding engineering item and, therefore, performance testing will be less time consuming.

Dynamic testing will be performed per MIL-STD-1540B, to verify capability of the Dynamic SP-100 system to withstand launch loads, including acoustic, pyroshock and vibrational.

The performance and dynamic qualification test sequence for components and assemblies is shown in Figure H-6. Fabrication, assembly, checkout, and testing of the QU will be similar to the corresponding operations for the GES and therefore, will benefit from the experience with the GES. Test facilities for component and assembly qualification testing will be the same as those for the assembly level testing of the EU test program.

When qualification testing is successfully completed, the QU will be partially disassembled, examined, refurbished as required and modified for endurance testing in air, as described for the GES. The unit will be scheduled for life testing for nominally 1-1/2 years as a basis for estimating program costs. The period can be extended if required.

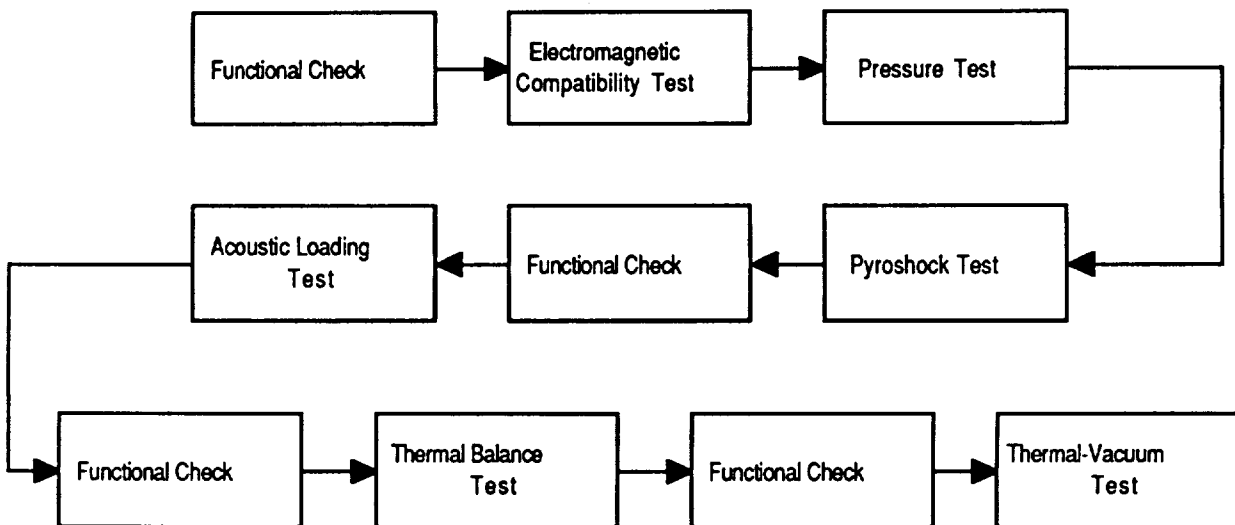

Figure H-6. QU test sequence (per MIL-STD-1540B).

Task 6. Flight System Program

Objectives: Produce, acceptance test, and deliver one or more flight systems.

Statement of Work: In the flight system programs, parts will be fabricated, acceptance tested, and assembled. Systems will be subjected to acceptance testing per MIL-STD-1540B guidelines before shipment to the launch site. The same test facilities (vacuum chamber, vibration, acoustic) that were used for the qualification program would be used for flight system acceptance testing. The flight phase of the program also will include the safety studies and reports necessary to obtain launch approval.

DEVELOPMENT SCHEDULES

The SP-100 program is currently funded but has been experiencing year by year funding reductions, which are resulting in significant schedule slippage. Resolution of the funding question will become more apparent with the identification of a specific mission. A significant amount of development work has been accomplished and the program is considered to be nearly ready to start preliminary design.

Figures H-7 through H-9 present development schedules for the Dynamic SP-100 system with a SC PCU, CBC PCU, and PRC PCU, respectively. This roadmap assumes prior development of the SP-100 TE system, a 1300 °K SC PCU, a carbon-carbon heat pipe radiator, and the PP&C. The different PCU systems will take different development times and will affect the overall system development schedule . The SC Dynamic SP-100 is expected to take the least time (9.5 years) due to prior component development. The potassium Rankine PCU is expected to require three more years (13.5 years) to develop than the CBC PCU (10.5 years). The development times do not include the time to modify the system for use in the Martian environment.

The GES will be similar to a flight system but will have features such as additional instrumentation and readily removable components to expedite gathering of engineering data and to permit modification of components. It will be tested in a vacuum chamber under normal and

DYNAMIC SP-100 POWER SYSTEM TECHNOLOGY ROADMAP

off-normal design conditions. After this phase of testing, it will be partially disassembled, examined, refurbished as necessary, and put on life test, nominally for three years.

The qualification phase includes design, fabrication, assembly, and qualification testing of individual components, and a complete system. The design effort will be minimal since it would involve only minor modifications to the GES design.

The flight phase of the program includes fabrication, assembly, and acceptance testing of the flight units and the associated safety analysis to obtain launch approval.

DYNAMIC SP-100 POWER SYSTEM TECHNOLOGY ROADMAP

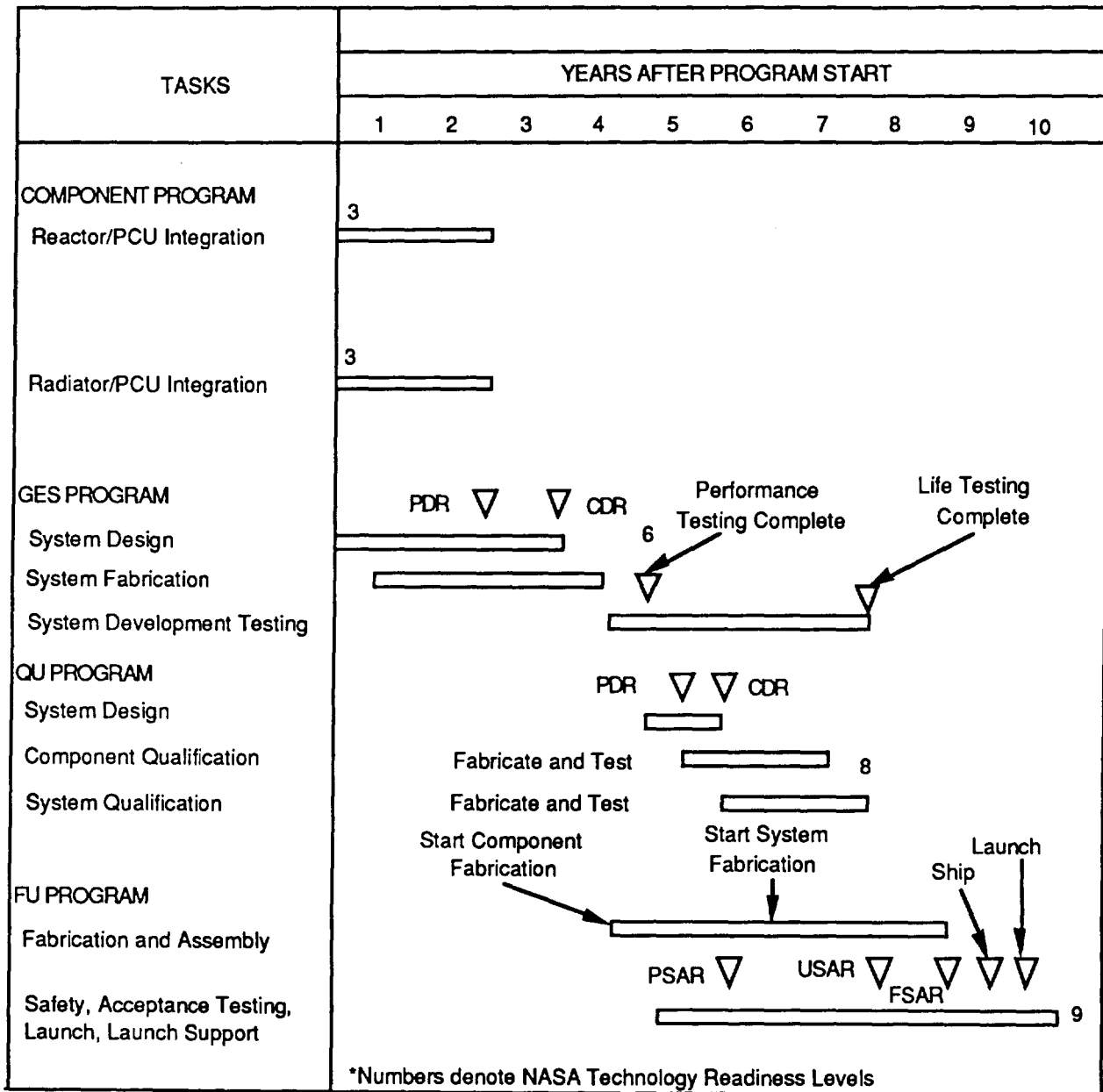

Figure H-7. SC dynamic SP-100 development schedule.

DYNAMIC SP-100 POWER SYSTEM TECHNOLOGY ROADMAP

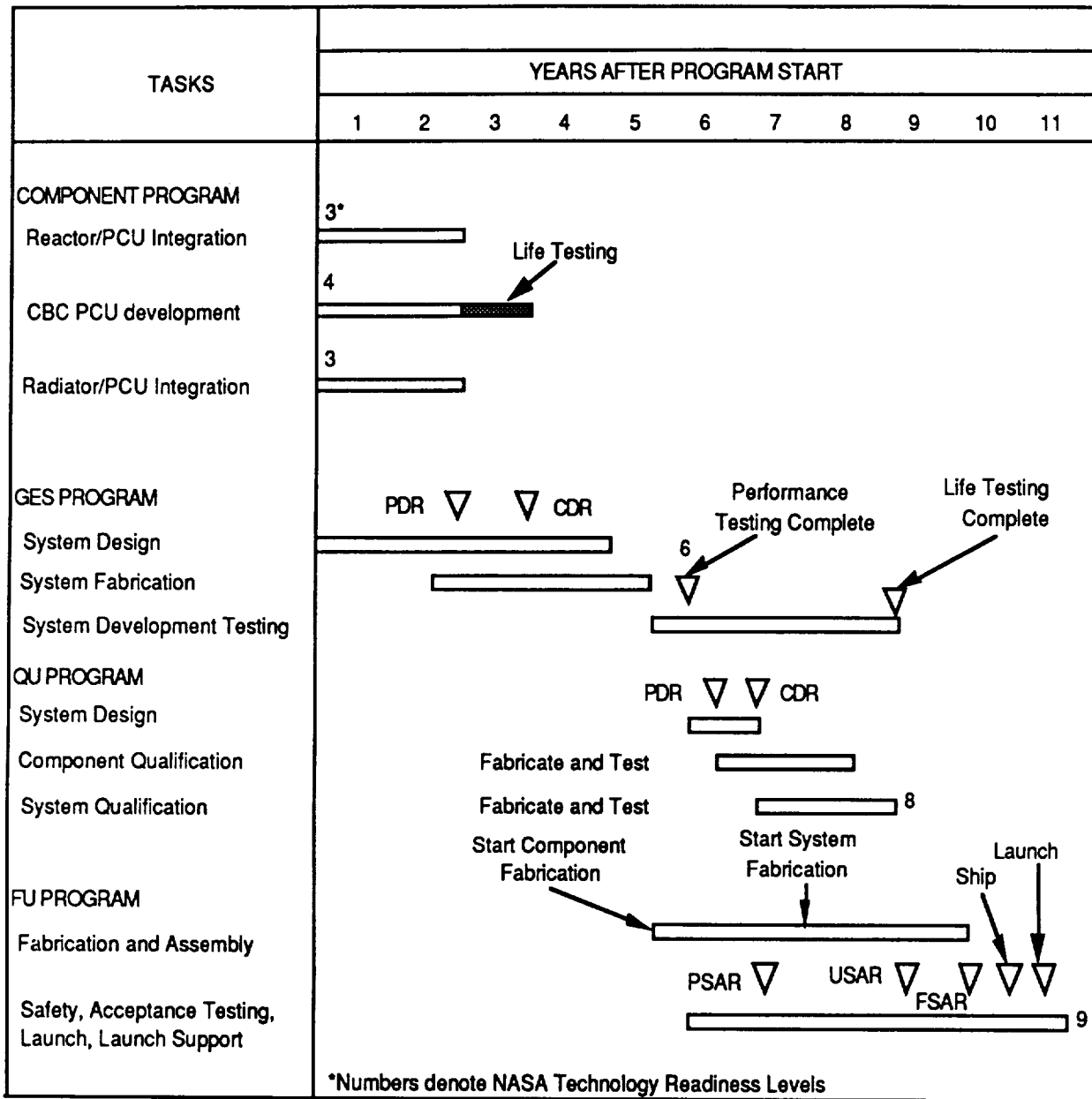

Figure H-8. CBC dynamic SP-100 development schedule.

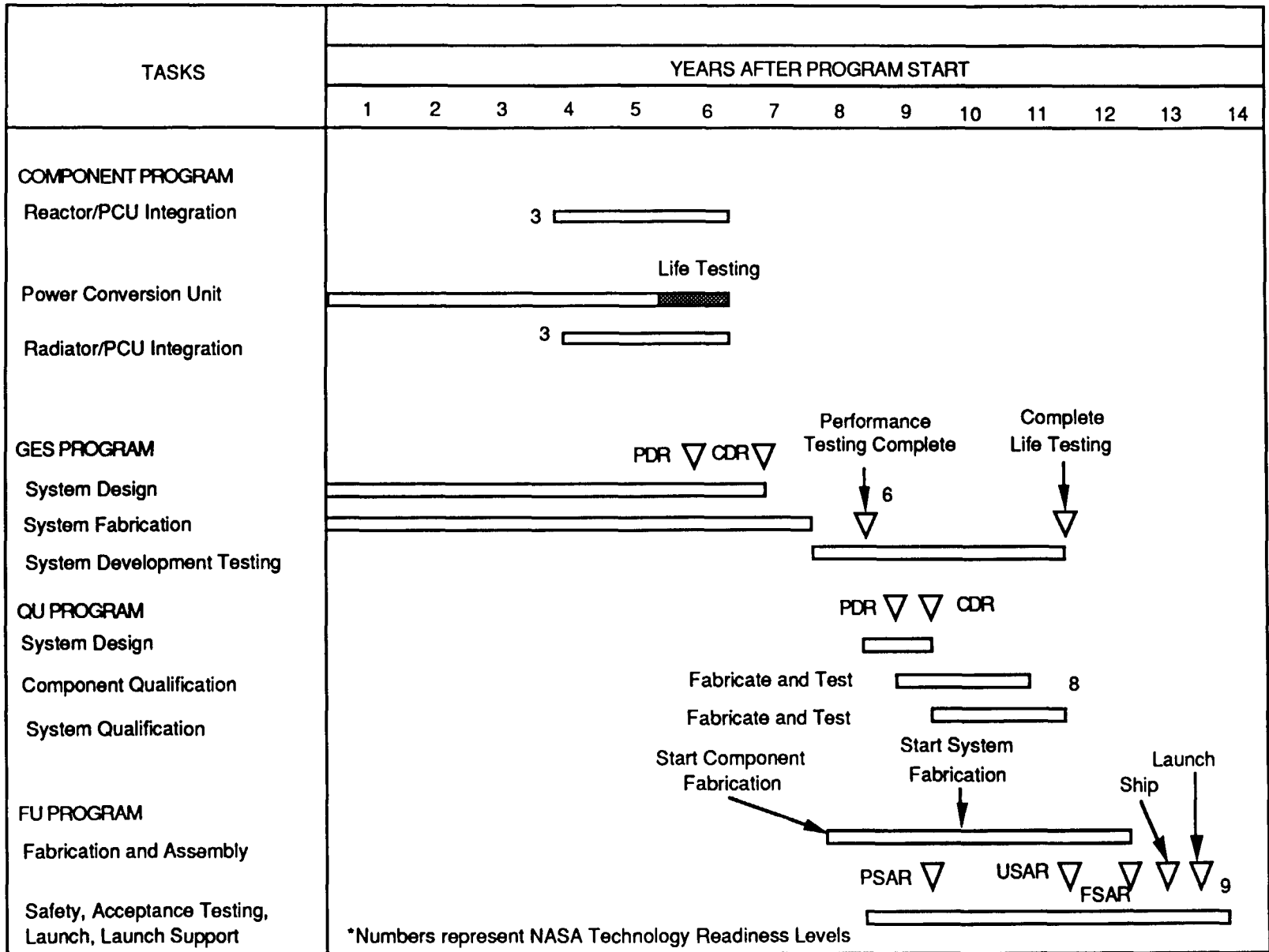

Figure H-9. PRC dynamic SP-100 development schedule.

REFERENCES

- H-1. English, R.: Rockwell Roadmap for Isotope-Brayton (DIPS). Letter to Martin Valgora (NASA LeRC), 4/21/92.
- H-2. English, R.; Mason, L.: Technology Maturation Levels. Personal communications, 3/92.
- H-3. Dudenhoefer, J.E.; and Winter, J.M.: Status of NASA's Stirling Space Program, 26th IECEC Proceedings, Volume 2, 8/91, pp. 38-43.
- H-4. Dudenhoefer, J.E.: Stirling Space Engine Program Status. Personal communication, 3/4/92.