

1994 Fiber Optic Sensors for Aerospace Technology (FOSAT) Workshop

(NASA-CP-10166) THE 1994 FIBER
OPTIC SENSORS FOR AEROSPACE
TECHNOLOGY (FOSAT) WORKSHOP (NASA,
Lewis Research Center) 90 p

N95-24207

Unclas

G3/06 0044623

*Proceedings of a conference held at
NASA Lewis Research Center
Cleveland, Ohio
October 18-20, 1994*

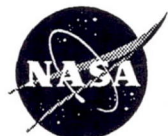

1994 Fiber Optic Sensors for Aerospace Technology (FOSAT) Workshop

*Proceedings of the Conference
held at the NASA Lewis Research Center
sponsored by NASA Lewis Research Center
Cleveland, Ohio
October 18-20, 1994*



National Aeronautics and
Space Administration

Office of Management

**Scientific and Technical
Information Program**

1995

Contents

	Page
List of Acronyms	v <i>omit</i>
Section 1: Overview and Findings	1 <i>omit</i>
Section 2: Presentations to the Plenary Session	
NASA Presentation to the Plenary Session of the FOSAT Robert Baumbick, NASA Lewis Research Center	5 <i>omit</i>
Fiber-Optic Sensors for On-Board Automotive Applications Willes H. Weber, Ford Motor Company	9 -1
Fly-by-Light Commercial Transport Productization John Todd, McDonnell Douglas	13 -2
What BCAG Needs From Fiber Optic Sensors Anthony A. Lambregts, Boeing Commercial Airplane Group	19 -3
Review of Photonic Requirements for Propulsion Controls Chris Fields, Pratt & Whitney	23 -4
Fiber Optics for Propulsion Kiyong Chung, General Electric	29 -5

Section 3: Workshops

Systems Session

Industry Chair: John Todd, McDonnell Douglas
Government Coordinator: Robert Baumbick, NASA Lewis Research Center

Summary of Discussion in Systems Work Element John Todd, McDonnell Douglas	35
Review of Government/Industry Programs in Optical Systems Technology	37

Subsystems Session

Industry Chair: William Spillman, Simmons Precision
Government Coordinator: Grig Adamovsky, NASA Lewis Research Center

What Do We Mean by a Subsystem? William Spillman, Simmons Precision	41
--	----

PRECEDING PAGE BLANK NOT FILMED

Sensors/Actuators Session

Industry Chair: Steve Emo, Allied Signal
Government Coordinators: Glenn Beheim and Margaret Tuma, NASA Lewis Research Center

Minutes From Sensors/Actuators Session
Margaret Tuma, NASA Lewis Research Center55

Fiber Optic Sensors: Issues and Answers?
Raymond W. Huggins and Mahesh C. Reddy, Boeing Aircraft67

Components Session

Industry Chair: Gerard Walles, Sikorsky Aircraft
Government Coordinator: Jorge Sotomayer, NASA Lewis Research Center

Interconnect Requirements for Aerospace Applications
Gerard Walles, Sikorsky Aircraft83

Appendix—List of Attendees89

List of Acronyms

AB	afterburner
ADOCS	Advanced Digital Optical Control System
ARINC 636	commercial databus protocol
ARPA	Advanced Research Projects Agency
ATOPS	Advanced Transport Operating System
BEI	Baldwin Electronics Incorporated
CCD	charge coupled device
CO	carbon monoxide
COTS	Commercial off the shelf
CVG	compressor variable geometry
DAC	Douglas Aircraft Company
DEM	demonstration
DFMA	design for manufacturing and assembly
E/O	electrical to optical conversion
ECU	electronic control unit
EDP	electronic digital processor
EGR	exhaust gas recirculation
ELDEC	company name
EMA	electromechanical actuator
EME	electromagnetics effects
EMI	electromagnetic interference
EMT	electromagnetic tolerance
F.O.	fiber optic
FACT	Fiber Optic Aircraft Closed-loop Test
FADEC	full authority digital electronic control
FBL	fly-by-light
FBW	fly-by-wire
FCC	flight control computer
FCS	flight control system
FDDI	Fiber Distributed Data Interface
FLASH	Fly-by-Light Advanced Systems Hardware
FM	frequency multiplexed
FOCSI	fiber optic control system integration
FOCSS	fiber optic control system sensors
FVG	fan variable geometry
GRD	ground
HC	hydrocarbons
HIRF	high intensity radio frequency
IHPTET	Integrated High Performance Turbine Engine Technology
IVHS	automobile project with Japanese auto maker
LAN	local area network
LED	light emitting diode
LRU	line replaceable unit
LTWT	light weight
LVDT	linear variable differential transformer
MEA	more electric airplane
MEE	more electric engine
NASP	National Aerospace Plane

NH	high speed, rpm
NL	low speed, rpm
NOx	nitrous oxides
NSDG	databus protocols
O/E	optical to electrical conversion
OPMIS	Optical Propulsion Management Interface System
OPT	optical
P	pressure, pounds/square inch
PBW	power-by-wire
PC	printed circuit
PIN	positive-intrinsic-negative diode
RL10	upper stage rocket engine
SOA	state of art
SRA	systems research aircraft
T	temperature, °F or °C
THZ	10 ¹² hertz
VAL	validation
VCSEL	vertical cavity surface emitting laser
VDDN	databus protocols
VEN	variable exhaust nozzle
WDM	wavelength division multiplexing

OVERVIEW AND FINDINGS

Overview

The NASA Lewis Research Center conducted a workshop on fiber optic sensor technology for aerospace, land, and sea applications on October 18-20, 1994. However, those in attendance represented only aerospace companies and one land transportation company. The workshop was held at the NASA Lewis Research Center.

The objective of the workshop was to discuss the status and the future direction of fiber optics and optical sensor research. Future research, especially with limited resources, will require a new way of doing business and more cooperation between Government and industry. This cooperation will greatly benefit U.S. companies, enabling them to effectively compete in the global marketplace. To help determine the direction for future Government research in this technology area, representatives of industries (who would likely incorporate this technology into their products) presented their views on future sensor needs. These needs were discussed by the attendees of the workshop.

The workshop was partitioned into four sections: (1) Systems, which considered the integration of all the subsystems into a large operating system, and also addressed the commonality of hardware for commercial or military use and other technology issues such as installation, maintenance, testing, and troubleshooting of installed optical systems; (2) Subsystems, which considered optical feed-forward actuator control circuits, optical sensing circuits, centralized/distributed optical circuits, and integrated optical circuits; (3) Sensors/actuators, which considered passive optical sensors, and distributed, multiparameter, embedded, optically powered, and integrated optical sensors; and (4) Components, which considered connectors (including backplane), optical fibers/harnesses, and E/O and O/E interfaces. Each section was chaired by an industry representative, with a Government person serving as coordinator.

Findings From the Workshop

The participants agreed that acceptance of photonic and fiber optic technology into aerospace products required a focused effort by Government and industry. Specifically, the areas that need special attention are standardization, reliability, cost, supportability, and maintainability.

The Systems Group agreed that a joint Government-industry steering committee was needed to coordinate development activities and technology transfer, thereby eliminating barriers in these areas. Furthermore, they thought the benefits of the technology need to be quantified and the user benefits marketed aggressively. If the technology benefits were quantified and sold to the end user, then internal management at the various companies would more eagerly support research and development of the technology within their companies.

Fiber optics technology can reduce overall costs in a number of ways. The attributes of fiber optics and optical sensor systems that can lead to a lower cost aircraft need to be considered together. For example, weight and volume can be significantly reduced when fiber optic harnesses are used in place of electrical wire. A clean paper design with fiber optics can improve aircraft architecture and can also result in lower costs because wavelength diversity offers an additional degree of freedom for multiplexing. The fact that optical fibers provide no threat of short circuits or sparking can improve the safety of the aircraft and, over the life of the aircraft, also reduce the maintenance costs normally associated with degradation of wire insulation. The electromagnetic immunity of optical fibers also offers the potential for reducing certification costs by using box level certification instead of whole aircraft certification. In future programs, research and development efforts ought to flow from the top down. That is to say, let system definition dictate the efforts expended by the subsystem and components community instead of continuing to spend resources on components and attempting to drive system design from the bottom up.

The most frequently heard comment concerned the transfer of fiber optic technology into aerospace products. The view held by some attendees was that Government programs were not well coordinated and the

technology wasn't being transferred to a broad enough segment of the industrial community. Since the focus currently is on global competition, they thought the Government should act as a catalyst to bring competitors together and concentrate on methods to more effectively transfer the technology on a timely basis. Program coordination would ensure that the experience and hardware developed in one program would be considered for use in other programs involving the same technology. Workshop participants agreed that systems should be defined first, and component requirements should filter down.

The Subsystems Group cited some technology areas where attention needs to be focused. These areas include standardization, improved multiplexing, high accuracy pressure sensors, optical connectors, and distributed optical systems. This group also suggested that, to make the most effective use of scarce resources, there needs to be more collaboration between Government and industry and between competitors. One of the recommendations from this group was the development of an "all optical" test vehicle to be used as a low-cost testbed.

Comments made by the Sensors/Actuators Group emphasized that only aerospace systems should be considered initially, and technology spinoffs would find their way into other markets. They, too, thought that NASA needs to promote technology more effectively and should continue to support and utilize small businesses. A question from this group concerned how to effectively sell fiber optics and photonic technology to internal management.

Specific comments from the Components Group included a request that Government assist industry to more effectively compete in the global marketplace. This group identified key issues that the technology needs to address and provided suggestions for improving existing connectors: Research programs should have interconnects as a line item, and a systems approach should be used for interconnects. They also thought a fiber optic aerospace interconnect council should be established and that, in the area of interconnects, 80 percent of the resources should be earmarked for development, with these programs having short-term vision. Again here, as with the other groups, technology transfer and utilization were considered to be key issues.

A criticism of the NASA FOSAT Workshop was that it was not structured enough and that the people in each group were too narrowly focused, having an interest only in their particular group. It was suggested that a member from each of the subgroups should have attended each of the other subgroups' meetings to bring a broader perspective to the issues being discussed.

Systems people must define architectures for aerospace vehicles and let the requirements flow down to the systems, sensors, actuators, components, and interconnects.

PRESENTATIONS TO THE PLENARY SESSION

Robert Baumbick, NASA Lewis Research Center

Willes H. Weber, Ford Motor

John Todd, McDonnell Douglas

Tony Lambregts, Boeing Commercial

Chris Fields, Pratt-Whitney

Kiyong Chung, General Electric

NASA Presentation to the Plenary Session of the FOSAT

Presenter: Robert Baumbick, NASA Lewis Research Center

1994 FIBER OPTIC SENSORS FOR AEROSPACE TECHNOLOGY WORKSHOP

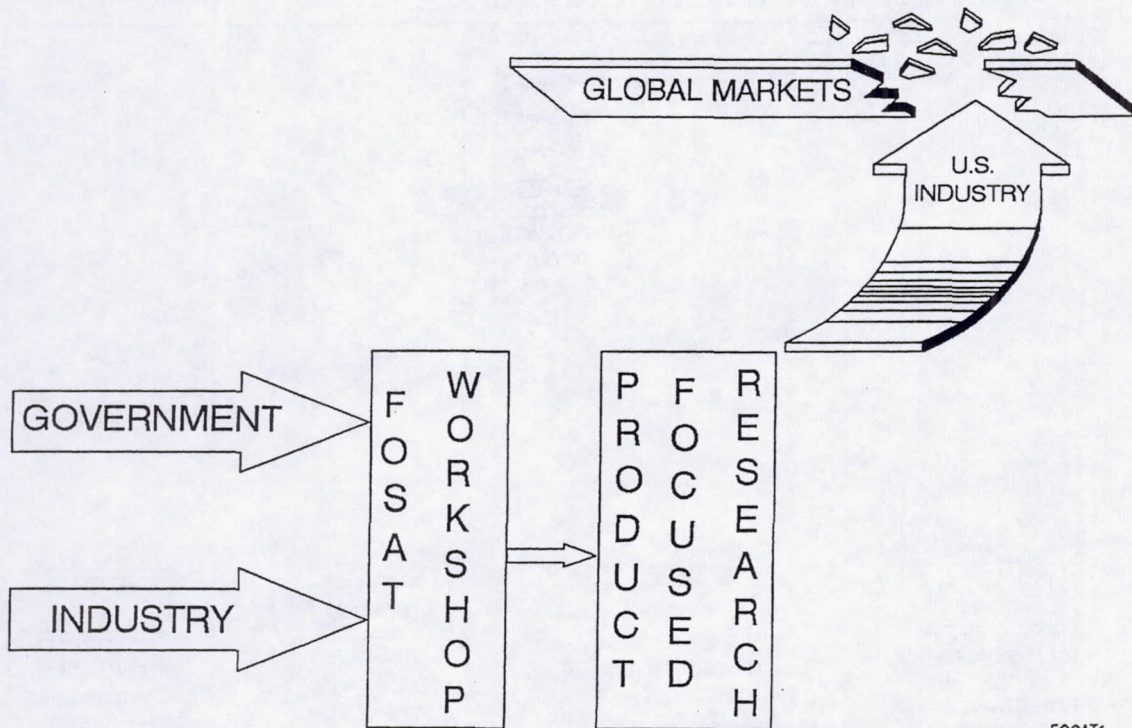

FOSAT1

PRECEDING PAGE BLANK NOT FILMED

FIBER OPTIC SENSORS FOR AEROSPACE TECHNOLOGY (FOSAT)

1994 WORKSHOP

OBJECTIVE: DEVELOP CONSENSUS ON RESEARCH DIRECTION AND
DEFINE RELATIONSHIP BETWEEN GOVERNMENT,
INDUSTRY

ISSUES FOR CONSIDERATION

DEFINE THE GOAL? WHAT NEEDS TO BE DONE TO REACH GOAL?

DEFINE THE MOTIVATOR FOR THE WORK.

WHERE ARE THE HOTBEDS OF ACTIVITY IN THE TECHNOLOGY AREA?

WITH THE LIMITED RESOURCES AVAILABLE WHAT SHOULD THE GOVERNMENTS ROLE BE?

SHOULD INDUSTRY/INDUSTRY OR INDUSTRY/UNIVERSITY CONSORTIA BE FORMED TO FOCUS RESEARCH TOWARD THE END PRODUCT?

HOW CAN INDUSTRY WORK TOGETHER TO IMPROVE U.S. COMPETITIVENESS

WHAT IS THE ROLE OF UNIVERSITIES IN THIS PRODUCT ORIENTED RESEARCH?

1994 FIBER OPTIC SENSORS FOR AEROSPACE TECHNOLOGY WORKSHOP

SYSTEMS WORKSHOP ELEMENT

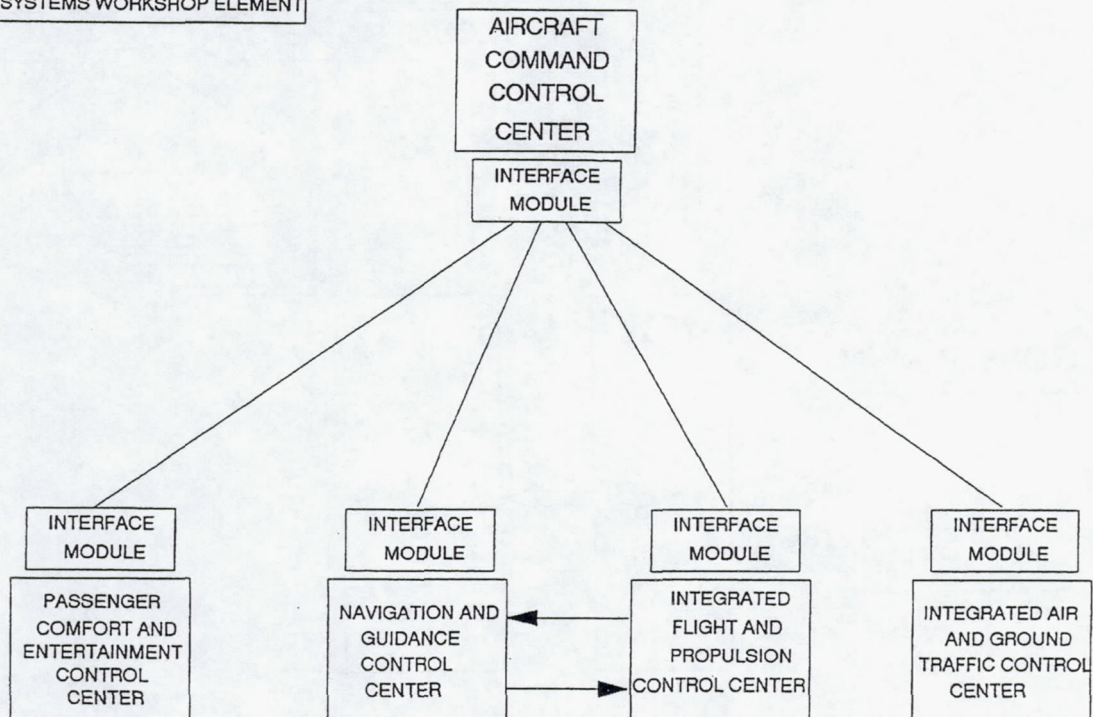

FOSAT2

1994 FIBER OPTIC SENSORS FOR AEROSPACE TECHNOLOGY WORKSHOP

SUBSYSTEMS WORKSHOP ELEMENT

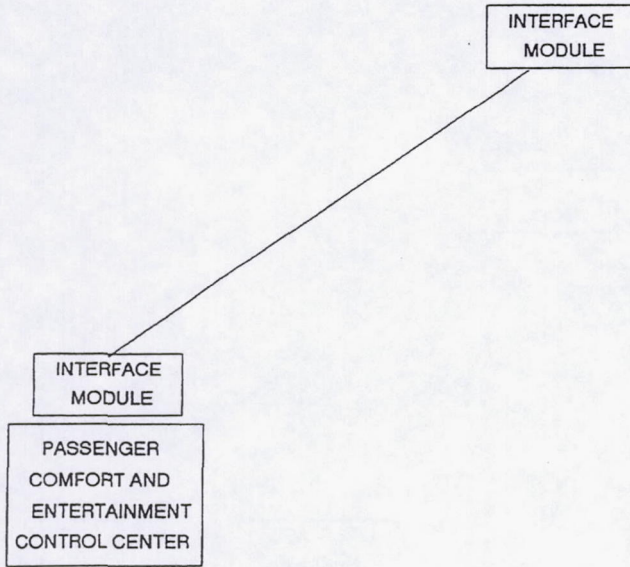

FOSAT3

1994 FIBER OPTIC SENSORS FOR AEROSPACE TECHNOLOGY WORKSHOP

SENSORS/ACTUATORS WORKSHOP ELEMENT

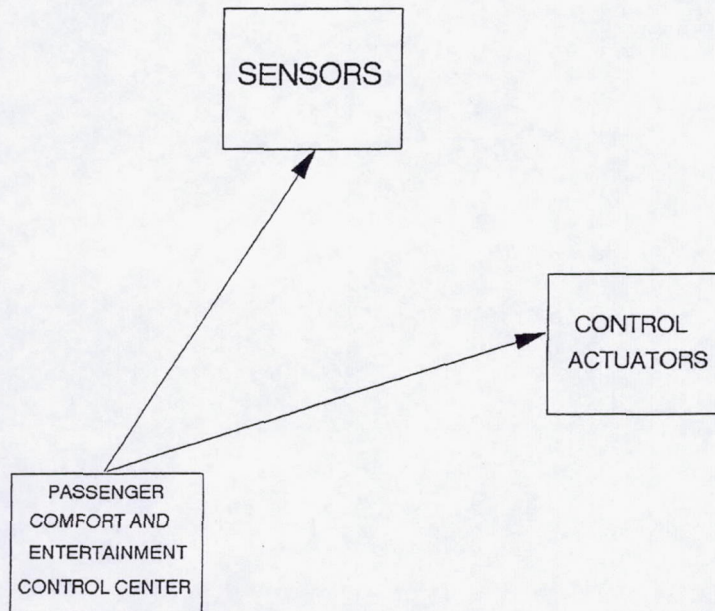

FOSAT4

1994 FIBER OPTIC SENSORS FOR AEROSPACE TECHNOLOGY WORKSHOP

COMPONENTS WORKSHOP ELEMENT

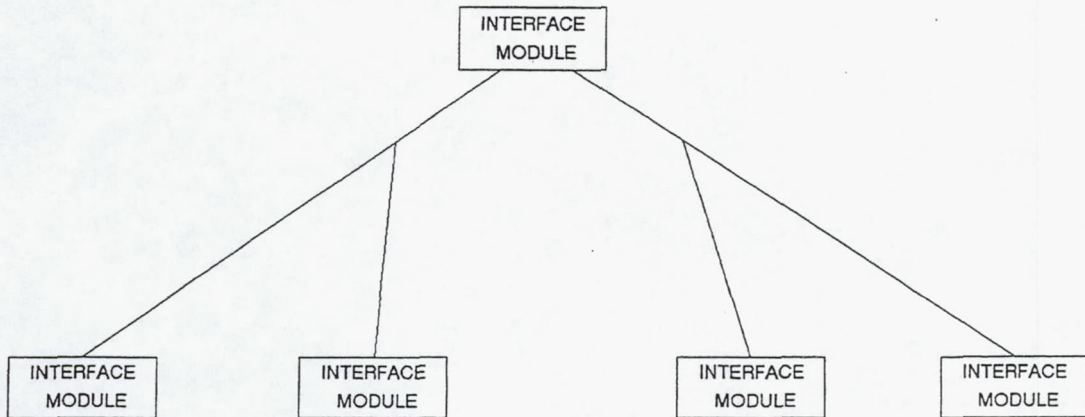

FOSAT5

Fiber-Optic Sensors for On-Board Automotive Applications

1994 FOSAT Workshop

Willes H. Weber – Ford Motor Company

Outline:

- General System/Device Requirements
 - Reliability
 - Cost
 - Interface
 - Environmentally Robust
- Sensor Types, Priorities, and Examples
 - Physical
 - Chemical
- Why are there so few (none) on automobiles now?

Physical Sensors

- Fiber-optic sensors (FOS) have been demonstrated that measure static quantities such as pressure, temperature, position, and composition as well as dynamic variables such as flow rate, speed, and both linear and angular accelerations.
- Most duplicate functions already provided by electrical or electro-mechanical devices already used, without adding significant benefits.
- New FOS's must provide greatly improved functionality. Alternatively, they could be networked with a common light source and multiple detectors to measure many different parameters.
- FO gyroscopes are an example of improved functionality. These are simpler, more reliable, and less expensive than electro-mechanical gyroscopes. They were recently deployed in a fleet of test cars for an experimental IVHS project in the Tokyo area.
- An example of the network approach is a timing-based short-pulse ranging system.

An On-Board, Timing-Based, Networked, Laser Ranging System

- Needs compact, reliable, and inexpensive laser sources that will emit psec-width pulses at repetition rates in the kHz range with a average power exceeding 10 mW.
- The source would likely operate in the red or near-ir region and it might be a diode-pumped mode-locked fiber laser system or a pulsed laser-diode with a fiber amplifier and/or compressor.
- For timing the pulses fast detectors are needed that can measure pulse arrival times with psec resolution. This resolution will give position information accurate to ~ 0.3 mm. The devices must be easily interfaced with Si microprocessors.
- There are many places where position sensing is useful:
 - throttle position
 - EGR valve position
 - gas-cap placement
 - passenger position in air-bag equipped car
 - fuel or brake-fluid level

Chemical Sensors

- The biggest challenge in sensors facing the automobile industry today comes as a result of legislation passed in California referred to as OBD-II. Some of the implications of these laws, which now apply in California and will likely be nationwide in two more years, are summarized in Table 1.

Table 1. OBD-II Requirements

Condition	Requirement
Catalyst Efficiency	Monitor HC emissions. Future laws may demand NO _x and CO monitoring and lower sensitivity.
Misfire	Monitor all cylinders, identifying misfiring one
Evaporative-purge	Monitor all flows from evaporative-purge canister
Fuel-supply system	Monitor compliance to emissions standards
EGR	Monitor gas flows through EGR valve

Possible approaches to optical-based chemical sensors:

- Coat the end of an optical fiber with a material whose fluorescence strength, spectrum, or lifetime is changed by the presence of particular molecular species in the gas stream to which it is exposed.
- Use tunable semiconductor laser to obtain spectrum of exhaust gas. Transport beam to and from hot exhaust with an optical fiber.
- Nondispersive infrared (NDIR), which uses a broadband light source with narrow-pass filters to isolate parts of the spectrum where particular species absorb.
- Use THz radiation generated using all-electronic ultrafast technology to obtain pure rotation spectra of specific molecules.

General Requirements

- Must operate for 100-150k miles/ 8-10 years, ideally with little or no maintenance.
- Cost depends on benefit, but it must be competitive with alternative technologies. New technology is usually introduced on high-end vehicles where cost reduction is not as important. Typically a few \$/device and \$100-\$200 for a system with multiple functions.
- Must be powered off 12 V dc and the output signals must be easily interfaced to Si-based microprocessors.
- Must demonstrate environmentally robust operation: operate in temperatures -40 to 80°C and humidity 10-100%; show immunity to electromagnetic interference, vibration, etc. Sensors on the engine or exhaust must withstand higher temperatures and more corrosive environments.
- A fiber-optic sensor in which the light exits the fiber and then is measured must have some way to keep the window clean to avoid long-term degradation.

3-25-80

Fly-by-Light Commercial Transport Productization

Presentor: John Todd, McDonnell Douglas

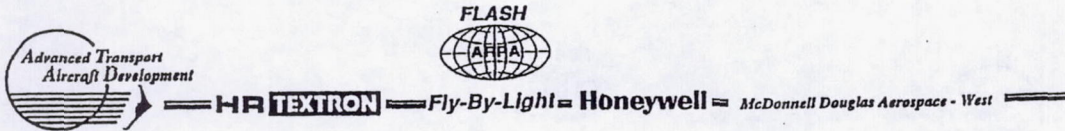

FBL COMMERCIAL TRANSPORT PRODUCTIZATION

<u>AIRCRAFT</u>	<u>INITIAL APPLICATIONS</u>	<u>RETROFIT</u>
MD-95	AILERON TRIM INITIALLY FOLLOWED BY: ENGINE CONTROL (THROTTLES/FADEC), SPOILERS, ELEVATORS, RUDDER, AILERONS, COCKPIT CONTROLS	MD-90, MD-80, DC9 MD-90 MD-90, MD-80 MD-90 MD-90 NONE MD-90 (limited)
MD-11	SLATS INITIALLY ENGINE CONTROLS (THROTTLES/FADEC) COCKPIT CONTROLS AND DISPLAYS (limited) PASSENGER ENTERTAINMENT SYSTEM ELECTRONIC LIBRARY SYSTEM	MD-11 MD-11 MD-11 MD-11,DC-10 MD-11

PRECEDING PAGE BLANK NOT FILMED



HR **TEXTRON**

Fly-By-Light

Honeywell

McDonnell Douglas Aerospace - West

FBL COMMERCIAL TRANSPORT PRODUCTIZATION

<u>AIRCRAFT</u>	<u>INITIAL APPLICATIONS</u>	<u>RETROFIT</u>
MD-12	ALL FLIGHT SURFACES ENGINE CONTROLS (THROTTLES/FADEC) COCKPIT CONTROLS AND DISPLAYS COCKPIT INTERFACE SYSTEM/DATA DIST. LANDING GEAR/NOSE WHEEL STEERING UTILITY SYSTEMS	NONE MD-90,MD-11 NONE NONE MD-95 TBD
C-17	ALL FLIGHT SURFACES ENGINE CONTROLS/THROTTLES COCKPIT CONTROLS AND DISPLAYS HIGH SPEED MISSION AVIONICS DATA BUS LANDING GEAR/NOSE WHEEL STEERING UTILITY SYSTEMS	C-17A C-17A C-17A C-17A C-17A,MD-12 TBD



Fly-By-Light

McDonnell Douglas Aerospace - West

FLY-BY-LIGHT FLIGHT CONTROLS

COMMERCIAL

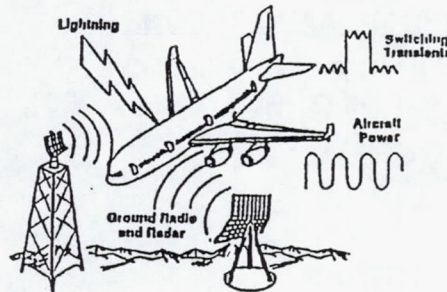

MILITARY

SPACE

FLY-BY-LIGHT SYSTEMS PROVIDE:

- Highest Level of Electromagnetic Noise Resistance Against:
 - High Intensity Radiated Frequency (HIRF)
 - Electric Actuator Transients
 - High Power Microwave (HPM)
 - Electromagnetic Pulse (EMP)
- Weight Savings
 - Over 30% Reduction Over Conventional Controls
- Cost Savings
 - Electromagnetic Interference (EMI) Qualification at the Box Versus Aircraft Level
 - Reduced Maintenance to Retain Shielding Integrity



Fly-By-Light

McDonnell Douglas Aerospace - West

COMMERCIAL FLY-BY-LIGHT VALUE (WIDEBODY EXAMPLE)

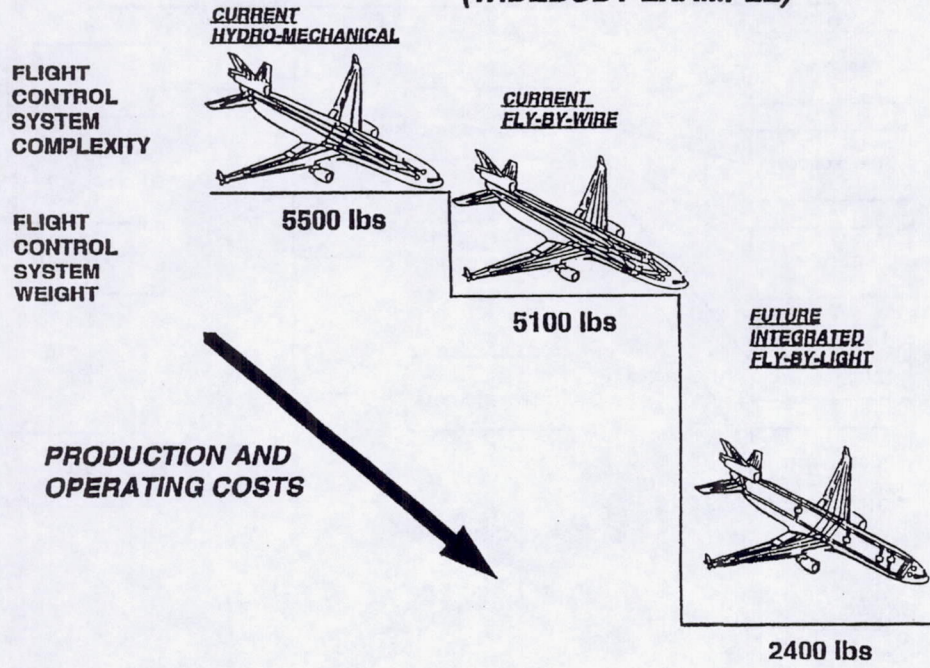

TRANSPORT AIRCRAFT REQUIREMENTS LEVEL APPLICABILITY

	AIRCRAFT	TECHNOLOGY	SYSTEM	SUBSYSTEM	COMPONENT
MISSION					
COST					
SAFETY					
CERTIFICATION					
R/M/S					
PERFORMANCE					
OPERATIONAL					
ENVIRONMENTAL					
DUAL USE					

TRANSPORT AIRCRAFT DUAL USE REQUIREMENTS FLOW

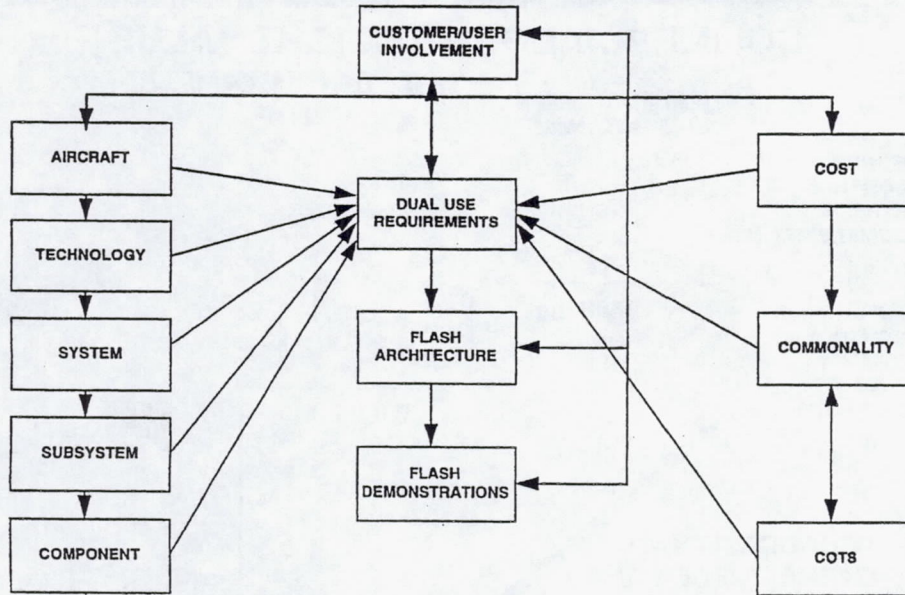

TOP LEVEL AIRCRAFT TYPE REQUIREMENTS BREAKDOWN

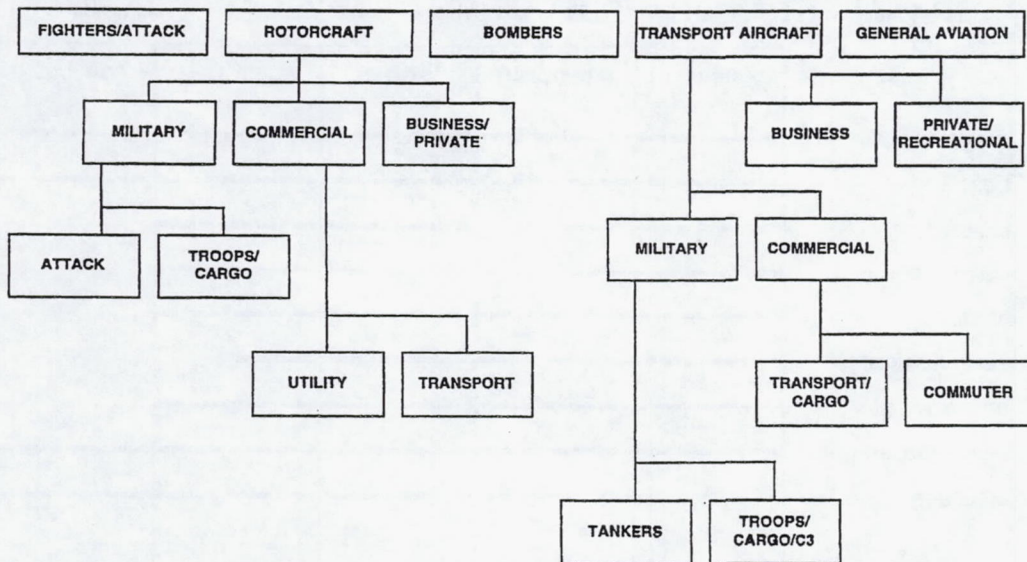

TOP LEVEL AIRCRAFT TYPE REQUIREMENTS BREAKDOWN

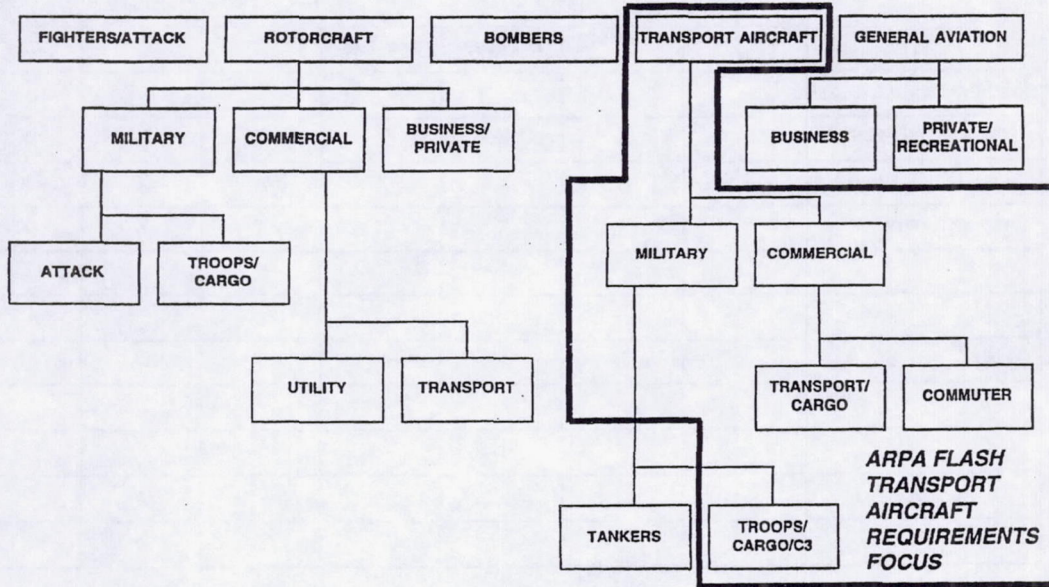

TOP LEVEL TRANSPORT AIRCRAFT COMMONALITY & COTS APPLICABILITY

	TRANSPORT C	TRANSPORT M	BUSINESS	BOMBERS	ROTORCRAFT C	ROTORCRAFT M	FIGHTER/ ATTACK
<i>E.O. COMPONENTS</i>							
CONNECTORS	X	X	X	X	X	X	X
SINGLE FIBER CABLE	X	X	X	X	X	X	X
MULTI FIBER CABLE	X	X	X	X	X	X	X
SPLICES	X	X	X	X	X	X	X
COUPLERS/BREAKOUTS	X	X	X	X	X	X	X
BACKPLANE	POTENTIAL	POTENTIAL	POTENTIAL	X	POTENTIAL	X	X
SENSORS	X	X	X	X	X	X	X

TOP LEVEL TRANSPORT AIRCRAFT COMMONALITY & COTS APPLICABILITY

	TRANSPORT C	TRANSPORT M	BUSINESS	BOMBERS	ROTORCRAFT C	ROTORCRAFT M	FIGHTER/ ATTACK
<i>F.O. PROCESSES & SUPPORT</i>							
TESTING/EQUIPMENT	X	X	X	X	X	X	X
INSTALLATION & MAINT.	X	X	X	X	X	X	X
AUTOMATED TERM. & INSP.	X	X	X	X	X	X	X



— **HR TEXTRON** — *Fly-By-Light* — **Honeywell** — *McDonnell Douglas Aerospace - West* —

CIVIL COMMERCIALIZATION PLAN APPROACH

- ADDRESS INSTALLATION MAINTENANCE, SAFETY AND PRODUCIBILITY AND ARCHITECTURE ISSUES UP FRONT
- CONDUCT MEANINGFUL, PRODUCT ORIENTED GROUND AND FLIGHT DEMONSTRATIONS FOR NEW AND RETROFIT APPLICATIONS
- INTRODUCE SMALL SCALE, SIMPLE, LOW RISK DESIGNS/APPLICATIONS INTO INITIAL FBL PRODUCTION TO GAIN CUSTOMER CONFIDENCE AND EXPERIENCE
- IN STEPWISE FASHION INTRODUCE MORE AND MORE COMPLEX APPLICATIONS INTO MULTIPLE AIRFRAMES

53-74

WHAT BCAG NEEDS FROM FIBER OPTIC SENSORS

ANTHONY A. LAMBREGTS
FLY-BY-LIGHT PROGRAM MANAGER
BOEING COMMERCIAL AIRPLANE GROUP

PRESENTED TO:
FIBER OPTICS SENSORS FOR AEROSPACE TECHNOLOGY WORKSHOP
OCTOBER 18-20, 1994

BCAG PROGRAM BUY - IN FOR NEW TECHNOLOGY IS ESSENTIAL

- o NEW TECHNOLOGY MUST BE WANTED (NOT JUST NEEDED OR REQUIRED) BY:
 - TECHNOLOGY "ADVOCATES"
 - ENGINEERING (ENGINEERS AND MANAGEMENT)
 - PRODUCTION PERSONNEL
 - AIRLINE ENGINEERING AND MAINTENANCE

DEVELOPMENT PROCESS TIME SCALE

- o TECHNOLOGY DEVELOPMENT vs AIRPLANE DESIGN CYCLE

- o TECHNOLOGY MUST BE SHEPHERDED THROUGH CHALLENGING TEST PROGRAMS
 - COMPONENT DEVELOPMENT
 - IN-SERVICE EVALUATION
 - SYSTEM DEVELOPMENT
 - FBL FLIGHT TEST SYSTEM DESIGN & DEMONSTRATION

FIBER OPTIC FBL & INSERVICE EVALUATION PROGRAM

85 86 87 88 89 90 91 92 93 94 95 96 97 98 99 2000 01

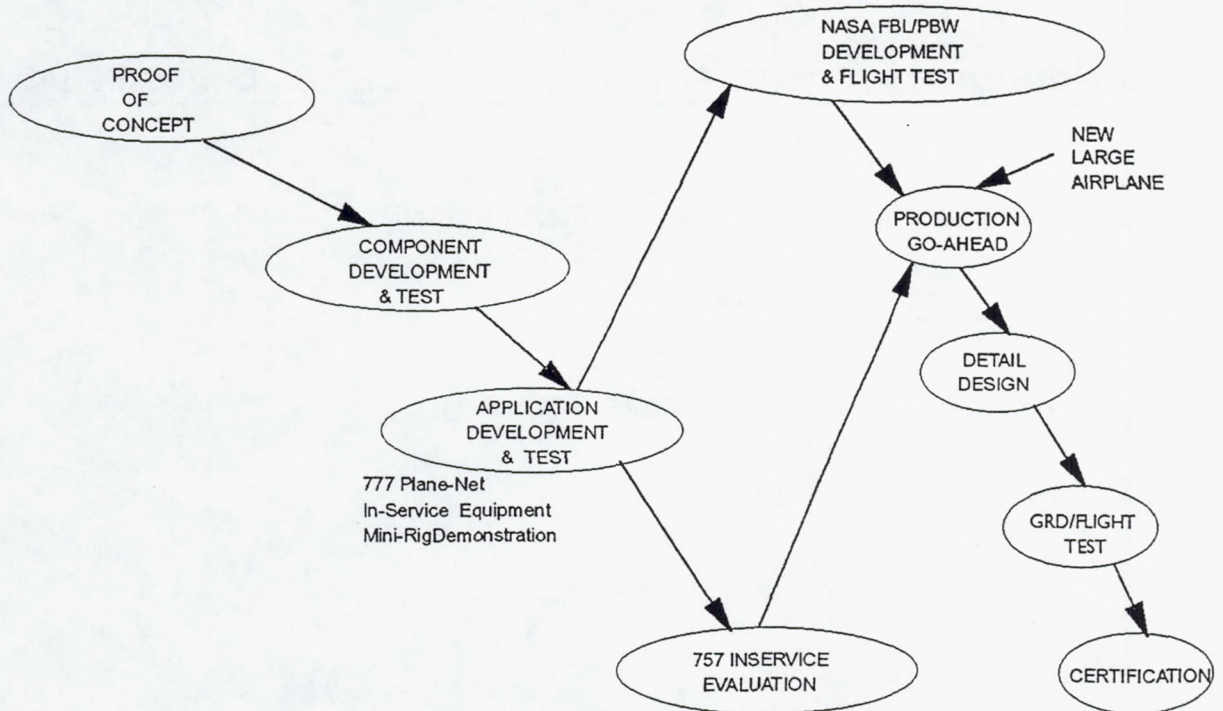

JUSTIFICATION FOR USING NEW TECHNOLOGY

- o FILLS A UNIQUE NICHE
 - TAKES ADVANTAGE OF THE APPLICATION:
WHEEL SPEED SENSOR
 - TAKES ADVANTAGE OF THE TECHNOLOGY:
ARINC 636 LAN (PLANENET ON BOEING 777) - BANDWIDTH
FADEC - DIGITAL SIGNAL ISOLATION
- o SHOWS QUANTIFIABLE, ROBUST SYSTEM BENEFIT DURING TRADE STUDIES:
 - PERFORMANCE
 - LIFE CYCLE COST
 - WEIGHT, VOLUME
 - RELIABILITY
 - MAINTAINABILITY
 - DEVELOPMENT RISK AND PROGRAM SCHEDULE RISK
 - AIRLINE LOGISTICS

APPLICATION OF FBL TO SYSTEM EVOLUTION

FLY-BY-LIGHT / POWER-BY-WIRE INTEGRATED REQUIREMENTS ANALYSIS AND PRELIMINARY DESIGN - BOEING RESULTS

NASA CONTRACTOR REPORT 4590, APRIL 1994

COVERS THE FOLLOWING FOR FLIGHT CONTROLS AND ENGINE CONTROLS:

- REQUIREMENTS FOR THE COMPLETE SYSTEM
- ARCHITECTURAL CONCEPTS
- TECHNOLOGY ASSESSMENT - INTERCONNECTS, SENSORS AND DATABUS
- TRADE STUDIES
- SYSTEM DEFINITION AND PRELIMINARY DESIGN

GENERAL TRADE STUDY CONCLUSIONS

SENSOR	COMPARISON TO ELECTRICAL:	COMMENT
WHEEL SPEED SENSOR	<ul style="list-style-type: none"> o LOWER WEIGHT o SIMPLER (MORE RELIABLE) o BETTER SIGNAL AT TAXI SPEED o INHERENTLY EMI/HIRF IMMUNE 	TAKES ADVANTAGE OF: <ul style="list-style-type: none"> o LOW SPEED (FREQ.) OUTPUT o LOW RESOLUTION REQMNT. o NON-DIRECTIONAL o TURNING WHEEL PROVIDES MODULATION o CLOSED OPTICAL SENSING PATH
LVDT / RVDT REPLACEMENT	<ul style="list-style-type: none"> o HIGHER COST-(XDCR,CABLES,E/O) o MORE COMPLEX - (XDCR, E/O) o LOWER RESOLUTION o BETTER STATIC ACCURACY o MORE STRINGENT SEALING o DIRECT DIGITAL INTERFACE o INHERENTLY EMI/HIRF IMMUNE 	<ul style="list-style-type: none"> o LOWER RESOLUTION AFFECTS PACKAGING o LIFETIME / RELIABILITY UNKNOWN o MULTIPLEXING LIMITED BY OPTICAL POWER BUDGET AND SIGNAL UPDATE RATES o BEST USED WHERE ELECTRICAL POWER IS AWKWARD TO PROVIDE
SWITCHES (PROXIMITY OR MECHANICAL)	EXPECT HIGHER PROX RELIABILITY	<ul style="list-style-type: none"> o NEEDS MONITORED/SUPERVISED OPERATION o MUST SUPPORT MULTIPLEXING (COST) o FLEXIBLE FIBER ENTRY TO PACKAGE

•
•
•
OTHER CONVENTIONAL SENSORS: PRESSURE, TEMPERATURE, ETC.

UNCONVENTIONAL SENSOR SYSTEMS

DISTRIBUTED ARRAY FOR STRAIN AND ACCELERATION, SENSING	<ul style="list-style-type: none"> o LIGHTER WEIGHT o NO "ANTENNA" EFFECTS 	o FOR SURFACE MODE SUPPRESSION AND WING LOAD ALLEVIATION
--	--	--

INDUSTRY ROLES

- o BCAG IS INCREASINGLY A SYSTEM INTEGRATOR, WITH RESPONSIBILITY TO UNDERSTAND THE TECHNOLOGY:
 - HOW IT WORKS
 - HOW TO APPLY IT
 - HOW TO INCORPORATE IT
 - DECIDE IF IT SHOULD BE USED
 - IMPLICATIONS TO THE AIRLINE CUSTOMER

- o SUPPLIERS' RESPONSIBILITY IS TO UNDERSTAND BCAG SYSTEMS AND PROBLEMS. INDUSTRY MUST DEVELOP COMPONENTS WITH THE FOLLOWING IN MIND:
 - MEETING THE QUANTIFIABLE REQUIREMENTS
 - PURSUE DESIGNS THAT TAKE ADVANTAGE OF THE TECHNOLOGY
 - REFINE PROCESSES TO PROVIDE CONSISTANT PERFORMANCE IN RELIABLE, LONG-LIVED COMPONENTS
 - DEVELOP THE PATH TO PRODUCTION
 - CONTINUE TO MATURE THE TECHNOLOGY - SEEK ALTERNATIVE MARKETS AND OPPORTUNITIES FOR GATHERING FIELD DATA
 - PURSUE COMMERCIAL VIABILITY
 - BE PREPARED FOR THE LONG-HAUL

- o GOVERNMENT AGENCIES
 - TAKE ON HIGH RISK TECHNOLOGY DEVELOPMENT
 - WORK WITH INDUSTRY
 - LEARN THE COMMERCIAL AIRPLANE BUSINESS PRACTICES

34-94

REVIEW OF PHOTONIC SYSTEMS REQUIREMENTS FOR PROPULSION CONTROLS



PRATT & WHITNEY

Chris Fields

**Navy Optoelectronic FADEC
Program Manager**

AGENDA

- Fiber Optic Sensors at Pratt & Whitney
- Benefits of Optic System
- Lessons Learned Summary
- Engine Control system Roadmap
- Evolution of FADEC Optics
- Optic Demonstration Programs
- Rocket Engine Sensors
- Lessons Learned
- Conclusion

FIBER OPTIC SENSORS AT P&W

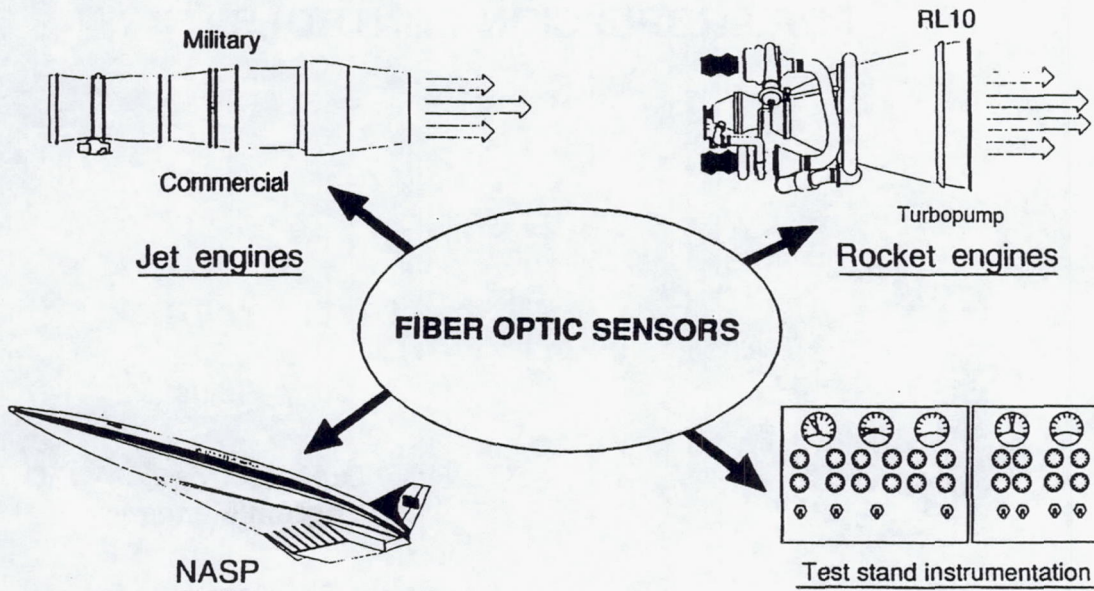

THE REASON FIBER OPTICS PURSUED AT P & W

Fiber Optics contribution to IHPTET weight-reduction goals increase aircraft performance, load capacity, and range

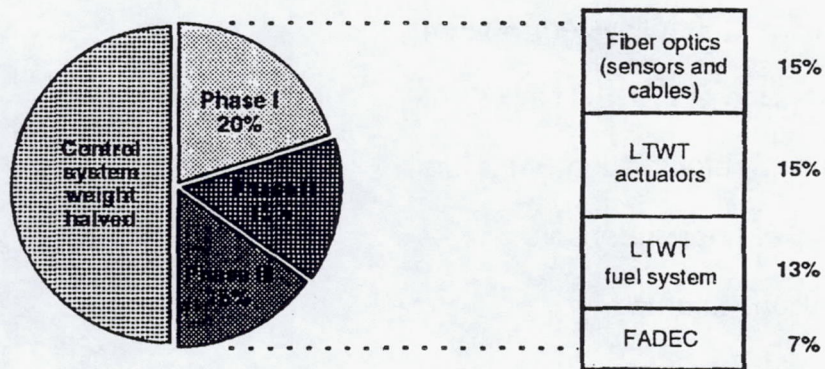

LESSONS LEARNED AFTER TEN YEARS OF FO DEVELOPMENT

FO Control System Components Need Improvement Before Use in Production Engines

Summary-

- FO sensors need future development and testing
 - Linear optic position sensor urgently needed
- FO sensor FADEC interface circuits need to be standardized and made smaller
- FO harnesses need improved high vibration optic connectors

Only two FO applications production ready-

1. Optic data bus from Flight Control to FADEC
2. Optic shaft speed sensor

ENGINE CONTROL SYSTEM ROAD MAP

Distributed Electronics System Architecture Surpassing Centralized System with Optics

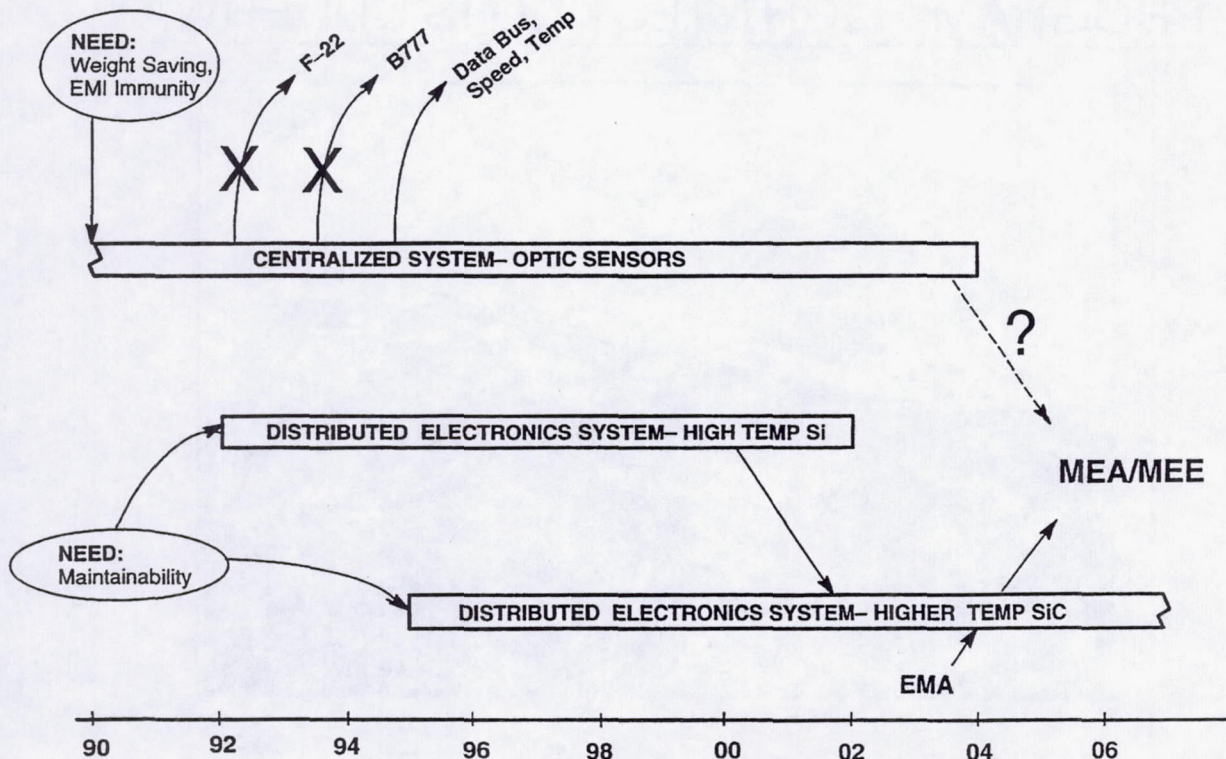

EVOLUTION OF FADEC OPTICS

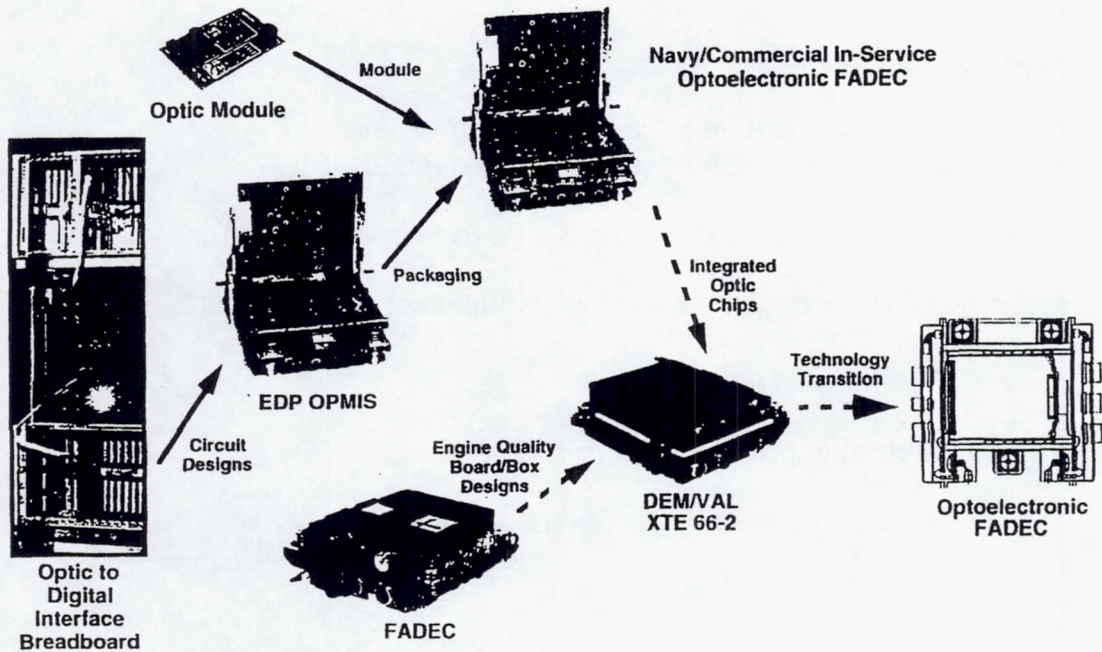

35562

BOEING FIBER OPTIC IN SERVICE PROGRAM FLIGHT TESTING IS UNDERWAY

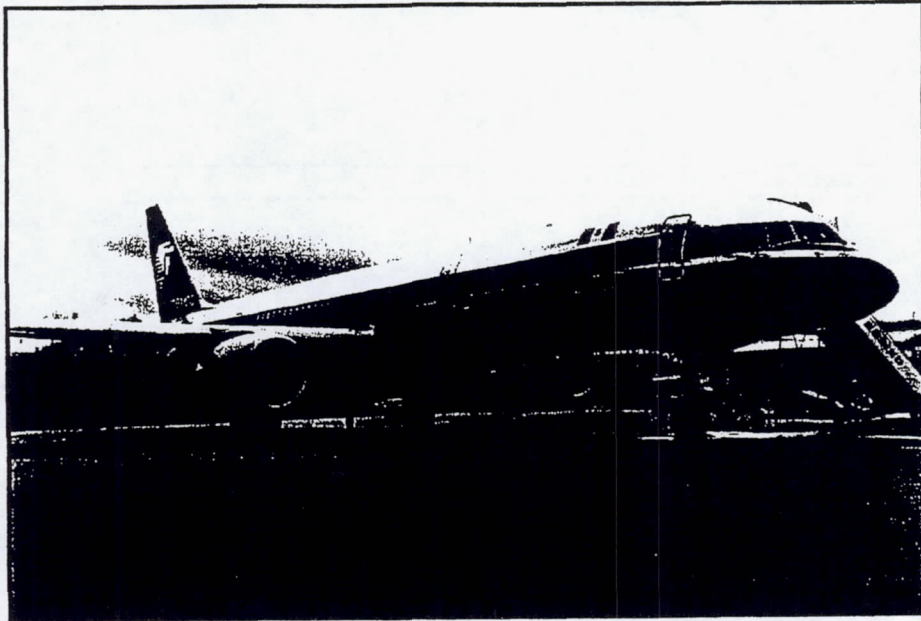

46836

OPMIS/NASA ATOPS AIRCRAFT INSTALLATION

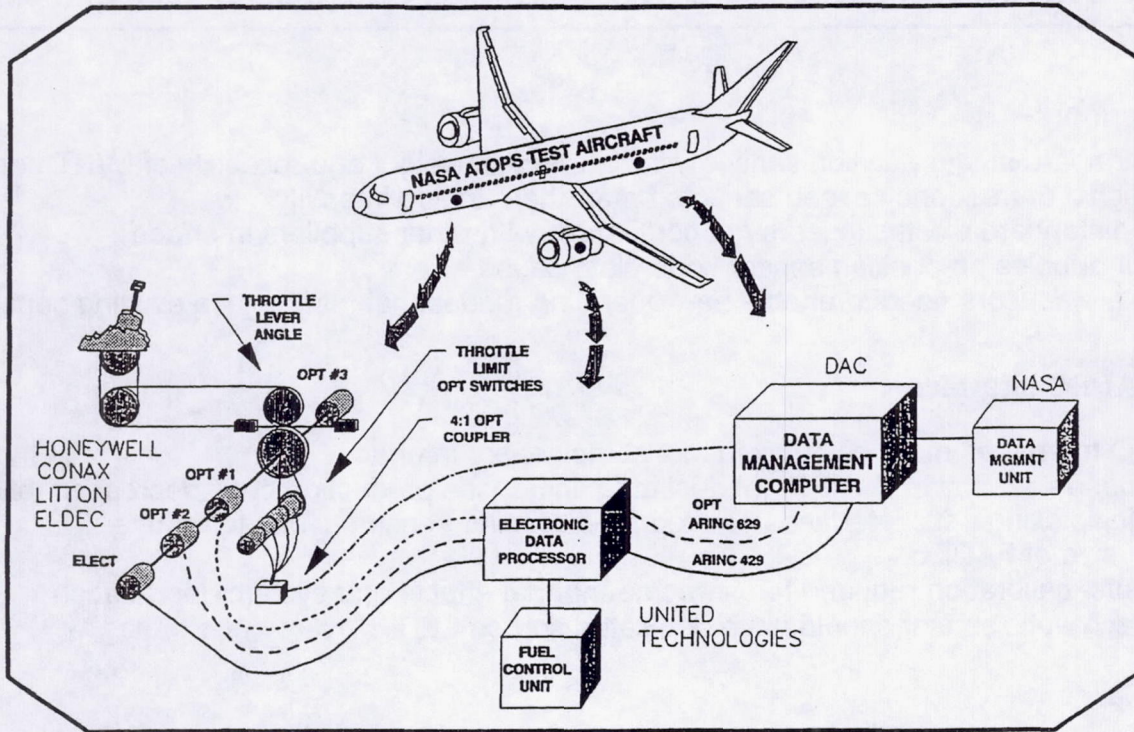

OPTIC SENSORS FOR ROCKET ENGINES NEED DEVELOPMENT

Multiplexed optic sensors can reduce number of housing penetrations

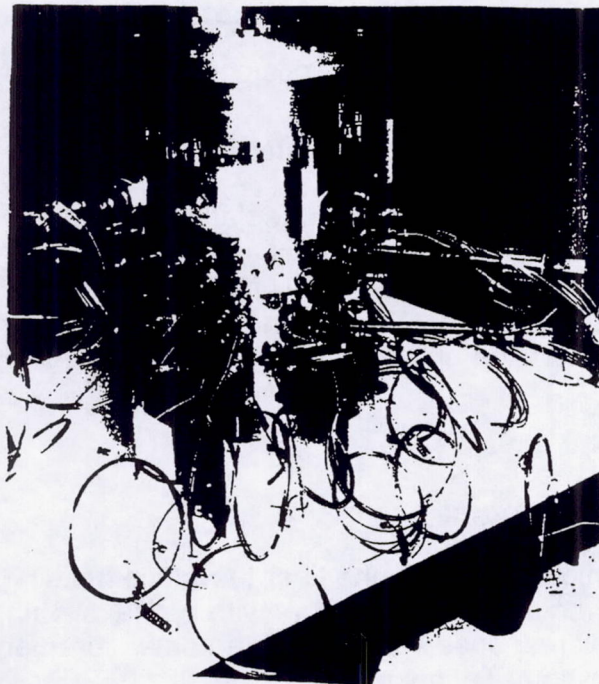

Turbopump with present electric sensors

ENGINE CONTROL OPTIC COMPONENTS LESSONS LEARNED

FO Sensors–

- Standard Linear position sensor with better cost, weight and reliability of LVDT needed
- Digital or frequency based sensors better than analog intensity
- No standard exists, sensors not compatible with other suppliers interface
- Air bubbles on position sensor code plate cause errors
- State sensors need to enable new operating modes, not just replace existing sensors

FO FADEC Interface–

- FO Interfaces more complex than electric sensor interfaces
- Loose fiber inside FADEC not desirable, increases production cost, decreases reliability
- Multiplexing optic interfaces needed for dissimilar sensors types to reduce size of FADEC
- Auto-calibration required to overcome thermal effects and system degradation
- Each optic sensor should have dedicated source LED

FO Harness–

- New FO connector for high vibration required
- Production Labor cost high
- Optic fiber must improve with less jacket shrinkage at high temperature

CONCLUSION

Pratt & Whitney requirements for further optic control system development

Jet engine control system optic components:

- Linear optic position sensor drop-in replacement for electric LVDT
- Multiplexed optic sensors on one fiber
- Smaller and standardized OE FADEC interfaces
- Smaller optic Data Bus remote terminal for FADEC
- Improved high vibration optic connectors for optic engine harness

Rocket engine optic sensors:

- Multiplexed optic sensors on one fiber to reduce housing penetrations
- Rotating shaft mounted optic sensors with optical slip rings
- High Frequency response sensor to extend measurement range
- Plume Spectroscopy Techniques
- Health Management sensors

58-74

Fiber Optics for Propulsion

Presenter: Kiyoung Chung, General Electric

CONTRACT NO. NAS3-25805
FIBER OPTIC SENSORS FOR ADVANCED AIRCRAFT PROPULSION

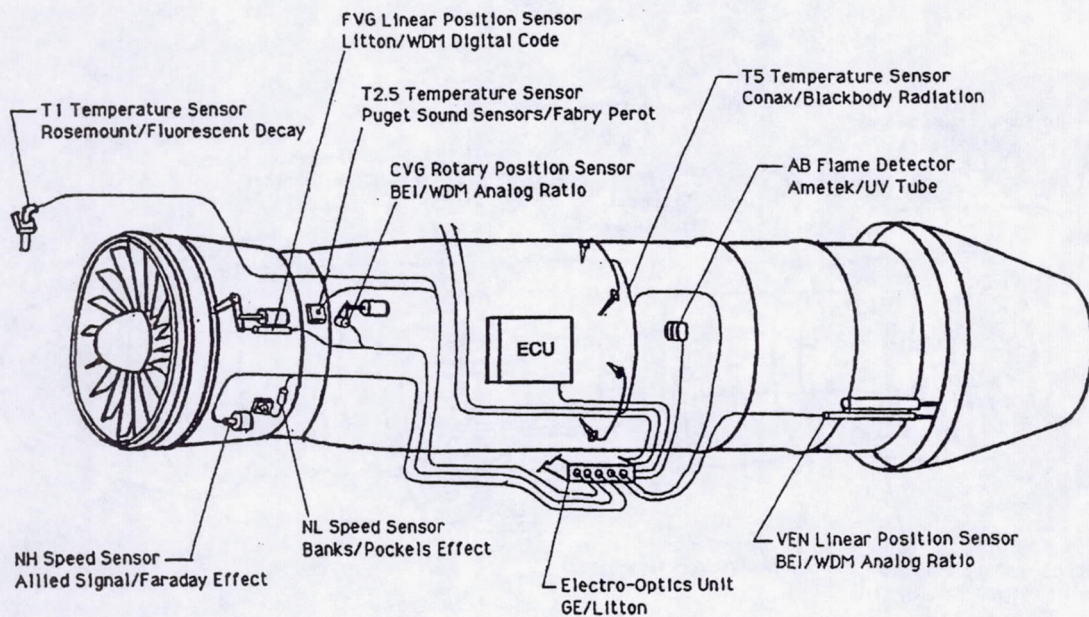

FOCSI FIBER OPTIC SENSORS ON THE F404-400 ENGINE

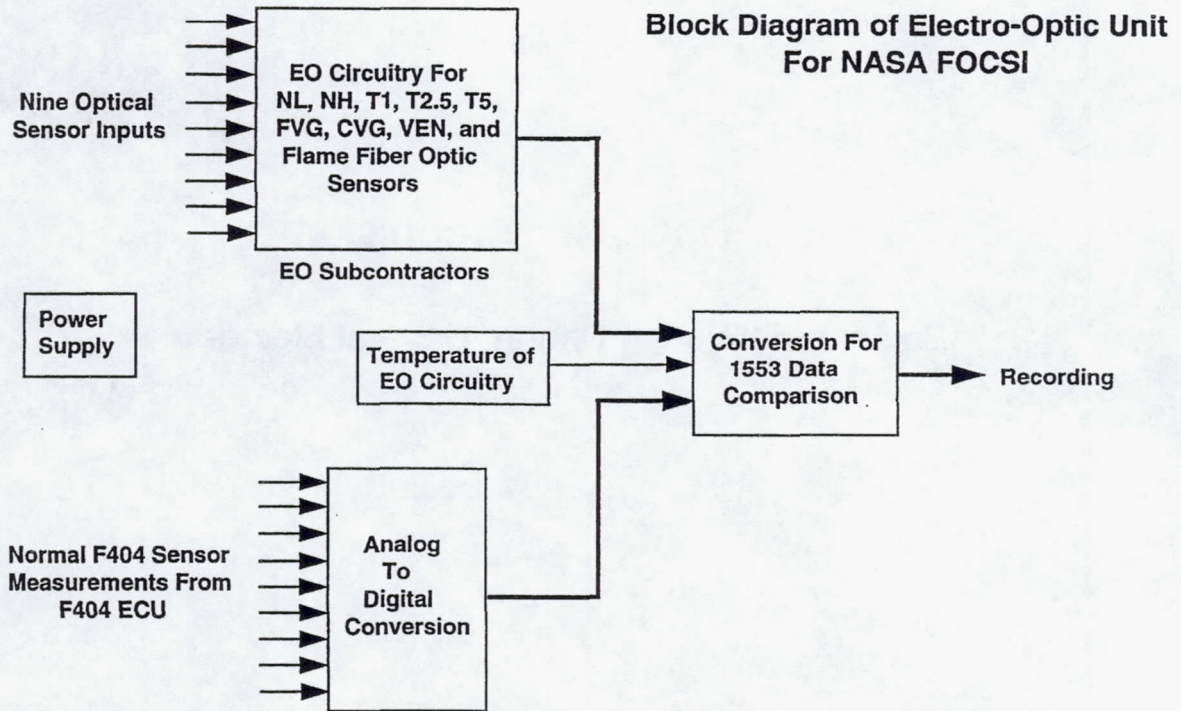

**CONTRACT NO. NAS3-26617, TASK ORDER NO. 34
F-18 OPTICAL CLOSED-LOOP PROPULSION CONTROL DEMONSTRATION**

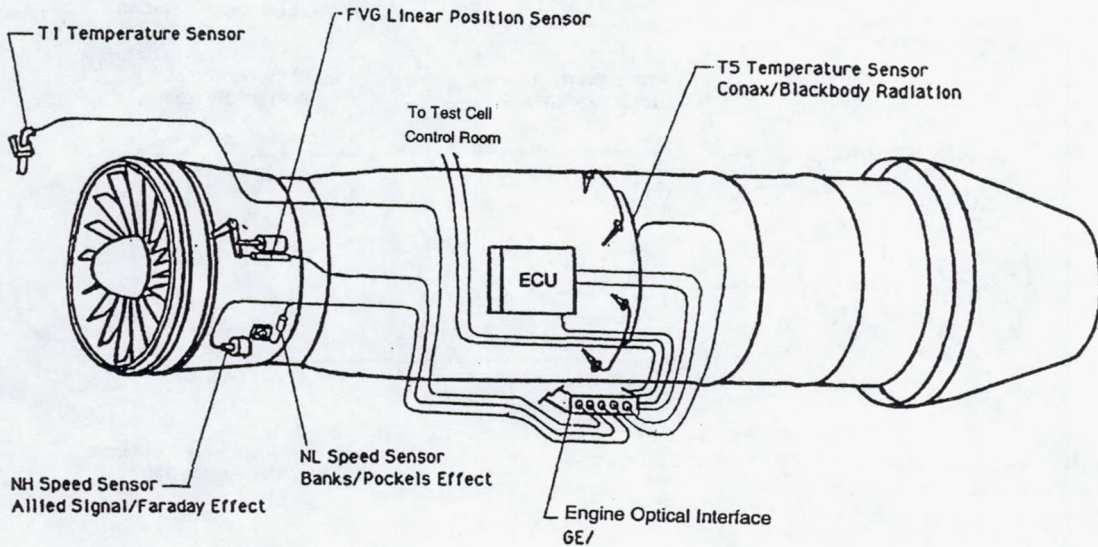

FIBER OPTIC SENSORS ON THE F404-400 ENGINE FOR CLOSED-LOOP CONTROL

Preliminary Block Diagram of Engine Optical Interface For NASA Optical Closed-Loop Propulsion Control Demo

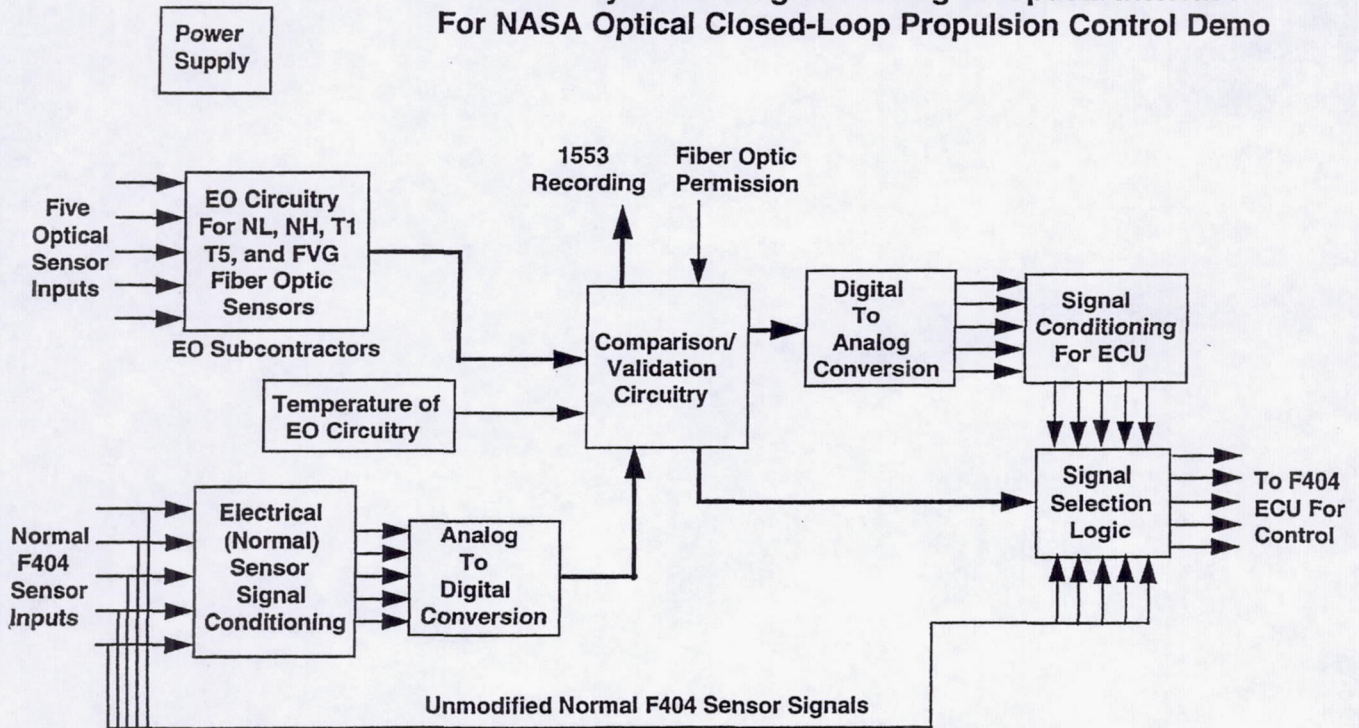

SUMMARY: CHALLENGES

- MULTIPLEXING - IDEALLY, ONE E-O CIRCUIT FOR ALL SENSORS
- SEALS FOR POSITION SENSORS - MOST IMPORTANT SENSOR FOR COMMERCIAL APPLICATIONS
- INTERFACE/INTERCHANGABILITY
- CABLES/CONNECTORS

ARE WE WORKING ON "RIGHT" TECHNOLOGIES ?

omit
to
END

Systems Session

Industry Chair: John Todd, McDonnell Douglas
Government Coordinator: Robert Baumbick,
NASA Lewis Research Center

SUMMARY OF DISCUSSION IN SYSTEMS WORK ELEMENT

Recommendations of the Systems Group stated that the government must take the lead in transferring technology to industry. Industry on the other hand must realize that the major competition is in the global market and that any government resources expended are for improvement of the U.S. Industries' competitive position. In the opinion of the group the government must fund critical development of high level prototypes. The work must focus on the users' needs. Small scale efforts will gain technology acceptance but the large scale benefits must be quantified. Inaction in providing this leadership will damage the role of U.S. Industry in the global marketplace. The consensus of the systems group members was that government and industry should form a steering committee to establish the needs/opportunities for this technology and clarify the benefits, educate the user and embark on an aggressive marketing effort to enable this technology to find its way into U.S. aerospace products. Further the steering committee should coordinate existing and future programs involving this technology and establish the means of technology transfer. Government programs should promote development of small scale efforts to gain technology acceptance. Beyond this the benefits to the users must be quantified and convincingly marketed. The technology will allow increased integration because of the higher bandwidth, eliminate the explosive potential around fuel areas, reduce unscheduled box removal because of EME upsets and will result in lower maintenance because of the absence of wire shielding.

An example of what a Joint Steering Committee would emphasize is illustrated here.

Government/Industry Optical Systems Technology Steering Committee

Technology Vision.—Improve U.S. competitiveness in the global marketplace by coordinating government/industry programs to advance optical systems technology for use in aerospace products. Help reduce barriers such as standardization, reliability, cost, supportability and maintainability.

Technology Goals.—Incorporate fiber optics and photonics into marketable aerospace systems. Reduce weight and costs of aircraft flight control and engine control systems. The near term and long term goals, referenced to the FBW (Fly-by-Wire) aircraft, are as follows:

	<u>Flight Controls</u>	<u>Engine Systems</u>
Weight:	10% reduction by 1998 25% reduction by 2005	Weight: 10% reduction by 1998 20% reduction by 2005
Cost:	30% reduction by 1998 40% reduction by 2005	Cost: 25% reduction by 1998 40% reduction by 2005

The use of fiber optics in commercial transport aircraft can result in a substantial weight reduction. Lower costs can be realized through reduced certification costs by doing box level certification. Reduced maintenance actions are also anticipated. Preliminary estimates of commercial aircraft life cycle cost savings using fiber optics, over the life of the aircraft, range between \$2-7 million.

REVIEW OF GOVERNMENT / INDUSTRY PROGRAMS IN OPTICAL SYSTEMS TECHNOLOGY

Listed below are a number of foundational programs that are funded by the government. The task is to transfer the technology developed under these programs to new programs and avoid duplication of effort while building up a database for the technology to eventually allow believable reliability estimates.

NASA

FOCSI (Fiber Optic Control System Integration).—The purpose of this program was to fly passive optical sensors, for both the aircraft and engine, on a F-18 SRA aircraft at NASA Dryden. Nine optical sensors were located near the production sensors on the engine and ten optical sensors were located close to the production sensors on the aircraft. Optical sensor performance was tracked over a number of flight conditions. An objective of this program was to establish and standardize the electro-optics interface unit on both the engine and aircraft. Valuable lessons learned from this program concerning hardware design and installation and maintenance experience will be used in the following fly-by-light programs. For further information concerning this program contact Robert Baumbick (216.433.3735) at the NASA Lewis Research Center.

FACT (Fiber optic closed-loop test).—The purpose of this program is to build upon FOCSI and add an optical feedforward loop to create an all optical control of a rudder and stabilator of the F-18 SRA aircraft at Dryden. The addition of optical feedforward loops for one rudder and one stabilator plus an advanced electro-optic interface unit represent advancement of the technology. Dual optical sensors were installed in the rudder actuator and quad optical sensors were installed in the stabilator actuator. Flight tests are expected to commence in 1QFY96 at NASA Dryden.

FIT (Fiber optic installation technology).— This program is part of the FACT program and is focussing on evaluating fiber optic installation techniques and evaluation of components such as active couplers. The installation simulates a transport aircraft installation in terms of fiber length and numbers of connectors. This effort seeks to document common failure modes of fiber cable harnesses and to establish guidelines for harness installation and maintenance procedures and processes. For further information concerning this program contact Robert Baumbick (216.433.3735) at the NASA Lewis Research Center.

FORM (Fiber optic reliability and maintainability).— This program is a cooperative effort between Sikorsky and NASA to evaluate optical fiber and optical harnesses which will be used for databusses in the Comanche helicopter. Currently, hardware is flying on an OV10 aircraft at NASA Lewis. For further information concerning this program contact Jorge Sotomayor (216.433.8303) at the NASA Lewis Research Center.

FBL/PBW (Fly-by-Light / Power-by-Wire).— This program is aimed at commercial transport aircraft. A FBL primary flight control will be designed for a target aircraft. A PBW design for the target aircraft will also be designed. A part of the design associated with the aileron and interfaced with a smart PBW actuator will be flight tested. For further information concerning this program contact Robert Baumbick (216.433.3735) at the NASA Lewis Research Center.

ARPA

FLASH (Fly-by-Light Advanced System Hardware).—This program is an ARPA program and its objective is to develop FBL/FCS (Fly-by-Light/Flight Control System) interfaces requirements, to develop optical interfaces between sensor suites and the FCS, to develop techniques and procedures for cable plants,

and to produce and install optical fiber harness into production aircraft systems. The program will also develop optical interfaces between FCC and FCS actuators. For further information concerning this program contact Dan Thompson (513.255.8288) at Wright Patterson AFB.

The people who participated in the Systems Session are listed below.

<u>NAME</u>	<u>COMPANY</u>	<u>PHONE / FAX</u>
John Todd	MDA - West	310.496.7417 / 310.496.9244
Kyoung Chung	GE Aircraft Engines	513.243.6291 / 513.243.6380
Tony Lambregts	Boeing Commercial	206.662.4220 / 206.662.0453
Kim Ennix	NASA / Dryden	805.258.2479 / 805.258.2842
Chris Fields	Pratt-Whitney	407.796.4063 / 407.796.4888
Don Halski	MDA - East	314.232.0157 / 314.232.4141
Dan Thompson	USAF / WL	513.255.8288 / 513.255.8297
Frank Banks	Banks Eng & Labs	619.452.1080 / 619.452.6708
Robert Heaston	IIT Res Inst.	312.567.4519 / 312.567.4889
W. Ross Rapoport	Allied Signal	201.455.5174 / 201.455.6575
Thom Schaffer	USAF WL/POTA	513.255.6690 / 513.255.0082
Bob Baumbick	NASA Lewis	216.433.3735 / 216.433.8643

Subsystems Session

Industry Chair: William Spillman, Simmons Precision
Government Coordinator: Grig Adamovsky,
NASA Lewis Research Center

What Do We Mean by a Subsystem?

SUBSYSTEM: a congregation of components interconnected in prescribed manner, performing certain functions, and capable of performing those functions in a stand alone fashion

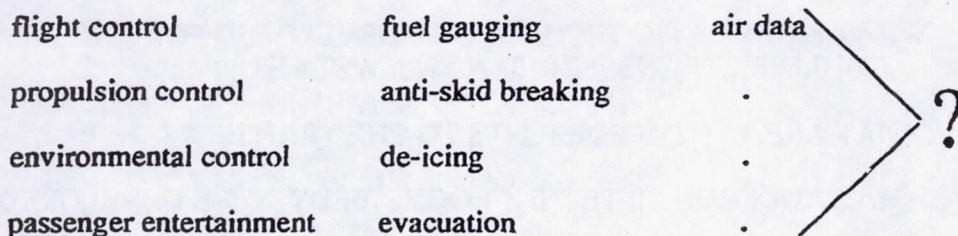

A Number of Issues Related to the Application of Fiber Optic Sensor and Communication Technology Need to be Addressed

A lot of money has been spent over a number of years on fiber optic sensor development, from ADOCS to FOCSS, FOCSI and FLASH.

WHY HAVE NO PRODUCTS RESULTED?

If there is a need, the current development process funded by the government must be flawed. How should it be modified in the future?

SHORTENED DEVELOPMENT CYCLES - HOW?

FOCUS OF FUTURE R&D - WHERE?

CO-OPERATION/COMPETITION - AT WHAT LEVEL, WHAT ORGANIZATIONS?

In considering dual use technology development, since introduction of technology into aerospace platforms takes a long time, should we

DEVELOP FOR AEROSPACE AND MODIFY FOR OTHER APPLICATIONS

or

DEVELOP FOR OTHER APPLICATIONS FIRST AND THEN MODIFY FOR AEROSPACE?

Subsystem Element
NASA FOSAT Workshop
October 18-20, 1994

From the Aerospace Subsystems which would
Benefit from Fiber Optic Technology, what Dual
Use Applications can be Envisioned?

WHAT FIBER OPTIC TECHNOLOGY DEVELOPED FOR AEROSPACE
COULD BE TRANSFERRED NOW? WHERE?

WHAT ARE THE IMPEDIMENTS TO THE TRANSFER?

WHAT ADDITIONAL TECHNOLOGY NEEDS TO BE DEVELOPED?

Subsystem Element
NASA FOSAT Workshop
October 18-20, 1994

Does the Use of Fiber Optic Sensor and
Communication Technology Offer Benefits for
Aerospace Subsystems?

WHICH SUBSYSTEMS WOULD BENEFIT?

OF THESE, WHICH HAVE NOT YET BEEN TAKEN
TO THE POINT OF TESTING?

WHAT IS THE CURRENT STATE-OF-THE-ART?

WHAT ADDITIONAL R&D NEEDS TO BE DONE
TO MAKE FIBER OPTIC TECHNOLOGY ATTRACTIVE
FOR USE IN SUBSYSTEMS?

HOW SHOULD THE BARRIERS TO USE BE OVERCOME?

Subsystem Element
NASA FOSAT Workshop
October 18-20, 1994

New Forms of Collaborative R&D are Required To Commercialize the Fiber Optic Sensor and Communications Technology

WHAT FORMS OF COLLABORATION HAVE BEEN TRIED IN
THE PAST?

WHAT HAS WORKED, WHAT HAS NOT, WHY?

WHO SHOULD COLLABORATE, WHY?

WHAT ROLE SHOULD SMALL BUSINESS PLAY?

**Subsystems in which the use of fiber optic sensor
and system technology might provide benefits**

- A. Flight control / propulsion control / air data
- B. Health management / Integrated diagnostic
- C. Intra-vehicle communications
- D. Stores management / Detachable systems
- E. Fire detection
- F. Environmental monitoring
- G. Electrical load management
- H. Fuel gauging

A.

FLIGHT CONTROL

Additional potential R&D activity:

- Distributed structural mode control
- Ingress/egress for embedded optical systems
- Large scale multiplexing
- Optical control loop at actuation point
- Distributed processing

Potential barriers:

- Competing technologies
- Investment cost
- Safety and reliability concerns
- Payoff is risky

AIR DATA

Additional potential R&D activity:

- High accuracy pressure measurements
- Good models of sensor / environment interaction
- Sensor integration

Potential barriers:

- Leap of faith required from customer
- Lack of extensive performance comparison data

B. HEALTH MANAGEMENT / INTEGRAL DIAGNOSTIC (STRUCTURAL)

Additional potential R&D activity:

- Structural failure detection
- Large scale multiplexing
- Ingress/egress to embedded FO systems
- "Smart" patch
- System design tools
- Data interpretation tools
- Distributed processing
- Methodology for determining "the cost of not knowing"

Potential barriers:

- Lack of advocates in the customer community
- Lack of "proof" that fiber optics provides enough benefits to be used

C. INTRA-VEHICLE COMMUNICATION

Additional potential R&D activity:

- Architecture development starting with optical links and a blank sheet
- Generic remote opto-electronic interface
- High temperature EMI resistant components
- High dynamic range trans. / receivers
- High integrity high speed protocols
- Digital multiplex bus

Potential barriers:

- Lack of components due to low potential volume

D. STORES MANAGEMENT / DETACHABLE SYSTEMS

Additional potential R&D activity:

- Standard optical interface
- Optical data management
- Standard optical connector
- High bandwidth data trans. system (>1 GHz)
- Components, circuitry, processing

Potential barriers:

- Potential customers are not aware of technology
- Lack of communications between technology developers and customers
- Divergence of requirements between commercial telecom and aerospace

E. FIRE DETECTION

Additional potential R&D activity:

- Flight test evaluation, certification, and validation

Potential barriers:

- Lack of full set of components

F. ENVIRONMENTAL MONITORING

Additional potential R&D activity:

- Sensor specifications
- Re-engineering of existing sensors for aerospace
- Sensor testing
- Flight test / certification / validation

Potential barriers:

- Uncertainty as to the form and timing of future environmental legislation
-

G. ELECTRICAL LOAD MANAGEMENT

Additional potential R&D activity:

- Fiber optic sensor development
- Fiber optic switch development
- Integration of sensors with electrical actuators

Potential barriers:

- convincing customers that there is a need and fiber optic fills it
-

H. FUEL GAUGING

Additional potential R&D activity:

- Tank wall data concentrator with fiber optic link
- Fiber optic sensors for high accuracy measurement of level, pressure, density, or mass

Potential barriers:

- Existing technology works very well

Potential R&D needed

Some common threads

- Multiplexing
- Environmentally robust components and interfaces
(high T, EMI resistant)
- High accuracy pressure measurement
- Distributed processing
- Connectors (standard and for ingress/egress for fiber
optic systems embedded in composite structures)
- Standards development

**Potential Applications of the Aerospace
Subsystem Technology in Non-Aerospace**

- A. Flight controls / adaptive wing
 - submarines, ships
 - race cars, surface effect
 - vehicles, trucks & motorcycle

- B. Health monitoring/ Int. diagnostics
 - process control
 - nuclear vessels
 - oil refinery, off-shore platforms (insurance)
 - truck transmissions
 - residential structures
 - flywheel health

- C. Intra-vehicle communication
 - automotive
 - rail transport. systems
 - harsh factory environment
 - submarines (unmanned submergible)
 - ships (cruse, oil tankers)
 - unmanned telemetry ground stations

- D. Stores management / detachable systems
 - shipping containers
 - electric cars (change battery packs)
 - warehouses (inventory)
 - amusement park (various rides) interactive v/games

- E. Fire detection
 - combustion sensing

- F. Environmental monitoring
 - automotive, truck, plant emission
 - air pollution monitoring

- G. Electric load management
 - substations
 - electric locomotives
 - trolley cars, subways

- H. Fuel gauging
 - hazardous chemicals
 - tankers
 - storage tanks

PRIORITIZATION

	For aerospace applications	For transfer to non- aerospace applications
A. Flight controls	2	3
B. Health monitoring	3	1
C. Intra-vehicle commun.	1	1
D. Stores management	5	4
E. Fire detection	4	7
F. Environmental monitoring	6	2
G. Electrical load monitoring	8	5
H. Fuel gauging	7	6

Prioritized list of "commercial" technical areas that could benefit aerospace fiber optic applications

1. Communication components
2. Medical sensor technology / process control sensors
3. High speed computation
4. Entertainment

Subsystem Element Recommendations to NASA

1. Long term development of "all" optical X-Vehicle
2. Low cost available test bed(s)
3. NASA should focus on development of technology infrastructure needed to support sensors / subsystems already fielded
4. NASA should survey fiber optic sensor / system supplier / user (aerospace) and ask the following questions:
 - In what areas of Fly-by-light would you like to collaborate in ?
 - What capabilities can you provide ?
 - What are your critical needs / expectations from suppliers in the area ?

Workshop Critique

Compare NSF Model and the NASA FOSAT Workshop

1. NSF Model

- small groups of experts covering the range of the research area
- each group is a microcosm of the whole but focuses at a different segment of the research area
- NSF personnel keep the minutes of the group meeting
- a general meeting of all groups is then used to make recommendations for future work, but NSF makes its own decisions based on the meeting minutes

2. NASA FOSAT

- not structured enough
- distribution of people was uneven, too many in some groups not enough in others, expertise was not spread out
- mission of workshop groups (as opposed to whole) was fuzzy
- should have had systems group meet prior to the workshop to define the roles of the lower level groups and provide them with an outline to follow

COLLABORATION ISSUES

Sources of collaboration success

- Teaming to reduce cost / risk
- Complementary capabilities
- Has to make sense in a business mission context for all partners
- Clear legal understanding between the partners

Sources of collaboration failure

- Procurement problems
- Partnership disagreement on payoff
- Timing, rules for proposal
- Companies forced into being "strange bedfellows"
- Cultural differences between the companies

Who should collaborate and why ?

1. Aerospace Industry (all)

primary business
includes customers and suppliers

2. Commercial Industry (non-aero) (medium sized & smaller, preferably)

cost effectiveness
dual use

3. Government Labs (w/ aerospace affiliation)

they have bucks (we hope)
they have test facilities
they have experts in corresponding fields

4. Academia

(selected professors for consulting)
(centers of excellence set up by the government)
(univ. w/strong fiber optic tech. programs)

access to unique expertise
access to unique facilities

5. Small Business ("SDB")

(those with a definite contribution to make)

high incentive to succeed
lower overhead

6. Standards Organizations

there will be no products without standards

Sensors/Actuators Session

Industry Chair: Steve Emo, Allied Signal
Government Coordinators: Glenn Beheim and Margaret Tuma,
NASA Lewis Research Center

MINUTES FROM SENSORS/ACTUATORS SESSION

MARKET DEMAND - WHERE IS IT ?

- Specifications
- Standards
- Why isn't the technology here yet?
- Life cycle cost
- Acquisition cost
- Reliability data

NICHES

- 1) Where EMI or corrosion presents problems
- 2) High data rates
- 3) Chemical interaction
- 4) Size
- 5) Non-intrusive
- 6) Explosive/nonsparking
- 7) Embedded structural and life sensors
- 8) Multiplexing
- 9) Distributed/area/volume

NEEDS

- 1) Low cost
- 2) Market
- 3) Reliability data
- 4) Multiplexing
- 5) E-O packaging techniques

SPECIFICATIONS FOR OPTICAL SENSORS FOR AEROSPACE AND INDUSTRIAL COEFFICIENTS

SENSOR	SPACE	INDS	AUTO	PROPUL	AIRCRAFT	MED	MARINE
Pressure	0.01% 0.1%	0.1% 5.0%	0.1% 5.0%	0.1%	0.02% 5.0%	0.01% 0.1%	0.1% 5.0%
Temperature	25-2500 °C	0-++	-40-800 °C	-55-850°C	-55-125 °C -55-? HST	Cryo-40 °C	-4-800 °C
Flow Gas Liquid	0.8M <25 ft/s	0.3M <25 ft/s	<0.05M -----	0.3-0.9M up to 3M 100 ft/s	<25 ft/s	Unknown	0.3-0.9M 50 ft/s
Position	0.03-12"	10 ft	0.03-4" (collision)	0.03-10"	0.03-20"	Artificial Limbs	0.03-10"
Strain Range	10µε/10 ⁴	5%	-----	-----	10µε/10 ⁴	?	10µε/10 ⁴
Acceleration/ Vibration	5-1600 G	20-	2-50 G	20-50 G	0.5-10 G	-----	20-50 G
Liquid level	-----	ALL	1'	-----	3'	-----	-----
Substance	H ₂	ALL	O ₂ , H ₂ , CO ₂ , NO _x	-----	debris	anything and ALL	Salt, pH, humidity
Speed	-40 K	ALL	ALL	YES	YES	6B man	YES
Prox.	Eng. blade	ALL	ALL	YES	YES	YES	-----
E-Field	YES	ALL	ALL	-----	YES	EKG EEG	Mine & Threat

BARRIERS

COST:

- 1) DFMA
- 2) Calibration/Stability
- 3) Life cycle cost

NONCOST:

- 4) Packaging
 - seals (hermetic, etc)
- 5) Adhesives temperature rating
- 6) Connector
- 7) Vendor stability
- 8) Component temperature rating
 - Fiber
 - Epoxy
 - Detectors, etc.
- 9) Education
- 10) Amplifiers
- 11) Single-mode fiber (aircraft environments)
- 12) Switches

ASSESSMENT OF PRESENT SENSOR STATUS

	<u>RATING</u>	<u>NUMBER VOTING</u>
PRESSURE	3.1	20
TEMPERATURE	3.4	18
FLOW	1.7	12
POSITION	3.3	15
STRAIN	2.8	12
ACCELERATION	2.7	12
LIQUID LEVEL	2.0	12
SUBSTANCE	3.5	13
SPEED	3.9	10
PROX.	4.4	14
ELECTRIC Param.	2.6	11

_____KEY

NOT A CLUE	-0
CONCEPT	-1
LAB DEMO	-2
FIELD DEMO	-3
APPLIC. DEMO	-4
QUAL/CERT	-5

ASSESSMENT OF PRESENT SENSOR STATUS—COST READINESS

	<u>RATING</u>	<u>NUMBER VOTING</u>
PRESSURE	3.1	16
TEMPERATURE	3.1	16
FLOW	3.1	7
POSITION	3.0	12
STRAIN	2.7	9
ACCELERATION	3.6	11
LIQUID LEVEL	3.0	9
SUBSTANCE	2.8	8
SPEED	3.7	7
PROX.	3.6	14
ELECTRIC Param.	3.2	6

KEY

WAY TOO HIGH	-2
SLIGHTLY HIGHER	-3
EQUAL COST	-4
LESS COST	-5

COMPONENT DEVELOPMENT (WDM)

Custom receiver detector array

Demux elements

Sources

Couplers

INTERFACE REQUIREMENTS

Cost/sensed function (e.g., 12 bit pos \$1,000 or \$50 to \$100/bit)

Number of bits/E/O Interface Model Demux elements

Number of optical I/O ports; 16 max

Output protocol

Onboard signal processing requirements

INTERFACE TYPES

WDM - Wavelength Division Multiplexing
- 2 lambda sensors

TDM - Time Division Multiplexing

LFOS - Ladar f-o sensor (time-delay frequency sensor)

PPM - Post Position Modulation

Pattern Recognition (Intensity)

TRD - Time Rate of Decay - Fluorescence Decay

FM - Frequency Out

Intensity

Must Prioritize Interface Types

SINGLE MODE VS. MULTIMODE SENSORS

	<u>RATING</u>	<u>NUMBER VOTING</u>
PRESSURE	3.2	12
TEMPERATURE	2.9	14
FLOW	3.2	9
POSITION	3.0	11
STRAIN	2.8	10
ACCELERATION	3.6	10
LIQUID LEVEL	3.6	10
SUBSTANCE	2.8	10
SPEED	3.8	12
PROX.	3.9	11
ELECTRIC PARAM.	2.6	10

KEY

ONLY SINGLE MODE	-1
MOSTLY SM	-2
BOTH SM AND MM	-3
MOSTLY MM	-4
ONLY MULTIMODE	-5

I) WHAT ARE THE POTENTIAL MARKETS FOR FIBER-OPTIC SENSOR?

1) AEROSPACE

- 2) BUILDINGS - Civil Applications
-environmental, fire, security, structural health

RATIONALE: distributed (1 fiber), multiplexing potential

- 3) PROCESS CONTROL - P, T, position, flow

RATIONALE: harsh environment, safety, EMI

- 4) MANUFACTURING - T, P, position, inspection, liquid level, color, flow

RATIONALE: harsh environment, safety, EMI

- 5) AUTOMOTIVE - position, P, T, chemical, proximity, substance

RATIONALE: EMI, harness weight reduction, harsh environment

- 6) NUCLEAR INDUSTRY - P, T, total radiation, etc.

RATIONALE: EMT

- 7) TOYS -

- 8) MEDICAL - P, blood chemistry

RATIONALE: Size, cost, reusable, inspection

- 9) MARINE -

RATIONALE: Salt, environment

II) WHAT WORK IS REQUIRED TO ACCESS THESE MARKETS?

(assume concept has been demonstrated in field/environment)

- 1) Prove reliability, endurance
- 2) Show promise of reduced cost
- 3) Identify real superior performance
- 4) Marketing
- 5) Strategic partnerships
- 6) Identify sponsor

Standards organization?

III) WHAT PARTNERSHIPS SHOULD BE FORMED TO IMPROVE U.S. COMPETITIVENESS?

- 1) Airframe/Vendor/End user - Airlines
- Military
- 2) Gov't Lab/Industry/University (e.g., Space Act Agreement)
- 3) Multiple company partnerships
-e.g., high T fibers and high T connector companies
- 4) U.S. Fiber Optic Sensor Consortium - sensor vendors, cable vendor, connector vendor, E/O, universities, Gov't lab
- 5) European partnership
- 6) Government/Vendor information exchange: no money involved

IV) DEVELOP A PLAN TO GUIDE FUTURE RESEARCH

Are there any sensors needed immediately?

AUTOMOBILE

- Hydrocarbon concentration in exhaust
- CO, NO_x

AEROSPACE

- Hydrocarbons
- NO_x
- Tip clearance
- Non-intrusive flow meter

Government sponsored information exchange

INFORMATION sharing - How do we do it?

- Internet site, share ideas (bulletin board, ftp)
- send information out on e-mail

WS 2 - SENSORS GROUP

GENERAL COMMENTS AND COMMENTS ON FOSAT WORKSHOP

- 1) NASA's objectives for workshop
 - What will be done with the information?
 - a) redirect existing funds accordingly
 - b) argue for budget (R&D)
 - 2) Should concentrate on aerospace requirements
 - go into detail on requirements (it was mentioned one can get this information from Boeing)
 - 3) Look at longer time-range
 - aerospace sensor applications are limited
 - 4) Don't have right mix of people in the workshop
 - (as implied in FOSAT title - need higher level people)
 - 5) Need to understand system to determine marketability problems (usability)
 - 6) Distributed control
 - f.o. not advantageous (conversion part count increase)
 - 7) Integrated sensor and circuit on same chip - or multichip module (reliability - due to environment)
 - 8) Comparison between electronics and f.o. (on same system)
 - note equivalency and trade-offs
 - 9) Redundancy - Architecture study not addressed
 - 10) Information dissemination - Would like to get bibliography of reports (FOCSI, etc.)
 - 11) Would like a session on how to sell f.o. technology internally to management
 - 12) It is hoped that NASA will continue to utilize small businesses, sentiment that they are more able to carry out risky ventures. It was pointed out that NASA is required to spend a certain amount of its budget on small business ventures and will hopefully continue to do so.
- Need standardization
- newer technology comes along - but not compatible with standard
 - then develop a new standard
 - if I have the best method - I don't want to use the std
 - 1553 standard OK
 - fragmented now
 - Now is time to determine
 - good to have a datasheet so electronics guys can build it to into a FADEC
 - better analogy - IBM - INTEL did chip, IBM software
 - NEED A SPEC SHEET
 - 780-890 nm 10 nm spacing, res. 2-3 nm SOA
 - Sensor processing - before or after electronics
 - Interface won't work

WDM - Most used, met resistance with group

NEED TO COME UP WITH STANDARDS FOR EACH TYPE

Way for market to grow is for standard small company can buy and develop sensors

NASA should endorse standards

Fiber Optic Sensors Issues and Answers ?

Raymond W. Huggins

Mahesh C. Reddy

October 18-20, 1994

Agenda

FO sensor systems

- Attributes
- Applications

FO sensor building blocks - Issues

- Transducers
- Interfaces
- Cables and connectors
- HIRF immunity

FO sensor building blocks - Answers ?

- Cost reduction
- Power margin

FO sensor building blocks - Cost projections

Military standards

Summary

Sensor Systems

*Boeing
Defense &
Space Group*

FO Sensor Systems - Attributes

Advanced Vehicle Management Systems

Weight Savings

- Primarily through replacement of wire by fiber
- Additional savings when composite connectors developed

Costs

- Studies show
 - one interface board must service 64 - 80 data bits to be cost effective
 - Have to multiplex several transducers on one fiber loop

HIRF Immunity

- Questions raised

**TRIPLEX SYSTEM
REPLACEMENT OF SENSORS ONLY**
(includes weight of transducers, cables & connectors, and electronics)
No Fiber Multiplexing

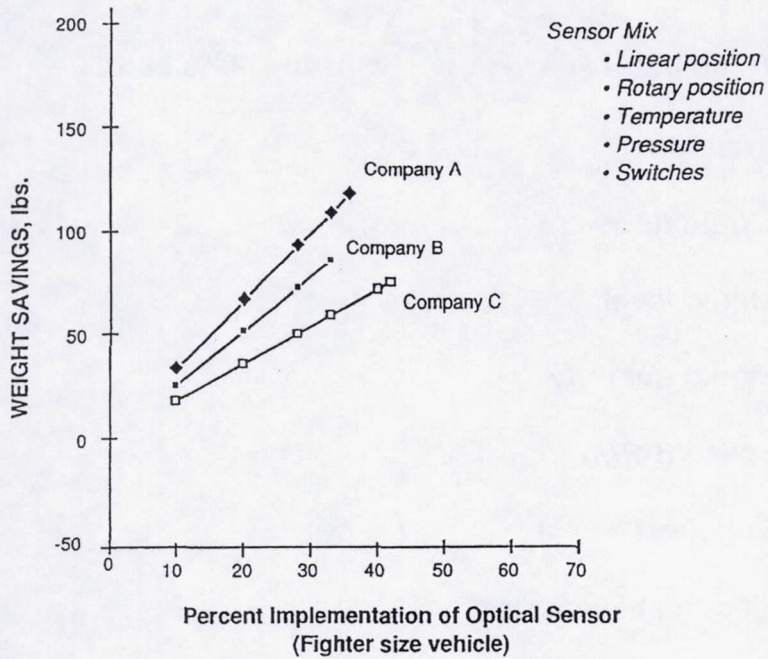

Boeing
Defense &
Space Group

FO Sensor Systems - Military Applications

Advanced Vehicle Management Systems

Can potentially replace 60% of Sensor Types on fighter

Insertion time at least 10 years

Partial list of aircraft electrical sensors

Advanced Vehicle Management Systems

Position	}	40 - 60 % of total
Temperature		
Pressure		
Liquid flow		
Liquid level		
Liquid quantity		
Speed (RPM)		
Switches		
Electrical - various		

Sensor Building Blocks - Issues

Advanced Vehicle Management Systems

Transducers

Interfaces

Cables and Connectors

Modulation schemes

Wavelength Division Multiplexed (WDM)

- Most mature
- Pilot production
- Includes 2λ sensors

Time Division Multiplexed (TDM)

- Flight prototype
- Complex
- Reliability questions
- Reduced industry effort

Laser Fiber Optic Sensor (LFOS)

- Least mature
- Laboratory demonstration
- Potential advantages ...
- Size and cost of interface needs work

WDM Transducer Status

Parameter	Demonstration Status	Maturity
Linear/Rotary Position	Engine Test Bed Flight Test	Pilot Production
High Temperature (Pyrometric)	Engine Test Bed Flight Test	Production Prototype
Low Temperature	Engine Test Bed Flight Test	Flight Prototype
Pressure (>1%)	Engine Test Bed Flight Test Plant Test	Flight Prototype
Pressure (>0.02%)	Not Available	No Ideas
Switches (When Speed)	Engine Test Bed Flight Test	Pilot Production

Transducers - Issues

Advanced Vehicle Management Systems

Long term environmental performance

Long term stability/reliability

Cost reduction

- Manufacturing
- Generic Optics

Multiplexing essential in some instances

No high accuracy pressure sensor (0.02%)

INTERFACES

Interfaces - Issues

Advanced Vehicle Management Systems

Fiber routing on board

- Bend radius
- Anchoring
- Repairability
- Manufacturability

Box - rack interface connector

- Geometry
- Repairability
- Contamination
- Losses
- Cost

Electro-optic components

- Not yet optimized

HIRF immunity

- Not proven for FO sensor interfaces

HIRF Susceptibility

HIRF susceptibility test results inconclusive

Principle benefit in low frequency (< 400 MHz) regime

- Wire cables eliminated

Threat to interfaces in high frequency (400 MHz to 20 GHz) regime

- No advantage over electrical sensor interfaces
- Optical sensor interfaces may be more susceptible (nW optical power levels)

Need tests on FO interfaces to resolve susceptibility issues

Potentially no problem if care is taken with LRU enclosure design

CABLES & CONNECTORS

Cables & Conectors - Issues

Long term environmental performance and reliability

Limited performance data available under combined environmental conditions (e.g. temperature and vibration)

No models for lifetime predictions

Variable and non- repeatable insertion loss

End of life insertion loss unknown

Connector termination process

Field installation and repair

FO Sensor System - Answers?

Cost

- Multiplexing essential
 - Interface level
 - Loop level

Power margin

- Custom Detector array
- Alternative sources

HIRF Susceptibility

- Tests needed

Broadband Optical Source Sensor System Performance

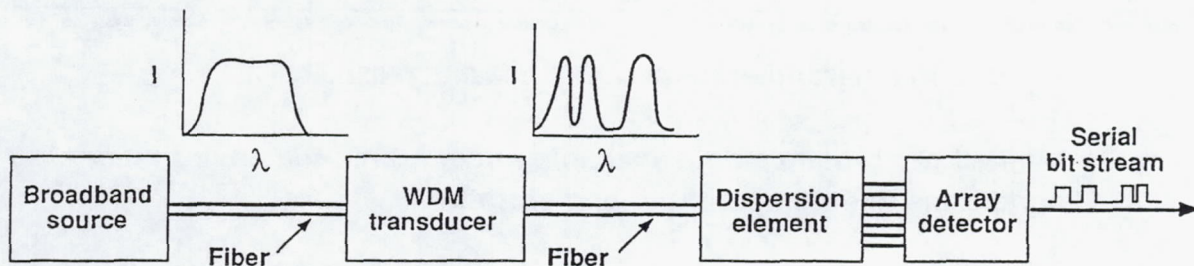

- 100 nm useable spectral width
- 500 μ W total optical power into 100 μ m diameter core fiber
- 20 channels
- 5 nm/channel
- 1.25 μ W/channel (allowance made for guard band)

Demultiplexer Losses

Mismatch between CCD pixel width (13 μm) and fiber diameter (100 μm)	- 9 dB
Gap between CCD pixels	-1 dB
Diffraction grating efficiency (50%)	-3 dB
Excess optical losses	-1 dB
<hr/> Total <hr/>	<hr/> -14 dB <hr/>

Custom CCD array gives 10 dB improvement

Swept Wavelength Optical Source Sensor System Requirements

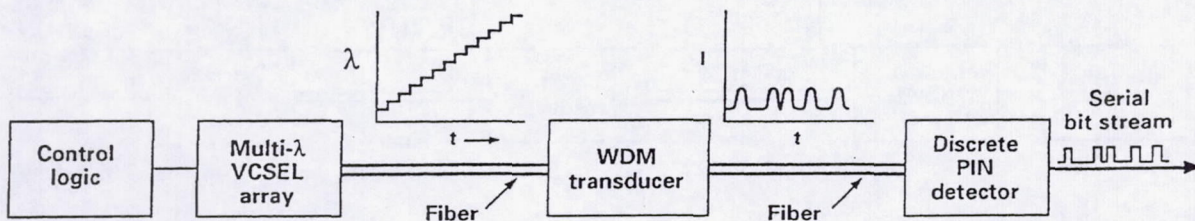

- Wavelength range goal of 100 nm (40 nm demonstrated)
- 5x5 minimum array of individually addressable VCSELS
- 2 – 4 nm VCSEL wavelength separation between VCSELS
- Efficient coupling of all VCSELS in array into 100 μm core fiber
- 1 mW/VCSEL optical power coupled into fiber
- Ambient temperature up to 125°C (goal) 1 nm/20°C drift

VCSEL sources for FO sensors

Almost 30 dB increase in optical power/channel (1.25 μ W to 1 mW)

Eliminates demultiplexing detector

Potential cost reduction per sensed function - 20 x reduction

Potential cooperative effort with university

Benefits of VCSEL F-O Source

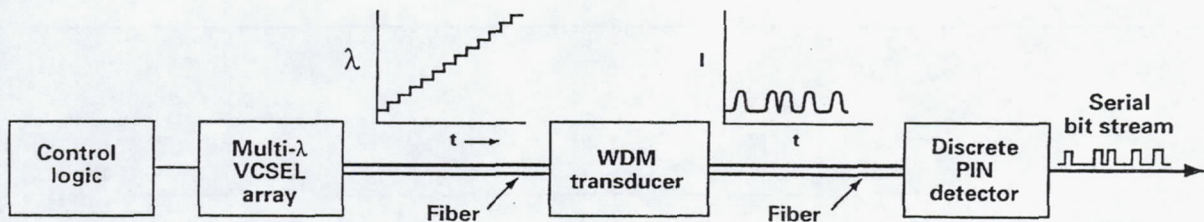

- Simpler optical interface — improved reliability, reduced weight and size
- 43 dB power margin increase
 - 29 dB increase in optical power/channel
 - -14 dB demultiplexer receiver loss eliminated
- Multiplexed transducers possible — up to 4 transducers/fiber loop
- Reduced cost
 - VCSEL Array \$200 versus demultiplexing receiver \$1500
- Reduced interface cost/sensed function of 20 to 30

Military standards

Military - Qualification requirements

need updating

for photonic components ??

Fiber-Optic Sensor Costs vs. Existing Sensors

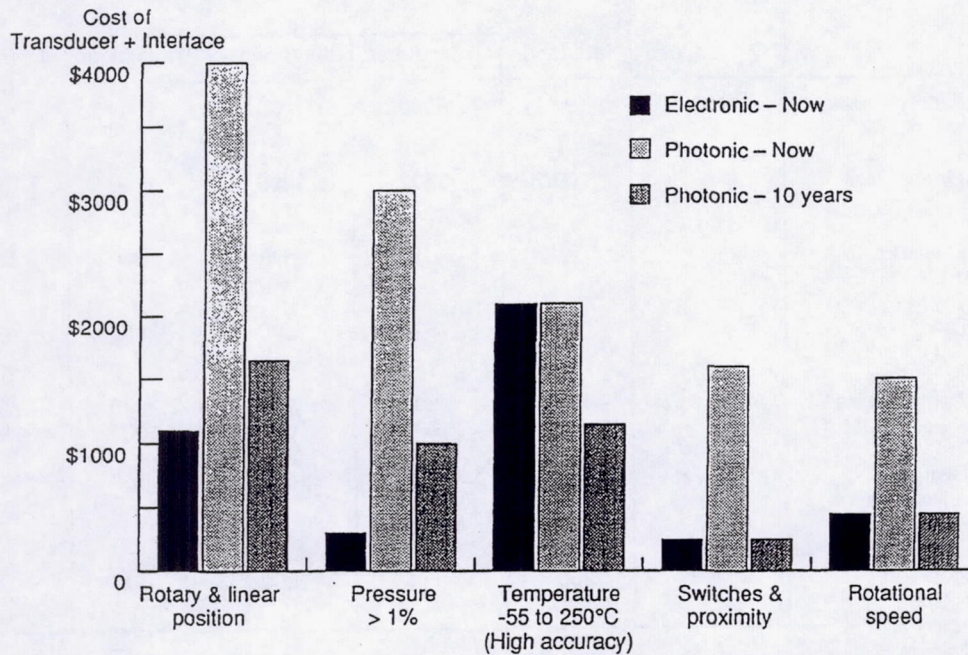

Road Map for Fiber-Optic Sensor Acceptance

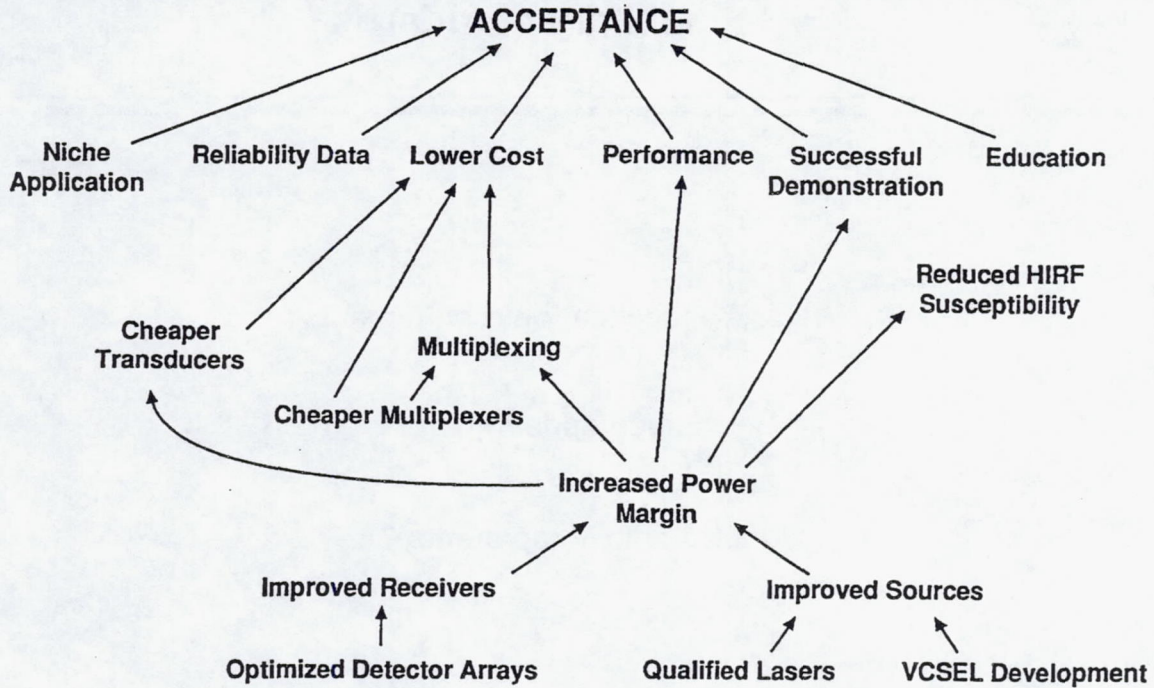

Fiber-Optic Sensor Costs vs. Existing Sensors

	Conventional Sensor		Fiber-Optic Sensors			
	Transducer	Interface	Now		10 Years	
			Transducer	Interface	Transducer	Interface
Rotary Position	1000	100	3000	1000 ¹	1500 ²	150 ²
Linear Position	1200	100	3500	1000 ¹	1500 ²	150 ²
Pressure (0.1%)	2500	—	NA	NA	NA	NA
Pressure (1%)	100	200	1500	1500	850	150 ²
Temperature ⁵ -55 to 250°C ⁶	2800 ³	700	2800 ³ 1500 ⁴	700 1000	2800 ³ 1000 ⁴	700 150 ²
Switches/ Proximity	100	150	100	1500	100	150 ²
Rotation Speed	250	200	500	1000 ¹	300	150 ²

1 - 1 board services 5 transducers
2 - 1 board services 10 transducers
3 - Sense element + housing

4 - Sense element only
5 - Vendor 1
6 - Vendor 2

Summary

- Cost**
- Not presently cost effective
 - High degree of multiplexing needed to reduce cost

Weight - Some weight savings

Optical power margin - potential improvement using two approaches

- Allows multiplexing
- Reduces transducer cost
- May reduce E/O interface complexity

HIRF susceptibility

- May be a problem
- Need tests on FO sensor interfaces

Program interest

- Must have obvious advantage or fill niche requirements

Components Session

Industry Chair: Gerard Walles, Sikorsky Aircraft
Government Coordinator: Jorge Sotomayor,
NASA Lewis Research Center

Interconnect Requirements for Aerospace Applications

Presenter: Gerard Walles, Sikorsky Aircraft

- Develop a consensus on research direction and define relationship between government and industry.
- Assist industry so it may compete with the global marketplace.
 - Global -- need bench market

FIBER OPTIC COMPONENTS WORK SESSION

- Amphenol
- Packard Hughes
- NASA Goddard Space Flight Center
- BF Goodrich Aerospace
- Naval Air Warfare Center
- USAF - Wright Patterson
- NASA Lewis Research Center
- Lear Astronics Corporation
- Naval Surface Warfare Center
- Allied Signal
- Sikorsky Aircraft

FIBER OPTIC COMPONENTS WORK SESSION

Participants:

- Amphenol
 - David Galluser
 - Richard Stenman
- Packard Hughes
 - Michael Orr
- NASA Goddard Space Flight Center
 - John Kolasinski
- BF Goodrich Aerospace
 - Gregory Urban
- Naval Air Warfare Center
 - John Herp
- USAF - Wright Patterson
 - Thomas Shaffer
- Lear Astronics Corporation
 - Javid Messian
- Naval Surface Warfare Center
 - Bill Riggs
- Allied Signal
 - Janpu Hou
- Sikorsky Aircraft
 - Gerard Walles
- NASA Lewis Research Center
 - Amy Jankovsky
 - Jorge Sotomayor

FIBER OPTIC COMPONENTS WORK SESSION

Key Issues:

- Standardization
- Market Solutions vs. Program Solutions
- Supportability of Inter-connection Technology
- Producibility - manufacturing concerns
- Technology Status - sharing of information
- Safety and cost (production status)
- Reliability Data - Lacking
- Performance Benefits
- Dual Use
- Sensors
 - harsh environment inter-connection hardware
- Marketing this Technology
- Training

FIBER OPTIC COMPONENTS

Areas for improvement - existing connectors:

- improve repeatability
- simplification of termination procedures
- no reliability data available
- connectors do not address contamination issues
- define rework - pin (ferrule) length
- lower insertion loss - PC
- lack of uniform connector test evaluation procedures
- high temperature connector - engine (>350 C)
- total cost
- producibility

FIBER OPTIC COMPONENTS WORK SESSION

List of recommendations:

1. Research funds/programs must have inter-connect technology as a line item:
 - a. request clear goals/objectives
 - b. system approach to interconnects
2. Research funding three areas (integrated funds):
 - a. F.O. cables
 - b. F.O. connectors
 - c. E/O & O/E components
3. Establish a F.O. Aerospace Inter-connection Council

FIBER OPTIC COMPONENTS WORK SESSION

Systems Approach to Interconnection Technology

- Performance
- Environmental
- Cost Evaluation
 - use existing hardware
- Supportability
 - maintainability/repair
 - testing (field)
 - manufacturing
- Concurrent Design Development Phase
 - designers
 - user
 - manufacturing
- Quality
- Training
- Address Standardization - other programs
- Components Evaluation Testing

FIBER OPTIC COMPONENTS GOVERNMENT FUNDING

Research Funding (20%)

- support US market leadership
- provide direction on next generation systems

Development Funding (80%)

- support US market - near term success (5 yrs)
- address user community - real problems
- support reliability data

VISION:

To support the maturity and wide use of FO technology in the Aerospace market, funds must be directed towards developmental efforts of interconnection technology.

FIBER OPTIC COMPONENTS WORK SESSION

Fiber Optic Aerospace Inter-Connection Council

- Primary goal
 - share information (R&D), during developmental stage
- Benefits:
 - reduce duplication of efforts
 - support dual use
 - promote standardization
 - reduce time to market
 - more user community visibility
 - other users: space, fixed wing, heli, engine
 - share lessons learned
 - strengthen US market

FIBER OPTIC COMPONENTS WORK SESSION

Questions:

1. Hybrid vs. non-hybrid connectors.
2. Common evaluation of interconnection components.
3. Do any of the upcoming system designs include components such as:
 - a. WDM
 - b. optical switches
 - c. wavelength flattened couplers
4. Can industry obtain information concerning past F.O. research programs (government funded):
 - a. players
 - b. program overview
 - c. reports (final)

FIBER OPTIC COMPONENTS

Address Component Support to Critical Systems

- Avionics:
 - 1773, NSDG, VDDN, ARINC, FDDI
 - Fly-by-Light Control - sensors
- Engine Control

APPENDIX--LIST OF ATTENDEES

Samuel R. Algera
Conax Buffalo Corporation
2300 Walden Avenue
Buffalo, NY 14225

Dr. Mark G. Allen
Physical Science Inc.
20 New England Business Center
Andover, MA 01810-1077

Marcelino G. Armendariz
Sandia National Laboratories
P.O. Box 5800
MS 0874
Albuquerque, NM 87185

Frank Banks
Banks Engineering & Labs
10633 Roselle Street
San Diego, CA 92121

Erwin W. (Erv) Baumann
McDonnell Douglas Aerospace
Mail Code 102-1310
P.O. Box 516
St. Louis, MO 63166-0516

Steven R. Boggs
NSWC Crane
Code 6021, Bldg. 2035
300 Highway 361
Crane, IN 47522-5001

Christopher M. Carlin
Boeing
MS 6H-FJ
P.O. Box 3707
Seattle, WA 90124

Kiyoung Chung
General Electric Aircraft Engines
One Neumann Way
MS G-57
Cincinnati, OH 45215-6301

Stephen W. Clausi
Rockwell International
Space Systems Division
12214 Lakewood Blvd., FC-47
Downey, CA 90241

Dr. Merritt N. Deeter
National Institute of Standards and Technology
325 Broadway, MS 815.03
Boulder, CO 80303-3328

Stephen M. Emo
Allied Signal Aerospace Co.
Bendix Engine Control Division
717 N. Bendix Drive
South Bend, IN 46620

Kimberly A. Ennix
NASA Dryden Flight Research Center
P.O. Box 273
MS 2033
Edwards, CA 93523-0273

Thomas C. Evatt
Rocketdyne Division, Rockwell Int'l Corporation
6633 Canoga Avenue
P.O. Box 7922
Canoga Park, CA 91309-7922

Christopher V. Fields
Pratt & Whitney
P.O. Box 109600, MS 731-67
West Palm Beach, FL 33401

David J. Fischer
Polymicro Technologies, Inc.
18019 N. 25th Avenue
Phoenix, AZ 85023

Israel Frisch
The Boeing Co.
P.O. Box 3707, MS 6H-FJ
Seattle, WA 98124

David O. Gallusser
Amphenol Aerospace Operations
40-60 Delaware Street
Sidney, NY 13838

Donald J. Halski
McDonnell Douglas
P.O. Box 516, MC 106-9020
St. Louis, MO 63166-0516

Sandy L. Harper
Parker Hannifin Corp.
Central Engineering
18321 Jamboree Road
Irvine, CA 92715

Dr. Robert J. Heaston
IIT Research Institute/GACIAC
10 West 35th Street
Chicago, IL 60616-3799
rheaston@dgis.dtic.dla.mil

John E. Herp
Naval Air Warfare Center
6000 E. 21 Street
Indianapolis, IN 46219-2189

Janpu Hou
Allied Signal Inc.
P.O. Box 1021
Morristown, NJ 07962

Raymond W. Huggins
Boeing Defense and Space Group
P.O. Box 3999
MS 3W-0S
Seattle, WA 98124-2499

Amy L. Jankovsky
NASA Lewis Research Center
21000 Brookpark Road, MS SPTD-2
Cleveland, OH 44135

Jeffers
McDermott Energy Services, Inc.
1562 Beeson St.
Alliance, OH 44601

John Kolasinski
NASA Goddard Space Flight Center
Code 733.2
Greenbelt, MD 20771

Amit Kulshreshtha
Lear Astronics
3400 Airport Avenue,
P.O. Box 442
Santa Monica, CA 90406-0442

Anthony A. Lambregts
Boeing Commercial Airplane Group
P.O. Box 3707, MS 19-HF
Seattle, WA 98124

Javid Messian
Lear Astronics Corporation
3400 Airport Avenue
Santa Monica, CA 90406-0442

Mark S. Miller
Rosemount Aerospace
14300 Judicial Road
Eagan, MN 55306

Marlan B. Modrow
Rockwell CCA
Government Aviation Division
400 Collins Road NE, MS 124-211
Cedar Rapids, IA 52498

Michael D. Orr
Packard-Hughes Interconnect
17150 Von Karman Ave., MS 040
Irvine, CA 92714

Richard L. Paul
BFGoodrich Aerospace, Simmonds Precision
Norwich Oxford Road
P.O. Box 310
Norwich, NY 13815

Charles R. Porter
Boeing Defense & Space Group
Box 3999, MS 3W-07
Seattle, WA 98124-2499

W. T. Powers
NASA Marshall Space Flight Center
Mail Stop EB22
Marshall Space Flight Center, AL 35812

William Ross Rapoport
Allied Signal
P.O. Box 1021, CTC-3
101 Columbia Road
Morristown, NJ 07962

Bill R. Riggs
Naval Surface Warfare Center (NSWC Crane)
Bldg. 2035, Code 6021
300 Highway 361
Crane, IN 47522

Bob Rubino
UTRC
411 Silver Lane
MS 129-92
East Hartford, CT 06108

Dr. Takeo Sawatari
Sentec Corp.
2000 Oakley Park Road, Suite 205
Walled Lake, MI 48390

Kenneth J. Semega
Wright Patterson AFB
Propulsion and Power Directorate
1950 Fifth Street, WL/POTA
Dayton, OH 45433

Gary Seng
NASA Lewis Research Center
21000 Brookpark Road, MS 11-3
Cleveland, OH 44135

Dr. Lawrence W. Shacklette
AlliedSignal, Inc.
P.O. Box 1021, CTC-3
101 Columbia Road
Morristown, NJ 07962-1021

Thomas W. Shaffer
U.S. Air Force
WL/POTA
1950 Fifth Street
WPAFB, OH 45433-7251

Stephen L. Shulman
FiberOptic Sensor Technologies
501 Avis Drive, Suite 5
Ann Arbor, MI 48108

William B. Spillman, Jr.
BFGoodrich
Panton Road
Vergennes, VT 05491

Don Stauffer
Honeywell Technology Center
10701 Lyndale Avenue, South
Bloomington, MN 55420

Richard G. Stenman
Amphenol Corporation
40-60 Delaware Avenue
Sidney, NY 13838-1395

Daniel B. Thompson
USAF Wright Laboratory
2210 Eighth St., Suite 11
Wright Patterson Air Force Base, OH 45433-7521

John R. Todd
Douglas Aircraft
MC 36-48
3855 Lakewood Blvd.
Long Beach, CA 90846

Gregory L. Urban
BF Goodrich Aerospace (Simmonds Precision)
Engine Electrical Systems Division
Norwich Oxford Road
P.O. Box 310
Norwich, NY 13815

Gerard Walles
Sikorsky Aircraft
6900 Main Street, MS Z102A
Stratford, CT 06601-1381

Willes H. Weber
Ford Motor Corporation
Physics Department
MD 3028/SRL
Dearborn, MI 48121-2053

Joseph Wilgus
Wright Patterson Air Force Base
WL/AAAS-1
2185 Avionics Circle
Wright-Patterson AFB, OH 45433-7301

Paul Wren
BFGoodrich Aerospace
Military Fuel and Integrated Systems
5030 Castleview Court
Huber Hts., OH 45424

Eddie Zavala
NASA Dryden Flight Research Center
P.O. Box 273, MS 4840D
Edwards, CA 93523

REPORT DOCUMENTATION PAGEForm Approved
OMB No. 0704-0188

Public reporting burden for this collection of information is estimated to average 1 hour per response, including the time for reviewing instructions, searching existing data sources, gathering and maintaining the data needed, and completing and reviewing the collection of information. Send comments regarding this burden estimate or any other aspect of this collection of information, including suggestions for reducing this burden, to Washington Headquarters Services, Directorate for Information Operations and Reports, 1215 Jefferson Davis Highway, Suite 1204, Arlington, VA 22202-4302, and to the Office of Management and Budget, Paperwork Reduction Project (0704-0188), Washington, DC 20503.

1. AGENCY USE ONLY (Leave blank)		2. REPORT DATE February 1995	3. REPORT TYPE AND DATES COVERED Conference Publication	
4. TITLE AND SUBTITLE 1994 Fiber Optic Sensors for Aerospace Technology (FOSAT) Workshop			5. FUNDING NUMBERS WU-505-60-00	
6. AUTHOR(S) Robert Baumbick, Grigory Adamovsky, Meg Tuma, Glenn Beheim, and Jorge Sotomayor, compilers				
7. PERFORMING ORGANIZATION NAME(S) AND ADDRESS(ES) National Aeronautics and Space Administration Lewis Research Center Cleveland, Ohio 44135-3191			8. PERFORMING ORGANIZATION REPORT NUMBER E-9426	
9. SPONSORING/MONITORING AGENCY NAME(S) AND ADDRESS(ES) National Aeronautics and Space Administration Washington, D.C. 20546-0001			10. SPONSORING/MONITORING AGENCY REPORT NUMBER NASA CP-10166	
11. SUPPLEMENTARY NOTES This report is a compilation of presentations at the 1994 Fiber Optic Sensors for Aerospace Technology (FOSAT) Workshop sponsored by the NASA Lewis Research Center, Cleveland, Ohio, October 18-20, 1994. Responsible person, Robert Baumbick, organization code 2540, (216) 433-3735.				
12a. DISTRIBUTION/AVAILABILITY STATEMENT Unclassified - Unlimited Subject Categories 01 and 06 This publication is available from the NASA Center for Aerospace Information, (301) 621-0390.			12b. DISTRIBUTION CODE	
13. ABSTRACT (Maximum 200 words) The NASA Lewis Research Center conducted a workshop on fiber optic technology on October 18-20, 1994. The workshop objective was to discuss the future direction of fiber optics and optical sensor research, especially in the aerospace arena. The workshop was separated into four sections: a Systems Section which dealt specifically with top level overall architectures for the aircraft and engine; a Subsystems Section considered the parts and pieces that made up subsystems of the overall systems; a Sensors/Actuators Section considered the status of research on passive optical sensors and optical powered actuators; and, a Components Section which addressed the interconnects for the optical systems (e.g., optical connectors, optical fibers, etc.). This report contains the minutes of the discussion on the workshop, both in each section and in the plenary sessions. The slides used by a limited number of presenters are also included as presented. No attempt was made to homogenize this report. The view of most of the attendees was: (a) the government must do a better job of disseminating technical information in a more timely fashion, (b) enough work has been done on the components, and system level architecture definition must dictate what work should be done on components, (c) a Photonics Steering Committee should be formed to coordinate the efforts of government and industry in the Photonics area, to make sure that programs complimented each other and that technology transferred from one program was used in other programs to the best advantage of the government and industry.				
14. SUBJECT TERMS Fiber optics; Optical sensors; Photonics; Fly-by-light			15. NUMBER OF PAGES 90	
			16. PRICE CODE A05	
17. SECURITY CLASSIFICATION OF REPORT Unclassified	18. SECURITY CLASSIFICATION OF THIS PAGE Unclassified	19. SECURITY CLASSIFICATION OF ABSTRACT Unclassified	20. LIMITATION OF ABSTRACT	