

1995120372

N95- 26792

50 Ah NiH₂ CPV Qualification Tests
J.C. Garner, W. Barnes, G. Hickman
U.S. Naval Research Laboratory

In 1992, the Naval Research Laboratory (NRL) started a program to qualify a large diameter common pressure vessel (CPV) nickel hydrogen (NiH₂) batteries for use on future Navy/NRL spacecraft electrical power subsystems. NRL's involvement with the qualification of CPV NiH₂ batteries dates back to 1988 when COMSAT and Johnson Controls Inc., initiated a joint effort to fly the first ever NiH₂ CPV in space. A later NRL-JCI cooperative research and development agreement led to the launch of a space experiment in 1993 and to the use of a single NiH₂ CPV battery on the BMDO Clementine spacecraft in 1994. NRL initiated procurement of two, 50 Ah CPV NiH₂ batteries in the Fall of 1992. The two batteries were delivered to NRL in June 1994. NiH₂ CPV batteries have almost 2x the specific energy (Wh/kg) of nickel cadmium batteries and 2x the energy density (Wh/l) of individual pressure vessel NiH₂ CPV's. This presentation discusses the results of electrical and mechanical qualification tests conducted at NRL. The tests included electrical characterization, standard capacity, random vibration, peak load, and thermal vacuum. The last slides of the presentation show initial results from the life cycle tests of the second NiH₂ CPV battery at 40% depth of discharge and a temperature of 10 deg Celsius.

ENCLOSING PAGE BLANK NOT FILMED

50Ah NiH₂ CPV Qualification Tests

**J.C. Garner, W. Barnes, G. Hickman
U.S. Naval Research Laboratory
Washington, D.C. 20375-5354**

INTRODUCTION

- **Discuss Preliminary Qualification Test Results Conducted On Eagle Picher (Johnson Controls Inc.) 50 Ah NiH₂ CPV Batteries**
- **Discuss Follow On Work With 50 Ah NiH₂ CPV**
- **Additional NiH₂ CPV Work @ NRL**

Purpose

- Risk Reduction Effort To Qualify The 50 Ah Common or Single Pressure Vessel Battery For Use In Future Navy/NRL Spacecraft

50 Ah CPV Advantages

	<u>110 Ah IPV NiH₂</u>	<u>50 Ah CPV NiH₂</u>
Number Of Batteries	1	2
Cells/Battery	24	22
Bare Battery Mass	141.36 lbs	126 (63 lbs/Bat)
Mechanical/Thermal Mounting Hardware	70.68 lbs	25.2 lbs
Total Battery Mass	212.04 lbs	151.20 lbs
Mass Savings		60.84 lbs

50 Ah CPV Mechanical/Thermal Spacecraft Interface

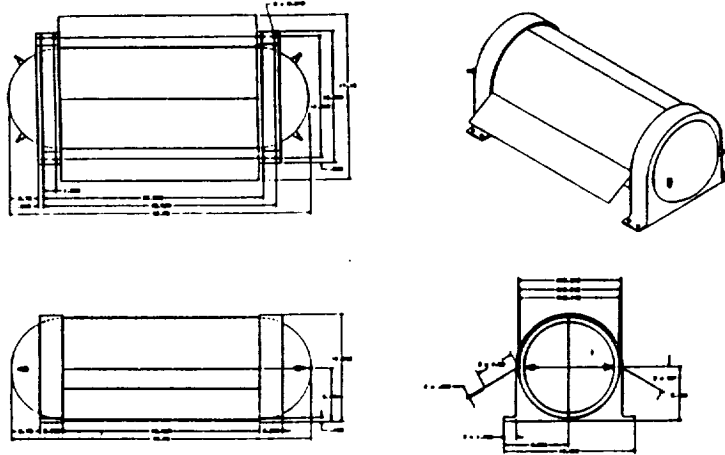

Program Schedule

- 1992 September - Released Procurement Package
- 1993 January - Awarded Contract To Johnson Controls Inc., For Two (2) 50 Ah NiH₂ CPV Batteries
- 1993 February - Preliminary Design Review
- 1993 April NRL Preliminary Design Review
- 1993 August - Critical Design Review
- 1993 August - December
 - Pressure Vessel Qualification
 - Cell Build
 - Electrolyte Fill Determination Tests
- 1994 January - March End Plate Problems
 - Complete Mass Simulator, Conduct Qualification Vibration
- 1994 March - June Assemble Batteries/Acceptance Test
- 1994 July - September Qualification Tests On S/N 144
- 1994 September Start Life Cycle Test S/N 145

**Eagle Picher (Johnson Controls Inc.)
50 Ah NiH₂ CPV Battery**

- Capacity 50 Ampere-Hours*
- Number Of Cells 22
- Back-To-Back Positive Electrodes
- Separator Dual Layer Zircar
- Electrolyte 31% KOH
- Pressure Vessel 30 mil Inconel 718 Tube w/
Hydroformed End Domes
 - Diameter 10.0 inches
 - Length 30.0 inches
- Mass 63 lbs (28.58 kg)
- Terminal Positive, Negative, 1/2 Battery Voltage
- Pressure Kuhlite ETM-341-375-1000 Pressure Transducer

* When Discharged @ C/2=25.0 Amps To 22.0 Volts @ 10°C, After A 16 Hour Charge @ C/10=5.0 Amps

Battery Exterior Dimensions

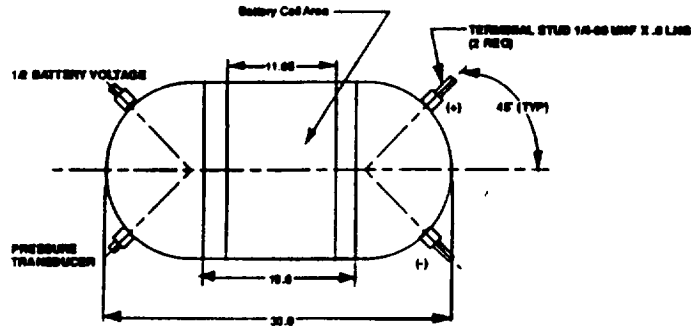

---NOTE---
1) VESSEL WALL .031"
2) VESSEL O.D. 10.112± .004

Electrolyte Fill Level Tests (1 Of 2)

- **Earlier Experience W/Clementine Batteries Showed Oxygen Recombination Damage (Popping) To Electrolyte Containment Bags Will Occur W/Too Much Electrolyte**
 - Cell Stack Must Be Removed From Pressure Vessel
 - Electrolyte Containment Bags Need Replacement
- **Electrolyte Fill Level Determined By Calculation**
 - Based On Nominal Component Dimensions
 - Assumes Vendors Supply Components Within Tolerance Specification
- **Per NRL Request, EP (JCI) Initiated Electrolyte Fill Level Tests Before Adding Electrolyte To First Battery**
 - EP Performed Electrolyte Fill Calculation (g/Ah)
 - Build 6 Boilerplate Test Cells, Sim-LEO Cycle
 - » 1. 2.9 g/Ah 4. 3.5 g/Ah
 - » 2. 3.0 g/Ah 5. 3.8 g/Ah (*calculated*)
 - » 3. 3.4 g/Ah 6. 4.0 g/Ah

Electrolyte Fill Level Tests (2 Of 2)

- **Capacity Measurement After 24 Cycles**
 - 2.9 g/Ah 10.50 Ah
 - 3.0 g/Ah 12.96 Ah
 - 3.4 g/Ah 11.68 Ah
 - 3.5 g/Ah 13.11 Ah
 - 3.8 g/Ah 13.04 Ah
 - 4.0 g/Ah 13.40 Ah
- **Continued Cycling the 3.0 g/Ah, 3.5 g/Ah, and 3.8 g/Ah**
- **1000 Cycle Capacity**
 - 3.0 g/Ah
 - 3.5 g/Ah
 - 3.8 g/Ah
- **Selected 3.65 g/Ah For Electrolyte Fill Level**

Pressure Vessel Qualification

- **Qualify Battery Pressure Vessel To MIL-STD-1522A**
- **Pressure Cycle Vessel From 0 To MEOP* For 4 x Expected Cycle Life**
 - 0 to 700 psi
 - 4 x 25,000 Cycles = 100,000 Cycles
- **Provide Safety Factor > 2.5 :1 For Burst**
- **Tests Conducted At Milwaukee School Of Engineering (FPI)**
- **3 Vessels Failed Before Successful Cycle Test**
 - Design Of Support For Cell Stack
 - Design Of Weld Ring
 - Shape Of Pressure Cycle Curve
- **Burst Pressure of 2320 psi After 105,000 Cycles**
 - Safety Factor 3.3 : 1

Eagle Picher (JCI) Acceptance Tests

- **Visual Inspection Dimensional and Weight Check**
- **Insulation Resistance Test**
- **Conditioning Capacity**
- **Capacity & Overcharge @ 25°C**
- **Capacity & Overcharge @ 35°C (Deleted)**
- **Capacity & Overcharge @ 0°C**
- **Impedance**
- **Charged Open Circuit Stand**
- **Electrolyte Leakage**
- **Pressure Transducer Calibration**

NRL Acceptance Test Plan

- Receipt & Inspection
- Installation Of Thermal Control Hardware
- Initial Capacity
 - 5.0 Amp Charge For 10 Hours + 2.5 Amp Charge For 14 Hours
 - -25 Amp Discharge to 22.0 Volts
- Capacity @ -10°C, -5°C, 0°C, 5°C, 10°C, 20°C
- LEO Cycle 40% DOD, 10°C
- Charge Retention Test
 - 5.0 Amp Charge 16 Hours, 72 Hours Open Circuit, -25 Amp Discharge To 22.0 Volts
- Peak Load Test
 - -25 Amp Discharge For 1 Hour Followed By -100 Amp Discharge For 5 Minutes
- Random Vibration
 - -10 Amp Discharge, 18.9 Grms For 180 Seconds In Each Axis
- Thermal Vacuum

5.0 Amp Charge For 16 Hours @ 5°C

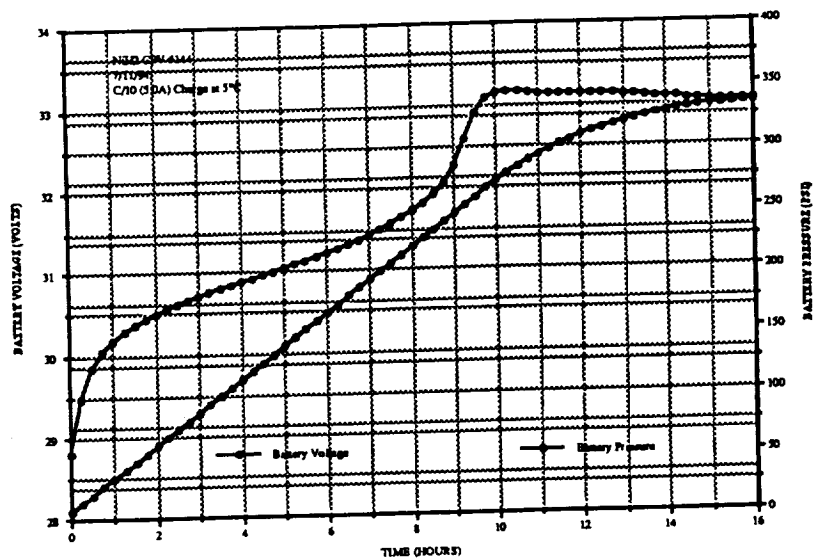

-25.0 Amp Discharge @ 10°C

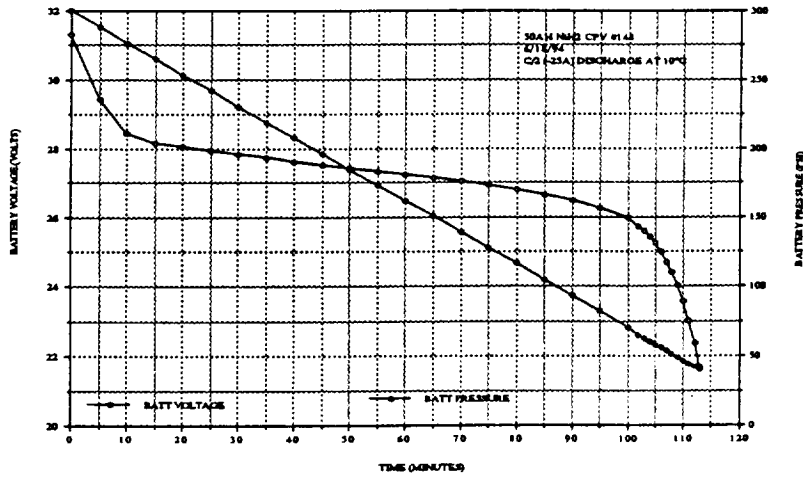

5.0 Amp Charge For 16 Hours @ -10°C

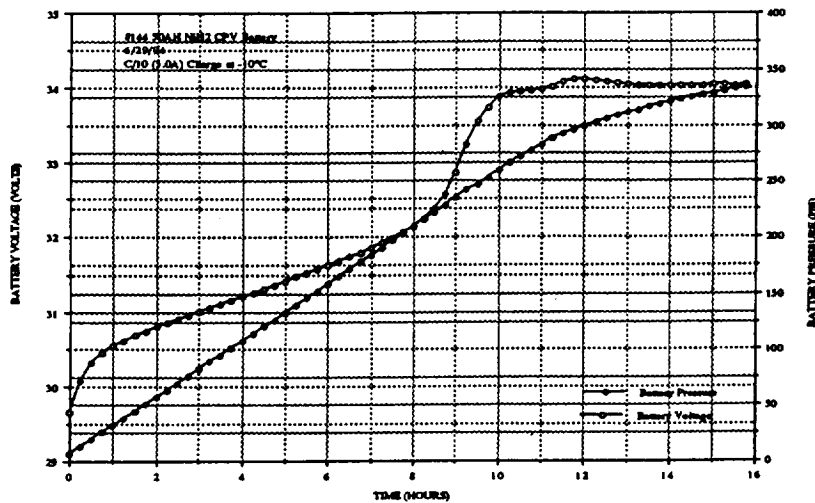

ORIGINAL PAGE IS
OF POOR QUALITY

-25.0 Amp Discharge @ -10°C

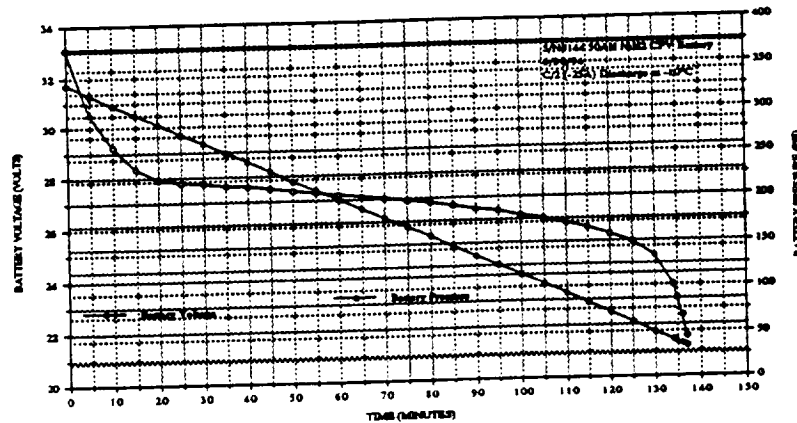

Random Vibration Test Levels

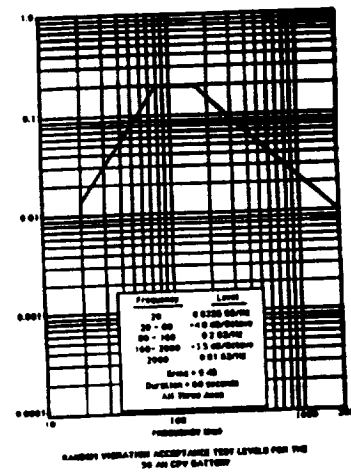
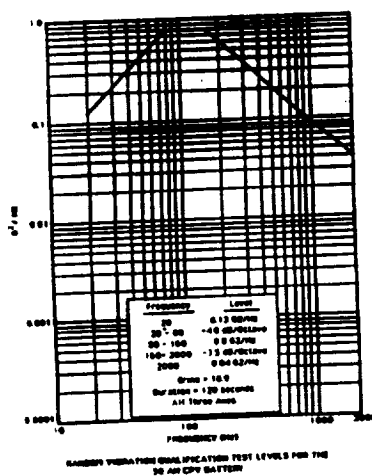

Post Vibration Peak Load Test

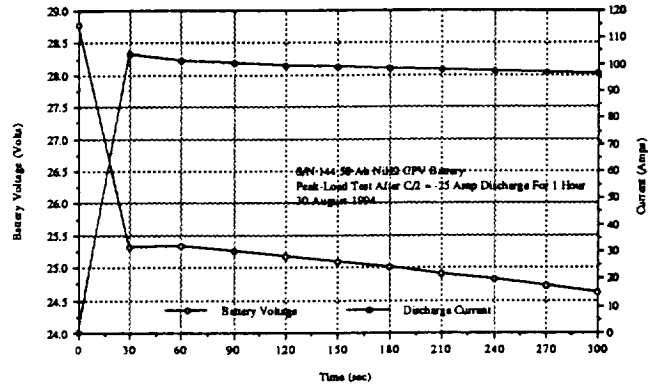

S/N 145 Life Cycle Test 40% DOD @ 10°C (EODV)

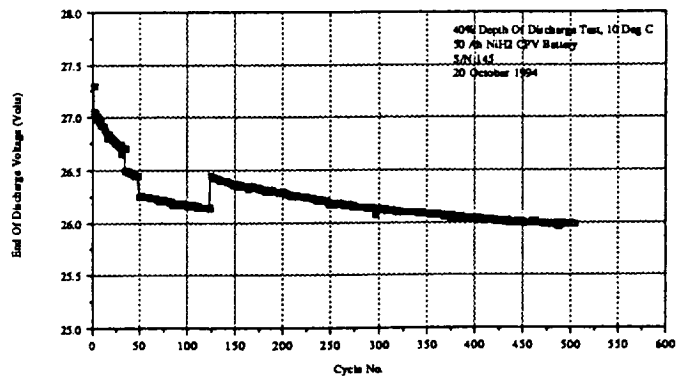

S/N 145 Life Cycle Test 40% DOD @ 10°C (EODP)

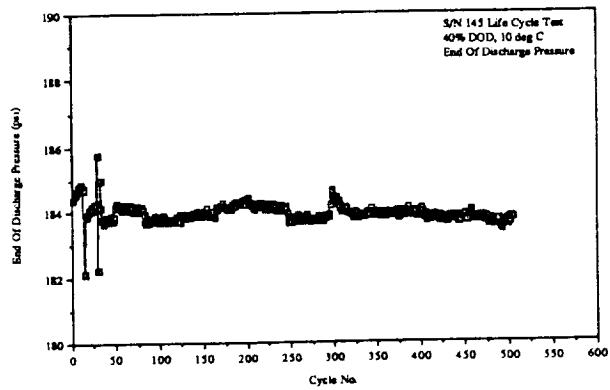

Qualification Test Program Status

- S/N 144 Completed All Environmental Tests
 - Life Cycle Test @ 60% DOD, 0°C
- Qualification Test Report In Progress
- S/N 145 Continue On Life Cycle Test, 40% DOD @10°C

Other NiH₂ SPV Work At NRL

- **S/N 144 To Be Returned To EP (Milwaukee) For Partial DPA & Thermocouple Instrumentation**
- **Thermal Design Verification Tests w/S/N 144 Planned**
- **Qual Flight Experiment Battery (10.5 Ah NiH₂ SPV) Life Cycle Tests Continues (+8500 Cycles)**
- **Clementine Qual & Flight Spare Batteries To Be Returned To EP (Milwaukee) For Partial DPA**
 - **NRL Receive Qual For Life Cycle Test**
 - **USAF PL Receives Flt Spare For Test @ NWSC Crane**
- **Procurement Of EP(Joplin) 50Ah SPV In Progress For Qualification Test**

