

7-28

51369

**"UTILIZATION OF COMPOSITE MATERIALS BY THE U.S. ARMY ---  
A LOOK AHEAD"**

PRESENTATION TO NINTH DOD/NASA/FAA CONFERENCE  
ON  
FIBROUS COMPOSITES IN STRUCTURAL DESIGN

RICHARD CHAIT

It is a pleasure to be with you today to give you some details of the United States Army's Composite Materials Program. My talk is entitled "Utilization of Composite Materials by the U.S. Army ... A Look Ahead." (VG #1)

The message I would like to leave with you is that the Army is very serious about the application of composite materials as it moves to become more and more of a high-tech Army. The value of delivering the right technology at the right time and at an affordable price (VG #2) certainly was brought home during the Gulf Crisis. Prior to detailing the Army's program on composite materials by commodity or mission areas, I would first like to show how composite materials fits into technology planning efforts. I will also cover important efforts to document design allowable information, supporting research, and some notional applications for composite materials. This outline provides the chronological order for the various sections of the talk (VG #3).

Regarding technology planning, the Army has several active efforts, e.g. Tech Base Master Plan (VG #4-6) and the Strategic Technologies for the Army or STAR Study that the National Academy of Sciences has undertaken (VG #7-8). In both instances the importance of advanced materials and particularly composite materials is seen.

One can look at the use of composite materials by commodity or mission area (VG #9). Let's start first by looking at the most important system in the U.S. Army, The Soldier.

**SOLDIER** -- Today, Kevlar fiber plays a significant role in both vests and helmets used for ballistic protection (VG #10-11). Tomorrow's helmet may be even stronger and lighter with the use of newer fibers such as the SPECTRA 900 fiber (VG #12-13).

**GROUND VEHICLES** -- Most recognize the Bradley Fighting Vehicle but what is different about this demonstration vehicle is the hull - it is made of fiberglass composite (VG #14-15). Advantages are numerous (VG #16). Plans call for this technology to be utilized in the fabrication of another hull, this time for a heavier vehicle, in the 50-55 ton range (VG #17-18). Other applications of composite

**PRECEDING PAGE BLANK NOT FILMED**

materials for ground vehicles are the M1A1 driver's seat (VG #19), road wheels (VG #20), turbine engine air plenum assembly (VG #21), power pack container (VG #22), various components of the 5-ton truck (VG #23), bridging (VG #24) and tanker applications (VG #25).

**AIRCRAFT** -- The use of composite materials is most noteworthy in Army aviation. The full potential of composite materials is realized in the recently awarded LH Comanche RAH-66 program (VG #26). Intense prior planning involved in the Army Modernization Program has paid off handsomely. Technology development such as in the Advanced Composite Airframes Program, played a major role in the LH Program (VG #27). Use of composites in the Comanche is covered in full detail (VG #28-30). It should be noted that a strong in-house research and development capability contributed significantly to the application of composites of Army aircraft (VG #32-33).

**MISSILES AND MUNITIONS** -- The use of composite materials for application to rocket motor uses, wings, fins and casings is under development (VG #34-36).

Important to the use of composite materials is the ability to obtain and document properties important to design. The Army has been very active in the MIL-HDBK-17 effort to formulate the basis for obtaining design allowable data of important composite materials. Various working groups stress the importance of standardizing mechanical tests, statistical analysis and chemical characterization (VG #37). Three volumes of MIL-HDBK-17 (VG #38) present the guidelines, the data and utilization of the data of various important materials (VG #39).

Complimenting the Army's in-house research to support much of the above developmental work is the effort of the Army Research Office's University Research Initiative program. For example, the URI program at the University of Delaware, developing 2-D cure simulation analysis to predict temperature and degree of cure within given cross-sections (VG #40 & 41), was important to the processing of thick section composite materials for ground vehicle hull application. In addition to awarding graduate fellowships and conducting workshops or symposia (VG #42), the University of Delaware conducts other programs in the area of composite material processing (VG #43-46). Single investigator programs (VG #47), funded by ARO, also contribute significantly to the composite materials knowledge base. Looking into the future for notional applications, one could visualize smart composite materials that would control vibrations in Army Aircraft (VG #48-50).

To summarize (VG #51), composite materials are an important segment of the Army's research, development, and engineering picture. Because of the diverse Army mission, composite materials may find application in any number of mission areas. Because of the uncertain funding profile, it is more important than ever that technology planning provide the basis for effective prioritization and leveraging of the tech base efforts involving advanced materials.

U.S. ARMY



MATERIEL COMMAND

Ninth DOD/NASA/FAA Conference  
On  
FIBROUS COMPOSITES IN STRUCTURAL DESIGN  
November 4 - 7, 1991

**UTILIZATION OF COMPOSITE MATERIALS  
BY THE U.S. ARMY  
... A LOOK AHEAD**

Dr. Richard Chait  
Chief Scientist  
U.S. Army Materiel Command

VG #1

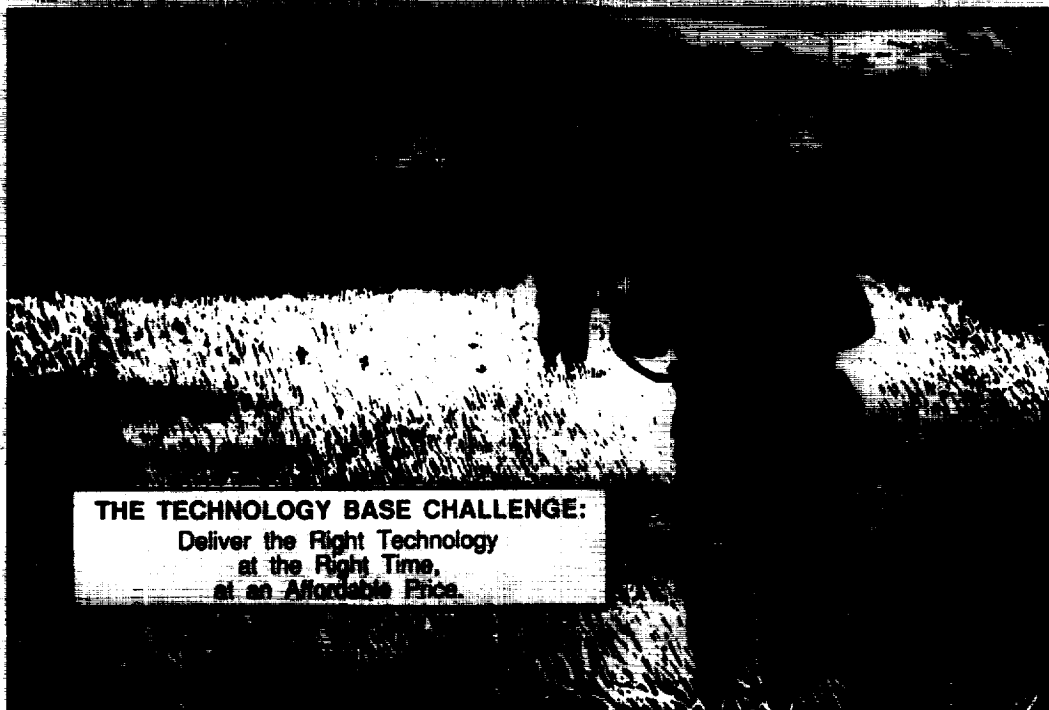

**THE TECHNOLOGY BASE CHALLENGE:**  
Deliver the Right Technology  
at the Right Time,  
at an Affordable Price.

VG #2



## OUTLINE

- I. Introductory Comments
- II. Mission Area Utilization
- III. Design Allowable Handbook
- IV. Supporting Research
- V. Future Concepts
- VI. Concluding Comments

VG #3

## ARMY TECHNOLOGY BASE MASTER PLAN

---

- TECHNOLOGY BASE INVESTMENT STRATEGY
- RESEARCH AND DEVELOPMENT BALANCE
- FOCUS ON CRITICAL/KEY EMERGING TECHNOLOGIES
- SPEEDING TECHNOLOGY TRANSITION
- LEVERAGING SCIENCE AND TECHNOLOGY OUTSIDE THE ARMY
- QUALITY SCIENTISTS AND ENGINEERS

**SCIENCE AND TECHNOLOGY SUPERIORITY:  
OUR INVESTMENT IN SHAPING THE FUTURE  
AND COMPETING SUCCESSFULLY**

VG #4

# TECHNOLOGY BASE MASTER PLAN

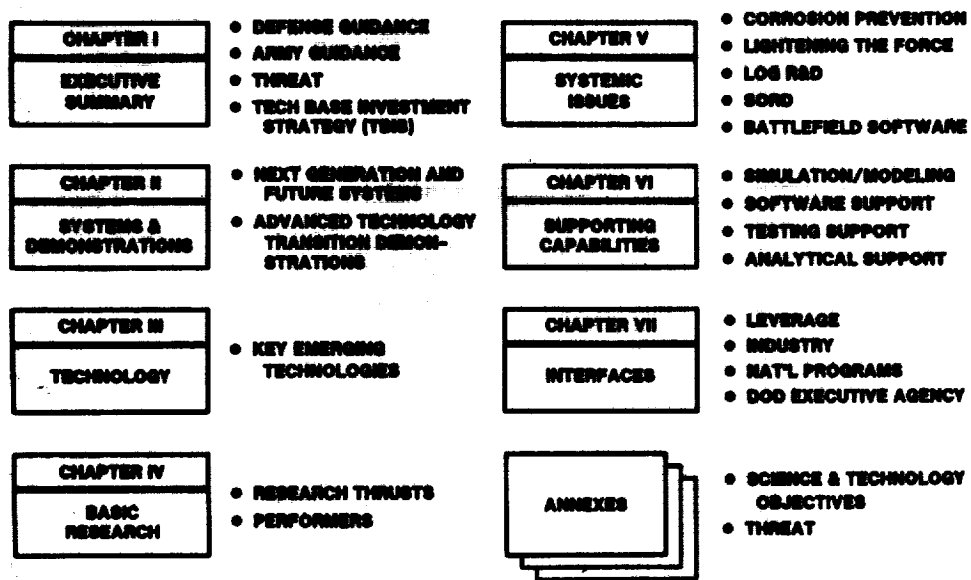

VG #5

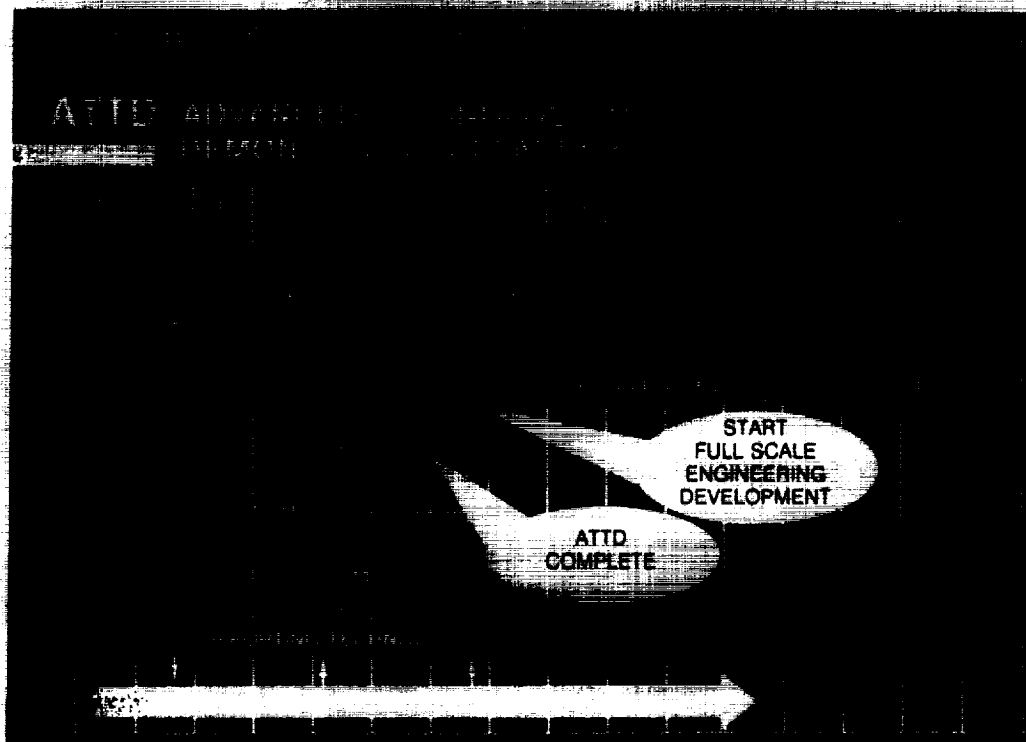

VG #6



US ARMY MATERIEL COMMAND  
OFFICE OF THE CHIEF SCIENTIST

An Independent Adviser to the Army:

## THE BAST

By Mark Bello

### Introduction

Advice is not a rare commodity, especially in the nation's capital. The value and usefulness of a specific piece of advice, however, are determined not by its availability, but rather by the quality of its content.

The main criteria used to judge the quality of advice are the expertise, integrity, and objectivity of the members of an advisory body. High levels of each of these standards are reflected in the composition and activities of the Board on Army Science and Technology (BAST).

A unit of the National Research Council, the service arm of the National Academies of Science and Engineering, and the Institute of Medicine, the BAST was formed in 1982 at the request of

used in weapons systems; and evaluated the adequacy of the Army's research and development programs on explosives, propellants, and other energetic materials. Ongoing studies include a continuing review of the congressionally mandated program to dispose of chemical stockpiles by 1994 and a far-reaching assessment that will forecast the strategic technologies critical to ground warfare in the 21st century.

### Historical Overview

The BAST's parent organization, the National Research Council and the National Academy of Sciences, were spawned, in part, by the exigencies of war. Congress created the academy

James B. Aulthouse, recently retired under secretary of the Army, since then, the independent board, whose members represent a broad range of scientific and engineering expertise, has been called on to study a variety of scientific, technological, and manpower issues confronting the Army.

For example, the BAST completed a forecast of the Army's needs for scientists, engineers, and technical personnel through the end of the century, assessed the relative implications of its changing base on foreign suppliers of electronic components

We need to think beyond the year 2000.

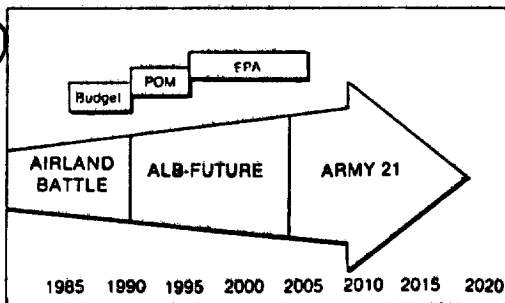

AMC

VG #7



## STAR STUDY ORGANIZATION

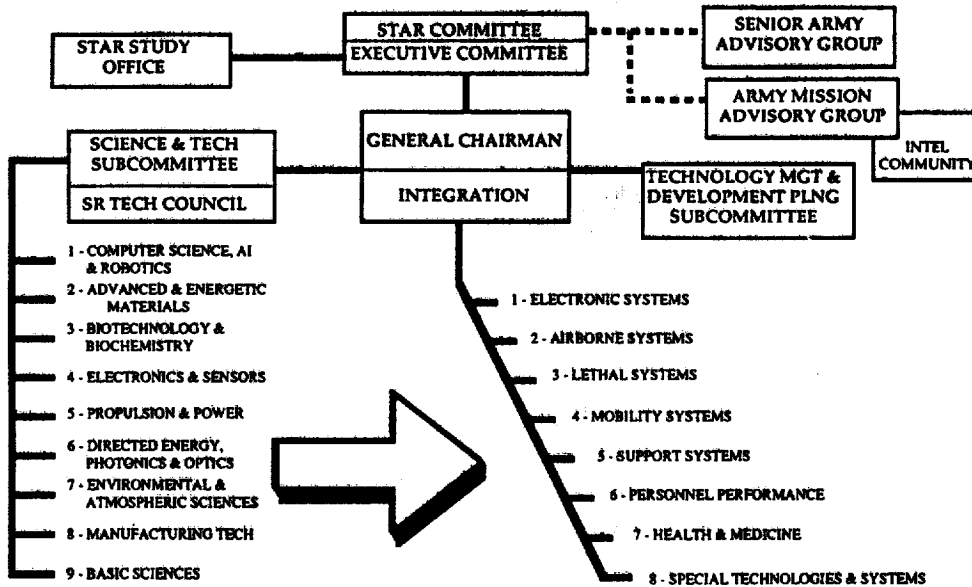

U.S. ARMY MATERIEL COMMAND  
OFFICE OF THE CHIEF SCIENTIST

VG #8

# LIGHTENING THE FORCE

ARO

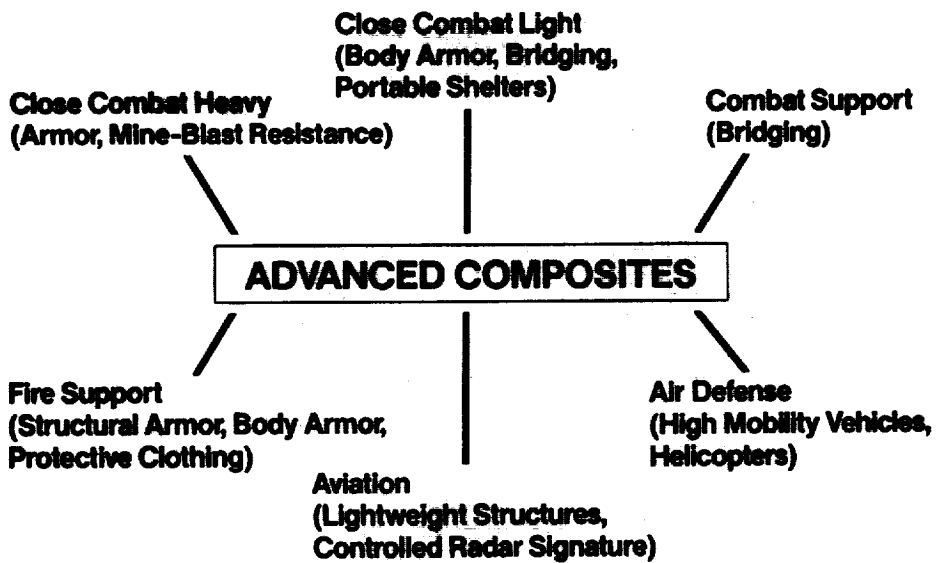

VG #9



VG #10



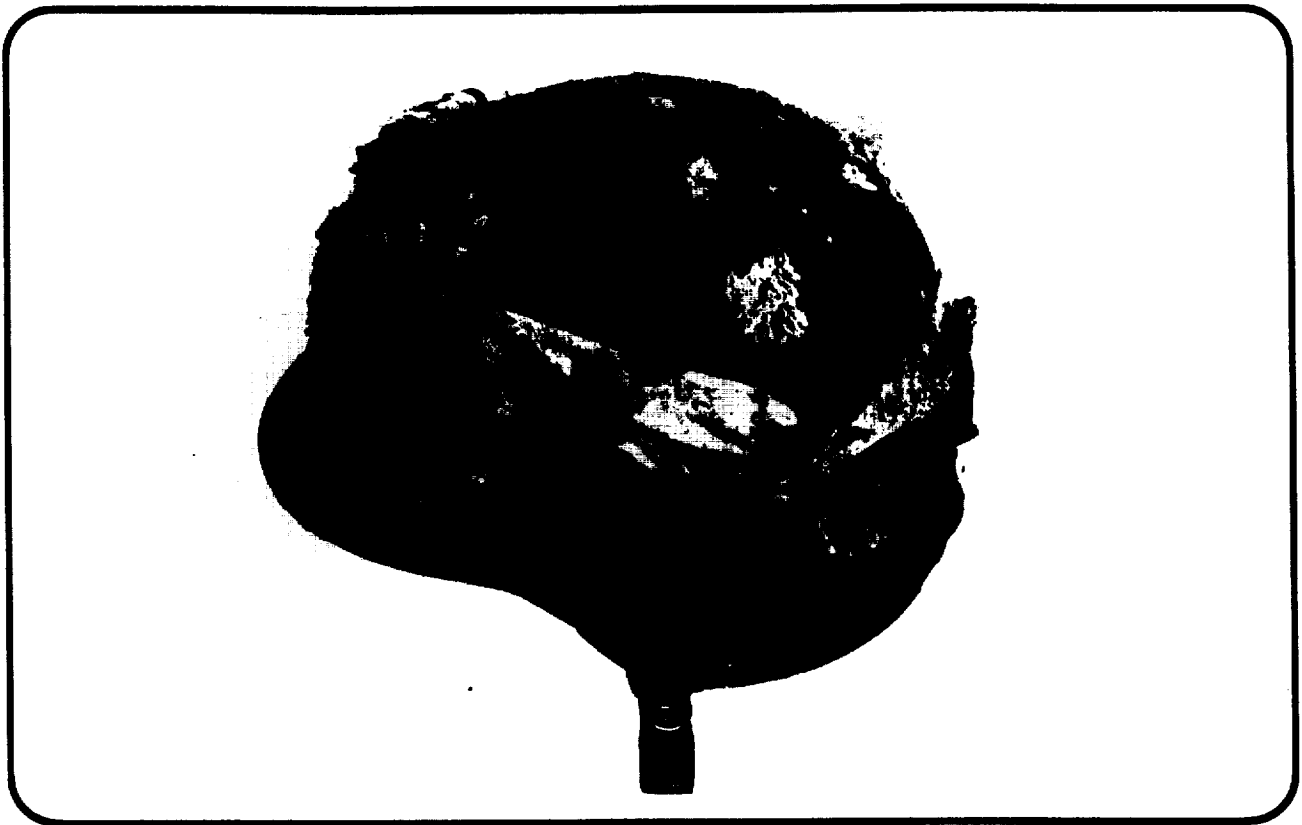

VG #11

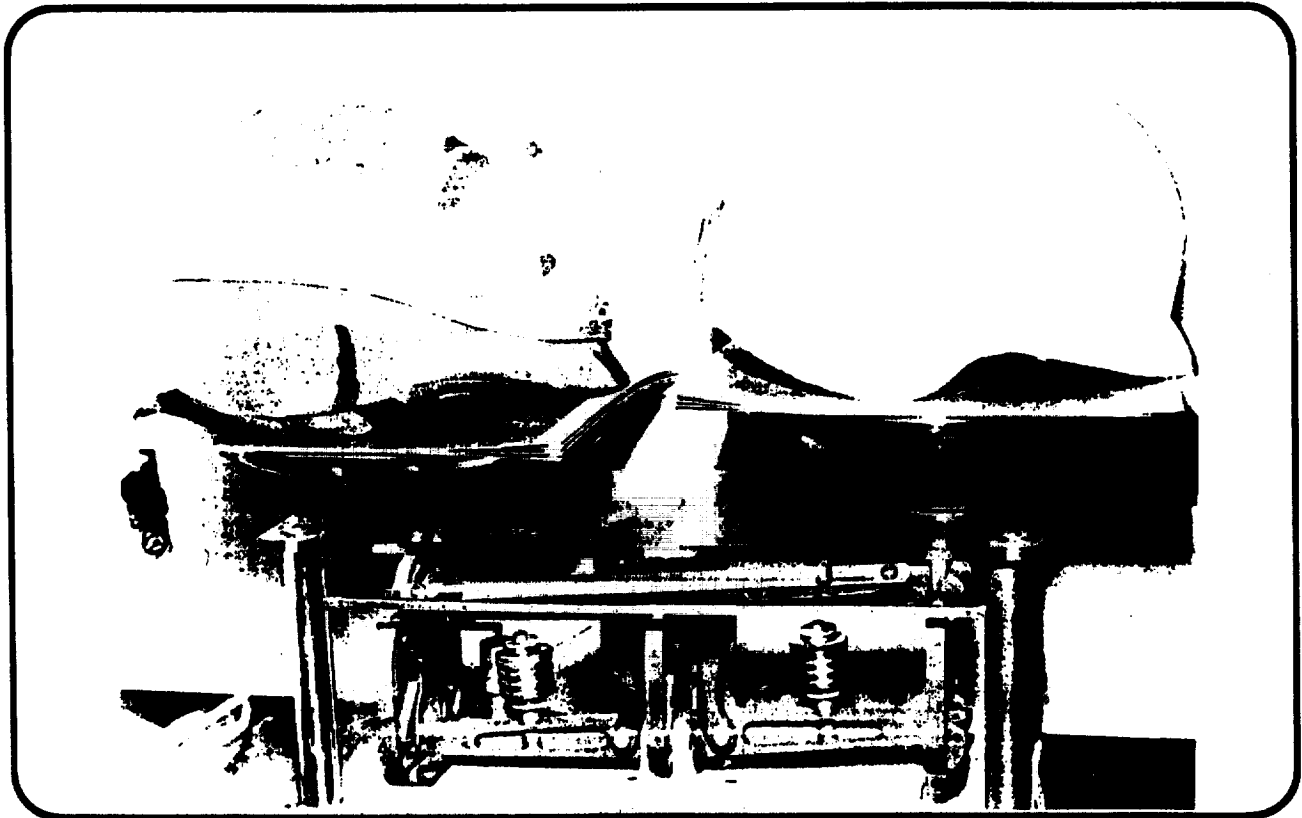

VG #12

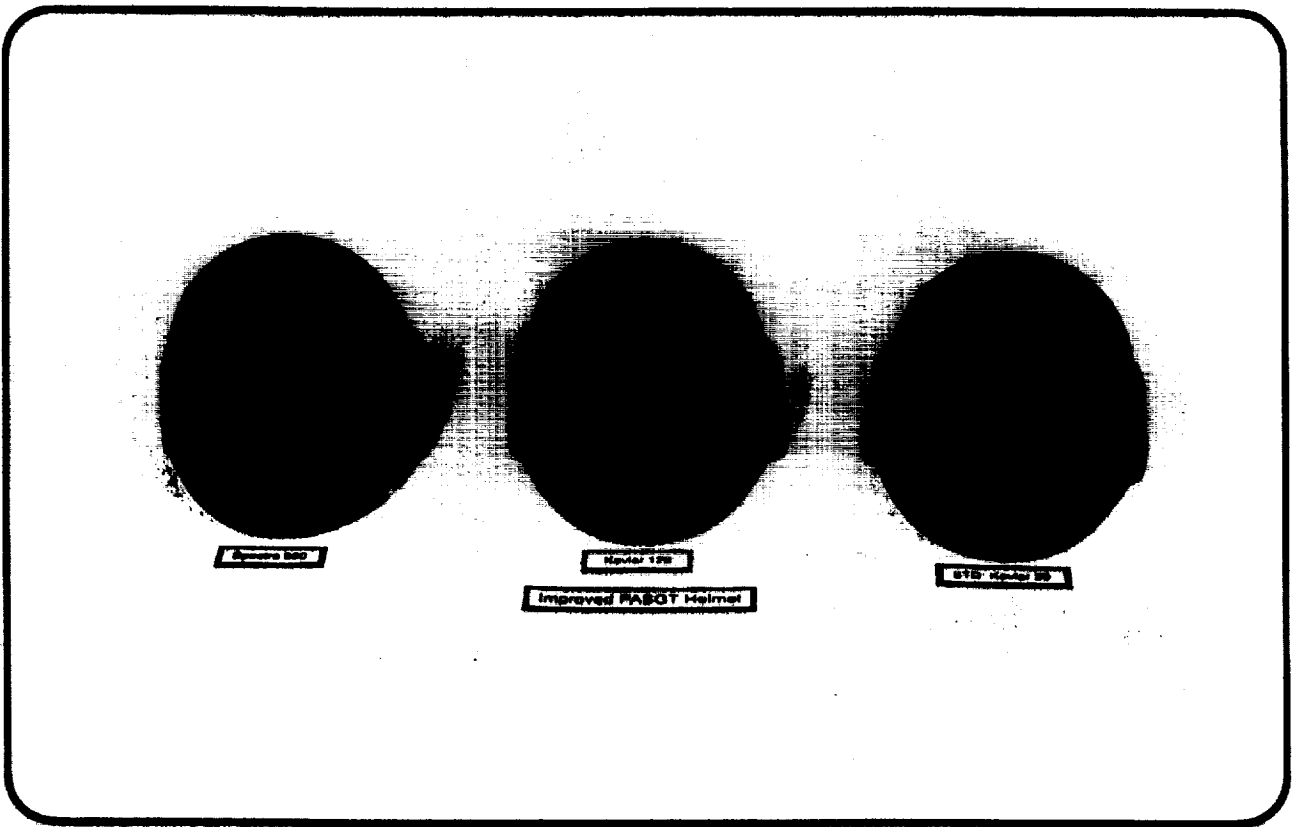



VG #13

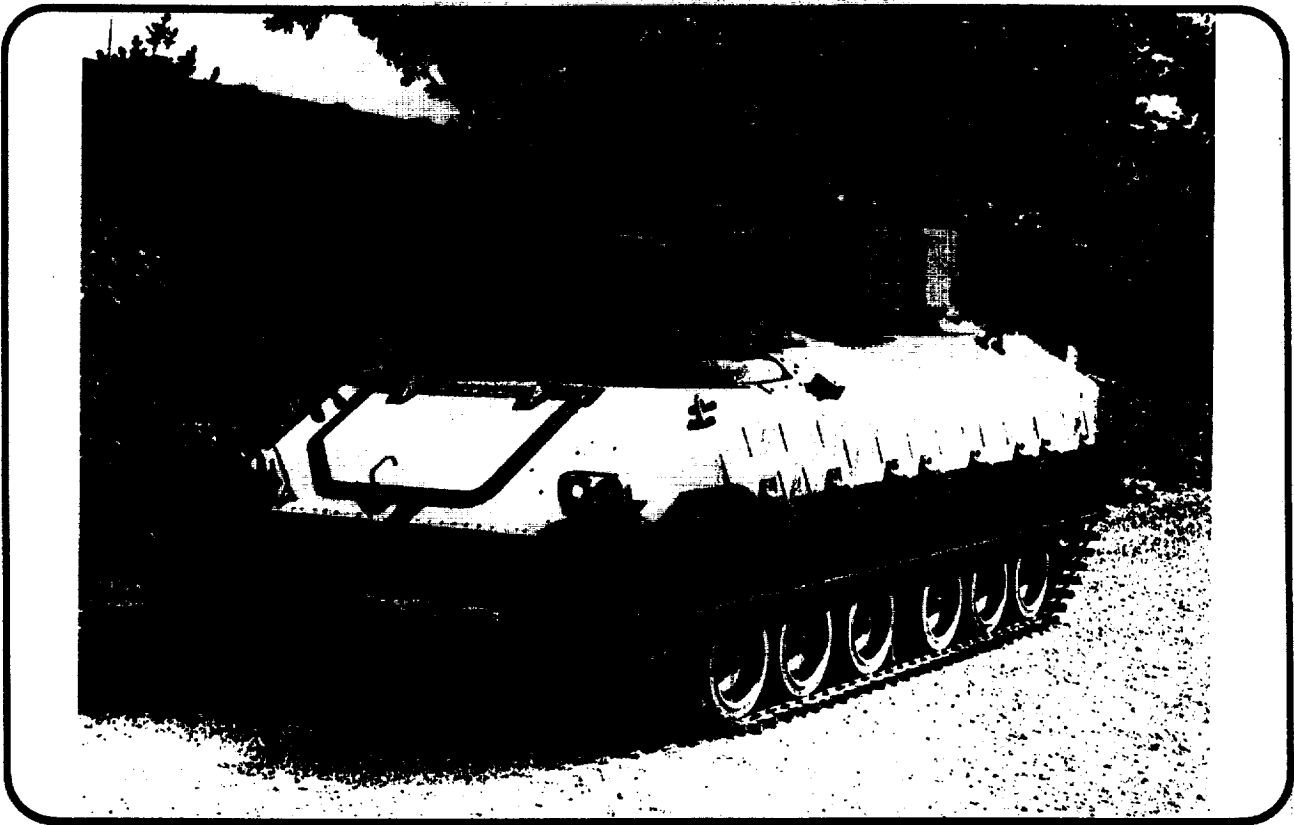

VG #14



VG #15

 <b>MATERIALS ENABLING TECHNOLOGY</b> <b>COMBAT VEHICLE COMPOSITE HULL</b> 	
<small>MATERIALS TECHNOLOGY LABORATORY</small>	
<p><b>DESCRIPTION</b></p> <ul style="list-style-type: none"> <li>• THICK-LAMINATE HI-GLASS CONTENT COMPOSITE MOLDED HULL</li> <li>• 3 STREAMLINED MOLDED PARTS REPLACE 23 WELDED METAL PLATES</li> <li>• BLAST-RESIST. COMPOSITE FLOOR</li> <li>• CERAMIC/COMPOS. &amp; EXPANDED METAL/COMPOS. SIDE ARMOR</li> <li>• PROGRAM:FABRICATE, 6000 MI. TEST, COST EST., PROVIDE SYSTEMS DEVELOPERS WITH MAT'LS SPECS.</li> </ul>	<p><b>VALUE ADDED</b></p> <ul style="list-style-type: none"> <li>• 25% WT SAVING (hull &amp; armor) EQUAL BALLISTIC PROTECTION</li> <li>• REDUCED SPALL (Survivability)</li> <li>• NO CORROSION (Maintainability)</li> <li>• SIGNATURE REDUCTION</li> <li>• REDUCED LIFE CYCLE COST</li> <li>• LOGISTICS IMPROVEMENTS</li> <li>• MOBILITY</li> <li>• TRANSPORTABILITY</li> <li>• LESS FUEL CONSUMPTION</li> </ul>
<p><b>STATUS</b></p> <ul style="list-style-type: none"> <li>• PH. 1 DONE, ON TIME, IN BUDGET</li> <li>• STRUCTURAL ANALYSIS DONE, CONCEPT SELECTED: 25% WT SAV.</li> <li>• FULL-SCALE STRUCT. &amp; BALLISTIC SPECIMENS MET PERFORM. REQUIRE.</li> <li>• PH. 2 TOOLING DESIGN UNDERWAY</li> </ul>	<p><b>FY89-94 PLANS</b></p> <ul style="list-style-type: none"> <li>• HULL FABRIC. &amp; TEST- mid '89</li> <li>• FLAMMABILITY CHARACT. - mid '89</li> <li>• MMT*AUTOMATED FABRIC. - FY91 (not funded)</li> <li>• INSTALLATION ON VEHICLE FOR 6000 MI. FIELD TEST - mid FY91</li> <li>• MATERIALS PROCESS. &amp; SPEC. DATA TO TACOM - FY91</li> </ul>

VG #16

# Composite Hull Program

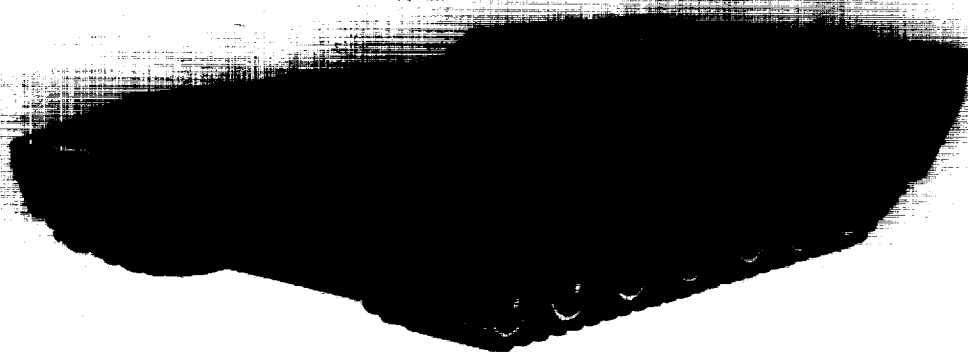

VG #17

## COMPOSITE HULL PROGRAM Hull Exploded

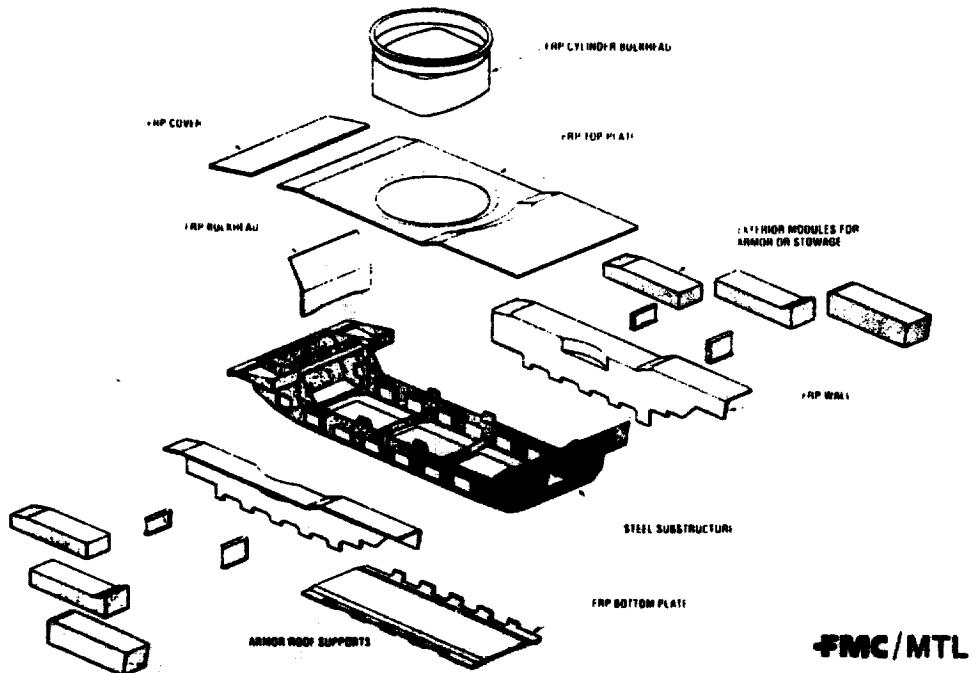

VG #18

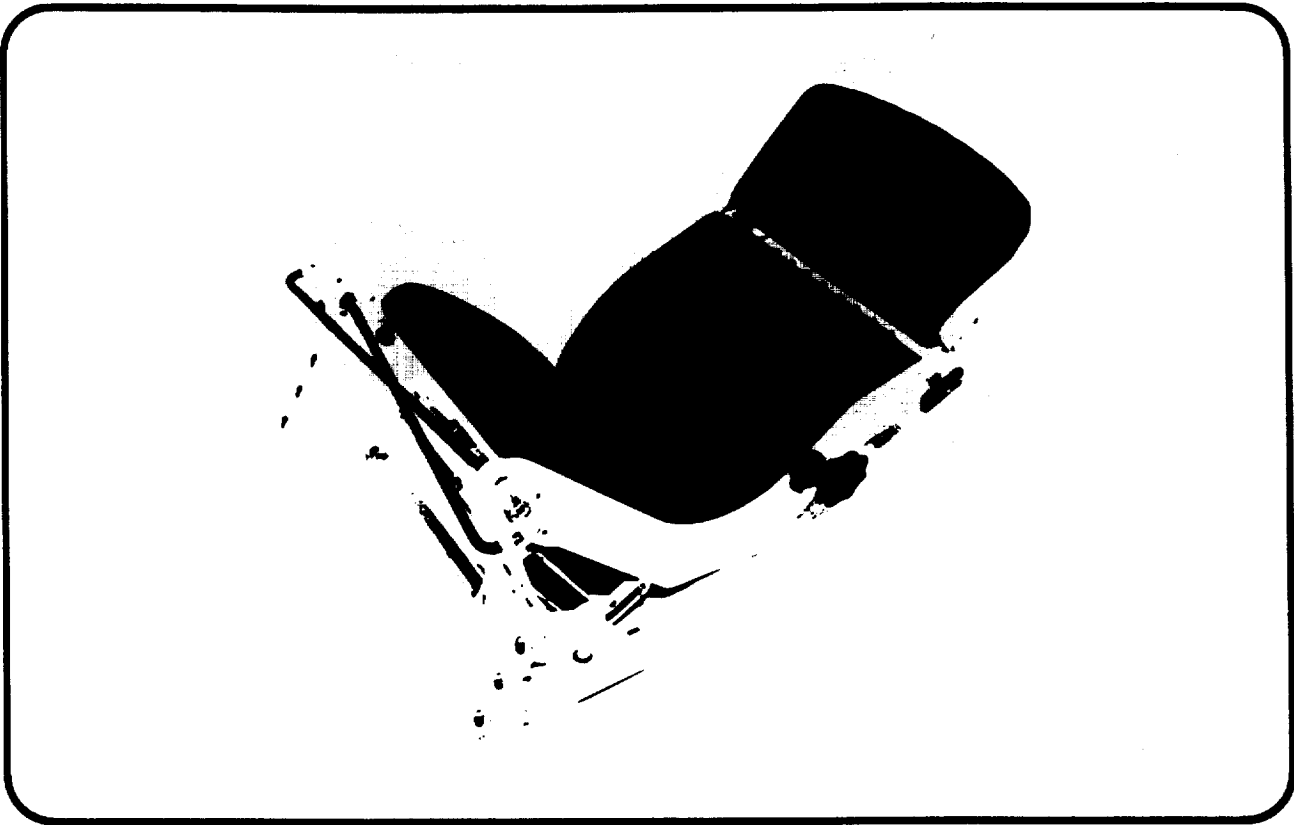

VG #19

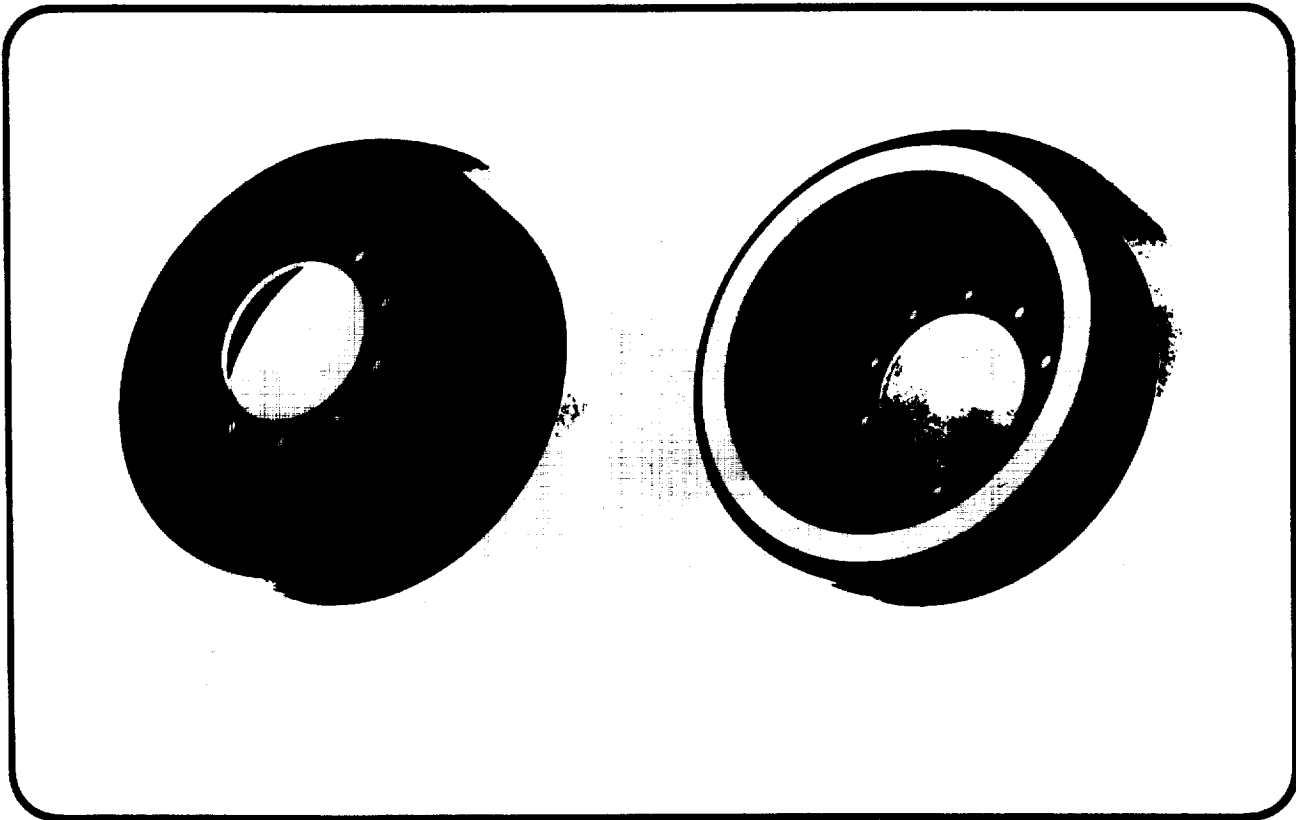

VG #20

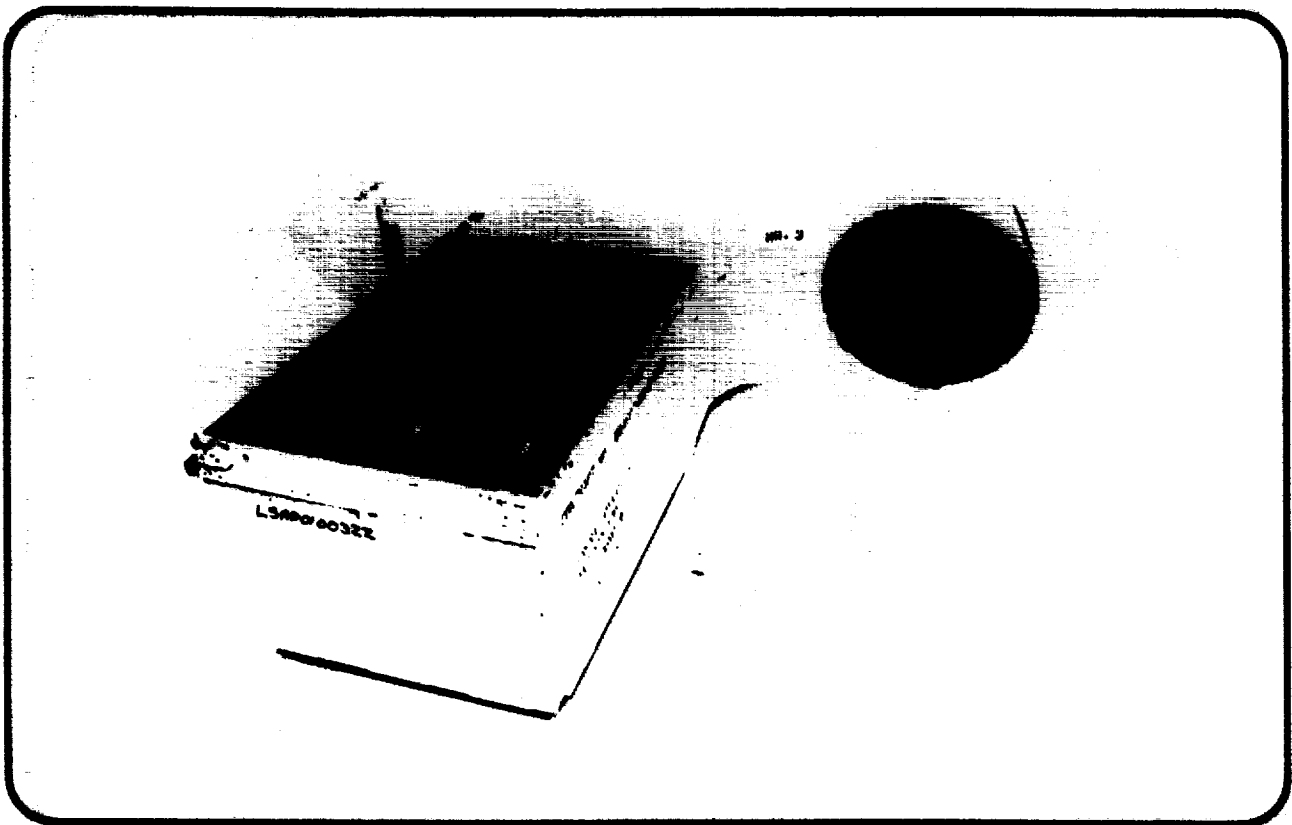

**VG #21**

**COMPOSITE FULL-UP POWER PACK CONTAINER**



**2000 POUND WEIGHT SAVINGS  
COMPARED TO METAL DESIGN**

1AC1434801

**VG #22**

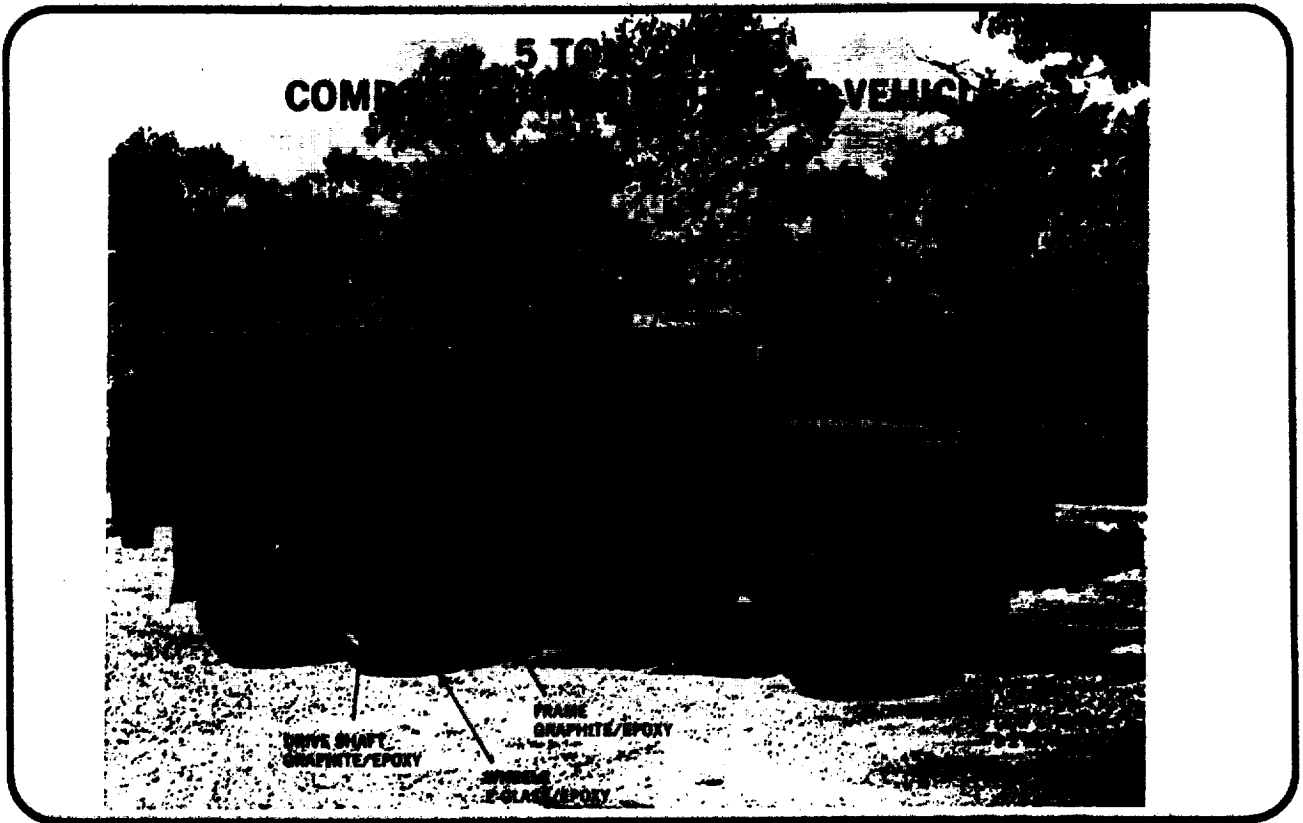

VG #23



VG #24

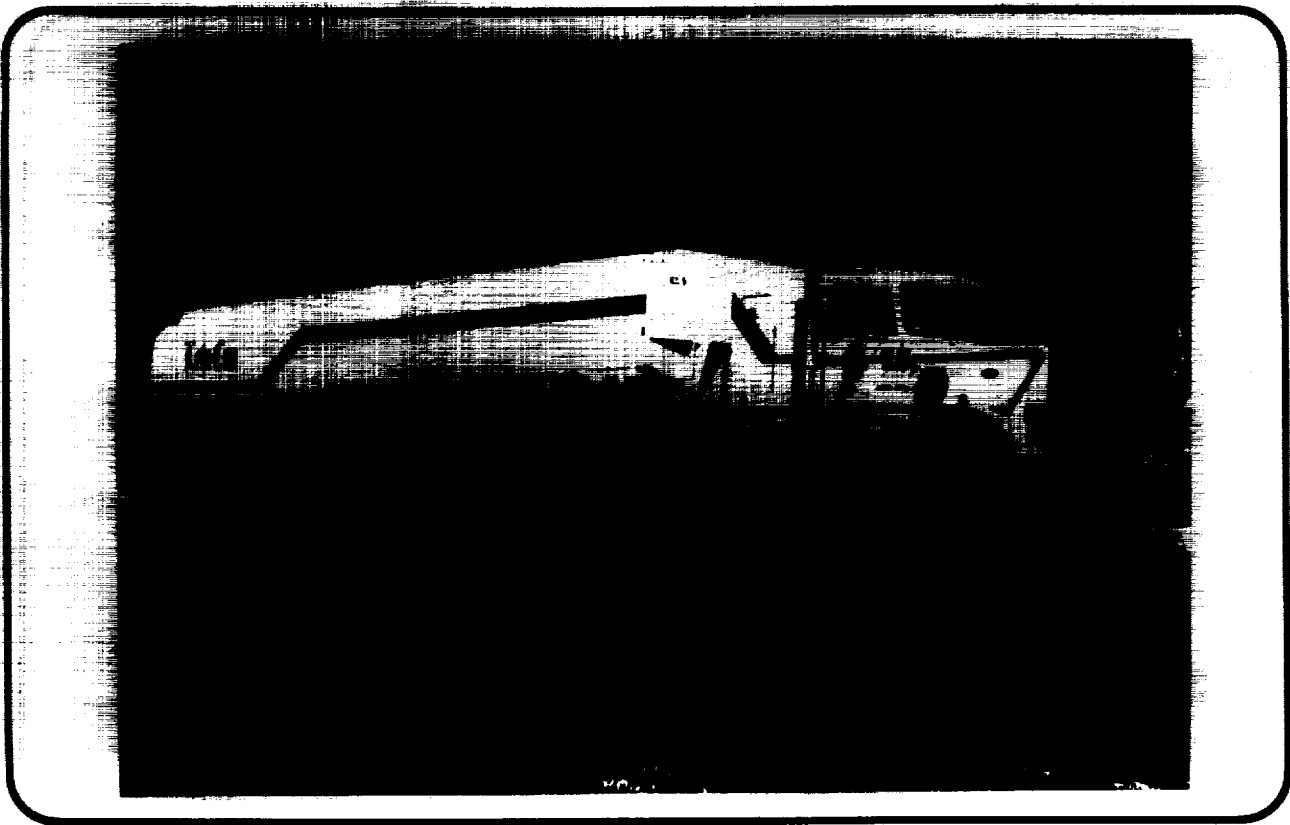

VG #25

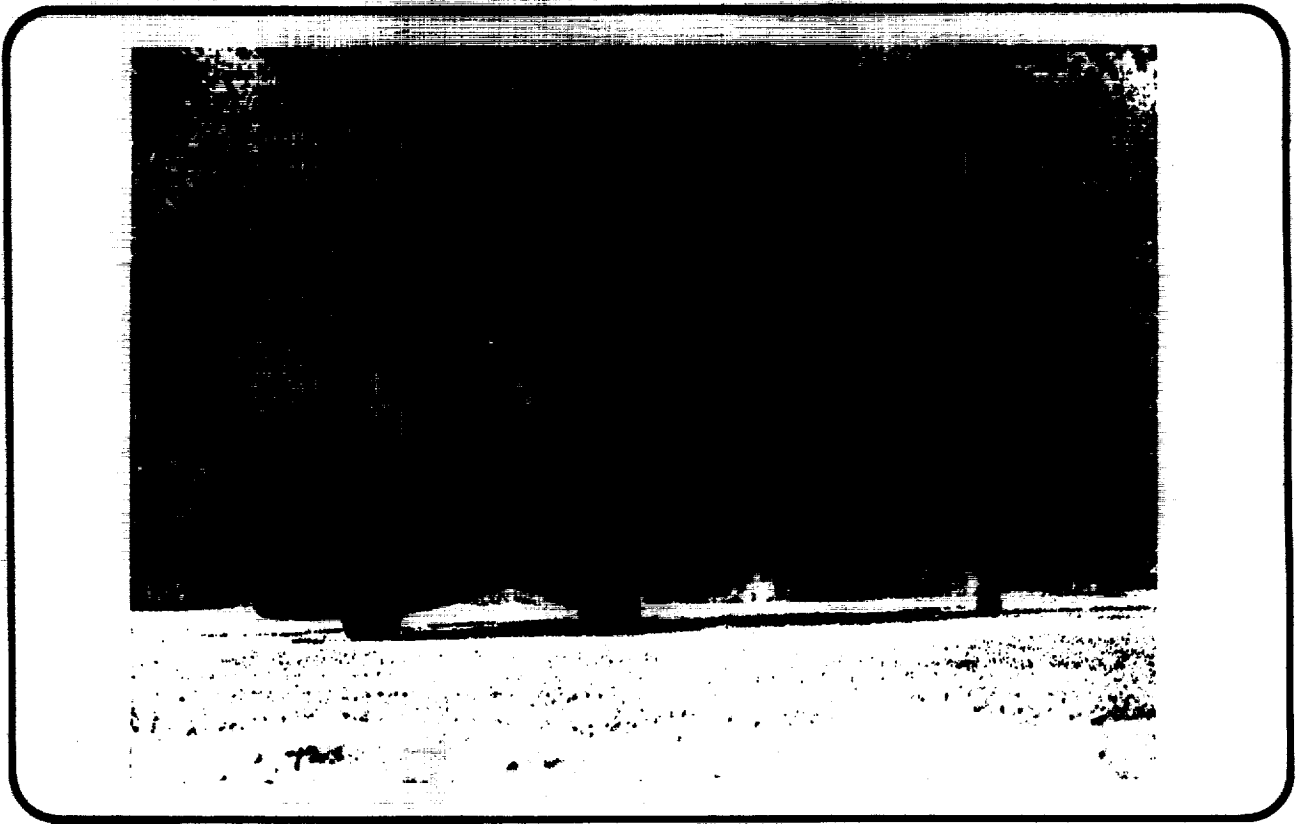

VG #26



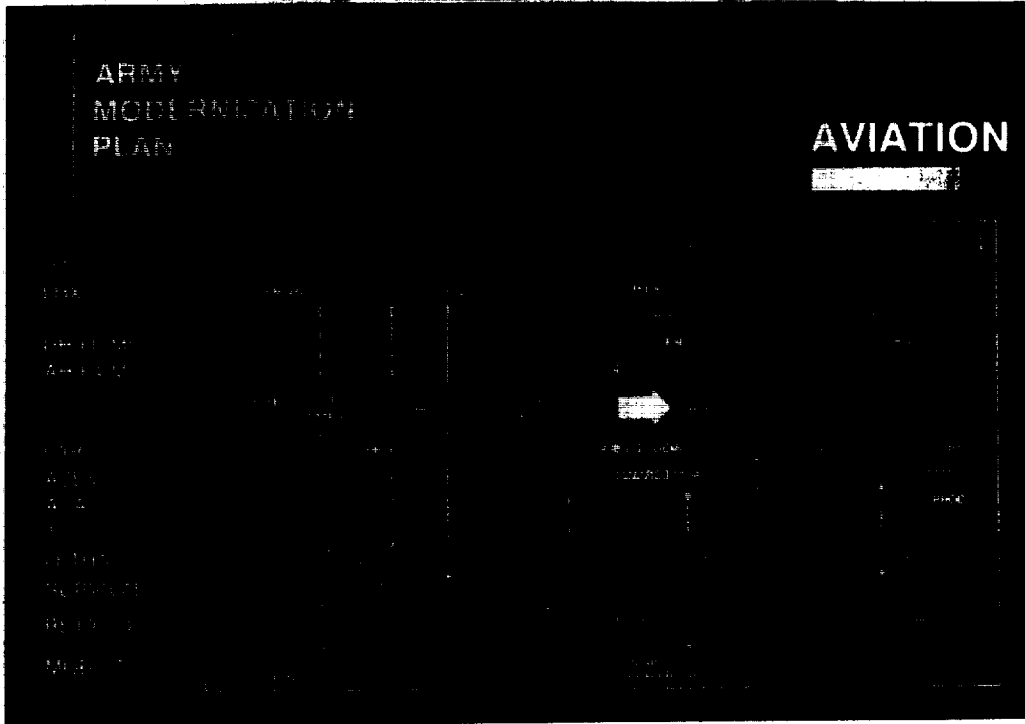

VG #27

## LH Material Utilization

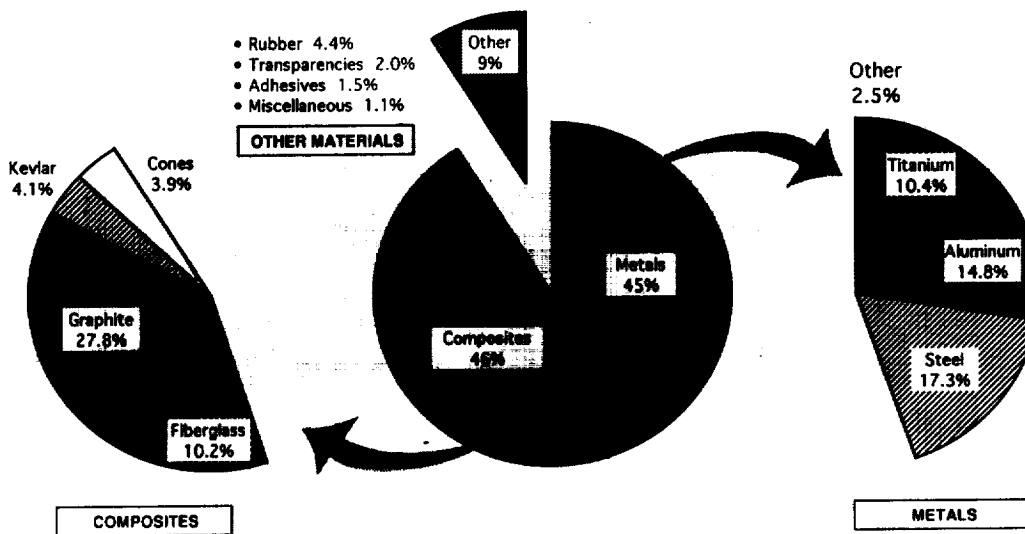

Percentage of Weight of Materials Used (Aircraft Weight)

VG #28

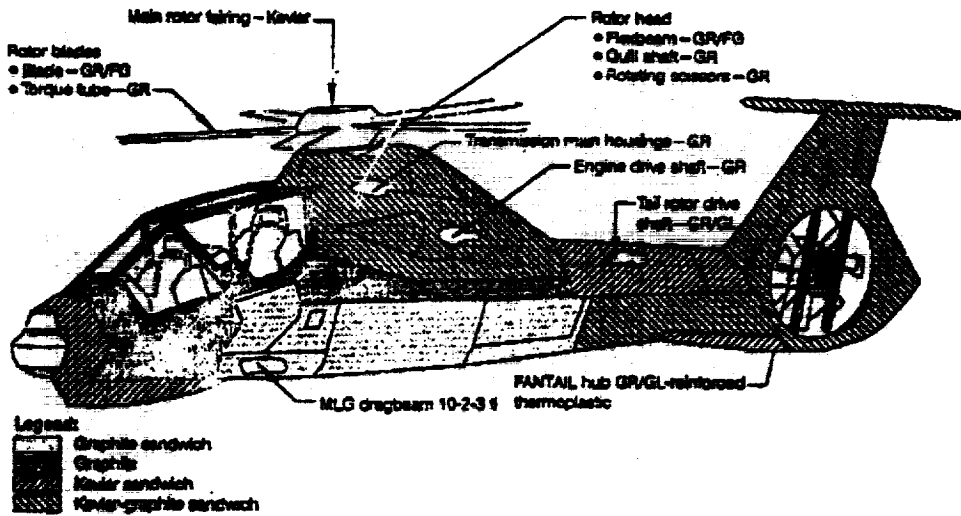

VG #29

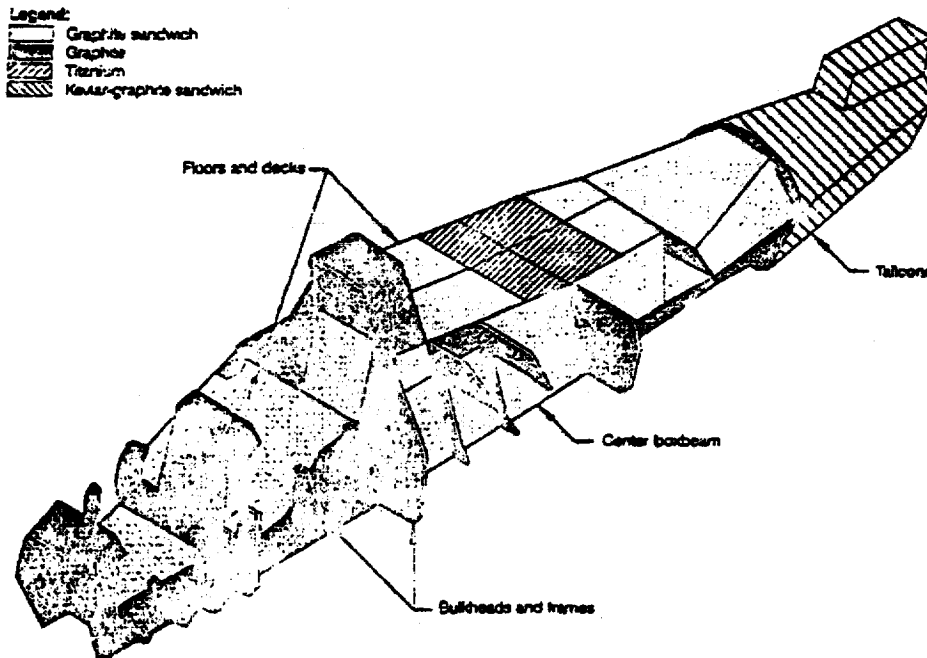

VG #30

## VERTICAL STABILIZERS TESTS

- Pre Ballistic Fatigue
- Damage (12.7mm)
- Post-Ballistic Fatigue
- Repair
- Post-Repair Fatigue

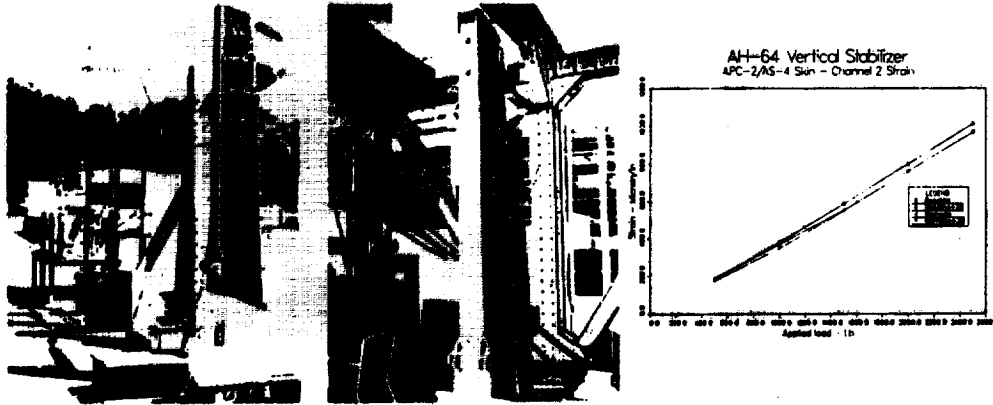

A0368 91 1147 3

VG #32

## PORTABLE FIELD REPAIR SYSTEM (CRDA)

### RESULTS:

- **TEMPERATURE DISTRIBUTION TESTS:**
  - UNIFORM TEMPERATURE PROFILE ACROSS PAD
  - REGIONAL HEATING OUTSIDE PAD REGION
- **TENSILE COUPON TESTING:**
  - SHEAR LOADS UP TO 91% OF ADHESIVE MANUFACTURER'S PREDICTED FAILURE LOAD
- **SHEAR PANEL REPAIR:**
  - REPAIRS WITH INDUCTION HEATING AND HEAT BLANKET TECHNIQUES
  - FAILURE COMPARISONS OF UNDAMAGED, DAMAGED, AND REPAIRED PANELS

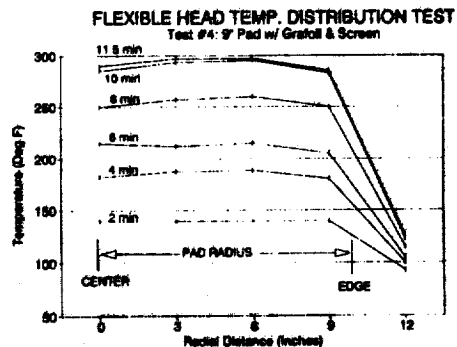

TENSILE COUPON TESTS  
977-2/AS4 ; 3M EC-3508 B/A Adhesive

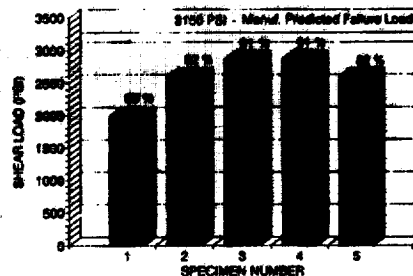

VG #33

- **Hypervelocity Structural Development** includes a family of Composite Motorcases from SPIKE to ADKEM with velocity capabilities up to 2000 m/s.

- **Kinetic Energy Penetrator Lethality Test Vehicles** for performing Full Scale Tests.

- **Composite Motorcase Development for Insensitive Munitions Tests** on SHRIKE, HELLFIRE, and AAWS-M Systems.

- **Development of Composite Missile Subsystem Prototypes** such as Wings, Fins, Storage Bottles, Blast Shields, and Nozzles.

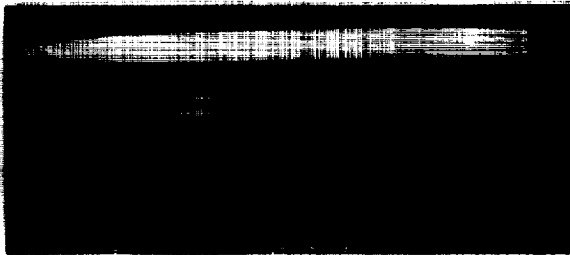
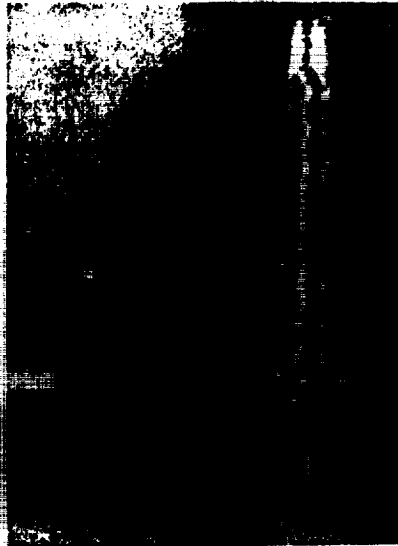

**VG #34**



**VG #35**



# COMPOSITE USE IN MUNITIONS

## ○ Casings for Improved Conventional Munitions

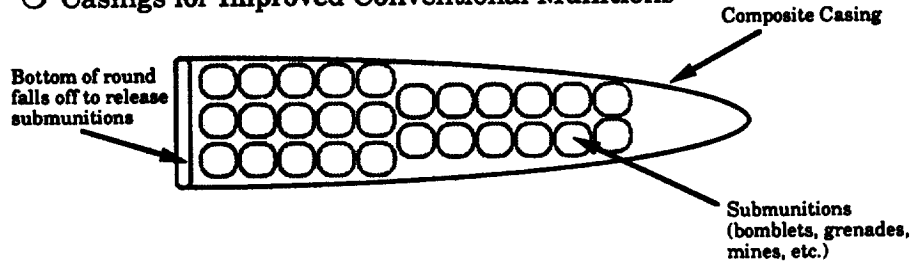

## ○ SABOTS

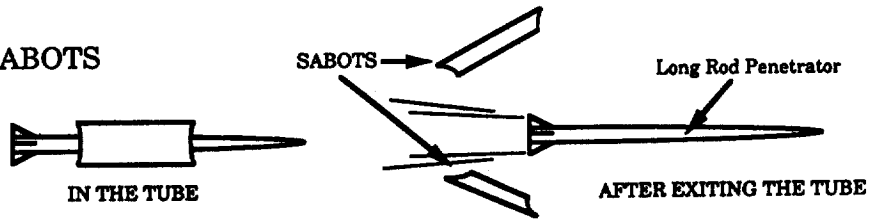

VG #36

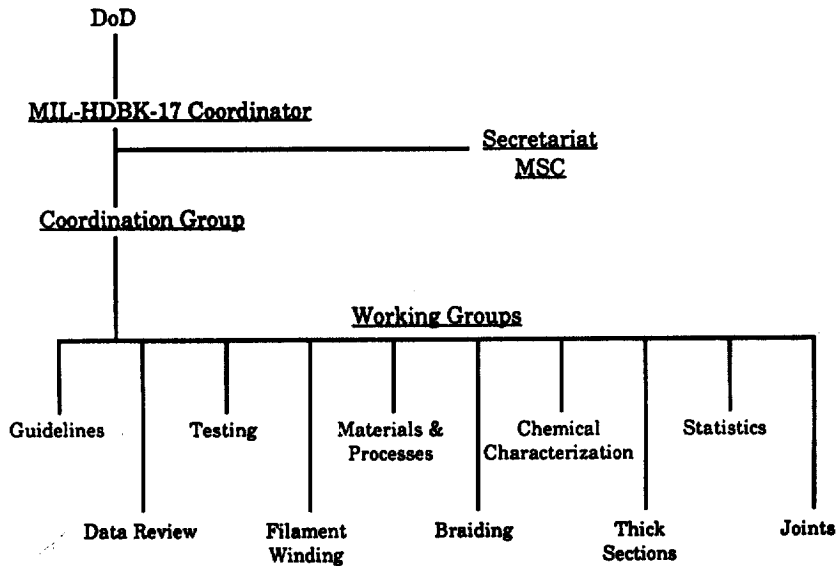

\* September 1991 -- Now

VG #37



## MIL-HDBK-17 POLYMER MATRIX COMPOSITES

- MIL-HDBK-17, Guidelines for Generating Material Property Data
  - Release:
  - 90% complete
- MIL-HDBK-17-2B, Material Property Data
  - Release:
  - 13 materials plus all current MIL-HDBK-17A data
- MIL-HDBK-17-3C, Utilization of Data
  - Release:
  - 60% complete

VG #38



## VOLUME 2

	Received	Approved
Carbon/Epoxy	39	10
Carbon/Bismaleimide	4	4
Aramid/Epoxy	2	
Glass/Epoxy	1	
Carbon/PEEK	2	1
Carbon/Polyimide	1	1
Quartz/Bismaleimide	1	1
	50	17

VG #39

GLASS POLYESTER  
TEMPERATURE PROFILE



VG #40

GLASS POLYESTER  
DEGREE OF CURE PROFILE

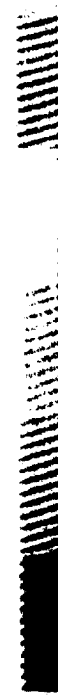

VG #41

## URI CENTER ON MANUFACTURING SCIENCE, RELIABILITY AND MAINTAINABILITY

### RESEARCH ACCOMPLISHMENTS

- STOCHASTIC MODEL FOR PREDICTING CURE IN THICK SECTION COMPOSITES
- PERFORMANCE MAPS FOR DESIGN/MANUFACTURE OF 3-D TEXTILE COMPOSITES
- CONCURRENT ENGINEERING DESIGN METHODOLOGY
- COMPREHENSIVE MODEL FOR THERMO-PLASTIC FILAMENT WINDING

### FY 1986 - FY 1991 FUNDING \$(K)

	FY86 - FY90 ACTUAL	FY91 PROJECTED
RESEARCH	\$2,316	\$706
FELLOWSHIPS	\$ 819	\$ 0
EQUIPMENT	\$1,019	\$ 0

### TECHNOLOGY TRANSFER

- IMPROVED CURE CYCLE FOR COMPOSITES IN ADVANCED INFANTRY FIGHTING VEHICLE (FMC, MTL)
- CONCURRENT ENGINEERING APPROACH FOR COMPOSITES IN MISSILE COMPONENTS (MCOM)
- DESIGN OF COMPOSITE AIR CREW MASK COMPONENTS (CRDEC)
- COMPOSITE LIGHTWEIGHT TRAILER DESIGN (TACOM, SANDAIRE CORP.)

### EDUCATION

- 15 GRADUATE FELLOWSHIPS AWARDED
- 6 PHDS, 1 MS EARNED
- OVER 50 RESEARCH PAPERS PUBLISHED
- WORKSHOPS, SYMPOSIUMS, COURSES FOR DOD PERSONNEL
- RESIDENCY PROGRAM FOR ARMY SCIENTISTS
- 3 ARMY OFFICERS PURSUING ADVANCED DEGREES

VG #42

## Processing-Induced Stress and Deformation in Thick-Section Thermosetting Composites

T. A. Bogetti (Ph.D. ME) Advisor: J. W. Gillespie, Jr.

### RESEARCH GOALS

- Develop a model to study the development of processing induced stress and deformation in thick-section thermosets by modeling the curing process accounting for:
  - Thermo-chemical cure interactions
  - Thermal and cure induced dilation
  - Non-isothermal kinetic viscoelasticity
  - Arbitrary cross-sectional geometries
- Verify the model's cure simulation, stress and deformation predictions with experiments.
- Optimize cure cycles for thick-section thermosets by relating processing history to the state of the final component.

### VISCOELASTIC STRESS/STRAIN CONSTITUTIVE MODEL

Nonisothermal, anisotropic stress-strain relation:

$$\sigma = \int_0^t \xi(t-\tau) \frac{d\epsilon(\tau)}{d\tau} d\tau$$

Reduced time accounts for  $\xi$  history dependence

$$\xi(t) = \int_0^t \phi(\tau) d\tau$$

Where  $\phi(\tau)$  is temperature and degree of cure dependent.

### CONTRASTING DEGREE OF CURE PROFILES (% Cured)

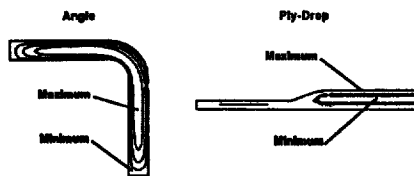

Graphite/Epoxy Cures Inside-Out

Glass/Polyester Cures Outside-In

### INCREMENTAL FINITE ELEMENT APPROACH

Reduce the viscoelastic solution to the superposition of elastic partial stress components:

$$\sigma^{(n)} = \int_0^t H_n^i(\xi) \frac{d\epsilon^{(n)}}{d\tau} d\tau$$

Where the history dependence is recovered by

$$H_n^i = \frac{1}{\Gamma_n - \Gamma_{n-1}} \int_{\Gamma_{n-1}}^{\Gamma_n} \xi(\tau) d\tau$$

VG #43



# Microstructure-Property-Failure Relationships for 3-D Woven Composites

B. LaMattina (M. ME) Advisor: A. Parvizi-Majidi

## OBJECTIVES

- Provide an understanding of the microstructure-property-failure relationships for 3-D woven composites.
- Develop and study RTM processing for 3-D fabric composites.
- Model the impact behavior and damage of fabric composites to provide a tool for the optimization of weave geometry.

## 3-D ANGLE INTERLOCK WEAVE

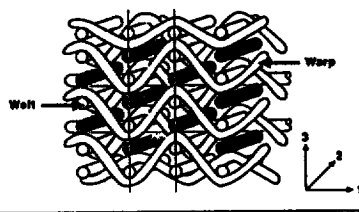

## RTM MOLD



## PHOTOMICROGRAPHS

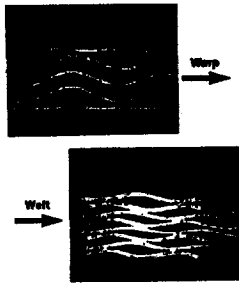

## WEAVING LOOM

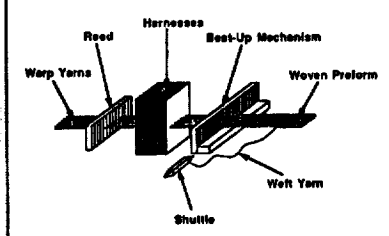

## MODULI VS. WARP ANGLE

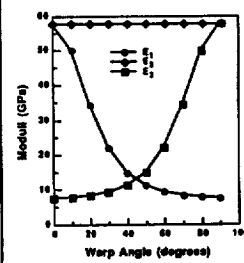

VG #44

# Design and Automated Fabrication of 3-D Braided Preforms for Structural Composites

T. D. Kostar (M. ME) Advisor: T-W. Chou

## BACKGROUND

Three-dimensional braiding offers unique benefits to the science of composite preforming. These include:

- A built-in through-the-thickness reinforcement to prevent delamination
- The ability to fabricate both thick and complex shapes
- Net-shape preforming capability

The much needed research in the following areas is under way.

- Automated Preform Fabrication
- Preform Consolidation
- Composite Property Predictions

This present research focuses on the automated, intelligent fabrication of three-dimensional braided preforms for composites.

## GOALS

- Fully automate the 3-D braiding process.
- Develop process model to relate operating conditions to preform architecture.
- Upgrade control software to allow for tailored design of preform shape and microstructure.

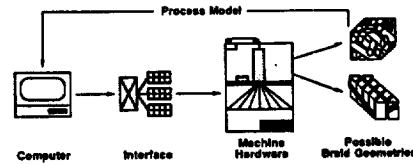

## PROCESS MODELING

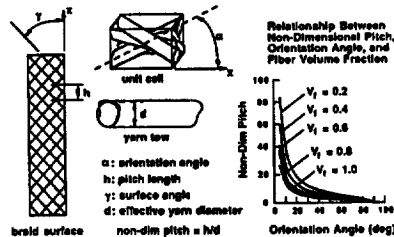

VG #45

# Preform Design and Manufacturing for Liquid Molding

D. A. Steenkamer (Ph.D. ME) Advisor: D. J. Wilkins

## OBJECTIVES

- Define a preform design environment based on the fiber architectures which are attainable with current textile processes.
- Develop analysis tools and processing heuristics to support the preform design environment.
- Devise a technique to efficiently join separate preform sections.

## DEVELOPMENT OF PREFORM FIBER ARCHITECTURE FOR LIQUID MOLDING

### Fiber Orientation Processes

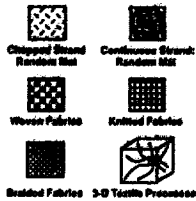

### Preform Shaping Processes

- Braiding
- Cut-and-Place
- Directed Fiber Preforming
- Knitting
- Stamping of Thermosettable Materials
- Weaving
- 3-D Textile Processes

## LIQUID MOLDING PROCESS

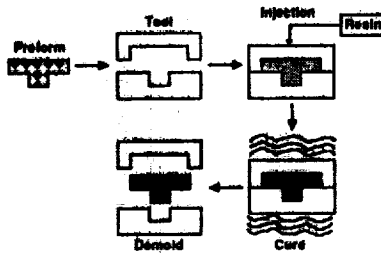

## PREFORM DESIGN AND ANALYSIS

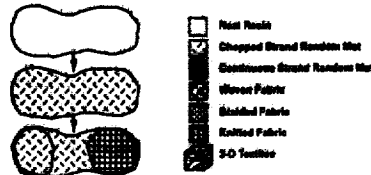

VG #46

# DYNAMIC RESPONSE PROGRAM

*The Effects of Curvature and Thickness on Impact Damage in Composite Structures*  
 Prof. Fu-Kuo Chang, Stanford University

**GOAL:** Develop an analytical model to predict low velocity impact damage and to study failure mechanisms (cracking, delamination) in composite structures. Conduct experimental validation of the theory.

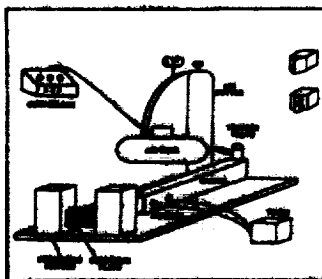

Impact test facility

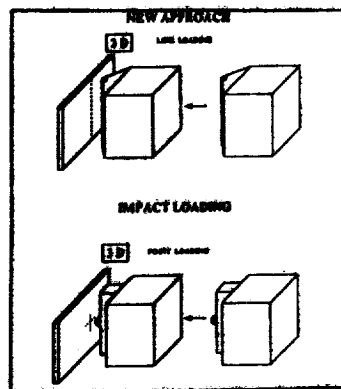

Line and point impactors

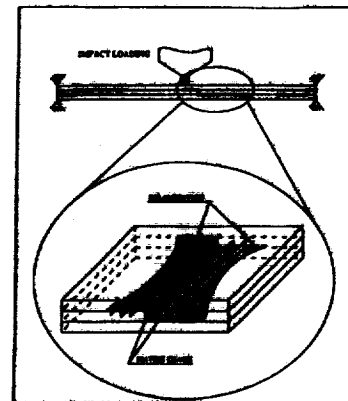

Typical impact damage pattern in symmetric [0, 90] composites

VG #47

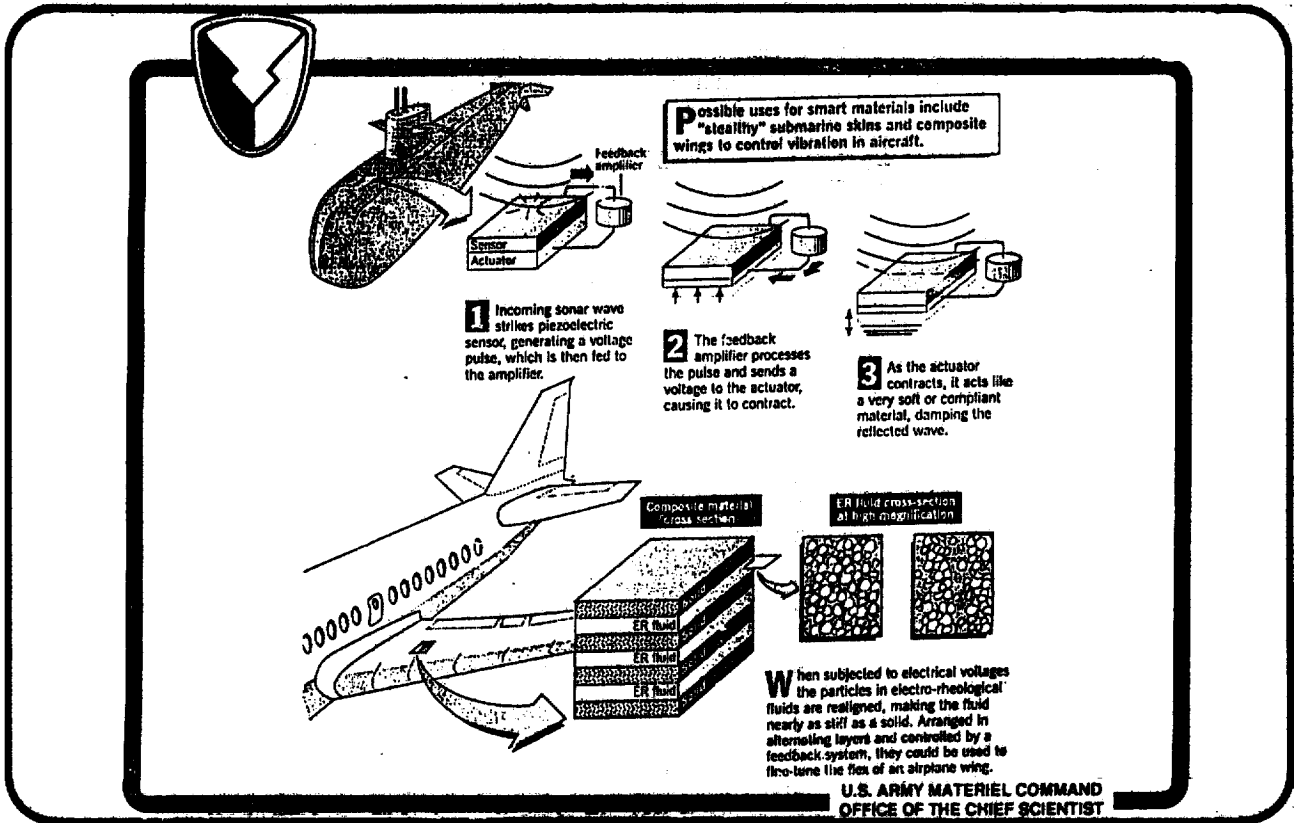

VG #48

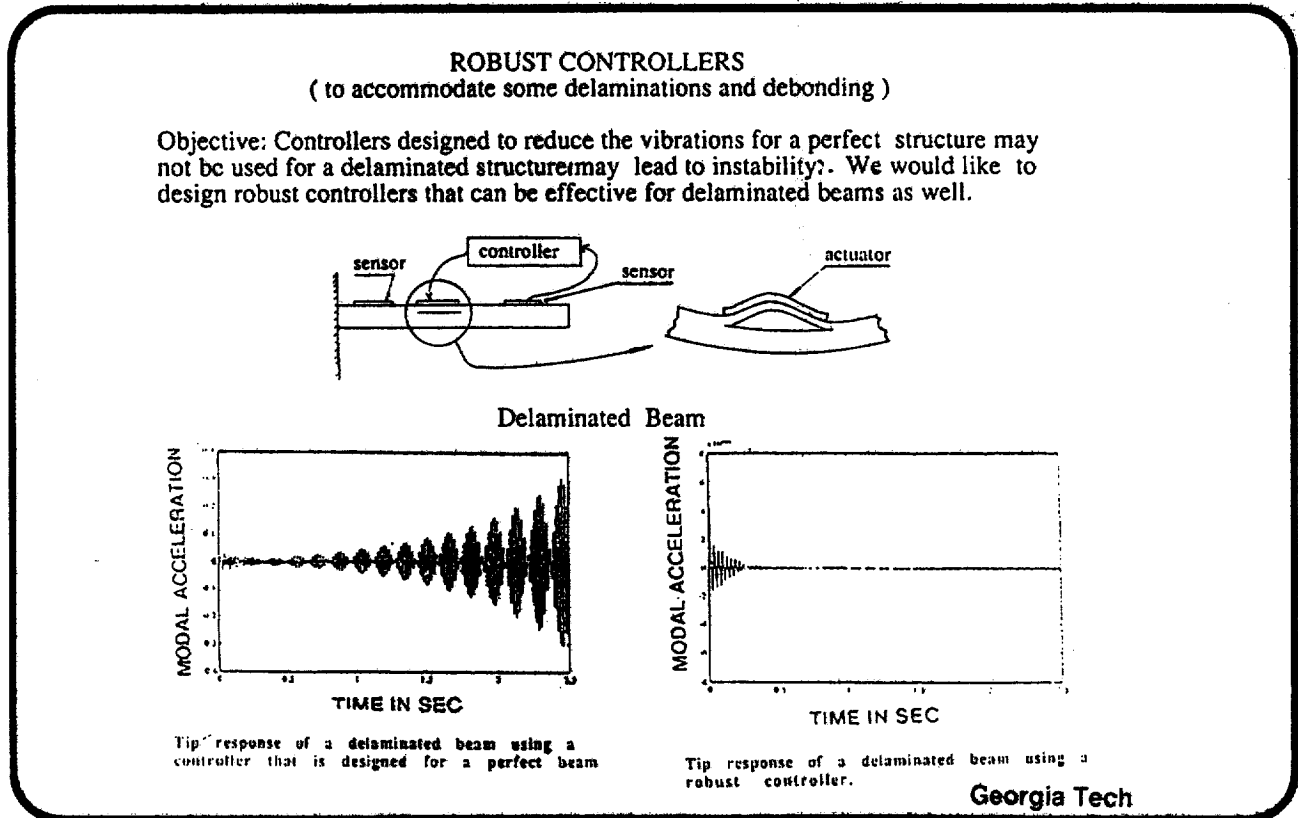

VG #49

## BLADE VORTEX INTERACTION

Objective: We would like to discuss the feasibility of controlling the magnitude of the pressure pulse due to the interaction of the rotor blade with shed vortices of preceding blades, by using actuation that changes the shape of the airfoil.

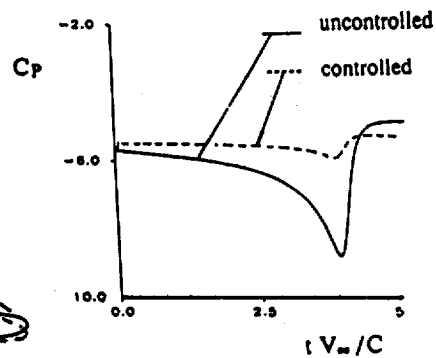
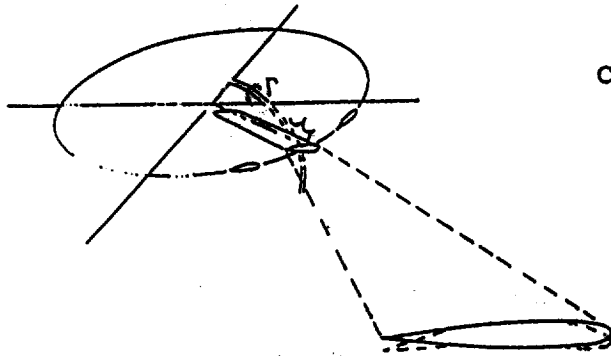

Active control by the use of shape memory alloys or piezo electric actuators (to change the shape of the airfoil) and optimum control techniques.

Georgia Tech

VG #50

U. S. ARMY MATERIEL COMMAND



## CONCLUDING REMARKS

- Diverse Mission
- Stable Funding For Tech Base
- Need For Advanced Materials
- Need For Composite Materials
- Effective Technical Planning

VG #51