

**STRUCTURAL TESTING OF THE
TECHNOLOGY INTEGRATION BOX BEAM**

C. F. GRIFFIN

**LOCKHEED AERONAUTICAL SYSTEMS COMPANY
MARIETTA, GEORGIA**

SUMMARY

51345
P-13
2 5 11
1485

A full-scale section of a transport aircraft wing box was designed, analyzed, fabricated and tested. The wing box section, which was called the technology integration box beam, contained blade stiffened covers and T-stiffened channel spars constructed using graphite/epoxy materials. Covers, spars and the aluminum ribs were assembled using mechanical fasteners.

The box beam was statically tested for several loading conditions to verify the stiffness and strength characteristics of the composite wing design. Failure of the box beam occurred at 125% of design limit load during the combined upbending and torsion ultimate design load test. It appears that the failure initiated at a stiffener runout location in the upper cover which resulted in rupture of the upper cover and portions of both spars.

INTRODUCTION

Current applications of composite materials to transport aircraft structure, most of which are stiffness critical secondary structural components, have demonstrated weight saving from 20 to 30 percent. The greatest impact on aircraft performance and cost will be made when these materials are used for fabrication of primary wing and fuselage structures that are 30 to 40 percent lighter than their metal counterparts and have a reduced acquisition cost. Achievement of this goal requires the integration of innovative design concepts, improved composite materials, and low cost manufacturing methods.

In 1984, the Lockheed Aeronautical Systems Company began a program to develop engineering and manufacturing technology for advanced composite wing structures on large transport aircraft. The program was sponsored by the National Aeronautics and Space Administration (NASA) under contracts NAS1-17699 and NAS1-18888 and Lockheed Aeronautical Systems Company independent research and development funds.

The selected baseline component is the center wing structural box of an advanced version of the C-130 aircraft. A preliminary design of a composite wing box was completed as were many design development tests. A full-scale section of the wing box was designed in detail, analyzed, fabricated and tested. This paper will summarize the major technical achievements of the box beam test program.

BOX BEAM DESIGN AND ANALYSIS

Geometry

The technology integration box beam, shown in Figure 1, represents a highly loaded section of the C-130 center wing box. The test section of the box is 150 inches long, 50 inches wide, and 28 inches deep, and contains a large access hole in the upper cover, wing box to fuselage mainframe joints, and center wing to outer wing joints.

Design Loads and Criteria

Design loads for the box beam were based on baseline aircraft requirements. Maximum ultimate loads are 26,000 lb/inch compression in the upper covers and 24,000 lb/inch tension in the lower covers. Ultimate spar web shear flow is 4,500 lb/inch. These loads were combined with the appropriate pressure loads due to beam bending curvature and fuel. The stiffness requirements for the wing were established to meet the commercial flutter requirements specified in FAR Part 25. Stated briefly, at any

wing station the composite wing bending stiffness and torsional stiffness could not be less than 50 percent of the baseline wing, and the ratio of the bending to torsional stiffness must be greater than one but not more than four.

Structural requirements for damage tolerance considered civil as well as military criteria. Thus, the criteria used for this program requires the structure to have ultimate strength capability with the presence of barely visible impact damage anywhere within the structure. Barely visible impact damage is defined as either the kinetic energy required to cause a 0.1 inch deep dent or a kinetic energy of 100 ft-lb with a 1.0 inch diameter hemispherical impactor, whichever is least.

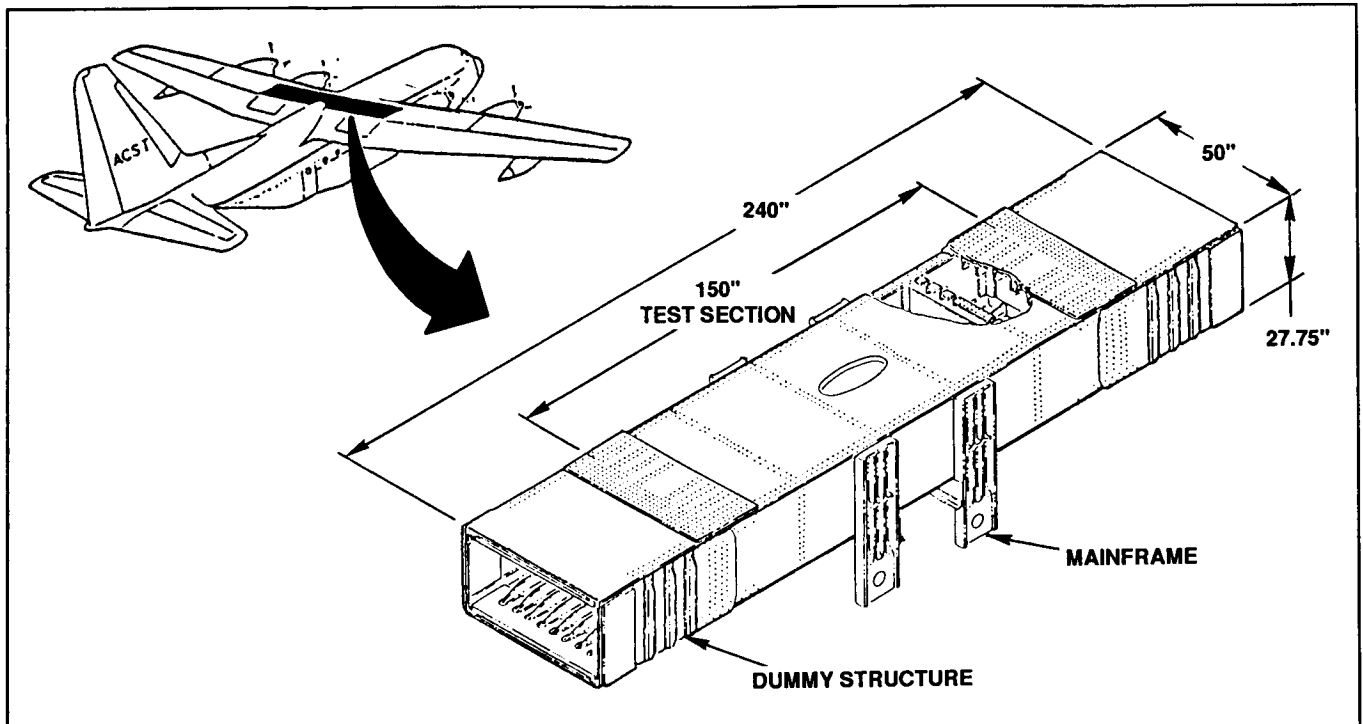

Figure 1. Technology Integration Box Beam
Cover Design

The lower cover design, shown in Figure 2, consists of back-to-back channels laid up on a skin laminate to form a blade stiffened panel. Note that the flanges of the channels contain additional 0 degree plies compared to the web, resulting in a blade containing 67 percent 0 degree plies, 29 percent plus/minus 45 degree plies, and 4 percent 90 degree plies. The blades, which are spaced at 5 inches, are tapered in height to account for the increased axial loading from the outboard joint to the wing centerline. A constant thickness laminate containing 27 percent 0 degree plies, 64 percent plus/minus 45 degree plies, and 9 percent 90 degree plies makes up the skin.

The configuration of the upper cover, shown in Figure 3, is similar to the lower cover with the exception that the blades are slightly taller. Also, the central bay of the upper cover is reinforced by a hat stiffener which is terminated at each rib location. An 8 inch wide strip of the cover laminate below the hat stiffener has a lay-up of 44 percent 0 degree plies, 46 percent plus/minus 45 degree plies and 9 percent 90 degree plies. The remainder of the upper skin is the same laminate as was used for the lower skin. The covers were constructed using three types of AS4/974 fabric; unidirectional, bi-directional and plus/minus 45 degree bias.

Spar Design

A T-stiffened channel configuration, shown in Figure 4, was selected for the front and rear spars. Spar webs and caps are of constant thickness with the exception of the doublers located at the mainframe

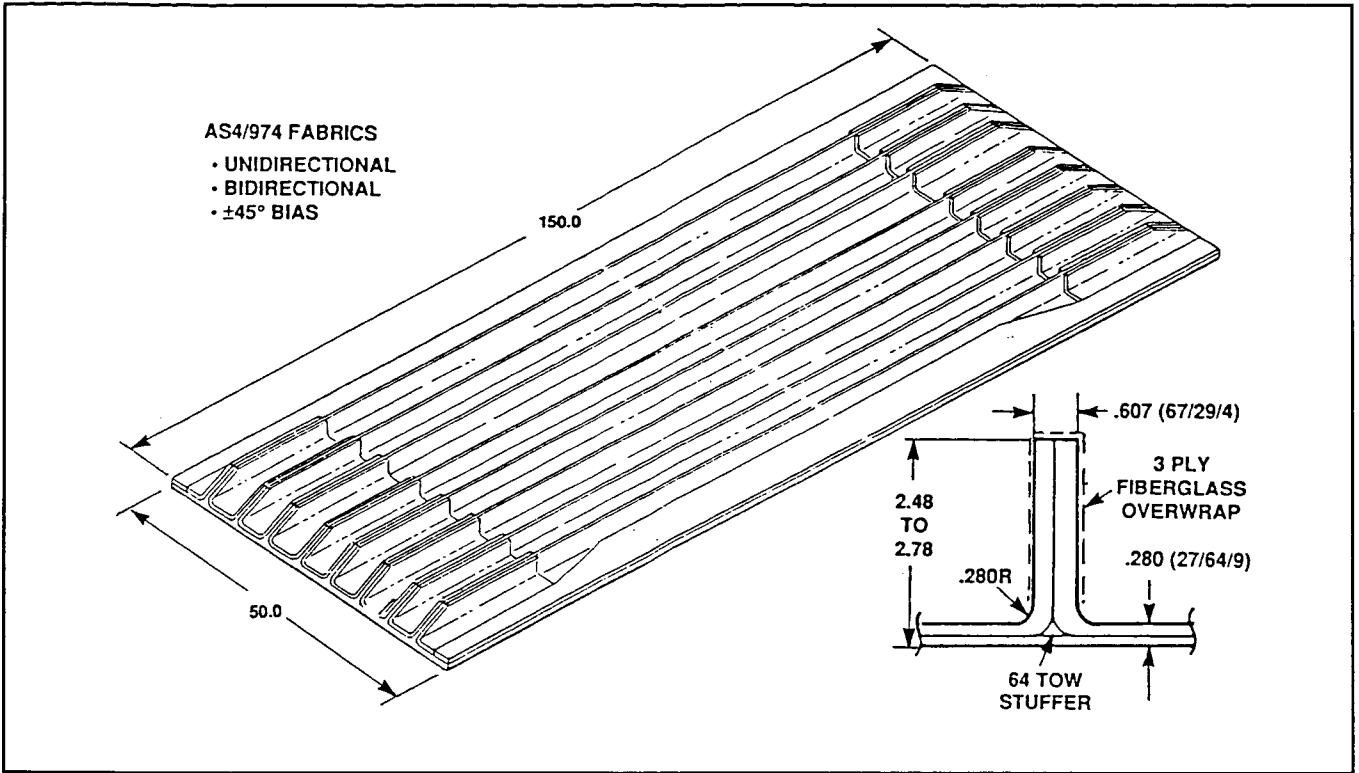

Figure 2. Lower Cover Box Beam Design

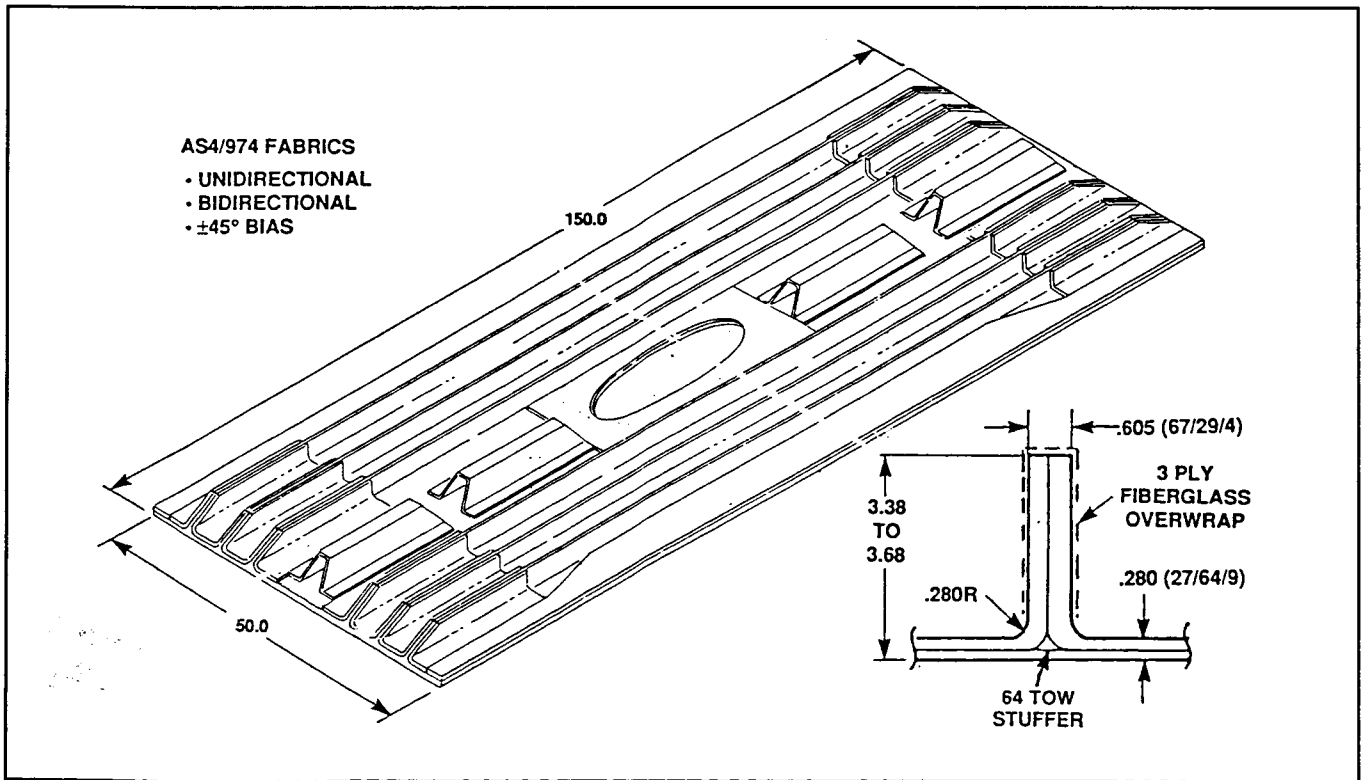

Figure 3. Upper Cover Box Beam Design

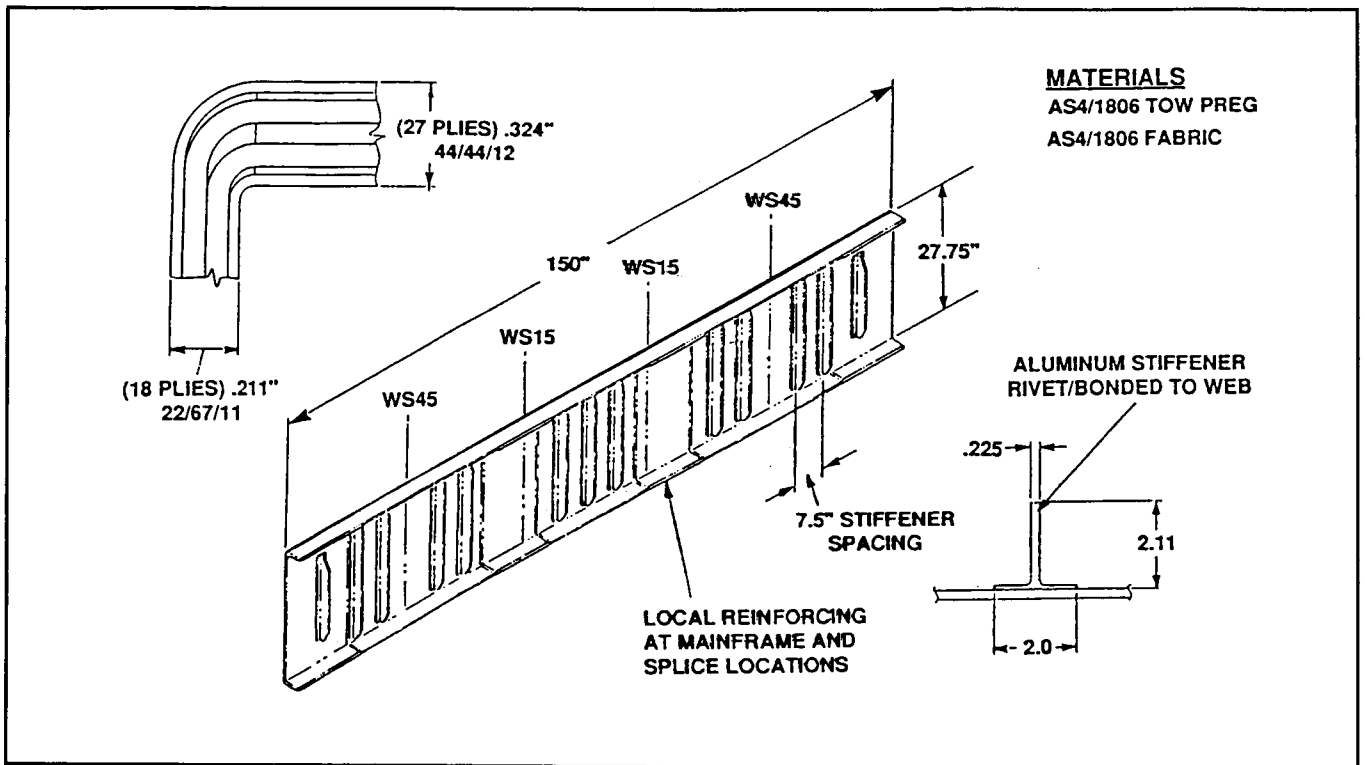

Figure 4. Spar Assembly

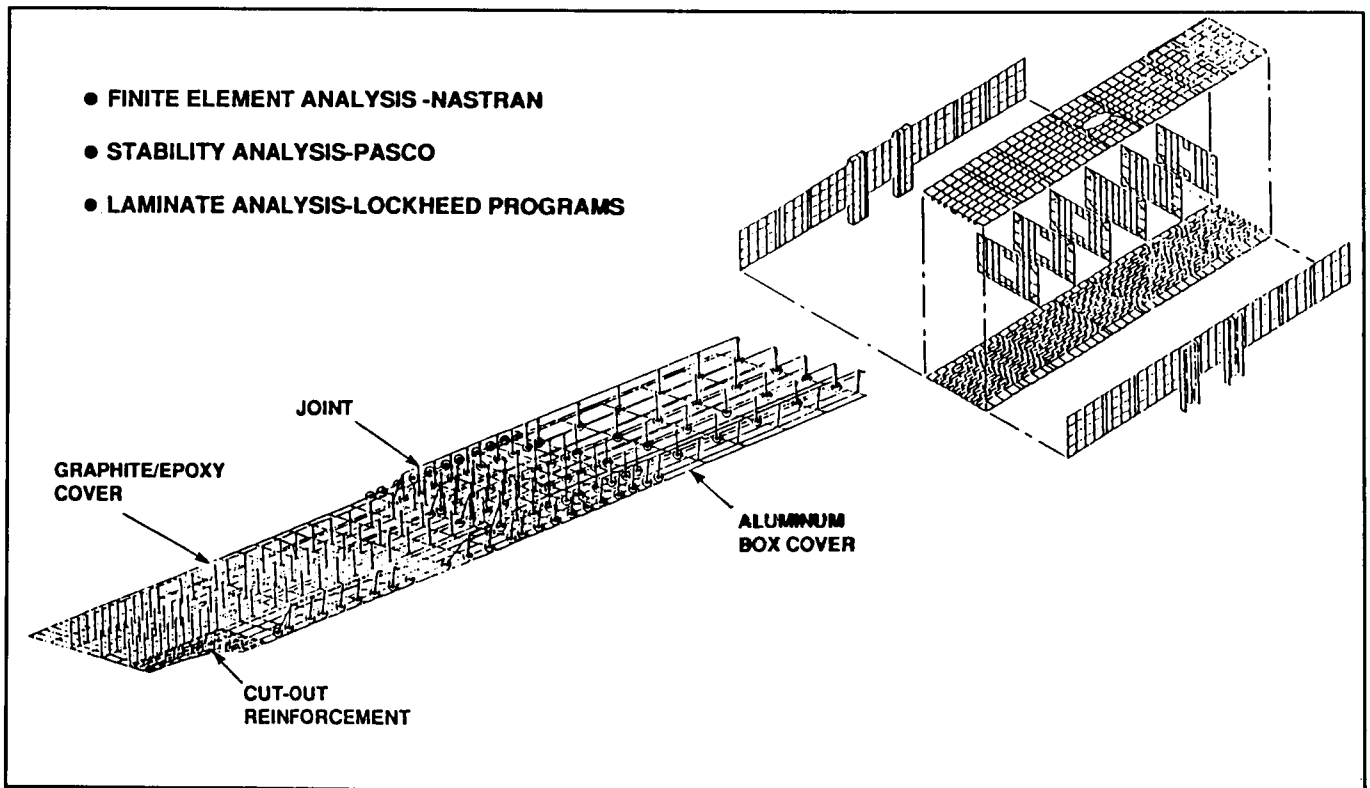

Figure 5. Structural Analysis Methods

attachment and spar splice locations. The spars were filament wound using AS4/1806 towpreg with unidirectional, bidirectional, and bias fabrics used for the spar cap inserts, and doublers. The stiffeners were made of aluminum and were bolted and bonded to the spar webs.

Ribs and Box Assembly

For the box beam, a J-stiffened skin configuration constructed of aluminum was used for all of the ribs. T-shaped shear ties connect the rib webs and rib caps to the covers. All ribs were mechanically fastened to the spar webs and covers. The spar caps were mechanically fastened to the covers using a double row of fasteners.

Structural Analysis

A detailed structural analysis was completed on the box beam using the methods shown in Figure 5. A three-dimensional finite element model was constructed and used to obtain internal loads for sixteen loads cases. Detailed two-dimensional models were used to analyze the cover chordwise joint, cover cut-out area, and the mainframe to spar joint. The compression stability of the covers was predicted using the PASCO computer code obtained from NASA. Several Lockheed computer programs were used to obtain local stresses and strains using the internal loads obtained from the NASTRAN models.

Figure 6 presents the typical design allowables obtained for the AS4/1806 and AS4/974 materials. These allowables were computed based on laminate tests, and in the case of the impacted laminate allowables, stiffened panel tests. Note that allowable strain is plotted as a function of the percentage of plus/minus 45 degree plies within the laminate minus the percentage of 0 degree plies. This value is called the AML for angle minus longitudinal plies. For example, a quasi-isotropic laminate has an AML value of 25. The blade stiffener on the cover has an AML of -38 and the majority of the cover skin a value of 37.

Margins of safety were computed for numerous locations on the covers and spars using applied strains and design allowable strains. Minimum margins of safety are presented in Figure 7. Both the upper cover and spar webs have a 0 margin of safety for the impact damaged condition. The lower cover and the spar caps are critical for bearing/bypass and net tension, respectively.

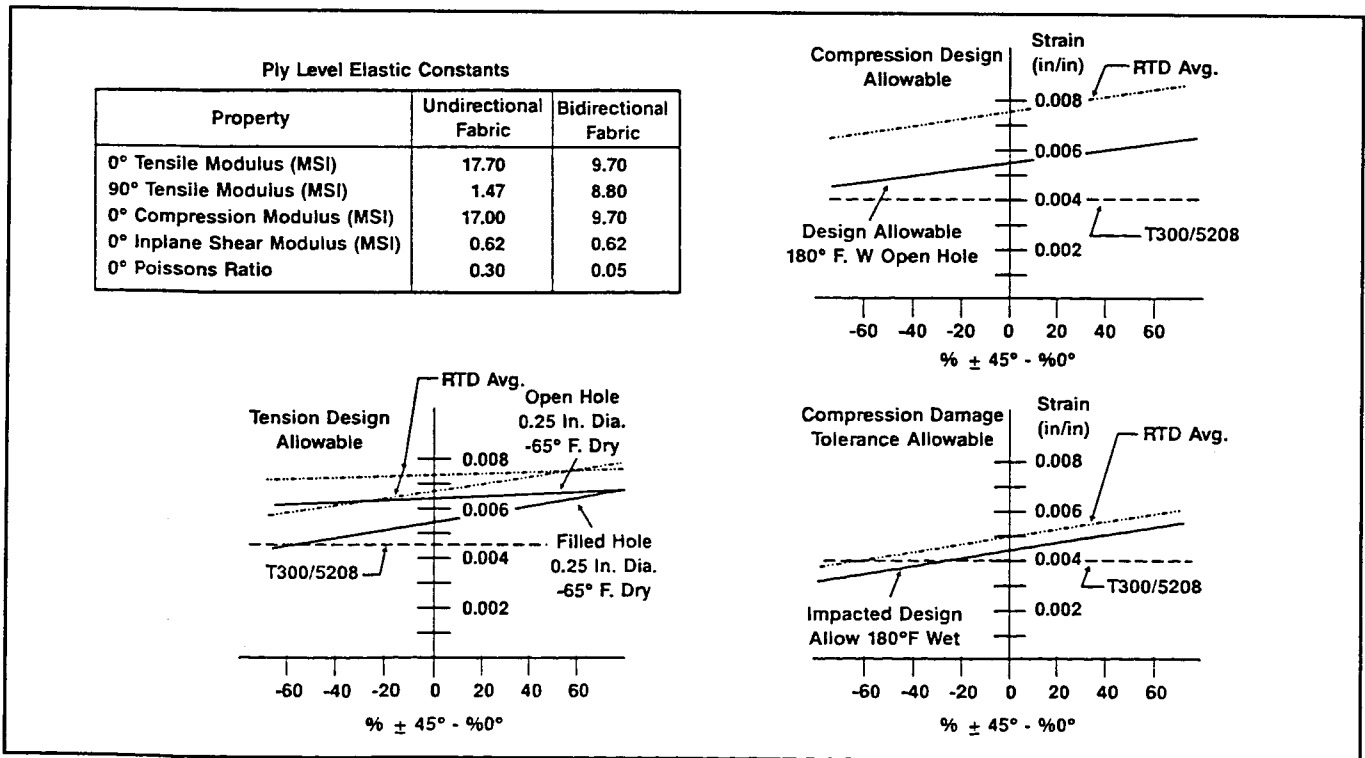

Figure 6. Design Allowables

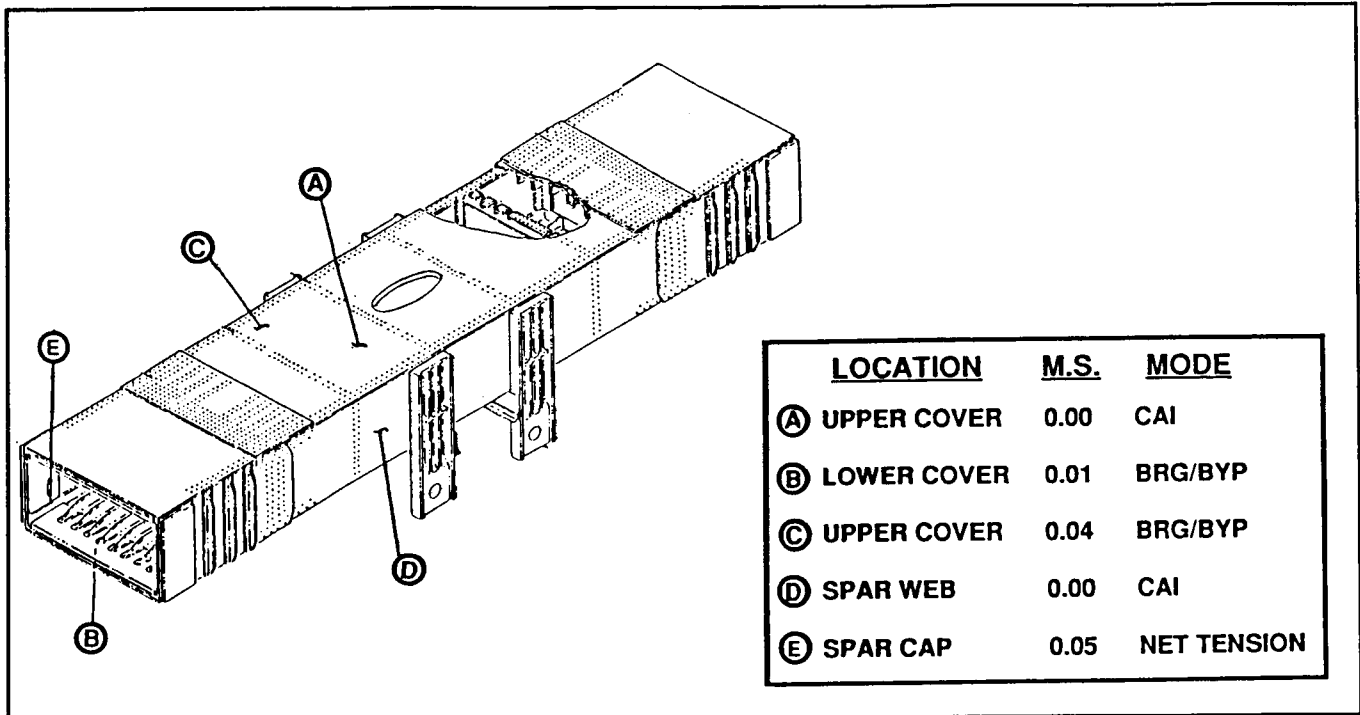

Figure 7. Minimum Margins of Safety

BOX BEAM TEST PROGRAM

Box Beam Test Set-Up

Since the box beam was tested for combined bending and torsion loads, metal extensions were attached to the ends of the composite material box to obtain the desired vertical shear and bending moment distributions. As shown in Figure 8, the vertical shear loads were applied by two hydraulic jacks at each end of the beam. These loads were reacted at the four mainframe locations near the center of the beam. Axial strain gages, rosette strain gages and deflection gages were utilized to measure the deflections and strains of the box beam during the tests. Strain gages were also applied to the reaction struts to measure the vertical shear load reactions.

Stiffness Tests

After conducting an upbending test to 20 percent of design ultimate load to verify the performance of the instrumentation, a series of stiffness tests were performed. For these tests, the box beam was loaded to 30% of design ultimate for the upbending, downbending and torsion design conditions. Deflection gages, mounted spars at various positions along the span were used to measure the vertical displacements of the test specimen. For the beam bending conditions and the torsional loading condition the deflections agreed with the predicted values. The results of these tests verified that the design met or exceeded the stiffness requirements for the center wing box.

Strength Tests

The test plan for strength verification included the following: a) limit load downbending plus torsion, b) limit load upbending plus torsion, c) ultimate load upbending plus torsion, and d) a residual strength to failure test with upbending plus torsion loads after the box had been impact damaged in several locations. Premature failure of the box beam occurred at 125% of the design limit load during the ultimate load test condition. The following paragraphs will discuss the test results obtained and describe the box failure.

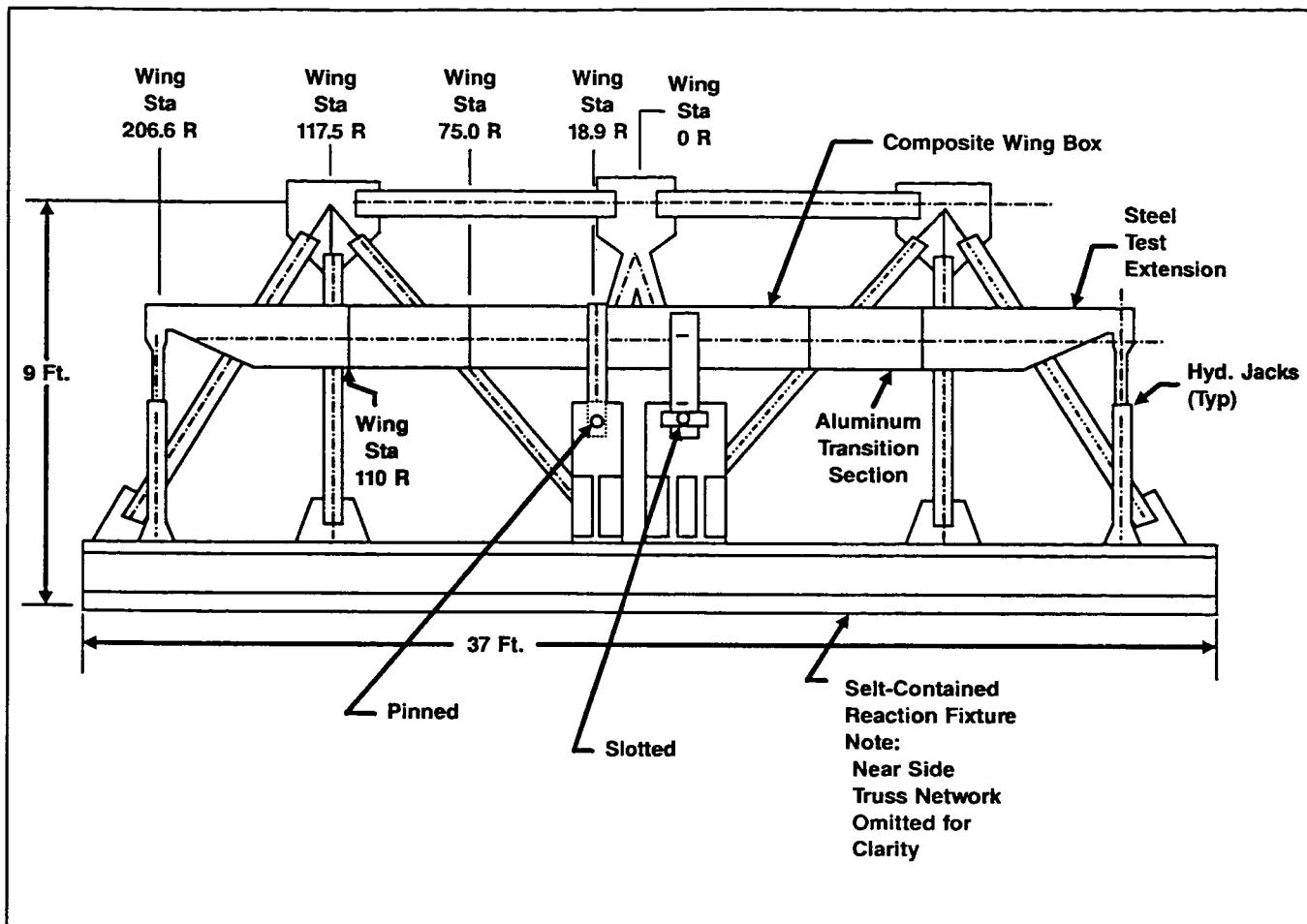

Figure 8. Box Test Set-up

For the downbending combined with torsion condition, the box was loaded to limit load. A review of the load-strain data indicated that the maximum strains, which were less than 3000 micro inch/inch, were slightly greater than predicted. No indications of local buckling were detected; however, local bending strains of the upper cover panels in the vicinity of the access hole and hat stiffeners were slightly greater than anticipated.

An upbending combined with torsion loading condition was conducted to limit load followed by the ultimate load test for the same combined load condition. During the ultimate load test the box failed at 125% of design limit load. The failure location was in the upper cover and spars at wing station 45. Figure 9 presents the average axial loads for the upper and lower covers and the axial strains in the covers at the failure load. The measured strains are the averages for the gages mounted back-to-back on the cover skin located approximately 4 inches from the spar web. Compared to strains predicted by finite element analysis, the measured strains are considerably greater in the mid-span locations of the box. From W.S. 30 inboard, the measured strains on the lower cover were 16 percent greater than predicted and 22 percent greater than predicted on the upper cover.

A review of the load-strain information for the upbending condition indicated that no local buckling occurred in the covers or spars prior to failure. However, as shown in Figure 10, a significant amount of local bending was measured in the central section of the upper cover in the area surrounding the cutout. The 5500 microinch/inch compressive strain recorded near the edge of the cutout was also the largest strain measured on either upper or lower covers. Most of the local bending which occurred in this region is due to the axial load path eccentricity caused by the access hole and its reinforcement.

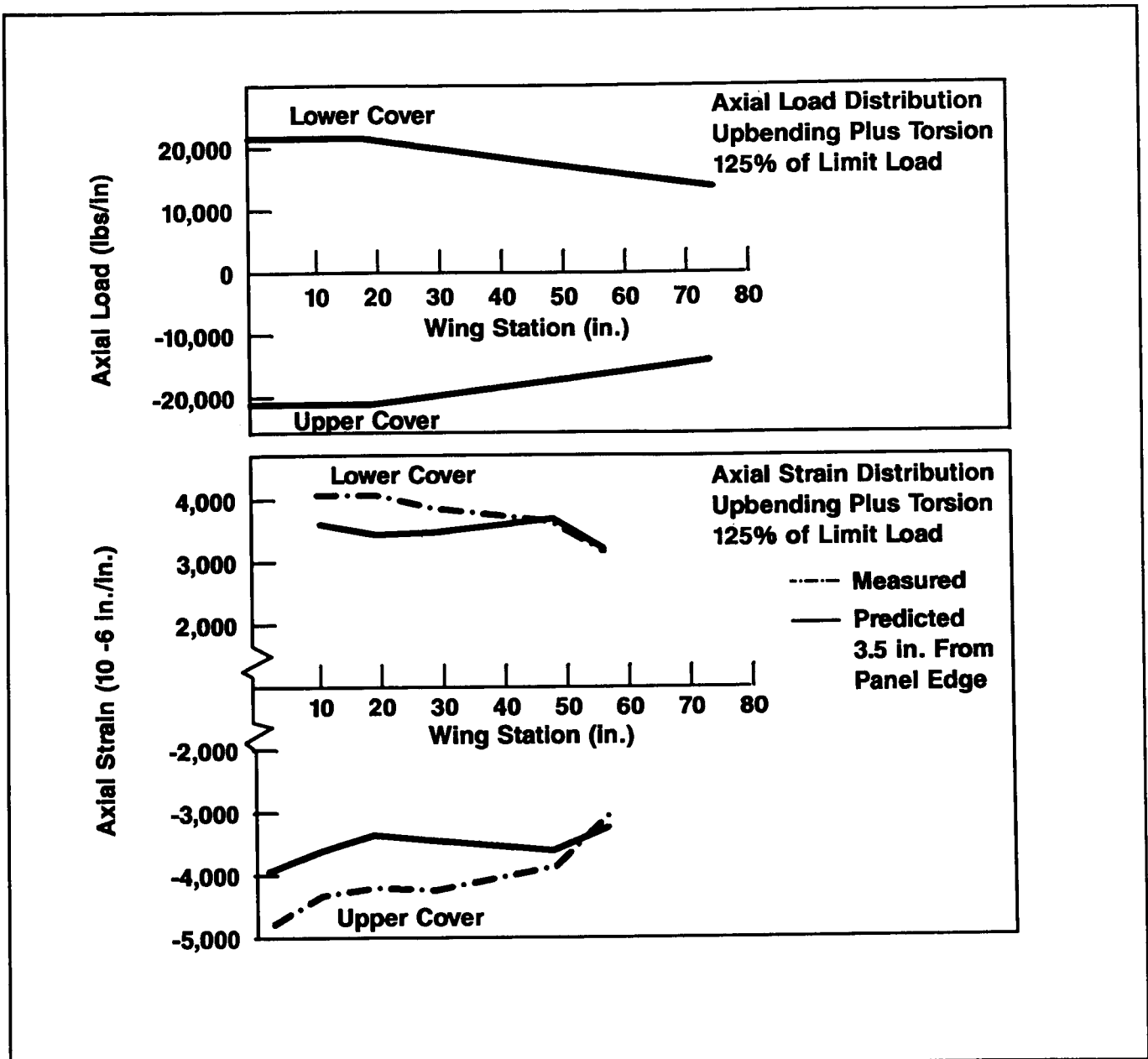

Figure 9. Cover Loads and Strains at Box Failure Load

Failure of the upper cover occurred at W.S. 45. The failure location and axial strains measured in the location just prior to failure are shown in Figure 11. Note that all of these strains are much less than the compression design allowable for the cover material, and as shown previously in Figure 9 are close to predicted values. However, the hat runout at the rib cap does cause a load path eccentricity in the central section of the cover which causes a local bending moment as indicated by the strains measured on the skin and hat crown gages at W.S. 31.5. It is hypothesized that local bending on the skin laminate at the hat runout precipitated failure of the upper cover through the last row of fasteners attaching the hat flanges to the skin. Figure 12 shows the upper cover failure as viewed from outside of the box. The photograph in Figure 13 presents the upper cover failure viewed from inside the box. Note that the modes of failure seen in the cover skin and blade stiffeners were similar to those seen in stiffened panel tests previously conducted to evaluate compression load carrying performance of this type of construction.

A review of the load-strain plots for the front and rear spars indicated no local buckling had occurred prior to failure. Measured strains on the front spar web at the failure load, shown in Figure 14, averaged 18 percent greater than the predicted values at W.S. 10 and W.S. 27.5. At W.S. 48 the measured strains were equal to the predicted strains. Note that the maximum strain at plus/minus 45 degrees on

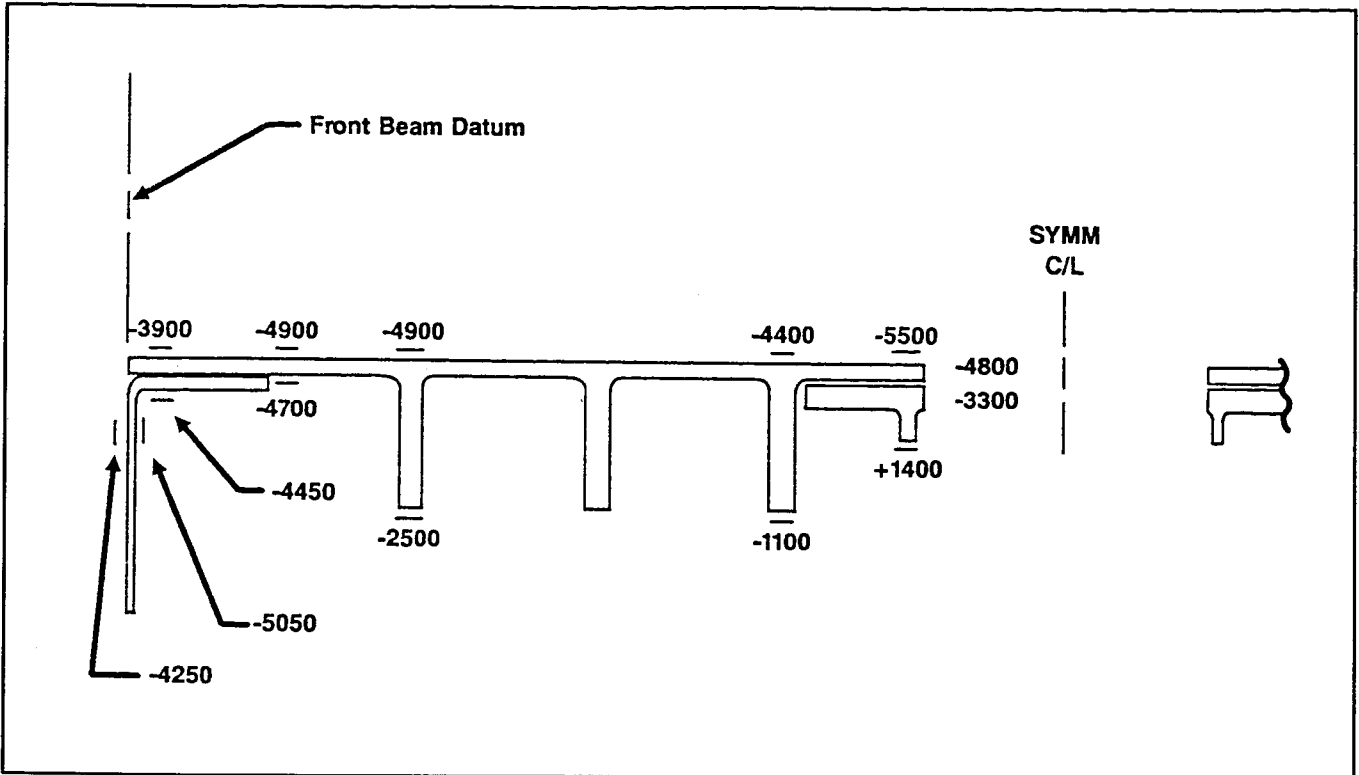

Figure 10 Measured Axial Strains of Upper Cover at W.S. 0 at Failure Load (All Strains 10^{-6} In./In.)

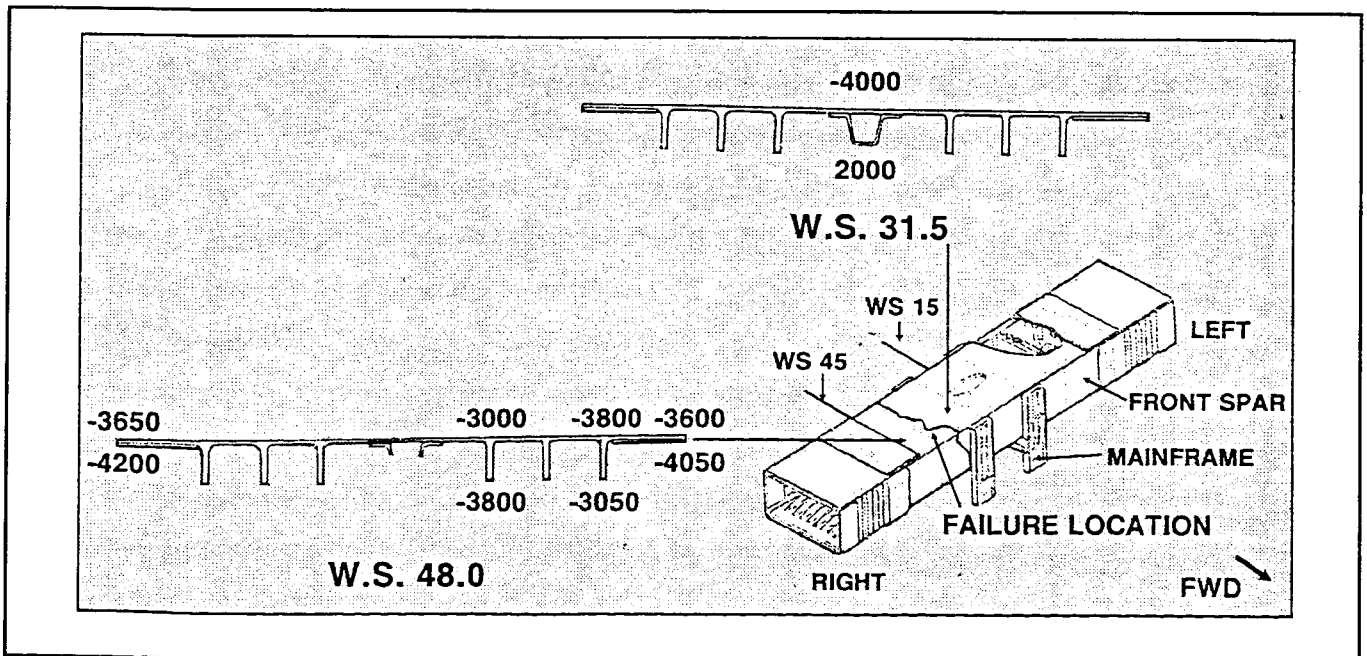

Figure 11. Axial Strains Near Failure Location (All Strains are 10^{-6} In./In.)

the web is -2500 microinch/inch. Figure 15 shows the failure of the front spar web which starts at the upper cap at about W.S. 42 and runs to the edge of the mainframe at W.S. 25. The failure of the rear spar was similar to that shown for the front spar.

Post Test Investigations

Upon completion of the test program, a review was made of the load-strain data, and the box failure locations were visually inspected from the exterior and interior of the box. For the no-impact damage condition, structural analysis had predicted that the minimum margin of safety for the upper cover was at W.S. 45 for a bearing/bypass failure mode at the cover to spar cap joint (see Figure 7). However, all of the axial strains measured near the failure location, previously presented in Figure 11, were considerably less than the average open hole compression strength for this material and laminate orientation. A review of the inspection records indicated there were no anomalies in the covers or spars at the failure location. The spar cap and spar web had higher margins of safety than the cover at this location.

Additional structural analysis, quality assurance tests and panel tests are being conducted on the box to determine the cause of the premature failure. Analysis completed to date points to the hat runout as the most likely detail which initiated the failure.

CONCLUDING REMARKS

Design studies indicated that the use of advanced composites for construction of a transport wing box would result in a 25 percent weight savings compared to a metal wing box. A full-scale section of the composite wing was designed in detail, analyzed, fabricated and tested. The box failed prematurely at 125 percent of design limit load during the combined upbending and torsion ultimate design load test. Based on the post test investigations completed thus far, it appears that the failure initiated at a hat

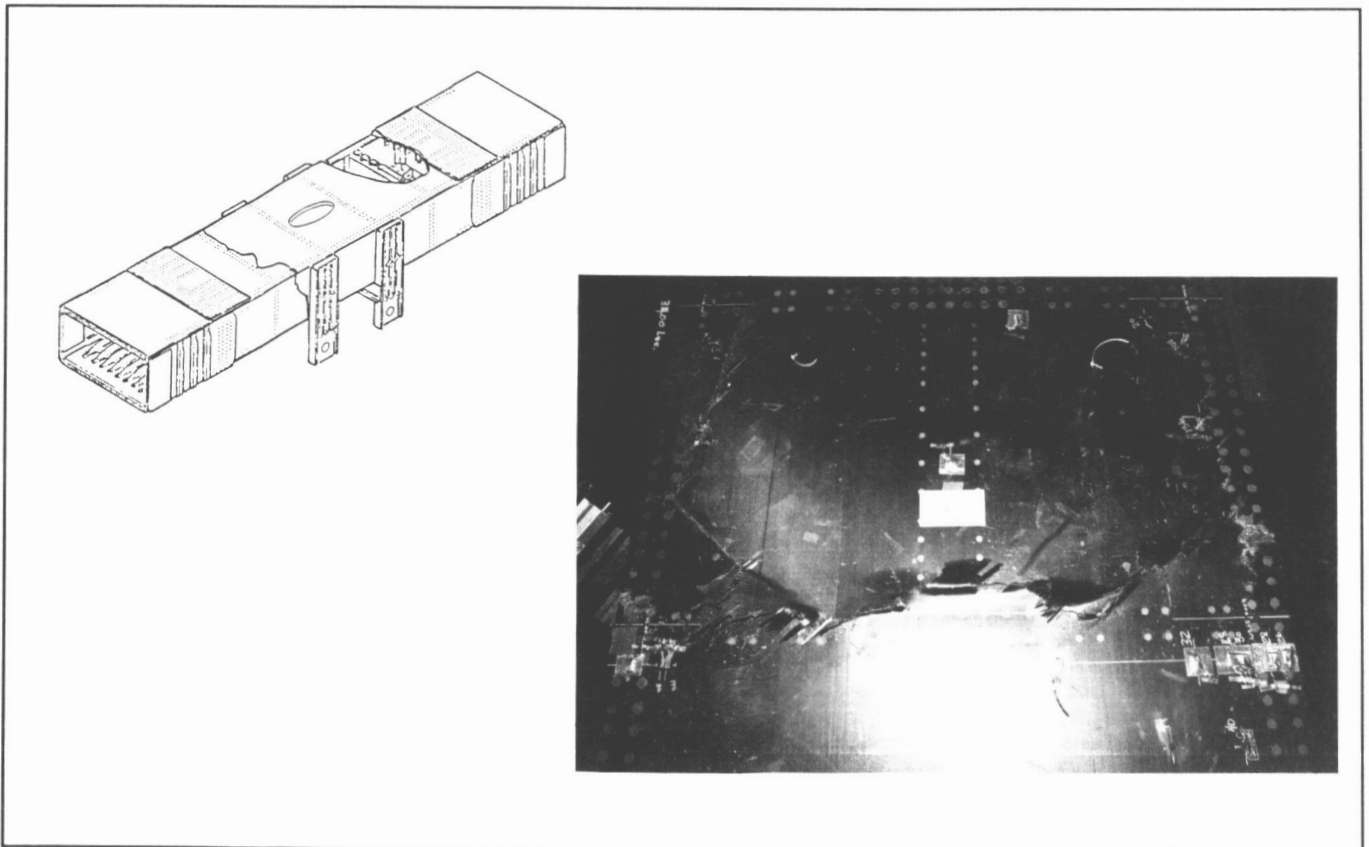

Figure 12. Upper Cover Failure at W.S. 45

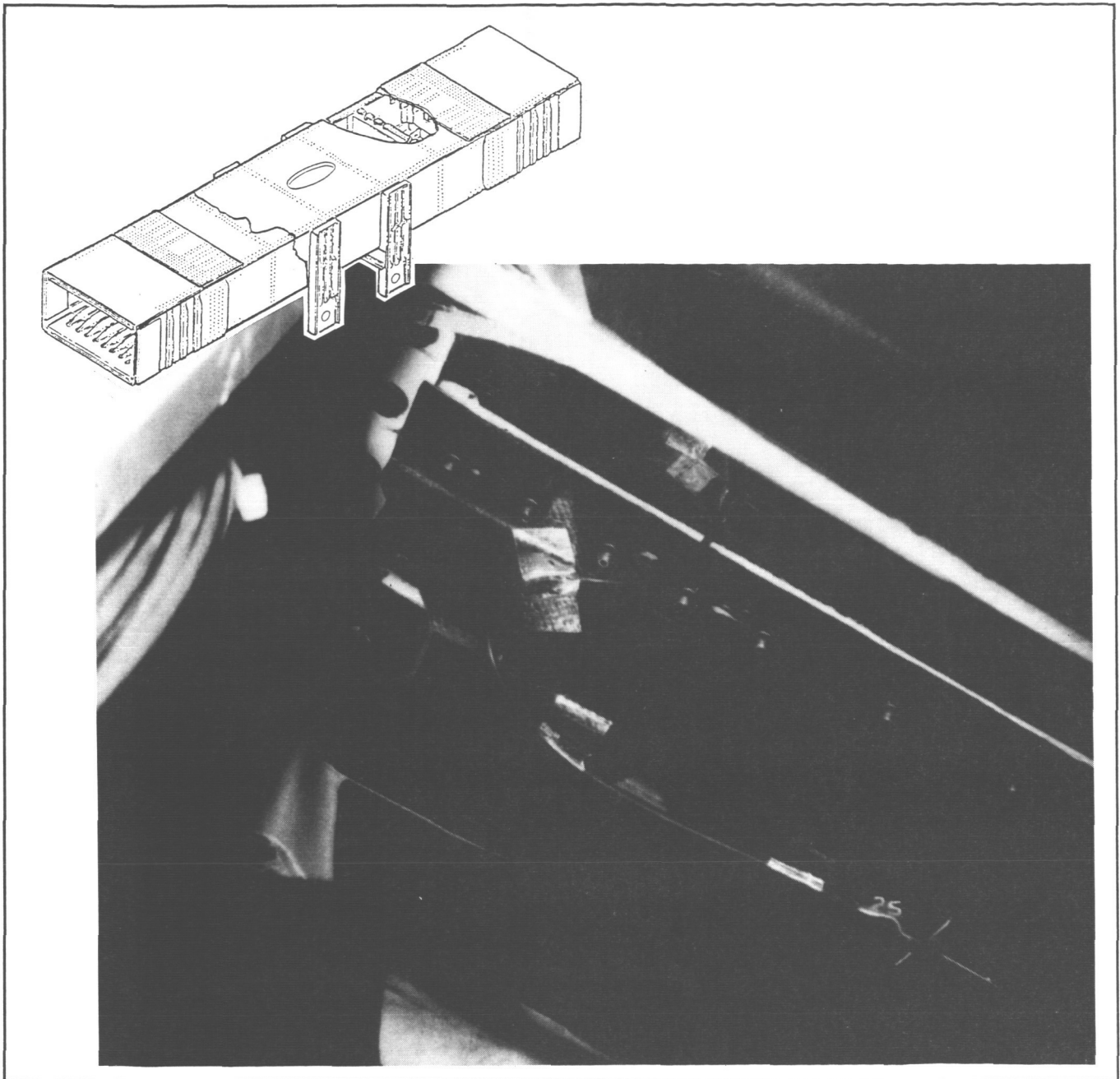

Figure 13. Interior View of Upper Cover Failure at W.S.. 45

stiffener runout in the central section of the cover. It is hypothesized that the load path eccentricity at the stiffener runout caused higher than predicted local bending stresses which resulted in a premature failure in the upper cover. Additional structural analysis and tests are continuing to substantiate this hypothesis.

In addition to the suspected design detail problem at the hat runout in the upper cover, data from the test program also indicated a local bending around the access hole in the upper cover. The access hole reinforcement design concept should be revised to minimize the load path eccentricities in that area. Another design change recommended is to use an intermediate modulus fiber such as IM7 in place of the AS4 for the spanwise plies in the covers and spar caps. Trade studies have indicated that this change would result in a substantial weight savings compared to the current design and more than offset the weight added to modify the design details associated with the hat stiffener runout and access hole reinforcement.

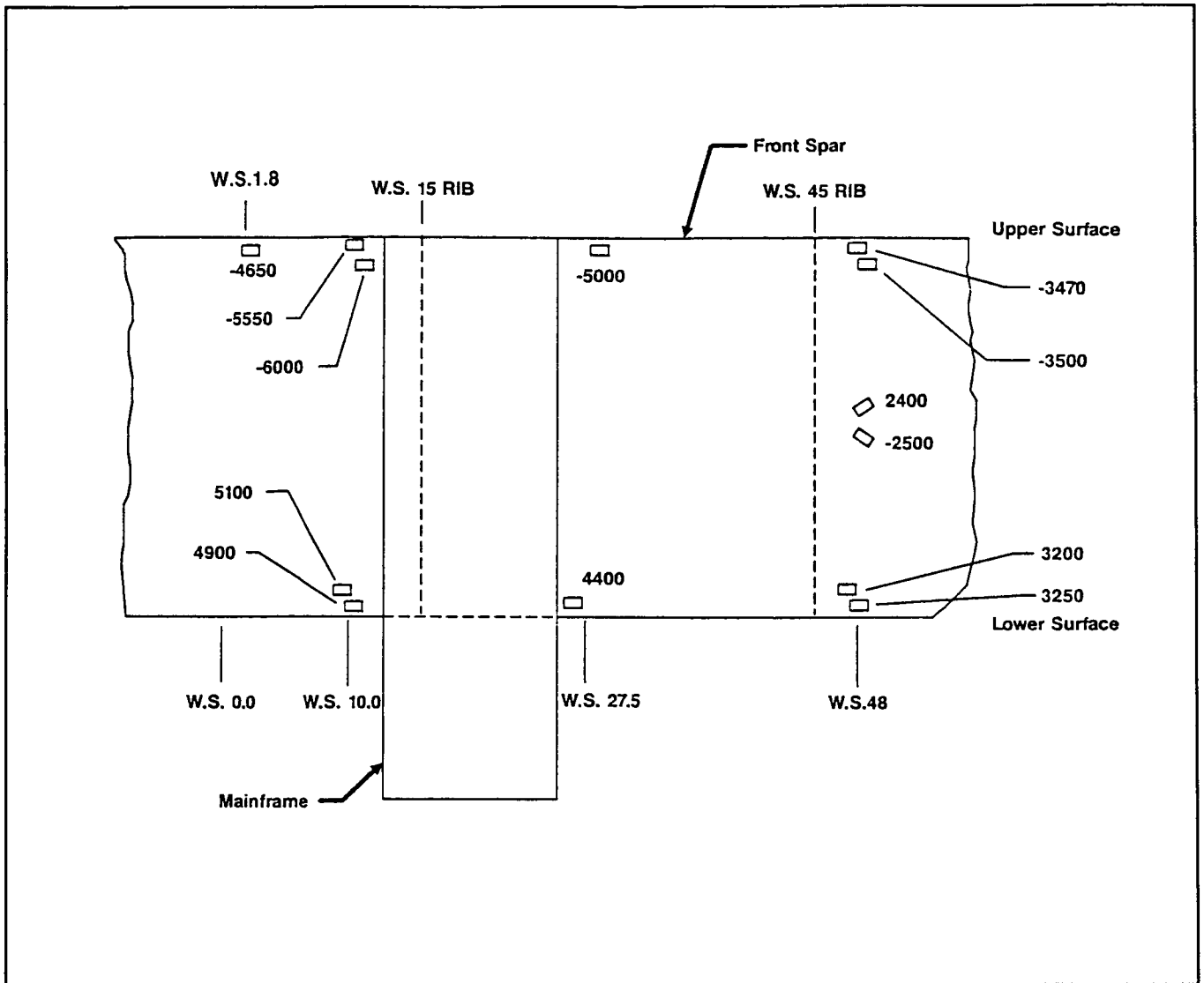

Figure 14 Front Spar Measured Strains at Failure Load

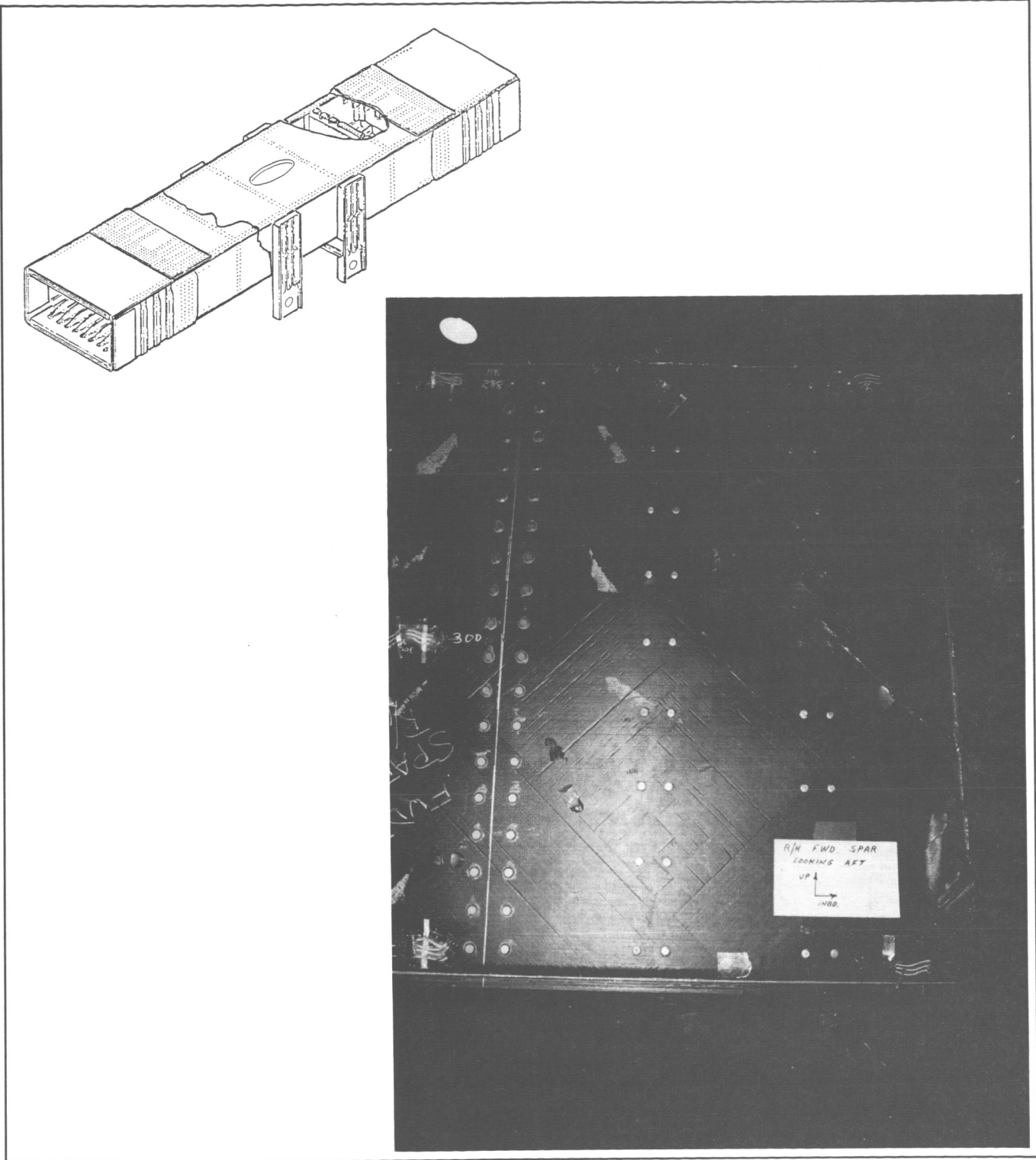

Figure 15. Exterior View of Front Spar Failure