

COMPARISON OF RESIN FILM INFUSION,
RESIN TRANSFER MOLDING AND
CONSOLIDATION OF TEXTILE PREFORMS
FOR PRIMARY AIRCRAFT STRUCTURE

J. Suarez and S. Dastin
Grumman Aircraft Systems
Bethpage, NY

NASA
515-24
51355
P-32

SUMMARY

Under NASA's Novel Composites for Wing and Fuselage Applications (NCWEA) Program, Grumman is developing innovative design concepts and cost-effective fabrication processes for damage-tolerant primary structures that can perform at a design ultimate strain level of 6000 micro inch/inch ($\mu\text{in./in.}$). Attention has focused on the use of textile high-performance fiber-reinforcement concepts that provide improved damage tolerance and out-of-plane load capability, low-cost resin film infusion (RFI) and resin transfer molding (RTM) processes, and thermoplastic forming concepts. The fabrication of wing "Y" spars by four different materials/processes methods is described: "Y" spars fabricated using IM7 angle interlock 0-/90-deg woven preforms with ± 45 -deg plies stitched with Toray high-strength graphite thread and processed using RFI and 3501-6 epoxy; "Y" spars fabricated using G40-800 knitted/stitched preforms and processed using RFI and 3501-6 epoxy; "Y" spars fabricated using G40-800 knitted/stitched preforms and processed using RTM and Tactix 123/H41 epoxy; and "Y" spars fabricated using AS4(6K)/PEEK 150-g commingled angle interlock 0-/90-deg woven preforms with ± 45 -deg commingled plies stitched using high-strength graphite thread and processed by consolidation. A comparison of the structural efficiency, processability, and projected acquisition cost of these representative spars is presented.

INTRODUCTION

A wider application of state-of-the-art composites to primary aircraft structure has been inhibited by the materials' intrinsic low damage tolerance, low fracture toughness, low notch strength, and low out-of-plane strength. In addition, the materials' high acquisition cost and high manufacturing costs have not helped. To overcome these deficiencies, we have embarked on a NASA-sponsored program to develop damage-tolerant primary structures that can operate at a design ultimate strain level of 6,000 $\mu\text{in./in.}$ via innovative design concepts and cost-effective fabrication processes.

The NCWEA Program is performed by Grumman Corporation Aircraft Systems Division and its subcontractors, Textile Technologies, Inc., and Composittek Corporation, under the sponsorship of NASA Langley ✓

Research Center (LaRC), Hampton, VA 23665-5225. Mr. H. Benson Dexter is the NASA/LaRC Contracting Officer Technical Representative.

OBJECTIVE

The primary objective of the NCWFA Program is to integrate innovative design concepts with cost-effective fabrication processes to develop damage-tolerant primary structures that can perform at a design ultimate strain level of 6000 $\mu\text{in./in.}$ This is being investigated through: (1) optimum wing and fuselage design concepts; (2) the use of textile processes with high-performance fiber architecture that provide improved damage tolerance and durability, high-notch strength and increased out-of-plane load capability; and (3) the use of cost-effective fabrication processes such as RTM, RFI, and consolidation forming of hybrid Gr/Ep fiber forms.

WING DESIGN CONCEPTS

To achieve the objective of the NCWFA Program, innovative composite design concepts were incorporated into the baseline wing. The baseline aircraft selected for this program is a subsonic patrol VSTOL, Grumman design 698-420. This design is a high-wing, T-tail, turn-tilting nacelle configuration that combines both power plant and control vanes immersed in the fan stream. The wing has a span of 44 ft and a fold span of 16 ft and is sized to allow installation of the conformal radar. The thickness ratio is 14% at the root and 12% at the tip, with a maximum depth of 14.4 in. at the centerline. Fuel is carried in the wing box from fold joint to fold joint. Roll control in conventional flight is provided by spoilers mounted on the rear beam.

The multi-spar and multi-rib structural arrangement considered spar/stiffener orientation, spar/stiffener spacing, and rib pitch. The structural geometry was varied to achieve a least-weight/cost cross-section of detail structural elements. For the multi-spar structural concepts, the two types of wing cover configurations that were evaluated have the potential of successfully increasing the working strain to levels at least 50% higher than those of the baseline. The two types evaluated were plain panel-spread and discrete cap. The plain panel-spread is essentially a monolithic skin of approximately constant thickness at any chordwise cut. In addition, the laminate consists of the same family of lamina orientations (0, 90, and ± 45 -deg) at any point. The second type, discrete cap, utilizes a skin of two distinct laminate orientations. Between spars, the skin panel consists of a high-strain-to-failure laminate of 90- and ± 45 deg layers. The absence of 0-deg layers in this panel has two additional advantages: first, for a given thickness, it will possess a higher resistance to buckling loads; second, the laminate's EA (extensional stiffness) is very low as compared to the total section, resulting in a lesser axial load applied to the unsupported segment of skin. At each spar, 0-deg layers are added to the panel laminate, resulting in a local pad. The

0-deg layers provide the axial filament control to the laminate and carry the preponderance of axial load. Located over the spar, the high loads are rigidly supported minimizing any instability problems. For the multi-rib concepts, stiffeners parallel to the front spar were selected as the preferred stiffener orientation because of relatively high structural efficiency and potential ease of manufacture.

The development of combined material/configuration concepts involved the use of Y spars and Y stiffeners to support the covers. The basic philosophy in using Y spars is that they reduce panel widths and required thickness on the upper cover. Although an increase in weight is expected for the intermediate spars, the weight savings produced by the upper cover will adequately compensate for it, and yield an overall weight savings. For all Y-spar designs, the angle was set at 120 deg to provide equilibrium and balance. The distance between the legs of the Y spar at the attachment to the upper cover depends on the spar spacing. To obtain the maximum benefit from the Y-spar configuration, the fastener spacing is half that of the spar. The weight savings generated by these concepts showed significant improvement over the baseline. The multi-rib design, using G40-800/F584 with Y stiffeners, provided the greatest savings (573 lb, or 46% of the metal torque box weight of 1233 lb). The multi-spar design using Y spars and discrete caps was a close second in weight savings (537 lb, or 44% of the metal torque box weight). Each design concept was rated in terms of the following parameters: weight risk, manufacturing and production costs, durability/damage tolerance, repairability, inspectability, and operation and support costs before the final selection.

Y-SPAR SELECTION

Based on the results of the evaluation of the combined material/configuration concepts, the Y spar was selected for further study. A Y spar representative of an intermediate wing spar segment in size, complexity, and load-carrying capability (shear flow of 1,015 lb/in. in five-spar wing configuration) was designed (figure 1). The material preforms were:

- Three 40-in. Y spars woven by Textile Technologies, Inc. (TTI) on NASA Jacquard loom using angle-interlock fiber architecture
 - Commingled AS4 (6K)/PEEK 150-g Tows
 - 0-/90-deg weave and ± 45 -deg fabric stitched with Fiberglass/Toray H.S. thread
- Four 40-in. Y spars knitted/stitched by Compositek Corporation using G40-800 fiber
- Four 40-in. Y spars woven by TTI on NASA Jacquard loom using angle-interlock fiber architecture
 - IM7 (12K) Tows
 - 0-/90-deg weave and ± 45 -deg fabric stitched with Fiberglass/Toray H.S. thread.

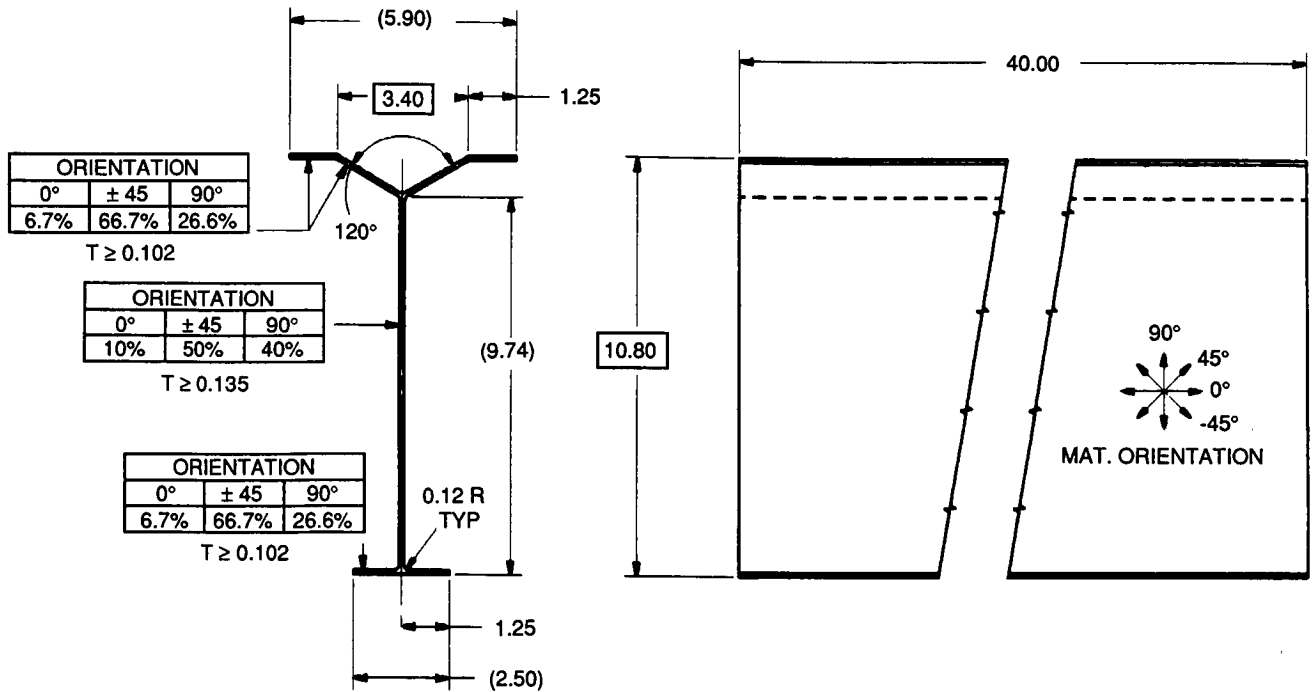

R91-6880-001

Figure 1 Y-Spar Configuration

MANUFACTURING EFFORT OVERVIEW

- Commingled AS4/PEEK 150-g Y spars
 - Design and fabrication of woven commingled AS4/PEEK 150-g Y-spar preforms
 - Consolidation/forming of Y-spar preforms
 - NDI and dimensional analysis of Y spars
 - Structural test of Y spar
- G40-800/3501-6 Gr/Ep Y spars
 - Design and fabrication of knitted/stitched G40-800 preforms
 - RFI/autoclave-processed Y-spar preforms
 - NDI and dimensional analysis of Y spars
 - Structural test of Y spar
- G40-800/Tactix 123 Gr/Ep Y spars
 - Design and fabrication of knitted/stitched G40-800 preforms
 - RTM processed with Tactix 123/H41
 - NDI and dimensional analysis of Y spar
 - Structural test of Y spar
- IM7/3501-6 Gr/Ep Y spar
 - Design and fabrication of IM7 12K angle-interlock woven Y-spar preforms
 - RFI/autoclave-processed Y spar
 - NDI and dimensional analysis of Y spar
 - Structural test of Y spar.

CONSOLIDATION OF WOVEN COMMINGLED Y SPARS

The effort involved the consolidation (thermoforming) of three woven/stitched AS4 6K/PEEK 150-g Y spars. The architecture of the woven commingled AS4/PEEK 150-g 0-/90-deg preforms is presented in figure 2. The preform webs consist of 76.59% fill yarns, 19.16% warp stuffers, and 4.25% through the thickness warp weavers. The preform flanges consist of 75.00% fill yarns, 18.75% warp stuffers, and 6.25% through the thickness warp weavers. The PEEK resin in these preforms was commingled in the proper proportion with the AS4 graphite fiber yarns prior to weaving and stitching.

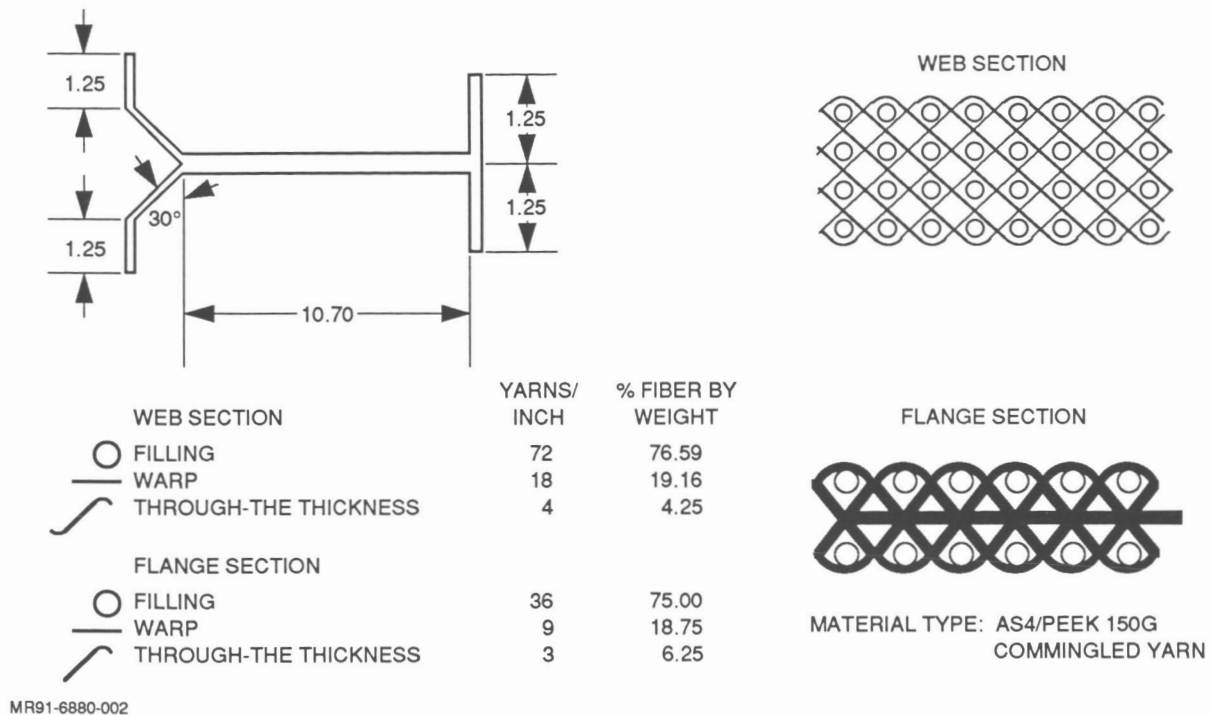

Figure 2 Architecture of Woven Commingled AS4/PEEK 150G 0-/90-Deg Preform

The 0-/90-deg carcasses were first woven by TTI on a Jacquard loom. Next, the ± 45 -deg ply material was located on the outside faces of both the webs and the flanges of the completed carcasses and semi-automatically stitched in place by Sewing Machine Exchange (SMX), Chicago, IL, using Toray T900-1000A fiber. The completed preforms were then shipped back to TTI for inspection; then to Grumman for consolidation.

Because of errors in the loom setup, the preforms were dimensionally incorrect. The 0-/90-deg carcasses were woven at 22 picks per inch (ppi) instead of 11 ppi, as required. In addition, the web height was 10.7 in., instead of 9.7 in., as specified.

The required 45-/135-deg fabric reinforcement was stitched to the woven 0-/90-deg commingled AS4/PEEK 150-g Y-spar carcasses by SMX (figure 3). The preform was stitched using a cross-hatch pattern with a row spacing of 1/4 in. In the radius areas, however, three rows of stitches were installed, with a row spacing of 1/8 in.

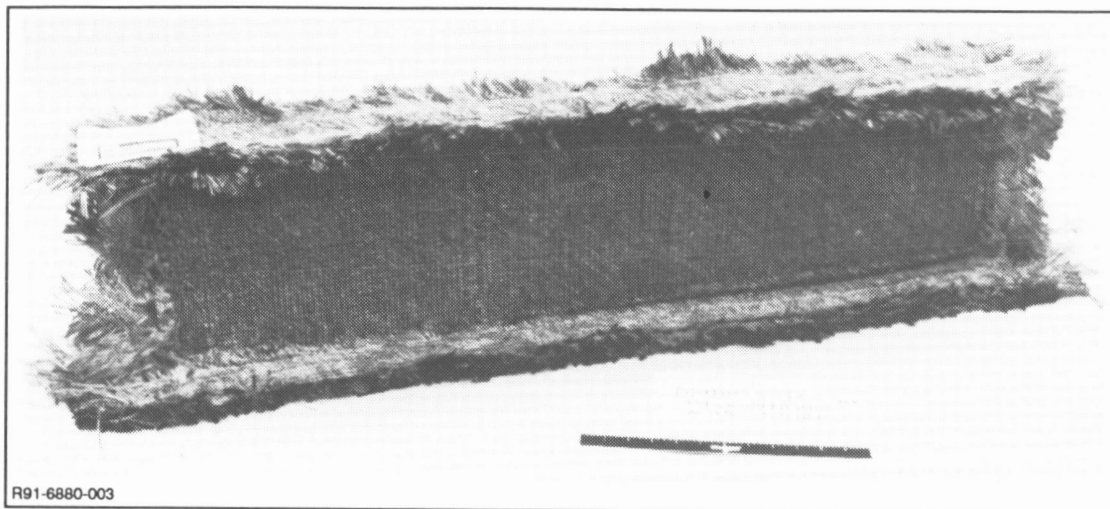

Figure 3 Preform of Woven 0-/90-Deg Commingled AS4/PEEK with Stitched 45-/135-Deg Fabric

It was intended that the preform be stitched using only Toray T-900-1000A carbon fiber; SMX, however, required the use of fiberglass loops in combination with the carbon fiber thread in the radii and flanges of the preform. The carbon stitching equipment was too large to be conveniently used for the Y-spar flanges. In addition, this equipment lacked the sensitive feeding characteristics required for the flange stitching operation. Ultimately, the Y-spar preform flanges were stitched manually.

Monolithic graphite was chosen for the tooling, based on the following advantages over more conventional materials:

- Coefficient of thermal expansion (CTE) near that of the part
- Fairly high thermal conductivity
- Excellent surface finishes possible for good part finish and ease of release
- Relatively low cost.

The tool consists of four machined details: two matching left and right halves for the web, and top and bottom details for the flanges. The tool's details are pictured in figure 4.

The consolidated commingled AS4/PEEK 150-g woven/stitched Y spar was consolidated for 4 hr at 720°F ($\pm 10^\circ$), 160 psi fluid pressure, plus full vacuum bag pressure. The prolonged hold at elevated temperature was required to accommodate the relatively large mass of the monolithic graphite mandrels that acted as heat sinks. In production, integrally

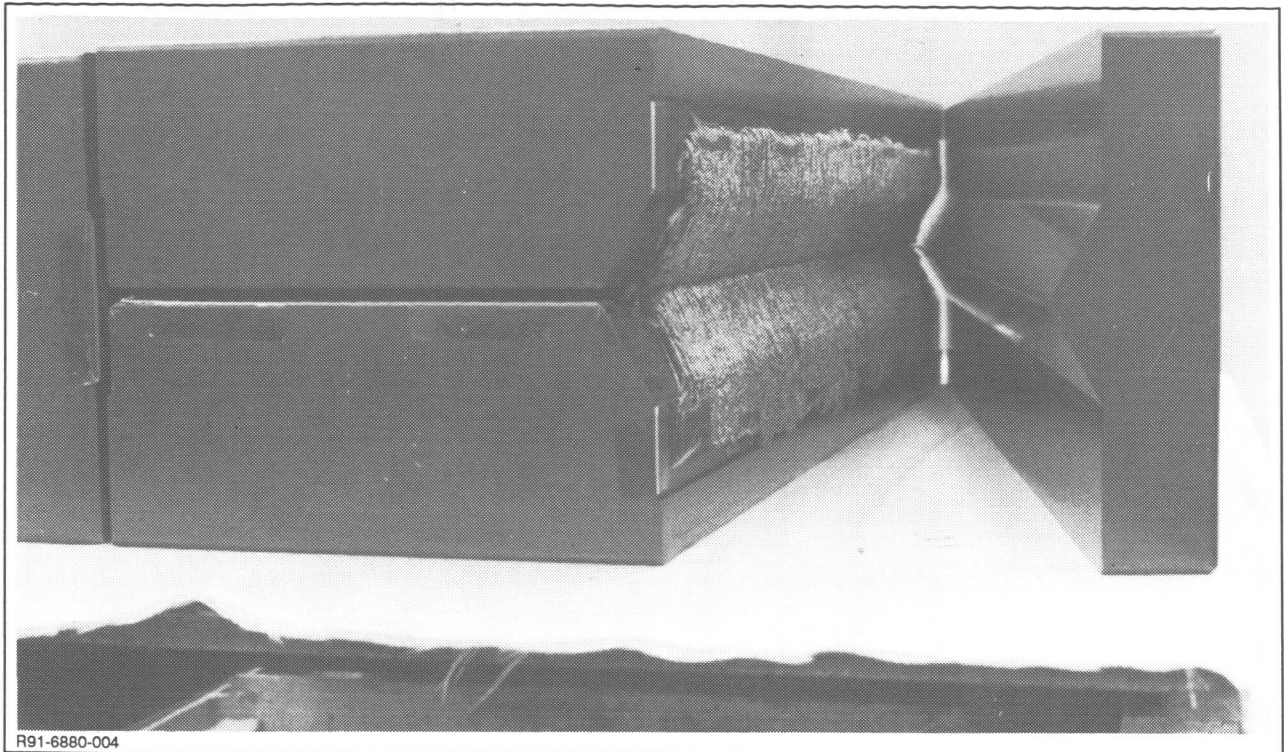

Figure 4 AS4/PEEK Y-Spar Preform in Graphite Tool

heated and cooled tools would be used in combination with cold-wall autoclave procedures to provide a low-cost consolidation methodology. The high-temperature autoclave run was performed without any processing difficulties. The consolidated Y spar was visually acceptable (figure 5).

All three completed spars were ultrasonically inspected for voids. Both the first and third spars processed showed several minor void areas--particularly in the flanges--whereas the second spar tested almost void-free, with only small areas of interstices in the angular sections of the Y flanges. Based on these results, all further testing was done on the second Y spar only.

Resin content and fiber volume determinations for the consolidated Y spar where:

- Percent fiber volume - 56.1
- Percent resin volume - 42.8
- Percent void volume - 1.1.

Figure 6 presents a comparison of the three spars' target, preform, and final part dimensions. (The target dimensions are adjusted for the oversize and overthickness conditions of the preforms.) Also given in the figure is the percentage of consolidation for each Y spar. This is a measure of how the bulk factor of each preform related to each finished part's final thicknesses. Ideally, the consolidation percentages should be fairly closely matched within each part and among the three parts.

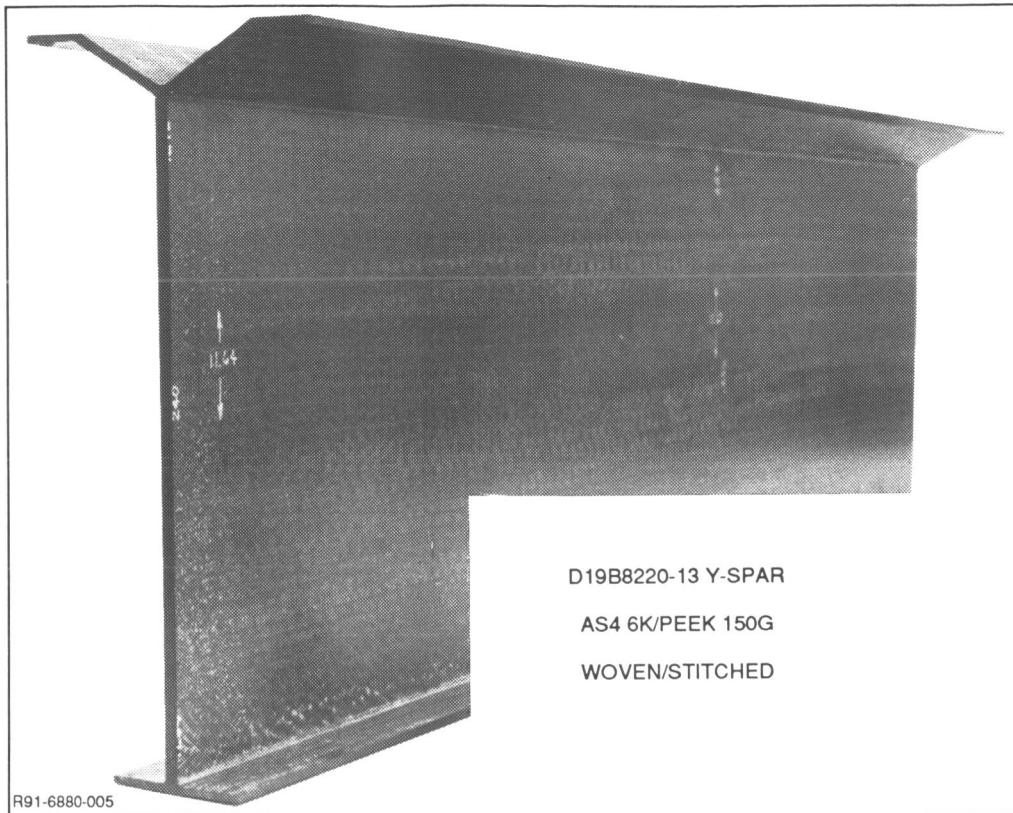
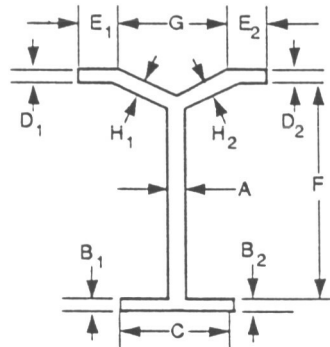

Figure 5 Consolidated Y Spar



DIM	TARGET DIM (IN.)	Y-SPAR S/N-1			Y-SPAR S/N-2			Y-SPAR S/N-3		
		PRE-FORM (IN.)	CONS. SPAR (IN.)	PERCENT CONS. (%)	PRE-FORM (IN.)	CONS. SPAR (IN.)	PERCENT CONS. (%)	PRE-FORM (IN.)	CONS. SPAR (IN.)	PERCENT CONS. (%)
A	0.215	0.463	0.242	47.7	0.458	0.240	47.6	0.438	0.238	45.7
B1	0.151	0.381	0.134	64.8	0.315	0.123	61.0	0.334	0.126	62.3
B2	0.151	0.350	0.127	63.7	0.313	0.119	62.0	0.375	0.126	66.4
C	2.50	2.74	2.50	N/A	2.67	2.50	N/A	2.36	2.40	N/A
D1	0.151	0.366	0.156	58.2	0.366	0.160	56.3	0.357	0.157	56.0
D2	0.151	0.397	0.141	64.5	0.352	0.142	59.7	0.382	0.143	62.6
E1	1.25	-	0.90	-	-	0.70	-	-	0.70	-
E2	1.25	-	1.00	-	-	0.90	-	-	0.70	-
F	11.65	-	11.65	-	-	11.65	-	-	11.61	-
G	3.40	-	3.34	-	-	3.40	-	-	3.36	-
H1	0.151	0.366	0.170	53.6	0.366	0.156	57.4	0.357	0.156	56.3
H2	0.151	0.397	0.158	60.2	0.352	0.153	56.5	0.382	0.152	60.2

MR91-6880-006

Figure 6 Comparison of Consolidated Preforms S/Ns 1, 2, and 3 Target, Preform, and Final Part Dimensions

Again, the second spar--S/N 2--provided the best results dimensionally. With the exception of the web thickness (letter A, of 0.240 in.) and a consolidation percentage of 47.6, the other thickness dimensions have consolidation percentages between 56.3 and 62.0. This is the tightest range of the three spars, and is reflected in the better NDI results mentioned earlier. The raw dimensions of spar S/N 2 also are the most consistent among the three spars. Both the angular and horizontal areas of the Y flange (for example, letters D1, D2, H1 and H2) have thicknesses ranging from 0.142 to 0.160 in. And although the thicknesses of the two legs of the T flange (letters B1 and B2) are somewhat less (0.123 and 0.119 in., respectively), this condition exists in all the spars. It is a reflection of the greater thickness of all the preforms in the Y end.

With regard to the spars' web thicknesses (letter A, of 0.242, 0.240, and 0.238 in., respectively) and their corresponding low consolidation percentages, it is apparent that the bulkiness of the preforms' webs, combined with the large area of web, made it impossible to compact these areas down to the target value of 0.215 in.

RFI OF KNITTED/STITCHED Y SPAR

Four G40-800 knitted/stitched graphite Y-spar preforms were fabricated by Composittek Corporation. The Y-spar architecture was:

- Flanges:
 - 0 deg, 6%
 - ± 45 deg, 55%
 - 90 deg, 39%
- Web:
 - 0 deg, 9%
 - ± 45 deg, 62%
 - 90 deg, 29%.

Three of the knitted/stitched preforms were (RFI) impregnated and autoclave processed using Hercules 3501-6 resin film. In this proprietary process, resin in film form is positioned within the fiber preform as the preform is being constructed. The fiber and resin are then heated in a vacuum chamber, thus impregnating the preform by gravity and capillary wetting. During the infusion, the vacuum is pulsed to remove entrapped air and volatiles from the resin.

The impregnated preform was then to be processed by Composittek using their Autocomp technique. This proprietary procedure combines aspects of compression molding and autoclave molding in one process. The preform is installed in an integrally heated, matched mold, and the setup is located inside a reusable vacuum bag contained with the Autocomp pressure vessel. Vacuum is then drawn on the part while the tool is heated. At the proper temperature for the particular resin system, vacuum is shut down and fluid pressure is applied to fully close the tool, and to complete the part's processing. Due to setup problems with Composittek's Autocomp pressure vessel and related

equipment, the three spars were conventionally consolidated in an autoclave.

From an initial visual standpoint, RFI S/N 1 was of poor appearance overall, with large, obviously dry areas throughout the spar. On the other hand, both RFI S/Ns 2 and 3 looked quite good, with no apparent bad areas. As a result, it was decided to further analyze only RFI S/Ns 2 and 3; no further examinations or analyses were made of RFI S/N 1. Figure 7 shows the completed Y spar RFI S/N 2.

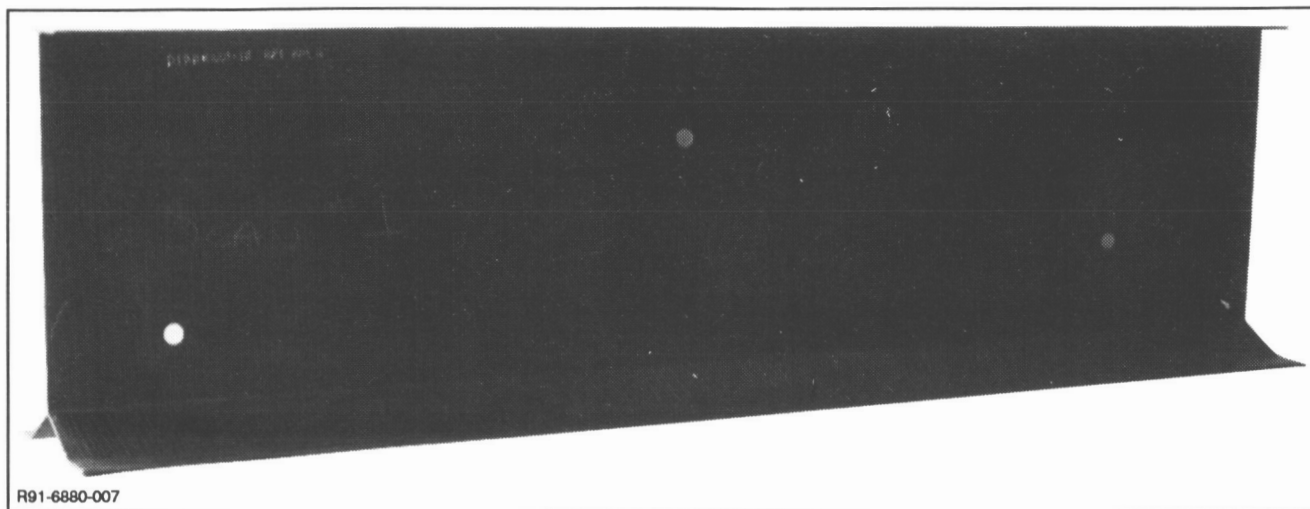

Figure 7 RFI S/N 2 G40-800/3501-6 Y Spar

Both RFI S/Ns 2 and 3 were ultrasonically inspected via C scan, with results indicating that RFI S/N 2 was void free, and that RFI S/N 3 contained only a small void in one horizontal leg of the Y flange.

Figure 8 compares the target and part dimensions of RFI S/Ns 2 and 3. It is apparent that although the spars are dimensionally consistent, they are both thicker than as targeted (with the exception of dimensions H1 and H2, the angular component of the Y flange, which in both parts is slightly undersize). Whether this general oversizing is due to the tool itself or is process dependent is not known at this time.

Both RFI S/Ns 2 and 3 were trimmed to length, and RFI S/N 3 was subjected to destructive testing under four-point beam bending. The dropoff from each spar was sectioned into physical properties coupons. Results of these analyses are: S/N 2 fiber volume: 52.8%, resin volume: 46.0%; S/N 3 fiber volume: 57.3%, resin volume: 41.2%.

RTM OF KNITTED/STITCHED Y SPAR

The last of the four G40-800 knitted/stitched graphite Y-spar preforms fabricated by Compositex Corporation was RTM processed. The resin system chosen for the preform's impregnation was Dow Tactix 123/H41.

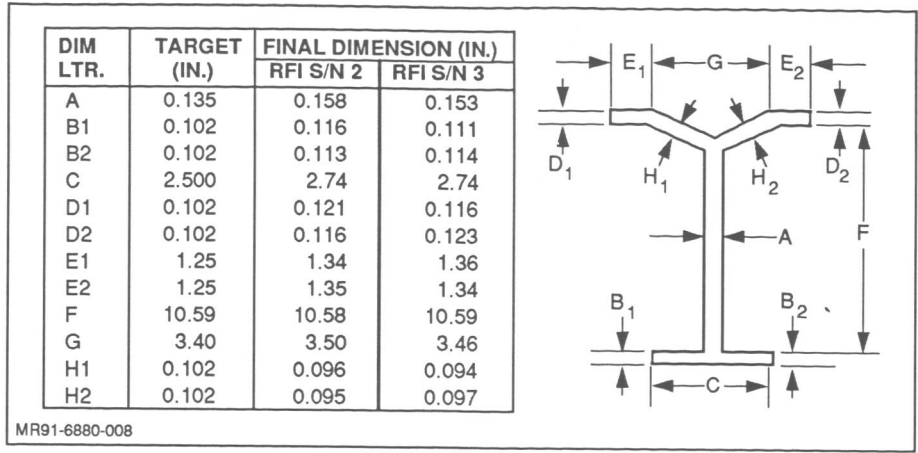

Figure 8 Comparison of RFI S/Ns 2 and 3 Target and Final Part Dimensions

Overall, this operation produced good results, yielding a part with only minimal resin richness along its periphery in localized areas. The completed Y spar is shown in figure 9. The only major anomalies exhibited in the part were localized dry areas in the angular segments of the Y flange. These resulted from a blown O-ring seal in the Y flange during processing. Results of the ultrasonic inspection of this spar confirmed that these areas were unsatisfactory. However, the remainder of the part was predominantly free of sonic indications.

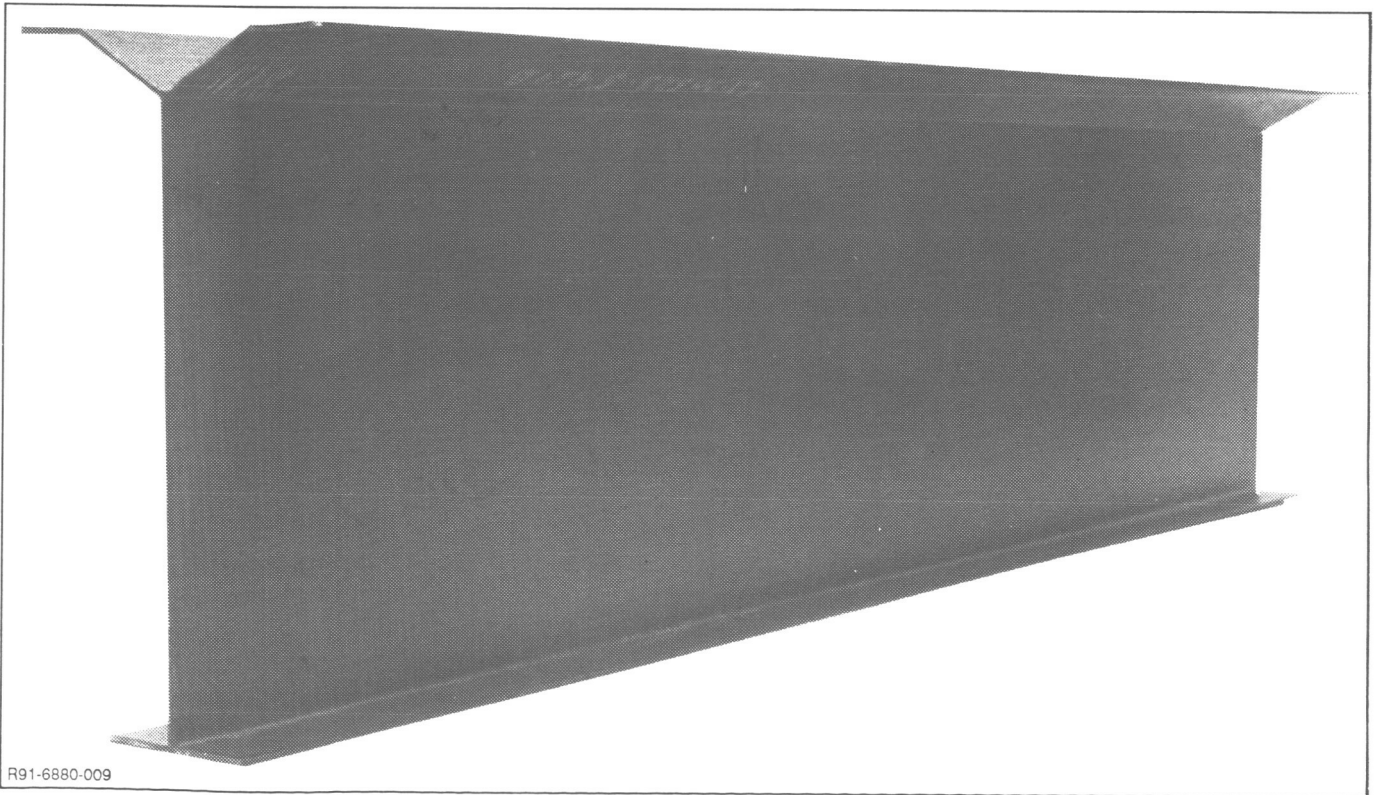
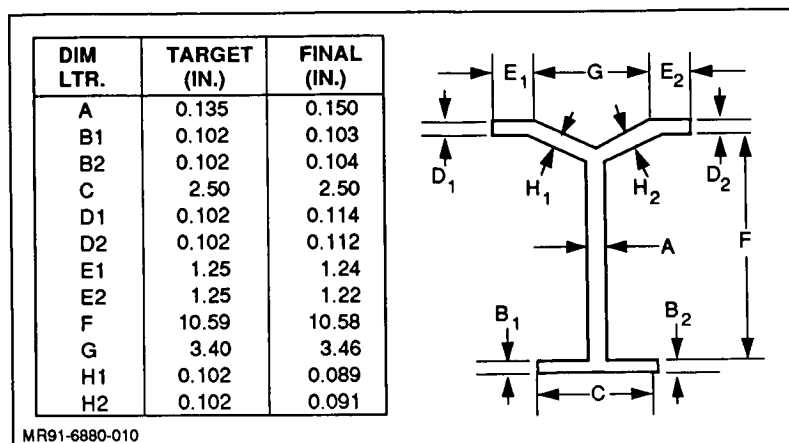

Figure 9 Completed Knitted/Stitched (RTM) Y Spar No. 1

A preliminary dimensional analysis of the RTM-processed Y spar provided the results shown in figure 10. Again, overall results are excellent. There are two potential causes for concern, however. The first is the somewhat-thin angular faces of the Y end, dimensions H1 and H2. This condition is undoubtedly due to the previously discussed seal failure.



MR91-6880-010

Figure 10 Knitted/Stitched G40-800/Dow TACTIX 123/H41Y Spar S/N 1 (RTM Processed) Target and Final Part Dimensions

The other concern is the inconsistency in the thickness of the web, dimension A. Although shown in figure 10 as only a 0.015-in. deviation from the target value (0.150 vs 0.135 in.), the difference is in fact the result of an increase in the web thickness toward the spar's center. The ends of the web measure 0.138 in. and 0.142 in. thick, whereas the center measures 0.170 in. It is not clear whether this condition was caused by a tooling problem [localized thickness (bulkiness) in the preform], or is somehow related to the seal failure experienced during resin injection. Physical property analysis yielded an average fiber volume of 52.5% and an average resin volume of 47.4%.

RFI OF ANGLE INTERLOCK WOVEN Y SPAR

The 0-/90-deg IM7(12K) carcasses were woven by TTI, Hatboro, PA, on a Jacquard loom. This fully automatic weaving system involves a series of punched cards to control the carcass's architecture based on engineering requirements. The ± 45 -deg ply material was then located on the outside faces of both the webs and the flanges of the completed carcasses by TTI. The ± 45 -deg plies were then semiautomatically stitched in place by Ketema Textile Products Div., Anaheim, CA, using Toray T900-1000A fiber. (The stitching operation was necessitated by the fact that weaving is currently limited to 0- and 90-deg orientations.) This completed the preforms, which were then shipped back to TTI for removal of a PVA serving from the yarns. This serving, required to maintain integrity of the yarns during the weaving operations, was boiled off in multiple steps in large tanks. After TTI's quality checks, the preforms were shipped to Grumman for inspection.

Unfortunately, during inspection of the first three preforms, it was discovered that the TTI woven carcasses were not correct. Dimensional checking revealed that they were oversized and too thick. Specifically, the web heights, targeted to be 9.7 in., were woven between 10.5 and 11.0 in. Additionally, both the webs and the flanges of the carcasses were thicker than originally called for. TTI's investigation of their processing records indicated that the IM7 spar carcasses (0-/90-deg), were woven at 22 ppi, not 11, as was called for by these structures' architecture.

The fourth carcass was woven by TTI with the proper number of ppi based on the specified architecture, resulting in a Y-spar preform conforming to the engineering requirements. The completed preform is shown in figure 11. After inspection, it was sent to Compositек Corporation for processing via RFI and Autocomp.

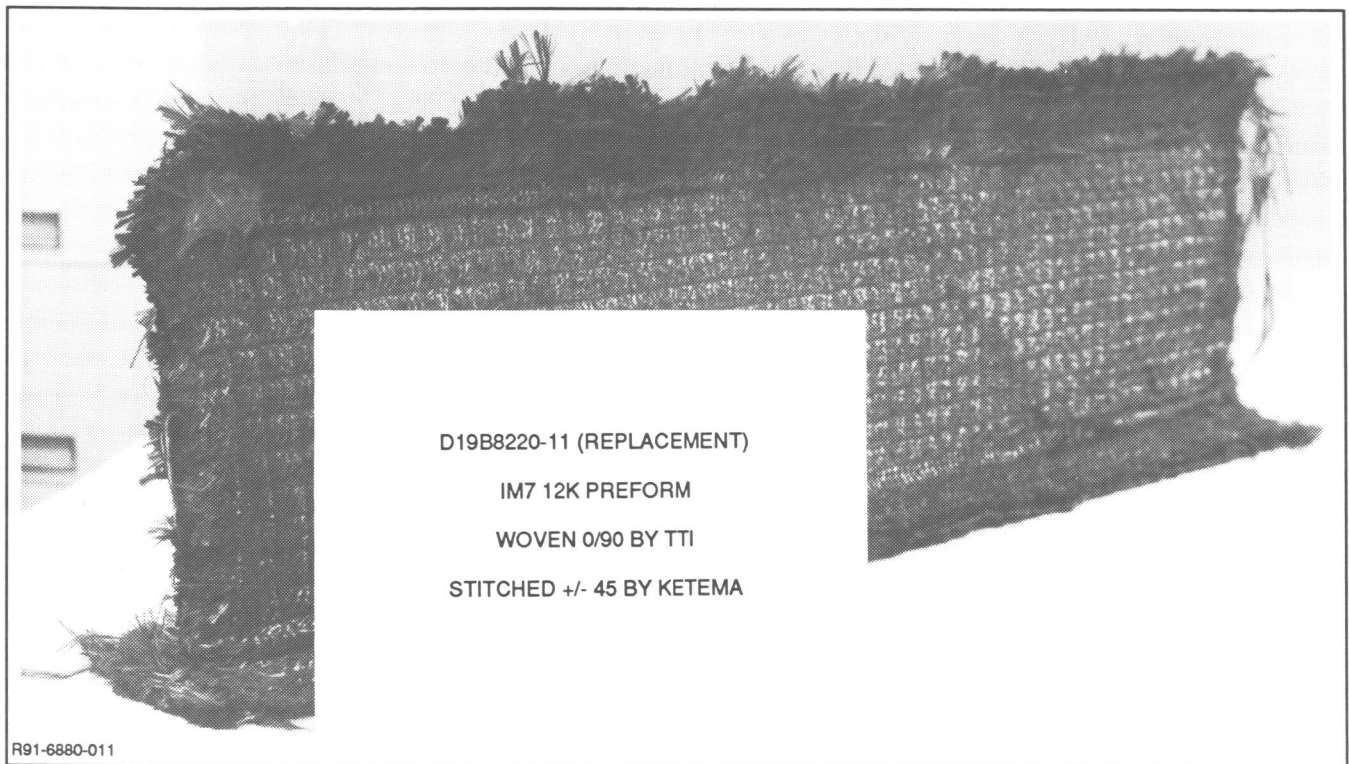
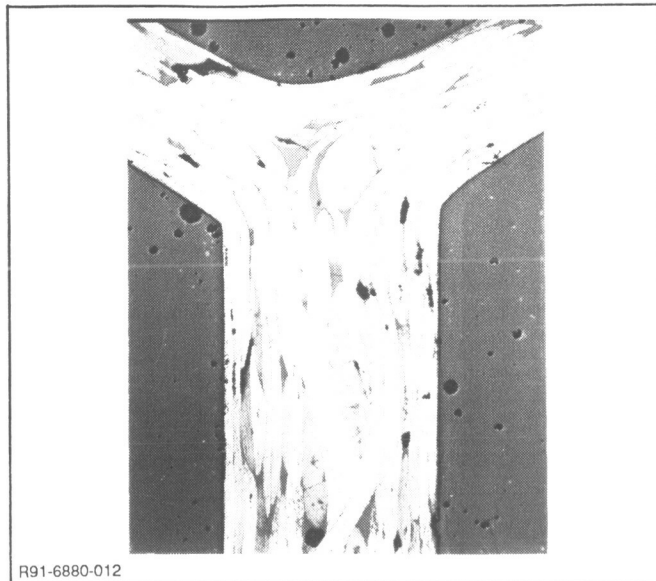

Figure 11 D19B8220-11 Replacement Preform Prior to Processing

The woven/stitched IM7 3-D preform Y spar was processed by Compositек using RFI and Hercules 3501-6 resin. NDI of the Y spar revealed significant porosity. It was decided to test the spar in four-point beam bending to assess the importance of porosity in its structural performance. Specimens were cut from each end of the spar to obtain photomicrographs of the web and flange cross-sections (see figure 12). The dimensional analysis of this replacement Y spar is presented in figure 13.



R91-6880-012

Figure 12 Photo Micrograph of IM7/3501-6 Y Spar (RFI)

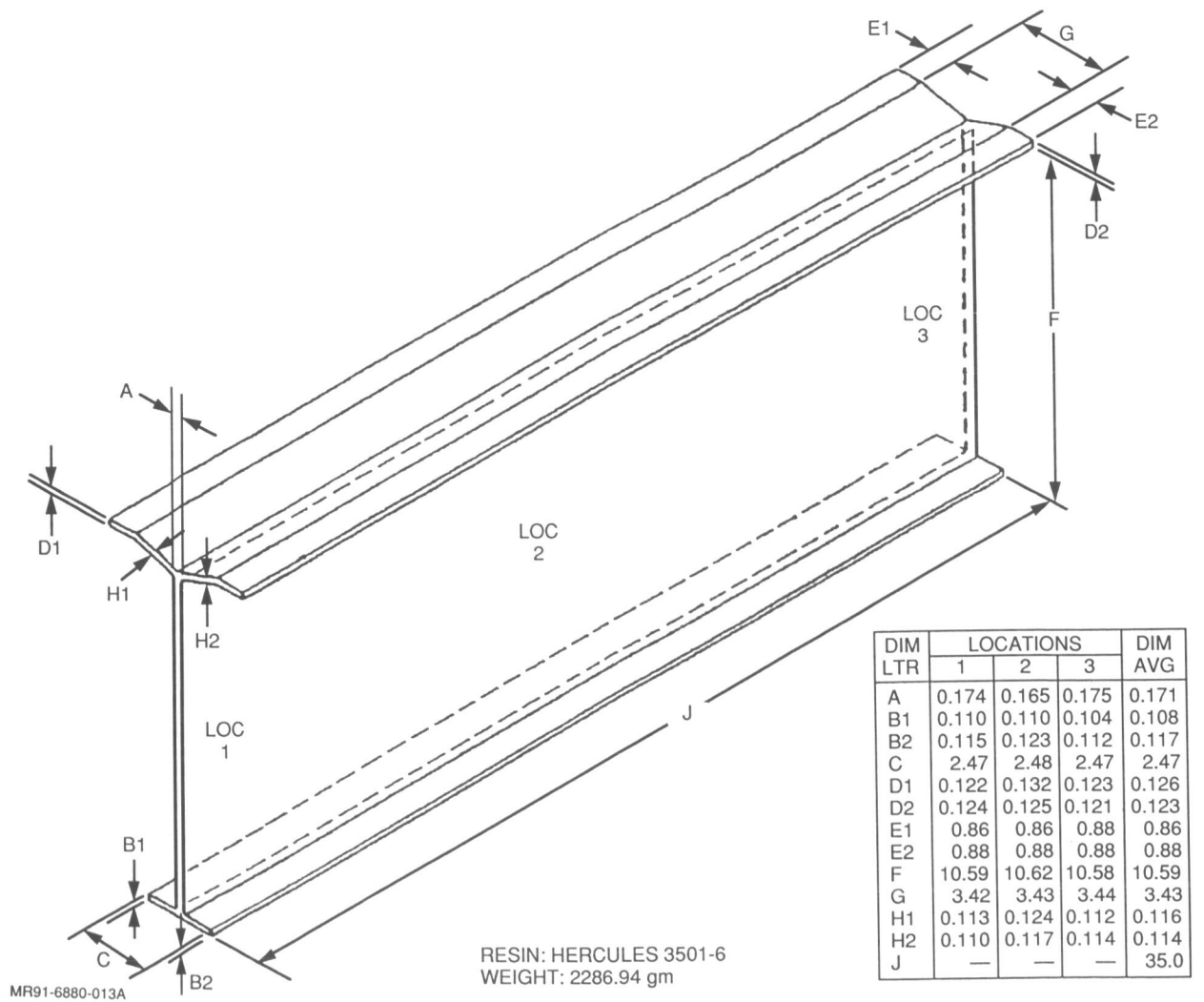

MR91-6880-013A

Figure 13 Dimensional Analysis of D19B8220-11 Y Spar (Replacement) RFI Processed

Resin content and fiber volume determinations for the RFI woven/stitched Y spar were:

	<u>WEB</u>	<u>FLANGES</u>
Percent fiber volume	56.1	53.2
Percent resin volume	41.1	45.0
Percent void volume	2.8	1.8

Y-SPAR TESTS

The Y-spar element was configured as a 35-in.-long by 10.8-in.-high beam. The beams have IM6/3501-6 graphite epoxy caps mechanically fastened to the top of the Y web. Load introduction was via aluminum attachment fittings sandwiched around the spar web and bolted in place. The specimen was loaded as a four-point bending beam by the fixture shown in figure 14. Two concentrated loads were applied 3.0 in. away from both sides of the midpoint of the 30.0-in. test span to provide a moment arm of 12 in. Strain measurements were obtained via 10 axial and 4 three-element rosettes located back to back along the center line of the beam (figure 15), except for the consolidated Y spar. The AS4/PEEK commingled Y spar had 8 three-element rosettes and eight axial gages (figure 16). Concurrent with load application midspan deflection was recorded with a dial gage. The spars were loaded to 50% limit load, unloaded, loaded to limit load, unloaded, loaded to ultimate load, held, and then loaded to failure.

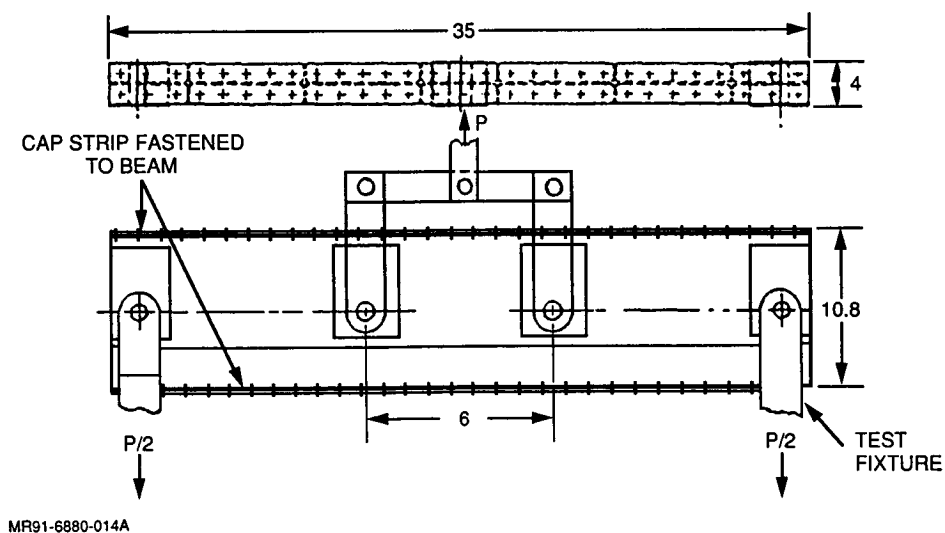
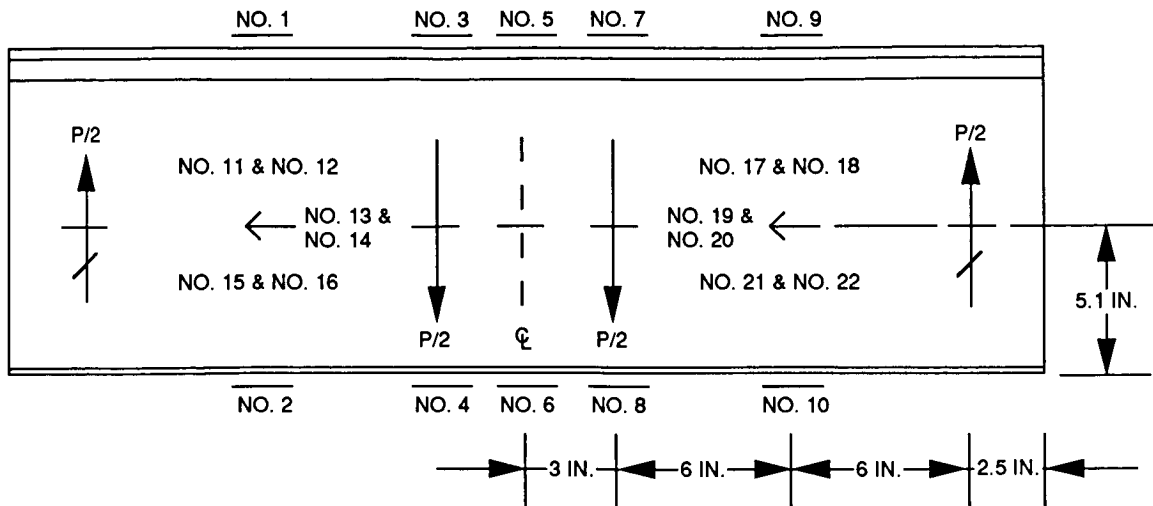
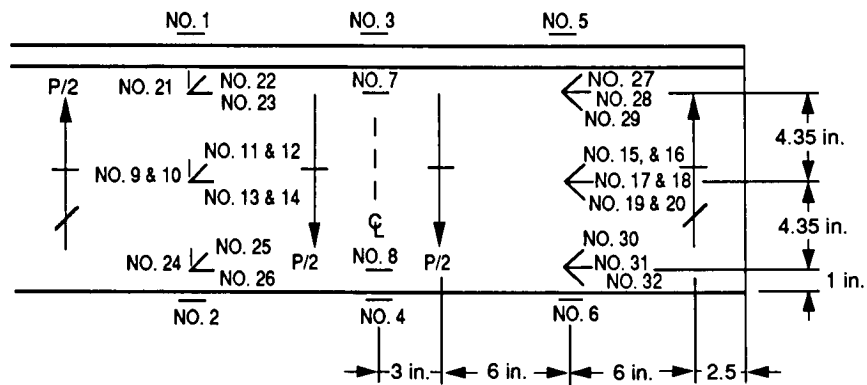

Figure 14 Y-Spar 4-Point Bending Test Setup



MR91-6880-015

Figure 15 Strain Gage Locations (Except for Woven AS4/PEEK Commingled Y Spar)



MR91-6880-016

Figure 16 Strain Gage Locations for Woven AS4/PEEK Commingled Y Spar

TEST RESULTS

In general, the measured strains agreed well with the predictions. This is significant when one considers that the stiffness properties were derived from unidirectional tape properties with corrections made for fiber volume and the woven nature of the AS4 preform. Spar bending strains at failure were close to or exceeded $\pm 6000 \mu\text{in./in.}$ in all cases. Whereas only the G40-800/Tactix 123 test specimen failed due to the load in the spar itself, this failure compared well with the average predicted value for an IM6/3501-6 unidirectional tape prepreg laminate, autoclave cured. The structural aspects of each test spar are briefly discussed below.

Woven AS4/PEEK Commingled

Although this spar had problems during the preform fabrication, and the final product was oversize in height and thickness, its performance during the test was predictable. Figures 17 to 19 show

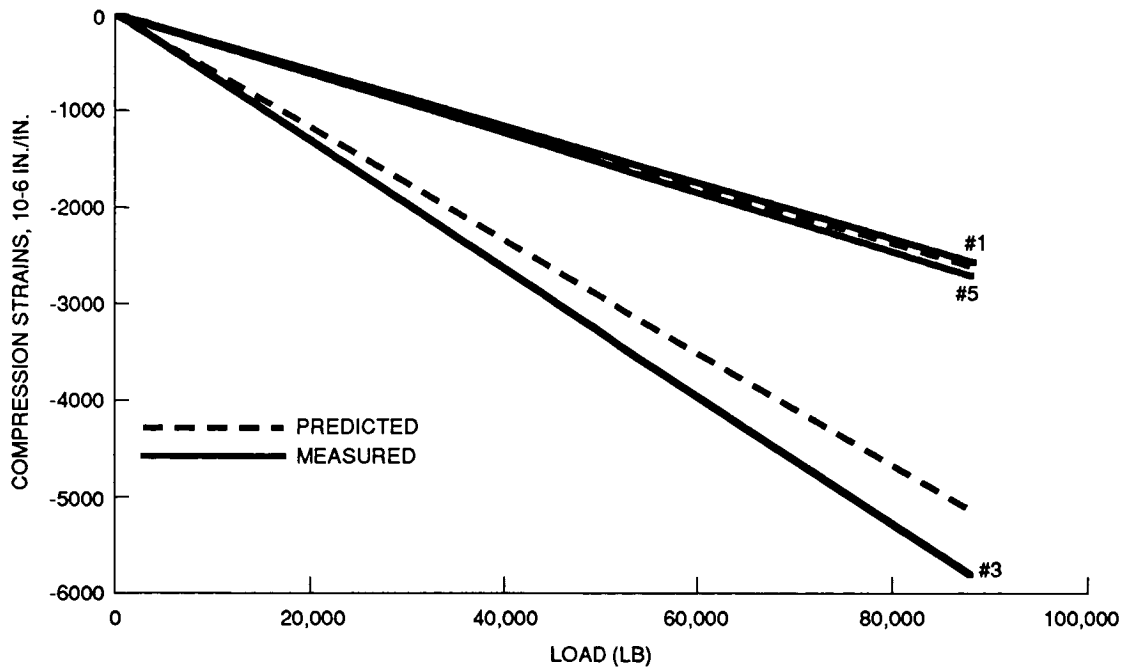

MR91-6880-017

Figure 17 Compression Strain vs Applied Load for Woven AS4/PEEK Commingled Y Spar

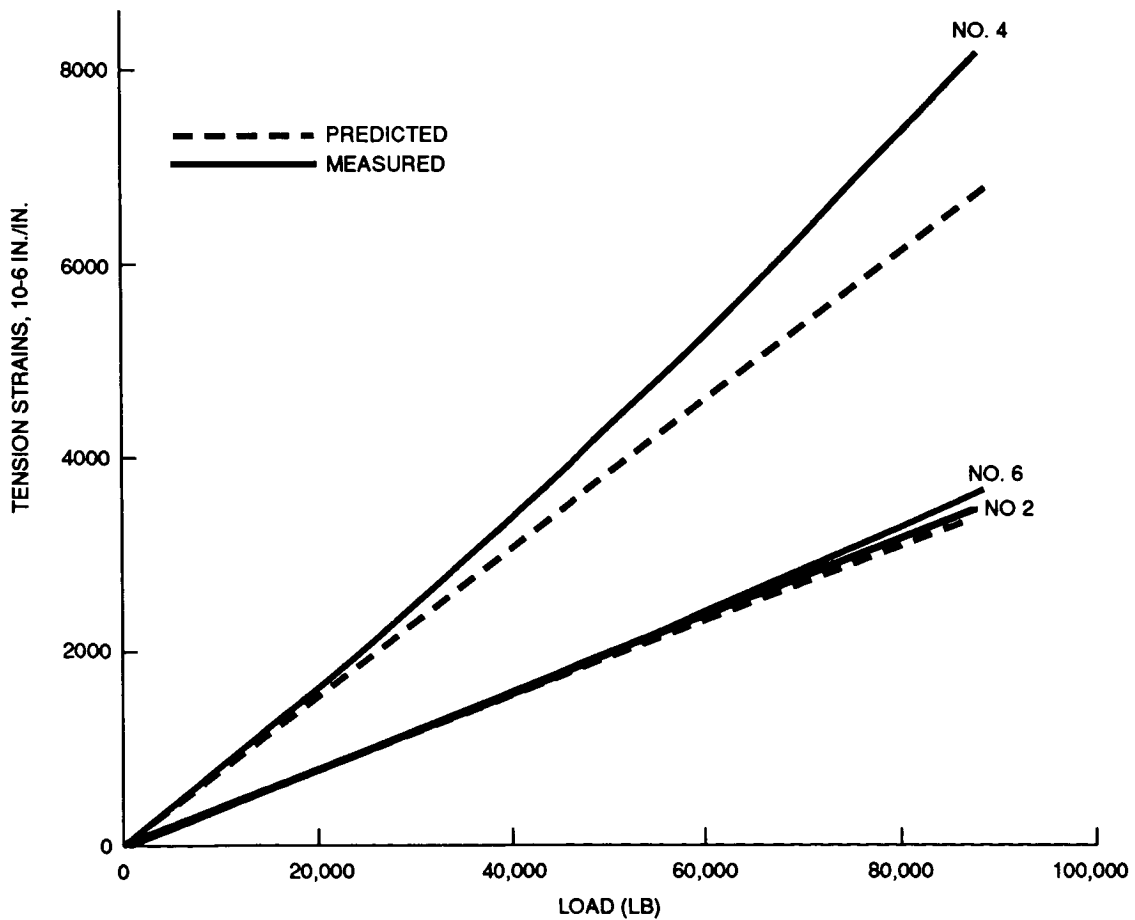

MR91-6880-018

Figure 18 Tension Strain vs Applied Load for Woven AS4/PEEK Commingled Y Spar

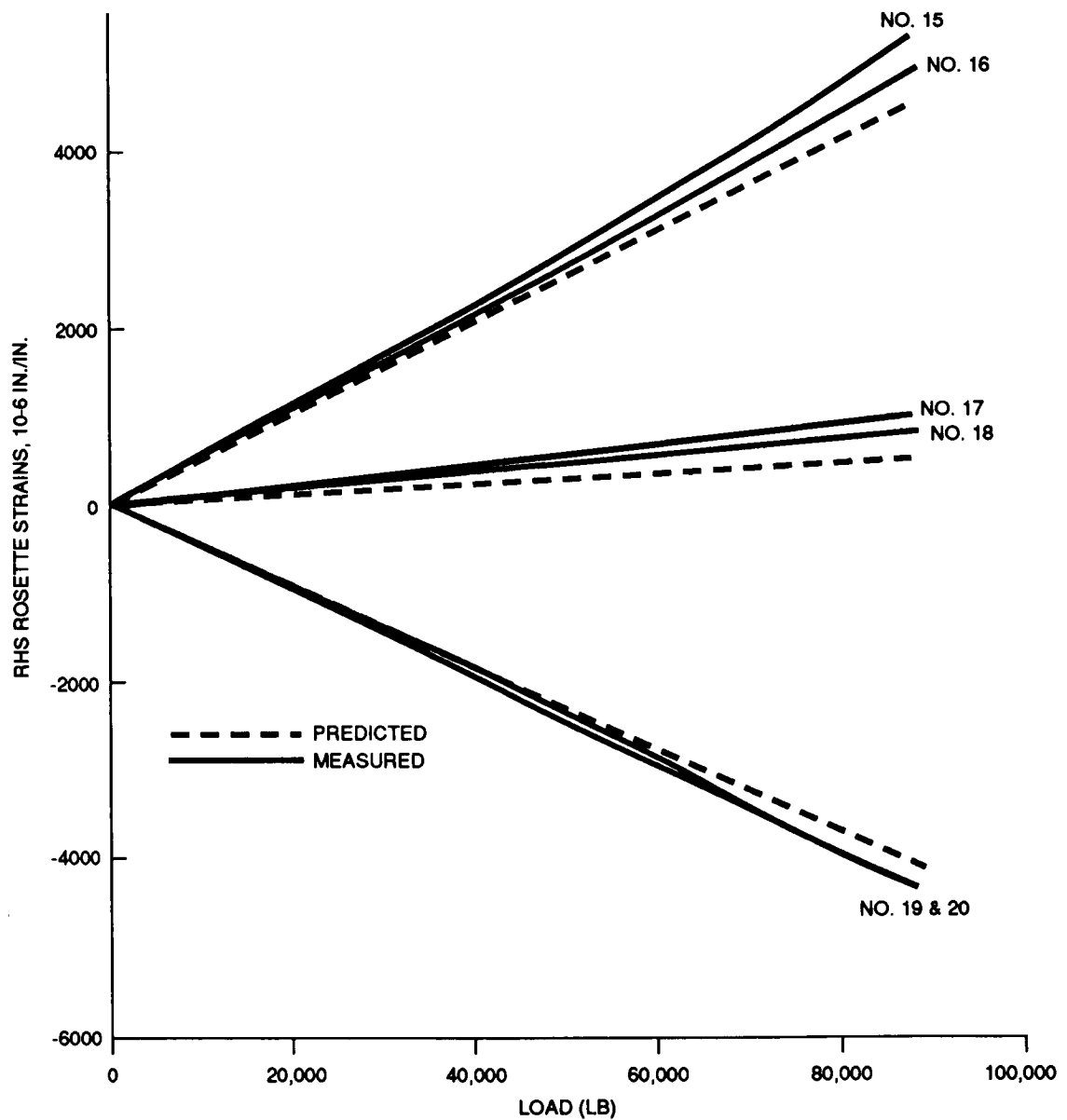

MR91-6880-019

Figure 19 Strain vs Applied Load for Woven AS4/PEEK Commingled Y Spar

measured and predicted strain vs applied load. Predictions are based on a 11.8/41/47.2% (0-/±45-/90-deg) laminate obtained from the results of coupon testing. Due to the increased thickness, web buckling and a web shear failure were precluded. Failure at an applied load of 89,000 lb occurred because the tensile load in the cap exceeded the open-hole strength. The bending strains at failure were +8270 $\mu\text{in./in.}$ and -5940 $\mu\text{in./in.}$, showing that this manufacturing approach met the program goal of ± 6000 $\mu\text{in./in.}$ in bending. See figure 16 for gage locations.

Knitted/Stitched G40-800/Tactix 123 (RTM)

The strain response of this spar is plotted in figures 20 to 22. The maximum tension strain was 9577 $\mu\text{in./in.}$ and the maximum compression strain was -5716 $\mu\text{in./in.}$ Whereas the bending strains are in good agreement with the predictions, the shear strain is higher than expected. This is probably because of a lower effectiveness of the surface plies as a result of surface dryness noted in the spar. Using the measured shear strain and the analytical shear flow implies an effective 0.120-in.-thick, 10/56/34% laminate as opposed to the 0.138-in.-thick, 9/62/29% laminate expected. This revised laminate has an E_t of $0.704 \times 10^6 \text{ lb/in.}$ and a G_t of $0.440 \times 10^6 \text{ lb/in.}$; whereas the laminate used for pre-test analysis had an E_t of $0.778 \times 10^6 \text{ lb/in.}$ and a G_t of $0.548 \times 10^6 \text{ lb/in.}$ As a result, the net change in bending stiffness is small, while the change in shear strain is high. Web buckling occurred at an applied load of $\sim 60,000 \text{ lb}$ or an average flat web shear flow of 2840 lb/in. Predicted buckling varied from 2070 lb/in. for simply-supported edge conditions, to 3190 lb/in. for clamped edges. In both cases, a reduction in stiffness was taken for the surface plies only and the actual thickness was used. At the failure load of $65,300 \text{ lb}$, the calculated maximum shear stress in the web was $31,200 \text{ lb per sq in.}$ on the effective thickness and normalized to 62%

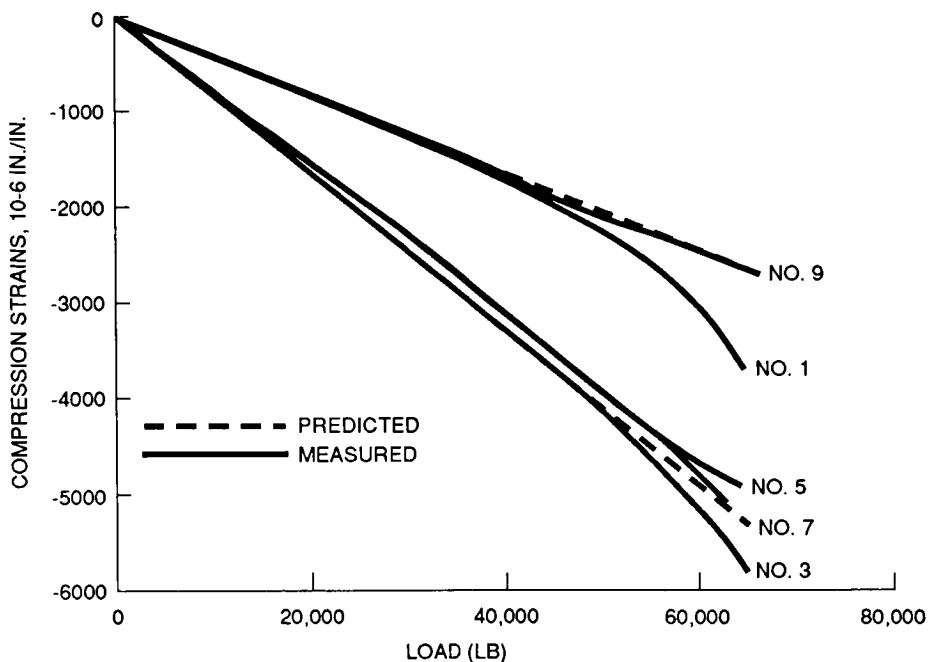

MR91-6880-020

Figure 20 Compression Strain vs Applied Load for G40-800/Tactix 123 (RTM) Y Spar

fiber volume. Compared to a design allowable for IM6/3501-6 prepreg tape of 27,000 lb per sq in. and an average strength of 33,750 lb per sq in., the RTM process is considered structurally viable once provisions are made to ensure that all the fibers are rendered effective.

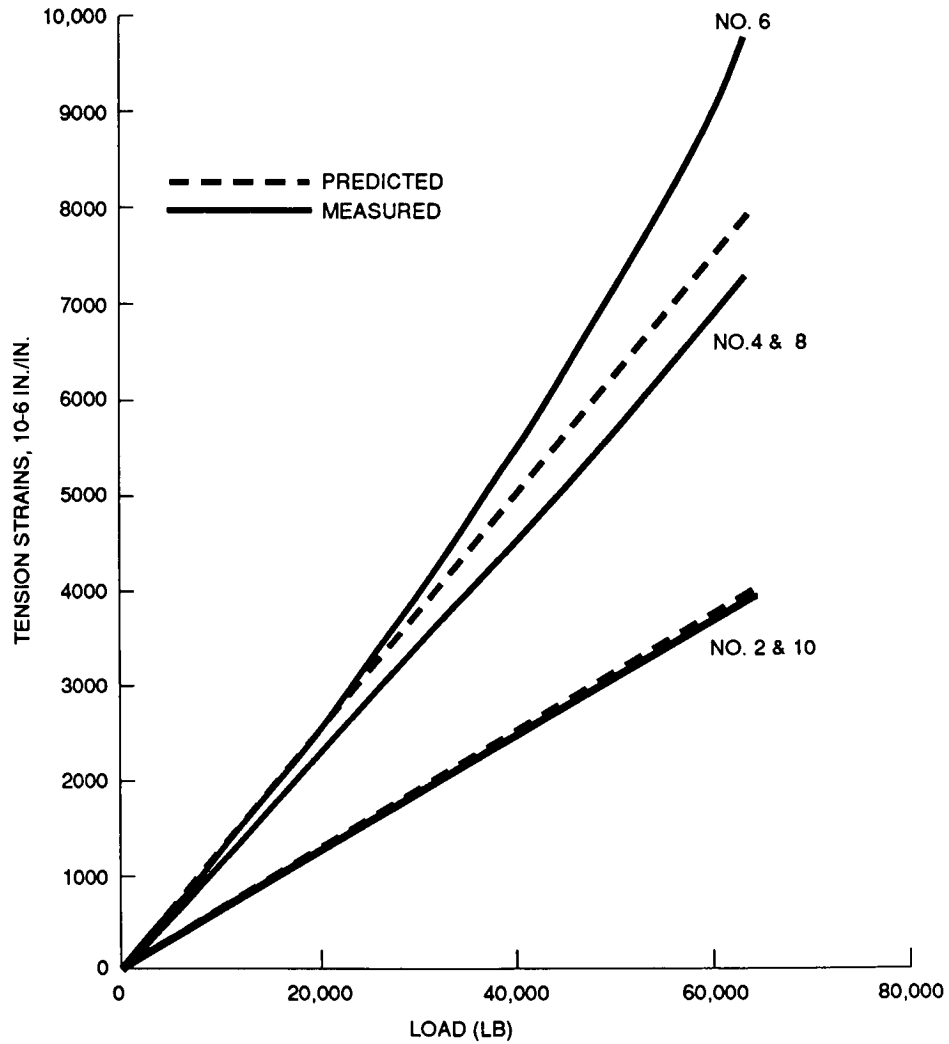

MR91-6880-021

Figure 21 Tension Strain vs Applied Load for G40-800/Tactix 123 (RTM) Y Spar

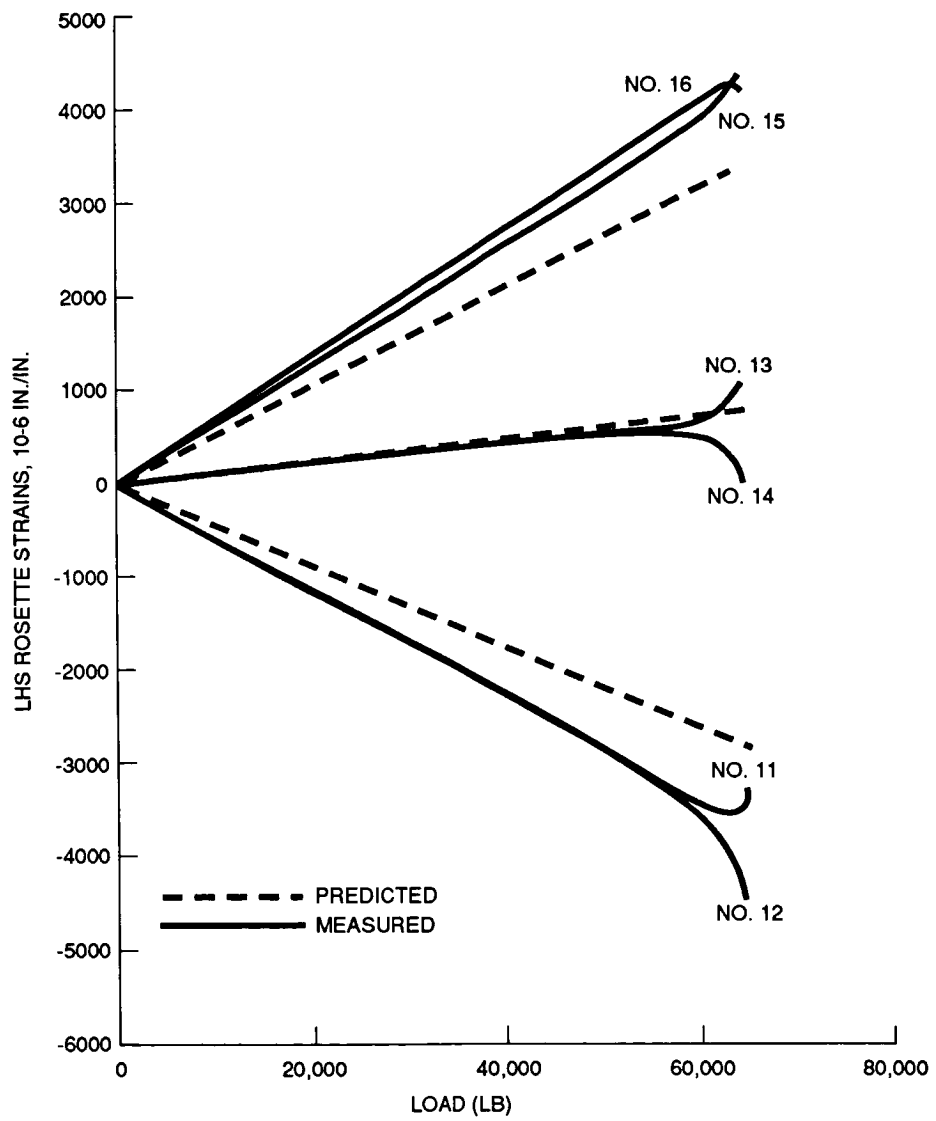

MR91-6880-022

Figure 22 Web Strain vs Applied Load for G40-800/Tactix 123 (RTM) Y Spar

Knitted/Stitched G40-800/3501-6 (RFI)

This spar, shown in figure 23, performed very well as seen from the strain plots in figures 24 and 25. The maximum tension strain was 11,550 $\mu\text{in./in.}$ and the maximum compression strain was -6128 $\mu\text{in./in.}$ Buckling of the web occurred at ~70,000 lb of applied load, or an average shear flow of 3320 lb/in. Analytical buckling predictions were 3530 lb/in. for simply-supported edges and 4780 lb/in. for clamped edges. Examination of the failed beam revealed that the stacking sequence of the web was not symmetric and hence, the premature buckling. The test beam failed at an applied load of 76,000 lb, due to local bending of the compression cap. At this load, the maximum calculated web shear stress was 36,540 lb per sq in. on the effective thickness and normalized to 62% fiber volume. Thus, the RFI process also proved to be very structurally acceptable.

Woven IM7/3501-6 (RFI)

The IM7 woven Y spar impregnated with 3501-6 resin by RFI was tested as a beam in four-point bending. The beam-bending specimen was instrumented with 22 strain gages. Mid-span deflection was measured with a dial gage. After installation into the test machine, the beam was loaded to 7000 lb (50% limit load) in 1000-lb increments, and then unloaded. Measured strains were compared with predictions, and checked for any anomalies. The beam was then loaded to limit load and unloaded. The measured strains were generally lower than the predictions, but repeatable and linear. The beam was loaded to ultimate (21,000 lb), held, and then loaded to failure. Failure occurred at a load of 69,200 lb and was due to the tensile stress in the cap, as shown in figure 26. The maximum tension strain was 8470 $\mu\text{in./in.}$ and the maximum compression strain was -4770 $\mu\text{in./in.}$ Maximum mid-span deflection was 0.258 in. Figures 27 through 30 are plots of predicted and measured strain vs test load for the compression gages, the tension gages, and the two pairs of rosettes. The predictions were made using a slightly modified laminate that accounted for the measured fiber volume (56.1%) and thickness of the web.

The failure was the result of combined bolt load and passing tension in the IM6/3501-6 tension cap laminate ~12 in. from the end of the spar. Based on strain gage no. 8, the strain at failure was 6600 $\mu\text{in./in.}$ The predicted average tensile failure strain determined from HOLES program was 7070 ± 1410 $\mu\text{in./in.}$ Therefore, actual and predicted failure agreed within the scatter of the test data.

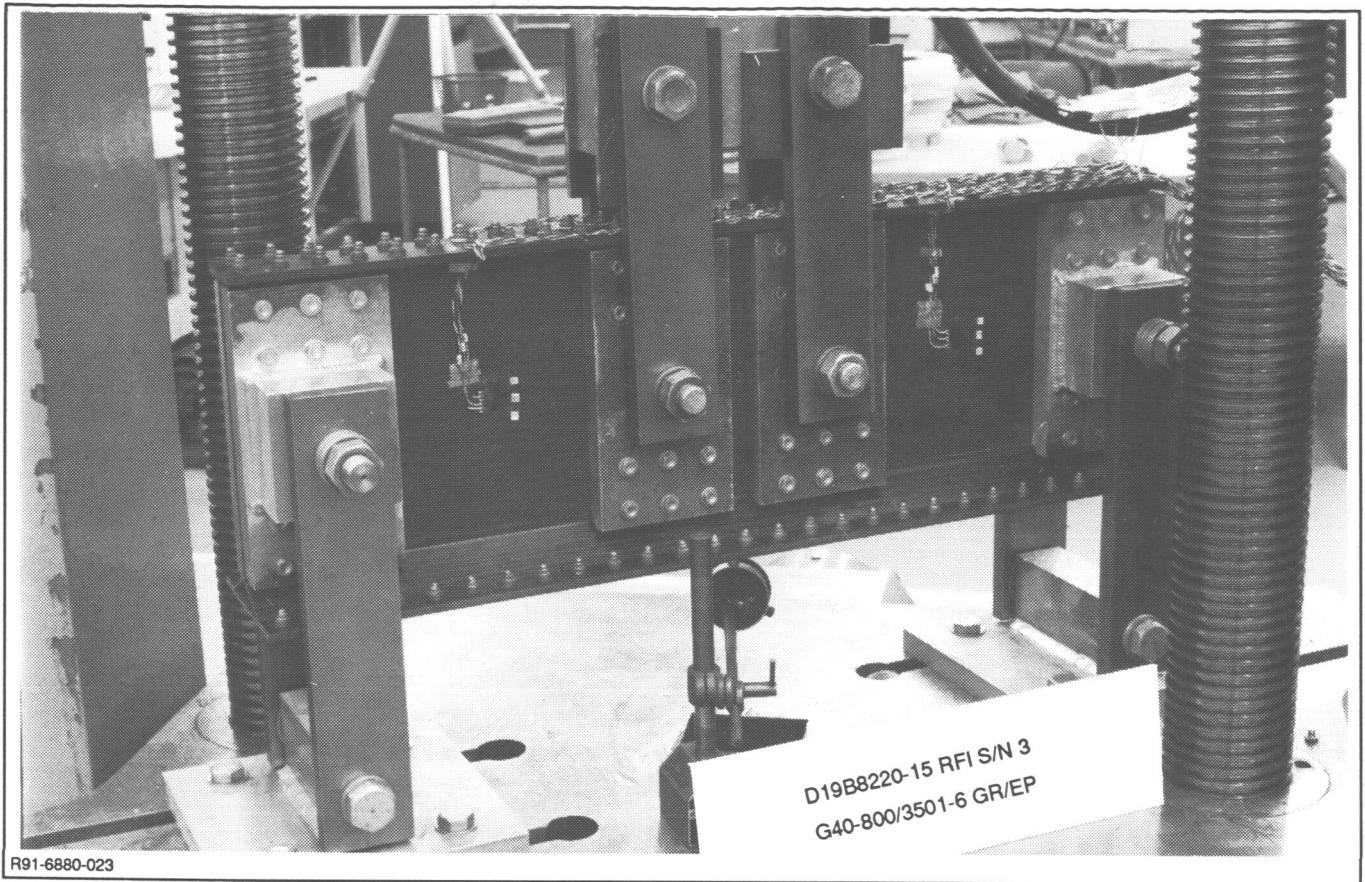
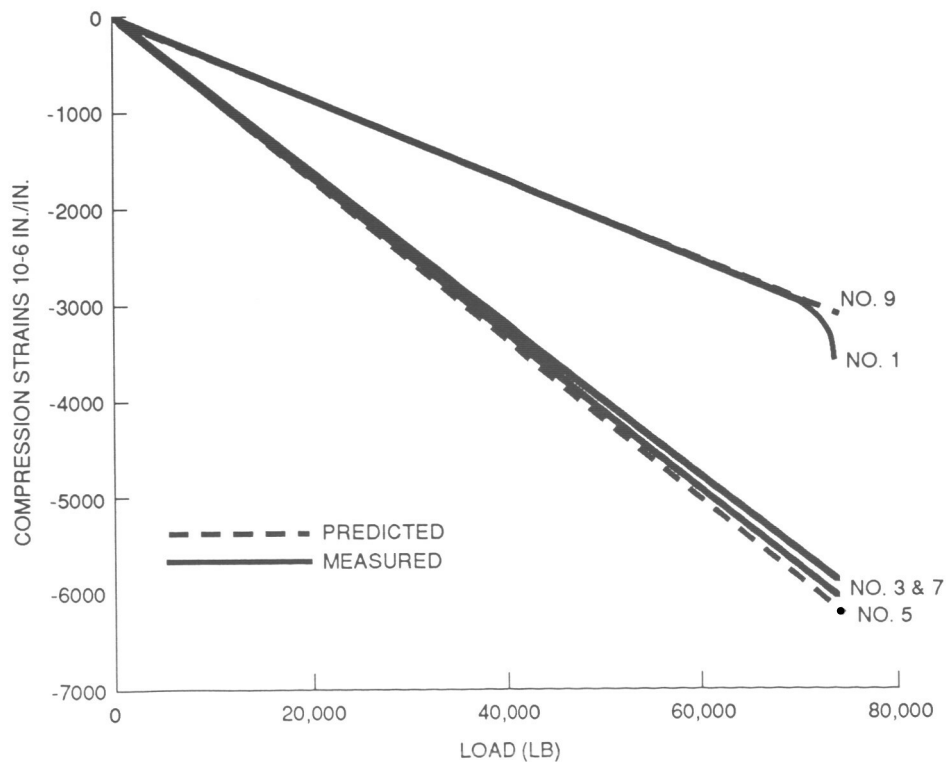
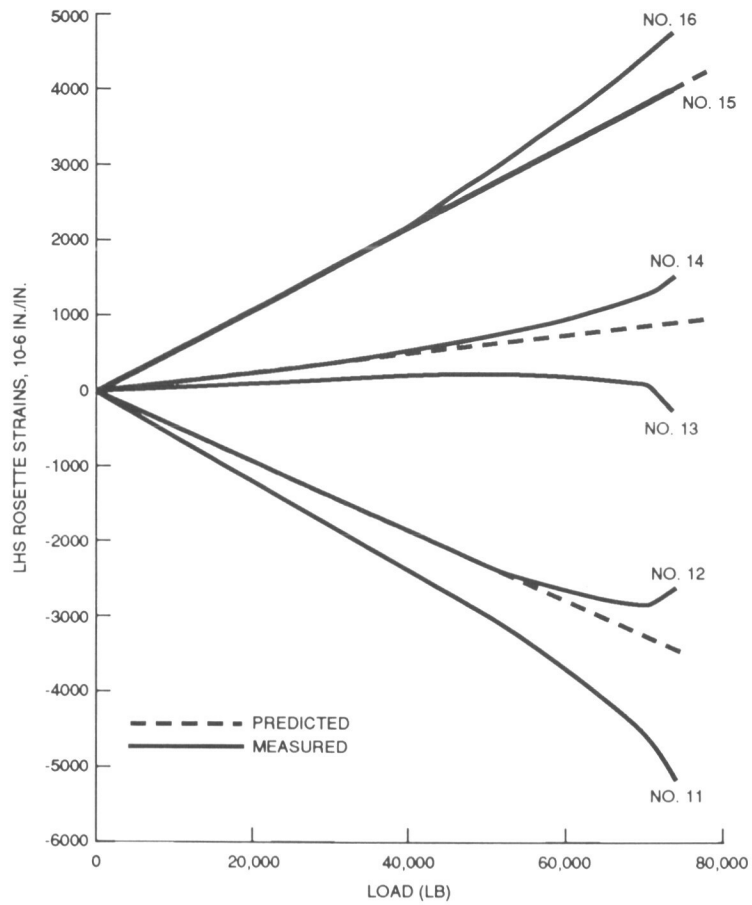

Figure 23 Test Setup for G40-800/3501-6 (RFI) Y Spar



MR91-6880-024

Figure 24 Compression Strain vs Applied Load for Knitted/Stitched G40-800/3501-6 (RFI) Y Spar



MR91-6880-025

Figure 25 Web Strain vs Applied Load for Knitted/Stitched G40-800/3501-6 (RFI) Y Spar

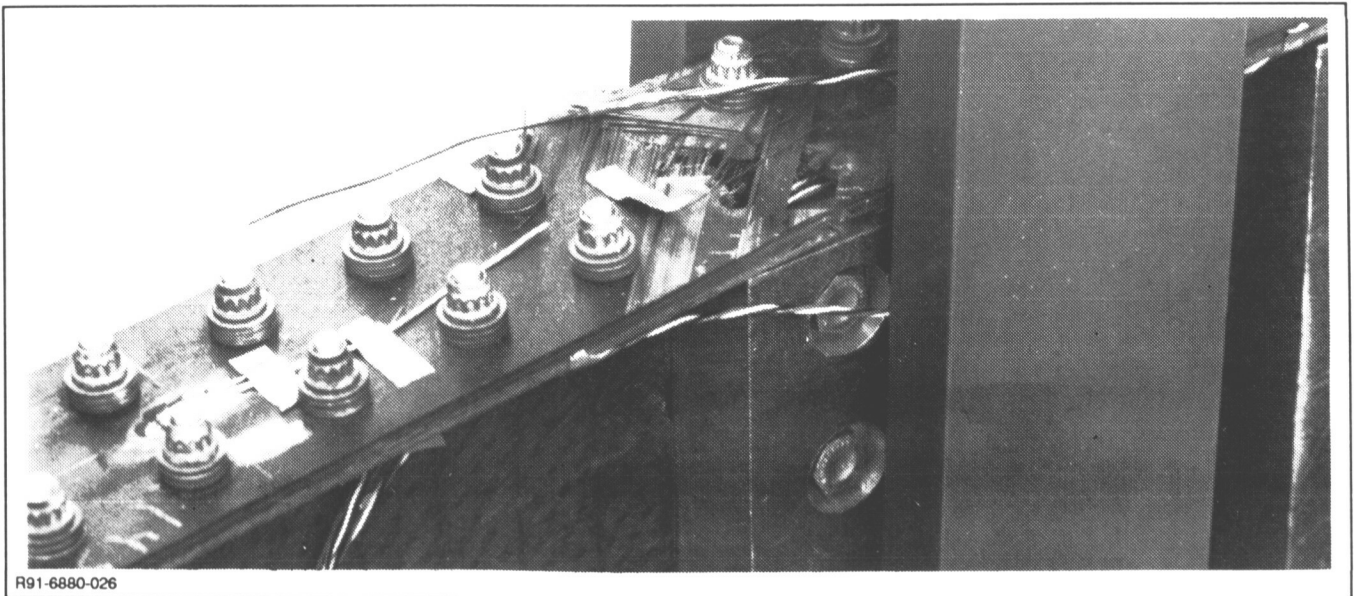

R91-6880-026

Figure 26 Woven IM7/3501-6 (RFI) Y Spar Showing Cap (IM6/3501-6 Gr/Ep Tape) Tensile Failure

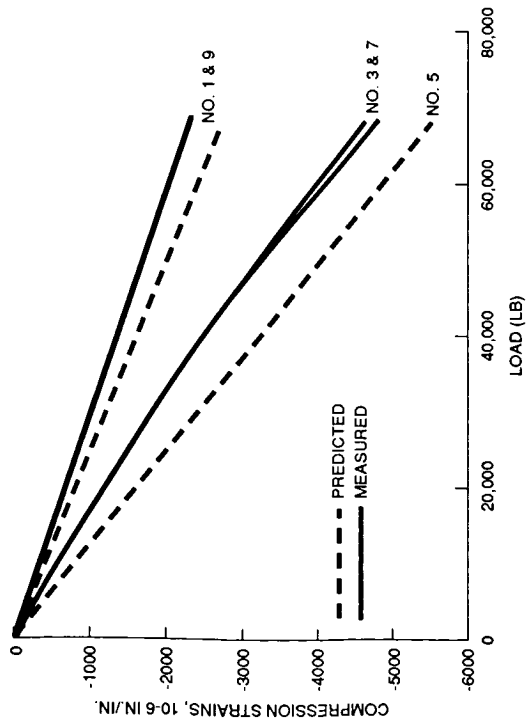

Figure 27 Compression Strain vs Applied Load for Woven IM7/3501-6 (RFI) Y Spar

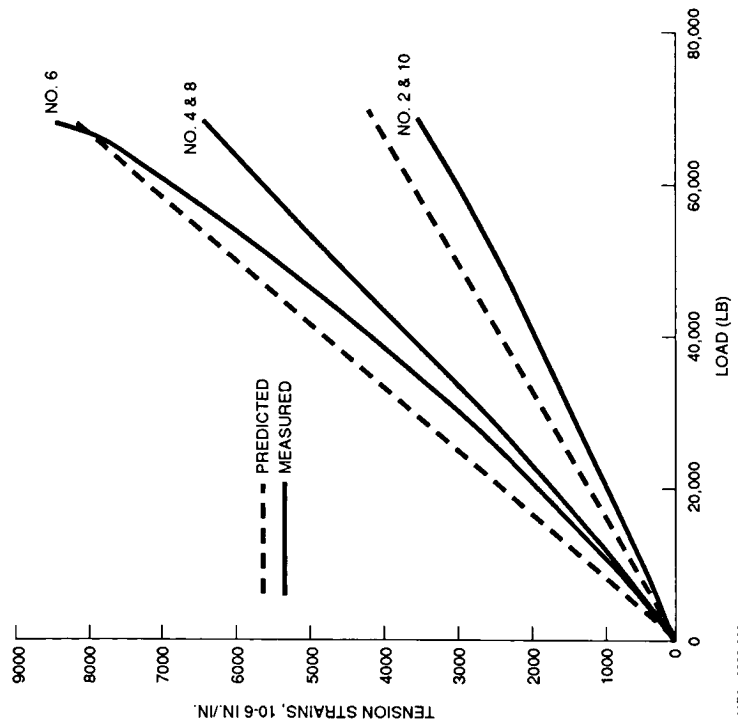

Figure 28 Tension Strain vs Applied Load for Woven IM7/3501-6 (RFI) Y Spar

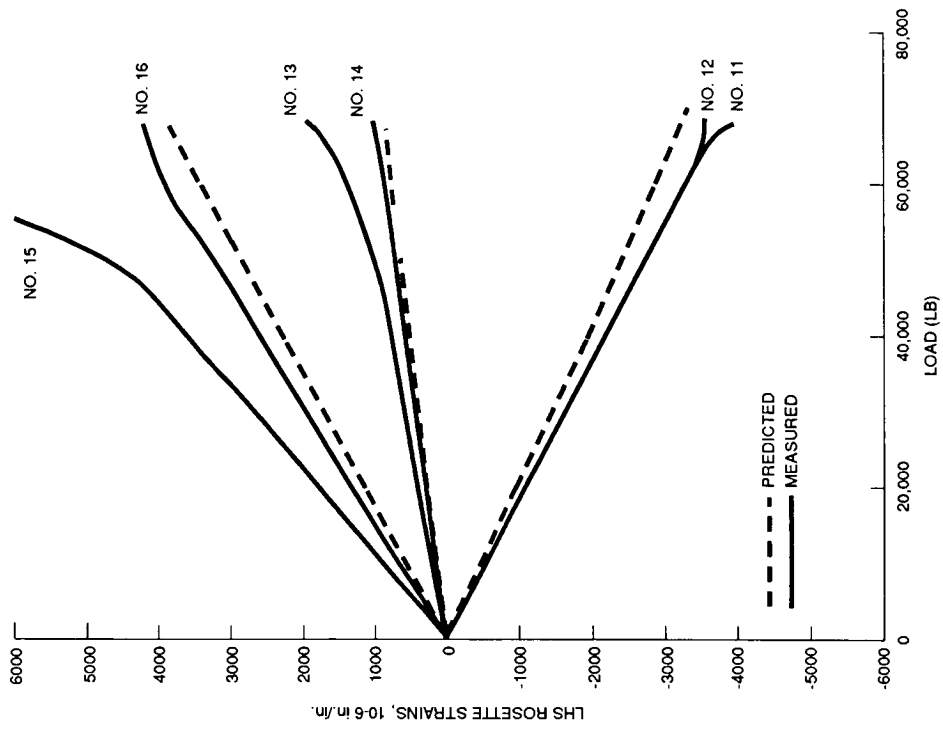
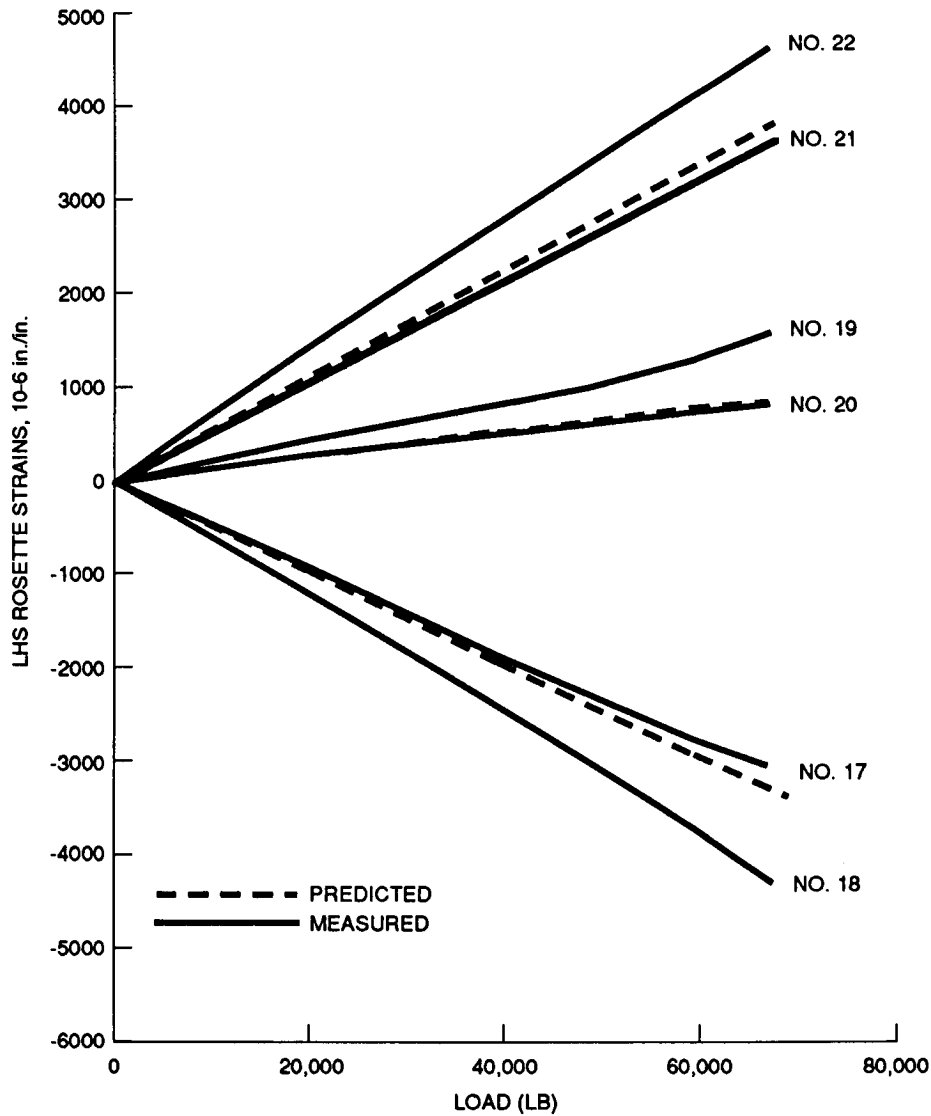

Figure 29 Strain vs Applied Load for Woven IM7/3501-6 (RFI) Y Spar (LHS Rosette)



MR91-6880-030

Figure 30 Strain vs Applied Load for Woven IM7/3501-6 (RFI) Y Spar (RHS Rosette)

STRUCTURAL EFFICIENCY

The various material form/processing combination Y spars were rated for their structural efficiency. As shown in figure 31, the knitted/stitched G40-800/3501-6 RFI Y spar is superior to all the others in terms of failure load per spar weight. The worst performer is the woven AS4/PEEK commingled Y spar, which was manufactured oversize. The knitted/stitched RFI spar also exhibited the highest ratio of web buckling to web area (figure 32), and the highest cap compression strain per unit weight, as shown in figure 33.

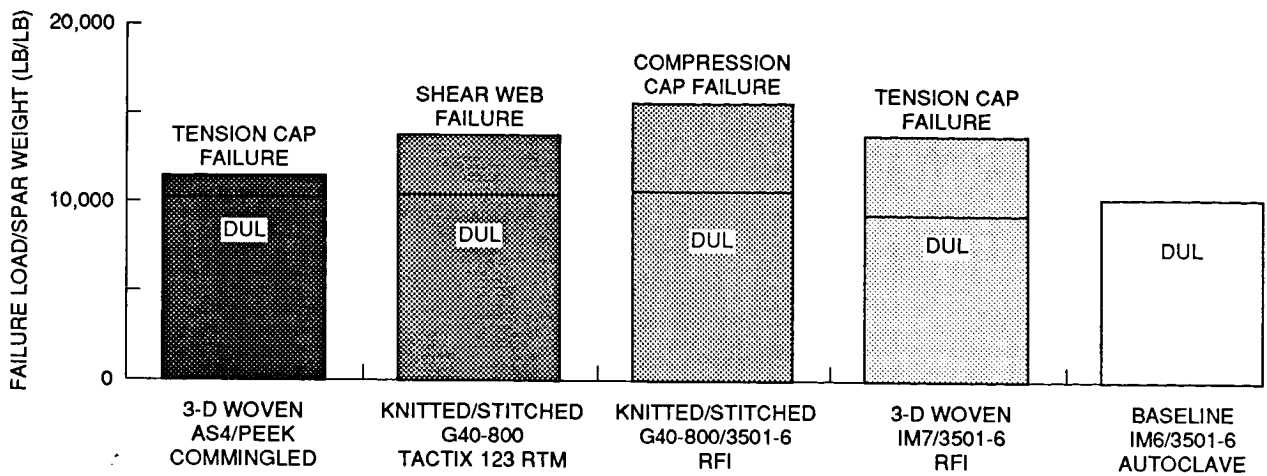

MR91-6880-031

Figure 31 Y Spar Failure Load per Unit Weight

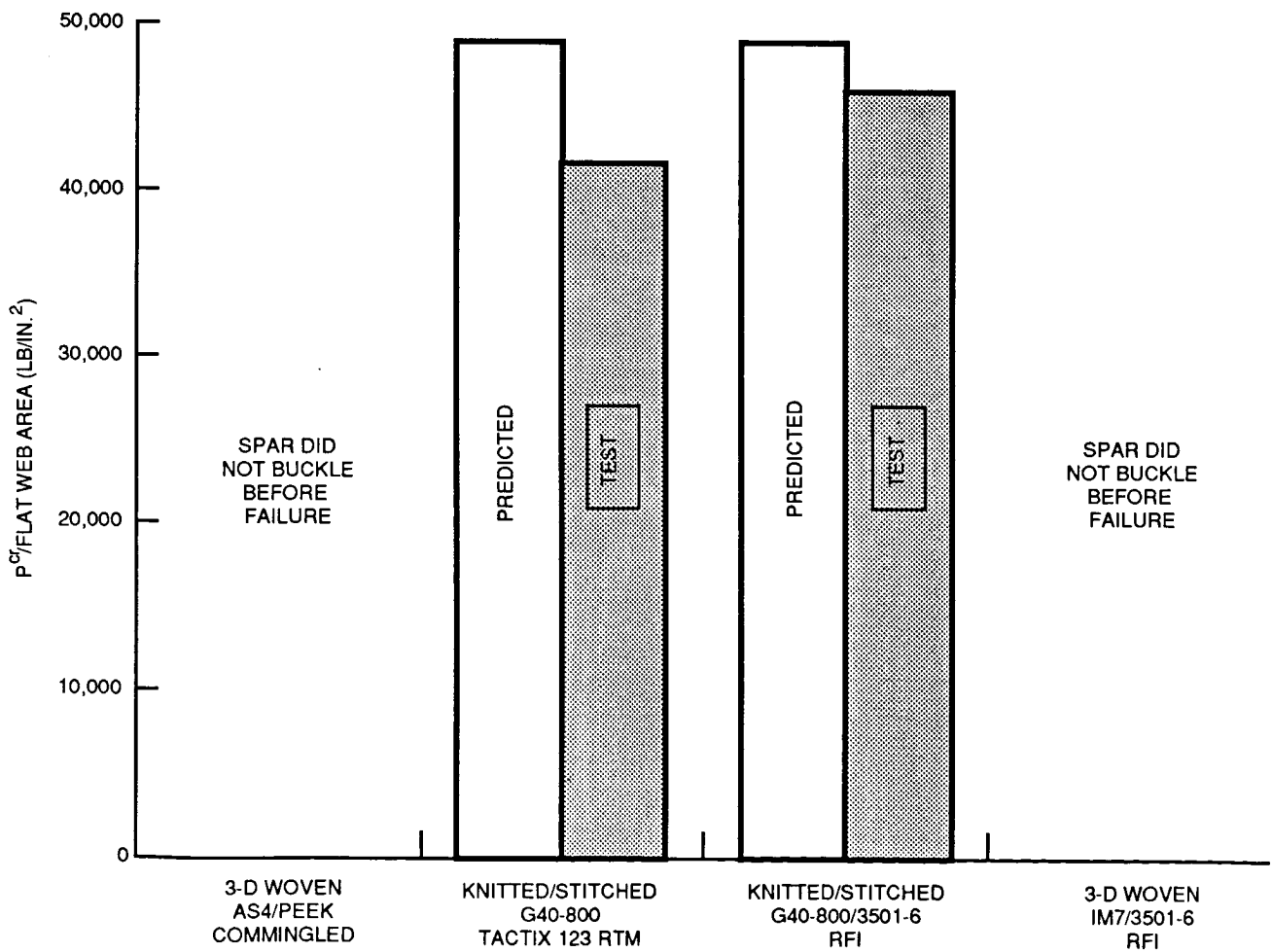

MR91-6880-32A

Figure 32 Y Spar Web Buckling

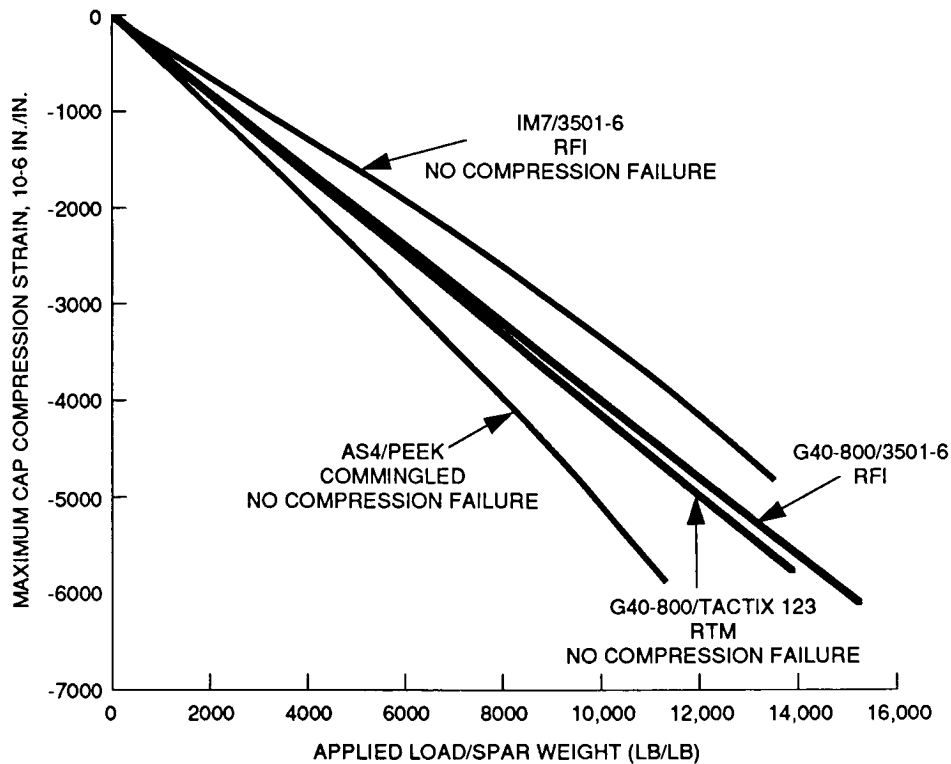

MR91-6880-033

Figure 33 Compression Strain vs Applied Load

PROJECTED COSTS

Manufacturing costs to produce the various Y spars were estimated for each of the four material form/processing combinations. These approaches are:

- Woven/stitched AS4/commingled PEEK preform thermoformed (consolidated) via autoclave/vacuum bag procedures
- Knitted/stitched G40-800 preform impregnated with Dow Tactix 123/H41 resin system via RFI, then autoclave processed
- Woven/stitched IM7 preform impregnated with Hercules 3501-6 resin system via RFI, then autoclave processed
- Knitted/stitched G40-800 preform impregnated with Hercules 3501-6 resin system via RFI, then autoclave processed.

Comparative manufacturing costs were based on actual costs for tooling (non-recurring costs), and estimates for labor and materials (recurring costs). These cost comparisons were developed for the fabrication of one Y spar of each type, based on a production run of 100 units.

Tooling Costs

Tooling for each of the three processes was designed and fabricated by outside subcontractors, each of whom specializes in the particular materials and processes involved in the tools. Actual tool fabrication costs are presented below, for each of the three tools:

- Aluminum RTM tool for D19B8220-11 Y spar: \$18,932.00
- Monolithic Graphite tool for D19B8220-13 Y spar: \$10,869.00
- Aluminum RFI/autoclave tool for D19B8220-15 Y spar: \$20,000.00.

To generate the prorated hours to reflect the design and fabrication cost of the 100-unit production run scenario, each of the above dollar figures was converted to an equivalent number of hours by dividing by a labor rate of \$100.00/hr. These prorated person-hour requirements are presented in Table I, along with the recurring labor hours for each of the three processes.

TABLE I. – QUANTITATIVE COMPARISON OF PERSON HOURS REQUIRED TO FABRICATE Y SPAR UNDER THREE MANUFACTURING APPROACHES

MANUFACTURING ACTIVITY	CANDIDATE MANUFACTURING PROCESSES			REMARKS
	RTM HR	AUTOCLAVE CONSOLIDATE HR	RFI/AUTOCLAVE HR	
TOOL DESIGN & FABRICATION	1.89	1.09	2.00	TOOL DESIGN/FABRICATION HR ARE PRORATED FOR 100 UNITS
PREFORM FABRICATION:				
• WEAVING 0-/90-DEG CARCASS	68.85	68.86	N/A	BASED ON TOTAL COST; 6 FOR \$41,310.00 BASED ON COST OF \$1758.22 EACH
• STITCHING ±45-DEG PLYS	17.58	17.58	N/A	
RTM FABRICATION:	34.80	N/A	N/A	BASED ON COST OF \$3480.00
• TRIM TO FIT TOOL; LOAD IN TOOL; MIX, METER, INJECT RESIN; CURE PART; REMOVE PART				
AUTOCLAVE CONSOLIDATION:	N/A	38.00	N/A	BASED ON ACTUAL HOURS EXPENDED AT GRUMMAN
• TRIM TO FIT TOOL; LOAD IN TOOL; APPLY ALL BREATHER & BAGGING MATERIALS; AUTOCLAVE CONSOLIDATE PART; REMOVE PART; TRIM TO FINISH DIMENSIONS				
RFI/AUTOCLAVE PROCESSING:	N/A	N/A	100.00	BASED ON COST OF \$10,000.00, WHICH INCLUDES THE COST OF THE KNITTED/STITCHED PREFORM
• KNIT/STITCH PREFORM, APPLYING FILM RESIN; RFI PROCESS; PRE-PARE FOR AUTOCLAVE PROCESSING; AUTOCLAVE CONSOLIDATE PART; REMOVE PART; TRIM TO FINISH DIMENSIONS				
TOTALS	123.12	125.53	102.00	

NOTE: THE STANDARD AUTOCLAVE TAPE FABRICATION OF Y SPAR REQUIRES 129 PERSON HR

Labor Costs

Manufacturing hours to produce the individual Y spars are also tabulated in Table I. Person-hour estimates for the autoclave-consolidated-13 Y spar are based on a single autoclave cycle being required, including an overnight preheating at 350°F. Person hours for the RTM and RFI/autoclave processes performed at a subcontractor were derived by dividing the vendor's cost to Grumman by a labor rate of \$100.00/hr. Similarly, person hours listed for the weaving and stitching of the -11 and -13 preforms were derived from the subcontractors' dollar costs to Grumman. The person-hour estimates given in Table I are average values, and do not reflect a learning curve.

Based on the tabulated data, person-hour requirements for the three fabrication approaches are:

- RTM processing of knitted/stitched Y spar: 123.12
- Autoclave consolidation of woven commingled PEEK Y spar: 125.52
- RFI/autoclave processing of knitted/stitched Y spar: 102.00.

Material Costs

Most material costs for the Y spars under the three competing processing techniques were included in the data summarized in Table I. Therefore, Table II includes only the material costs associated with the autoclave consolidation of the woven commingled PEEK Y spars at Grumman. These include costs of all breather and bagging materials required to support the autoclave operation itself, as well as the liquid nitrogen consumed in the autoclave cycle. The data are estimates based on observation of material usage during the bagging operation, or on average consumption of gas. From Table II, the material costs for the autoclave manufacturing approach are \$1767.00.

Facility Costs

The full-scale production of Y spars, using each of the candidate manufacturing approaches, would require the following equipment:

- High-temperature/high-pressure autoclave
- Hydraulic press
- Vacuum pumps
- Metering/injection equipment to support RTM
- Other miscellaneous facilities to support the above capital equipment.

Isolating the costs of these types of facilities was beyond the scope of this program.

TABLE II. - MATERIAL COST FOR AUTOCLAVE CONSOLIDATION OF -13 Y SPAR

MATERIAL (DESCRIPTION)	UNIT COST (\$)	USAGE	COST (\$)
BREATHER FABRIC (STYLE 181 FIBERGLASS)	1.50/YD ²	10 YD ²	15.00
VACUUM BAG SEALANT (HIGH-TEMPERATURE)	25/ROLL	6 ROLLS	150.00
(LOW-TEMPERATURE)	5/ROLL	2 ROLLS	10.00
VACUUM BAG FILM (KAPTON)	6/YD	4 YDS	24.00
KAPTON TAPE	28/ROLL	1 ROLL	28.00
INDUSTRIAL GAS (LIQUID NITROGEN) & RELATED COSTS	28/GAL	55 GAL	1540.00
TOTAL COST			1767.00

MR91-6880-035

Comparative Manufacturing Costs

Labor costs for the three manufacturing approaches, assuming a labor rate of \$100.00/hr, would be as follows:

- RTM-processed knitted/stitched Y spar: \$12,312.00
- Autoclave-consolidated woven commingled PEEK Y spar: \$12,552.00
- RFI/autoclave-processed knitted/stitched Y spar: \$10,200.00.

Adding to the autoclave consolidation approach the separate material costs of \$1767.00, as identified above and in Table II, would provide the following total comparative costs for the three processes:

- RTM-processed knitted/stitched Y spar: \$12,312.00
- Autoclave-consolidated woven commingled PEEK Y spar: \$14,319.00
- RFI/autoclave-processed knitted/stitched Y spar: \$10,200.00.

Based on the comparative manufacturing costs for each Y spar and assuming applicability to future aerospace components, the RFI/autoclave process could provide 17 and 29% lower fabrication costs, respectively, than the other competing processes.

CONCLUSION

The study conducted as herein described has led to the following various conclusions:

- Textile polymer matrix composites (PMC) can be designed and fabricated for primary aircraft structural components with equivalent efficiency and reduced acquisition costs compared with current day PMC components (approximately 20% reduction)
- The various PMC materials, along with various processing methods, are all suitable for wing spar applications and thus provide for design/manufacturing flexibility
- Although the various processes have not yet been developed to a fully reliable state, with continued study it appears that full-scale components will be production implemented in the future.