

TEST RESULTS FROM LARGE WING AND FUSELAGE PANELS

**Ram C. Madan and Mike Voldman
Douglas Aircraft Company
McDonnell Douglas Corporation
Long Beach, CA**

520-24
51305

SUMMARY

This paper presents the first results in an assessment of the strength, stiffness, and damage tolerance of stiffened wing and fuselage subcomponents. Under this NASA-funded program, 10 large wing and fuselage panels, variously fabricated by automated tow placement and dry-stitched preform/resin transfer molding, are to be tested.

The first test of an automated tow placement six-longeron fuselage panel under shear load was completed successfully. Using NASTRAN finite-element analysis the stiffness of the panel in the linear range prior to buckling was predicted within 3.5 percent. A nonlinear analysis predicted the buckling load within 10 percent and final failure load within 6 percent. The first test of a resin transfer molding six-stringer wing panel under compression was also completed. The panel failed unexpectedly in buckling because of inadequate supporting structure. The average strain was 0.43 percent with a line load of 20.3 kips per inch of width. This strain still exceeds the design allowable strains. Also, the stringers did not debond before failure, which is in contrast to the general behavior of unstitched panels.

INTRODUCTION

While application of composites in secondary and medium primary structures has produced worthwhile weight savings, wing and fuselage primary structures offer a far greater opportunity because these structures comprise approximately 75 percent of the total structural weight of a large transport aircraft. As part of efforts to develop the composite primary structure, a comprehensive test program, ranging from coupon testing to subcomponent verification tests, was initiated to demonstrate the behavior of components utilizing automated tow placement (ATP) and resin transfer molding (RTM) techniques.

The objectives of this program were to validate experimentally a number of wing and fuselage panel designs, to provide correlation data for analytical predictions of failure loads and failure modes, and to provide scale-up data for wing boxes and fuselage sections. In the early phases of this program, several test elements were designed, fabricated, and tested (Reference 1). These included pull-off tension, single-stringer crippling, and three-stringer compression specimens. This activity was then extended to cover subcomponent primary structure. Work done under prior NASA contracts (References 2 and 3) generated the design concepts for the ATP and stitched RTM fuselage and wing panels.

The subsequent NASA Innovative Composite Advanced Primary Structure (ICAPS) program extends this work to subcomponents appropriate to the primary structure of a large transport aircraft. The relevant portion of this program is presented in this paper, together with the test results thus far.

ICAPS PANEL TEST PROGRAM

Under Phase A of the ICAPS program, 10 large panels fabricated by ATP and RTM are to be tested in shear or compression (Table I). These panels represent typical structural arrangements for major components of a fuselage and wing. The specific geometries employed were drawn from two McDonnell Douglas projects. The panels are related to the MD-100 120-inch-radius fuselage barrel and the MD-XX inner wing. The plan calls for seven of the panels to be fabricated using the RTM and dry-stitched preform technique. Uniwoven AS4 fabric is used with 1895 Shell resin for the fuselage and 3501-6 resin for wing subcomponents. The use of these materials, in combination with the stitching technique, is intended to result in an effective and low-cost structure. The other three panels were fabricated by Hercules from the toughened IM7/8551-7 composite system using the ATP method. One of the RTM wing compression panels has an 18- by 15-inch elliptic hole to accommodate a glass/epoxy access door. Similarly, one of the RTM fuselage shear panels incorporates two reinforced fuselage windows.

Each of the panels described in Table I is to be damaged before the test, three of the panels suffering penetration damage. After each test, results will be correlated with predictions.

PANEL TESTS

ATP Fuselage Subcomponent Tests

The fuselage subcomponent specimen is shown in Figure 1. The J-stiffened curved six-longeron panel (56 inches long and 48 inches wide with a 126-inch radius) was constructed by Hercules using the ATP technique. Three composite Z-section frames were attached to the panel by shear clips. Three panels were fabricated and the first of these was subjected to a shear test carried out at Douglas.

Prior to the shear test, the panel had been impacted with 20 foot-pounds of energy on the skin side at midlength of the third longeron between the upper and middle frames. A 1-inch steel impactor was employed in this test. The panel was supported along the outer longitudinal sides by wooden supports during the impact, as shown in Figure 2. The affected area was marked and is shown in Figure 3.

For the shear test, the panel was attached to the fixture by means of a steel hat-section frame around the four sides to provide flexibility so as to discourage premature failure at the corners (Figure 3). The Douglas shear fixture is shown in Figures 4 and 5. The panel was connected to the hat-frame with angle section attachments, and the hat-frame was fastened to the shear fixture picture frame.

When the panel was in place in the fixture, it was instrumented with strain gage rosettes, as shown in Figure 6. The rosette leads were connected to the data acquisition system. A hydraulic actuator was employed to pull down the right lower corner of the picture frame (Figure 3) so as to load the panel in shear. A calibrated extensometer was used to record vertical displacement. The data from all the channels were recorded and stored on a disk for plotting and further investigation. The load was applied at 0.05 inch per minute.

Test Results and Discussions

When the load exceeded 30,000 pounds, the panel began to buckle. As the load was increased beyond buckling, the diagonal tension field formed in every bay of the panel. These wrinkles were

clearly observable from the skin side of the panel. When the load exceeded 70,000 pounds, a cracking sound was heard. This could be attributed to either some local longeron debonding or a few separate tows of fiber breaking. Overall, the structure stayed intact until it failed catastrophically at 100,000 pounds.

Figures 7 through 11 show close-up pictures of the damage in different parts of the panel. Almost all the damage occurred across the main tension diagonal where a big wrinkle was formed, as shown in Figure 7. The impacted area happened to be away from the main diagonal and did not influence the onset of damage, nor was this area damaged as the panel failed. The damage shown in the upper right corner of Figure 8 and upper left corner of Figure 9 can be attributed to the high intensity of compressive stress in that region. The failure propagated along the main diagonal and subsequently caused the longerons to debond and break. Figure 8 shows the skin wrinkled, broken, and delaminated under the longerons and the skin longeron broken in the area where it separated from the skin. Figure 9 shows the skin delaminated in the corner and broken along the crest of the wrinkle. Figures 10 and 11 show the stringers broken and debonded from the skin. Typical damage on the shear tees and frames is shown in Figures 12 and 13.

A NASTRAN model of the panel is shown in Figure 14, while the material and lay-up of each element are shown in Table II. The load deflection curve is shown in Figure 15 and some typical results from back-to-back strain rosettes data are presented in Figure 16. Shear strains were calculated using the right angle rosette formula and were plotted on the same graphs. A good correlation was found between the test results and the predictions of the analytical model of the tested panel.

The model was analyzed in the linear and nonlinear postbuckled state using NASTRAN Solution 5 for linear static and eigenvalue analysis and Solution 66 for large displacement type nonlinear stress analysis. The load deflection curves obtained by both the test and the analyses are compared in Figure 15. As shown, the stiffness of the panel in the linear range was predicted within 3.5 percent. The initial onset of buckling predicted by linear buckling analysis (Solution 5 NASTRAN) was within 20 percent of the value measured in the test. This degree of accuracy was expected in applying FEA linear buckling analysis to the stiffened plates. A better result was obtained by using the nonlinear analysis (Solution 66), which predicted the buckling load within 10 percent. Solution 66 was also used to predict the final failure load, which was predicted within 6 percent of the value measured in the test.

Future Plans

Two additional ATP panels, as shown in Items 5 and 6 of Table I, will be tested in compression. As indicated in Table I, Item 5 will be loaded in compression until the panel begins to buckle. The panel will be unloaded, supported as shown in Figure 2, and impacted at the crest point of the buckled shape with 20-foot pounds of impact energy using a 1-inch-diameter steel impactor. The panel will be A-scanned to assess the damage area and will then be tested to failure. The test results will be compared with predictions made with the finite-element analysis models. The third ATP panel will be saw-cut as shown in Item 6 of Table I and will be loaded in compression to 70 percent of design limit load. If no failure occurs at this load, the panel will be unloaded and the saw-cut increased by 0.5 inch at each end. The panel will again be loaded to 70 percent of design limit load. This process will be repeated until the panel fails. All the data will be recorded and damage tolerance characteristics will be evaluated. The test results will be compared with predictions made with NASTRAN finite-element analysis.

RTM Fuselage Subcomponent Tests

Four curved RTM fuselage panels using stitched preforms were fabricated at Douglas. They are shown as Items 7 through 10 in Table I. As noted in the table, the first three panels will be tested similarly to the ATP panels in shear and compression. The fourth panel has two cutouts representing two fuselage windows, as shown in Figure 17, which will be tested in shear after impacting it with 20 foot-pounds of impact energy. The test results will be compared with analytical predictions.

RTM Wing Subcomponent Tests

Three RTM wing panels have been fabricated using stitched preforms to verify the composite damage tolerance requirements of FAR 25.571. One of the panels, with invisible impact damage, was tested in compression, while the other two will be tested in the future. The six-stringer wing panel configuration is shown in Figure 18.

The panel was simply supported at rib locations (31 inches apart) and impacted at midbay with 100 foot-pounds of energy from the skin side using a 1-inch-diameter steel impactor. The inflicted damage was invisible. A C-scan showing the extent of impact damage is presented in Figure 19. The damage was small, particularly when compared with the damage one would expect for a conventional toughened resin panel, where far-side delamination would be normal. The panel was instrumented with 20 strain gages, as shown in Figure 18. Figure 20 shows the panel in the MTS machine with lateral support. The panel was potted at the top and bottom edges using Hysol 934 potting material with a 1-inch-deep rectangular aluminum frame all around. Before formally applying the load, all the strain gage channels were checked by loading the panel to 30 percent of design limit load.

Test Results and Discussions

A six-stringer RTM panel was tested in the Hercules MTS 1.5 million-pound machine at Magna, Utah. The panel was loaded at the rate of 0.05 inch per minute. The data were recorded at load intervals of 50 kips when the panel was loaded from 0 to 500 kips and at intervals of 10 kips thereafter. As shown in Figures 21 and 22, a lateral restraint fixture was attached to the panel on the stringer side to stabilize it during compression loading. Linear variable-displacement transformers (LVDT), shown in Figure 23, were attached to the panel from the skin side to measure out-of-plane displacement. Two LVDTs were used to measure the vertical shortening of the panel. Another LVDT measured the expansion in width in order to determine the Poisson's effect. The load and strain data were recorded on a disk with a data acquisition system.

The plots showing displacement data from LVDTs are shown in Figure 24. Axial and transverse displacement data were found to be in agreement with Poisson's ratio. The strain gage data from two sets of back-to-back axial direction strain gages on the skin and stringer blade near the impact location are shown in Figure 25. These results indicate that the panel failed at 791.1 kips load with average strain of 0.43 percent and line load of 20.28 kips per inch. The predicted failure strain of 0.53 percent was obtained by using the parametric residual stress prediction model discussed in Reference 5. The preliminary posttest analysis indicates that the panel failed prematurely because of the insufficient stiffness of the lateral support. However, a few favorable results attributable to the stitching concept have been attained. First, the failure strain definitely exceeded the design strain allowable set by the bolted repair requirements. Second, a favorable comparison can be made with the state-of-the-art toughened epoxy composite systems (1808I/IM6) described in Reference 4:

- The stringers did not debond from the skin
- The cost of material and fabrication is lower

A summary comparison between the six-stringer RTM panel and the five-stringer prepreg panel is given in Table II. Although, as previously mentioned, the strain achieved exceeded the design level, it is considered probable that the failure strain would be even higher had the panel not failed prematurely. Photographs of the panel after the failure are shown in Figures 26 and 27.

Future Plans

Two additional wing panels (Table I, Items 2 and 3) are to be tested in compression. Panel 2 has the same dimension as Panel 1, but it has a 3-inch-wide, 1/8-inch saw-cut in one of the midstringers through the skin, flange, and blade. This panel test will satisfy the discrete source damage requirement for damage tolerance of composite aircraft structure. The panel will be loaded in compression to 70 percent of design limit load. If the panel survives this load, it will be unloaded and the saw-cut will be widened by 1 inch by increasing the cut 1/2 inch toward each adjacent bay. The panel will be loaded, and this process of increasing saw-cut size will be repeated until the panel fails at 70 percent or at a smaller load. The test results will be compared with analytical predictions.

The third RTM wing panel has an 18- by 15-inch elliptic opening to represent an access door. The opening will be covered with a glass/epoxy access door panel. The access door panel will be impacted with 100 foot-pounds of impact energy in a test conducted at the Hercules facility. A finite-element analysis will be conducted and the predictions compared with the test results.

CONCLUSIONS

ATP Fuselage Shear Panel

Results of the test indicated that the behavior of the panel closely agreed with the analytical predictions. Predictions were about 3.5 percent high for panel stiffness prior to buckling, in the proper vicinity for the onset of buckling, and 6 percent low for failure. Postbuckling failure load of the panel was about three times the buckling load.

RTM Wing Compression Panel

Under 100 foot-pounds of impact energy, the damage was not visible and appeared small in the C-scan. The panel was proven to be damage tolerant, particularly when compared with the damage one would expect for a conventional toughened resin panel, where far-side delamination would be normal.

The failure strain of the panel exceeded the design ultimate strain set by bolted repair requirements. Several favorable results were attained when comparison is made with the five-stringer panel fabricated with a state-of-the-art toughened resin system:

- Stringers did not debond from the skin.
- Higher failure strain (0.43 compared to 0.41). It is probable that the difference would be greater had the panel not failed prematurely.
- Lower cost of material and fabrication.

REFERENCES

1. Deaton, J. W.; Kullerd, S. M.; Madan, R. C.; and Chen, V. C: "Test and Analysis Results for Composite Transport Fuselage and Wing Structures," NASA Advanced Composites Technology Conference, Lake Tahoe, Nevada; November 4-7, 1991.
2. Sumida, P. T.; Madan, R. C.; and Hawley, A. V: "Test Results for Composite Specimens and Elements Containing Joints and Cutouts," NASA CR-178246, August 1988.
3. Madan, R. C.: "Composite Transport Wing Technology Development," NASA CR-178409, February 1988.
4. Madan, R. C.; and Shuart, M. J.: "Impact Damage and Residual Strength Analysis of Composite Panels with Bonded Stiffeners," Ninth ASTM Symposium on Composite Materials, Testing and Design; Sparks, Nevada; April 27-29, 1988.
5. May 1992 Technical Progress Report, "Innovative Composite Aircraft Primary Structures," NASA CRAD - 5909 TR 8430, June 26, 1992.

Table I. Wing and Fuselage Test Panels

ITEM	TEST PANELS	DIMENSIONS L X W (IN.)	DAMAGE TYPE / SIZE	TYPE OF TEST (ULTIMATE FAILURE)	REMARKS
1.	SIX-STRINGER RTM WING PANEL	56 X 39	100 FT-LB MIDBAY IMPACT	COMPRESSION	TESTED IN MAY 1992
2.	SIX-STRINGER RTM WING PANEL	56 X 39	3-INCH-WIDE SAW CUT IN STRINGER FLANGE AND SKIN	COMPRESSION	TO BE TESTED
3.	FOUR-STRINGER RTM WING ACCESS DOOR PANEL	56 X 39 18 X 12 OPEN- ING WITH DOOR	100 FT-LB IMPACT	COMPRESSION	TO BE TESTED
4.	SIX-LONGERON ATP FUSELAGE PANEL	60 X 48	20 FT-LB MIDLONGERON	SHEAR	TESTED IN FEB 1992
5.	SIX-LONGERON ATP FUSELAGE PANEL	56 X 39	20 FT-LB MIDSTRINGER	COMPRESSION	TO BE TESTED
6.	SIX-LONGERON ATP FUSELAGE PANEL	56 X 39	2-INCH-WIDE SAW CUT IN LONGERON FLANGE AND SKIN	BUCKLING / ULT COMPRESSION	TO BE TESTED
7.	SIX-LONGERON RTM FUSELAGE PANEL	60 X 48	20 FT-LB MIDLONGERON	SHEAR	TO BE TESTED
8.	SIX-LONGERON RTM FUSELAGE PANEL	56 X 39	20 FT-LB MIDLONGERON	BUCKLING / COMPRESSION	TO BE TESTED
9.	SIX-LONGERON RTM FUSELAGE PANEL	56 X 39	2-INCH-WIDE SAW CUT IN LONGERON FLANGE AND SKIN	BUCKLING / COMPRESSION	TO BE TESTED
10.	SIX-LONGERON RTM WINDOW BELT FUSE- LAGE PANEL	60 X 48 WITH TWO WINDOWS	20 FT-LB MIDLONGERON	SHEAR	TO BE TESTED

Table II. ATP Fuselage Panel Materials

Lay-ups:

Skin	(0, 90, 45, 0, -45, 90) s	8551-7/IM7 Tape
Longeron	(0, 45, 90, -45, 0) 2s	8551-7/IM7 Tape
Frame	(0/90, ±45) 3s	AS4/3501-6 Cloth
Shear Tee	(0.90, ±45) 3s	AS4/3501-6 Cloth

Table III. Wing Panel Test Results Comparison

	Stitched RTM	Toughened Resin* (Prepreg)
Panel	6-Stringer	5-Stringer
Damge Due to 100 ft-lb Impact	Not Visible	Far Side Delam
Line Load (kips/in.)	20.3	21.4
Strain (%)	0.43	0.41
Matl Modulus (msi)	9.85	10.05
Stress (ksi)	40.5	41.1
Failure Mode	Column Instability	Stringer Separation

***ASTM Conference (Nov 1989) by Shuart and Madan**

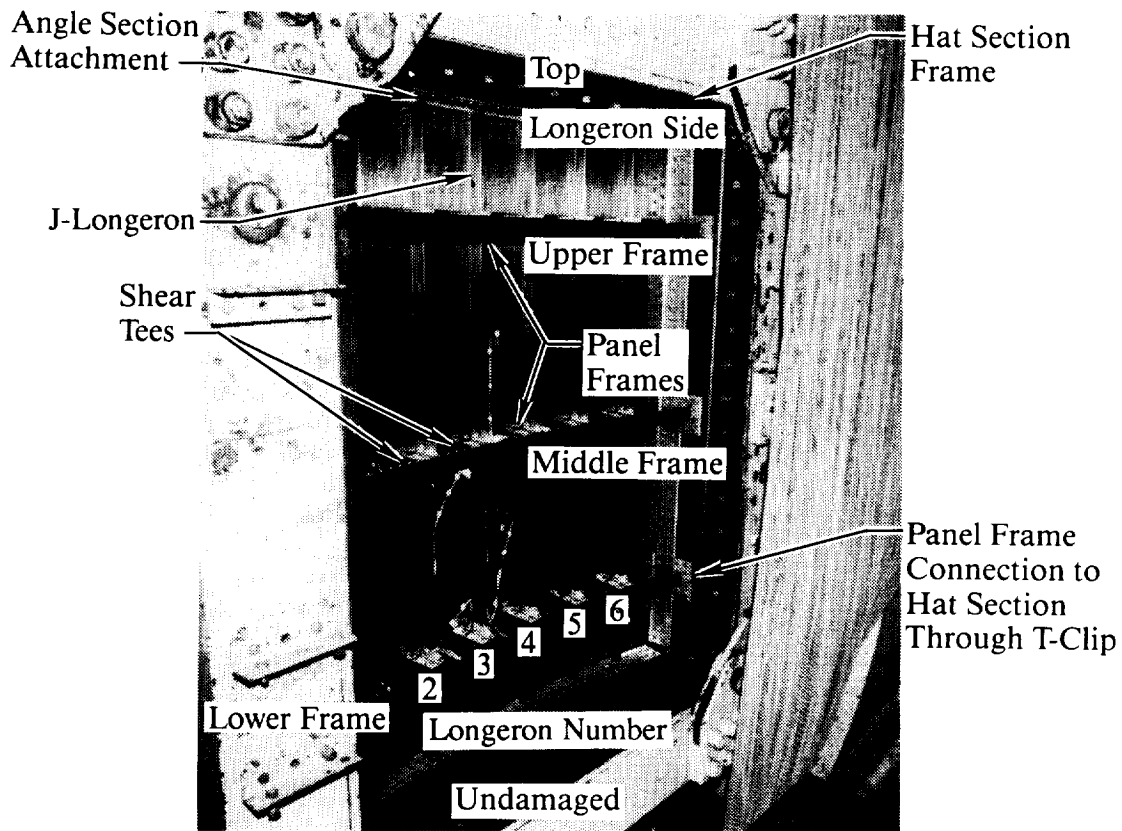
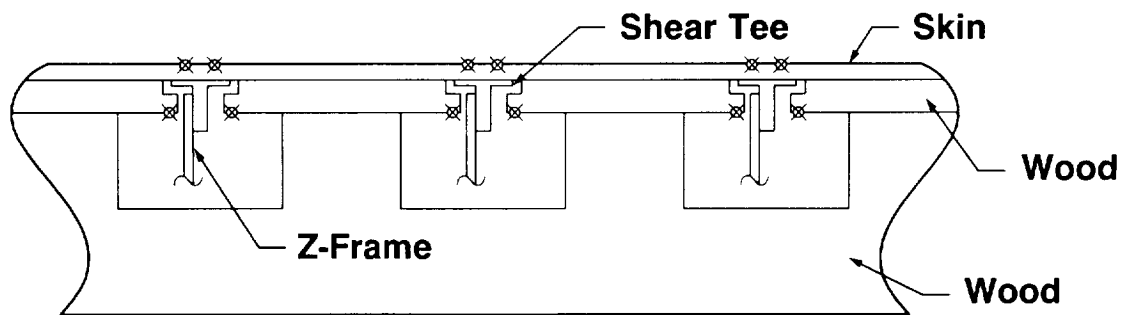

Figure 1. ATP six-Longeron fuselage panel in shear test fixture (longeron side)



✕ C-Clamps Support Points on Skin (Top) and Wood Sides (Bottom)

Wooden Support at Frame Ends (Two Req'd)

Figure 2. Impact support fixture

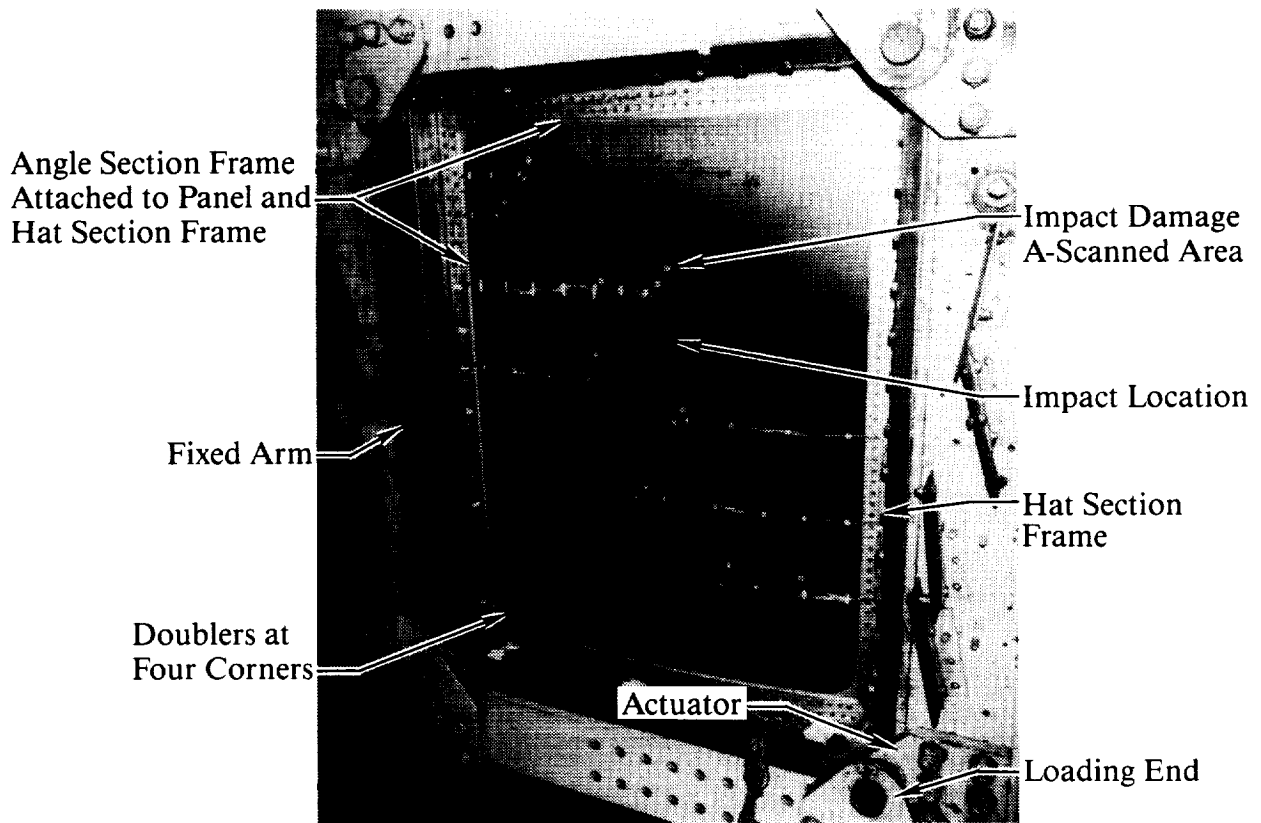

Figure 3. ATP six-longeron shear panel in test setup (skin side)

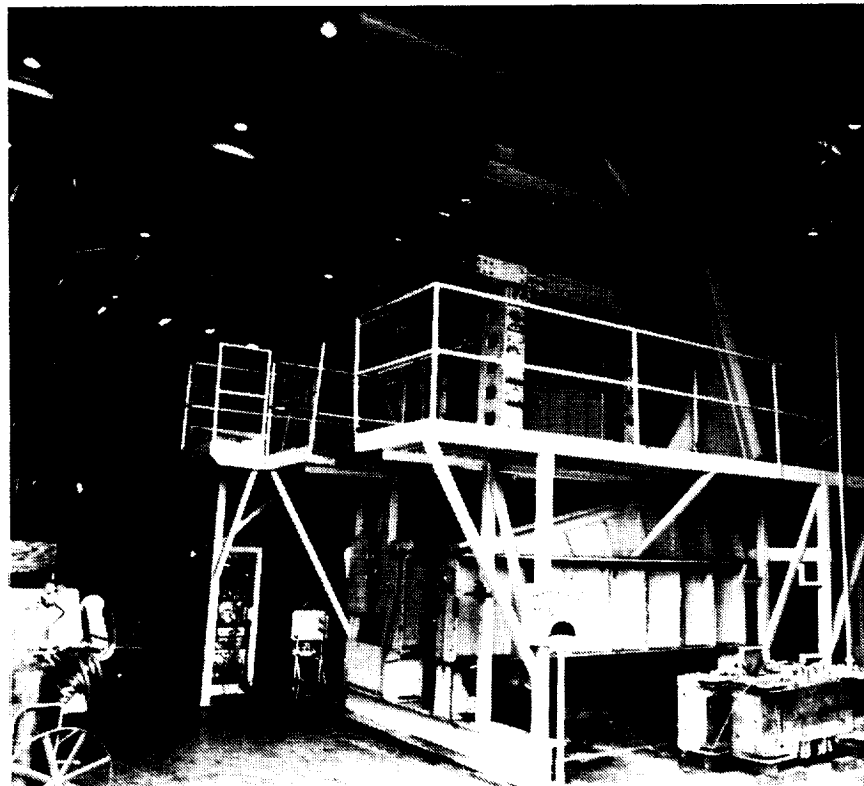

Figure 4. Shear test setup with panel (front view)

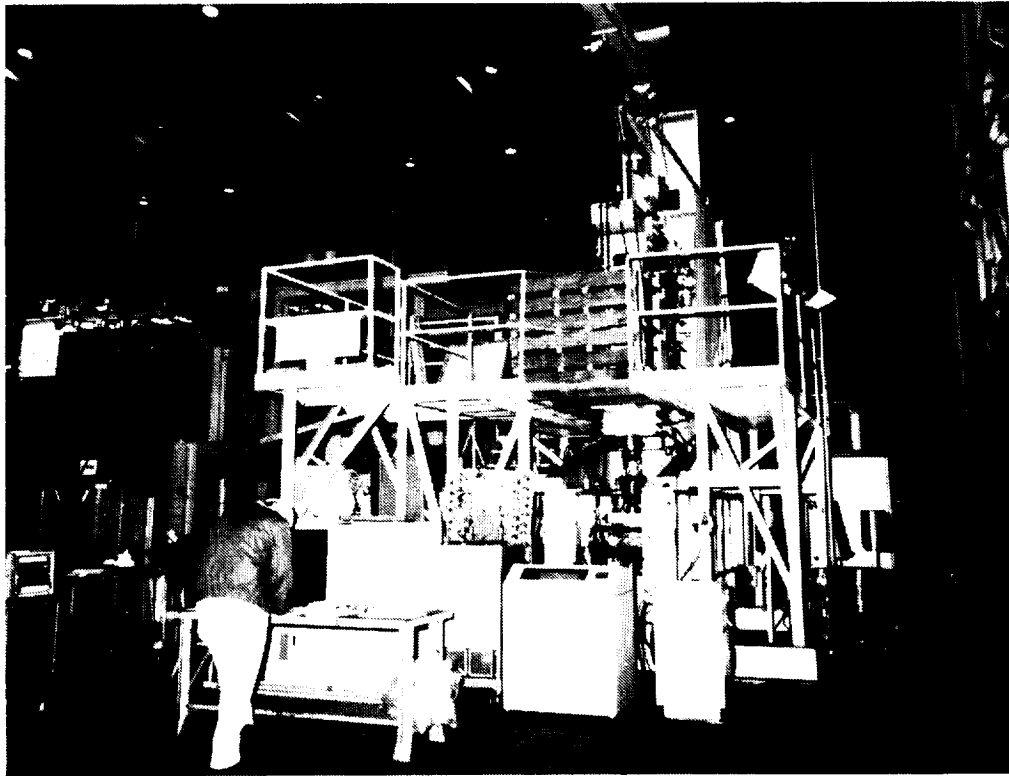

Figure 5. Shear test setup (side view)

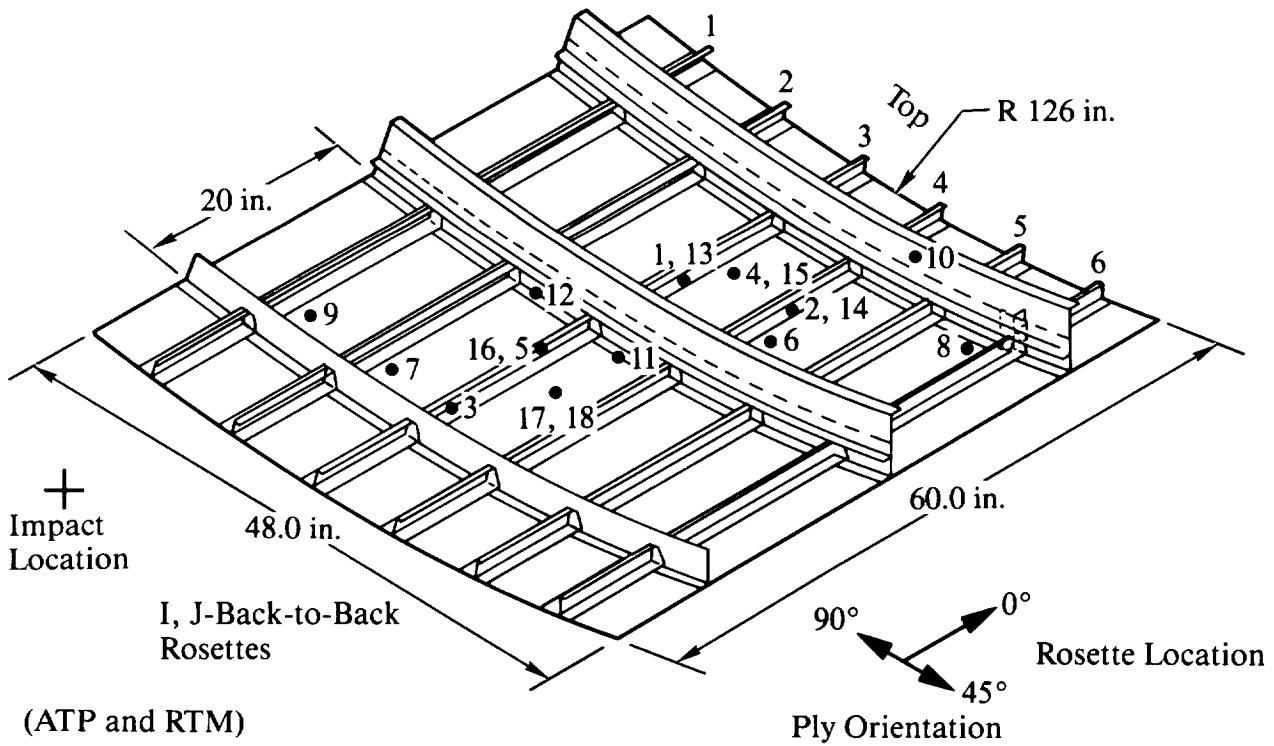

Figure 6. Six-J-stiffened fuselage shear test panel

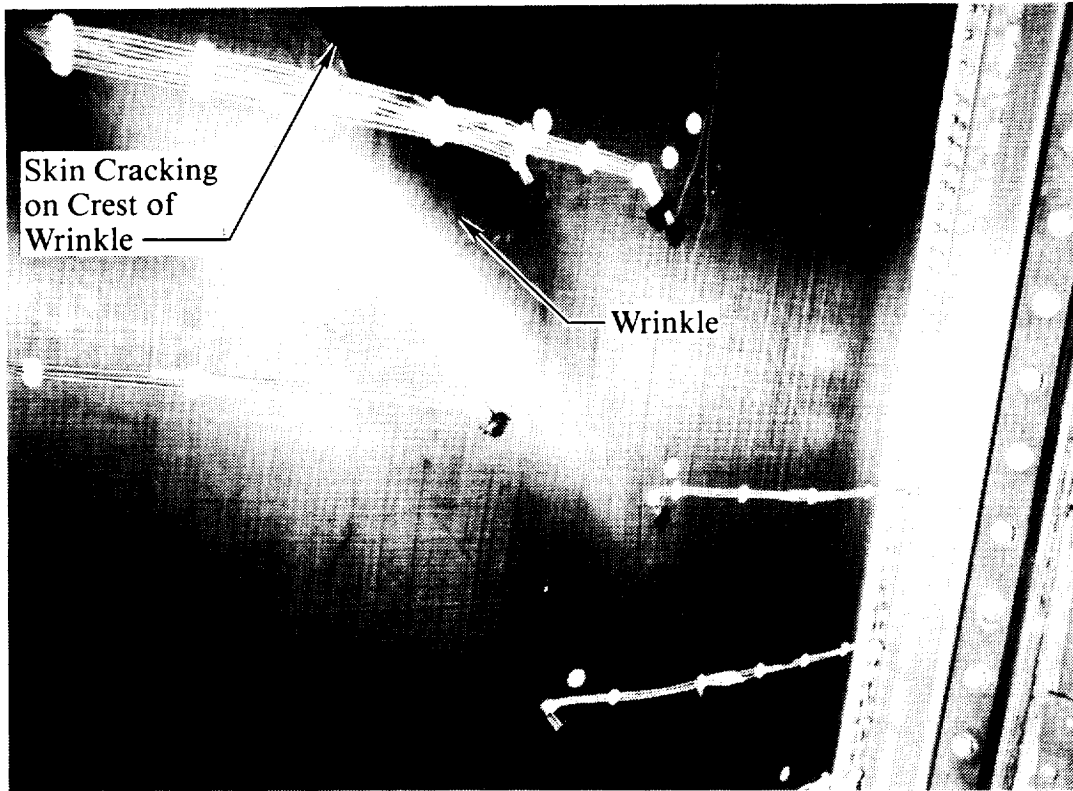

Figure 7. Buckling wrinkle in ATP fuselage shear test panel

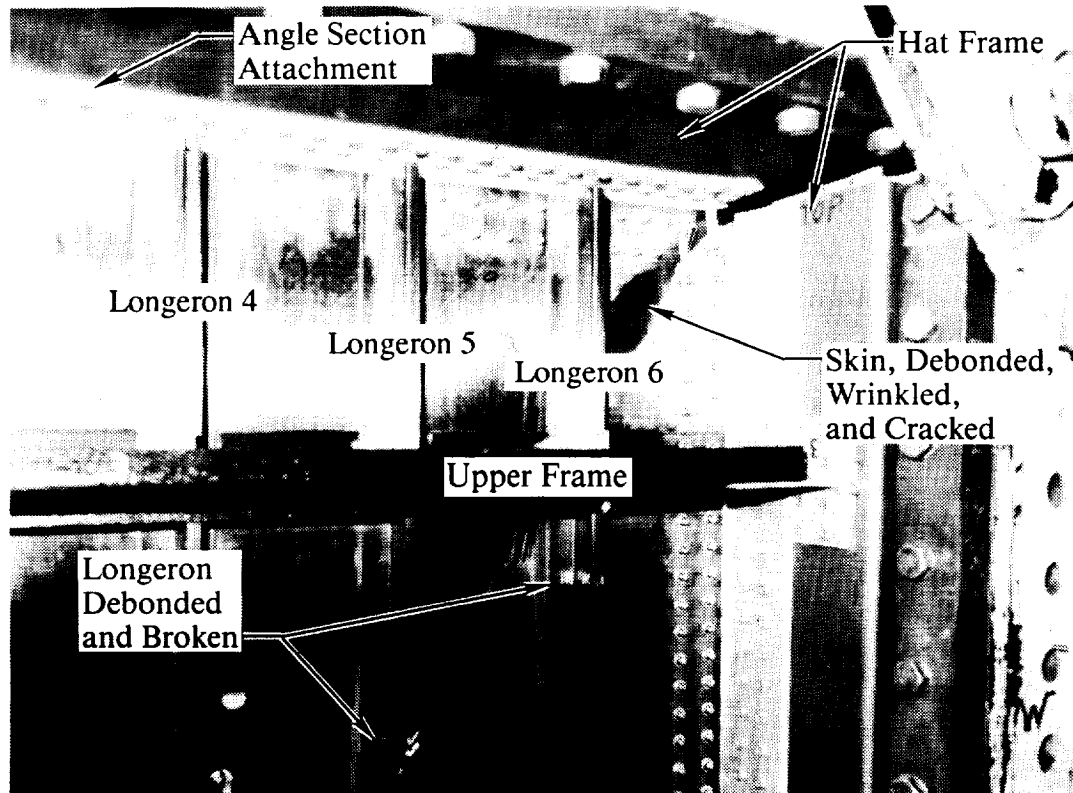

Figure 8. Damage in upper right corner of ATP shear panel

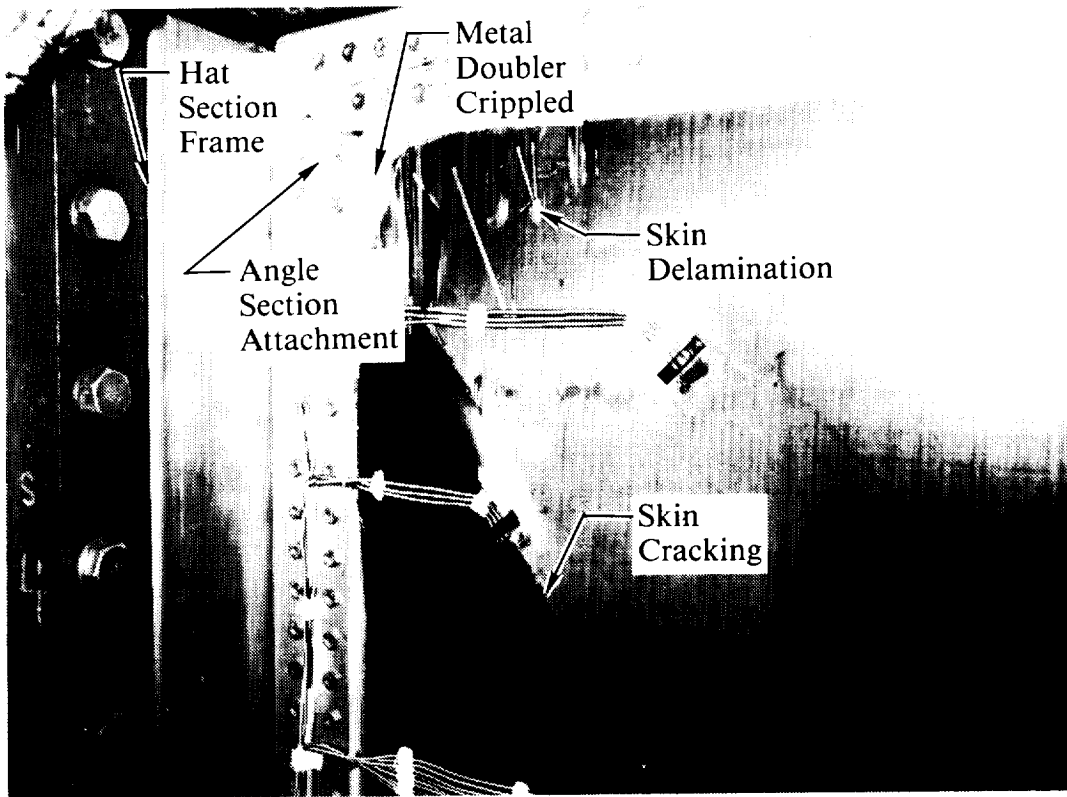

Figure 9. Damage in left top corner (skin side) in ATP shear panel (pinching effect)

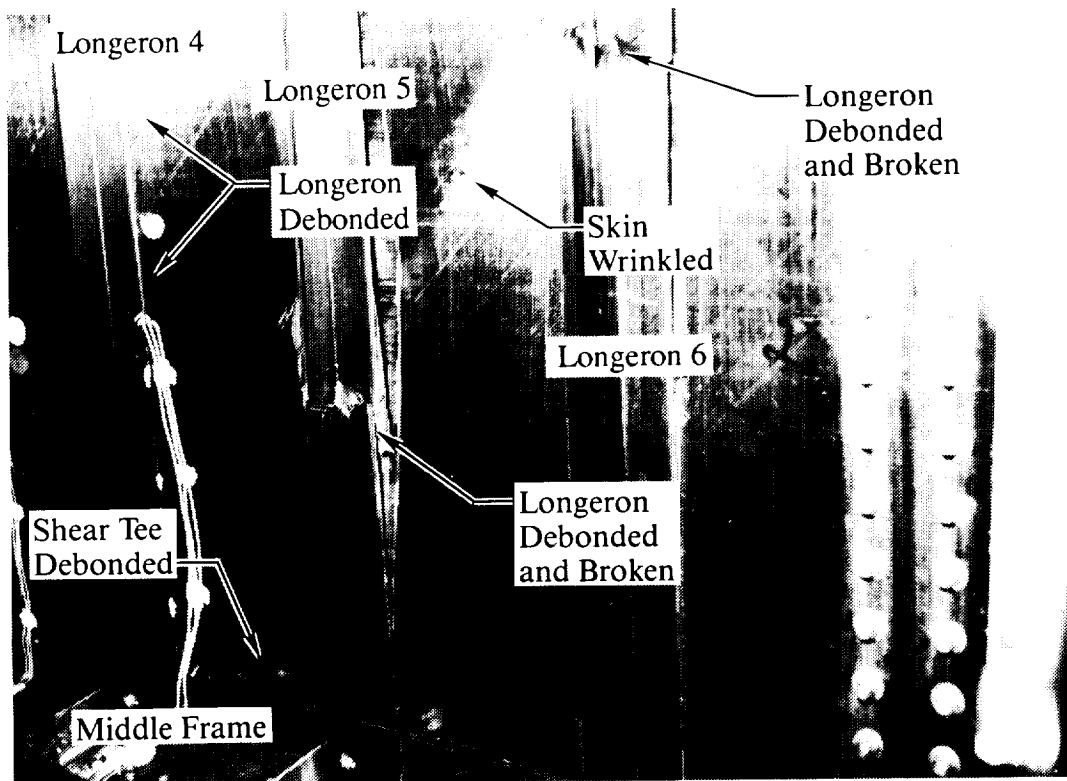

Figure 10. Damage above midframe in ATP shear panel

BLACK AREA IS PHOTOGRAPH

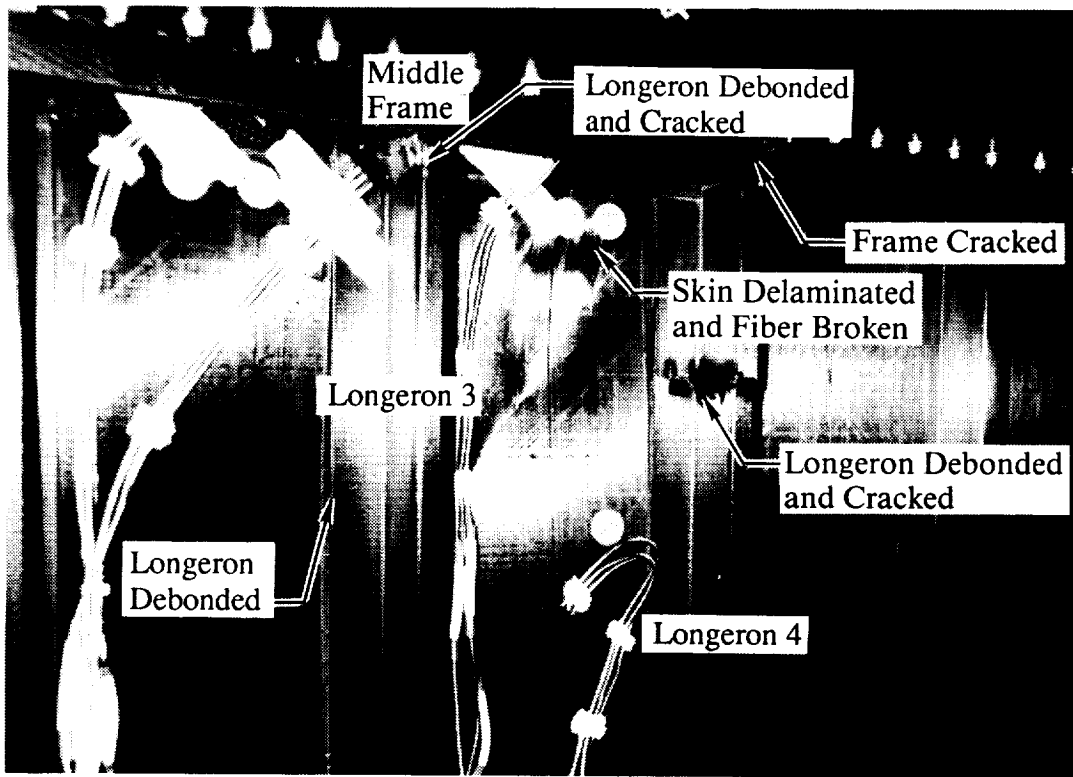

Figure 11. Damage below midframe in ATP shear test panel

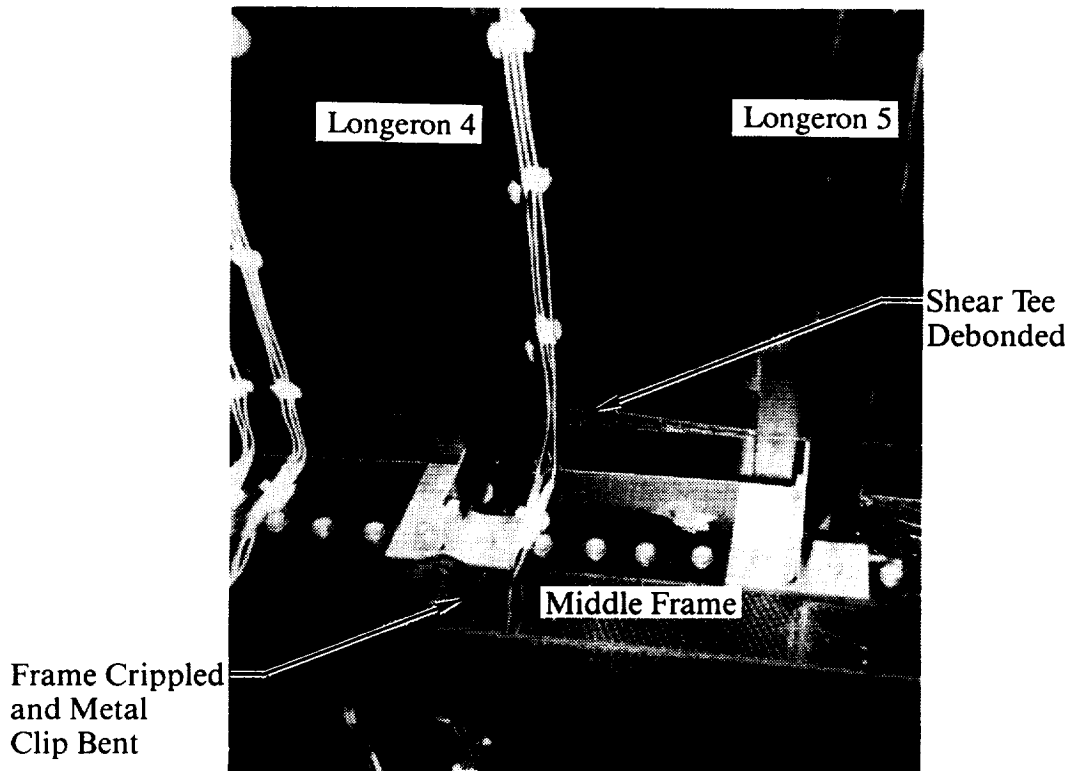

Figure 12. Damage above midframe in ATP shear panel

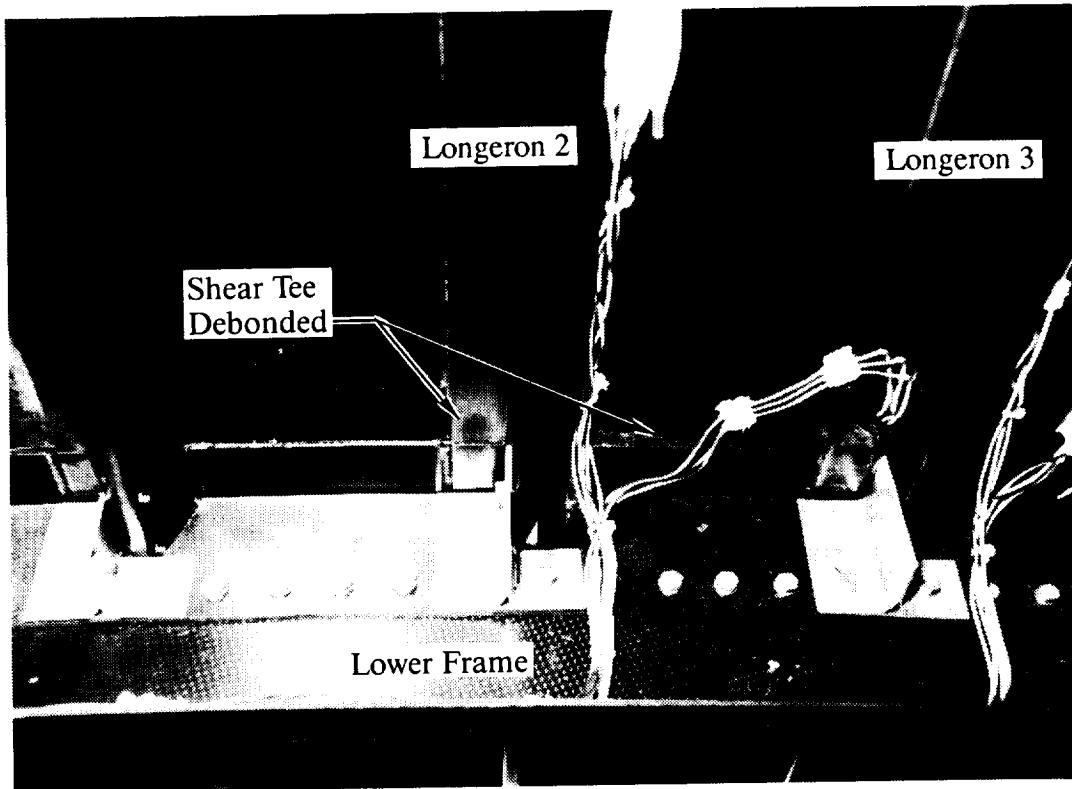

Figure 13. Damage in ATP shear panel test at midframe

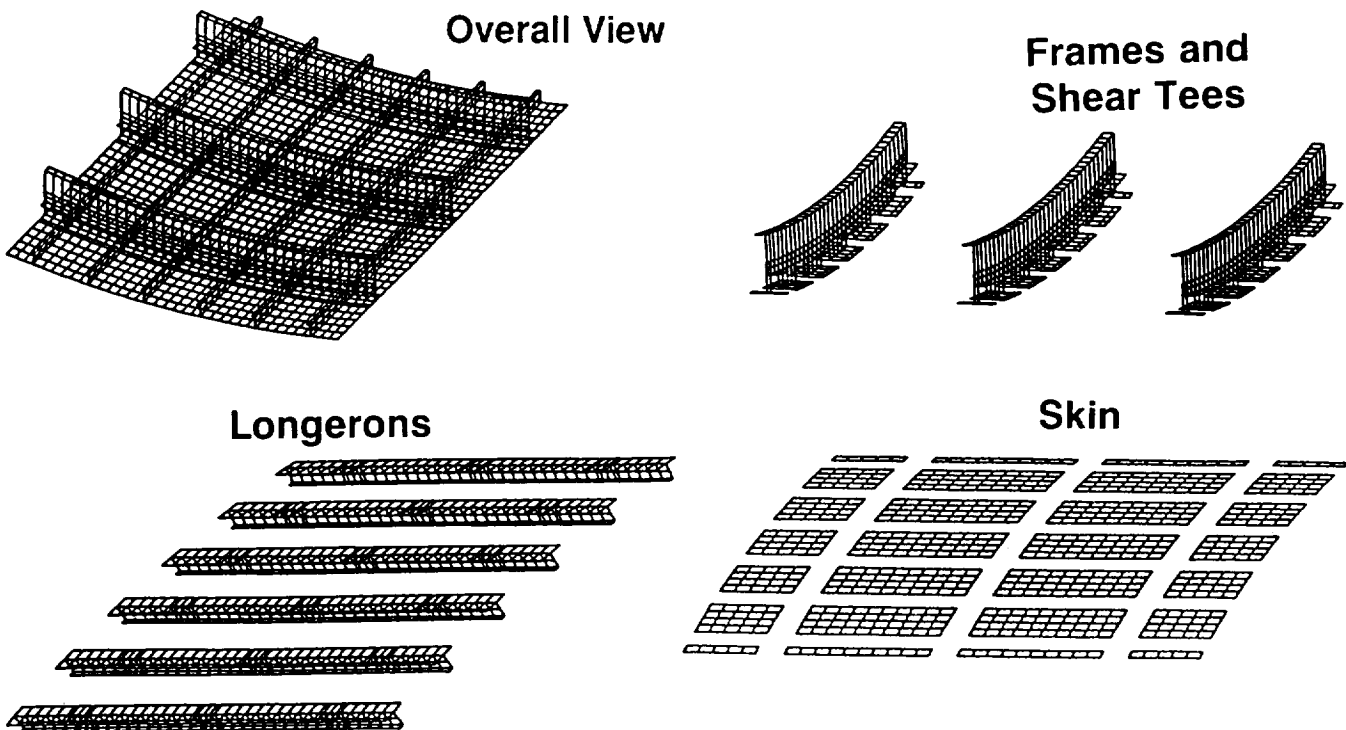

Figure 14. NASTRAN FEM model of the panel

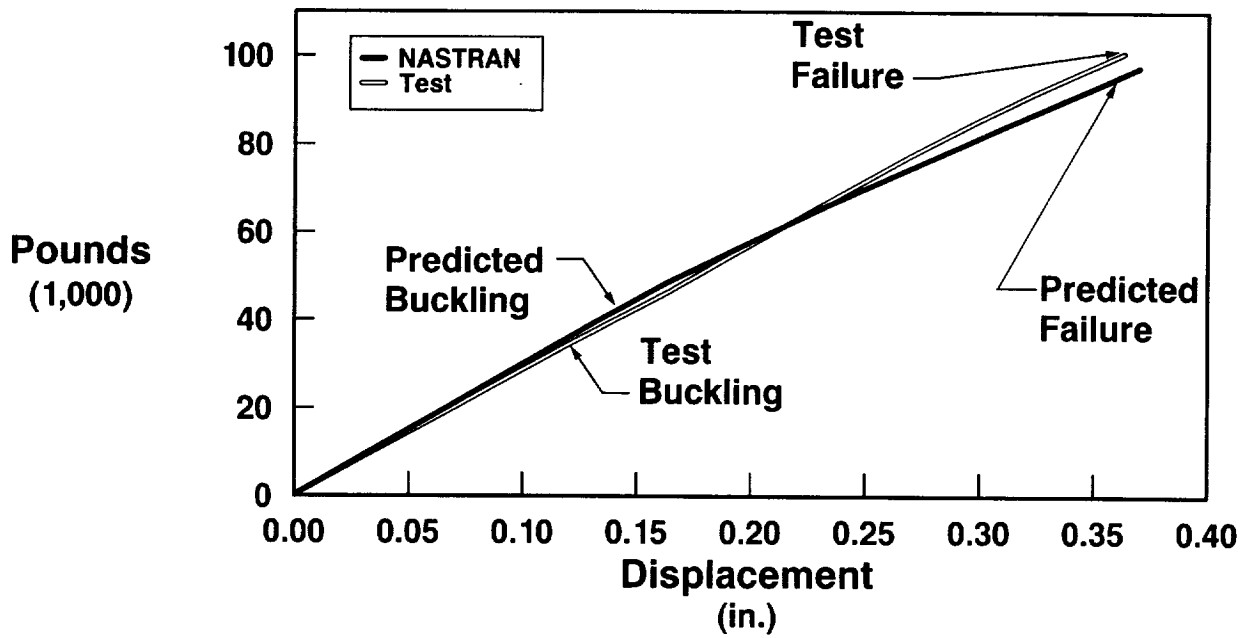

Figure 15. Panel nonlinear analysis shear postbuckling

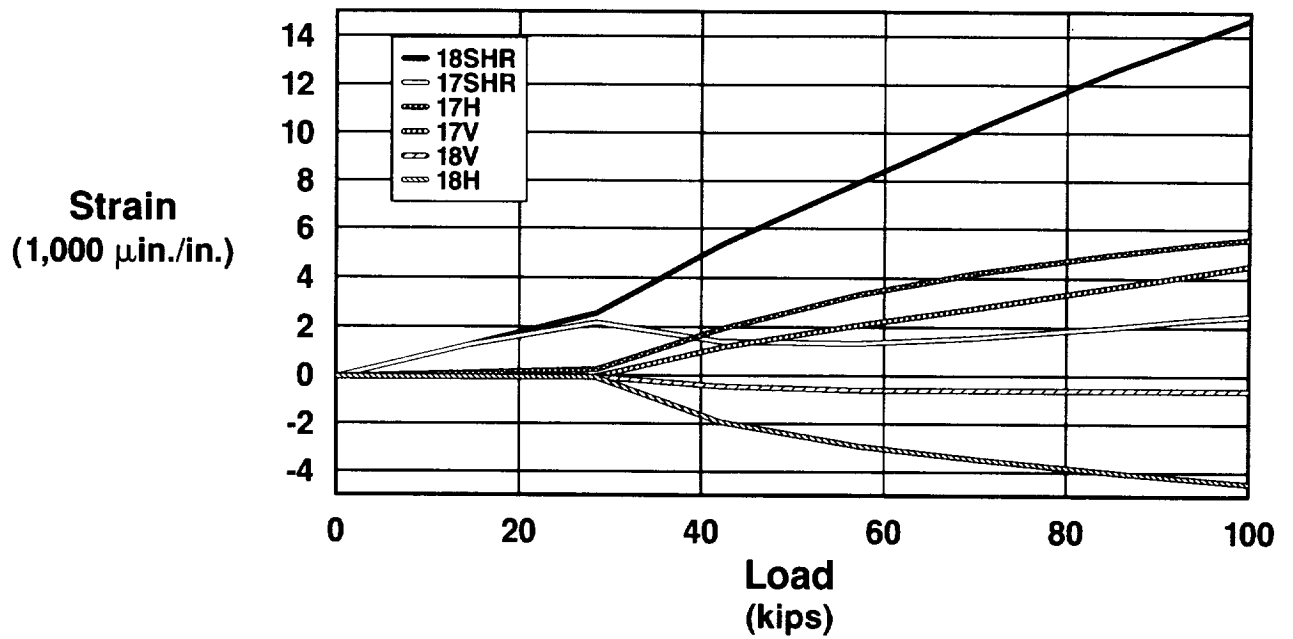

Figure 16. Six-longeron shear panel - Strain Gage 17 and 18 data

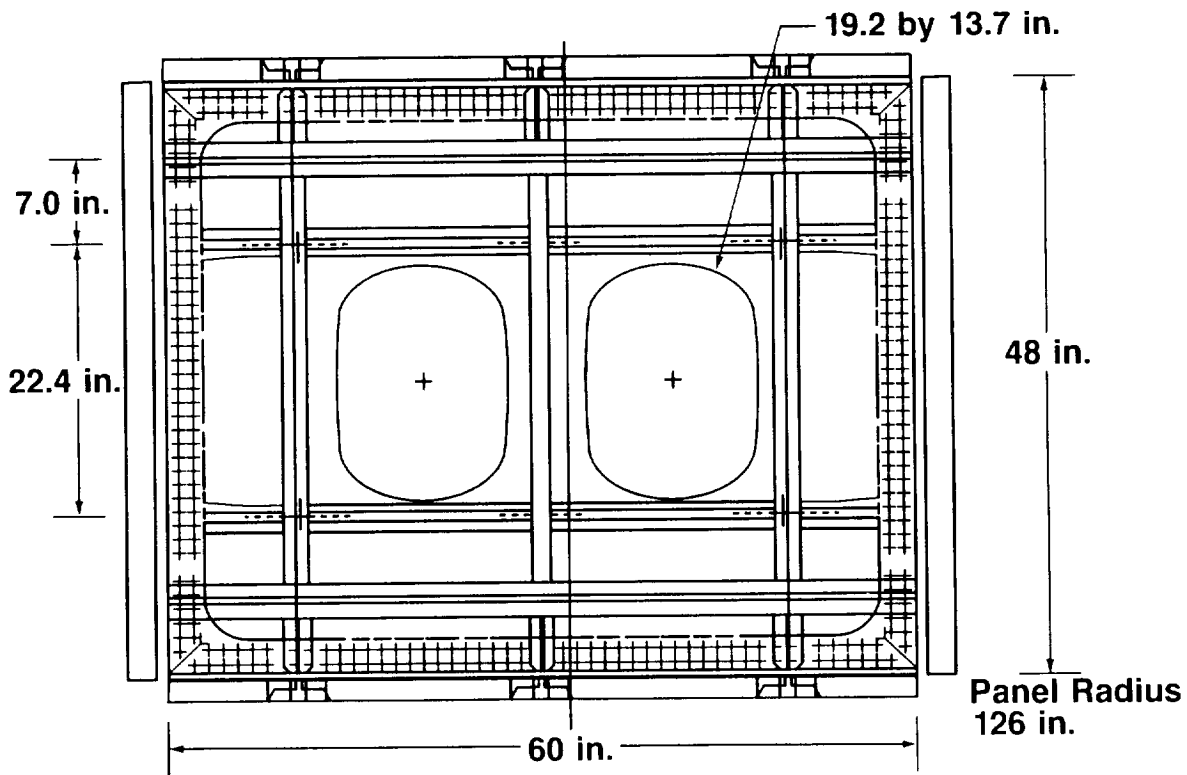

Figure 17. Window belt shear panel test

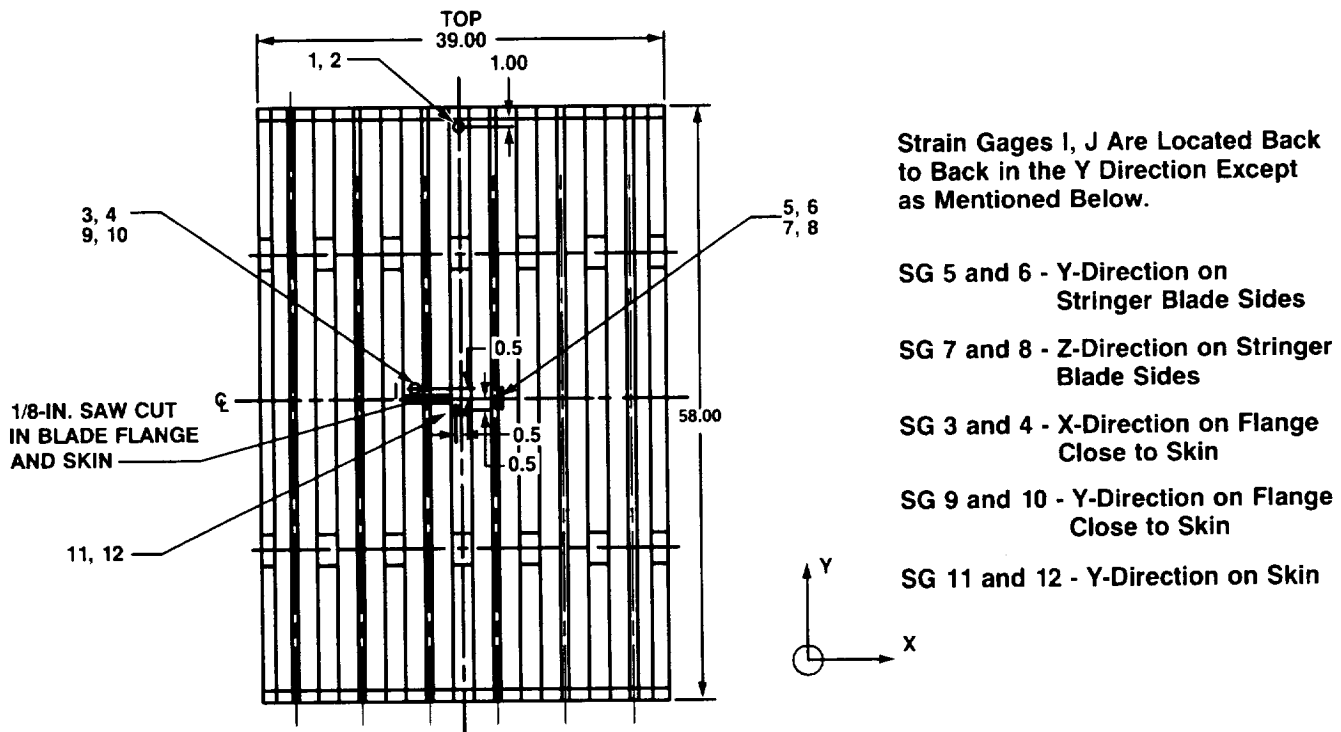

Figure 18. Strain gage locations for six-stringer RTM wing compression test panel

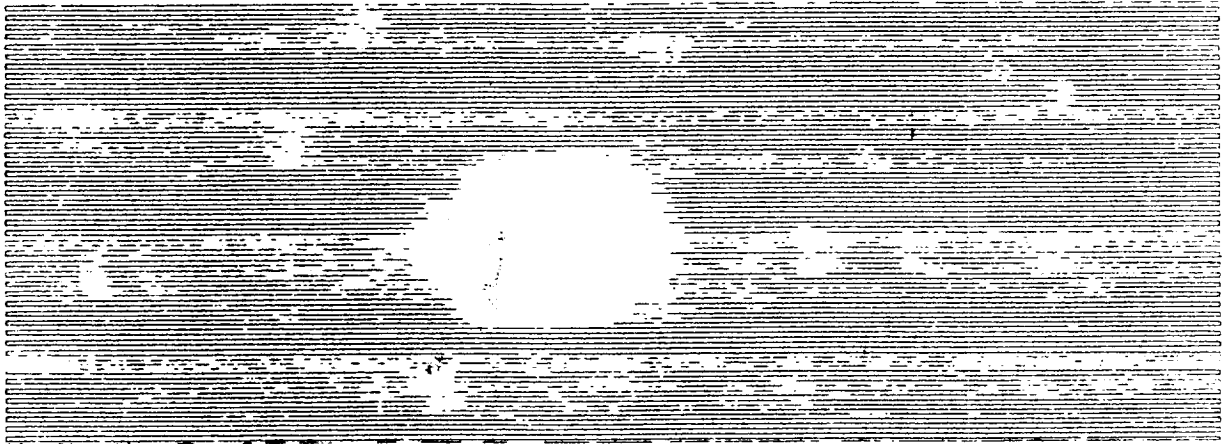

Figure 19. C-scan of midbay impact damage

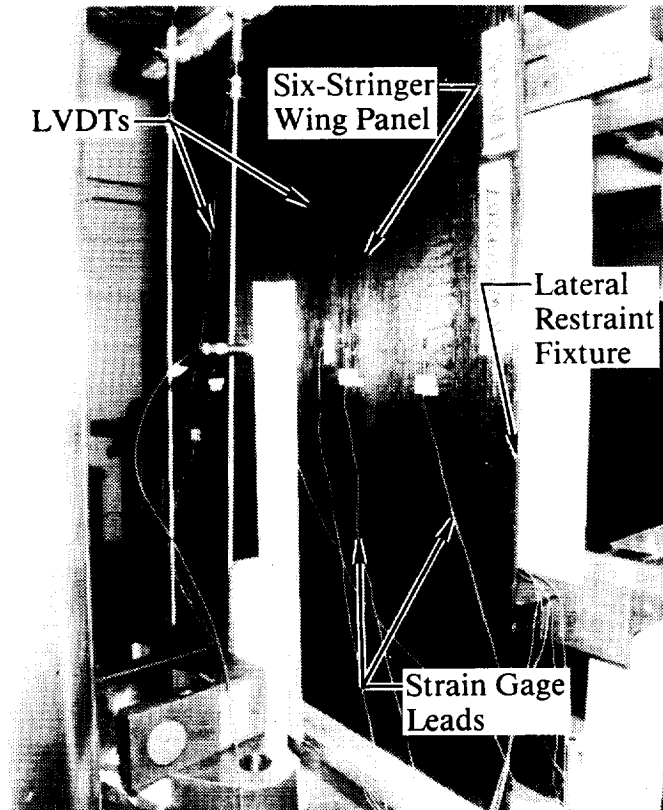
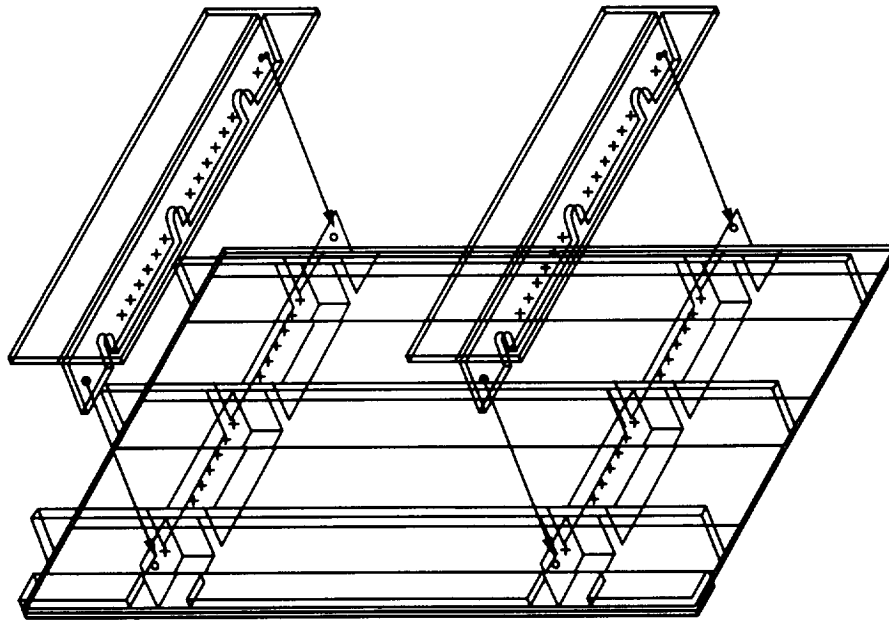

Figure 20. LVDT to measure out-of-plane deflection



Note: Similar Fixture Can Be Used for Two-, Four-, and Six-Stringer Panels

Figure 21. 3-D view of panel with lateral supports

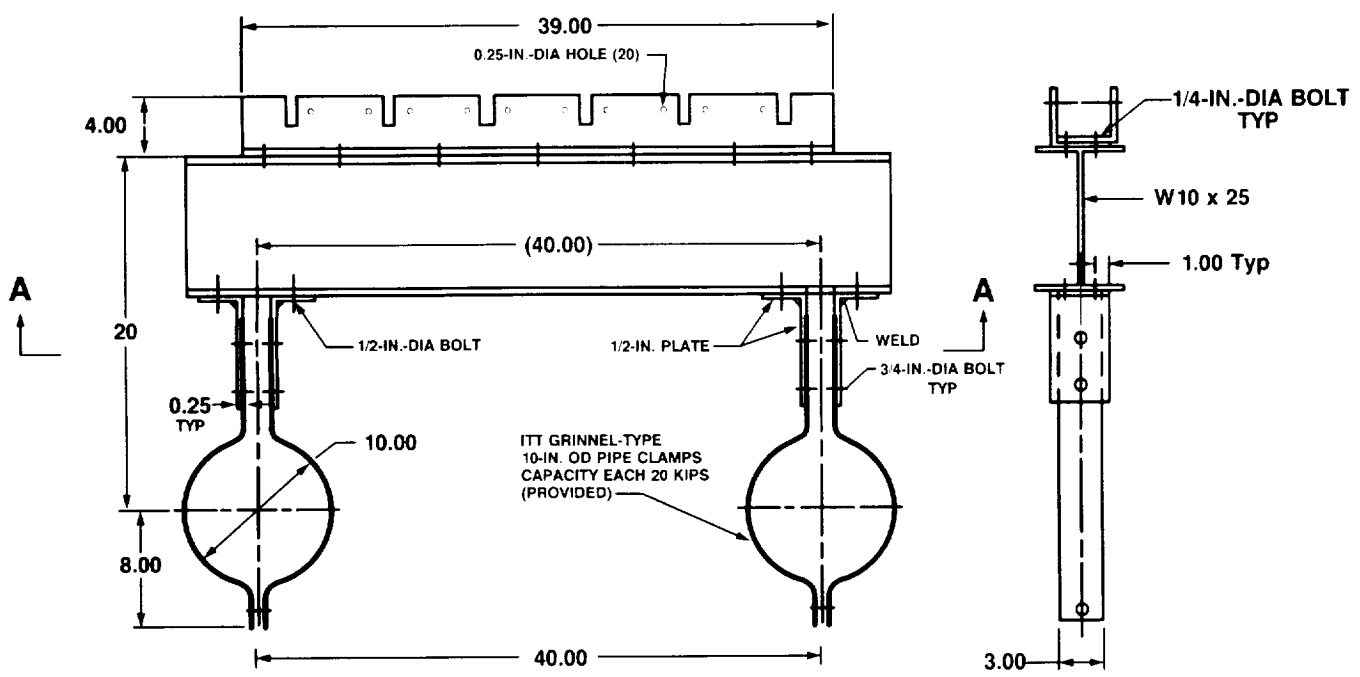

Figure 22. Lateral restraint fixture

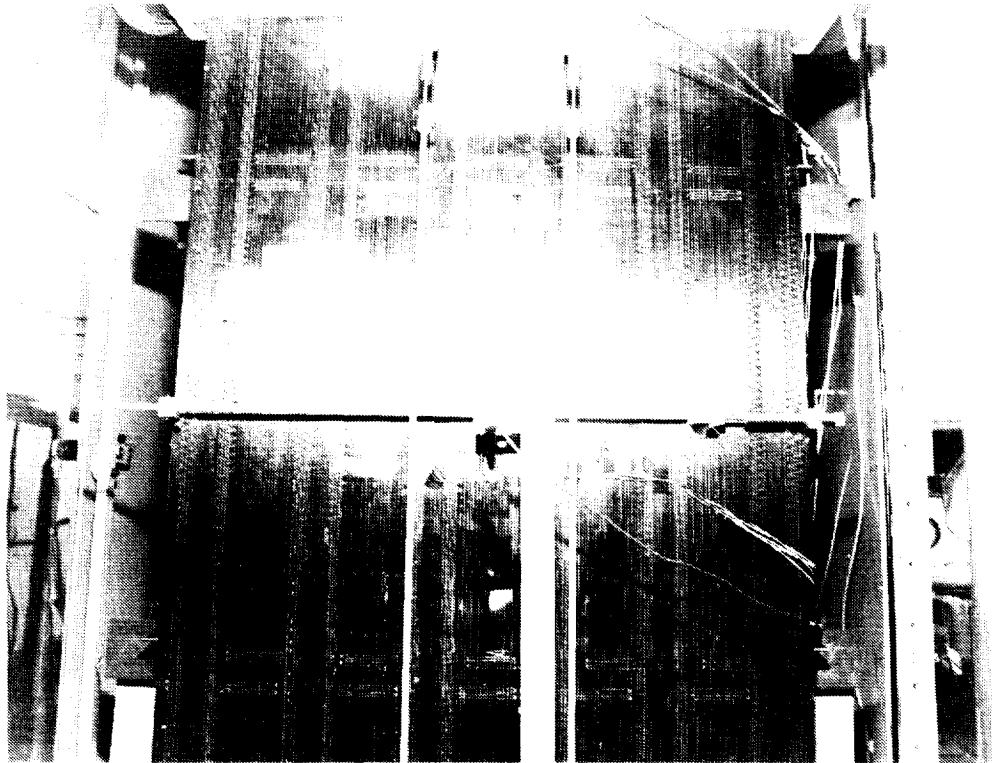

Figure 23. LVDTs on six-stringer compression test panel for displacement measurement

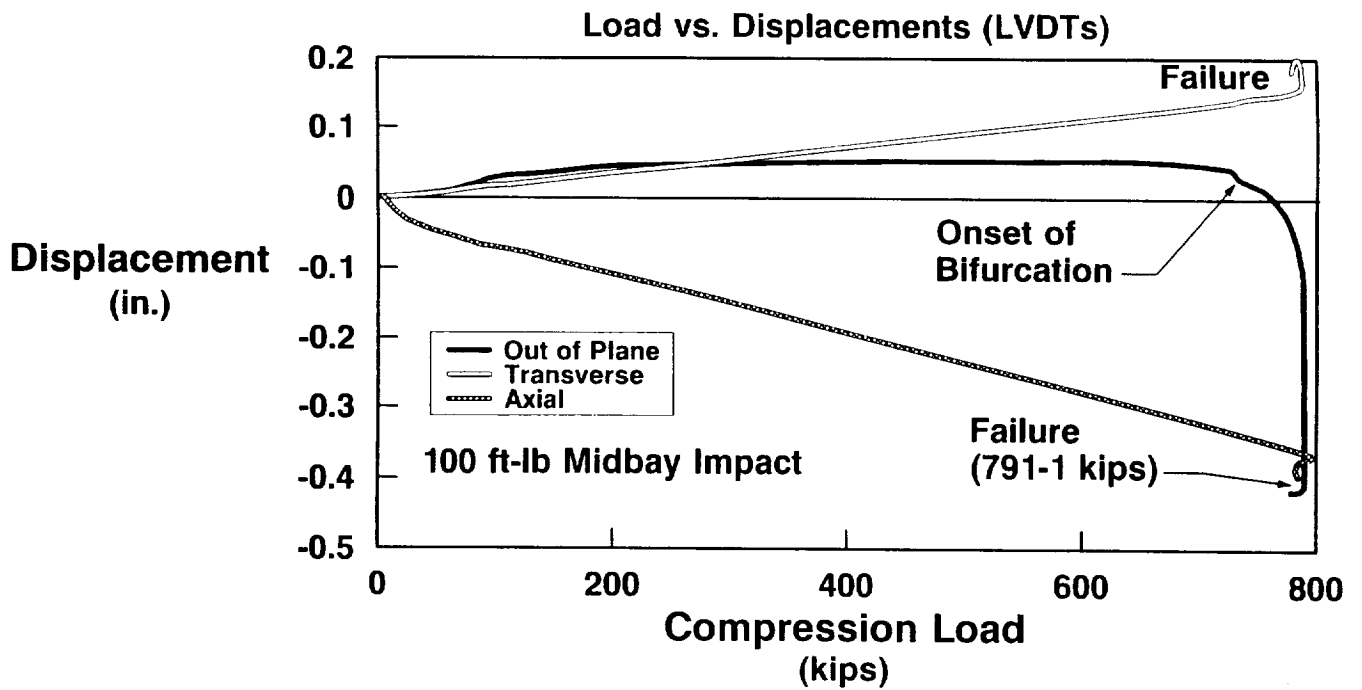

Figure 24. Six-stringer RTM wing compression panel test

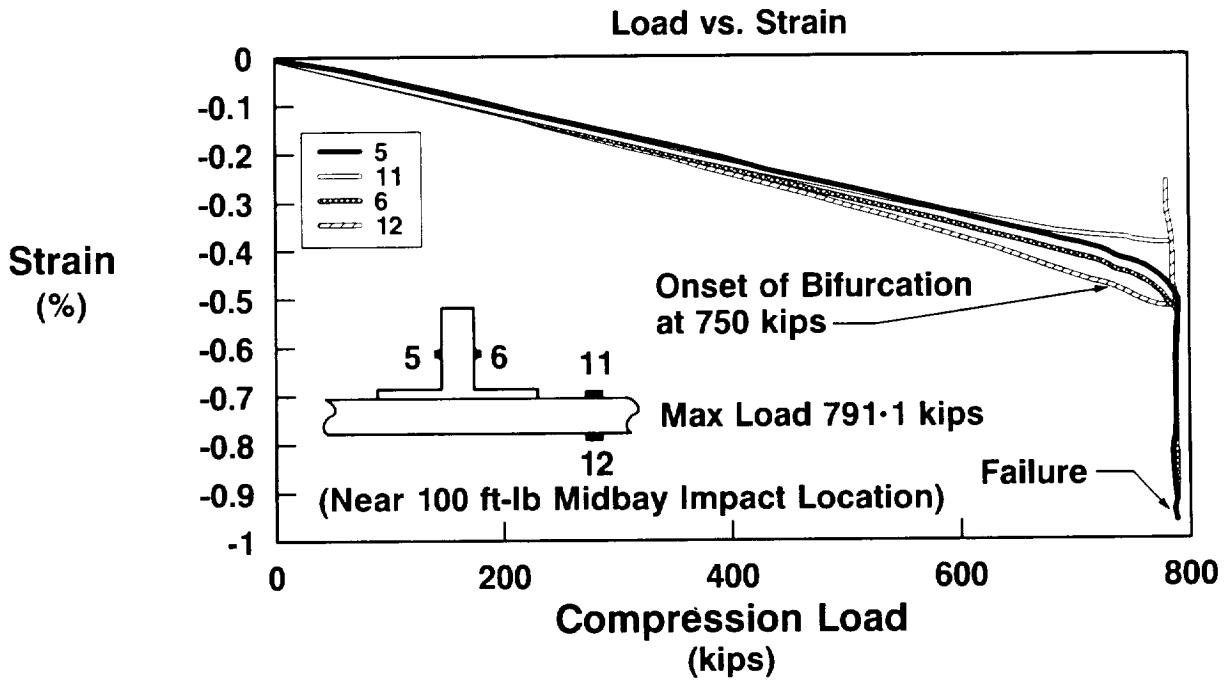

Figure 25. Six-stringer RTM wing compression panel test

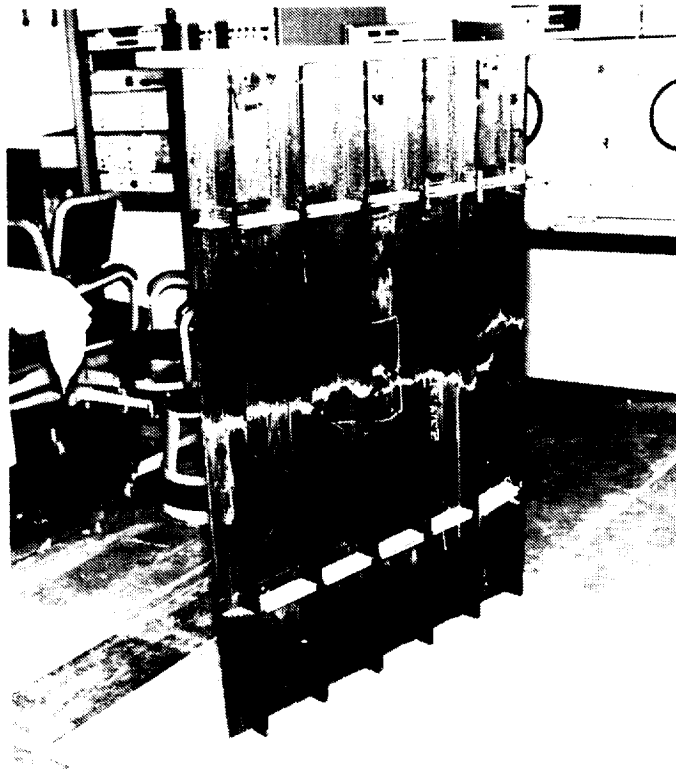

Figure 26. Six-Stringer RTM wing compression panel after the test (stringer side)



Figure 27. Six-stringer RTM wing compression panel after the test (skin side)

ORIGINAL FILED
BLACK AND WHITE PHOTOGRAPH

REPORT DOCUMENTATION PAGE

Form Approved
OMB No. 0704-0188

Public reporting burden for this collection of information is estimated to average 1 hour per response, including the time for reviewing instructions, searching existing data sources, gathering and maintaining the data needed, and completing and reviewing the collection of information. Send comments regarding this burden estimate or any other aspect of this collection of information, including suggestions for reducing this burden, to Washington Headquarters Services, Directorate for Information Operations and Reports, 1215 Jefferson Davis Highway, Suite 1204, Arlington, VA 22202-4302, and to the Office of Management and Budget, Paperwork Reduction Project (0704-0188), Washington, DC 20503.

1. AGENCY USE ONLY (Leave blank)		2. REPORT DATE January 1993	3. REPORT TYPE AND DATES COVERED Conference Publication	
4. TITLE AND SUBTITLE Third NASA Advanced Composites Technology Conference Volume I, Part 1			5. FUNDING NUMBERS 510-02-13-01	
6. AUTHOR(S) John G. Davis, Jr., and Herman L. Bohon (Compilers)				
7. PERFORMING ORGANIZATION NAME(S) AND ADDRESS(ES) NASA Langley Research Center Hampton, VA 23681-0001			8. PERFORMING ORGANIZATION REPORT NUMBER L-17167A	
9. SPONSORING/MONITORING AGENCY NAME(S) AND ADDRESS(ES) National Aeronautics and Space Administration Washington, DC 20546-0001 Department of Defense Washington, DC 20301			10. SPONSORING/MONITORING AGENCY REPORT NUMBER NASA CP-3178, Part 1	
11. SUPPLEMENTARY NOTES				
12a. DISTRIBUTION/AVAILABILITY STATEMENT Review for general release November 1994 Subject Category 24			12b. DISTRIBUTION CODE	
13. ABSTRACT (Maximum 200 words) This document is a compilation of papers presented at the Third NASA Advanced Composites Technology (ACT) Conference held at Long Beach, California, June 8-11, 1992. The ACT Program is a major multi-year research initiative to achieve a national goal of technology readiness before the end of the decade. Conference papers recorded results of research in the ACT Program in the specific areas of automated fiber placement, resin transfer molding, textile preforms, and stitching as these processes influence design, performance, and cost of composites in aircraft structures. Papers sponsored by the Department of Defense on the Design and Manufacturing of Low Cost Composites (DMLCC) are also included in Volume II of this document.				
14. SUBJECT TERMS Thermosets; Graphite fibers; Composite design; Stitching; Preforms; Manufacturing; Processing; Analysis			15. NUMBER OF PAGES 514	
			16. PRICE CODE A22	
17. SECURITY CLASSIFICATION OF REPORT Unclassified	18. SECURITY CLASSIFICATION OF THIS PAGE Unclassified	19. SECURITY CLASSIFICATION OF ABSTRACT Unclassified	20. LIMITATION OF ABSTRACT	

