

NASA Contractor Report 195079



# Investigation Into the Impact of Agility in Conceptual Fighter Design

R. M. Engelbeck  
*Boeing Defense & Space Group, Seattle, Washington*

(NASA-CR-195079) INVESTIGATION  
INTO THE IMPACT OF AGILITY ON  
CONCEPTUAL FIGHTER DESIGN (Boeing  
Defense and Space Group) 191 p

N96-10737

Unclas

G3/05 0063497

Contract NAS1-18762

June 1995

National Aeronautics and  
Space Administration  
Langley Research Center  
Hampton, Virginia 23681-0001

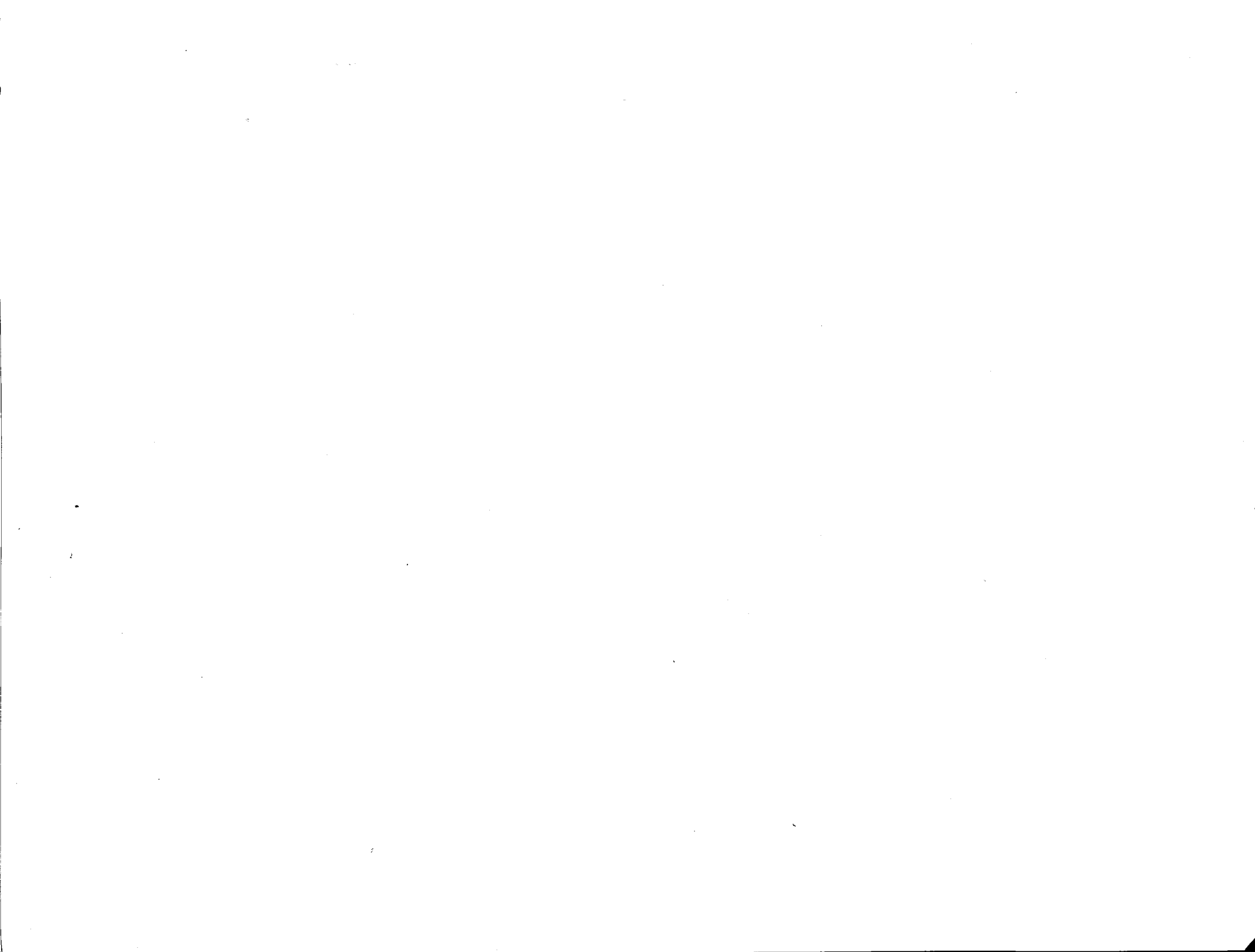

## **PREFACE**

The work reported here represents the final report for NASA Langley contract NAS1-18762 Spacecraft & Aircraft Guidance and Control Task 22, Agility Design Study.

The NASA Project Engineer was M. J. Logan, and the Boeing Principal Investigator was R. M. Engelbeck.

## ACKNOWLEDGMENTS

The authors would like to recognize the contributions made by all the people at Boeing who made this work possible:

- |                            |   |
|----------------------------|---|
| B. Ray                     | — Stability and Control Engineer<br>Helped break the conceptual design barrier                        |
| P. Gotlieb<br>G. Letsinger | — Stability and Control Engineer<br>— Stability and Control Engineer<br>Agility implementation issues |
| S. Bockmeyer               | — Aerodynamics Tech Aide<br>Graphic art and document publication                                      |
| D. Bock                    | — Aerodynamics Engineer<br>Sizing and Performance   |
| W. Mannick                 | — Weights Engineer<br>Weights and Technology Assessment   |
| W. Moore<br>D. Ruzicka     | — Configuration Engineer<br>— Configuration Engineer  |



## TABLE OF CONTENTS

1.0	Introduction and Summary .....	1
2.0	Study Requirements and Guidelines.....	6
2.1	Design Mission Profiles .....	6
	Air Interdiction Mission Description .....	6
	Air Superiority Mission Description.....	6
	Multi-Role Mission Description .....	6
2.2	Maneuver Performance Requirements.....	10
	Air Interdiction Maneuver Requirements .....	10
	Air Superiority and Multi-Role Maneuver Requirements.....	10
2.3	Agility Requirements.....	10
2.4	Observables Requirements.....	10
2.5	Carrier Suitability Requirements .....	10
3.0	Technology Risk Assessment.....	15
3.1	Technology Risk Assessment Approach.....	15
3.2	Technologies Used in Agility Study Configurations.....	37
3.3	Weight and Cost Impact of Advanced Technologies.....	37
4.0	Configuration Development.....	47
4.1	Assumptions and Groundrules .....	47
	Single Crew.....	47
	Twin Engine.....	47
	F-22 Core Avionics Suite .....	47
	Observables Features.....	49
	Control Effector Selection .....	50
4.2	Carrier Suitability Impact on Aircraft Designs .....	51
	Geometric Limitations .....	51
	Weight Limitations.....	51
	Landing Gear Design.....	51
	Wing and Fuselage Structural Reinforcement.....	51
4.3	Designing for Agility .....	55
	4.3.1 Agility Metrics.....	55
	4.3.2 Preliminary Design Guidelines .....	59
	4.3.3 Method Development.....	62
	4.3.3.1 Time to Bank and Capture - 90 Degree .....	62
	4.3.3.2 Longitudinal Control Requirements .....	64
	4.3.3.2.1 Minimum Nose Down Pitch Acceleration.....	66
	4.3.3.2.2 Maximum Trimmable Angle-of-Attack.....	67
	4.3.3.3 Maximum Lateral Side Force .....	67
	4.3.4 Configuration Evaluation .....	73
	4.3.4.1 Agility Impact on Low Observable Configurations.....	73
	4.3.4.2 Observables Impact of High Agility Design.....	73
	4.3.5 Summary .....	
5.0	Configuration Synthesis Results .....	82
5.1	Global Impact of Requirements on Design Space .....	82
5.2	Aircraft Synthesis Results .....	86
	5.2.1 Air-to-Ground Configurations.....	86
	5.2.2 Air-to-Air Configurations.....	89
	5.2.3 Multi-Role Configurations .....	89
	5.2.4 Joint Service Customer.....	97

6.0	Aircraft Design Data and Performance .....	102
6.1	Air Interdiction Concepts .....	102
6.2	Air Superiority Concepts .....	114
6.3	Multi-Role Concepts .....	139
7.0	Critical Assessment .....	163
8.0	Flight Research Needs Assessment .....	175

## LIST OF FIGURES

- 1.1 Fighter/Attack Aircraft Group - Metric Selection Results
- 1.2 Agility Design Study - Scope and Objectives
- 1.3 Agility Design Study Process
- 1.4 Agility Design Study Configurations
- 2.1 NASA (A/G) Design Mission - Battlefield Air Interdiction
- 2.2 NASA (A/A) Design Mission - Defensive Counter Air
- 2.3 Multi-Role Strike Mission
- 2.4 Air-to-Ground Energy/Maneuverability Requirements
- 2.5 Air-to-Air Energy/Maneuverability Requirements
- 2.6 Agility Design Goals
- 2.7 Carrier Suitability Requirements
- 3.1-1 Guidelines for Probability of Failure
- 3.1-2 Guidelines for Consequence of Failure
- 3.2 Technology Risk Assessment - Control Effectors
- 3.3 Technology Risk Assessment - Aerodynamics
- 3.4 Technology Risk Assessment - Propulsion
- 3.5 Technology Risk Assessment - Structures & Materials
- 3.6 Technology Risk Assessment - Avionics
- 3.7 Technology Risk Assessment - VMS Technologies
- 3.8 Technology Risk Assessment - Crew Systems
- 3.9 Technology Risk Assessment - Weapons
- 3.10 Sample Technology Risk Assessment Criteria
- 3.11 Risk Assessment
- 3.12 Technologies Selected - Control Effectors
- 3.13 Technologies Selected - Aerodynamics and Propulsion
- 3.14 Technologies Selected - Structures and Materials
- 3.15 Technologies Selected - Avionics and Vehicle Management Systems
- 3.16 Technologies Selected - Crew Systems and Weapons
- 3.17 Advanced Technology Applications - Weight and Cost Effects
- 3.18 Austere Avionics Suite for an Air-to-Air Agile Fighter
- 3.19 Austere Avionics Suite for a Multi-Role Agile Fighter
- 4.1 Configuration Evolution
- 4.2 Historical Weight Trends
- 4.3 Air-to-Air Agility Design Goals
- 4.4 Air-to-Ground Agility Design Goals
- 4.5 Wings Level Turning Options
- 4.6 Control Surface Deflections and Actuation Rates
- 4.7 Nominal Control Surface Size and Actuation Rates
- 4.8 Roll Agility Bank and Capture 90 degrees
- 4.9 Typical X-Chart
- 4.10 Normal Force Referenced to Plan View Gross Area
- 4.11 Center of Pressure Referenced to Plan View Gross Area
- 4.12 Side Force Control Effector Selection
- 4.13 Side Force Control Effector Effectiveness with Angle-of-Attack
- 4.14 Delta Wing Vortex Lattice Model
- 4.15 Delta Wing Aerodynamic Characteristics
- 4.16 Delta Side Force Control Concept
- 4.17 988-115 Vortex Lattice Model
- 4.18 988-115 Aerodynamic Characteristics
- 4.19 988-115 Control Effector Selection
- 4.20 Airplane Characteristics
- 5.1 Global Design Space; Twin Engine Air-to-Ground Deltoid; Takeoff Gross Weight (16)
- 5.2 Generic A/A Configuration; NASA Maneuver Requirements; T/W Required

## LIST OF FIGURES - continued

- 5.3 Aircraft Synthesis Approach
- 5.4 Air-to-Ground Configuration Sizing Charts
- 5.5 Important Design Parameters
- 5.6 Design Sensitivities About the Design Point
- 5.7 Aerodynamic Effect of Leading Edge Devices
- 5.8 Design Sensitivity to Fuel Load for Max Neg  $P_S$  Requirement
- 5.9 Air-to-Air, High Agility Configuration Sizing Chart
- 5.10 Air-to-Air, Medium Agility Configuration Sizing Chart
- 5.11 Multi-Role, High Agility Configuration Sizing Chart
- 5.12 Multi-Role, High Agility Configuration Sizing Chart
- 5.13 Multi-Role, Medium Agility Configuration Sizing Chart
- 5.14 Group Weight Breakdowns for USAF and Joint Service Aircraft - Full Mission Performance
- 5.15 Group Weight Breakdowns for USAF and Reduced Mission Performance Joint Service Aircraft
- 5.16 Carrier Suitability Assessment of Joint Service Designs
- 6.1 General Arrangement Drawing - 988-122
- 6.2 Inboard Profile - 988-122
- 6.3 Group Weight Statement - 988-122
- 6.4 C. G. Envelope - 988-122
- 6.5 Inertia Data at Combat Weight - 988-122
- 6.6 Aircraft Geometry - 988-122
- 6.7 Design Mission Segment Performance Breakdown - 988-122
- 6.8 Summary of Point Maneuver Performance - 988-122
- 6.9 General Arrangement Drawing - 988-123
- 6.10 Inboard Profile - 988-123
- 6.11 Group Weight Statement - 988-123
- 6.12 C. G. Envelope - 988-123
- 6.13 Inertia Data at Combat Weight - 988-123
- 6.14 Aircraft Geometry - 988-123
- 6.15 Design Mission Segment Performance Breakdown - 988-123
- 6.16 Summary of Point Maneuver Performance - 988-123
- 6.17 General Arrangement Drawing - 988-119
- 6.18 Inboard Profile - 988-119
- 6.19 Group Weight Statement - 988-119
- 6.20 C. G. Envelope - 988-119
- 6.21 Inertia Data at Combat Weight - 988-119
- 6.22 Aircraft Geometry - 988-119
- 6.23 Design Mission Segment Performance Breakdown - 988-119
- 6.24 Summary of Point Maneuver Performance - 988-119
- 6.25 General Arrangement Drawing - 988-118
- 6.26 Inboard Profile - 988-118
- 6.27 Group Weight Statement - 988-118
- 6.28 C. G. Envelope - 988-118
- 6.29 Inertia Data at Combat Weight - 988-118
- 6.30 Aircraft Geometry - 988-118
- 6.31 Design Mission Segment Performance Breakdown - 988-118
- 6.32 Summary of Point Maneuver Performance - 988-118
- 6.33 General Arrangement Drawing - 988-115
- 6.34 Inboard Profile - 988-115
- 6.35 Group Weight Statement - 988-115
- 6.36 C. G. Envelope - 988-115
- 6.37 Inertia Data at Combat Weight - 988-115
- 6.38 Aircraft Geometry - 988-115

**LIST OF FIGURES - continued**

- 6.39 Design Mission Segment Performance Breakdown - 988-115
- 6.40 Summary of Point Maneuver Performance - 988-115
- 6.41 General Arrangement Drawing - 988-114
- 6.42 Inboard Profile - 988-114
- 6.43 Group Weight Statement - 988-114
- 6.44 C. G. Envelope - 988-114
- 6.45 Inertia Data at Combat Weight - 988-114
- 6.46 Aircraft Geometry - 988-114
- 6.47 Design Mission Segment Performance Breakdown - 988-114
- 6.48 Summary of Point Maneuver Performance - 988-114



## 1.0 Introduction and Summary

The work contained in this report was accomplished as part of the NASA Langley Research Center (LaRC) Agility Design Study Activity. The purpose of the NASA Agility Design Study is to assess the impact of specific agility requirements on the aircraft design decisions.

Previous work leading up to this phase of the study provided a set of agility metrics to be used to categorize aircraft agility and the methodology to assess these metrics. These metrics are identified in figure 1.1.

The purpose of the current phase of study is to conduct configuration design studies to determine the impact of varying levels of agility requirements on a wide spectrum of potential aircraft and missions. Lockheed has investigated the impact of agility requirements on an existing airframe in the fulfillment of a multirole fighter mission. McDonnell-Douglas has investigated new designs in the fulfillment of the same multi-role fighter mission. This contract report addresses the effects of customer requirements (NAVY Vs Air Force) and aircraft mission role (Air Superiority, Multi-Role, and Air Interdiction) on agility design decisions. The study process is presented in figure 1.3.

The requirements for the aircraft designs are presented in section 2.0. The concepts presented here are intended to be representative of high end, next-generation replacements to the A-6 Air Interdiction and F-15/F-14 Air Superiority aircraft. The Multi-Role concepts represent a compromise design between the dedicated Air-Superiority designs and the dedicated Air-Interdiction designs. In addition to mission role, the impact of customer requirements (primarily carrier suitability) and observably levels were used to develop the matrix of configurations studied and presented in figure 1.4.

A technology risk assessment was accomplished using a list of suggested technologies supplied by NASA as a point of departure. The results of the risk assessment presented in section 3.0 were then used as the basis of selecting subsystems and technologies available for use in the development of the individual configurations studied.

Several of the technologies on the NASA supplied list were in reality a configuration concept dependent list of control effectors. As part of the configuration design trade studies presented in section 4.0, a selected subset of control effectors identified for use on each of four basic configuration types. Control sizing studies were conducted to determine the most effective combination of control effectors required to meet all the agility design requirements. The methodology used and results are presented in detail for use as design guidelines in selecting individual control effectors, or combinations of control effectors, necessary to achieve an agility level for a given application.

Twelve configurations were studied under this contract, six Air Force aircraft and their six derivative joint service counterparts. Trade studies documented in section 5.0 were conducted to identify the important design parameters and driving design constraints. These constraints were then used in the selection of the design points.

Once each individual design point was selected, three-view drawings and interior layouts were finalized. Group Weight statements, Center-of-gravity envelopes, Inertia estimates, drag polars, maneuver point performance and mission breakdowns were also finalized and presented in section 6.0

The results of a critical assessment are presented in section 7.0.

Section 8.0 contains recommendations for flight research.

## Fighter/Attack Aircraft Group Metric Selection Results

**BOEING**

- Working group consensus
  - Government inputs: NASA, AF
  - Industry inputs: Boeing, Eidetics, General Dynamics, McDonnell-Douglas
  
- Metrics Selected:

Metric	Conditions
1. Maximum negative Ps	0.6M @ 15,000 ft., max inst. $\psi$ 450 kts @ sea level, max inst. $\psi$
2. Time-to-bank 90°	0.6M @ 15,000 ft, max inst. Nz 450 kts @ sea level, 5g
3. Minimum nose-down pitch acceleration	Condition for Cm*
4. Maximum achievable, trimmed angle-of-attack	Subsonic
5. Maximum lateral acceleration	Max inst. Nz (air-to-air) 1g wings level (air-to-ground)

Figure 1.1



# Agility Design Study Scope and Objectives

**BOEING**

## Purpose

- Investigate impact of agility on design decisions
- Identify NASA research needs
- Develop agility design guidelines

## Objectives:

- Design 12 configurations to address the issues of:
  - USAF vs Joint Service customers
  - Aircraft Mission Role
  - LO vs Agility

Mission	Air Force Only		Joint Service	
	Medium Agility	High Agility	Medium Agility	High Agility
Air Superiority	Low Observables	Moderate Observables	Low Observables	Moderate Observables
Multi-Role	Low Observables	Moderate Observables	Low Observables	Moderate Observables
Air Interdiction	Low Observables	Low Observables	Low Observables	Low Observables

Figure 1.2

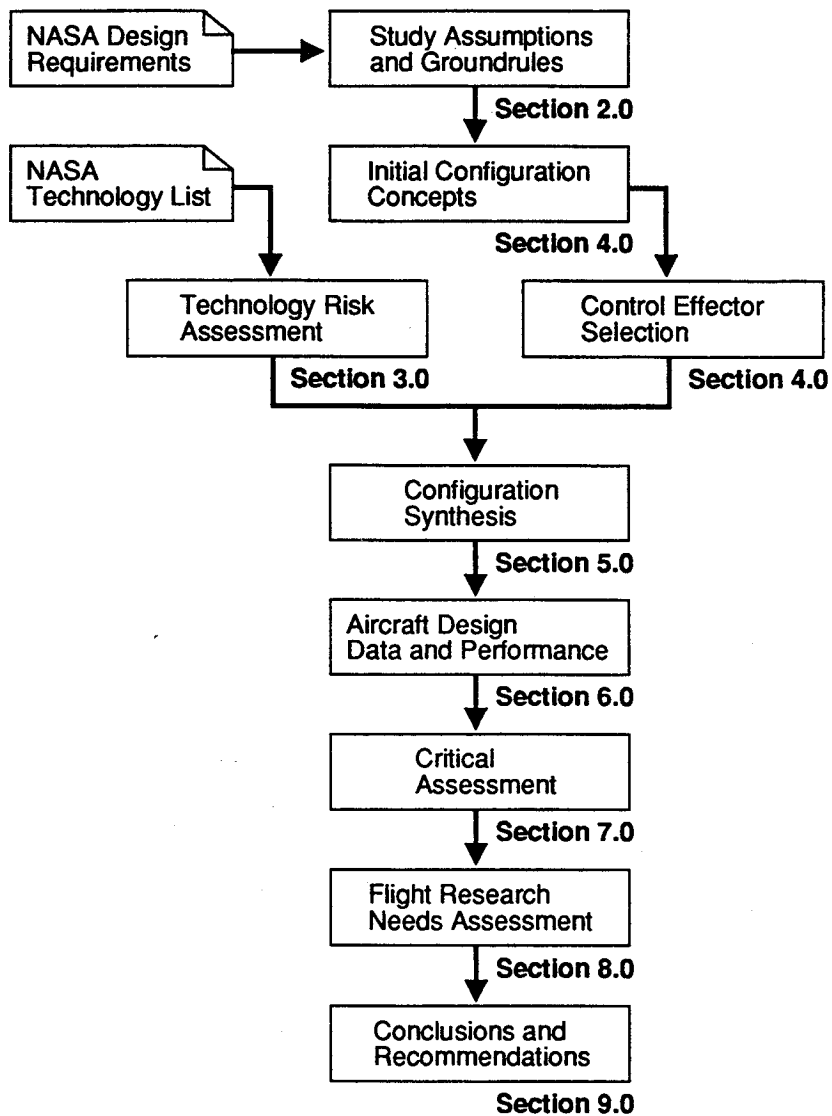
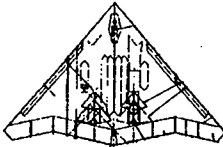
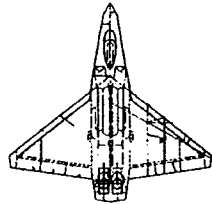
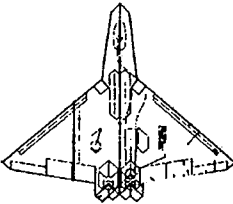
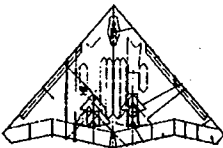
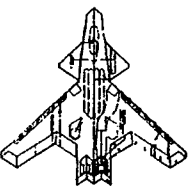
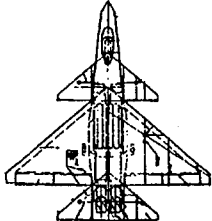

Figure 1.3. Agility Design Study Process

		Air-to-ground		Multi-role		Air-to-air	
		Low observables	Moderate observables	Low observables	Moderate observables	Low observables	Moderate observables
Agility	Moderate	 988-122	X	 988-118	X	 988-114	X
	High	 988-123	X	X	 988-119	X	 988-115

**USAF Customer**

**Joint Service**

Figure 1.4. Agility Design Study Configurations

## **2.0 Study Requirements and Guidelines**

### **2.1 Design Mission Profiles**

#### **Air Interdiction Mission Description**

The Battlefield Air Interdiction Mission defined by NASA is a 1000 Nm High-Lo-Lo-High profile presented in figure 2.1. The design payload consists of four GBU-27 laser guided bombs and two AIM-9 missiles for self defence. The intent of the mission is to describe a reasonable interdiction range/payload. NASA continded that a significant air power deficiency was discovered during Desert Storm in that mission ranges were limited to about 600 Nm total radius, virtually all of which was flown at moderate altitudes. Those missions which necessitated low-altitude attacks (eg. Tornado airfield attacks, F-16 Interdiction) required numerous aircraft since fuel tanks were the majority of the store loadings. The Navy A-6E is currently capable of 450/300 Nm leg distances using the J52 engine with an external payload similar to that called out here. To accomplish this the A-6 does carry a centerline 300 gallon fuel tank. NASA expects an F404 engined A-6 would probably be able to accomplish the mission described.

Takeoff fuel allowance is modeled by 20 minutes at idle power and 2 minutes at maximum augmented power. Both the inbound and outbound high altitude cruise legs are at optimum Cruise Mach number and altitude, with a radius of 600 Nm. The ingress leg is 500 KTAS at 200 feet altitude for 400 Nm. The combat leg over the target consists of four sustained turns at Mach 0.8 at Military Power setting. All four GBU-27s are expended along with 500 rounds of 30 mm ammo. The egress from the target area is accomplished at 550 KTAS at 200 feet altitude for the same 400 Nm radius as the ingress.

#### **Air Superiority Mission Description**

The design mission for the dedicated air superiority concepts to replace the F-14 and F-15 is the Defensive Counter Air (DCA) mission presented in figure 2.2. This mission has a total radius of 450 Nm with a payload of four AIM-120 missiles, two AIM-9 missiles and 500 rounds of ammo. Takeoff fuel allowance is modeled by 20 minutes at sea level and idle power followed by 2 minutes at maximum afterburner. The outbound leg to the aircraft combat station consists of a 350Nm cruise leg accomplished at best cruise altitude and Mach number followed by a 90 minute loiter on station at Mach 0.8 at 40000 feet. The stationkeeping is followed by a 1.5 Mach dash (dry power) to intercept inbound adversaries. Combat is modeled by four sustained turns at 40000 feet, Mach 0.9 at maximum augmented thrust with the expenditure of four AIM-120 missiles and 50% of the ammunition. After the combat segment, a military power climb is executed for the 450 Nm inbound cruise at optimum Mach number and altitude. The aircraft lands with reserves of 5% mission fuel at its point of origin after a 20 minute loiter at sea level and optimum Mach number.

#### **Multi-Role Mission Description**

The multi-role mission presented in figure 2.3 is a compromise between the rigorous radius requirements of the air interdiction design mission radius and payload. The design weapons load is two 2000 lb JDAM laser guided bombs. This payload was reduced from that of the air interdiction mission discussed because the two advanced laser guided weapons would not suffer unacceptably in Pk relative to the four GBU-27s carried in the air interdiction mission. Combat maneuver performance of the air superiority design is maintained. The takeoff allowance was reduced to ten minutes at idle power, 15 seconds in intermediate power, and 15 seconds in maximum afterburner. After takeoff a military power climb is initiated until the aircraft reaches its optimum cruise altitude. The outbound cruise leg is 650 Nm at optimum cruise Mach number. The aircraft then drops to a penetration altitude of 20,000 feet to ingress to the target at 540 KTAS for 50 Nm. The 700 Nm total mission radius of the multi-role strike mission still exceeds the 600 Nm mile limitation presented in the air interdiction mission discussion, without the use of external tanks. Over the target, the aircraft drops its air-to-ground weapons load of two JDAM laser guided bombs. Combat over the target is modeled by a 180 degree sustained turn at 540 KTAS at 20000 feet using dry power. The aircraft 50 Nm egress from the target area is accomplished at 540KTAS and 20000 feet. At this point the aircraft enters an air engagement modeled by a 360 degree turn at 540 KTAS and 20000 feet using maximum dry power.

# NASA (A/G) Design Mission - Battlefield Air Interdiction (4) GBU-27 + (2) AIM-9 + 1000rd 30mm

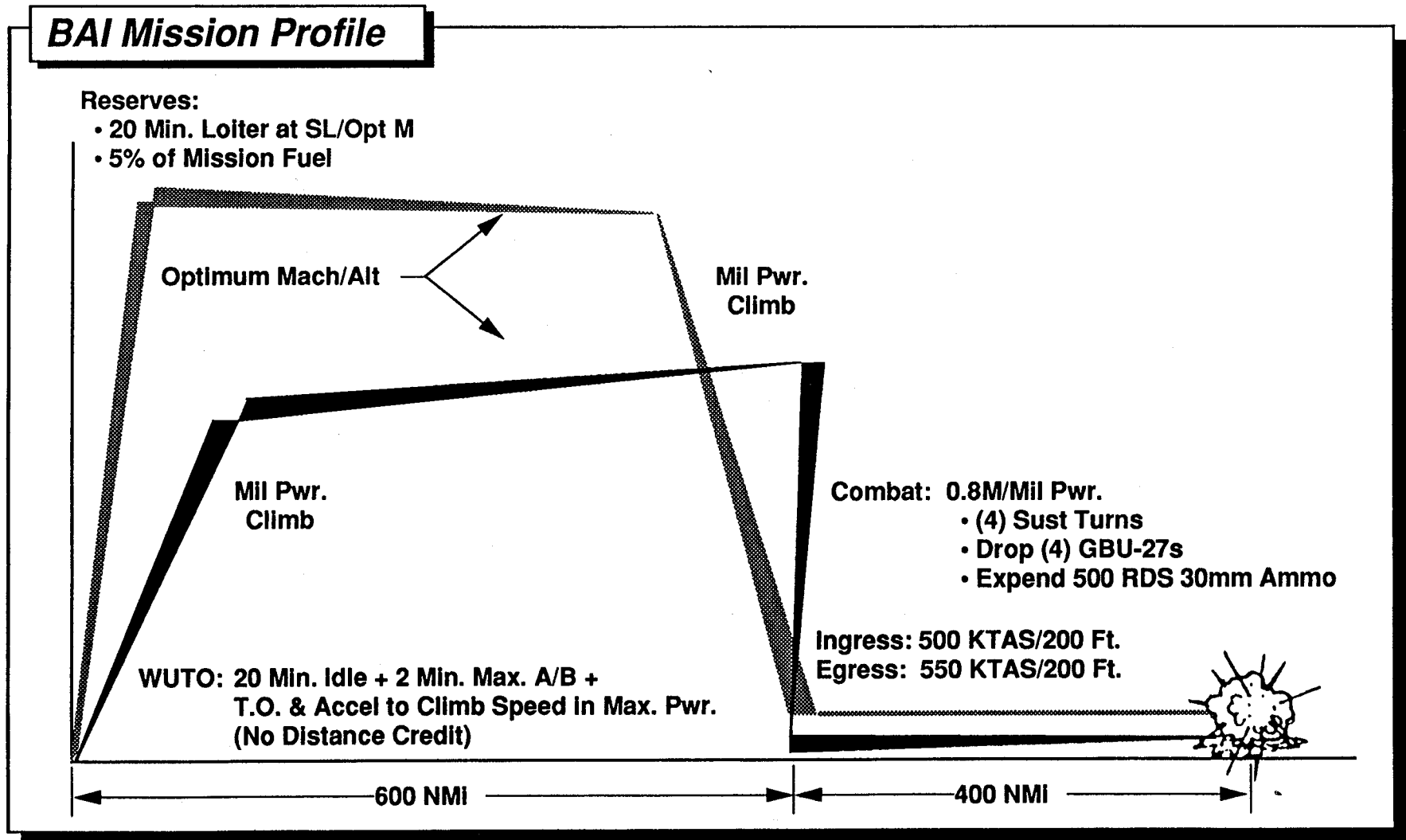

Figure 2.1

# NASA (A/A) Design Mission - Defensive Counter Air (2) AIM-9 + (4) AIM-120

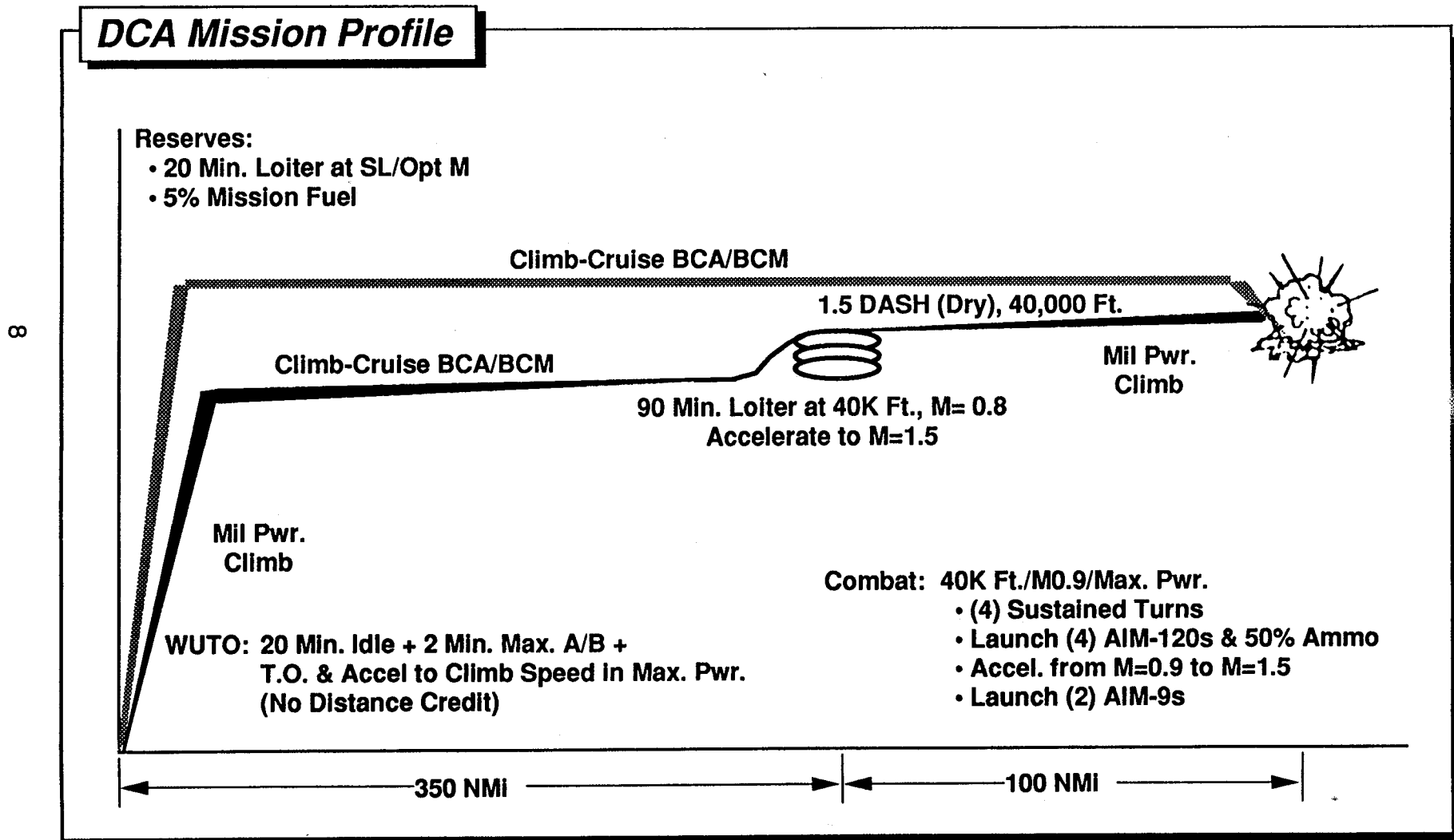

Figure 2.2

# Multi-Role Strike Mission

- Reserves:**
- 20 Min. Loiter at S.L./Opt. M
  - 5% of Mission Fuel

- Weapons:**
- (2) JDAM - 2,000 lb
  - (2) AIM - 120
  - 400 RDS Ammo 20 mm

6

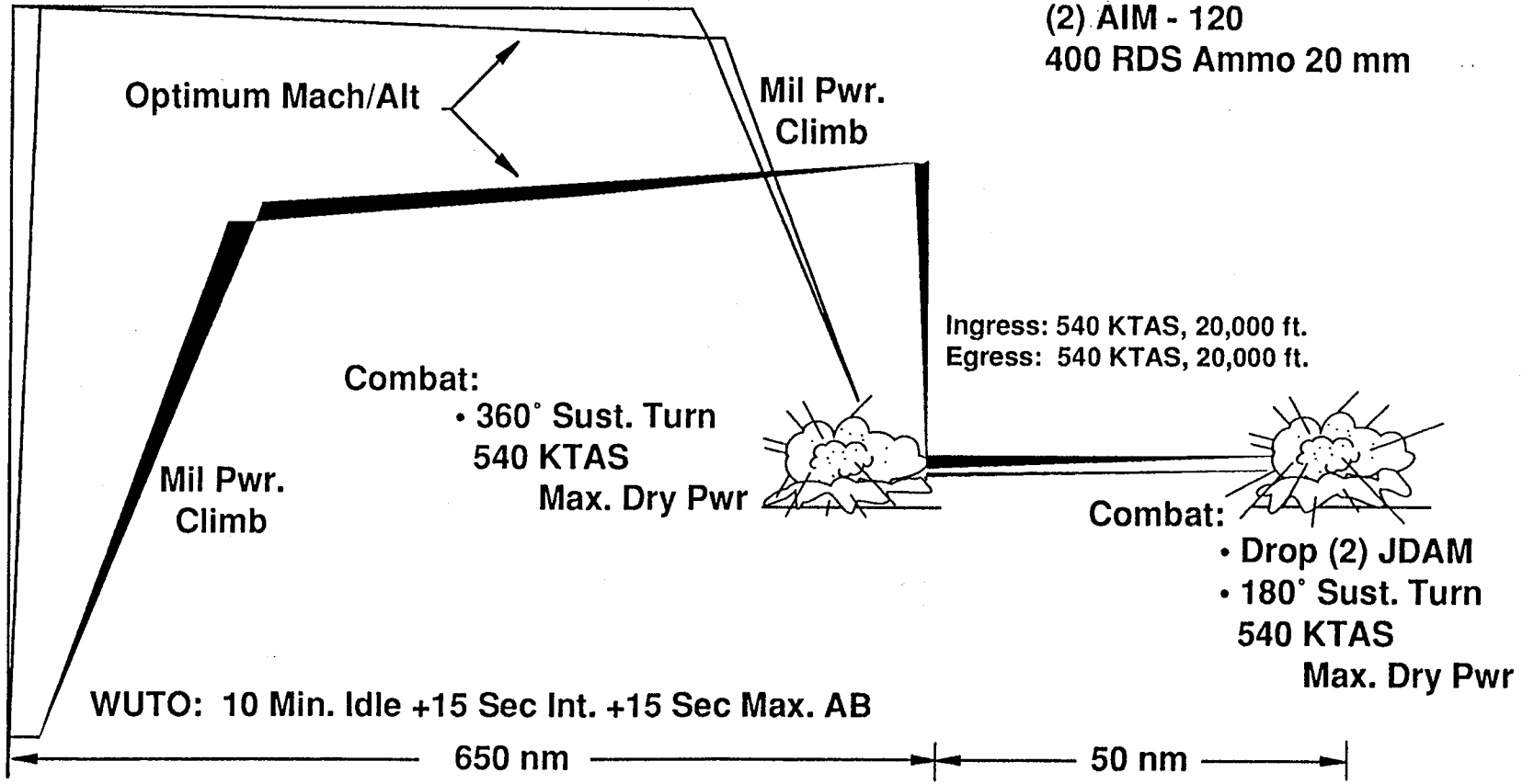

Figure 2.3.

The aircraft escapes the engagement and executes a military power climb to optimum cruise altitude. The aircraft then returns to its base 650 Nm away. Reserves are specified as 20 minutes loiter at sea level at optimum Mach number plus 5% of mission fuel.

## 2.2 Maneuver Performance Requirements

### Air Interdiction Maneuver Requirements

The maneuver requirements for the air interdiction and multi-role designs is presented in figure 2.4.

### Air Superiority and Multi-Role Maneuver Requirements

The NASA defined Air-Superiority Maneuver Requirements are intended to be approximately 10% better than the F-14 and F-15 maneuver capabilities. There are 25 maneuver conditions called out in figure 2.5. The multi-role designs meet the same maneuver requirements as the air-superiority designs.

## 2.3 Agility Requirements

There five agility design metrics presented in figure 2.6 along with goals for aircraft designed for the Air Interdiction (AG) and Air Superiority (AA). The Multirole concepts are designed to the same agility requirements as the Air Superiority concepts.

## 2.4 Observables Requirements

The purpose of this study is not to develop low observables technology, but rather to assess agility requirements impact on aircraft with varying degrees of stealth characteristics. This purpose and the sensitive nature of observables technology lead to the establishment of the observables requirements used in this study. For the purposes of this study, low observables is defined as a level of observables consistent with the B-2, and moderate observables is defined as a level of observables consistent with the F-22. No actual observables assessment will be conducted on the designs or reported. Observables are addressed purely as a qualitative measure and implemented by the designers to be consistent with the requirements and their experience.

## 2.5 Carrier Suitability Requirements

The joint service concepts must meet the carrier suitability requirements presented in figure 2.7 in addition to all the requirements met by their counterpart Air Force concepts. The catapult wind-over-deck required with the aircraft at its design gross weight is zero knots on a C13-1 catapult. The single engine rate-of-climb after launch on a tropical day is 200 feet/minute. There is no specified arrested wind-over-deck requirement, but the single engine rate-of-climb after an aborted approach is 500 feet/minute. The desired carrier deck spotting factor is 1.0 relative to the F-18, not to exceed 1.31.



## Air-to-Ground Energy / Maneuverability Requirements

---

	<u>Requirement</u>
Combat Ceiling .....	40,000 ft
Accelerate From 300 Kts to 550 Kts (Sea Level) .....	60 sec
Sustained Load Factor (Sea Level, Mach = 0.8) .....	6.5 g's*
Instantaneous Load Factor .....	9.0 g's
Unrefueled Ferry Range .....	3,000 nmi

\* With Stores and 60% Fuel

Figure 2.4

## Air-to-Air Energy / Maneuverability Requirements

Mach	Altitude (Kft)	Sustained g's	Instantaneous g's	Excess Power - Ps (fps)
0.6	0			900
0.9	0			1,300
0.6	10	6.0	8.0	650
0.9	10	9.0*		1,000
1.2	10			600
0.6	20	4.4		450
0.9	20	7.0	9.0*	800
1.2	20	6.8		650
1.4	20			600
0.9	30	5.0	9.0*	550
1.2	30	5.0	9.0*	500
1.4	30			600

- Acceleration Time from Mach = 0.9 to 1.5: <60 sec. at 40,000 ft.
- Combat Ceiling: >55,000 ft.
- Unrefueled Ferry Range: >3,000 nmi with AIM-9 / 20mm Stores Retained

\* Structural Limit

Figure 2.5

## Fighter / Attack Aircraft Group Agility Design Goals

Metric	Conditions	Low	Medium	High
1. Maximum Negative $P_s$	A-A: Mach = 0.6, 15 Kft ( $N_z = 5.5g$ )	-800 ft/sec	-450 ft/sec	-100 ft/sec
	A-G: 450 Kts Sea Level ( $N_z = 7.5g$ )	(Same)	(Same)	(Same)
2. Time-to-Bank and Capture 90°	A-A: Mach = 0.6, 15 Kft, Maximum Instantaneous $N_z = 9.0$	3.0 sec	2.5 sec	1.5 sec
	A-G: 450 Kts Sea Level, 5g	2.0 sec	1.5 sec	1.0 sec
3. Minimum Nose-Down Pitch Acceleration	A-A: Condition for $C_m^*$ Use Mach = 0.6, 15 Kft for Consistency	-0.05 rad/sec <sup>2</sup>	-0.15 rad/sec <sup>2</sup>	-0.35 rad/sec <sup>2</sup>
	A-G: Same	(Same)	(Same)	(Same)
4. Maximum Achievable Departure-Free Angle-of-Attack	With Air-to-Air Stores, Subsonic	25 deg	40 deg	70 deg
5. Maximum Lateral Acceleration	A-A: Mach = 0.6, 15 Kft, Maximum Instantaneous $N_z = 9.0$	0.25 g	0.4 g	1.0 g
	A-G: 450 Kts Sea Level, Wings Level	0.6 g	1.2 g	2.0 g

Figure 2.6

# Carrier Suitability Requirements

---

## Requirement

### **Catapult (C13-1)**

- WOD Requirement at Design Gross Weight ..... 0 Kts
- Single Engine Out Rate-of-Climb ..... 200 ft/min

### **Arrest (Mk.7 Mod 2)**

- WOD Requirement at Design Landing Weight ..... None
- Single Engine Out Rate-of-Climb ..... 500 ft/min

### **Spotting Factor**

- Desired ..... 1.00
- Required ..... 1.31

Figure 2.7

### **3.0 Technology Risk Assessment**

The objective of the technology assessment task was to identify the technologies that provide the greatest benefit for the twelve candidate Agility Design Study (ADS) concepts and also to help NASA identify meaningful research needs which, if accomplished, will improve future aircraft design, manufacturing and performance.

#### **3.1 Technology Risk Assessment Approach**

A "technology matrix" was developed by the Boeing Military Airplanes (BMA) technology staff using the technology list provided by NASA with additions and combinations as deemed necessary to best identify the technologies that might be configuration drivers or, required to satisfy the ADS mission performance criteria. The basic ground rules used by the technical assessment experts were that the IOC date would be 2005 and development testing (materials, systems, aerodynamics, etc.) would be accomplished. The technology assessors were also required to:

- (1) Provide a brief description of the individual technology.
- (2) Provide a rationale for determining whether the technology should or should not be selected for incorporation into ADS configurations.
- (3) Provide the expected impact, either beneficial or detrimental, the technology would have on the configurations if incorporated into the design.
- (4) Provide a subjective assessment of the probability and consequence of failure as determined by the ground rules shown in Tables 3.1-- 1 and 3.1-2 and described in Section 3.1.1.
- (5) Provide a suggestion of research needed to bring the technology to maturity and validation.

The resulting "technology matrix" is shown in figure 3.1-3 through figure 3.1-16.

#### **Probability and Consequence of Failure Determination**

Each technology was rated in terms of Probability of Failure (POF) and Consequence of Failure (COF) as outlined by the guidelines specified in figure 3.1- 1 and 3.1-2. The technology assessment used POF as the probability that the identified technology will or will not be available for aircraft application at the IOC date specified. Likewise, COF is the consequence to the aircraft if the identified technology is not available for application. Using the Probability of Failure guidelines, each proposed technology has been considered with respect to its maturity, complexity and level of support base. In assessing the Consequence of Failure, each technology has been considered with respect to aircraft performance, cost and schedule impacts. The POF and COF values shown in the tables were only to be considered as guidelines and not absolutes. All technology assessors subjectively determined POF and COF risk levels for each proposed technology implication based on the imposed guidelines. These guidelines are a combination of Boeing and Defense Systems Management College (DSMC) criteria for determining risk.

The standard risk plot of POF vs COF which was used by the technical experts to assess the risk level of each proposed technology is shown in figure 3.1- 17. On the plot are lines that represent what Boeing Military Airplanes (BMA) believes are acceptable limits of POF and COF going into a Demonstration/Validation (DEM/VAL) phase and a full Scale Development (FSD) phase of an aircraft development cycle. Acceptable values of POF and COF for entering the DEM/VAL phase are less than or equal to 0.5. Acceptable values for entering the FSD phase are less than or equal to 0.3.

Each proposed technology's POF and COF were plotted and are shown in figures 3.1- 18 through 3.1- 22. All the technologies are identified by a number on the plots for quick reference. The technologies which were selected to be used in the evaluations of the ADS "point design" configurations are shown as shaded areas in the tabulations on the left of each figure. Examining the risk plots and considering the acceptable values as defined for DAM/VAL and FSD, the technologies that require the most attention can be identified and earmarked for future meaningful research activities.

Value	Maturity of hardware/software	Complexity of hardware/software	Support base
0.1	Existing equipment; in production	Simple	Multiple programs and services
0.3	Minor redesign, prototype/ engineering model flight tested; extensive lab demonstrations	Somewhat complex	Multiple programs
0.5	Major change feasible, preliminary brassboard	Fairly complex	Several parallel programs
0.7	Proof of concept in lab environment, complex hardware design, new software similar to existing	Very complex	At least one other program
0.9	Concept formulation, some research, never done before	Extremely complex	No additional programs

*Figure 3.1-1. Guidelines for Probability of Failure*

Value	Fall back solutions	Cost factor	Schedule factor	Downtime factor
0.1	Several acceptable alternatives	Highly confident will reduce LCC	90-100% confident will meet IOC	Highly confident will reduce downtime significantly
0.3	A few known alternatives	Fairly confident will reduce LCC	75-90% confident will meet IOC	Fairly confident will reduce downtime significantly
0.5	A single acceptable alternative	LCC will not change much	50-75% confident will meet IOC	Highly confident will reduce downtime somewhat
0.7	Some possible alternatives	Fairly confident will increase LCC	25-50% confident will meet IOC	Fairly confident will reduce downtime somewhat
0.9	No acceptable alternative	Highly confident will increase LCC	0-25% confident will meet IOC	Downtime may not be reduced much

*Figure 3.1-2. Guidelines for Consequence of Failure*

### Control Effectors

Technology description	Selection rationale	← Configuration Impact →		Probability of failure	Consequence of failure	Recommended research
		Benefit	Penalty			
Conventional Ailerons	Roll performance at high AOA better than spoilers	Effective to high AOA		.10	.10	
Tiperons			Heavy attack pivot req'd.	.60	.30	Wind tunnel test database needed to quantify benefits
Trailing Edge Maneuver Flaps	Proven	Increased maneuverability	Weight	.01	.01	Wind tunnel database needed for flexible control concepts
Leading Edge Flaps or Slats	Increased high lift capability	Low takeoff & approach speeds	Increased IUT and complexity	.10	.10	Share LE slat effectiveness
Blown Control Devices	Use to reduce control surf size or to increase control power	Significant increase in effectiveness	Ineffective at high speed	.40	.60	
Porous Leading/Trailing Edge Devices	May provide increased high lift with low RCS & reduced complexity compared to slats/slotted flaps	Low RCS, reduced mechanical complexity	Unproven concept	.70	.70	More wind tunnel test data needed to prove concept
Leading Edge Suction/Blowing	Increased high lift	Lower T.O. & appr. speed	Complexity	.50	.30	More wind tunnel test data needed to prove concept
Tangential Wing Blowing	Provides high lift with less complexity	Simpler system than slot blowing	Ineffective at high speed	.70	.70	Wind tunnel test database needed to quantify benefits vs. blowing requirements
Drag rudders	Provide yaw control with no vertical fins	Low RCS	Reduced effectiveness	.40	.30	Wind tunnel database needed as a function of deflection and wing planform
Spoilers/Speedbrakes	Wing spoilers very effective ahead of high lift flaps	Low AOA effectiveness	Weight, poor high AOA effectiveness	.10	.50	

Figure 3.1-3.

### Control Effectors (continued)

Technology description	Selection rationale	← Configuration Impact →		Probability of failure	Consequence of failure	Recommended research
		Benefit	Penalty			
Horizontal Tail With Elevator	This type of control is only appropriate for subsonic airplanes	May be somewhat lighter than all-moving horiz. tail	Poor effectiveness at supersonic speed	.10	.30	
All-Moving Horizontal Tail	High speed, high agility airplanes need high pitch control power	Good effectiveness throughout speed range	Requires high horsepower hydraulic system	.10	.30	
Variable Incidence Wing	This is an option if the high speed design of the airplane results in unacceptable over-the-nose visibility	Provides good over-the-nose visibility	Weight	.30	.70	
Vertical Tail With Rudder	Standard low risk approach to yaw control/directional stability	Proven effective	Weight	.10	.30	
All-Moving Canard	Provides both pitch and yaw control if positioned properly	Proven effective	RCS, poor pilot visibility	.20	.60	
Other Moving Fin(s) or Yaw Vanes	Better control at supersonic speed than fin with rudder	Good high AOA effectiveness	Weight	.10	.30	
Double Hinged/Split Control Devices	Provide more control power than single hinge. May result in reduced fin size.	Increased yaw control	Weight	.10	.10	
Articulating Forebody Strakes	May provide high AOA yaw control to supplement rudders	High AOA yaw control	Increased RCS	.70	.60	Develop wind tunnel data base of effectiveness on chined forebodies
Articulating Chine	May provide high AOA yaw control to supplement rudders	High AOA yaw control	Weight, complexity	.65	.65	Wind tunnel research needed to quantify effectiveness for various forebody shapes

Figure 3.1-4.



### Control Effectors (concluded)

Technology description	Selection rationale	← Configuration Impact →		Probability of failure	Consequence of failure	Recommended research
		Benefit	Penalty			
Forebody Jet Blowing	May provide high AOA yaw control to supplement rudders	High AOA yaw control	Weight, complexity	.70	.60	Wind tunnel research needed to quantify effectiveness for various forebody shapes
Forebody Slot Blowing	May provide high AOA yaw control to supplement rudders	High AOA yaw control	Weight, complexity	.70	.60	Wind tunnel research needed to quantify effectiveness for various forebody shapes
Forebody Suction	May provide high AOA yaw control to supplement rudders	High AOA yaw control	Weight, complexity	.70	.60	Wind tunnel research needed to quantify effectiveness for various forebody shapes
Articulating Nose Strakes	May provide high AOA yaw control to supplement rudders	High AOA yaw control	Weight, complexity	.60	.60	Wind tunnel research needed to quantify effectiveness for various forebody shapes
Body Flaps	Pitch control due to body flap may allow smaller horizontal tail	High AOA pitch control	Weight	.50	.30	
Fluidic Thrust Vectoring	Provide increased yaw control	Low RCS	Complex	.70	.70	Continue to develop to attain increased vectoring capability
Pitch Axis Mechanical Thrust Vectoring	Low risk approach to increased pitch control power	Increased maneuverability	Weight	.30	.20	
Multi-Axis Mechanical Thrust Vectoring	Low risk approach to increased combined pitch and yaw control power	Increased maneuverability	Weight	.40	.30	

Figure 3.1-5.

## Aerodynamics

Technology description	Selection rationale	Configuration Impact		Probability of failure	Consequence of failure	Recommended research
		Benefit	Penalty			
Vortex Flap	Improved cruise & maneuver L/D	10-20% L/D improvement (better on high- $\Lambda$ wings)	<ul style="list-style-type: none"> <li>Higher wing weight</li> <li>Signature penalty</li> </ul>	.30	.20	Wind tunnel testing for sharp & semi-sharp leading edges, with various $\Lambda_{LE}$
Variable Camber/Mission Adaptive Wing	Improved L/D over entire operating envelope	10-40% L/D improvement, depending on mission profile	Wing weight & complexity increased	<ul style="list-style-type: none"> <li>.30 for LE/TE</li> <li>.70 for full chord</li> </ul>	.30	<ul style="list-style-type: none"> <li>CFD &amp; wind tunnel tests of variable geometry – LE/TE vs. full chord</li> <li>Structural concepts for full chord system</li> </ul>
Natural Flow Wing	Improved cruise L/D	10% L/D increase in some cases	Potential curvature/manufacturing problems	.30	.30	CFD & wind tunnel tests of new technology applied to realistic configurations
Porous Lifting Surface Technology	Reduce shock strength	10% increase in Mach capability	<ul style="list-style-type: none"> <li>Potential drag penalty</li> <li>Surface complexity</li> <li>Maintainability</li> </ul>	.60	.40	<ul style="list-style-type: none"> <li>Flight test samples</li> <li>Detailed CFD &amp; wind tunnel shock strength vs. drag trade</li> </ul>
Natural Laminar Flow/Supercritical Wing	Reduce cruise drag	10-20% drag reduction	Potential to increase manufacturing cost	.20	.30	Improve CFD capability for transition prediction
Hybrid Laminar Flow System	Reduce cruise drag, $\uparrow$ L/D	10-40% drag reduction	Increased weight & complexity	.40	.30	<ul style="list-style-type: none"> <li>Improve CFD transition prediction</li> <li>Wind tunnel &amp; flight testing of options</li> </ul>
Forward Sweep Wing Technology	Improved stall characteristics & high- $\alpha$ aero performance	<ul style="list-style-type: none"> <li>Higher sustainable angle-of-attack</li> <li>Improved high-<math>\alpha</math> maneuver</li> </ul>	Increased structural weight	.40	.50	<ul style="list-style-type: none"> <li>CFD &amp; wind tunnel &amp; flight tests on configurations of interest in addition to X-29</li> <li>Aero-structural optimization</li> </ul>

Figure 3.1-6.

## Propulsion

Technology description	Selection rationale	← Configuration Impact →		Probability of failure	Consequence of failure	Recommended research
		Benefit	Penalty			
IHPTET Gen 5 Engine Technologies	<ul style="list-style-type: none"> <li>• Higher performance</li> <li>• Lower weight</li> <li>• Standard performance level for year 1997</li> </ul>	+30% T/W -20% TSFC	Higher cost	.40	.10	<ul style="list-style-type: none"> <li>• High strength, low weight materials</li> <li>• New aerodynamic design of compressors &amp; turbines</li> <li>• Efficient cooling techniques</li> </ul>
IHPTET Gen 6 Engine Technologies	<ul style="list-style-type: none"> <li>• Improved LO signature</li> <li>• Higher performance</li> <li>• Lower weight</li> <li>• Standard performance level for year 2008</li> </ul>	+60% T/W -30% TSFC	More complex system	.60	.50	<ul style="list-style-type: none"> <li>• Advanced cooling</li> <li>• Endothermic fuels</li> <li>• Engine controls</li> <li>• Materials</li> <li>• Ceramics</li> </ul>
FADEC/PSC Technologies	<ul style="list-style-type: none"> <li>• Controls with increased computing capability</li> <li>• Greater reliability</li> <li>• Reduced weight &amp; volume</li> </ul>	Optimized engine operation		.50	.20	Variable/engine control integration
Variable Cycle Engine Technologies	<ul style="list-style-type: none"> <li>• One solution to high thrust yet long endurance missions</li> <li>• Reduced fuel load</li> </ul>	Smaller vehicle due to reduced fuel load	<ul style="list-style-type: none"> <li>• Valving h/w is heavy</li> <li>• Reliability</li> <li>• Number of moving parts</li> </ul>	.20	.30	<ul style="list-style-type: none"> <li>• Bypass vs. core performance</li> <li>• Matching mission parameters</li> </ul>
F100/F110 Derivative Engine Technology	<ul style="list-style-type: none"> <li>• Lower cost</li> <li>• Available now</li> </ul>	Reliability base exists <ul style="list-style-type: none"> <li>• +20% FN</li> <li>• +25% T/W</li> <li>• -3% SFC</li> </ul>	Lower thrust/weight ratio	.20	.30	<ul style="list-style-type: none"> <li>• Mission tailored engine cycle</li> <li>• Derivative feasibility study</li> <li>• Cost vs. schedule vs. performance</li> </ul>
F119/F120 Derivative Engine Technology	<ul style="list-style-type: none"> <li>• Lower cost</li> <li>• Available near term</li> </ul>	<ul style="list-style-type: none"> <li>• +20% FN</li> <li>• 2 x turbine life</li> <li>• -5% SFC</li> </ul>	Lower thrust/weight ratio	.30	.30	<ul style="list-style-type: none"> <li>• Mission tailored engine cycle</li> <li>• Derivative feasibility study</li> <li>• Cost vs. schedule vs. performance</li> </ul>

Figure 3.1-7.

## Structures & Materials

Technology description	Selection rationale	← Configuration Impact →		Probability of failure	Consequence of failure	Recommended research
		Benefit	Penalty			
Advanced Aluminum-Lithium Alloys	Reduce weight of aluminum parts	10% weight reduction to 30% of structure	20% cost penalty	.50	.50	Caution: this has been tried before and FAILS due to poor ductility
Advanced Titanium Alloys	Reduce weight of titanium parts	10% weight reduction to 30% of structure	20% cost penalty	.50	.50	Caution: previous failures due to lack of weldability & crack growth
Powder Metallurgy (2 types) • Current Materials  • Metal Matrix Composites	Confusing! –  Only cost savings	\$ only	Needs development	.50	.50	Probably not worth effort
	Weight benefit: silicon titanium, etc.	30% weight savings on 50% of struct.	\$ cost increase	.50	.50	Putting fibers in metals (metal matrix composites) is potentially major benefit
Intermetal Ceramic		Weight savings in HOT areas. 20% of 1%.		.70	.50	Not used much in airframes – more application to engines
Rare Earth Alloys – Sapphire				0.7	0.6	Not used in airframe
Graphite Based Composites	• Save weight • Very smooth complex surfaces	10% weight savings to 40% of struct.	\$	.50	.10	Improved materials are nice, but breakthrough will be new joining and manufacturing methods
Boron Based Composites	• Save weight • Very stiff	10% weight savings to 40% of struct.	• Very expensive • Hard to work	0.3	0.7	Competes with graphite composites but more expensive

Figure 3.1-8.

### Structures & Materials (continued)

Technology description	Selection rationale	← Configuration Impact →		Probability of failure	Consequence of failure	Recommended research
		Benefit	Penalty			
Kevlar Based Composites	Kevlar is very tough & impact resistant	May save 20% weight on 10% of structure	\$, plus only helps impact sensitive parts	.50	.50	Past Kevlar use on 767 withdrawn due to service problems – water contamination
Fiberglass Based Composites	Graphite stiffer?	May save \$	May cost weight	.30	.30	Fiberglass widely used for lightly loaded parts, not new technology
Advanced Resins	Could save weight via improved toughness	10% weight savings on 40% of structure	May increase cost	.30	.30	Manufacturing, etc. is critical to success
Thermoplastic Materials (Arimid K. series developed by DuPont with High Glass Transition Polyamide Systems)	<ul style="list-style-type: none"> <li>• Very tough resin</li> <li>• Saves weight</li> <li>• Potential for manufacturing breakthroughs</li> </ul>	20% savings on 40% of structure	\$ for develop. but can save \$ in production	.30	.10	Again, real breakthrough will be innovative manufacturing, etc. (welding, co-curing)
Thermoset Materials	Could save weight via improved toughness	10% weight savings on 40% of structure	May increase cost	.30	.30	Manufacturing, etc. is critical to success
Advanced Manufacturing	<ul style="list-style-type: none"> <li>• Superplastic Forming</li> </ul>	10% weight savings on 30% of structure	\$ for develop. but can save \$ in production	.30	.30	Past efforts at SPF could not achieve minimum thicknesses required
<ul style="list-style-type: none"> <li>• T. Welding</li> <li>• Composite Welding</li> <li>• Z Pinning</li> </ul>	Could save cost and weight	20% weight savings on 70% of structure	\$ for develop. but can save \$ in production	.30	.10	All have major potential for future fighters

Figure 3.1-9.

23

### Structures & Materials (concluded)

Technology description	Selection rationale	Configuration Impact		Probability of failure	Consequence of failure	Recommended research
		Benefit	Penalty			
<b>Advanced Structural Techniques</b> • Welded Joints • Issogrid • Column Core • Z Pinning	Potential major weight & cost savings	Save weight & cost in production, 20% of structure	Development takes time & \$	.50	.30	More work is needed
<b>Active Flutter Suppression</b>	Potential major weight and drag savings	Save 10% of structure	High risk	.70	.90	Needs development on unmanned drone
<b>Aeroelastic Tailoring</b>	Saves weight	10% wt reduction on aircraft structure	Requires \$ & schedule time	.30	.30	
<b>Smart Structures</b>	• Saves weight • Improves sensor vs. tiny radome, etc.	10% of structure weight if cleverly done	Could add weight if poorly done	.70	.70	
<b>NEW – Control Surface Advanced Aero (Blown Surface, etc.)</b>	Improves maneuverability		<b>CAUTION –</b> Adding weight to surface has large "hidden" penalty in flutter required hydraulic system changes			

Figure 3.1-10.

## Avionics

Technology description	Selection rationale	Configuration Impact		Probability of failure	Consequence of failure	Recommended research
		Benefit	Penalty			
JIAWG/Pave Pillar Class Integrated Avionics	Off the shelf advanced system avionics	Reduced development \$	Increased weight relative to Pave Pace integrated avionics	.20	.10	Define growth path of RF & digital processing upgrades
Advanced Targeting FLIR, Integrated Nav FLIR/IRST/MLD	Multi-mission support	<ul style="list-style-type: none"> <li>• PGM support</li> <li>• Night low level flight</li> <li>• Situation awareness</li> </ul>	Development cost	0.5	.30	<ul style="list-style-type: none"> <li>• Combined multispectral apertures</li> <li>• Staring focal plane array</li> </ul>
Tiled Array Radar	Reduced weight	Potential for 50% weight reduction in radar	Development cost	0.5	.30	<ul style="list-style-type: none"> <li>• Advanced multilayer wafer IC on ceramic substrate</li> <li>• Planar slotted radiators</li> <li>• MMIC</li> <li>• Packaging (component &amp; substrate integration)</li> </ul>
Off Board Data Management	Reduced weight	Potential for 50% weight reduction in avionics	Development cost	0.4	.30	<ul style="list-style-type: none"> <li>• Reduced RCS comm. apertures &amp; receiver sensitivity</li> <li>• Data fusion</li> </ul>
Common RF Modules	Reduced weight	<ul style="list-style-type: none"> <li>• Reduced weight</li> <li>• Lower LCC</li> </ul>	Development cost	0.8	.40	Integrated Sensor Systems (ISS)

Figure 3.1-11.

## VMS Technologies

Technology description	Selection rationale	← Configuration Impact →		Probability of failure	Consequence of failure	Recommended research
		Benefit	Penalty			
Photonics • Cables & Connectors	Reduced system weight	50% weight reduction	Increased interface wt.	.20	.60	• Low loss connectors • Life testing • Field repair
• I/O Interfaces	Reduced system weight	Increased BW	Increased complexity	.50	.60	• High temperature • High power sources • High sensitivity receivers
• Sensors	Reduced system weight	10% weight reduction	Increased complexity	.50	.60	• Low loss sensors • Life testing
High Speed Photonic Databuses	• Reduced weight • Increased BW	50% weight reduction	Increased complexity	.30	.60	• Flight critical applications • Redundant bus synchronization
High Temperature Electronics	Reduced system weight	50% weight reduction		.20	.40	• High density/temperature electronics packaging • Life testing
Smart Sensors/ Smart Actuators	Reduced system weight	25% weight reduction	Increased cooling sys.weight	.10	.40	• Advanced actuator packaging • Redundancy analysis
Improved Processing • Fault Tolerant Processors • 32 Bit Processors	• Increased system performance & reliability • Reduced maintenance	Reduced LCC (20%)	Increased complexity	.10	.30	Redundancy considerations
Modular Rack Mounted Electronics	Reduced maintenance (LCC)	Reduced LCC (15%)	Increased complexity	.10	.20	Advanced packaging
Rapid Prototyping Hardware & Software	Reduced development cycle time	Reduced development cost (35%)		.20	.30	Development tools

Figure 3.1-12.



### VMS Technologies (concluded)

Technology description	Selection rationale	← Configuration Impact →		Probability of failure	Consequence of failure	Recommended research
		Benefit	Penalty			
Reusable Software	Reduced development cost	Reduced development cost (25%)		.30	.30	Modular software development tools
Integrated Tool Environment • Reliability & Performance • Requirements & Specs	Reduced development cycle time & cost	Reduced development cost (25%)		.50	.30	Abstract representation of system functionality and requirements
Subsystem Utilities Integration Technology (SUIT) • Integrated Closed ECS • Integrated Power Unit • Thermal & Energy Management Module	• Reduced weight • Increased energy utilization • Reduced maintenance cost	50% weight reduction		.30	.50	• Physical & functional integration • Suitability of different fluids • Energy utilization • Advanced packaging
Improved Hydraulic System Concepts • Variable Pressure Hydraulic Systems • Variable Area Actuators • Power/Control by Light	Increased vehicle performance	5% increased performance	Increased complexity	.60	.60	• Energy optimization • High powered, high reliability optical sources
More Electric Airplane Concepts • Electromechanical Actuators • Electrohydrostatic Actuators • Integrated Actuator Packages	Reduced maintenance cost	10% reduced maintenance cost	Increased complexity	.50	.50	Reliability & lift testing
Integrated Flight & Propulsion Control • Surface Reconfiguration • Thrust Vectoring • STOVL • Optical Air Data • Flush Port Air Data	Improved performance	10% increased performance	Increased complexity	.02	.40	• Flight control surface redundancy • Vehicle performance • Advanced control laws

Figure 3.1-13.

## Crew Systems

Technology description	Selection rationale	Configuration Impact		Probability of failure	Consequence of failure	Recommended research
		Benefit	Penalty			
Helmet-Mounted Display – Monochrome	<ul style="list-style-type: none"> <li>• Reduce control/display suite wt. (replaces HUD)</li> <li>• Increase situation awareness</li> <li>• Reduce workload</li> </ul>	<ul style="list-style-type: none"> <li>• 10-15% reduction in C&amp;D suite weight</li> <li>• Reduced restriction on fore canopy shape</li> </ul>	Canopy may need to be slightly wider or higher (~10% Δ)	.45	.30	<ul style="list-style-type: none"> <li>• Optical design/fov/weight reduction</li> <li>• Position tracking accuracy &amp; throughput</li> <li>• Symbology</li> <li>• Pilot performance Δ</li> </ul>
Helmet-Mounted Display – Color	<ul style="list-style-type: none"> <li>• Reduce control/display suite wt. (replaces HUD)</li> <li>• Increase situation awareness</li> <li>• Reduce workload</li> </ul>	<ul style="list-style-type: none"> <li>• 10-15% reduction in C&amp;D suite weight</li> <li>• Reduced restriction on fore canopy shape</li> </ul>	Canopy may need to be slightly wider or higher (~10% Δ)	.75	.70	<ul style="list-style-type: none"> <li>• Color mini-CRT</li> <li>• Above topics</li> <li>• Color-coding</li> </ul>
Laser-Hardening Technologies	<ul style="list-style-type: none"> <li>• Increased pilot survivability</li> <li>• Mission effectiveness</li> </ul>	<ul style="list-style-type: none"> <li>• Increased pilot survivability</li> <li>• Mission effectiveness</li> </ul>	~10% increase in canopy weight or cockpit systems weight	.70	.60	<ul style="list-style-type: none"> <li>• Multiple wavelength sensitivity</li> <li>• Response time to first pulse</li> <li>• Aircraft vs. pilot-mounted</li> </ul>
Night Vision Systems	<ul style="list-style-type: none"> <li>• Improve low light operations perf.</li> <li>• Mission effectiveness</li> </ul>	<ul style="list-style-type: none"> <li>• Improve low light operations perf.</li> <li>• Mission effectiveness</li> </ul>	<5% weight increase	.30	.30	<ul style="list-style-type: none"> <li>• Compatible cockpit lighting</li> <li>• Sys. size &amp; wt. reduction</li> </ul>
Panoramic Display	<ul style="list-style-type: none"> <li>• Reduced C&amp;D suite weight</li> <li>• Reduced no. of units</li> </ul>	>25% reduction in display weight	Front panel shape will be more rectangular	.90	.50	<ul style="list-style-type: none"> <li>• Large color flat panel development</li> <li>• Symbology design</li> </ul>
3-D Audio	Increased situation/spatial awareness	Increased situation/spatial awareness	Minor weight increase	.50	.75	<ul style="list-style-type: none"> <li>• Determine task perf. improvement</li> <li>• Position tracking system improvement</li> <li>• PCB enhancement</li> </ul>
Flat Panel Display Technology	<ul style="list-style-type: none"> <li>• Reduced display weight</li> <li>• Power &amp; cooling needs</li> </ul>	<ul style="list-style-type: none"> <li>• &gt;25% reduction in display weight</li> <li>• Power, cooling needs</li> <li>• Less behind-panel depth required</li> </ul>		.30	.25	<ul style="list-style-type: none"> <li>• Increase display perf. (brightness, resolution, color)</li> <li>• Manufacturing methods</li> </ul>

28

## Weapons

Technology description	Selection rationale	Configuration Impact		Probability of failure	Consequence of failure	Recommended research
		Benefit	Penalty			
Internal Weapons Carriage	Reduce signature and drag	<ul style="list-style-type: none"> <li>Signature reduction of 30-40%</li> <li>Drag reduction of 10-20%</li> </ul>	Weight increase of 5-15%	.30	.30	<ul style="list-style-type: none"> <li>Weapons separation</li> <li>Aeroacoustics</li> <li>Suspension &amp; release equipment</li> </ul>
External/Pylon Mounted Carriage	<ul style="list-style-type: none"> <li>Reduce aircraft weight</li> <li>Simpler loading</li> </ul>	<ul style="list-style-type: none"> <li>Smaller aircraft</li> <li>Lighter weight</li> </ul>	<ul style="list-style-type: none"> <li>Drag increase of 10-30%</li> <li>Not LO high signature</li> </ul>	.20	.10	<ul style="list-style-type: none"> <li>Weapons separation</li> <li>Suspension &amp; release equipment</li> </ul>
Conformal Carriage	Reduce aircraft weight and size	<ul style="list-style-type: none"> <li>Smaller aircraft</li> <li>Lighter weight</li> <li>Reduced signature from external carriage</li> </ul>	<ul style="list-style-type: none"> <li>Higher drag than internal carriage</li> <li>Lower signature than external carriage</li> </ul>	.50	.30	<ul style="list-style-type: none"> <li>Conformal weapons</li> <li>Conformal suspension &amp; release</li> <li>Aircraft design</li> </ul>
Gravity Weapons	Cheap & available in large quantity	Asset or liability depending on carriage mode selected	Asset or liability	.10	.10	<ul style="list-style-type: none"> <li>Weapons separation</li> <li>Suspension &amp; release equipment</li> </ul>
Laser Guided Weapons	Requirement for precision delivery	Asset or liability depending on carriage mode selected	Asset or liability	.10	.10	<ul style="list-style-type: none"> <li>Avonics integration</li> <li>Suspension &amp; release equipment</li> </ul>
Autonomous Guidance Weapons	<ul style="list-style-type: none"> <li>Standoff requirement</li> <li>Eliminate man-in-the-loop</li> </ul>	Improved survivability	More complex weapons & avionics integration	.30	.30	<ul style="list-style-type: none"> <li>Fiber optics</li> <li>Operations</li> <li>Sensor fusion</li> <li>Stores management system</li> <li>Pave Pillar architecture</li> </ul>

Figure 3.1-15.

### Weapons (concluded)

Technology description	Selection rationale	Configuration Impact		Probability of failure	Consequence of failure	Recommended research
		Benefit	Penalty			
"All Envelope" Air-to-Air Weapons	Air-to-air and self-defense requirement	<ul style="list-style-type: none"> <li>• Survivability</li> <li>• Offensive capability</li> <li>• Doors, launchers, pylons, etc.</li> </ul>	<ul style="list-style-type: none"> <li>• Weight</li> <li>• Avionics integration</li> </ul>	.50	.40	<ul style="list-style-type: none"> <li>• Sensor fusion</li> <li>• Helmet mounted sight</li> <li>• Weapons separation</li> <li>• Advanced suspension &amp; release equipment</li> </ul>
Ballistic Weapons "Guns"	<ul style="list-style-type: none"> <li>• Close-in mill requirement</li> <li>• Simplicity</li> </ul>	None	<ul style="list-style-type: none"> <li>• Weight</li> <li>• LO integration</li> <li>• Space for effective guns</li> </ul>	.20	.10	<ul style="list-style-type: none"> <li>• Improved guns</li> <li>• Body/wing integration</li> </ul>
Hypervelocity Weapons	Hardened target mill standoff requirement	Can be substantial depending on carriage mode	<ul style="list-style-type: none"> <li>• Weight</li> <li>• Rocket motor blast</li> </ul>	.20	.20	<ul style="list-style-type: none"> <li>• Weapons geometry</li> <li>• Weapons separation</li> <li>• Suspension &amp; release equipment</li> </ul>
HARM or Other SEAD Weapons	Self-defense capability	None	Substantial impact to config. is carried in internal bays or conformally	.30	.30	<ul style="list-style-type: none"> <li>• Compact/conformal weapons</li> <li>• Suspension &amp; release equipment</li> </ul>
Cruise Missile or UAV Carriage	Standoff or RECCE requirements	None	<ul style="list-style-type: none"> <li>• Substantial if carried internally both in weight, bay volume, and aircraft size</li> <li>• Conformal carriage may not be possible for UAV due to size</li> </ul>	.30	.30	<ul style="list-style-type: none"> <li>• Suspension &amp; release equipment</li> <li>• Wing design</li> <li>• Fuselage design &amp; weapons integration</li> </ul>

Figure 3.1-16.

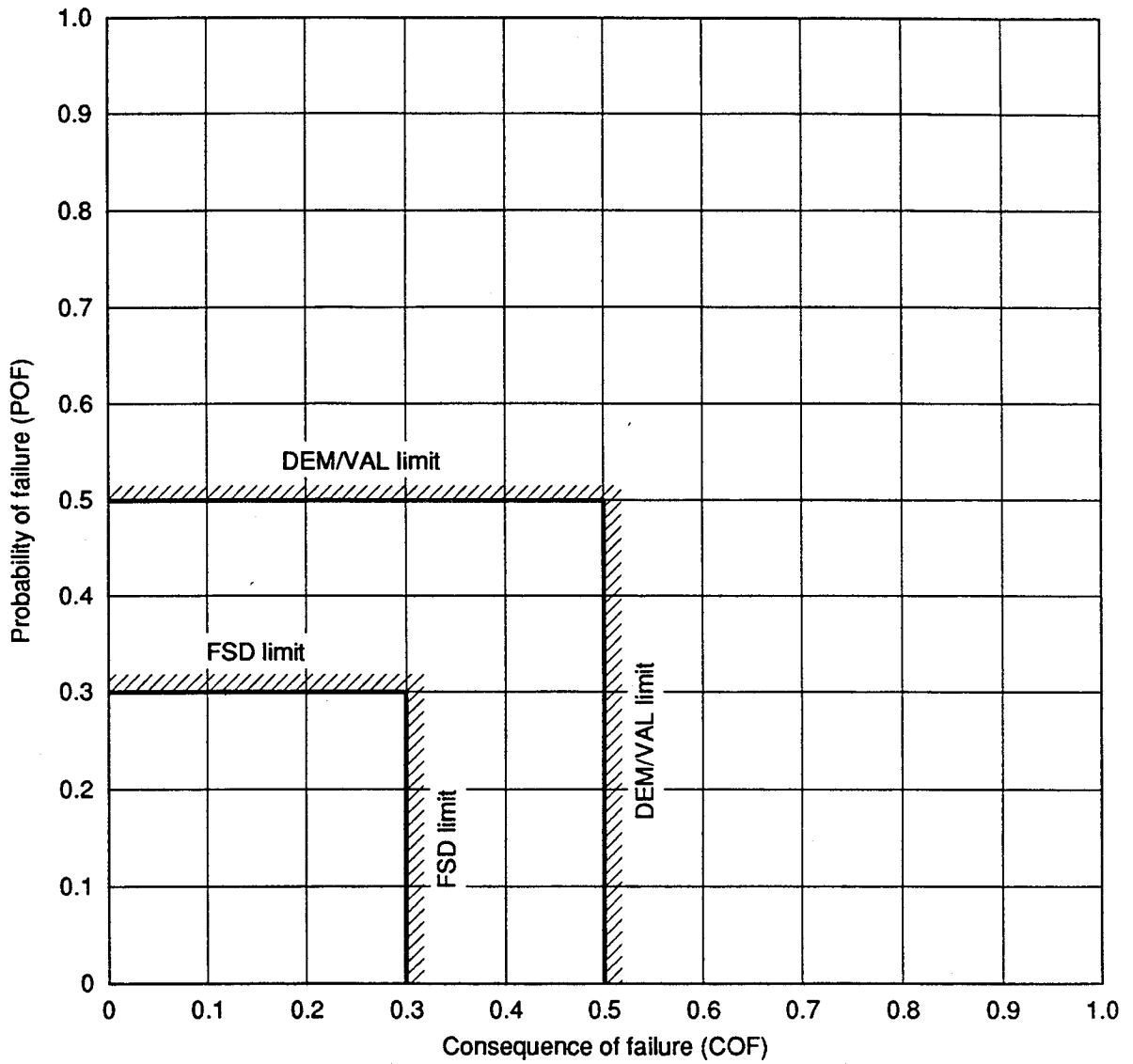

Figure 3.1-17. Sample Technology Risk Assessment Criteria

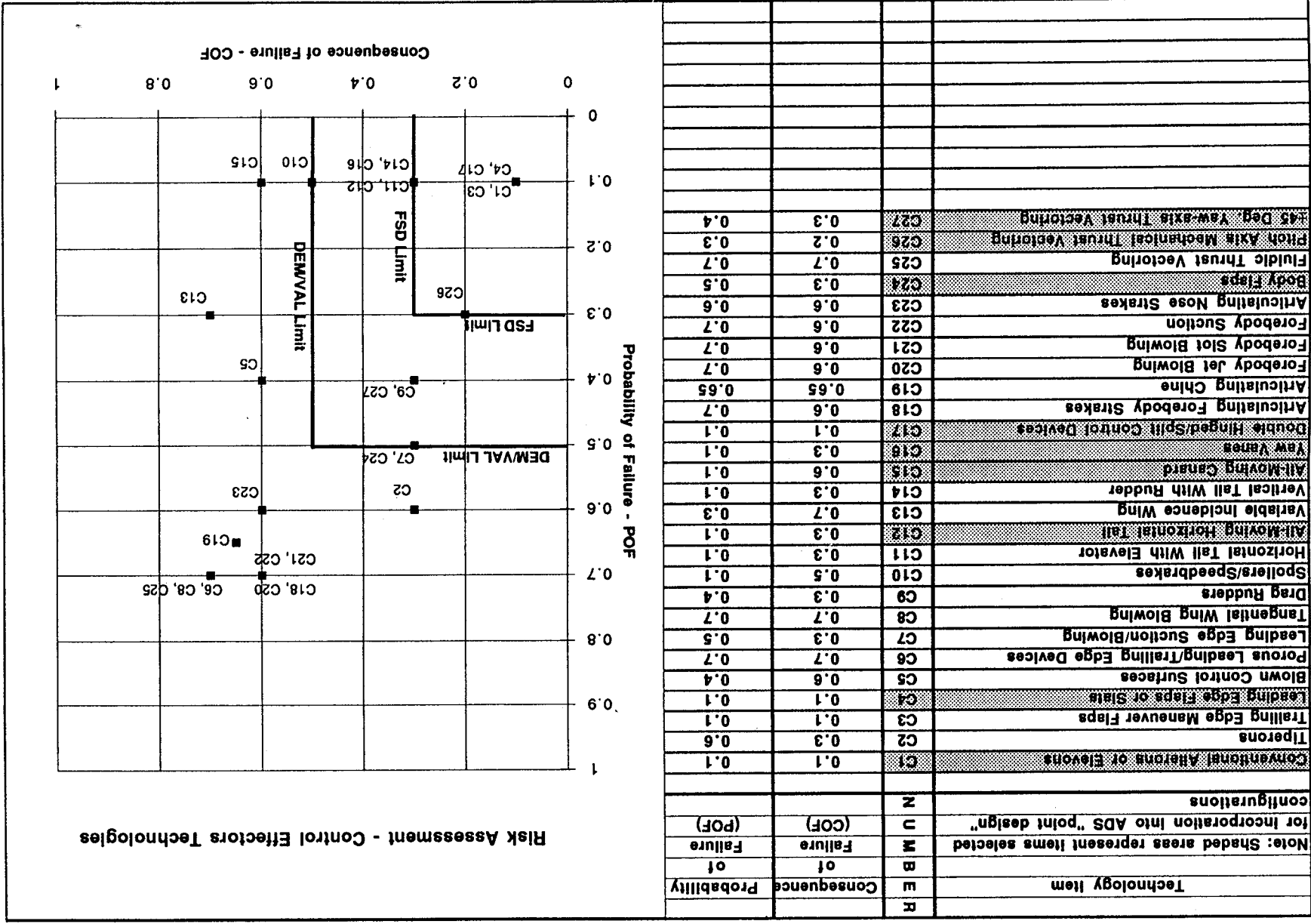

Figure 3.1-18



Technology Item	R E B M C Z	Consequence of Failure (COF)	Probability of Failure (POF)
Advanced Aluminum-Lithium Alloys	S1	0.5	0.5
Advanced Titanium Alloys	S2	0.5	0.5
Powder Metallurgy - Current Materials	S3	0.5	0.5
Powder Metallurgy - Metal Matrix Comp.	S4	0.5	0.5
Intermetal Ceramic	S5	0.5	0.7
Rare Earth Alloys - Sapphire	S6	0.7	0.6
Graphite Based Composites	S7	0.1	0.5
Boron Based Composite	S8	0.7	0.3
Kevlar Based Composites	S9	0.5	0.5
Fiberglass Based Composites	S10	0.3	0.3
Advanced Resins	S11	0.3	0.3
Thermoplastic Materials	S12	0.1	0.3
Thermoset Materials	S13	0.3	0.3
Advanced Manuf'g - Superplastic Forming	S14	0.3	0.3
Advanced Manuf'g - Titanium Welding	S15	0.1	0.3
Advanced Manuf'g - Composite Welding	S16	0.1	0.3
Advanced Manuf'g - Z Pinning	S17	0.1	0.3
Advanced Techniques - Welded Joints	S18	0.3	0.5
Advanced Techniques - Isogrid	S19	0.3	0.5
Advanced Techniques - Column Core	S20	0.3	0.5
Advanced Techniques - Z Pinning	S21	0.3	0.5
Active Flutter Suppression	S22	0.9	0.7
Aeroelastic Tailoring	S23	0.3	0.3
Titanium Matrix Composite	S24	0.5	0.5
Advanced Carbon-Carbon Composite	S25	0.5	0.5
Smart Structures	S26	0.7	0.7

Risk Assessment - Structures & Mat'ls Technologies

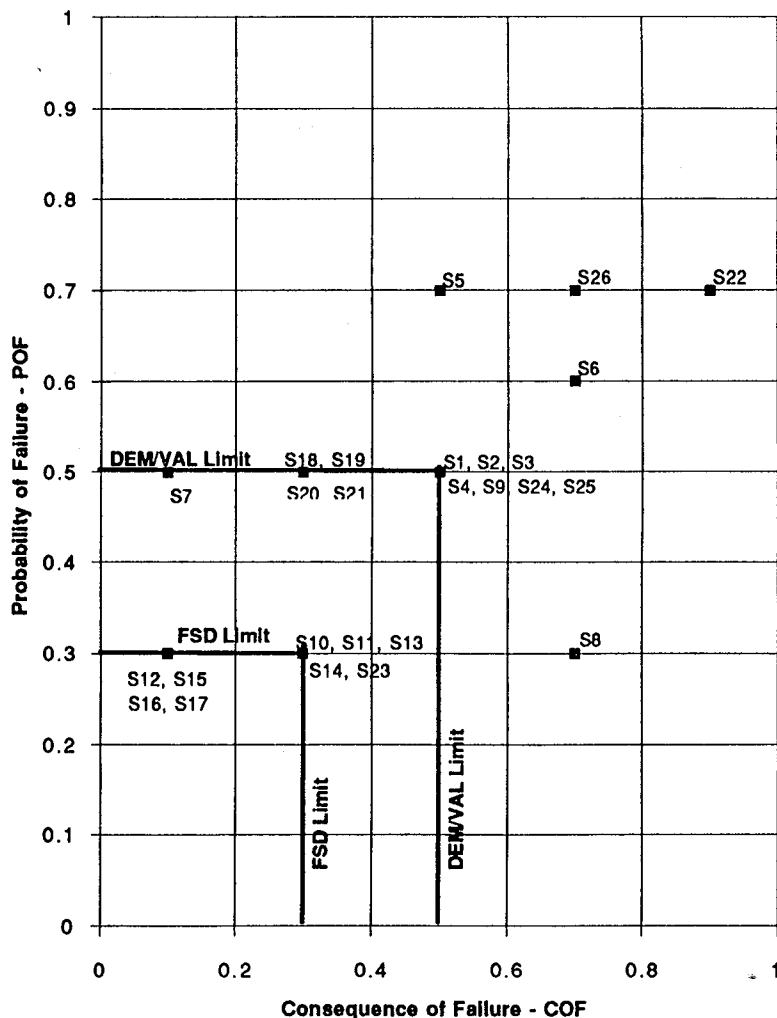

Figure 3.1-20

34

ORIGINAL PAGE IS  
OF POOR QUALITY



CS

Technology Item	R	Consequence	Probability
	E	of	of
Note: Shaded areas represent Items selected for incorporation into ADS "point design" configurations	M	Failure	Failure
	J	(COF)	(POF)
	Z		
JIAWG/Pave Pillar Class Integrated Avionics	E1	0.1	0.2
Advanced Targeting FLIR	E2	0.3	0.5
Integrated Nav FLIR/IRST/MLD	E3	0.3	0.5
Tiled Array Radar	E4	0.3	0.5
Off Board Data Management	E5	0.3	0.4
Common RF Modules	E6	0.4	0.8
Reusable Software	V1	0.3	0.3
Subsystem Utilities Integration Tech. (SUIT)	V2	0.5	0.3
Integrated Closed ECS	V3	0.5	0.3
Integrated Power Unit	V4	0.5	0.3
Thermal & Energy Management Module	V5	0.5	0.3
Variable Pressure Hydraulic Systems	V6	0.6	0.6
Variable Area Actuators	V7	0.6	0.6
Power/Control by Light	V8	0.6	0.6
Electromechanical Actuators	V9	0.5	0.5
Electrohydrostatic Actuators	V10	0.5	0.5
Integrated Actuator Packages	V11	0.5	0.5
Surface Reconfiguration	V12	0.4	0.2
Optical Air Data	V13	0.4	0.2
Flush Port Air Data	V14	0.4	0.2
Photonics - Cables & Connectors	V15	0.6	0.2
Photonics - I/O Interfaces	V16	0.6	0.5
Photonics - Sensors	V17	0.6	0.5
High Speed Photonic Databuses	V18	0.6	0.3
High Temperature Electronics	V19	0.4	0.2
Smart Sensors/Smart Actuators	V20	0.4	0.1
Fault Tolerant Processors	V21	0.3	0.1
32 Bit Processors	V22	0.3	0.1
Modular Rack Mounted Electronics	V23	0.2	0.1
Rapid Prototyping Hardware and Software	V24	0.3	0.2
High Pressure Hydraulics	V25	0.4	0.4
Integrated Tool Environment	V26	0.3	0.5

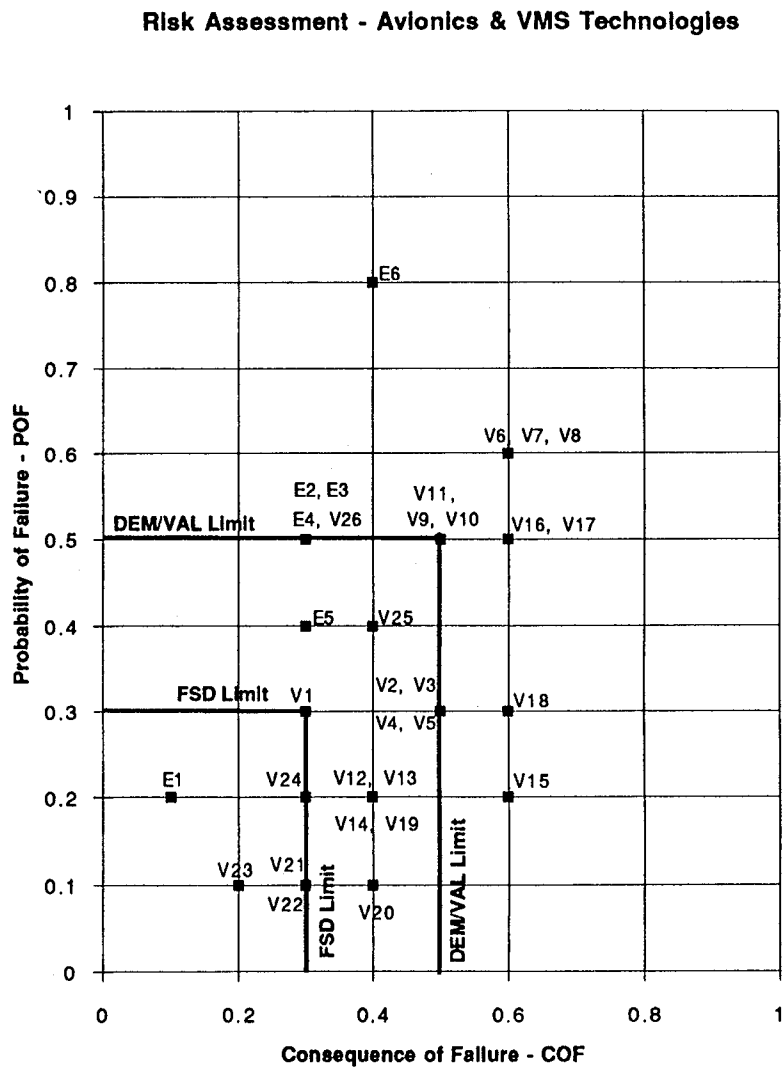

Figure 3.1-21



### 3.2 Technologies used in Agility Study Configurations

The technology elements selected to be used for each point design configuration are shown on Tables 3.2-1 and 3.2- 5. The majority of the chosen technologies are common to all configurations , with the only exceptions being in the "Control Effectors" selections. Also, most of the applied technologies risk levels are within the pre-established DEM/VAL limits. The exceptions being the all-moving canard, power/control-by-light and IHPTET Gen 6 engine technology.

Principal impact on configuration development resulted from incorporation of projected technology benefits in five major functional areas.

- **Main Engines**            Use of IHPTET "Gen 6" engines resulted in significant weight and size reductions in the overall propulsion system (inlet, diffuser, engine bay and exhaust duct). Engine mass location within the airplane was less of a driving issue to achieve air vehicle balance.
  
- **Avionics**                Principal benefits to airplane configuration resulted from reductions in weight and volume for both the modules or units and the interconnection system. Cascading benefit to the environmental control system for reduced cooling loads results in further volume reduction.
  
- **Subsystems**            Expanded technology development in flight controls actuation, secondary power generation and control, ECS, and management/integration of functional components are considered as contributions to obtaining sufficient or expanded capability within available or reduced airframe envelopes. The resultant anticipated is improved installation density or volume utilization.
  
- **Structural Materials**    Application of next generation composites, such as Titanium Matrix Composites (TMC), permits the implementation of unique design features not feasible with conventional materials because of fabrication complexity, environment limits, or weight impact on vehicle performance.

### 3.3 Weight and Cost Impact of Advanced Technologies

The Boeing developed parametric/statical Level 1 weight prediction methods used to estimate the group weights of the ADS "point design" configurations contain weight considerations for some of the technology items selected for incorporation into the designs. These items are not considered "advanced technology" and include items such as conventional ailerons, leading edge flaps or slats, all-moving horizontal tail, supercritical wing, electromechanical actuators, etc. Weight increments for incorporation of these devices are not specifically called out as special features. Tables 3.3-1 and 3.3-2 show the advanced technology application weight effects. These features required special consideration, outside the standard method, when estimating their weights.

Projected weights for IOC 2005 avionics suites for the air-to-air and multi-role missions are shown on figures 3.3-3 and 3.3-4. The air-to-ground avionics suite was considered to be identical to the multi-role. Advanced technology assumptions used to generate these weights are presented on the tables. F-22 avionics weights were used as the base points and the advanced technology weight effects were applied on a system-by-system basis.





### Structures and Materials

Technology Item	R E B M J Z	Air Force						Joint Services					
		A / A		M / R		A / G		A / A		M / R		A / G	
		988 -114	988 -115	988 -118	988 -119	988 -122	988 -123	988 -116	988 -117	988 -120	988 -121	988 -124	988 -125
Advanced Aluminum-Lithium Alloys	S1												
Advanced Titanium Alloys	S2												
Powder Metallurgy - Current Materials	S3												
Powder Metallurgy - Metal Matrix Composites	S4												
Intermetal Ceramic	S5												
Rare Earth Alloys - Sapphire	S6												
Graphite Based Composites	S7												
Boron Based Composite	S8												
Kevlar Based Composites	S9												
Fiberglass Based Composites	S10												
Advanced Resins	S11												
Thermoplastic Materials	S12												
Thermoset Materials	S13												
Advanced Manufacturing - Superplastic Forming	S14												
Advanced Manufacturing - Titanium Welding	S15												
Advanced Manufacturing - Composite Welding	S16												
Advanced Manufacturing - Z Pinning	S17												
Advanced Techniques - Welded Joints	S18												
Advanced Techniques - Issogrid	S19												
Advanced Techniques - Column Core	S20												
Advanced Techniques - Z Pinning	S21												
Active Flutter Suppression	S22												
Aeroelastic Tailoring	S23												
Smart Structures	S24												
Titanium Matrix Composite	S25												
Advanced Carbon-Carbon Composite	S26												

40

Figure 3.2-3

## Avionics and Vehicle Management Systems

Technology Item	R E B M J Z	Air Force						Joint Services					
		A / A		M / R		A / G		A / A		M / R		A / G	
		988 -114	988 -115	988 -118	988 -119	988 -122	988 -123	988 -116	988 -117	988 -120	988 -121	988 -124	988 -125
JIAWG/Pave Pillar Class Integrated Avionics	E1												
Advanced Targeting FLIR	E2												
Integrated Nav FLIR/IRST/MLD	E3												
Tiled Array Radar	E4												
Off Board Data Management	E5												
Common RF Modules	E6												
Reusable Software	V1												
Subsystem Utilities Integration Tech. (SUIT)	V2												
Integrated Closed ECS	V3												
Integrated Power Unit	V4												
Thermal & Energy Management Module	V5												
Variable Pressure Hydraulic Systems	V6												
Variable Area Actuators	V7												
Power/Control by Light	V8												
Electromechanical Actuators	V9												
Electrohydrostatic Actuators	V10												
Integrated Actuator Packages	V11												
Surface Reconfiguration	V12												
Optical Air Data	V13												
Flush Port Air Data	V14												
Photonics - Cables & Connectors	V15												
Photonics - I/O Interfaces	V16												
Photonics - Sensors	V17												
High Speed Photonic Databases	V18												
High Temperature Electronics	V19												
Smart Sensors/Smart Actuators	V20												
Fault Tolerant Processors	V21												
32 Bit Processors	V22												
Modular Rack Mounted Electronics	V23												
Rapid Prototyping Hardware and Software	V24												
Integrated Tool Environment	V25												
High Pressure Hydraulics	V26												

41

Figure 3.2-4





Technology Description	Selection Rationale	Group Application	← Weight Impact →		← Cost Impact →	
			Weight Effects	EMD	Average Unit Production	250 A/G Buy Production
Yaw Vanes – Advanced Composite	Extendable low risk yaw control surfaces	Yaw vanes	6.32 lbs/sq ft of surface area (including controls)	\$12,700/ft <sup>2</sup>	\$218/ft <sup>2</sup>	
Split Control Surfaces	Increased yaw control	Control surface	31% weight penalty	(+) \$10.5M	(+) \$0.18M	(+) \$45M
Pitch Axis Thrust Vectoring – Aft Body Flaps in Exhaust	<ul style="list-style-type: none"> <li>• High AOA pitch control</li> <li>• Increased maneuverability</li> </ul>	Body	10 lbs/sq ft of flap area (including controls)	\$8,045/ft <sup>2</sup>	\$138/ft <sup>2</sup>	
Internal Weapons Carriage	Signature and drag reduction	Body	18 to 23% body weight penalty depending on cutout size	(+) \$80-\$104M	(+) \$1.0-1.4M	(+) \$250-350M
2005 IOC Integrated Avionics <ul style="list-style-type: none"> <li>• JIAWG Integrated Avionics</li> <li>• Advanced Targeting FLIR</li> <li>• Integrated Navigation FLIR/IRST/MLD</li> <li>• Tiled Array Radar</li> <li>• Off-Board Data Management</li> <li>• Modular Rack Mounted</li> <li>• Flush Air Data Port</li> <li>• Reusable Software</li> <li>• Helmet-Mounted Display – Monochrome</li> <li>• Night Vision Systems</li> <li>• Flat Panel Displays</li> </ul>	Reduced weight	Avionics	1,000 to 1,200 lbs savings over present day integrated avionics installations  Note: see tables for Mission Avionics weights buildups	(-) \$65M	(-) \$1.7M	(-) \$425M
Integrated Actuator Packages	Reduced maintenance cost	Weapon multi-mode launchers	50 lb penalty to each launcher, reduced functions for the main aircraft hydraulic system saves weight depending on the number of weapons carried	(+) \$1.8M/launcher	(+) 0.05M/launcher	

Figure 3.3-1. Advanced Technology Applications – Weight and Cost Effects

Technology Description	Selection Rationale	Group Application	Weight Impact		Cost Impact	
			Weight Effects	EMD	Average Unit Production	250 A/G Buy Production
Combined effects of: <ul style="list-style-type: none"> <li>• Thermoplastic Materials</li> <li>• Thermoset Materials</li> <li>• Graphite Based Composites</li> <li>• Fiberglass Based Comp.</li> <li>• Advanced Manufacturing               <ul style="list-style-type: none"> <li>– Titanium Welding</li> <li>– Z Pinning</li> </ul> </li> <li>• Advanced Structural Techniques               <ul style="list-style-type: none"> <li>– Welded Joints</li> <li>– Z Pinning</li> </ul> </li> </ul>	<ul style="list-style-type: none"> <li>• Weight savings</li> <li>• Cost savings</li> <li>• Improved toughness</li> <li>• Potential for manufacturing breakthroughs</li> </ul>	<ul style="list-style-type: none"> <li>• Wing structural box</li> <li>• Wing control surfaces</li> <li>• Wing secondary structure</li> <li>• Horizontal and vertical tails</li> <li>• Body structure</li> <li>• Air inlet</li> </ul>	-17% -20% -22% -25% -12% -15%	(-) \$92.3M	(-) \$1.31M	(-) \$327M
Combined effects of: <ul style="list-style-type: none"> <li>• Titanium Matrix Composite</li> <li>• Powder Metallurgy</li> <li>• Superplastic Forming</li> <li>• Advanced Carbon-Carbon Composites</li> </ul>	<ul style="list-style-type: none"> <li>• Weight savings</li> <li>• Use at exhaust temperatures</li> <li>• High strength</li> </ul>	Exhaust nozzles	35%	(-) \$27.8M	(-) \$0.9M	(-) \$225M
IHPTET Gen 6 Advanced Engines Technologies (including FADEC/PSC)	<ul style="list-style-type: none"> <li>• Higher performance</li> <li>• Lighter weight</li> <li>• Reduced SFC</li> </ul>	Engine	50 to 60% T/W increase over existing dry gas turbines	(+) \$1.2B	Use CER * 1.0816	
High Pressure Hydraulics	Lighter weight	Hydraulic system	-12%	(-) \$3.7M	(-) \$0.05M	(-) \$12.5M
Power and Control-by-Light Flight Controls	Cable/wire weight savings	Surface controls	-22%	(-) \$17.4M	(-) \$0.3M	(-) \$75M
Yaw Axis Vectored Thrust ± 45 Degrees	Low risk approach to yaw control power	Exhaust system	42 to 52% increase over a nonvectoring dry or A/B nozzle	(+) \$33.3-41.3M	(+) \$1.1-1.4M	(+) \$275-350M

Figure 3.3-2. Advanced Technology Applications – Weight and Cost Effects

# Austere Avionics Suite for an Air-to-Air Agile Fighter

45

Subsystem	Weight (lbs)			Power (KW)	Vol (ft3)	Capabilities	Comments
	Uninstld	Instln	Total				
Radar	214	17	231	18.4	1.6	• Air-to-Air (@ 100% range relative to F-22)	Tiled Array Radar
EO	74	8	82	0.25	0.7	• Integrated Nav-FLIR/MLD/LW/IRST (360 Deg Az, +/-45 El)	• Distributed IR System Technology
CNI	318	81	399	4.5	8.3	UHF (Have Quick), VHF, IFF Int/Trans., Band 2 DF, ESM, JTIDS, Landing Aids, GPS, IRS	• F-22 Technology • Additional functions to consider: SATCOM, IFDL, TACTS
EW	246	114	360	4	5.1	RWR (4 $\pi$ ), Forward PDF, ESM, Countermeasures	MLD/Laser Warn. Provided by EO
C's & D's	105	25	130	1.3	1.4	Primary MFD, 2 Secondary MFD's, UFCP's, AVTR, ICP, Backup C's&D's	Use HMD to Replace HUD
SMS	91	148	239	0.6	1.6	Monitoring/Control AA & AG Weapons, Gun, CM, Doors, Spoilers & Launchers	
Core Proc.	125	2	127	4	2.7	Data Transfer, Mass Memory, Mission Mngmt, Subsystem Mgr, CNI crypto, data, signal & display processing	• High Commonality with F-22 SW • Improved MCM Packaging • Processor, Memory Upgrades
Sub Total	1173	396	1569	33.1	21.4		
VMS	105	58	163	1.2	0.5	Utility Mngmt Comp., Flight Control Comp., Sensors, Air Data	
Misc.	54	15	69			Stick, Throttle, Pedals & Misc. Instruments	
<b>Total</b>	<b>1332</b>	<b>469</b>	<b>1801</b>	<b>34.3</b>	<b>21.9</b>		

 Advanced Technology

Figure 3.3-3.

# Austere Avionics Suite for a Multi-Role Agile Fighter

Subsystem	Weight (lbs)			Power (KW)	Vol (ft3)	Capabilities	Comments
	Uninstld	Instln	Total				
Radar	164	13	177	12.4	1.3	<ul style="list-style-type: none"> <li>Air-to-Air (@ 70% range relative to F-22)</li> <li>Air-to-Ground: RBGM, SAR, GMTI, TF/TA</li> </ul>	Tiled Array Radar
EO	229	27	256	2.8	3.7	<ul style="list-style-type: none"> <li>Targeting FLIR/Laser</li> <li>Integrated Nav-FLIR/MLD/LW/IRST (360 Deg Az, +/-45 El)</li> </ul>	<ul style="list-style-type: none"> <li>Multi-Spectral Aperture Technology</li> <li>Distributed IR System Technology</li> </ul>
CNI	327	84	411	4.5	8.4	UHF (Have Quick), VHF (SINCGARS, AHS), JTIDS, IFF Int/Trans., Band 2 DF, ESM, RALT., Landing Aids, GPS, IRS	<ul style="list-style-type: none"> <li>F-22 Technology</li> <li>Additional functions to consider: SATCOM, IFDL, TACTS</li> </ul>
EW	246	114	360	4	5.1	RWR (4 $\pi$ ), Forward PDF, ESM, Countermeasures	MLD/Laser Warn. Provided by EO
C's & D's	105	25	130	1.3	1.4	Primary MFD, 2 Secondary MFD's, UFCP's, AVTR, ICP, Backup C's&D's	Use HMD to Replace HUD
SMS	91	148	239	0.6	1.6	Monitoring/Control AA & AG Weapons, Gun, CM, Doors, Spoilers & Launchers	
Core Proc.	125	2	127	4	2.7	Data Transfer, Mass Memory, Mission Mngmt, Subsystem Mgr, CNI crypto, data, signal & display processing	<ul style="list-style-type: none"> <li>High Commonality with F-22 SW</li> <li>Improved MCM Packaging</li> <li>Processor, Memory Upgrades</li> </ul>
Sub Total	1287	413	1700	29.6	24.2		
VMS	105	58	163	1.2	0.5	Utility Mngmt Comp., Flight Control Comp., Sensors, Air Data	
Misc.	54	15	69			Stick, Throttle, Pedals & Misc. Instruments	
<b>Total</b>	<b>1446</b>	<b>486</b>	<b>1932</b>	<b>30.8</b>	<b>24.7</b>		

 Advanced Technology

Figure 3.3-4.

## **4.0 Configuration Development**

The process used to develop the concepts is presented in figure 4.1. The initial configuration matrix configurations and desirable features were developed in round table discussions by the Design Team. The selected assumptions, ground rules, number of engines, crew size and observables guidelines are all a product of team decision-making. In parallel to the Design Team, a technology risk assessment was undertaken by the Boeing Military Airplanes (BMA) Technology Staff. The results of this technology risk assessment guided the subsystems and technologies selected for incorporation into the design concepts.

### **4.1 Assumptions and Ground Rules**

#### **Single Crew**

A single crewman concept was selected as the basis of all the configurations in this study. Improvements in avionics and crew systems technologies will allow a single pilot to manage the workload now being accomplished by a pilot and a weapons officer. Reducing the number of personnel to enemy fire and reduced overall operating costs are added benefits of a single man crew over a two man crew concept.

A single pilot/crew station is incorporated in each air vehicle concept. Mission and flight subsystems postulated for usage in these vehicles will permit operation and control throughout all flight phases by one person.

Benefits accrue, from the single person crew, in reduced airframe and subsystems volume, weight and cost while satisfying mission performance requirements.

Survivability in threat environments or intense workload mission segments (terrain following, target area, and air combat), where extra eyes have proven valuable, will now require systems technology to provide situation awareness, threat position data, and target acquisition/tracking for single person operation at flight critical reliability levels.

#### **Twin Engine**

The use of twin engines for all the concepts was a ground rule established early as a result of a number of observations. The Navy has a strong bias for twin engine designs because of the fail safe engine loss over water issues. All of the aircraft these designs are to replace; the A-6 and F-15/F-14 aircraft have twin engines. Early sizing studies indicated that the aircraft would be very large and would require two engines to keep the engines within the airflow ranges seen for these classes of aircraft. Selection of a common engine arrangement for all concepts would eliminate the confusion of dealing with a mixture of single and twin engine designs in comparison of other design issues.

Airframe integration for Joint Service usage is achieved more efficiently in a twin engine configuration by use of a centerline structural keel to directly carry both launch and arrested landing loads.

Survivability and general safety of flight data show an advantage for the redundancy in both primary and secondary power sources integrated in a twin engine configuration.

#### **F-22 Core Avionics Suite**

The NASA provided technology list had a large number of technologies already utilized in the F-22 avionics suite. Any differences in avionics suite requirements to handle different mission roles will be handled as additions or deletions to the baseline hardware or software of the existing F-22 avionics suite. Improvements to the avionics systems have also been considered.







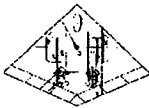
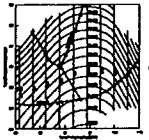
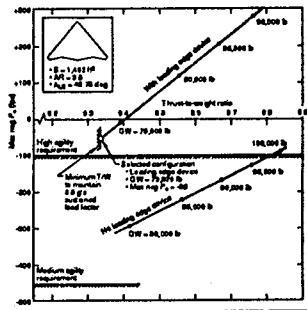

	Observables level	Agility level	Initial configuration matrix	Configuration conceptualization	Aircraft sizing and performance	Final configurations
			<ul style="list-style-type: none"> <li>Assumptions and ground rules</li> <li>Number of engines</li> <li>Number of crew</li> <li>Technology assessment</li> <li>Observables guidelines</li> <li>Subsystem selections</li> </ul>	<ul style="list-style-type: none"> <li>Control effector selection/sizing</li> <li>Conceptual layout/size</li> </ul>	<ul style="list-style-type: none"> <li>Planform selection</li> <li>Engine sizing</li> </ul>	<ul style="list-style-type: none"> <li>Weight and balance check</li> <li>Fuel volume check</li> </ul>
Air-to-ground	Low	Medium	GW = 67,350 lb T/W = 0.7 W/S = 45 psf AR = 3.0 			<b>988-122</b> GW = 73,145 lb T/W = 0.34 W/S = 50 psf AR = 3.5 
	Low	High	GW = 67,350 lb T/W = 0.7 W/S = 45 psf AR = 3.0 			<b>988-123</b> GW = 73,145 lb T/W = 0.34 W/S = 50 psf AR = 3.5 
Multi-role	Low	Medium	GW = 57,750 lb T/W = 0.9 W/S = 60 psf AR = 3.0 			<b>988-118</b> GW = 50,899 lb T/W = 1.1 W/S = 46 psf AR = 3.52 
	Moderate	High	GW = 57,750 lb T/W = 0.9 W/S = 55 psf AR = 2.7 			<b>988-119</b> GW = 48,801 lb T/W = 1.1 W/S = 59 psf AR = 3.97 
Air-to-Air	Low	Medium	GW = 47,700 lb T/W = 1.1 W/S = 55 psf AR = 3.0 			<b>988-114</b> GW = 65,230 lb T/W = 1.13 W/S = 46 psf AR = 3.64 
	Moderate	High	GW = 47,700 lb T/W = 1.1 W/S = 70 psf AR = 3.5 			<b>988-115</b> GW = 59,549 lb T/W = 1.13 W/S = 58 psf AR = 3.8 

Figure 4.1 Configuration Evolution

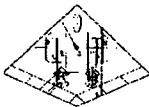
## Observable Features

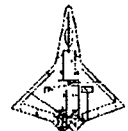
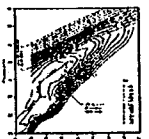
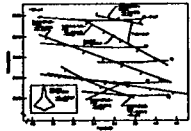
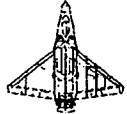
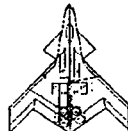
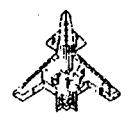
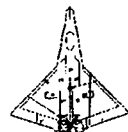
Moderate levels of observability, as a general classification regarding both RF and IR signature characteristics, is taken to describe vehicles as similar to the YF-22/YF-23 airplanes, or better, in certain frequency bands.

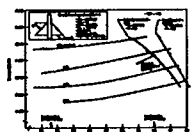
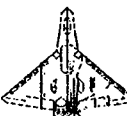
Low observable levels for both RF and IR signature characteristics are considered to place a vehicle in the region approaching B-2 levels.

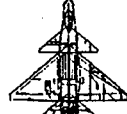
In order to achieve the general levels directly three primary configuration items have been established for integration within each air vehicle type.

- **Internal Weapons Carriage** - mission loads are carried within the vehicle basic moldline in dedicated weapons bays. Stores are either ejection released or rail launched from these bays. No conformal or external carriage is considered for the primary/sizing mission specified.
- **Tail Surfaces** - directional control traditionally obtained by use of either vertical or canted fin/rudder, or all moving surfaces, have been eliminated from consideration because of their inherent penalty to signature reduction. Additionally, in the high alpha combat flight regimes, directional control effectiveness becomes degraded rapidly.

In this study each air vehicle type incorporates a thrust vectoring rotating nozzle to provide yaw control power by direct control of engine exhaust. Supplementary directional control is obtained by use of Yaw Vane panel pairs integrated into the forward body surfaces fairing into each nozzle.

Additionally, Yaw Vane pairs are provided on the lower aft vehicle surface for use during those inflight phases requiring increased directional control or side force moment generation.

The combination of a thrust vectoring rotating nozzle with co-located Yaw Vane panels results in a unique method of generating sufficient directional control power throughout the flight envelopes and maneuver range of these vehicles at greatly reduced signature levels.

- **Vehicle Shaping/Arrangement** - Moderate observables levels are to be obtained by developing local body maximum half breadth slopes at or near to forty (40) degrees relative to the horizontal reference plane. Wing body integration will be blended to avoid corner reflector conditions. Where wing and tail, or wing and canard combinations are employed for agility the approach taken will be to minimize platform edge mis-alignment or breaks and dissimilar sweep angles. Where these conditions exist, observability levels will degrade as a direct result of obtaining the required agility metric.

The approach to obtaining low observables in a configuration type will employ aligned edges with minimum breaks or dissimilar angles. However, in each air vehicle type, agility performance metrics will be the dominate consideration.

In the case of Air Interdiction type, where the prescribed mission requires a long distance penetration segment, the configuration will be based on an all flying wing design concept employing long straight edges to the maximum extent possible with the objective of achieving lower observability at the lower frequency threat levels.

## Control Effectors Selection

Selection of control effector devices for each air vehicle type was based on the following listing. These devices are combined/integrated with a particular configuration concept to generate the required control forces. Most of these devices are well known and used widely in actual application,

Yaw axis thrust vectoring is included here as a primary control effector which operates synergetically with the Yaw Vane panels to produce directional/side-force moments, or alone as speed brakes.

### Effector Type

### Application/Usage

- |                            |  |
|----------------------------|--|
| • Yaw Axx Thrust Vectoring | • Directional control with $\pm 45$ degrees deflection range<br><br>• Side force moment generator  |
| • Yaw Vanes                | • Pop-up surfaces integrated with Yaw axis rotating nozzle<br><br>• Provide supplementary Yaw axis control power, side force moments, or act as speed brakes when deployed as full pairs |
| • Canard-Lifting           | • All-moving surface deflected symmetrically for pitch and asymmetrically for roll control   |
| • Horizontal Tail          | • All-moving surface deflected symmetrically for pitch and asymmetrically for roll control   |
| • Elevons                  | • Single panel used for lateral/pitch control<br><br>• Split panels used for lateral/pitch and asymmetrically for side force or Yaw moment generation.                                   |
| • Leading Edge Slats       | • Increased lift for maneuver conditions   |
| • Trailing Edge Flaps      | • Increased lift for maneuver/field performance  |



## 4.2 Carrier Suitability Impact of Aircraft Designs

Carrier suitability is clearly the overriding requirement of any aircraft design operating from an aircraft carrier. Operations from Navy Aircraft carriers at sea impose a broad range of geometry constraints, and performance requirements on aircraft designs. The issues of carrier suitability involve all design disciplines including support functions such as ILS, maintainability, and supportability. Carrier suitability has many interwoven effects such as launch/recovery/basing geometry constraints, maintainability access, weapons loading, and landing gear geometry for efficient structure and good deck handling. Control effector sizing designed to trim the high lift system while maintaining adequate dynamic margins is also an important design issue.

### Geometric Limitations

The catapult launch imposes hard limits on the overall length of the aircraft and the minimum height above the ground for the fuselage and any of its externally carried stores such as centerline tanks and weapons.

The tight quarters of the flight and hanger decks, the large number of operating aircraft, personnel, and support equipment contribute to a maze of Navy unique design requirements.

The elevator clearances require that hinges for folding wing aircraft be employed with power actuation.

The hanger deck imposes a height limit to the vertical tail and wings in the folded position to 17 feet.

### Weight Limitations

The aircraft takeoff weight, fully loaded, is limited the 90,000 lb capability of the C-13-1 catapult. However, to efficiently conduct flight operations, the elevators must support two mission ready aircraft, one tractor and the associated personnel. The fueled aircraft without stores must therefore not exceed 54,500 pounds, using the new TA-12 tractor.

The landing weight, with reserve fuel and retained weapons, is limited to the 65000 lb limit of the Mk7-MOD3 arresting gear.

### Landing Gear Design

The landing gear strength and stroke length are driven by the impact loads of arrested landings. The weight penalty applied to the main gear to adjust the Air Force version of the configuration to the joint service configurations amounts to 37.8% to the main gear weight.

A stored energy nose gear is assumed during this study. The stored energy nose gear uses the vertical reaction of the nose gear with the deck during the deck run on the catapult power stroke to impart both an optimum pitch rate and attitude to minimize launch flyaway airspeed. The nose gear must be fully casterable for roll back after arrestment. The dual tire nose gear must also have built-in tow and holdback fittings for catapulting. The resulting weight penalty used to adjust from Air Force landing loads to joint service landing loads results in an increase in nose gear structural weight of 63 percent over its Air Force counterpart. See figure 4.2.

### Wing and Fuselage Structural Re-Inforcement

Structural adjustments to the wing structure to accommodate landing gear punch loads and folding mechanism adds 17.5 percent to the wing structural weight. The fuselage structure is increased 5 percent to handle the loads of the tail hook and nose gear during landing.

### Engine Installation

Engine air intakes must be placed to avoid ingestion of steam on the catapult stroke.

# Historical Weight Trends

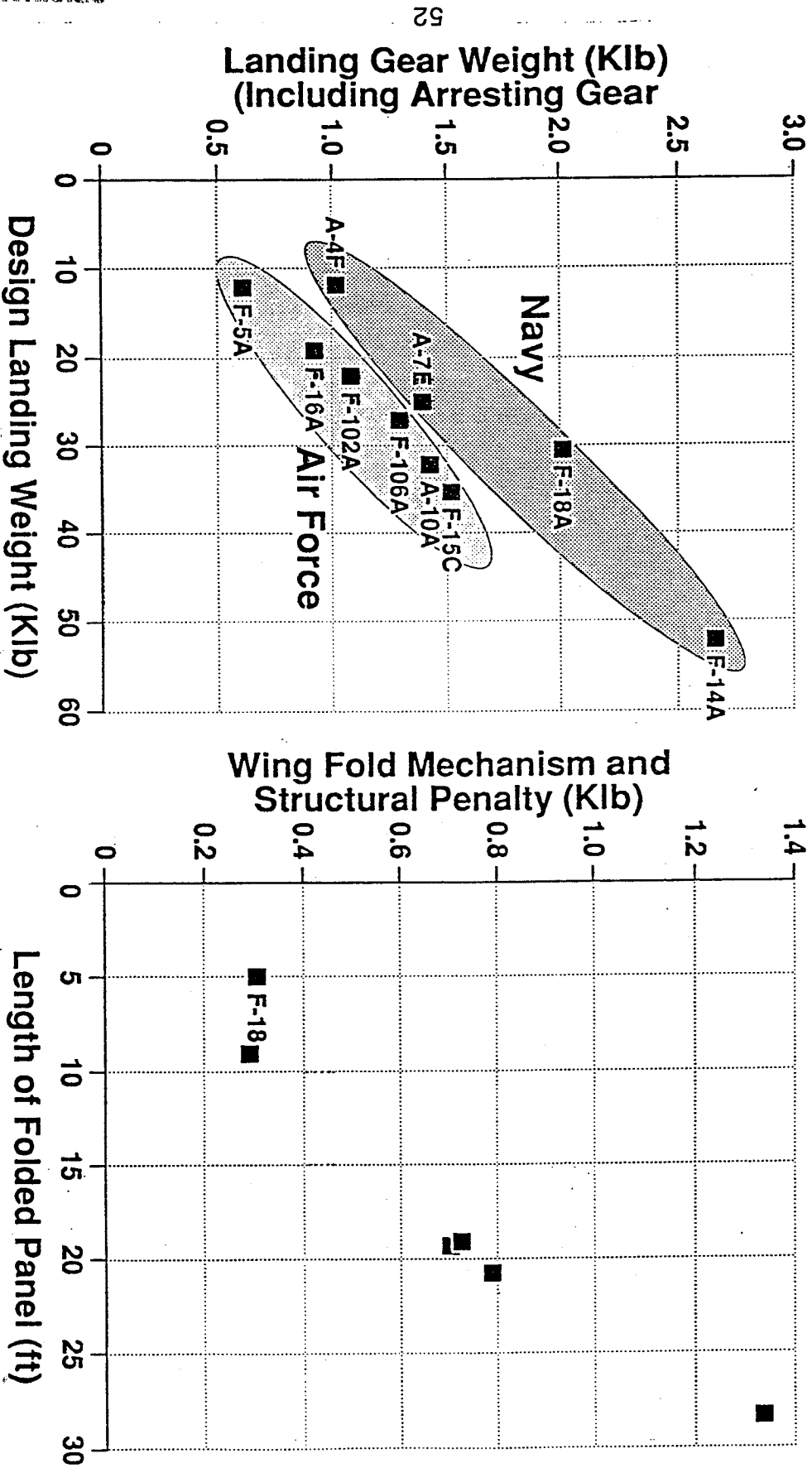

Figure 4.2

Engines must be located to allow complete removal and replacement without cranes, while wings are folded, in the hanger deck area.

#### Weapons Loading

Weapons must be loaded while wings are folded, without the use of cranes or ladders. Suspended weapons must be high enough above the ground to clear the catapult shuttle and to avoid deck impact in a wing-low arrested landing.

#### High Lift Devices

The wing designs used have historically used high lift flap systems and other devices to allow safe low speed flight after catapult release, fully loaded.

The wing must also provide low lift for safe go around without touchdown on an aborted landing.

#### Support Equipment

Steps or ladders for entry of the crew must be built-in to minimize deck clutter safety hazards on the flight deck and the hanger deck.

Fueling and routine servicing or rearming must not require platforms or external hoists, only dollies.

#### Environment

High sea-states and low-visibility/night operations demand an aircraft with superior stability and control characteristics to accomplish the required high precision flight path control necessary to routinely accomplish recovery safely.

#### Landing Recovery

Carrier approach speed, approach angle-of-attack, stall margin, vision angle, pop-up maneuver, longitudinal acceleration, thrust response, single engine rate-of-climb analysis are all inherent analysis capability within the Fighter Aircraft Sizing Tool (FAST) aircraft sizing and performance code. The carrier suitability analysis modules in FAST parallel the conceptual level methodology of the NAVAIR CAT and APR codes. In addition, FAST is capable of determining a rough order estimate of carrier spotting factor.

The main driver in carrier recovery is the requirement for significantly lower airspeeds during approach and arrestment. This drives the designer to maximize the use of high lift recovery devices. Use of such devices frequently conflict with the need to use thinner, cleaner airfoils optimized for high-speed up and away flight. Safe recovery of Navy aircraft force the design to emphasize low speed stability and Control regions driving the size of the horizontal surface up. Naval aircraft become a balance between the uncompromising need for safe flying qualities at the low speed end of the flight envelope while minimizing maneuvering and performance penalties at the high speed end.

#### Catapult Launch

Catapult launch analysis determines the minimum safe launch airspeeds while maintaining acceptable flight characteristics in this low altitude, high angle-of-attack regime. Approach and landing requires the slowest possible approach airspeeds while retaining the performance and handling qualities need for precision glide slope control. Keeping approach airspeeds low results in reduced ship's operating speed and thus enhances the operational flexibility of the aircraft carrier.

Catapult launch presents the danger of operating too close to the aircraft minimum control airspeed. Since catapult end-speed is constrained by catapult performance, the requirement for a 10% stall margin at the end of the deck-run and an angle-of-attack margin 20% below stall drives the designer to maximize  $C_{lmax}$  in the takeoff configuration. The requirement of a 500 foot/minute minimum rate of

climb in the event of an engine failure and a fly-away longitudinal acceleration greater than 0.065 gs imply the need to maximize L/D beyond that required for an equivalent Air Force Aircraft.

The naval aviator has to be able to see the carrier during approach at relatively high angle-of-attack. The location of the pilots eye and shape of the aircraft nose must accommodate this approach angle-of-attack. A 3.5 degree glideslope mandates an 18. degree over-the-nose vision angle for carrier approach.

#### Wave-off and Bolter

Wave-off and bolter present further constraints on the propulsion and drag-brake systems, which in turn directly affect stability and control through rapidly occurring, transient changes accompanying typically large thrust commands. The major challenge is obtaining quick engine response, coupled with an adequate amount of pitch control.

#### Combat Maneuvering

Up-and-away maneuvering requirements have traditionally been more stringent for the Navy because of its insistence of utilizing as much of the flight envelope originally designed into the aircraft. The Navy expects their pilots to fly to the edge of the envelope and consequently drives the designer to provide Level 1 flying qualities to the maximum limits of the operational envelope. This has a number of implications to departure resistance, angle-of-attack limiters, and maneuver devices.

The Navy requires high departure resistance at high angle-of-attack sufficient to prevent loss-o control while maneuvering close to and possibly through the flight envelope where aerodynamic control traditionally begins to diminish. The Air Force will typically accept limiters to avoid approaching CLmax boundaries throughout the maneuvering envelope. The Air Force F-16 employes an angle-of-attack limiting schedule which shrinks the left boundary of the energy maneuverability envelope significantly beyond corner speed. Unique maneuver devices normally found on naval aircraft to ensure maximum maneuvering performance over a full flight envelope. These devices usually take advantage of an already unique low speed, high lift system such as the maneuver flap or slat.

### 4.3 Designing for Agility

This section discusses studies conducted to relate the agility metrics to design considerations (figure 4.3-1). Before the design studies could be carried out, a framework of design guidelines was established. Aerodynamic characteristic needs were derived from the metrics and the design guidelines. Techniques were formulated to bridge the gap between metrics/guidelines and effector sizing. Finally, this approach was used to size effectors on three different airplane configurations: one medium agility and ten high-agility concepts.

Agility metrics are defined in figure 4.3-1 below. The agility performance of conceptual configurations is discussed in terms of aerodynamic forces and moments required to meet these performance goals.

#### 4.3.1 Agility Metrics

##### Maximum Negative Specific Excess Power

Maximum negative specific excess power ( $P_S$ ) is a metric that was created to describe the energy loss of an aircraft while executing an unsteady turn. This metric attempts to quantify an aircraft's potential for losing energy by measuring the minimum (or maximum negative)  $P_S$  (rate of change in specific energy) achieved during a maneuver. Maximum negative specific excess power corresponds to an aircraft's maximum instantaneous turn rate capability

Energy exchange during combat is a combination of speed loss (kinetic energy) and/or altitude loss (potential energy) and depends on the controls applied by the pilot or flight control system and the aircraft's aerodynamic characteristics. The classical approach to combat management is to minimize energy loss during combat.

Maneuver employed to attain the maximum instantaneous turn rate consists of using the elevator to increase the aircraft angle-of-attack and, in some cases, the application of aileron, rudder, speed brakes, and maneuver flaps. Although a reduction of thrust would result in a reduction of the net axial force on the aircraft (and thus a reduction of specific excess power) this technique is not normally used. Engine response time is of the same order of magnitude as the time needed to achieve the desired conditions. Furthermore, the capability to gain speed following the turn would be seriously compromised.

Computation of the maximum negative specific excess power is identical to specific excess power performance. This is addressed in section 5.0 along with the maneuver performance requirements..

##### Time-to-Bank and Capture 90-Degrees

In air combat, the offensive pilot attempts to achieve target acquisition. To achieve his objective of destroying the enemy, the pilot must successfully deploy his weapon, which requires aiming or locking-on. To lock-on or aim a weapon the pilot must precisely control his aircraft. During this phase, the defensive pilot tries to evade the offensive pilot's attempt by jinking of-of-plane and changing the battle geometry. The offensive pilot has to reacquire the target and track sufficiently to deploy his weapon. The cycle of acquire, jink, reacquire, jink, etc., is characterized by the offensive pilot's banking with the intent of capturing a specific bank angle as determined by the jinking maneuver of the defensive participant. Time-to-bank to and capture 90 -degrees was chosen as an agility metric because it quantifies an aircraft's ability to offensively reacquire an evading target.

Airplane roll performance is measured with respect to a single-degree-of-freedom system. While the pilot may use the rudder peddles to slip the airplane and increase roll acceleration, the designer is not permitted to take advantage of this maneuver. Indeed, for a class IV airplane, automatic turn coordination is already required, insuring that the airplane behaves as a single-degree-of-freedom system in roll. Therefore, the performance of the roll control system can, to a great extent, be described by two terms: maximum roll acceleration and the roll time constant. Maximum roll acceleration is proportional to the roll control moment available. Roll time constant is related to the airplane roll damping. Roll damping can be influenced by roll rate feedback if required. Much research

### AIR TO AIR

#	Flight Condition	Agility axis	Agility Metric	Medium Agility Design Goal	High Agility Design Goal
1	M = 0.6 Hp= 15,000 Ft qbar = 301 psf	* pitch maneuver agility	The airplane will have a specified value of deceleration at the maximum instantaneous turn rate. Deceleration is given in terms of specific power. Load factor to be greater than 5.5 g's	Ps = -450 fps	Ps = -800 fps
2	√	Pitch angular Agility	Minimum nose down angular acceleration at the design critical alpha. (taken as the alpha 'pinch point')	-.15 Rad/Sec <sup>2</sup>	-.35 Rad/Sec <sup>2</sup>
3	√	Pitch envelope agility	Maximum departure free alpha	40 Deg	70 Deg
4	√	Roll Agility	Time to roll and capture . Start at $\phi = -45$ Deg. Then roll thru 90 deg and capture $\phi = 45$ Deg. (Adequate yaw control power to roll around the velocity vector is required.)	2.5 Sec	1.5 Sec
5	√	Lateral agility	Maximum lateral acceleration with the wings level. Max maximum load factor	Ny = 0.4 g's	Ny = 1.0 g's

\* Evaluation is shown in the performance section

Figure 4.3-1. Agility Design Goals (sheet 1 of 2)

### AIR TO GROUND

#	Flight Condition	Agility axis	Agility Metric	Medium Agility Design Goal	High Agility Design Goal
1	V= 450 KEAS M = 0.68 Hp= SLS qbar = 686 psf	* Pitch maneuver agility	The airplane will have a specified value of deceleration at the maximum instantaneous turn rate. Deceleration is given in terms of specific power. Load factor to be greater than 7.5 g's	Ps = -450 fps	Ps = -800 fps
2	√	Pitch angular agility	Minimum nose down angular acceleration at the design critical alpha. (taken as the alpha 'pinch point')	-.15 Rad/Sec <sup>2</sup> (not applicable)	-.35 Rad/Sec <sup>2</sup> (not applicable)
3	√	Pitch envelope agility	Maximum departure free alpha	na (Alpha limiter at 0.9 CL max)	na (Alpha limiter at 0.9 CL max)
4	√	Roll agility	Time to roll and capture . Start at $\phi = -45$ Deg. Then roll thru 90 deg and capture $\phi = 45$ Deg. (Adequate yaw control power to roll around the velocity vector is required.)	1.5 Sec	1.0 Sec
5	√	Lateral agility	Maximum lateral acceleration with the wings level. At load factor = 1.0 g's.	Ny = 1.2 g's	Ny = 2.0 g's

\* Evaluation is shown in the performance section

Figure 4.3-1. Agility Design Goals (sheet 2 of 2)

has been done to determine optimum values for roll acceleration requirements and time constants. Specifying a minimum roll acceleration capability and time constant, along with a control rate input, results in a unique roll angle time history. Frequently, specifications are expressed as the time required to roll through a certain roll angle. For a class IV airplane at combat flight conditions, this is usually 90 degrees in 1 second. It is the task of the preliminary design engineer to ensure enough roll control to meet this specification. Adequate roll control must be designed into the airplane during preliminary design. The designer has some control over the time constant through roll rate feedback.

#### Maximum Nose-Down Pitch Acceleration

Many times in air combat the roles of the offensive and defensive pilots are reversed. When an offensive pilot is faced with role reversal his objective changes from that of destroying the enemy to not being destroyed. A frequently successful defensive tactic is to disengage, break off the battle, and return to safe air space. As the defensive pilot attempts this action, the offensive pilot will continue his pursuit. The success of the defensive pilot depends on his ability to transition from an engagement mode characterized by high load factors and high turn rates to an escape mode characterized by high longitudinal accelerations to maximize the separation distance. This maneuver requires the pilot to unload his airplane as quickly as possible and achieve a minimum drag flight angle-of-attack. Maximum nose-down pitch acceleration was chosen as an agility metric to quantify the aircraft's transition from a highly loaded air combat flight condition to an escape or maximum longitudinal acceleration condition.

#### Maximum Achievable Trimmed Angle-of-Attack

Modern air combat research has shown that high angle-of-attack or post-stall flight may provide a tactical advantage on both offensive and defensive aerial engagements. In an offensive mode the pilot's ability to turn at higher turn rates with smaller turn radii provides him with the option to more quickly achieve shot opportunity by out-maneuvering his opponent. In a defensive mode high-angle-of-attack capability can be utilized by a pilot to bleed energy more quickly, thus forcing the offensive pilot to overshoot and providing role reversal. In either case high-angle-of-attack capability will be utilized by a pilot only if the airplane remains controllable and has good handling qualities. Maximum Achievable (Departure-Free) Trimmed Angle-of-Attack was chosen as an agility metric to quantify an aircraft's ability to utilize the post-stall flight regime.

#### Maximum Lateral Acceleration

It has been proposed that an aircraft's ability to laterally translate its position may be of significant tactical advantage. In a real engagement this ability may provide useful defensively as a jinking maneuver. However, this characteristic may be of even greater importance in a ground attack mode. Typically, high value ground targets are attacked in a manner requiring a single pass or flyby for each target. An airplane with substantial lateral displacement capability may be able to attack a target, laterally displace its position, acquire and attack a second target on the same pass. Maximum lateral acceleration was chosen as an agility metric to quantify an airplane's ability to attack multiple ground targets on a single pass.

Before discussing the scope analysis a few words must be said about how the agility is used and its importance. Tactics using flat turns were flight tested by the USAF in 1983 on the AFTI/F-16. The recommendations from that testing (more than 15 unique flight modes were tactically tested) singled out flat turns as important for new airplanes.

The maneuver was best for a/g and not as good for a/a. It was best for strafing runs and delivering dumb bombs. Delivery of smart bombs may not be an agility issue. The same is true for a/a. The flat turn would be best for a/a gunnery and not guided a/a missiles.

Flat turns made the airplane more lethal and at the same time more survivable. The use of flat turns is complex. For example, the optimum dumb bombing technique combined classical roll and pitch for gross heading changes with flat turn for small changes. The pilot used roll stick to quickly get the piper in the vicinity of the target. Remaining directional errors were removed with flat run rudder



The maneuver was best for a/g and not as good for a/a. It was best for strafing runs and delivering dumb bombs. Delivery of smart bombs may not be an agility issue. The same is true for a/a. The flat turn would be best for a/a gunnery and not guided a/a missiles.

Flat turns made the airplane more lethal and at the same time more survivable. The use of flat turns is complex. For example, the optimum dumb bombing technique combined classical roll and pitch for gross heading changes with flat turn for small changes. The pilot used roll stick to quickly get the pipper in the vicinity of the target. Remaining directional errors were removed with flat run rudder pedals. This combined technique reduced exposure time to hostile fire and increased bombing accuracy. Savings of 0.90 second on a 3 to 4 second final dive were routinely demonstrated. Strafing was markedly improved. On a single pass there was time to strafe more than one target.

It was important to note that a finding was that flat turns were used only in the case of small (5 degree) heading changes. Beyond about 5 degrees, it was best to roll.

The conclusion is that flat turns are an important flight mode as long as guns and dumb bombs are an important part of the inventory.

#### 4.3.2 Preliminary Design Guidelines

Design guidelines were established along with assumptions necessary to provide a realistic preliminary design framework for the study. The following issues are individually discussed in subsequent paragraphs.

- a. Departure Free Flight Operations.
- b. Airplane Weight and Balance.
- c. Finless S&C Design Criterion
- d. High Alpha Aerodynamics
- e. Thrust Vector Consideration.
- f. Moment of Inertia Consideration.
- g. Engine Failure Consideration.
- h. Axis System Consideration.
- i. Multi-Axis Simultaneous Control Consideration.

#### Departure Free Flight Operations

No studies to define ingredients to make an airplane departure free were made. It is felt that none of the currently available evaluation criteria has proven to be necessary and sufficient to guarantee departure free flight operations. Consequently, it is assumed that a smart and fast digital FCS/VMS combined with active thrust vectoring for pitch roll and yaw control would make the airplane departure free. It is believed that departure free flight operations will result from effectively used thrust vectoring control power.

#### Airplane Weight and Balance

The designs shown in this report have been balanced. The balance of each configurations is based on huiristics that establish location of the aft limit of cg. Once the aft limit is established then the weight of engines fuel and subsystem equipment are adjusted. Often the wing planform must be adjusted to get a satisfactory cg location. These huiristics have evolved from comprehensive studies such as ATF, MRF AX, and ASTOVL. The assumptions used are listed below.

All the design rules are based on the location of the aerodynamic center. This location is predicted from simple and rapid vortex lattice analysis. This process is routine in Boeing preliminary design.

Type Airplane	Aft cg Limit Location
Flying wing	On the ac
Aft Tail	5% mac aft of the ac
Canard	At the 'canard off' ac

These rules are based on recovery from any alpha with only aerodynamic control effectors. Consequently, the airplane is not dependent on pitch thrust vectoring for safety of flight.

#### Finless Airplane S & C Design Criterion.

The S & C design criterion for finless airplanes is as follows: The airplane shall be recoverable from a beta upset with the use of **only** aerodynamic control effectors. This means that the airplane then can be safely flown in spite of a defective thrust vectoring system.

A finless airplane must have certain special characteristics. These characteristics are listed below.

- a. Large yaw vectoring range (20 to 45 deg) with gas angle rates of from 80 to 100 deg/sec
- b. Fast differential thrust magnitude that produces significant levels of yaw control.(even at low power settings).
- c. An alternate source of yaw control that is independent of the engines. (Yaw vanes and B-2 type split flaps)
- d. A means of controlling the thrust magnitude for flight conditions when the airplane at trim requires low throttle settings. (Aero speed brakes and/or in-flight thrust reversing can be used .)

Items a. and b. are for normal flight operations when the airplane is stealthy. Items c. and d. are for abnormal conditions when flight safety, not stealth, is the main consideration.

#### High Alpha Aerodynamics

Methods to predicting forces and moments for flight conditions at high angle of attack are not reliable. This short coming was overcome by predicted high alpha data based on empirical data or based on data extrapolations from wind tunnel test of similar configurations.

#### Thrust Vectoring Considerations

Thrust vectoring philosophy emphasizing yaw vectoring was adapted early in the study. This allowed two unusual features to be considered during development of the configurations:

- a. The configurations could be fin-less.
- b. The configurations could have widely separated engines.

The thrust vectoring mechanization selected for this study is unique and innovative. The thrust vectoring has 45 degrees capability. The vectoring nozzle when exhausting over flap can produce pitch. A two-engine arrangement could produce moments for pitch roll and yaw control. This represents a different philosophy from current designs. 'Now' airplanes emphasize pitch vectoring of 20 to 25 degrees with no yaw vectoring or multiaxis axisymmetric nozzles with limited authority (10 to 12 degs).

Thrust vectoring is a nozzle term. It is the gross thrust that is being vectored and not the net thrust as used in the performance calculations. The gross thrust is often quite different from the static thrust and can be larger or smaller than the static thrust. The breakdown of net thrust into gross thrust and ram drag is tabulated. The data is for a unity engine at power setting 1.0. Engines are scaled from the data below.

Case #		1	2	3
Flight task	-	Base	A/G	A/A
Mach	-	0	0.68	0.60
Altitude (feet)		0	0	15,000
Power Setting		1.0	1.0	1.0
Gross Thrust (pounds)		20,966	28,899	16,398
Ram Drag (pounds)		0	8,574	4,266
Net Thrust (pounds)		20,966	20,325	12,132
Fgross/ Fgross sls	-	1.0	1.38	0.78

### Moment of Inertia Considerations

Moments of inertia have been estimated using empirical data. These moments of inertia are defined in the body axis. These data are predicted for each airplane.

Pitch, roll, yaw and product of inertia values were estimated using historical data on actual airplanes which have significant parameters very similar to the ADS "design point" configurations. Values of radii of gyration in percentages of wing span, body length or an average of the two were determined from existing aircraft which have similar wing-span-to-body-length ratios, engine number and engine locations. The percentages were then applied to the ADS airplane(s) dimensions and the inertia data generated at the combat weight conditions. In some cases the statistical values were amended to account for specific peculiarities of the design and, therefore, improve the validity of the estimates.

### Engine Failure Considerations

Powerful yaw vectoring allows the engines to be far apart. This design degree of freedom is not usually available. In case of one engine out the operating engine can be vectored so that the nozzle force acts through the cg. This means that the mission can be terminated and the airplane can safely return to the base.

### Axis System Considerations

Forces and moments in both dimensional and non-dimensional form are given in the stability axis system. Analysis in the stability axis system is the standard at this division of The Boeing Company. Conversion of inertias to the stability axis system is routinely done. Analyses shown in this report is done in the stability axis system.

### Multi Axis Simultaneous Control Considerations

Agility metrics are defined for single axis. There is no intent to design the airplane for simultaneous application of 100% of control power to meet all the metrics at once. The control power definitions are for a single axis based on a 1-DOF analysis.

Obvious trim and/or cross axis coupling is considered. Simultaneous control activity in several axis at once is normal for a maneuvering airplane. For example, roll around the velocity vector at high alpha requires adequate moments to null the inertia coupling and aerodynamic coupling to both pitch and yaw axes. Hence, there would be control activity in three axis.

The airplanes have been reviewed in a cursory fashion to ensure that there is adequate control power for realistic levels for simultaneous control. For the roll example; If flaperons are used for three axis (roll, pitch, and yaw) then there would be a separate allocation of span for simultaneous roll, pitch, and yaw; if the full available span is used to meet the roll metric, the airplane would have a fatal fatal flaw.

### 4.3.3 Method Developments

#### 4.3.3.1 Time to Bank and Capture 90 Deg

Design of the roll control system should be approached as a single degree-of-freedom roll about the velocity vector. Military specifications do not allow the designer to take any credit for roll due to sideslip. Coordinated flight must be maintained during roll maneuvers. Also an important part of designing the airplane consists of ensuring that the vertical tail and ruder are adequate to hold zero sideslip (coordinated flight) during the roll maneuver. The easiest way to do this is to predict the time history of a single degree-of-freedom roll maneuver and then predict the maximum yawing moments that occurred. The rudder must have adequate control power to balance that yawing moment. The yaw control power required to balance the yawing moment due to roll is a strong function of angle of attack.

Total aerodynamic yawing moment during the coordinated roll maneuver is

$$n = I_{xz} \dot{P} \quad (1)$$

where

$$\begin{aligned} n &= \text{aerodynamic yawing moment} \\ I_{xz} &= \text{product of inertia about the x-z stability axes} \\ \dot{P} &= \text{roll acceleration} \end{aligned}$$

Aerodynamic yawing moment consists of contributions from roll rate, the roll control system, and the rudder. The design problem is to

- a. Size the ailerons, spoilers, etc., so that adequate roll performance is attained. Aileron effects can probably be predicted using linear aerodynamics. Aeroelastic effects and spoiler characteristics are ignored.
- b. Design the vertical tail rudder so that the yawing moment due to roll is balanced out. Notice that directional stability requirements might be more critical than turn coordination with regard to vertical tail size. Also, however, keep in mind that the tail has to accomplish directional stability and turn coordination concurrently and this has important implications when artificial directional stability is used. If, for example, the airplane is artificially stabilized by feeding sideslip to the rudder, the turn coordination signal cannot be permitted to bottom out the rudder.

Roll performance and tail size requirements must be analyzed at several flight conditions. The tail rudder size design point is very likely not at the same flight condition at which the roll control surfaces are critical. For example, the roll control system will be designed to provide a minimum level of roll performance at some point in the combat flight envelope. Roll performance will be higher every place else in the combat flight envelope. Vertical tail and rudder design requirements will be determined by some combination of high angle of attack (high  $I_{xz}$ ) and high roll acceleration, not necessarily the roll performance design point.

Figure 4.3.3-1 was developed from the time-to-bank and capture algorithm developed in reference 1. This chart predicts roll control power required to meet any specified time-to-bank and capture 90 degrees agility metric goal. This figure assumes that the rudder is sized so that sufficient yaw control power is available to balance out the yawing moment due to roll about the aircraft's velocity vector. The figure has dimensional roll damping and roll time as the independent variable and initial angular acceleration as the dependent variable. The rolling moment coefficient required can then be computed from the equation below.

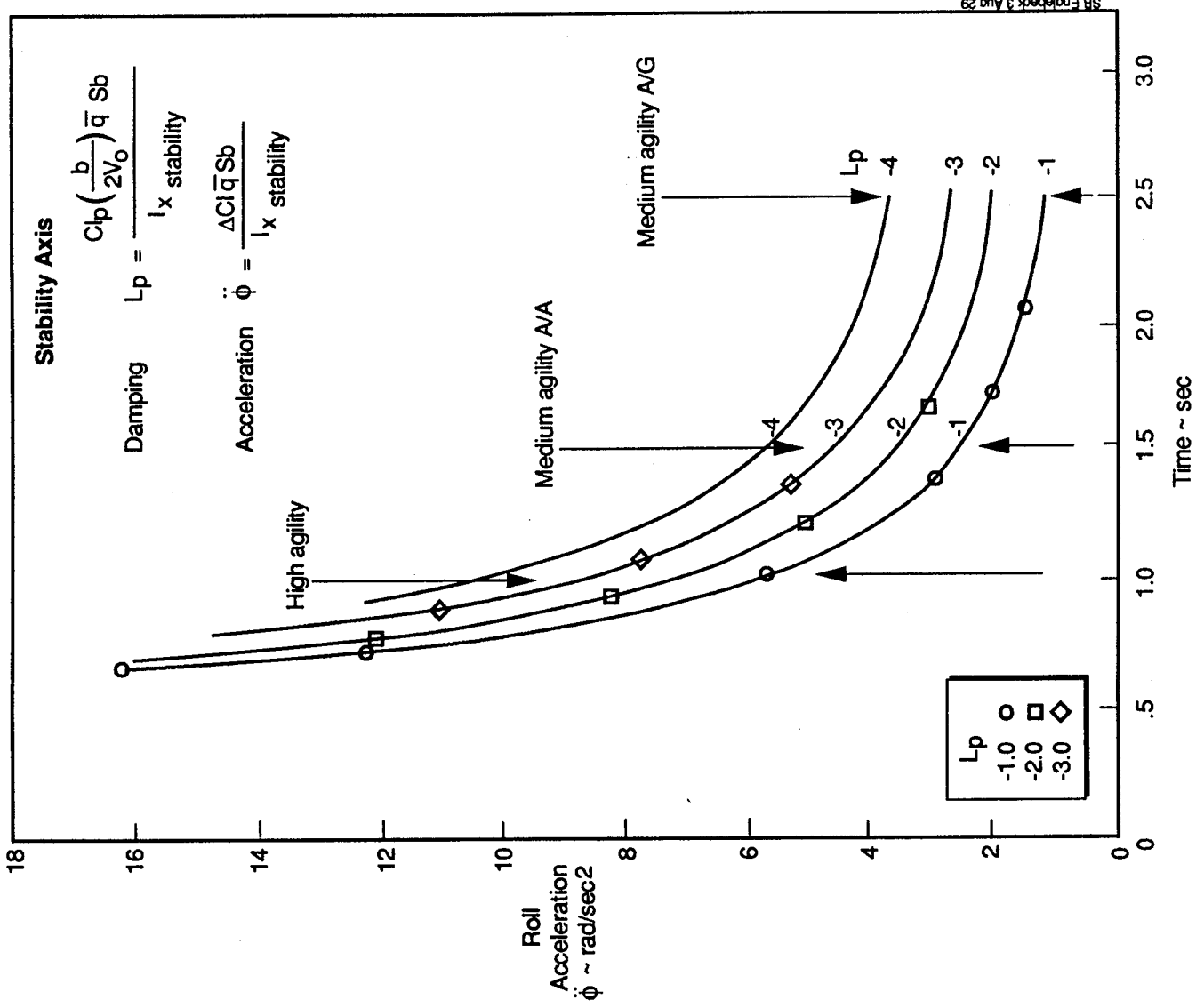

Figure 4.3.3-1. Roll Agility Bank and Capture 90°

$$\Delta C_{l_{required}} = \frac{\theta I_{yy_{stab}}}{S b}$$

**where:**

$\Delta C_{l_{required}}$	-	
$\theta$	- Roll acceleration	rad/sec <sup>2</sup>
$\theta I_{yy_{stab}}$	- Roll moment of inertia about the stability axis	slug-ft <sup>2</sup>
	- Dynamic pressure	lbs/ft <sup>2</sup>
S	- Wing reference area	ft <sup>2</sup>
b	- Wing span	ft
Lp	- Roll damping in the stability axis	1/rad

Figure 4.3.3.1-1 illustrates the exponentially increasing roll control power requirements necessary to realize time to bank and capture 90 degrees in less than 1 second.

#### 4.3.3.2 Longitudinal Control Requirements

Any of the agility requirements relating to longitudinal characteristics need s to be considered at the same time as control surface sizing, c.g. envelope requirements, and optimum landing gear placement. These three issues must be accomplished simultaneously. Regardless of what control devices are selected to accomplish the extreme angle of attack, or what devices are used to meet the pitch acceleration agility goals, the center-of-gravity location is of critical importance. The traditional "X-Plot" shown in figure 4.3.3.2 with the addition of the longitudinal agility requirements is the recommended approach.

The X-chart is a plot of horizontal tail area,  $S_H$ , versus fuselage station, F.S. forward and aft c.g. limits are then plotted. These lines hopefully cross, forming an X. Thus the name: X-chart. For a flying wing design, flap-to-wing-chord ratio might be plotted in place of  $S_H$ . A sample X-chart is shown in figure 4.3.3.2. There is usually a best order in which to place the lines on the X-chart. The first step is to predict aerodynamic center versus tail area. Methods used will depend on the configuration, wind tunnel available, etc. Aerodynamic center will depend on Mach number and dynamic pressure (aeroelasticity effects). During the initial design phase, aeroelastic effects are seldom available. Judgement is needed in order to choose what flight condition the ac curve is predicted for. As the project continues and more and more is learned, ac curves for more flight conditions will appear on the X-chart. In figure 4.3.3.2, two ac curves are shown: one curve represents low speed flight and the other represents a high-speed flight condition. At this point an important decision must be made: What stability level will the airplane be designed to?

The table below lists suggested points of departure for conceptual design location of the aft center of gravity relative to the aerodynamic center. As more information becomes known about the configuration, this information could be updated.

Type Airplane	Aft cg Limit Location
Flying wing	On the ac
Aft Tail	5% mac aft of the ac
Canard	At the 'canard off' ac

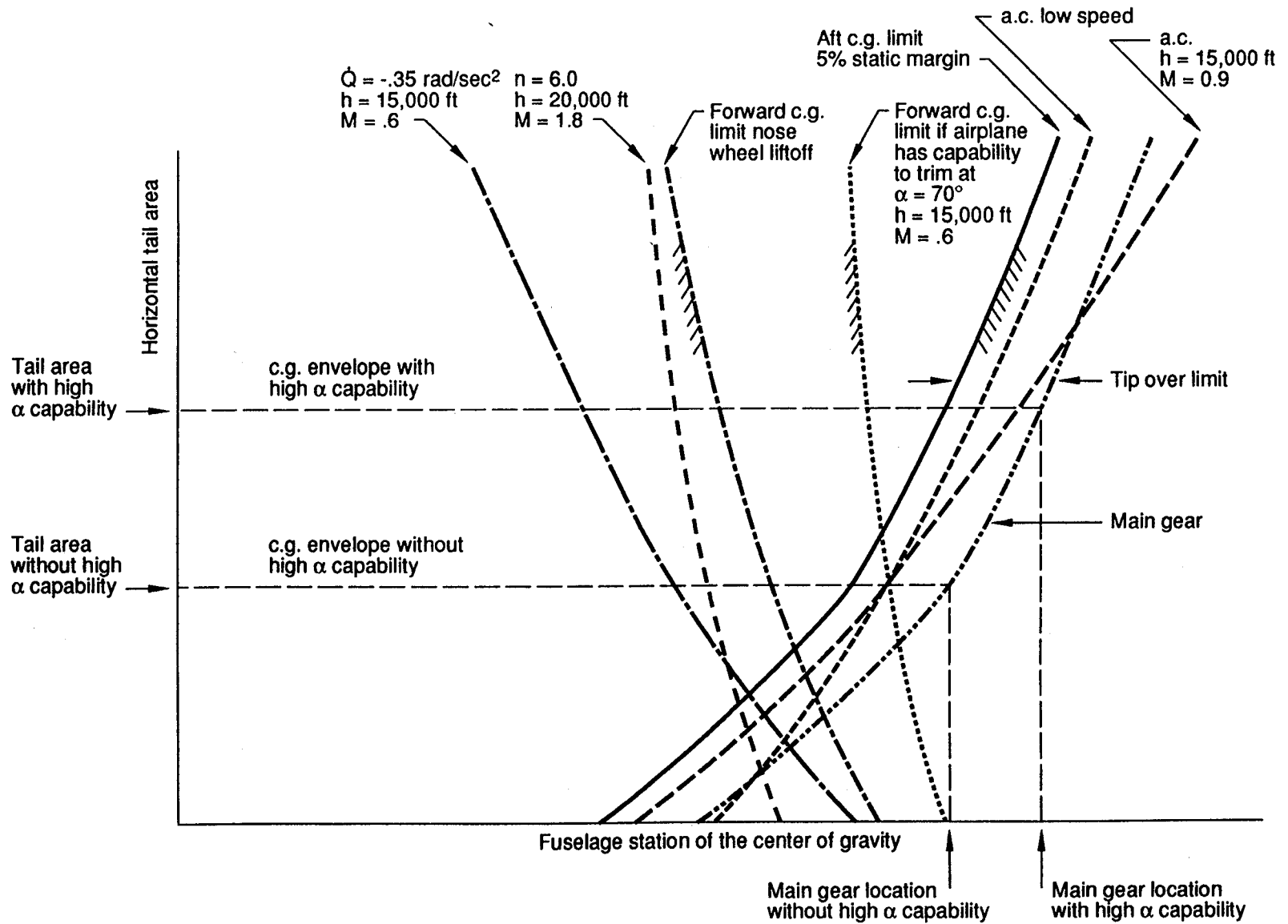

Figure 4.3.3.2.

In the sample X-chart, a conventional stability level of 5% MAC has been chosen. The aft cg limit can be drawn a distance of 5% MAC ahead of the critical ac. Notice that at low tail areas, the low speed ac is critical and at the larger tail areas, the high speed ac is critical. This is not a "probable" result, merely an illustration of one of the things that can happen. Once the aft cg limit is established as a function of tail area, the landing gear location can be put on the chart. Optimum landing gear location will also be a function of tail area. The configurator will determine how far the main gear must be behind the cg to prevent tip-over. We don't want the gear to be much farther aft than this because that aggravates nose wheel lift-off problems. The main landing gear location can now be drawn on the X-chart. It is drawn at the minimum tip-over distance between the aft cg limit. As the design progresses it is usually difficult to maintain the optimum gear location and it will end up a little bit aft of the gear location curve shown on the PD X-charts. This may cost a small increase in tail area depending on how critical nose wheel lift requirements are. The next step is to start putting forward cg limit lines on the chart.

Forward cg limits can result from a number of different requirements. Nose wheel lift off is a common limiting factor, especially jet airplanes with slab tails. Since the cg is always ahead of the main landing gear, it is harder for the tail to rotate the airplane around the gear than the cg. Horizontal  $CL_{max}$  must be determined, or assumed; the cg location is found where the airplane balances on the main gear (nose gear reaction is zero) at the required rotation speed. This is done for a variety of tail areas so cg location can be plotted on the X-chart. The resultant curve is the forward cg limit with regard to nose wheel lift-off. Maneuver requirements can also determine the forward cg limit, especially if the airplane has a supersonic capability. Design requirements might call for certain maneuver capabilities at various points in the flight envelope. They will all have to be analyzed eventually but a little judgement can usually yield the critical ones for PD purposes. As an example, the airplane may be required to pull 6 g's at 20,000 ft and mach = 1.8. This condition is represented on the X-chart by predicting the cg location with various tail areas with the airplane at the specified flight condition. The tail is, of course, loaded to its maximum  $C_L$  in each case. Notice in the example X-chart that this condition did not turn out to be as critical as nose wheel lift-off. So far we have not addressed any of the "special" agility requirements. They belong, however, on the X-chart.

There are some additional X-chart features that should be discussed. The cg envelop must be fitted in between the forward and aft cg limits. Notice that when you do this you don't get to choose the location. If the actual cg envelope is someplace else, the design does not balance and must be re-configured. In the case of conventional airplanes, this is usually easy. The wing just "slides" forward or aft and analysis begins again. In the case of a flying wing, there may not be enough material to move around. Sometimes a flying wing plan form must be abandoned because it cannot be made to balance.

Canard configurations are another special case. Canard area replaces tail area on the vertical axis. As the canard area grows, the ac moves forward instead of aft. All the lines, forward and aft cg limits, lean to the left. There is no guaranteed solution. The cg envelop may have a negative length at any canard size. Our design approach to the canard configuration is to put the cg at the canard off ac. All the aft cg limits are the vertical lines on the X-chart. This, however, results in extremely unstable airplanes with canards of any significant size.

#### 4.3.3.2.1 Minimum Nose Down Pitch Acceleration

First we address the problem of minimum nose-down pitch acceleration using mach = 0.6 at 15,000 ft as a sample flight condition. There may or may not be some special devices to help meet this requirement. In any case the tail should be used to help so pitch-down acceleration will be a function of tail size. Even if the tail is not used as a controller, it will affect the problem through its stability contribution. Assume, for this example, that thrust vectoring is used to aid in pitching down. A constant nose-down pitching moment might be assumed from the thrust vectoring plus an additional increment proportional to horizontal tail area. A horizontal tail  $CL_{max}$  must be determined or assumed for this flight condition. A thrust level must also be assumed. In the sample X-chart, this requirement is not critical and has no effect on the cg limits.



#### 4.3.3.2 Maximum Trimmable Angle of Attack

Determining the forward cg limit for trim at the high angle of attack, ( $\alpha = 70$  degrees for example), the case requires a knowledge of the nonlinear aerodynamics not generally known during the PD phase.

Assumptions for variations in the aerodynamic center location and the magnitude of the normal force enable the evaluation of control requirements for trim at high angles of attack. Figures 4.3.3.2.2-1 and -2 present the nonlinear behavior of normal force coefficient and the center of pressure for the F-16, F-18 and a flying wing configuration. When the normal force is normalized with total projected platform (including the canard and tail) the data collapses along a single trim line. This high-alpha trend can then be faired into the linear low alpha data computed using simple vortex lattice methods.

At angles of attack near 90 degrees, the normal force is equivalent to the drag of a flat plate and has its center of pressure at the centroid of the area of the projected platform.

Prediction of the pitch moment to trim at any alpha is then based on the equation:

$$\Delta C_{m_{trim}} = C_{N_{gross}} (X_{cg} - X_{cp}) \frac{S_{gross}}{S_{ref}}$$

where:

- $C_N$  - Normal force coefficient to total aircraft projected platform as a function of angle of attack
- $X_{cg}$  - Longitudinal position of the center of gravity
- $X_{cp}$  - Longitudinal position of the center of pressure

If thrust vectoring is used, effects of angle of attack on inlet characteristics must also be known. In any case, the tail is probably a factor and the cg location to balance the airplane with all the control efforts at maximum capability will be a function of tail size. An example of how this function might look is shown on the sample X-chart. The curve is shown as a "painful" result. This is done not because of any option regarding trim requirements at high angle of attack, but to illustrate what might happen when unusual requirements are imposed on a design. The X-chart in the sample case shows us that the high angle of attack trim requirement is very expensive in terms of tail size and, therefore, airplane weight and cost. All the other forward cg limit lines are grouped together. If there were no nose wheel lift-off requirement, the tail could be made smaller, but not much smaller. The trim at 6 g's or the pitch acceleration forward cg limit lines are encountered at only slightly smaller horizontal tail areas. Tail size required to meet the high angle of attack requirement, however, is much larger than that required to meet any of the other criteria. In this case, the X-chart is telling us we have a defective design. One solution might be to use some other or additional pitch control devices to accomplish the high angle of attack trim. In any case some re-evaluation is indicated.

#### 4.3.3.3 Maximum Lateral Sideforce

There are two basic approaches to generating the sideforce necessary for a wing's level turn. The first would be a control effector that would develop a sideforce without any sideslip. These devices could be vanes with skewed hinge lines, bomb bay doors with skewed hinge lines, ventral fins, folding wing tips, and landing gear deployment. These devices would have to be located at or near the center of gravity or they would generate a sideslip that would have to be balanced out by some other control device to achieve zero sideslip. Stealth requirements would require the devices be retracted until deployed. Deployable devices that operate at high dynamic pressures (690 lb/ft<sup>2</sup> is the point of interest for the air-to-ground designs) and have substantial structure. Large and structurally strong landing gear have structural placards at 200 to 250 KEAS. The maximum lateral sideforce at zero sideslip approach was therefore abandoned.

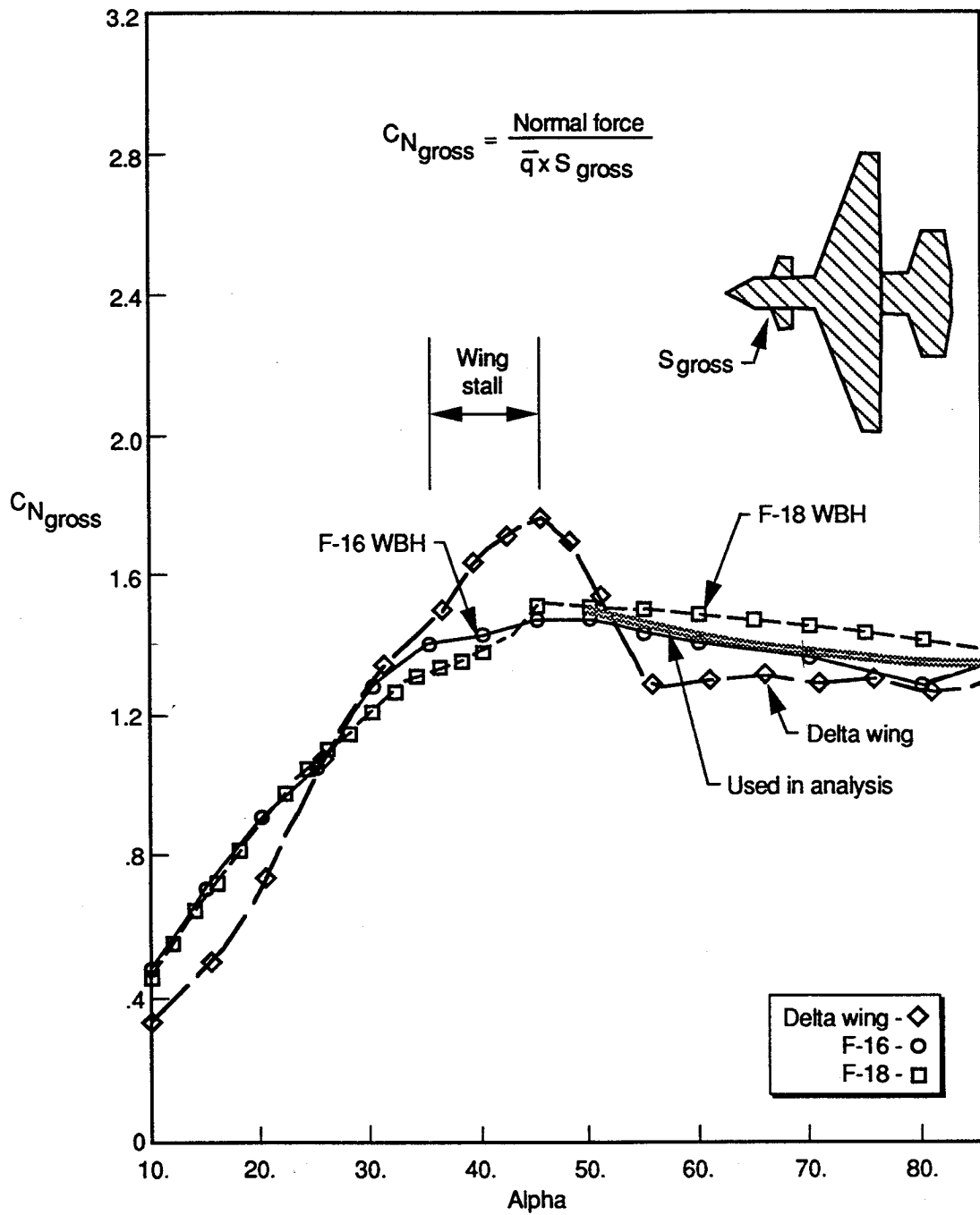

Figure 4.3.3.2.2-1. Normal Force Referenced to Plan View Gross Area

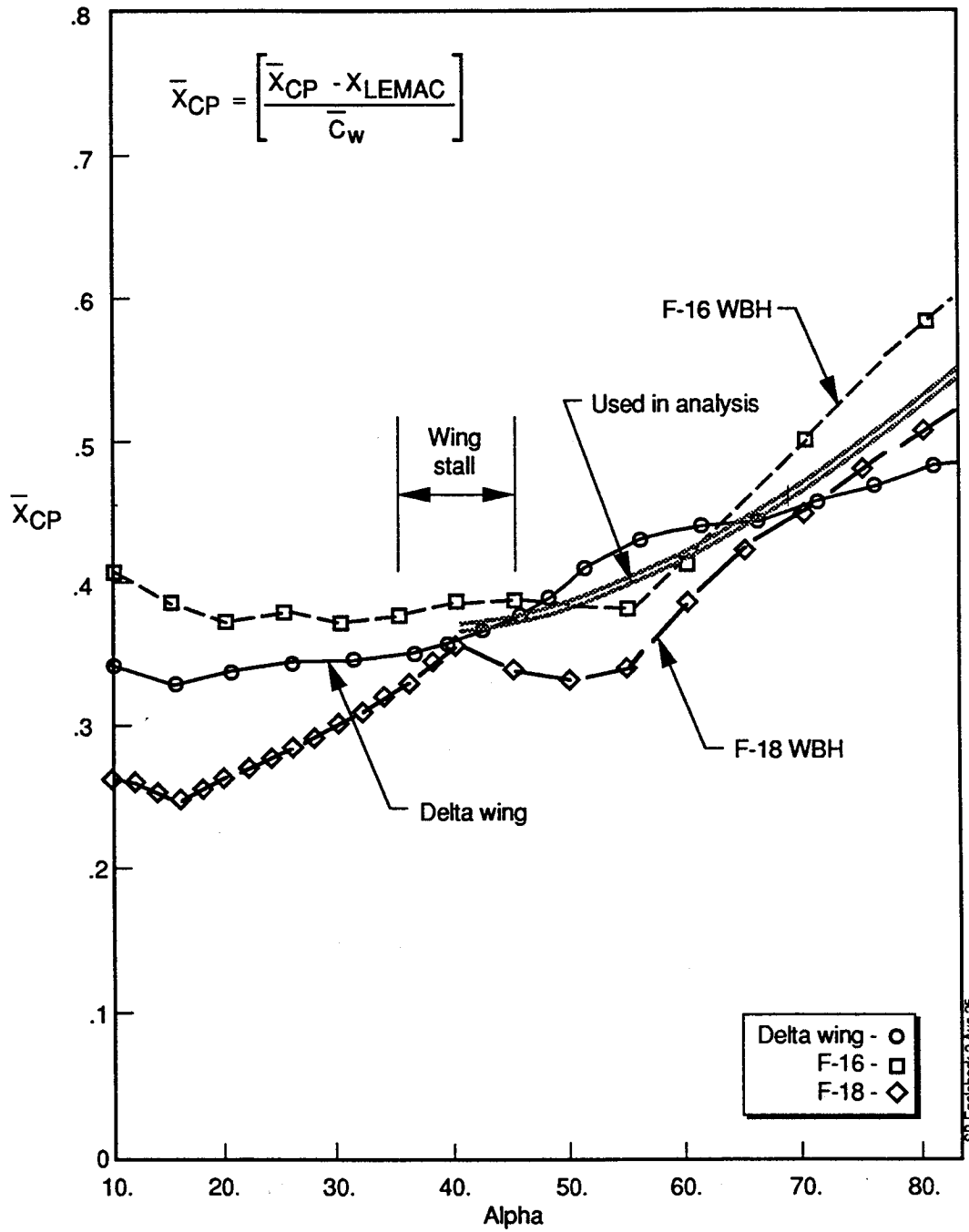

Figure 4.3.3.2.2-2. Center of Pressure Referenced to Plan View Gross Area

The second approach would be to allow 10 degrees of sideslip while maintaining wings level. This is larger than the  $\pm 5^\circ$  effective wing level sideslip angle findings on the AFTI F-16 discussed in section 4.3.1.

The sideforce agility design goal is expressed by the equation:

$$\frac{Y}{q} = n_Y \text{ GOAL} \frac{W}{q} \quad \text{ft}^2$$

And the sideforce generating capability of a control device is given by:

$$\frac{Y}{q} = C_Y \text{ DEVICE} S \text{ DEVICE} \quad \text{ft}^2$$

Assuming a combat gross weight of 50,000 lbs, the sideforce requirements can be computed and presented in figure 4.3.3.3-1.

Mission	qbar	Altitude	Agile level	alpha	n <sub>y</sub>	Y/qbar
Combat Gw= 50,000 Lbs	PSF	FT	-	degrees	g's	Sq Ft
A/A	301	15,000	Medium	30	0.4	67
A/A	301	15,000	High	30	1.0	167
A/G	686	0	Medium	5	1.2	87
A/G	686	0	High	5	2.0	145

Figure 4.3.3.3-1

Figure 4.3.3.3-1 shows that the air-to-air requirements for maximum lateral sideforce are the most demanding because of the lower dynamic pressure of the requirements flight conditions, and because of the loss of controller effectiveness at high angles of attack (figures 4.3.3.3-2 and 4.3.3.3-3).

It is clear from the analysis that the side force agility goals can only be reached by using several aerodynamic devices in combination. It is also clear that yaw thrust vectoring is the most effective device.

B-2 type split flaps are a powerful means of producing yawing moment. There is a small loss of lift and rolling moment to consider for trim of these flaps. The resultant increase in drag is large.

The early a/g designs showed swept-forward trailing edges. This was changed to scalloped-trailing edges so that B-2 type split flaps could be used to trim yawing moment developed by the side-force-producing devices.

**Wings left turn**

Control effectors provide the force

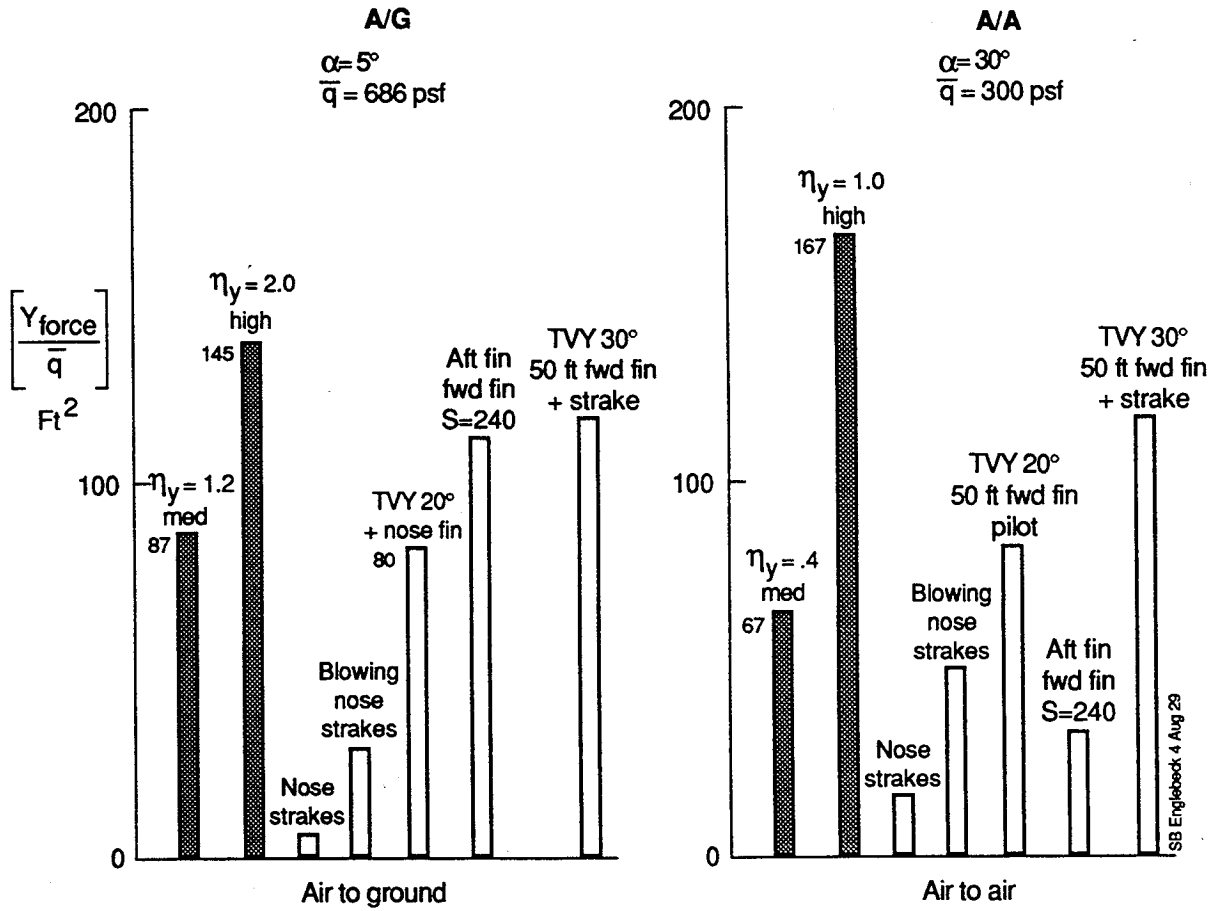
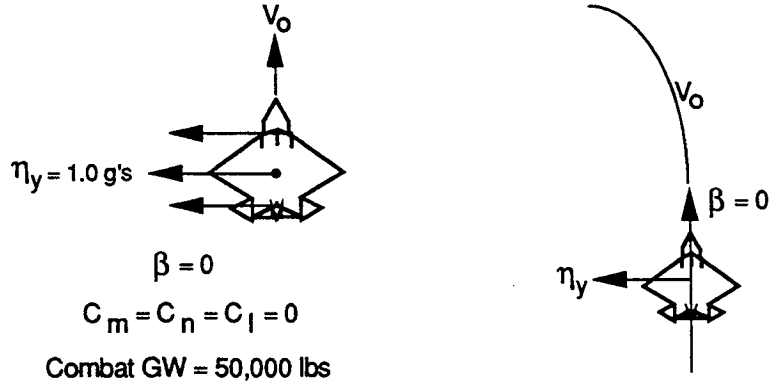
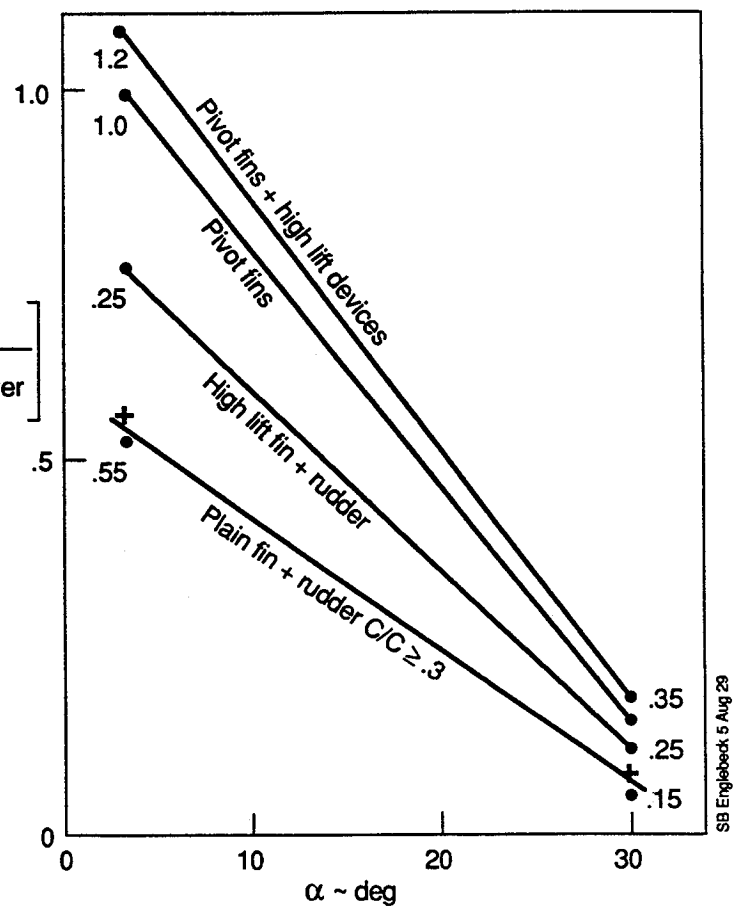

Figure 4.3.3.3-2. Side Force Control Effector Selection

$$\left[ \frac{C_{Y \text{ test limit}}}{\cos(\text{cant}) + K_{\text{carryover}}} \right]$$

Based on true area



SB English, 5 Aug 29

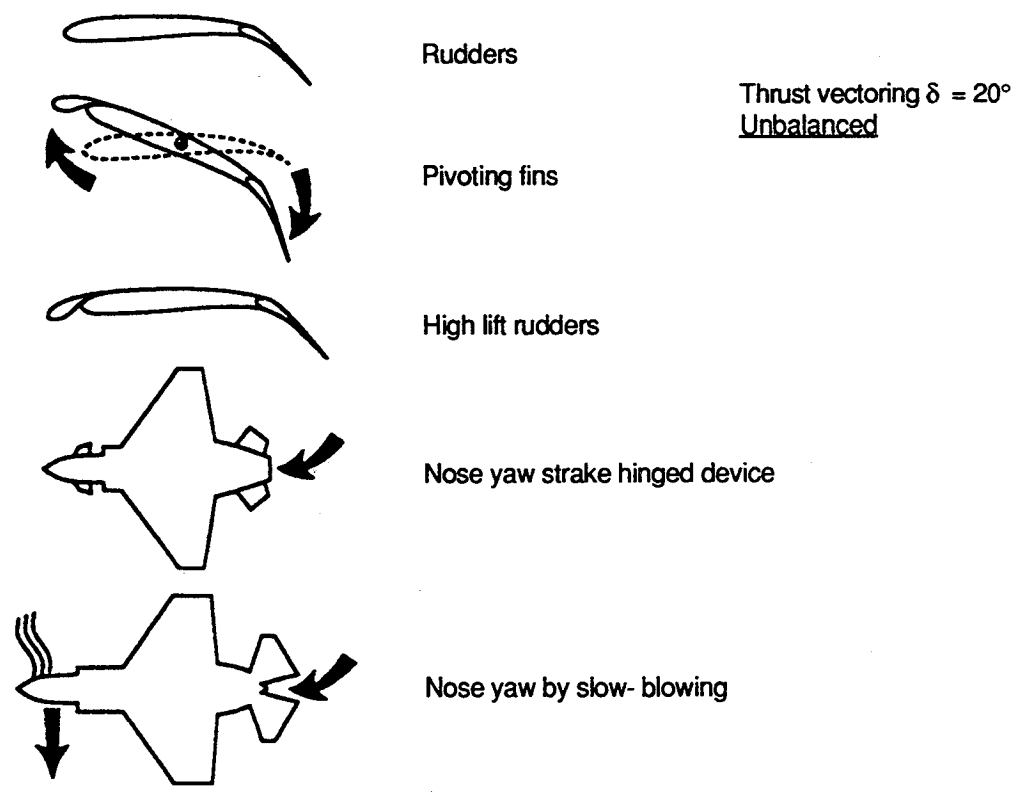

Figure 4.3.3.3-3. Sideforce Control Effector Effectiveness With Angle-of-Attack

#### 4.3.4 Configuration Evaluation

##### 4.3.4.1 Agility Impact on Low Observable Configurations

A vortex lattice model of the air-to-ground flying wing concept is shown in figure 4.3.4.1-1. The aerodynamic characteristics shown in figure 4.3.4.1-2 are the results from the vortex lattice method. The flight condition shown is a combat gross weight of 58,270 lb and an airspeed of 450 KEAS.

Both the high agility and low agility versions of this aircraft have the control power necessary to trim at the 9g limit load factor. This limit load occurs at an angle-of-attack of 10 degrees because of the low wing loading of the flying wing concept. The trim at this 9g condition requires less than a 10-degree trailing edge up deflection from the inboard flaps. An alpha limiter will be required to prevent inadvertent excursions outside the aircraft structural envelope. Limited pitch thrust vectoring in combination with trailing edge flaps yield a responsive capability in load factor while retaining powerful control power for alpha limiting.

The time to bank and capture 90 degrees was accomplished using the method outlined in section 4.3.3.1. The results are summarized in figure 4.3.4.1-3.

The time to bank and capture 90-degree agility requirements are well within this configurations ability to achieve. The yaw control power to balance the roll uses only 10% of the total available yaw control power.

A combination of four control effectors were used to meet the maximum lateral side force agility requirements. The control effectors and their contribution to the lateral side force are shown in figure 4.3.4.1-2.

The engine thrust is the dominate control effector, contributing 57% of the control power for the medium-agility aircraft and 77% of the control power for the high-agility aircraft. The aircraft T/W required to meet the high-agility level is 1.6, well outside what could be reasonably expected to be available on a fighter.

A smart digital flight-control system is required for the effective integration of the control effectors shown in figure 4.3.4.1-4. The roll coupling from the B-2 type split flaps were found to be small. Yaw control during the side force maneuver can be achieved by differentially varying split flap deflections or yaw thrust vectoring.

Yaw thrust vectoring is the most effective side force producing control effector. Oversizing the engine would translate into gains into maneuver performance at the expense of aircraft weight and range. Aerodynamic control effectors to achieve the side force requirements would increase the weight of the aircraft without any additional synergistic improvements anywhere except for the maximum lateral side force.

##### 4.3.4.2 Observables Impact of High Agility Designs

The vortex lattice model presented in figure 4.3.4.2-1 is a high agility moderate observable air-to-air fighter concept. The aerodynamics resulting from the vortex lattice analysis is presented in figure 4.3.4.2-2. Figure 4.3.4.2-3 presents the agility levels achieved by the concept aircraft broken down by control effector.

The pitch control power to trim the aircraft at high angles of attack is much greater than that required to meet the nose down pitch acceleration agility requirements. Pitch thrust vectoring is again the most effective control effector. The ability to trim the aircraft at 70 degrees angle-of-attack will require the combined use of pitch vectoring and over-rotating the horizontal tail.

- 1,196 panels
- 27 trapezoids

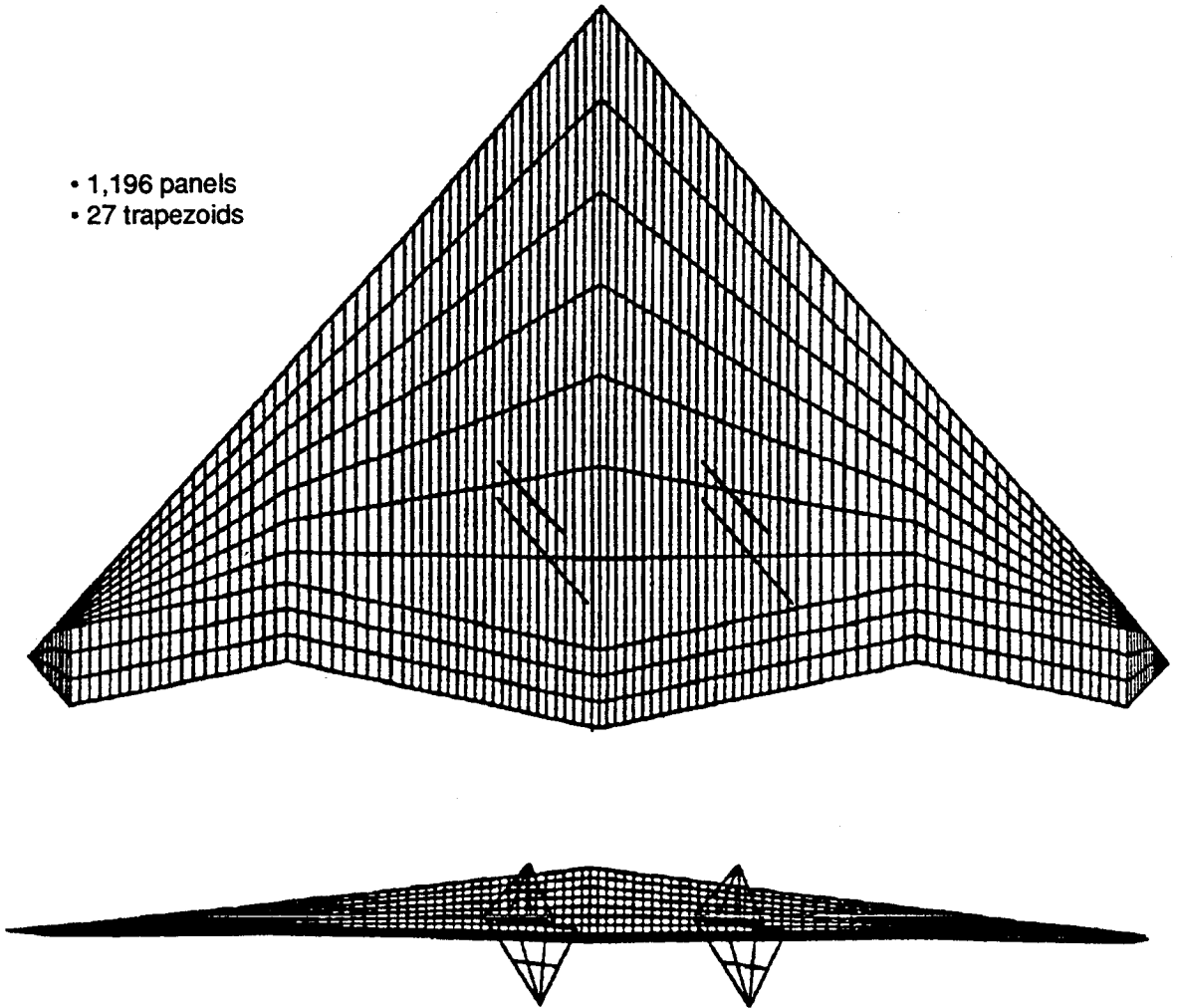

*Delta Wing Vortex Lattice Model*

Figure 4.3.4.1-1



Moment reference

$X_{ref} = FS 247.2''$

$S_{ref} = 1,496 \text{ ft}^2$

$B_{ref} = 68.33 \text{ ft}$

$C_{ref} = 335.18''$

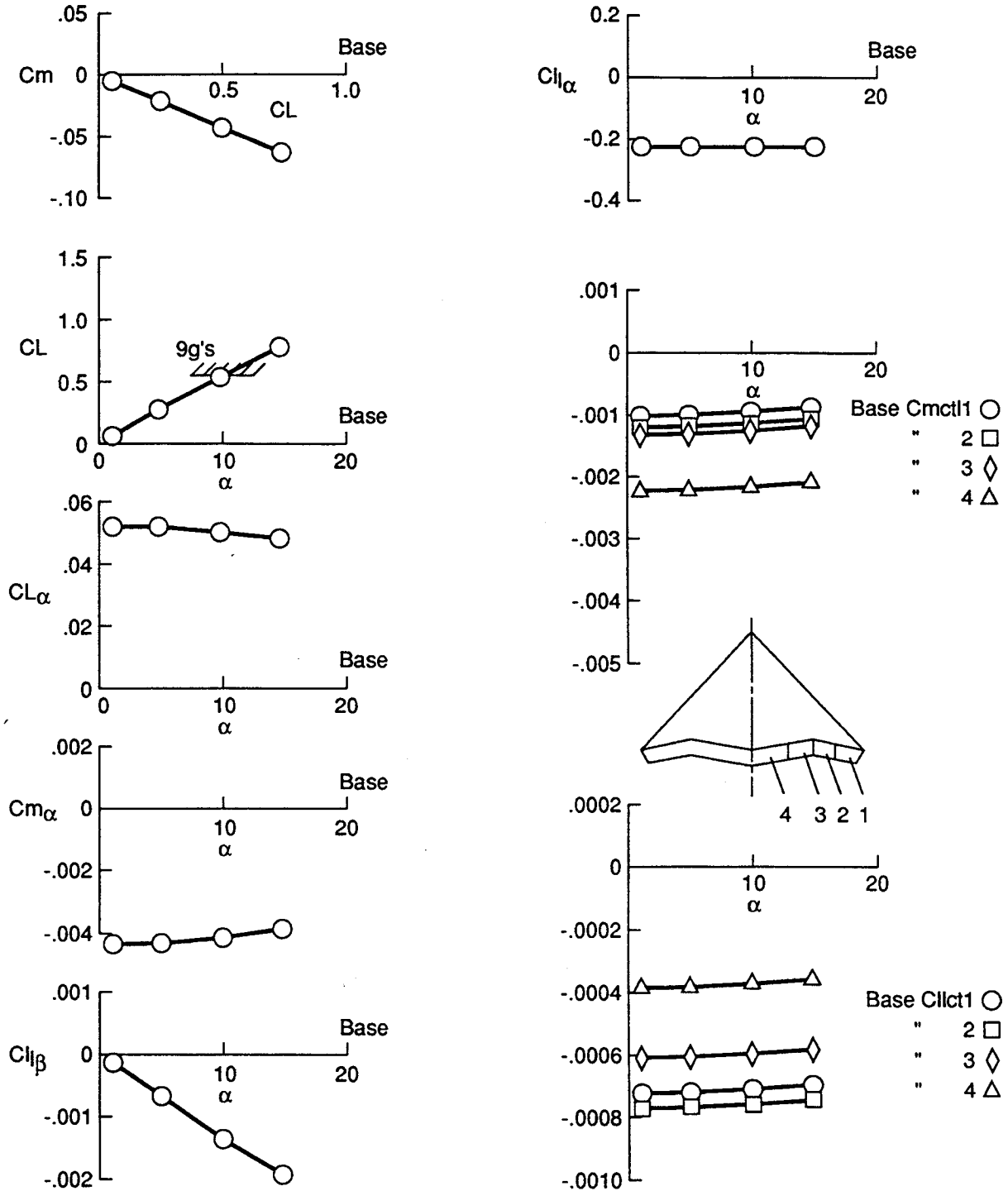

Figure 4.3.4.1-2

spb-8-7-re-Ad4

			Medium agility	High agility
Time-to-bank and capture 90°	– sec	t	1.5	1.0
Roll damping (stability axis)	– 1/rad	Lp	3.8	3.8
Roll acceleration	– rad/sec	$\ddot{\theta}$	5.5	9.8
Rolling moment coefficient required		$\Delta C_{lreq}$	.0146	.0256
Control surface deflection	– deg	$\delta$	10	30

*Figure 4.3.4.1-3. Time-to-Bank and Capture 90 Degree*

# AG 2501 Side Force Agility

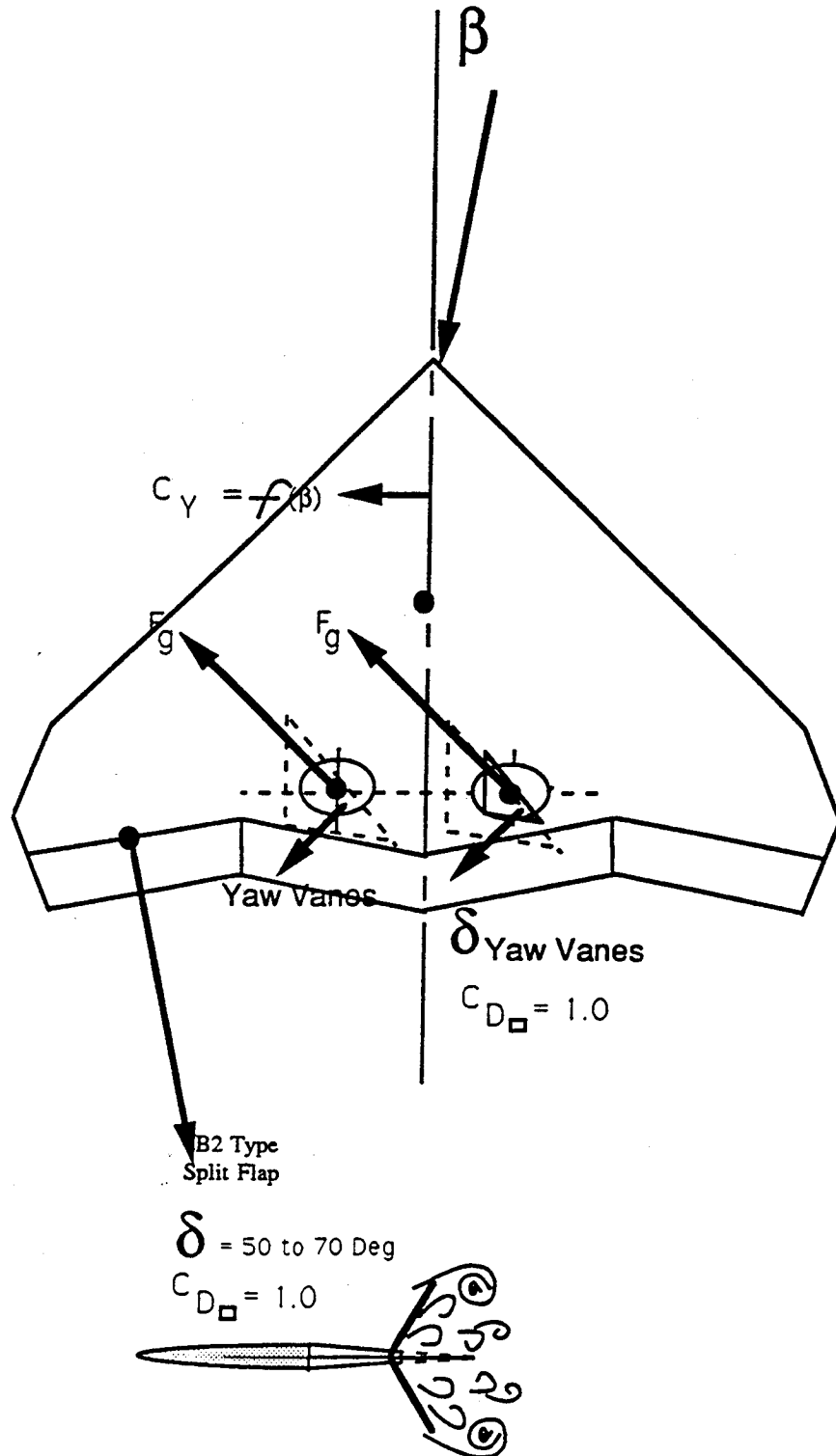

Delta Side Force Control Concept

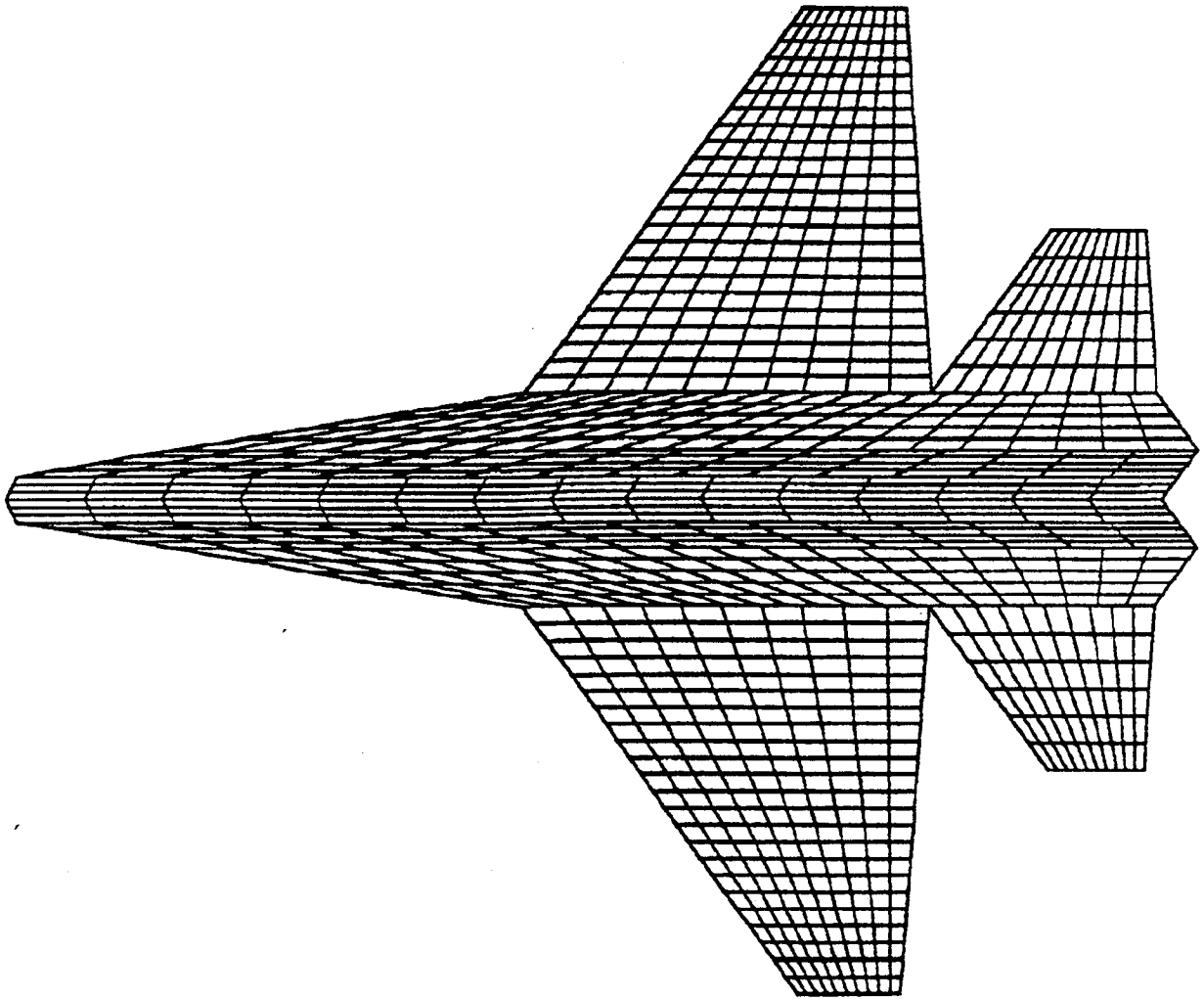

**988-115 Vortex Lattice Model**

Figure 4.3.4.2-1

Moment reference

$X_{ref} = FS 392"$

$S_{ref} = 1,062 \text{ ft}^2$

$B_{ref} = 48.8 \text{ ft}$

$C_{ref} = 192"$

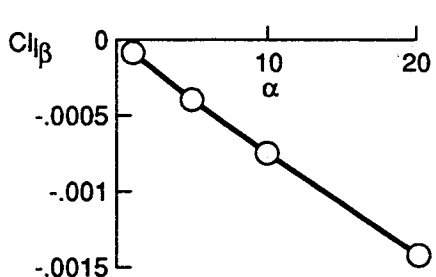
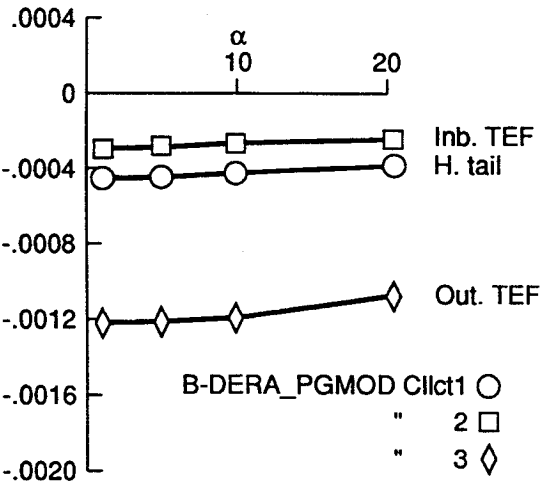
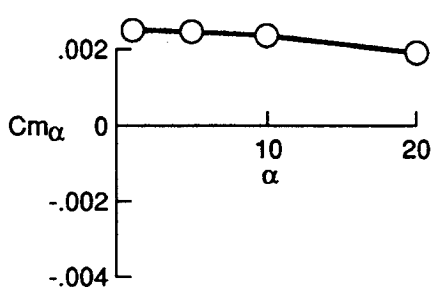
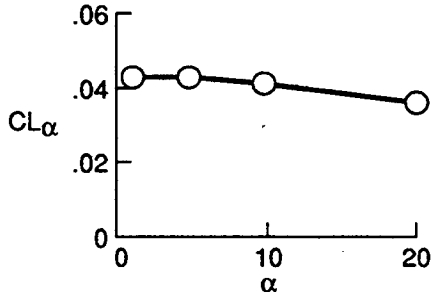
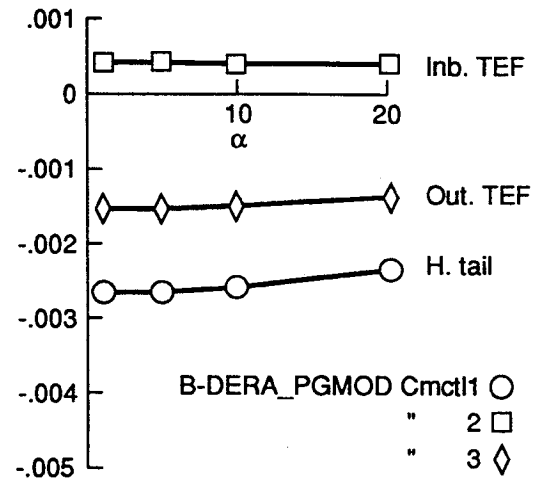
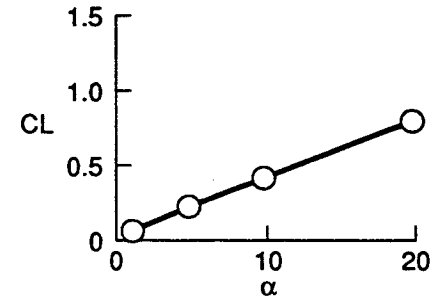
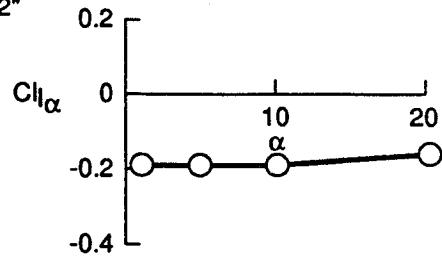
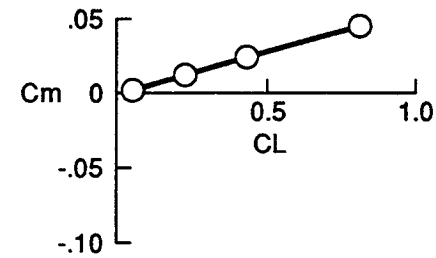

988-115 Aerodynamic Characteristics

Figure 4.3.4.2-2

sps-8-7-re-Ad5

$\bar{x}$  aft limit = .33 $\bar{c}$

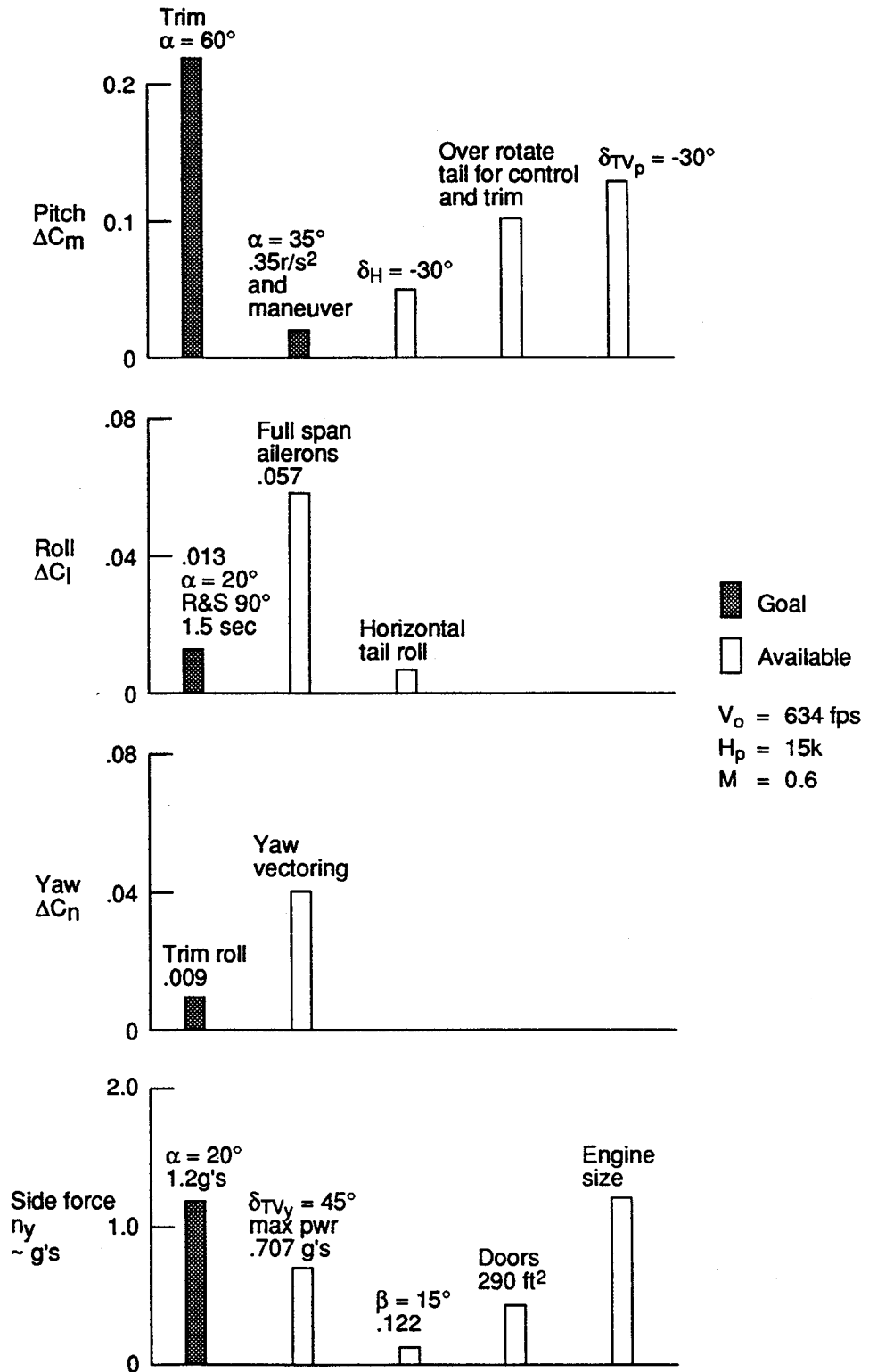

988-115 Control Effector Selection

Figure 4.3.4.2-3

Roll control power is sufficient to meet the time-to-bank and capture 90 degrees agility requirement. Sufficient yaw control power is available to balance the yawing moment generated by the roll about the velocity vector.

Side force is dependent on yaw thrust vectoring as were the low observable designs presented in the previous section.

One of the key design traits of low observable designs is the emphasis on keeping the number of control surfaces down to a minimum. The most obvious impact is the lack of control surfaces available to address any handling quality or agility requirement. Side sector signature is completely counter to the availability of efficient lateral control devices to meet the maximum lateral side force agility requirements. Any significant side sector signature requirement drives the aircraft to a highly coupled V-tail configuration and eventually to eliminating the tails altogether. Analysis has shown that yaw thrust vectoring is the most effective control effector in achieving the maximum lateral side force agility requirements.

The signature impact on longitudinal agility requirements are not as extreme as that of the lateral-directional agility just discussed. This observation is primarily due to the horizontal orientation of the most effective pitch control effectors is favorable to signature requirements. Even with the availability of numerous options for pitch control effectors, pitch thrust vectoring is the most effective control effector.

Time to bank and capture 90 degrees does not seem to be affected by the signature issue. This is because the most effective roll control devices have the favorable horizontal orientation and wing ailerons seem to have the control power necessary to meet the agility requirements

## 5.0 Configuration Synthesis Results

There are primarily two approaches to aircraft synthesis studies, numerical optimization and the traditional trade study approach. The numerical optimization approach provides a highly refined optimized solution subject to all the constraints supplied and limitations of the parametric sizing models. The traditional trade study approach is a long cumbersome series of trade studies that eventually reveal an optimal solution. The traditional trade study approach was selected because it provides the visibility into what the important design parameters are, where the design constraint boundaries are relative to each other, and what the sensitivities are about the design point. The "blackbox" nature of numerical optimization does not lend itself to visualizing these global issues.

### USAF Customer

Six of the twelve study configurations were designed for an USAF only customer. Traditionally the most important design parameters determining the size and cost of a concept is engine size (T/W), wing size (W/S), and wing shape (AR). Generally the aircraft thrust-to-weight (T/W) ratio was driven by the maneuver requirements, wing loading (W/S) was driven by the instantaneous turn requirements, and aspect ratio (AR) was varied to minimize the empty weight/cost of the designs.

Agility requirements of maximum achievable angle-of-attack, minimum nose down pitch acceleration, and time-to-bank and capture 90° are primarily determined by the control power and inertial characteristics of the basic concept. Traditionally these issues are ignored in the configuration screening stages until wind tunnel data becomes available to address these and many other handling qualities issues. In this study, control effector sizing for agility was built into the overall concept using the process discussed in Section 4.3. Control effector volume coefficients were held constant during the synthesis studies with the assumption that scaling control effectors size using constant volume coefficients would yield similar handling characteristics. There is no data to support this assumption. The agility requirements for maximum negative specific excess power only drove the air-to-ground configurations until the maneuvering flap was added to the concepts. The maneuver requirements for the A/A and A/G configurations were demanding on aircraft T/W requirements.

The most demanding agility requirements for these tailless configurations is the maximum lateral sideforce requirements. Yaw vectoring is the single most effective means of achieving the sideforce agility requirements for the high T/W A/A configurations. The T/W level required to meet the maximum negative specific excess power agility, on the A/G configurations with the leading edge device, was too low to have sufficient yaw control power from yaw vectoring alone. Deployable yaw vanes and split ailerons were added to increase the yaw control power to meet the maximum lateral sideforce agility requirement.

### Joint Service Customer

The remaining six of the twelve configurations are derivatives of their Air Force counterparts. Generally, a 15 to 17% increase in empty weight over their Air Force counterparts to do the same mission and meet the same maneuver requirements. This increase in empty weight is due to increased structure to accommodate higher design sink speeds for landing gear design, tail hook, nose wheel shuttle, and wing folding mechanism.

## 5.1 The Global Design Space

The Air-to-Ground Maneuver requirements were examined in a Global Design Space Study presented in figure 5.1. This figure shows the variation of aircraft thrust-to-weight required to meet the air-to-ground maneuver and agility requirements with the aircraft geometry varying in a historically relevant trend. The 6.5g maneuver requirement was the dominate requirement sizing the engine except for the Maximum Negative Specific Excess Power Agility requirement. The interpretation of the Maximum Negative Specific Excess Power Agility requirement at the time this data was generated was that the flight condition occurred at  $C_{L,max}$ . The conclusion drawn from this chart was that configuration with poor high lift capabilities had an advantage over more maneuver able designs because they could not



reach the same high lift conditions. Therefore the Maximum Negative Specific Excess Power Agility requirement was modified to occur at a constant load factor to negate influence of obtainable  $C_{Lmax}$ .

Similar historically relevant trend data were used to examine the global design space of the air-to-air maneuver requirements. The results presented in figure 5.2 show that the medium agility level of Maximum Negative Specific Excess Power requirement does not drive the size of the engine required. The high agility levels match the maneuver requirements. Concern about the transonic acceleration requirements are only relevant at the low wing loading, high aspect ratio portions of the design space. Expected aircraft thrust-to-weight ratios in configuration sizing trade will be from 1.1 to 1.3.

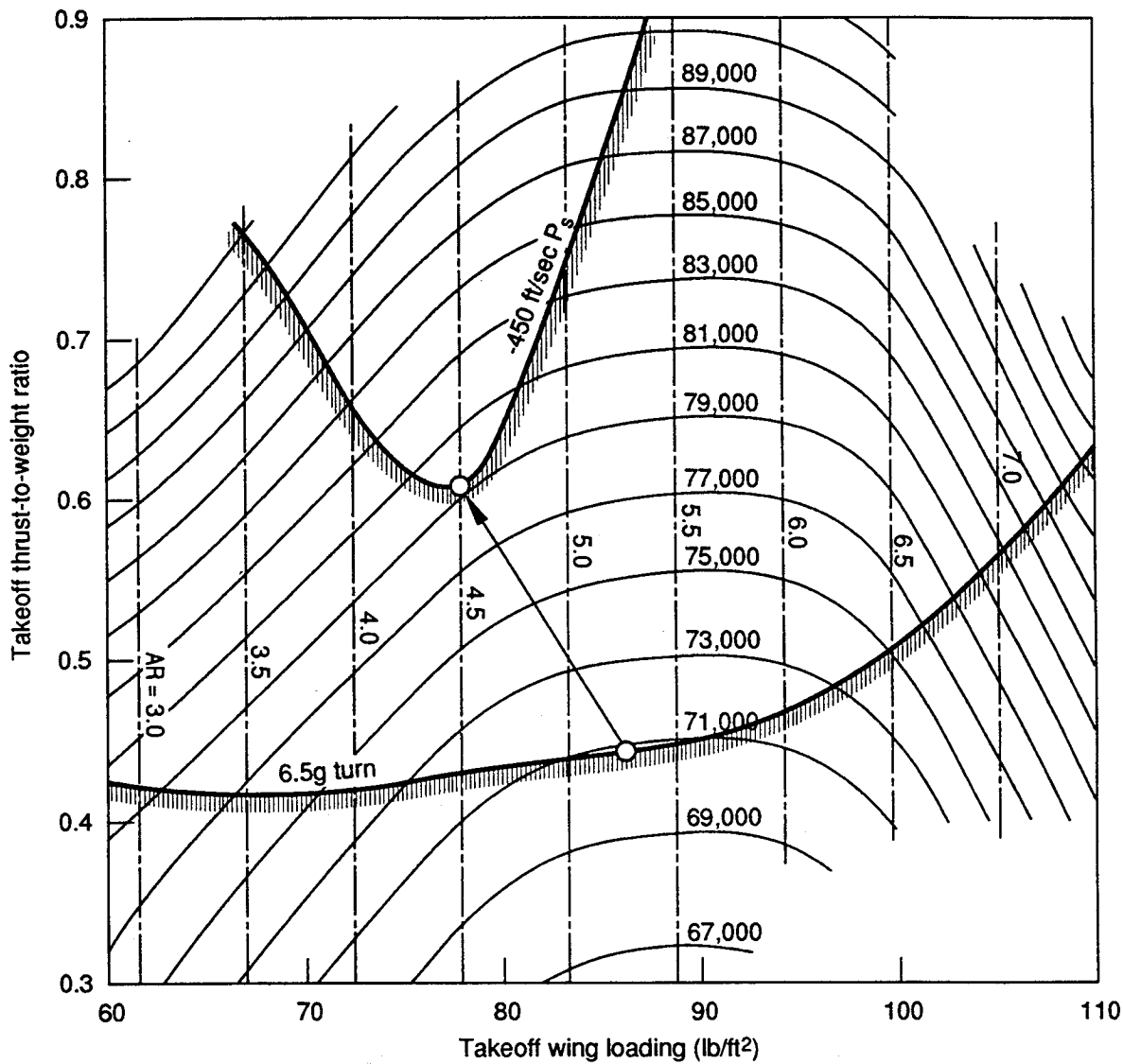
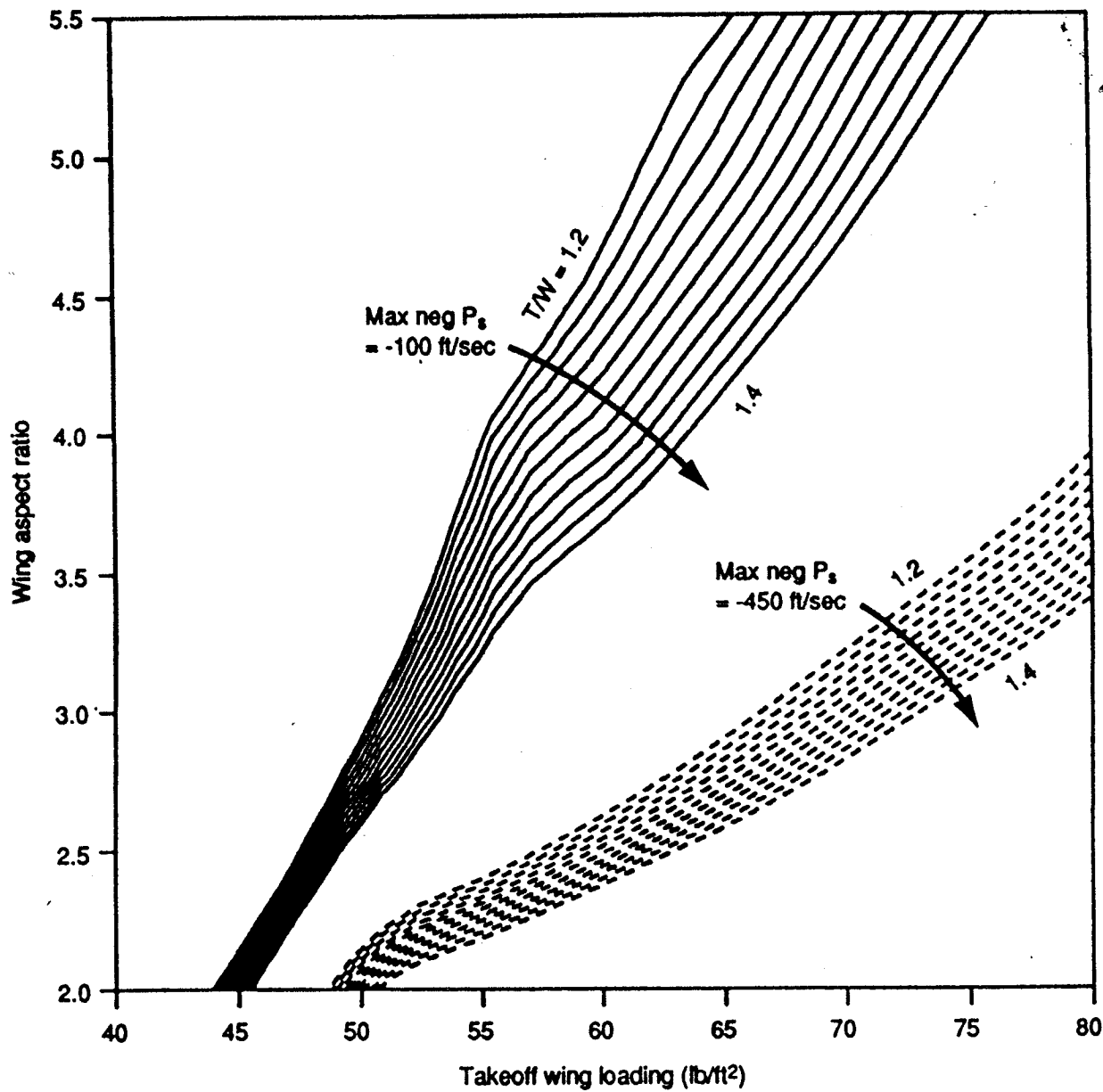

Figure 5.1. Global Design Space; Twin Engine Air-to-Ground Deltoid; Takeoff Gross Weight (lb)



Generic A/A Configuration; A/A Max Neg P<sub>s</sub> Requirement; T/W Required

ORIGINAL PAGE IS  
OF POOR QUALITY

spb-7-7-re-C2

85 A.

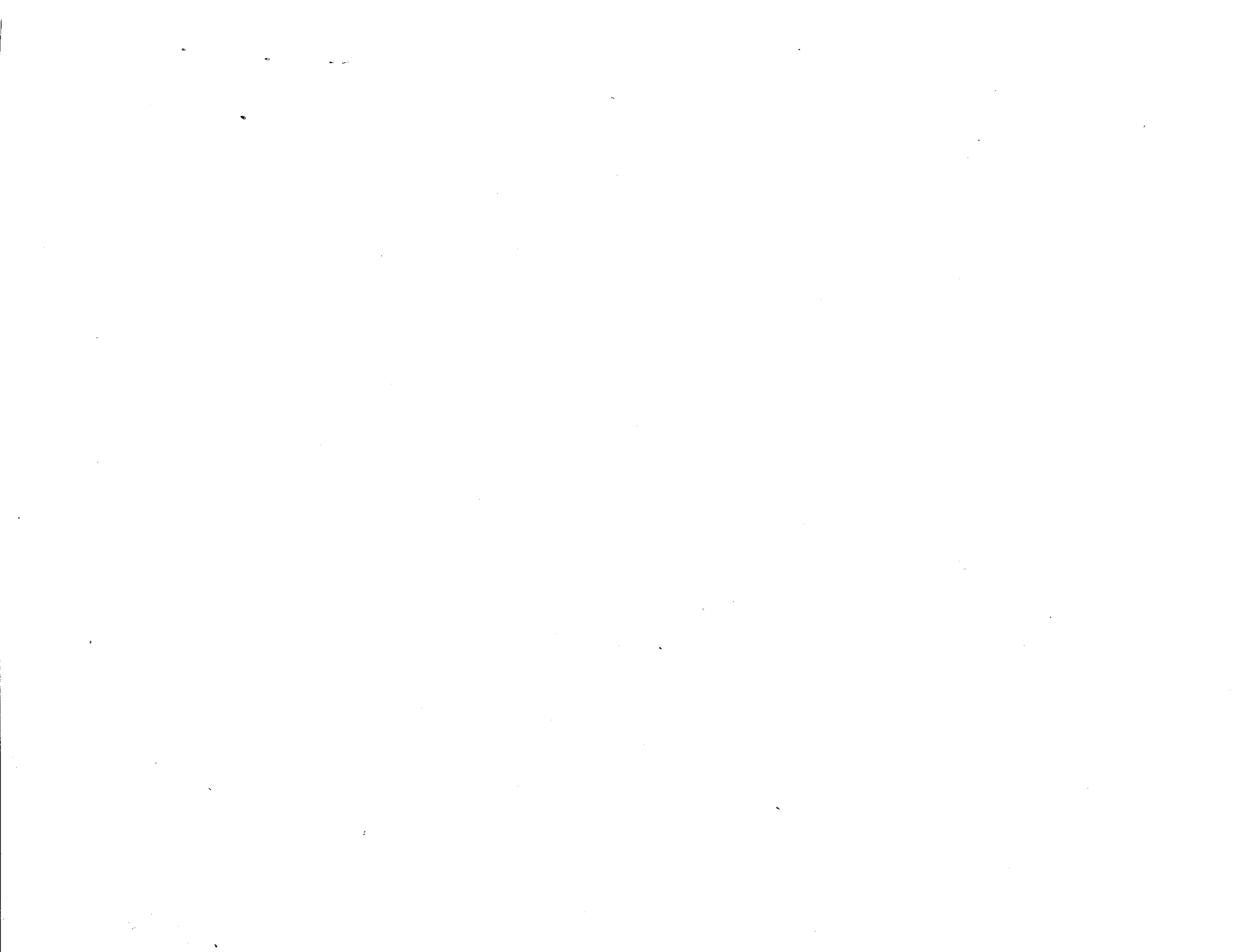

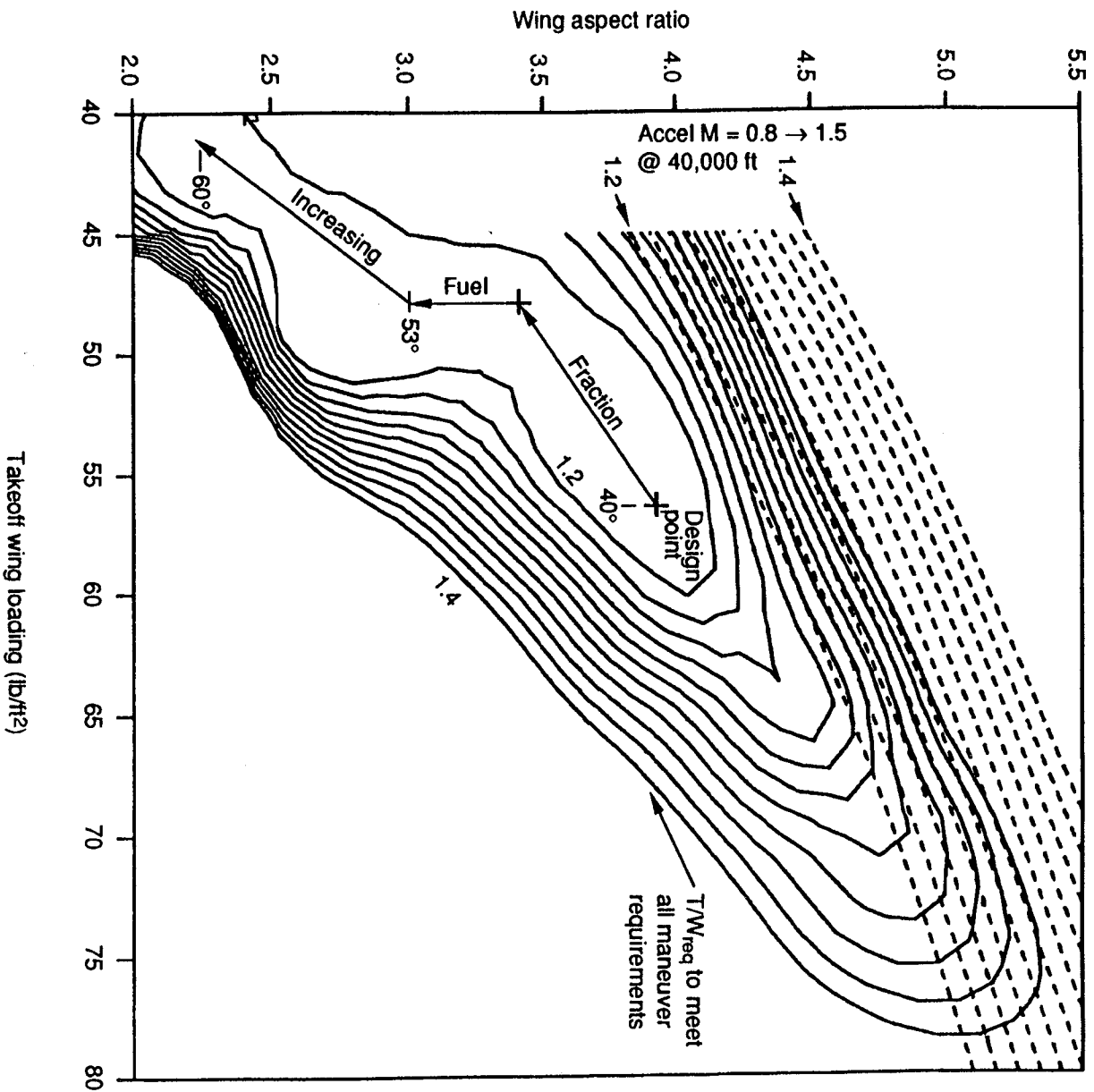

Figure 5.2. Generic A/A Configuration; NASA Maneuver Requirements; T/W Required

## 5.2 Aircraft Synthesis Results

The aircraft synthesis approach consists of four steps, as illustrated on figure 5.3, and discussed below.

### Step 1 "Preliminary Layout and Sizing"

This consists of preliminary layout and sizing of an aircraft that will be used as a starting point for the parametric analysis. This is typically a one or two day effort to (1) identify specific technologies, (2) size fixed equipment and develop general arrangement of crew accommodations, instruments, avionics, gun and provisions, ammunitions weapon bay...etc., (3) develop overall shape to best meet system requirements and (4) estimate fuel requirements and size and layout of the aircraft.

### Step 2 "Parametric Analysis"

This effort requires the rapid analysis of a large number of aircraft designs that meet all system requirements; it is computation intensive and has been mechanized. The "Fighter Aircraft Sizing Tool" (FAST) of reference (1) is employed. Specific tasks are:

- (1) Determine aerodynamics characteristics, fuel requirements and maneuver capability of a specific configuration on a specific mission.
- (2) Package fixed equipment and fuel perform loads, stress and mass property analyses and size aircraft (iterative process required with (1) above).
- (3) Conduct configuration trade studies to identify the minimum weight configuration that will perform the specified mission within the imposed system constraints. Typically, wing loading, thrust-to-weight ratio, and wing aspect ratio, leading edge sweep and thickness-to-chord ratio are varied. Considerable interaction between final layout and sizing (Step 3) exists during the selection of a configuration.

### Step 3 "Final Layout and Sizing"

Using the parametric sizing results as a guide, apply sound engineering sizing, packaging and mass properties analyses to develop a final aircraft design.

### Step 4 "Final Performance"

Determine the performance capability of the final configuration using the FAST program.

#### 5.2.1 Air-to-Ground Configurations

The preliminary layouts of both the high agility and medium agility designs consisted of a delta configuration with a saw-tooth trailing edge to satisfy the low observable requirement. The configuration consisted of (1) a 1500 ft<sup>2</sup> wing with aspect ratio of three, (2) no leading edge device and (3) a thrust level of 22,840 lb.

The parametric sizing results are provided on figure 5.4. The analysis consisted of an investigation of (1) wing leading edge sweep, (2) then wing aspect ratio, (3) then thrust-to-weight ratio and finally (4) the addition of a leading edge device to meet the maximum negative specific power requirement at significantly reduced gross weight.

The selected configuration was a compromise between (1) minimum weight, (2) the ability to balance a delta configuration, and (3) the ability to maintain a 6.5g sustained maneuver at sea level and mach = 0.8 lb. It has the following characteristics.

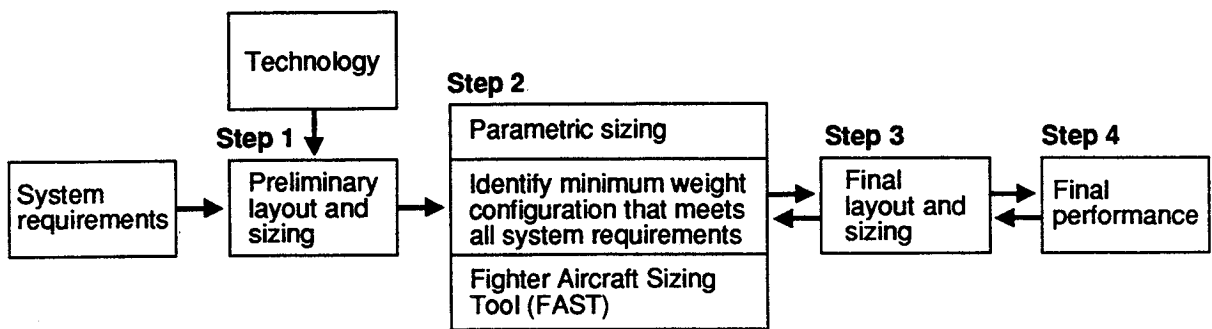

Figure 5.3. Aircraft Synthesis Approach

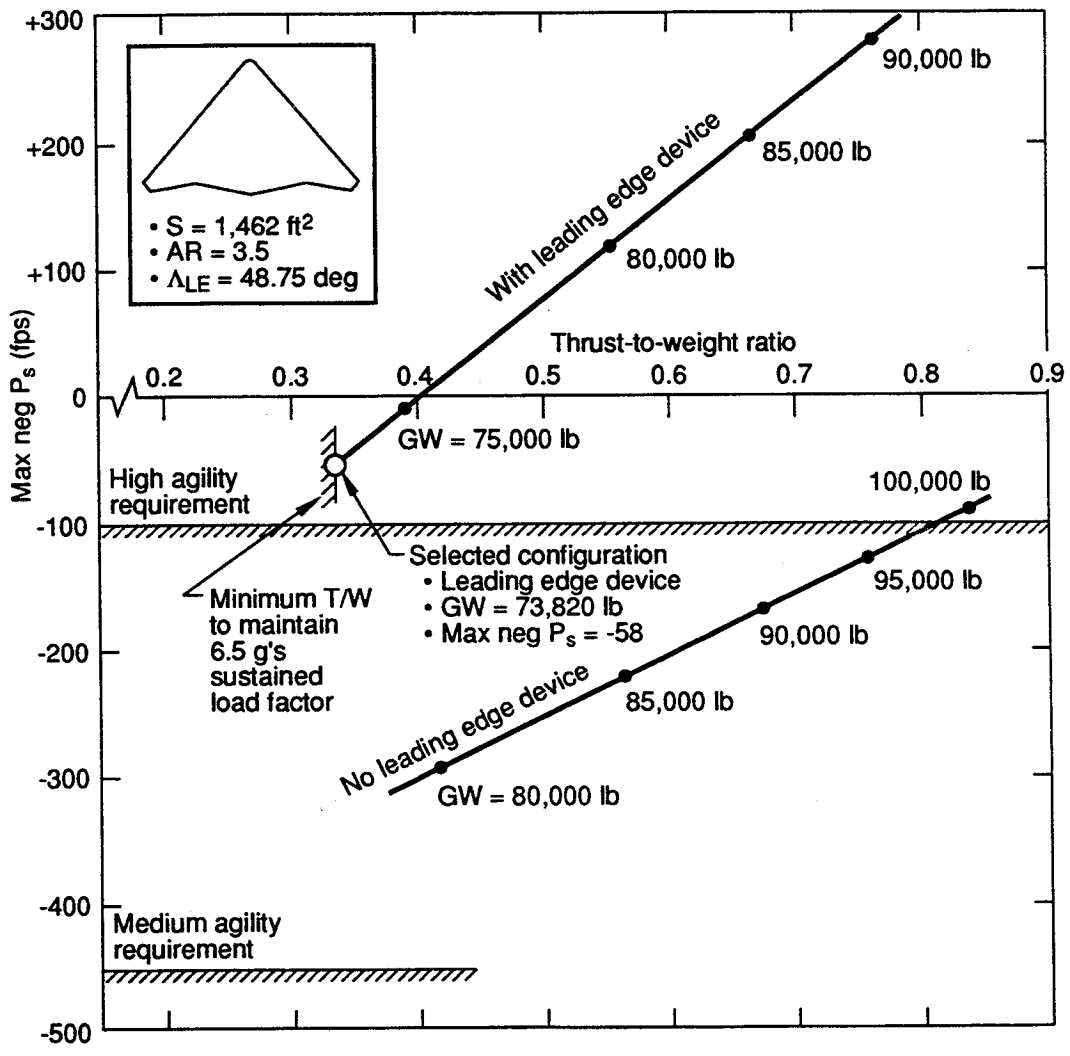
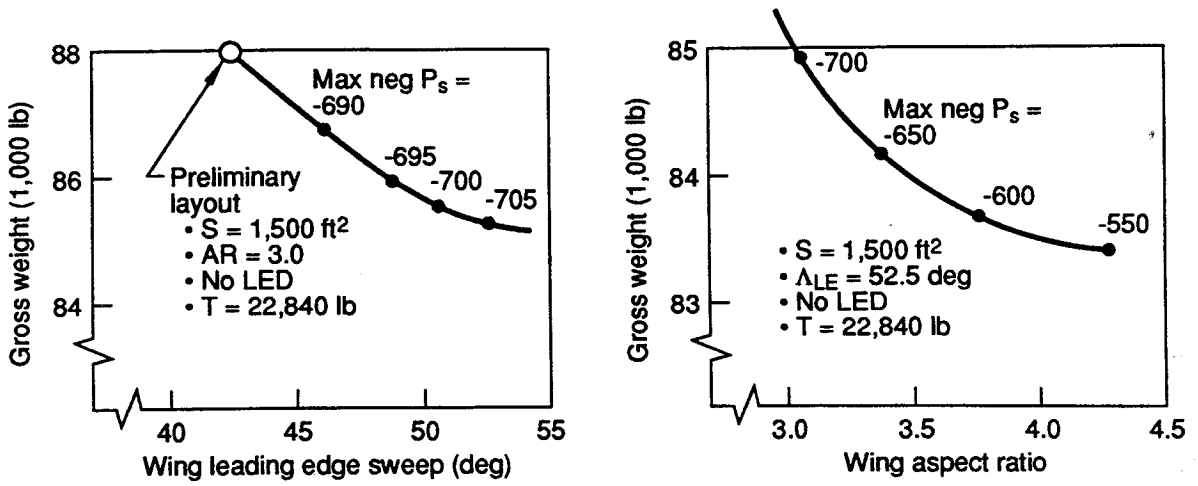

Figure 5.4. Air-to-Ground Configuration Sizing Charts



- . Wing area = 1462 ft<sup>2</sup>
- . Aspect ratio = 3.5
- . Wing leading sweep = 48.75 degs
- . Thrust-to-weight ratio 0.336
- . Gross weight = 73,820 lb

The same configuration was selected for both the high agility and medium agility design because it represents the minimum weight design. As shown on figure 5-4, it is possible to satisfy the 450 fps maximum negative specific power requirement of the medium agility design, but the weight is greater.

The important design parameters are tabulated in the order of significance in table 5.5. The leading edge device provides a significant weight reduction due to its aerodynamic effect, as shown on figure 5.7. It provides a significant improvement in lift coefficient at low angles of attack and a slightly improved maximum lift-to-drag ratio.

The design sensitivities about the design point are provided on table 5.6. Another interesting sensitivity, although it is not about the design point, is provided on figure 5.8. Presently, the requirement is to calculate the maximum negative specific power at the point in the mission where 60% of the fuel remains on board. If this requirement were changed to 50% fuel remaining on board, the aircraft gross weight could be reduced 6,700 lbs.

#### 5.2.2 Air-to-Air Configurations

##### High Agility

The variation of aircraft gross weight with the significant design parameters and design constraint boundaries is illustrated on the configuration sizing chart on figure 5.9. The chart was constructed with a thrust-to-weight ratio of 1.125 which allows a small design space between the sustained load constraint of 4.4 g's (H = 20,000 ft at M = 0.6) and the specific power constraint of 550 fps (M = 30,000 ft at M = 0.9). The other twenty-four constraints are all satisfied. Note that the minimum weight design occurs at an aspect ratio of approximately 5.5. It is anticipated that this design would be subject to a severe weight penalty due to flutter. Without a detailed analysis, we have selected a design with a lower aspect ratio to avoid flutter. The selected configuration lies on the sustained load design constraint at an aspect ratio of 3.75. It has a gross weight of 59,835 lb. Other characteristics are tabulated on figure 5.9.

##### Medium Agility

The variation of aircraft gross weight with the significant design parameters and design constraint boundaries is illustrated on the configuration sizing chart on figure 5.10. The chart was constructed with a thrust-to-weight ratio of 1.13 which allows a small design space between the instantaneous load constraint of 9 g's (M = 30,000 ft at M = 0.9) and the specific power constraint of 550 fps (H = 30,000 ft at M = 0.9). Again, the minimum weight configuration occurs at a higher aspect ratio, but a configuration with an aspect ratio of 4.0 was selected to avoid flutter.

#### 5.2.3 Multi-Role Configurations

##### High Agility

The variation of aircraft gross weight with the significant design parameters and design constraint boundaries is illustrated on the configuration sizing chart on figure 5.11. The chart was constructed with a thrust-to-weight ratio of 1.1 which allows a small design space between the sustained load constraint of 4.4 g's (H = 20,000 ft at M = 0.6) and the specific power constraint of 550 fps (H = 30,000 ft at M = 0.9). The other twenty-four constraints are all satisfied. Although a slight weight saving is indicated at higher aspect ratios, a configuration with aspect ratio of 4.38 and wing loading of 67.5 psf was selected to avoid flutter.

**Table 5.5. Important Design Parameters**

Parameter	Significance
1. Wing leading edge device	Results in a 25,000 lb weight reduction at maximum negative specific power of -100 fps
2. Thrust-to-weight ratio 3. Wing aspect ratio	Maximum negative specific power and gross weight are extremely sensitive to these parameters

**Table 5.6. Design Sensitivities About the Design Point**

Partial of:

	Gross weight (lb)	Maximum negative specific power (fps)
Thrust-to-weight	+35,600	+765
Leading edge sweep (deg)	-240	+2.3
Aspect ratio	-1,430	+125

With respect to:

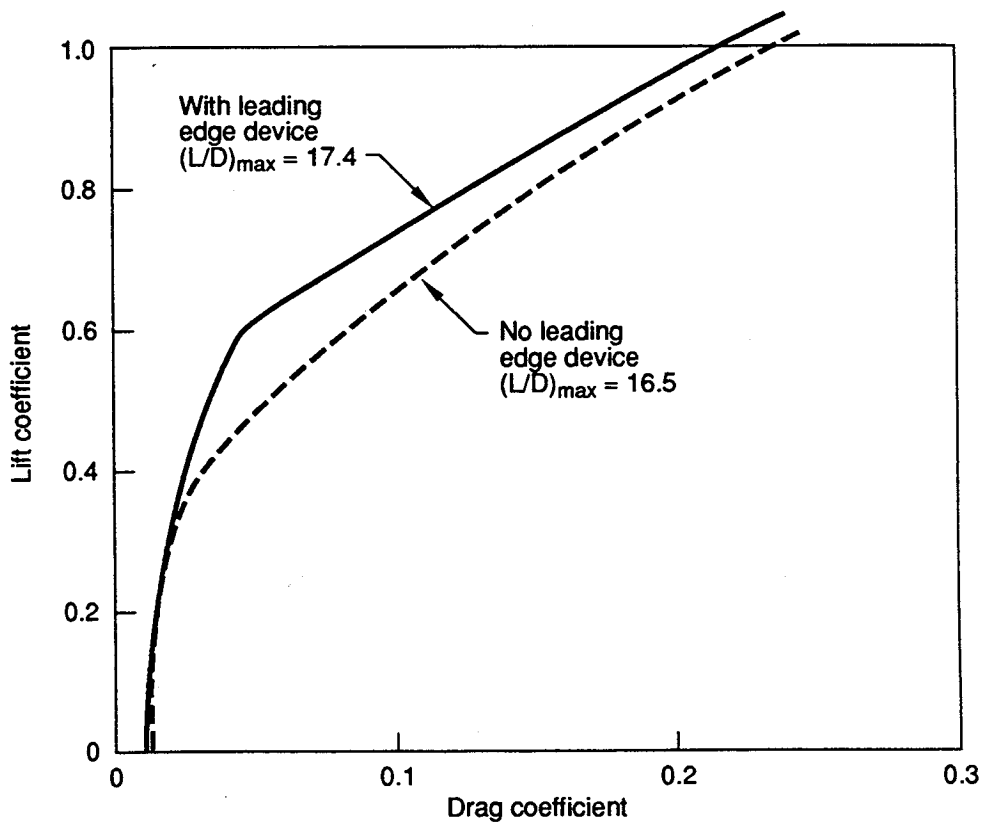
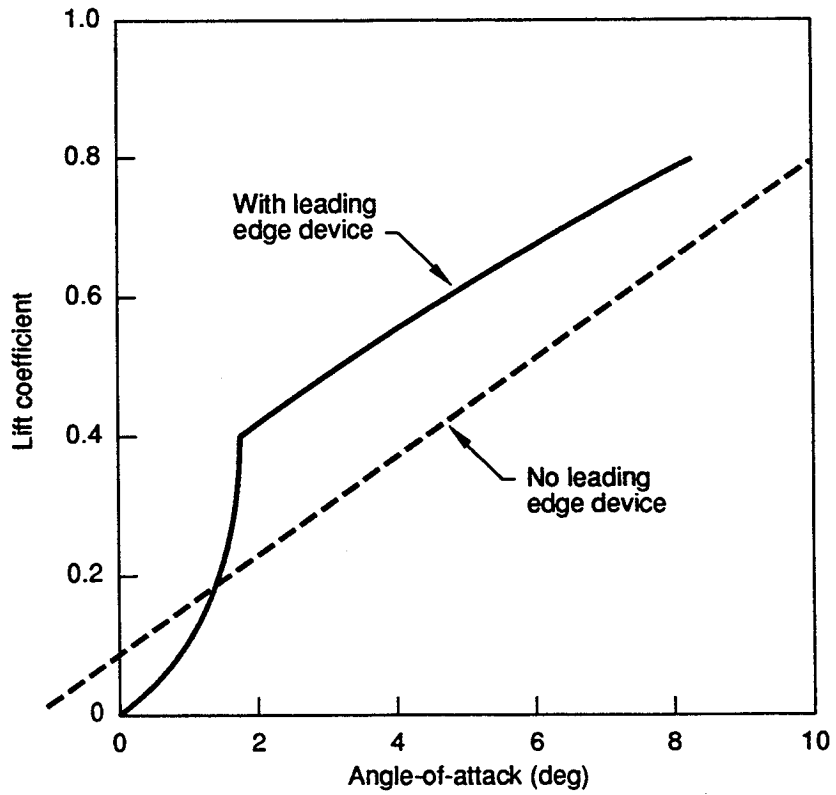

Figure 5.7. Aerodynamic Effect of Leading Edge Device

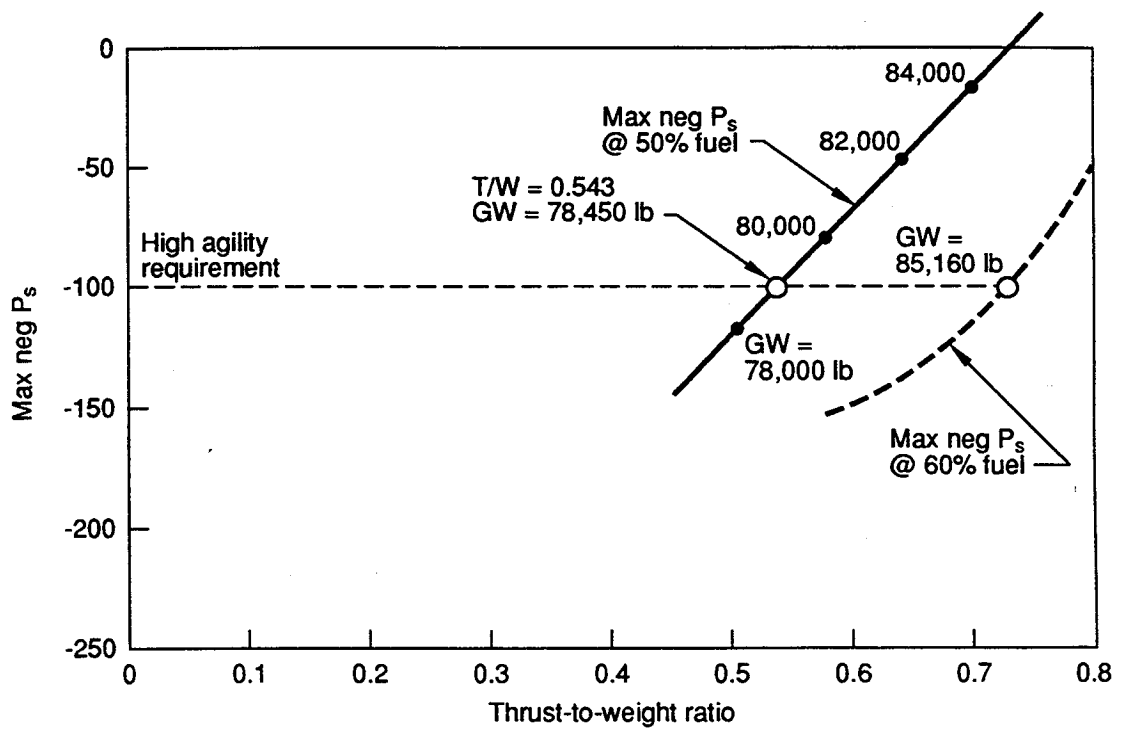

Figure 5.8. Design Sensitivity to Fuel Load for Max Neg  $P_s$  Requirement

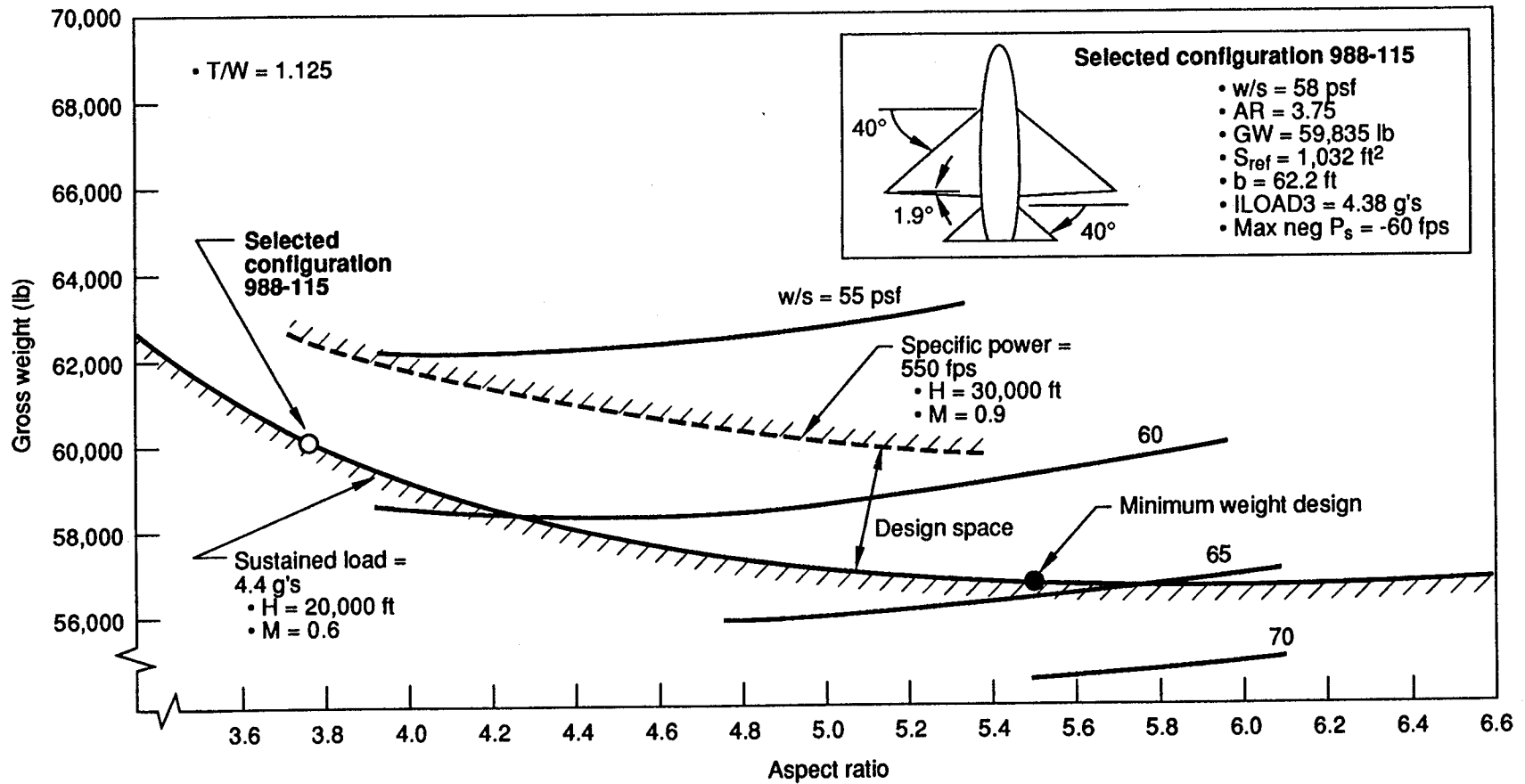

Figure 5.9. Air-to-Air, High Agility Configuration Sizing Chart

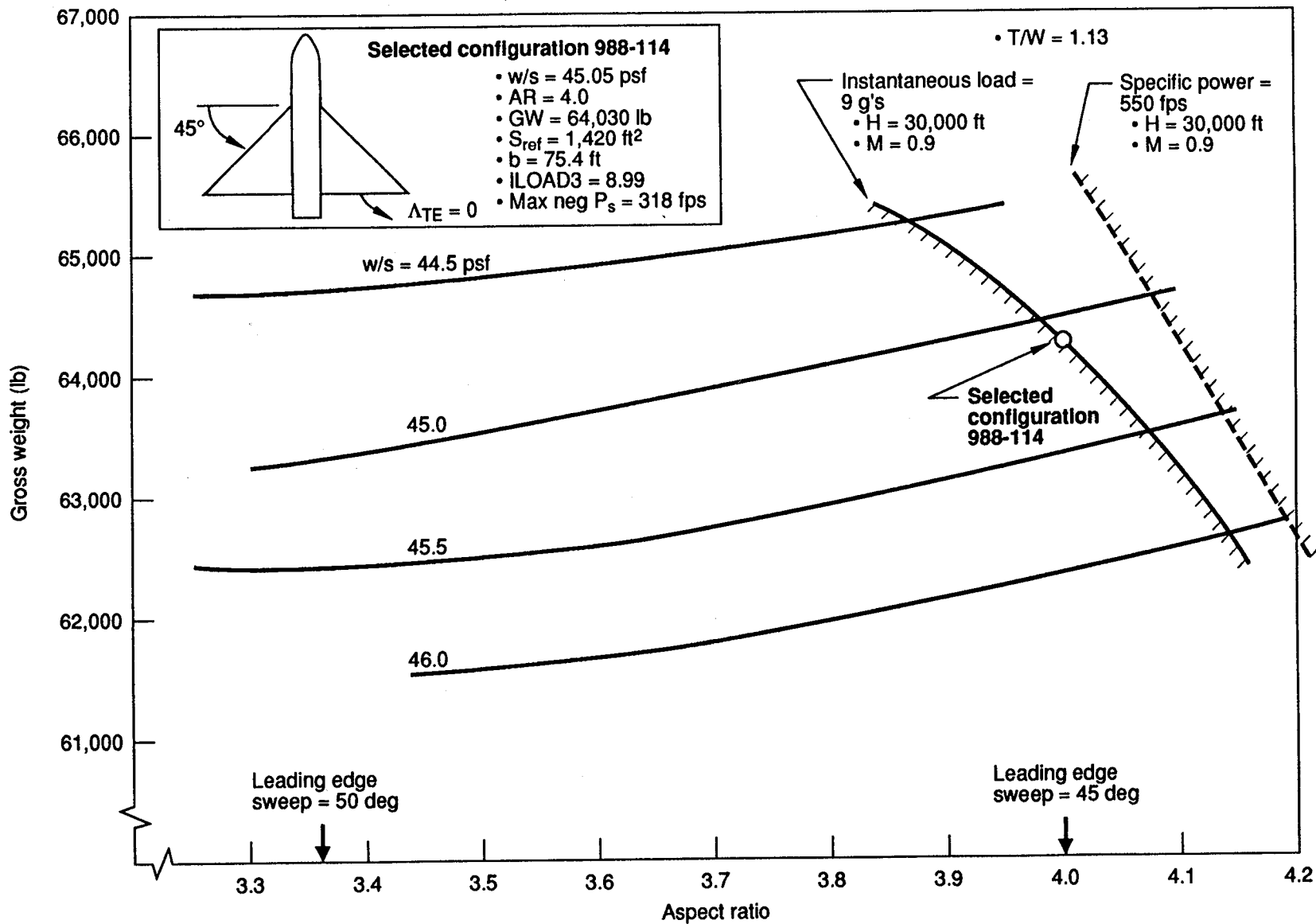

Figure 5.10. Air-to-Air, Medium Agility Configuration Sizing Chart

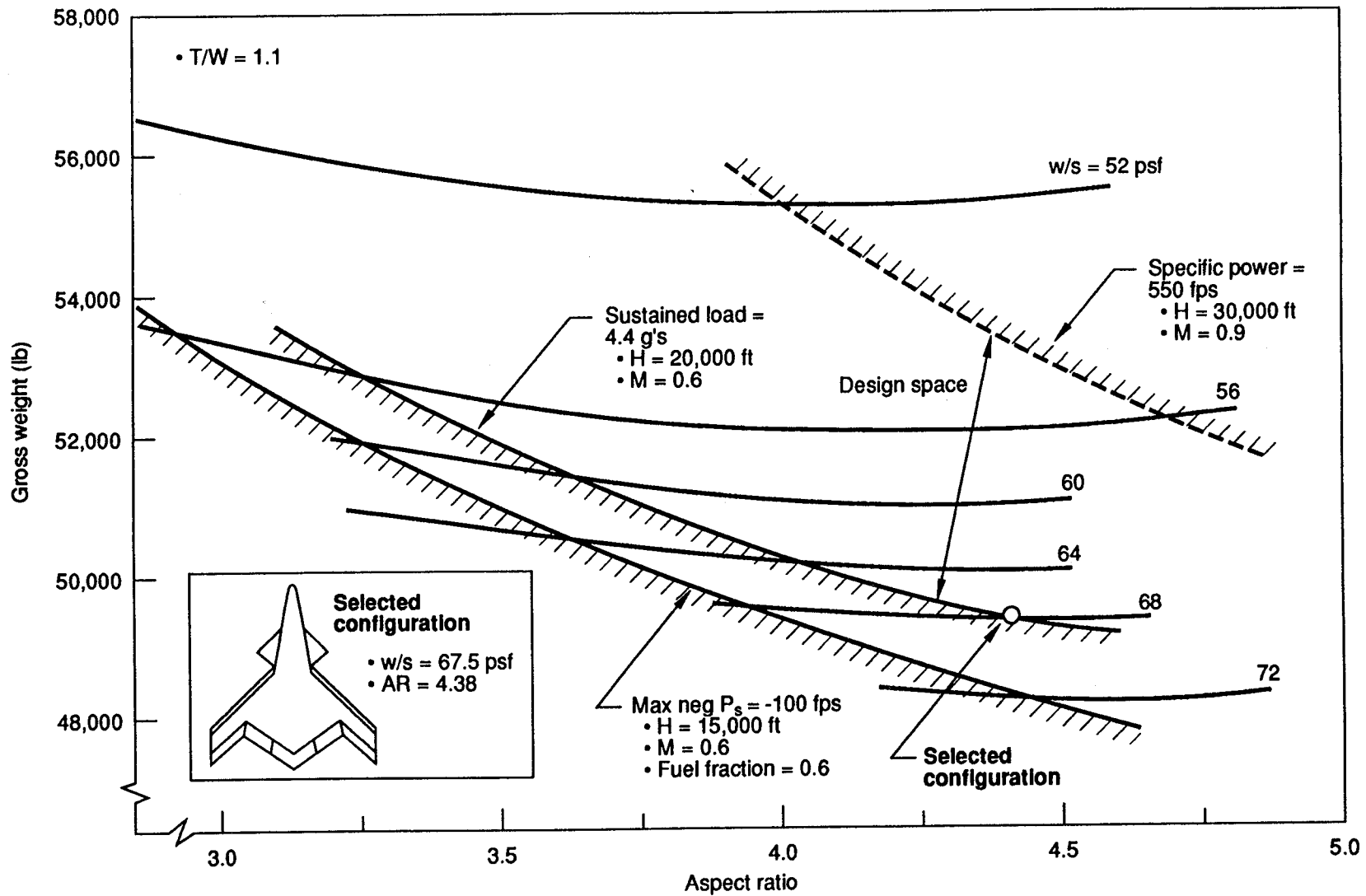

Figure 5.11. Multi-Role, High Agility Configuration Sizing Chart

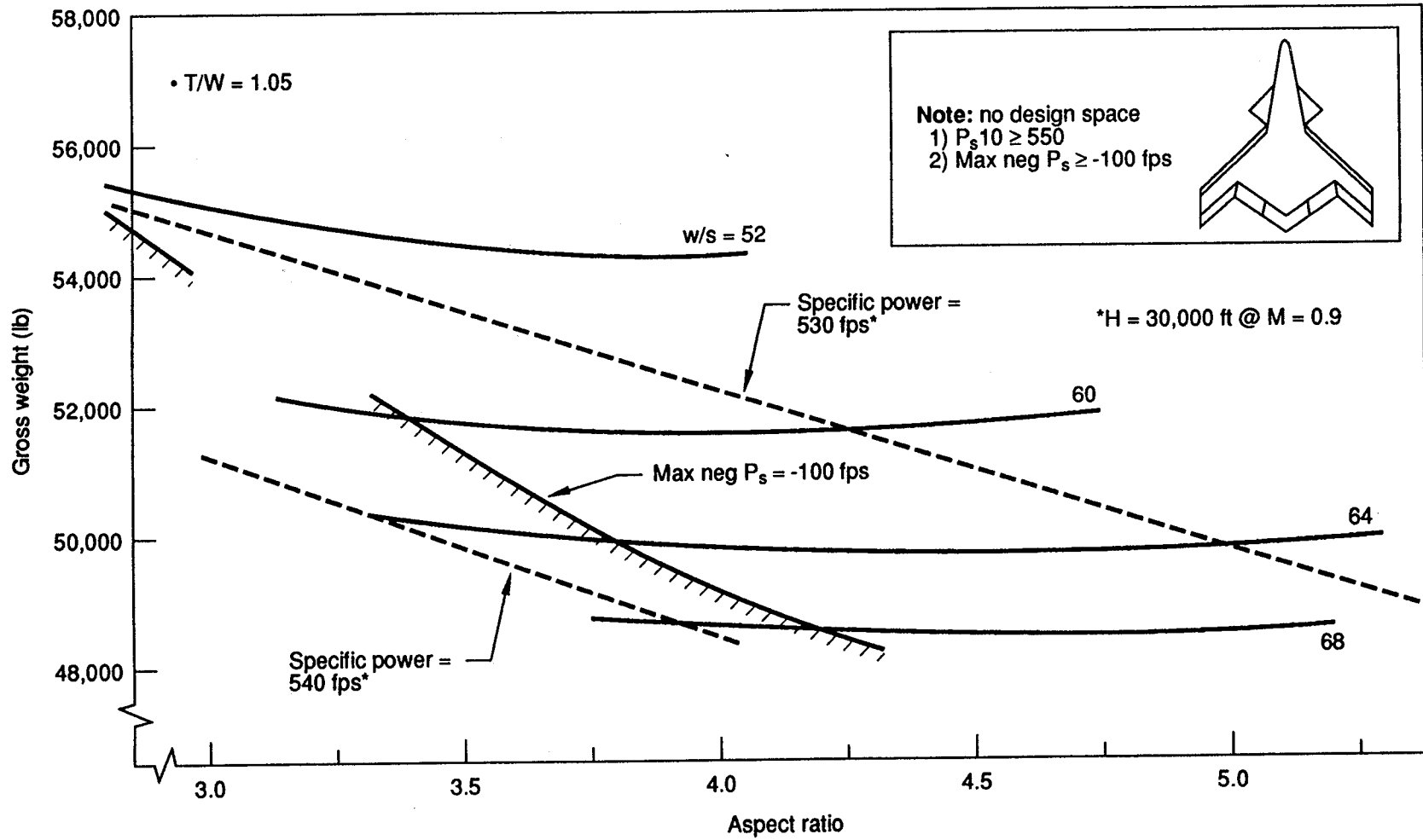

Figure 5.12. Multi-Role, High Agility Configuration Sizing Chart



To illustrate how the design space disappears at lower thrust levels, another sizing chart was constructed using a thrust-to-weight ratio of 1.05. Note how specific power constraint of 550 fps moves to lower gross weight designs and no design space remains.

### Medium Agility

The variation of aircraft gross weight with the significant design parameters and design constraint boundaries is illustrated on the configuration sizing chart on figure 5.13. The chart was constructed with a thrust-to-weight ratio of 1.1 which allows a small design space between the instantaneous load constraint of 9 g's (M = 30,000 ft at M = 0.9) and the specific power constraint of 550 fps (H = 30,000 ft at M = 0.9). The other twenty-four constraints are all satisfied. The selected configuration lies on the instantaneous load constraint of 9 g's at an aspect ratio of 3.6. A slight weight reduction is indicated at higher aspect ratios but there is a concern for flutter. Characteristics of this design are:

Wing loading = 51.5 psf  
Aspect ratio = 3.6  
Span = 62.6 ft.  
Leading edge sweep = 38 deg.  
Gross weight = 56,060 lb.

#### 5.2.4 Joint Service Customer

The original intention for showing the impact of customer on the aircraft designs was a two stage approach. The first stage was to fix the aircraft mission and maneuver performance capability and then grow the aircraft structurally until it met the structural requirements of a joint service customer. The second stage would then address the impact of carrier suitability, such as Launch and Recovery wind-over deck on aircraft size.

The result of the first stage structural growth is shown in Figure 5.14. This figure is a complete side by side comparison of the Air Force and Joint Service Design Weight Breakdowns enforcing the condition that both aircraft have the same mission and maneuver performance. In general the structural penalties associated with carrier suitability increased the aircraft empty weights 14 to 17 percent and the design takeoff gross weights 11 to 15 percent.

The span of wing panels outboard of the wing fold range from 17 to 25 feet making them difficult to handle below deck. All the designs except the multi-role designs exceed the 54,500 lb. zero payload/maximum fuel weight corresponding to the elevator limit required for efficient flight operations.

The Joint Service Air Interdiction Design already exceeds the 80,000 lb. launch weight of the A-3, largest aircraft to ever operate from an aircraft carrier.

Increasing the aircraft size further in response to launch, recovery, and single-engine rate-of-climb requirements is not a feasible approach. Instead, the 54,500 lb. elevator limit was used to define the maximum launch weight of the Joint Service Designs. The basis of comparing the Joint Service designs with their Air Force counterparts will be mission radius and maneuver performance.

Figure 5.13. Multi-Role, Medium Agility Configuration Sizing Chart

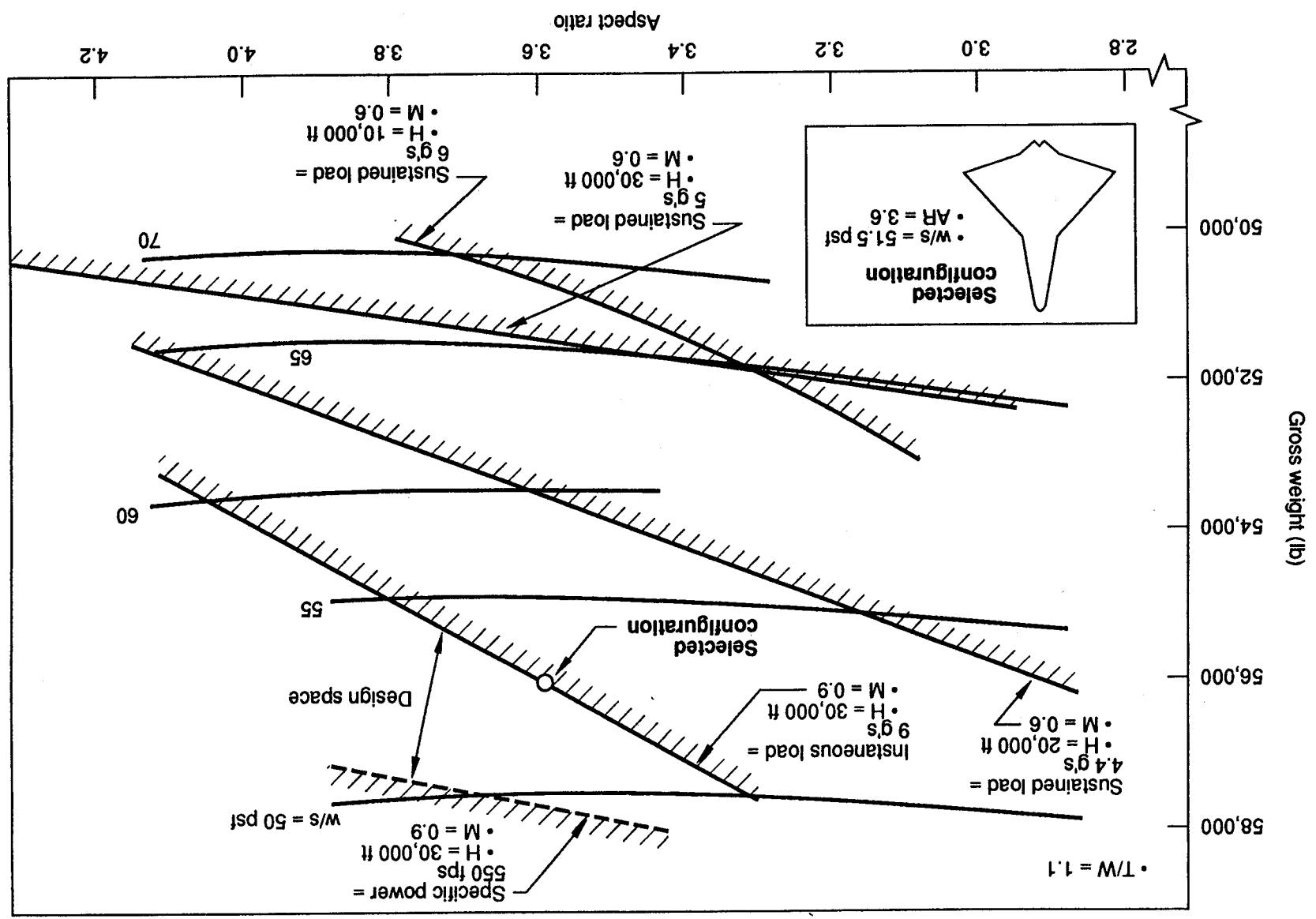

Design Mission		Air Interdiction		Multi-Role		Multi-Role		Air-To-Air		Air-to-Air	
		Low	Low	Moderate	Moderate	Low	Low	Moderate	Moderate	Low	Low
Observables Level		Moderate	Moderate	High	High	Moderate	Moderate	High	High	Moderate	Moderate
Agility Level		988-122	988-122N	988-119	988-119N	988-118	988-118N	988-115	988-115N	988-114	988-114N
Model Number		USAF	Joint	USAF	Joint	USAF	Joint	USAF	Joint	USAF	Joint
Service	Units										
Takeoff Gross Weight	lbs	73145	80910	48801	54704	50899	56947	59549	67397	65230	75312
Wing Reference Area	sq ft	1463	1618	830	931	1112	1244	1032	1167	1421	1641
Wing Span	ft	72	75	57	61	63	66	63	67	72	77
Folded Wing Span	ft	-	27	-	27	-	27	-	27	-	27
Takeoff T/W	-	0.34	0.34	1.10	1.10	1.10	1.10	1.13	1.13	1.13	1.13
Takeoff W/S	-	50	50	59	59	46	46	58	58	46	46
Wing Aspect Ratio	-	3.50	3.50	3.97	3.97	3.52	3.52	3.80	3.80	3.64	3.64
<b>Structures Group</b>											
Wing	lbs	8454	10287	6423	7920	6931	8530	6293	7835	9275	11779
Foreplane	lbs	-	-	408	457	-	-	634	718	-	-
Horizontal Tail	lbs	-	-	-	-	-	-	621	703	-	-
Body	lbs	8988	9437	6488	6812	7618	7999	8303	8718	9057	9510
Main Gear	lbs	1633	2489	1249	1929	1288	1986	1317	2054	1382	2199
Nose Gear	lbs	320	948	308	925	330	989	301	912	313	968
Air Induction	lbs	320	320	581	581	1145	1145	1088	1088	787	787
Engine Section	lbs	110	110	275	275	293	293	316	316	335	335
Yaw Vanes	lbs	675	747	294	330	294	329	294	333	374	432
<b>Total Structure</b>	<b>lbs</b>	<b>20500</b>	<b>24338</b>	<b>16026</b>	<b>19229</b>	<b>17899</b>	<b>21270</b>	<b>19167</b>	<b>22676</b>	<b>21523</b>	<b>26010</b>
<b>Propulsion Group</b>											
Engines	lbs	2044	2261	3100	3475	3352	3750	3660	4142	3934	4542
AMADS	lbs	200	200	200	200	200	200	200	200	200	200
Engine Controls	lbs	40	40	40	40	40	40	40	40	40	40
Starting System	lbs	80	80	80	80	80	80	80	80	80	80
Fuel System	lbs	1063	1176	1004	1125	1020	1141	1065	1205	1103	1273
Vectoring Nozzles	lbs	548	606	1529	1714	1412	1580	1532	1734	1631	1883
<b>Total Propulsion</b>	<b>lbs</b>	<b>3975</b>	<b>4363</b>	<b>5953</b>	<b>6634</b>	<b>6104</b>	<b>6791</b>	<b>6577</b>	<b>7402</b>	<b>6988</b>	<b>8019</b>
<b>Fixed Equipment</b>											
Flight Controls	lbs	1563	1729	1267	1420	1380	1544	1434	1623	1347	1555
APU	lbs	210	210	210	210	210	210	210	210	210	210
Instruments	lbs	270	270	270	270	270	270	270	270	270	270
Hydraulics	lbs	518	593	588	682	506	586	485	568	457	546
Electrical	lbs	627	627	618	618	618	618	688	688	690	690
Avionics	lbs	1700	1700	1700	1700	1700	1700	1569	1569	1569	1569
Armament	lbs	85	85	204	204	204	204	242	242	242	242
Furnishings and Equipment	lbs	371	386	371	386	371	386	371	386	371	386
Air Conditioning	lbs	640	640	659	659	658	658	713	713	712	712
Anti-Ice	lbs	10	10	10	10	10	10	10	10	10	10
Load and Handling	lbs	10	10	10	10	10	10	10	10	10	10
<b>Total Fixed Equipment</b>	<b>lbs</b>	<b>6004</b>	<b>6260</b>	<b>5907</b>	<b>6169</b>	<b>5937</b>	<b>6196</b>	<b>6002</b>	<b>6289</b>	<b>5888</b>	<b>6200</b>
<b>Weight Empty</b>	<b>lbs</b>	<b>30479</b>	<b>34961</b>	<b>27886</b>	<b>32033</b>	<b>29940</b>	<b>34257</b>	<b>31746</b>	<b>36367</b>	<b>34399</b>	<b>40229</b>
<b>Fixed Useful Load</b>											
Crew	lbs	215	215	215	215	215	215	215	215	215	215
Crew Equipment	lbs	40	40	40	40	40	40	40	40	40	40
Oil & Trapped Oil	lbs	100	111	100	112	100	112	100	113	100	115
Trapped Fuel	lbs	456	504	213	239	214	239	360	407	405	468
Gun Installation	lbs	243	243	252	252	252	252	252	252	252	252
Launchers/Ejectors	lbs	980	980	700	700	700	700	760	760	760	760
Ammo Cases	lbs	450	450	90	90	90	90	113	113	113	113
<b>Non-Expendable Useful Load</b>	<b>lbs</b>	<b>2484</b>	<b>2543</b>	<b>1610</b>	<b>1648</b>	<b>1611</b>	<b>1648</b>	<b>1840</b>	<b>1901</b>	<b>1885</b>	<b>1963</b>
<b>Operating Weight</b>	<b>lbs</b>	<b>32963</b>	<b>37504</b>	<b>29496</b>	<b>33681</b>	<b>31551</b>	<b>35906</b>	<b>33586</b>	<b>38268</b>	<b>36284</b>	<b>42192</b>
Missiles	lbs	9100	9100	4990	4990	4990	4990	1800	1800	1800	1800
Ammo Expendable	lbs	710	710	110	110	110	110	137	137	137	137
Fuel	lbs	30372	33596	14205	15923	14248	15941	24026	27192	27009	31184
<b>Design Takeoff Gross Weight</b>	<b>lbs</b>	<b>73145</b>	<b>80910</b>	<b>48801</b>	<b>54704</b>	<b>50899</b>	<b>56947</b>	<b>59549</b>	<b>67397</b>	<b>65230</b>	<b>75312</b>
<b>Zero Payload, Max Fuel Weight</b>	<b>lbs</b>	<b>-</b>	<b>71810</b>	<b>-</b>	<b>49714</b>	<b>-</b>	<b>51957</b>	<b>-</b>	<b>65597</b>	<b>-</b>	<b>73512</b>

Figure 5.14

Design Mission		Air Interdiction		Multi-Role		Multi-Role		Air-To-Air		Air-to-Air	
		Low	Low	Moderate	Moderate	Low	Low	Moderate	Moderate	Low	Low
		988-122	988-122N	988-119	988-119N	988-118	988-118N	988-115	988-115N	988-114	988-114N
Agility Level	Moderate	Moderate	High	High	Moderate	Moderate	High	High	Moderate	Moderate	
Model Number											
Service		USAF	Joint	USAF	Joint	USAF	Joint	USAF	Joint	USAF	Joint
	Units										
Takeoff Gross Weight	lbs	73145	63600	48801	59490	50899	59490	59549	56300	65230	56300
Wing Reference Area	sq ft	1463	1272	830	1012	1112	1300	1032	975	1421	1227
Wing Span	ft	72	67	57	63	63	68	63	61	72	67
Folded Wing Span	ft	-	27	-	27	-	27	-	27	-	27
Takeoff T/W	-	0.34	0.34	1.10	1.10	1.10	1.10	1.13	1.13	1.13	1.13
Takeoff W/S	-	50	50	59	59	46	46	58	58	46	46
Wing Aspect Ratio	-	3.50	3.50	3.97	3.97	3.52	3.52	3.80	3.80	3.64	3.64
<b>Structures Group</b>											
Wing	lbs	8454	8086	6423	8613	6931	8911	6293	6545	9275	8806
Foreplane	lbs	-	-	408	497	-	-	634	599	-	-
Horizontal Tail	lbs	-	-	-	-	-	-	621	587	-	-
Body	lbs	8988	9437	6488	6812	7618	7999	8303	8718	9057	9510
Main Gear	lbs	1633	1957	1249	2098	1288	2074	1317	1716	1382	1644
Nose Gear	lbs	320	745	308	1005	330	1033	301	762	313	723
Air Induction	lbs	320	320	581	581	1145	1145	1088	1088	787	787
Engine Section	lbs	110	110	275	275	293	293	316	316	335	335
Yaw Vanes	lbs	675	587	294	358	294	344	294	278	374	323
Total Structure	lbs	20500	21242	16026	20241	17899	21799	19167	20609	21523	22128
<b>Propulsion Group</b>											
Engines	lbs	2044	1777	3100	3779	3352	3918	3660	3460	3934	3395
AMADS	lbs	200	200	200	200	200	200	200	200	200	200
Engine Controls	lbs	40	40	40	40	40	40	40	40	40	40
Starting System	lbs	80	80	80	80	80	80	80	80	80	80
Fuel System	lbs	1063	740	1004	1328	1020	1251	1065	884	1103	773
Vectoring Nozzles	lbs	548	476	1529	1864	1412	1650	1532	1448	1631	1408
Total Propulsion	lbs	3975	3314	5953	7291	6104	7139	6577	6113	6988	5896
<b>Fixed Equipment</b>											
Flight Controls	lbs	1563	1359	1267	1545	1380	1613	1434	1356	1347	1163
APU	lbs	210	210	210	210	210	210	210	210	210	210
Instruments	lbs	270	270	270	270	270	270	270	270	270	270
Hydraulics	lbs	518	466	588	742	506	612	485	475	457	408
Electrical	lbs	627	627	618	618	618	618	688	688	690	690
Avionics	lbs	1700	1700	1700	1700	1700	1700	1569	1569	1569	1569
Armament	lbs	85	85	204	204	204	204	242	242	242	242
Furnishings and Equipment	lbs	371	386	371	386	371	386	371	386	371	386
Air Conditioning	lbs	640	640	659	659	658	658	713	713	712	712
Anti-Ice	lbs	10	10	10	10	10	10	10	10	10	10
Load and Handling	lbs	10	10	10	10	10	10	10	10	10	10
Total Fixed Equipment	lbs	6004	5763	5907	6353	5937	6291	6002	5928	5888	5670
<b>Weight Empty</b>	lbs	<b>30479</b>	<b>30319</b>	<b>27886</b>	<b>33885</b>	<b>29940</b>	<b>35229</b>	<b>31746</b>	<b>32651</b>	<b>34399</b>	<b>33694</b>
<b>Fixed Useful Load</b>											
Crew	lbs	215	215	215	215	215	215	215	215	215	215
Crew Equipment	lbs	40	40	40	40	40	40	40	40	40	40
Oil & Trapped Oil	lbs	100	70	100	132	100	123	100	83	100	70
Trapped Fuel	lbs	456	318	213	282	214	263	360	299	405	284
Gun Installation	lbs	243	243	252	252	252	252	252	252	252	252
Launchers/Ejectors	lbs	980	980	700	700	700	700	760	760	760	760
Ammo Cases	lbs	450	450	90	90	90	90	113	113	113	113
Non-Expendable Useful Load	lbs	2484	2315	1610	1711	1611	1682	1840	1762	1885	1734
<b>Operating Weight</b>	lbs	<b>32963</b>	<b>32635</b>	<b>29496</b>	<b>35596</b>	<b>31551</b>	<b>36911</b>	<b>33586</b>	<b>34413</b>	<b>36284</b>	<b>35428</b>
Missiles	lbs	9100	9100	4990	4990	4990	4990	1800	1800	1800	1800
Ammo Expendable	lbs	710	710	110	110	110	110	137	137	137	137
Fuel	lbs	30372	21155	14205	18794	14248	17479	24026	19950	27009	18935
<b>Design Takeoff Gross Weight</b>	lbs	<b>73145</b>	<b>63600</b>	<b>48801</b>	<b>59490</b>	<b>50899</b>	<b>59490</b>	<b>59549</b>	<b>56300</b>	<b>65230</b>	<b>56300</b>
Zero Payload, Max Fuel Weight	lbs	-	54500	-	54500	-	54500	-	54500	-	54500

Figure 5.15

Carrier Suitability

**Fully Mission Capable**

Configuration	Units	988-122	988-119	988-118	988-115	988-114
Aspect Ratio		3.5	4.	3.5	3.8	3.6
Wing Reference Area	sq ft	1618.	931.	1244.	1167.	1641.
LE SWeep	deg	49.	42.	38.	40.	48.
t/c@root		.08	.05	.05	.05	.05
CLmax		1.1	1.53	1.72	1.63	1.21
Launch Weight	lbs	80910.	54704.	56947.	67397.	75312.
C-13-1 Endspeed	kts	138.	154.	152.	146.	142.
Launch WOD Required	kts	-19.0	-43.9	-62.1	-41.2	-32.9
Operating Weight	lbs	37504.	33681.	35906.	38268.	42192.
Approach Weight	lbs	46504.	42681.	44906.	47268.	51192.
Powered Approach Stall Speed	kts	89.	96.	80.	87.	89.
Arresting Speed	kts	116.	125.	104.	113.	115.
Mk7Mod3 Engaging Speed	kts	136.	141.	138.	135.	129.
Recovery WOD Required	kts	-20.	-17.	-34.	-21.	-14.

**Reduced Mission Capability**

Configuration	Units	988-122	988-119	988-118	988-115	988-114
Aspect Ratio		3.5	4.	3.5	3.8	3.6
Wing Reference Area	sq ft	1272.	1012.	1300.	975.	1227.
LE SWeep	deg	49.	42.	38.	40.	48.
t/c@root		.08	.05	.05	.05	.05
CLmax		1.1	1.53	1.72	1.63	1.21
Launch Weight	lbs	63600.	59490.	59490.	56300.	56300.
C-13-1 Endspeed	kts	148.	151.	151.	153.	153.
Launch WOD Required	kts	-28.9	-41.2	-60.6	-47.6	-43.9
Operating Weight	lbs	32635.	35596.	36911.	34413.	35428.
Approach Weight	lbs	41635.	44596.	45911.	43413.	44428.
Powered Approach Stall Speed	kts	95.	94.	79.	91.	96.
Arresting Speed	kts	124.	122.	103.	119.	124.
Mk7Mod3 Engaging Speed	kts	143.	139.	137.	140.	139.
Recovery WOD Required	kts	-19.	-16.	-34.	-21.	-14.

Figure 5.16

## 6.0 Configuration and Performance Results

### Joint Service Usage

#### Configuration Issues

The general arrangements of each USAF concept for Models 988-115, -118, and -122/-123 embody basic features that permit incorporation of Joint Service unique items without voiding the design. These major unique items consist of carrier landing gear, arresting hook, and wing fold. Performance peculiar and mission resizing for zero fuel weight growth will impact size as a function of visibility required, and mission fuel increases required to perform the mission.

### USAF Service

#### Air Interdiction Concept

#### Configuration Description

The vehicle type is stipulated as a low observable configuration for both the medium and high agility performance conditions. Sizing iterations resulted in a decision to represent both vehicle types in one configuration arrangement with the only principal differences being engine thrust level and mission fuel required.

This vehicle, Model 988-122/-123, is a single-place, subsonic all flying wing design powered by twin low bypass engines of 13,865 pounds dry thrust each. Externally, the vehicle, shown in general arrangement drawing ASC988-122-1, is characterized by the moderately swept leading edge at 48.75 degrees, lower surface inlet apertures, full span trailing edge elevons, and upper surface thrust vectoring exhaust nozzles. The wing leading edge incorporates large powered slats that are used to achieve critical maneuver conditions.

Control effectors include the yaw thrust vectoring exhaust nozzles with  $\pm 45$  degrees of deflection, upper and low Yaw Vane pairs integrated with the nozzle and lower surface, and four elevons per semi-span. Elevons are single panel at the most outboard and inboard position, with the two mid-span panels being split on the wing reference plane.

The interior layout, shown on inboard profile drawing ASC 988-122-2, provides sufficient room for all functional systems and features required. Principal features are the deep (approximately 15% t/c) center section for weapons bay, fuel tankage, crew station and equipment installations, include 30mm gun system installation. Basic thickness ratio decreases to approximately 8.5% at the main landing gear and then to 5% in the outboard panel.

The propulsion installation occupies a bay full chord length for each engine. The inlet is pitot type with a slightly offset diffuser duct.

Exhaust system features for the non-augmented engine consist of the fully offset duct turning through a circular bearing/rotation plane to direct exhaust gas through the rotating nozzle exit plane. The exhaust nozzle is a fixed throat SERN type that utilizes the inboard upper surface as an expansion surface.

Fuel tankage in the outer wing panel is integral. Center section fuel tankage above the weapons bay has main tank volume allocated as bladder protected "get-home" fuel.

ROEDOUT FRAME /

7

8

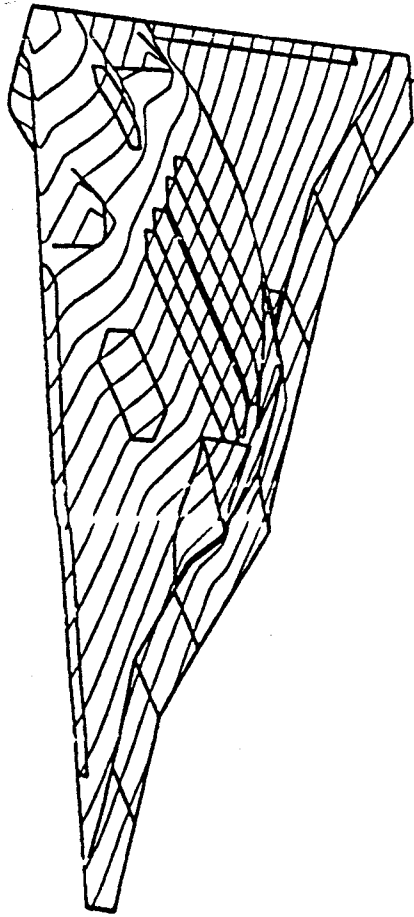

D

C

B

A

8

ORIGINAL PAGE IS  
OF POOR QUALITY

7

8





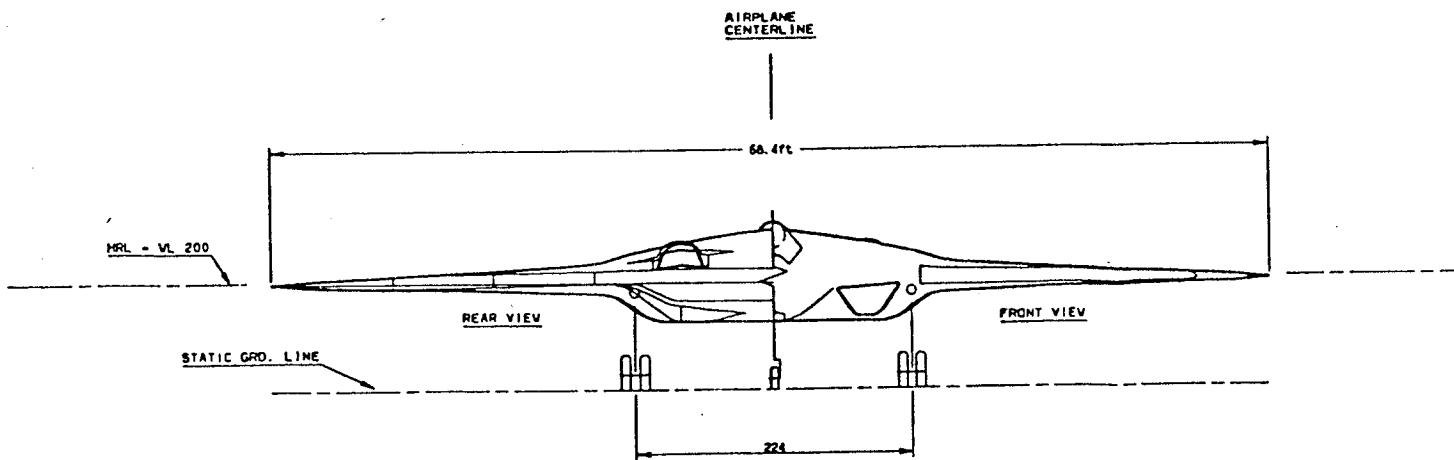
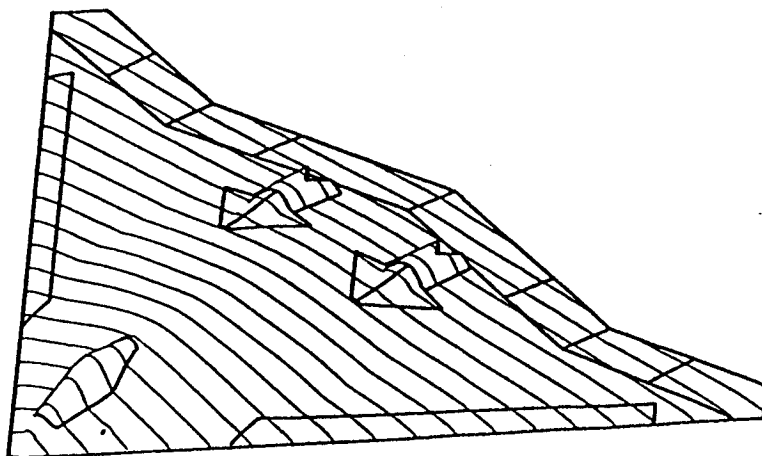

ORIGINAL PAGE IS OF POOR QUALITY

BOEING PROPRIETARY  
 THE INFORMATION CONTAINED HEREIN IS PROPRIETARY TO THE BOEING COMPANY  
 AND SHALL NOT BE REPRODUCED OR DISCLOSED IN WHOLE OR IN PART OR  
 USED FOR ANY PURPOSE EXCEPT UNDER SUCH USER POSSESSED DIRECT WRITTEN  
 AUTHORIZATION FROM THE BOEING COMPANY.

81205 ASC988-122-1







### FOLDOUT FRAME

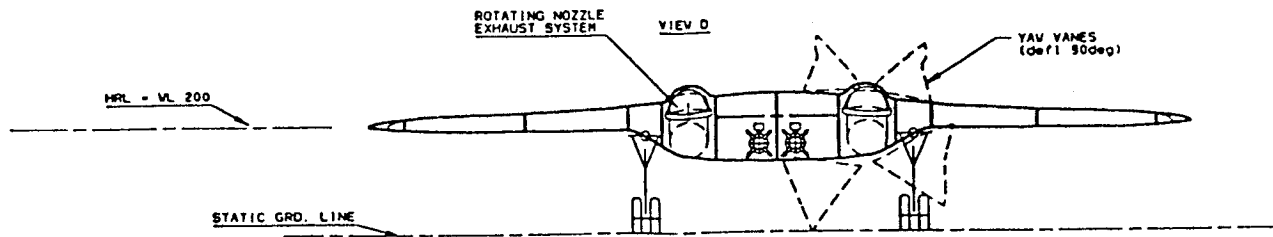
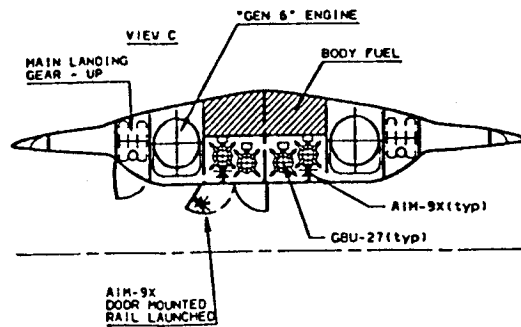
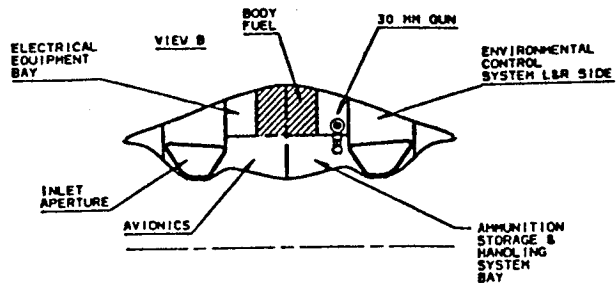
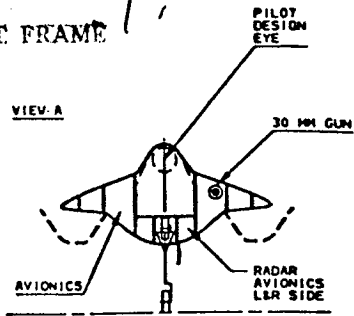

BOEING PROPRIETARY  
 THE INFORMATION CONTAINED HEREIN IS PROPRIETARY TO THE BOEING COMPANY  
 AND SHALL NOT BE REPRODUCED OR DISCLOSED IN WHOLE OR IN PART OR  
 USED FOR ANY PURPOSE EXCEPT WHEN SUCH USER POSSESSES DIRECT WRITTEN  
 AUTHORIZATION FROM THE BOEING COMPANY.

ASC988-122-2



BEING PROPRIETARY  
 THE INFORMATION CONTAINED HEREIN IS PROPRIETARY TO THE BOEING COMPANY  
 AND SHALL NOT BE REPRODUCED OR DISCLOSED IN WHOLE OR IN PART OR  
 USED FOR ANY PURPOSES EXCEPT WITH THE WRITTEN PERMISSION DIRECT WRITTEN  
 AUTHORIZATION FROM THE BOEING COMPANY.

REVISED  
 REVISION NO. 1  
 DATE 10/10/88

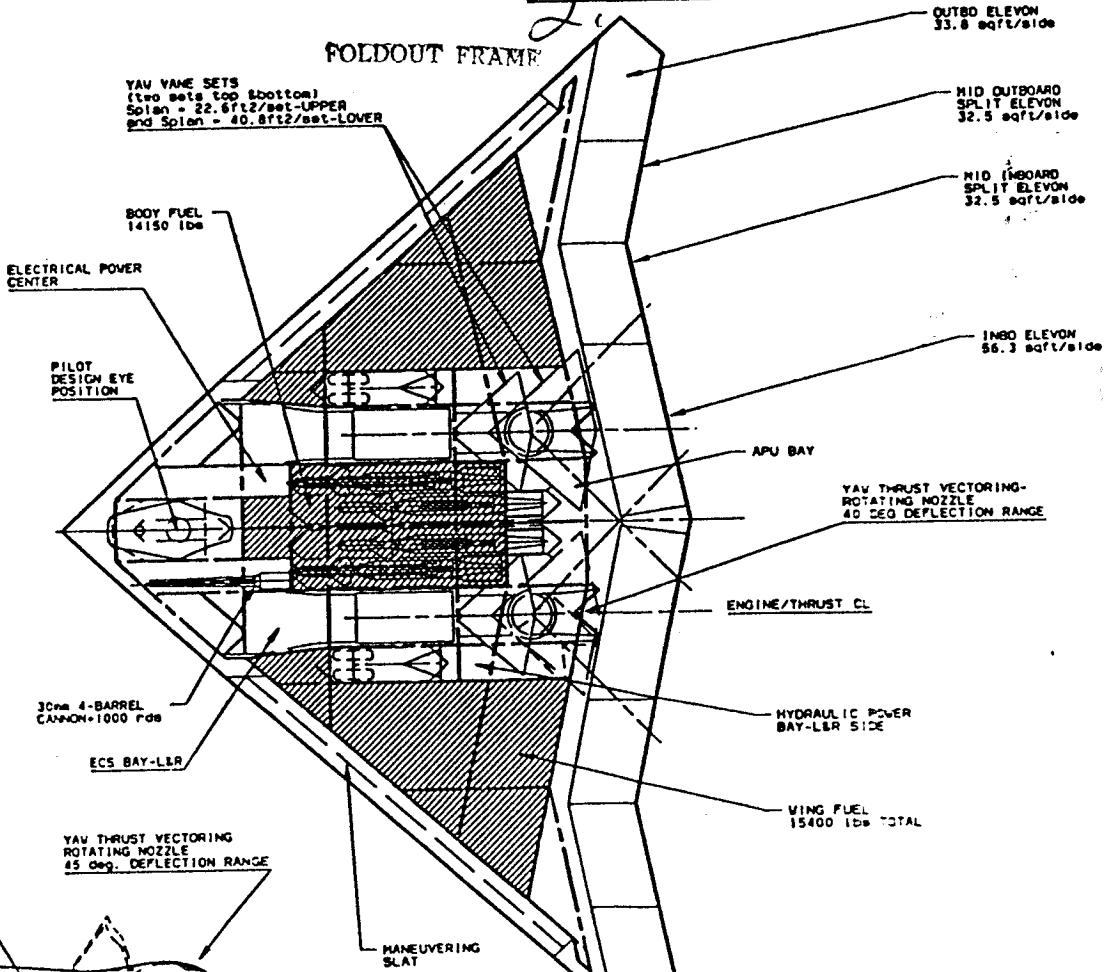

ENGINE - "GEN 6" TECHNOLOGY  
 Fals-13865lbs (DRY - each)

YAW THRUST VECTORING  
 ROTATING NOZZLE  
 45 DEG. DEFLECTION RANGE

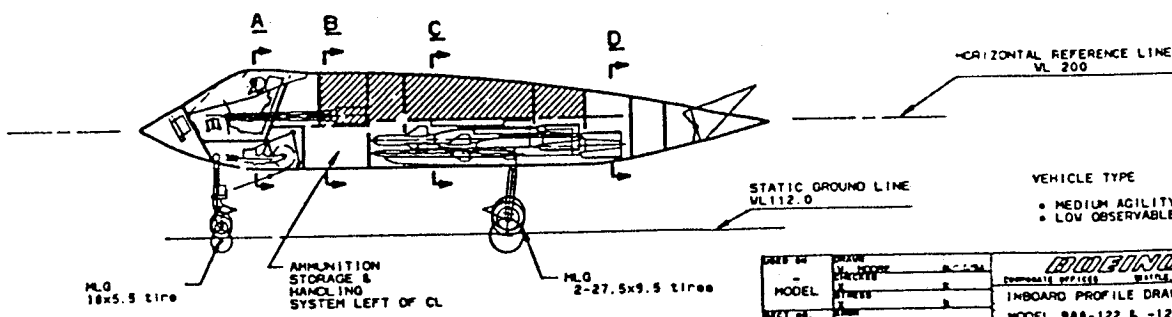
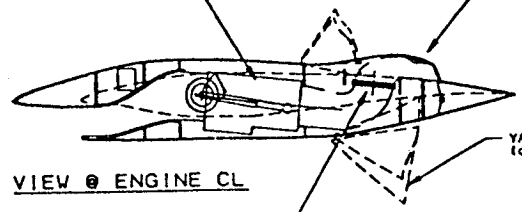

DATE	BY	CHKD	APP'D	REV	DESCRIPTION
MODEL					INBOARD PROFILE DRAWING
REV	X				MODEL 988-122 & -123
DESIGNER	D. E. RUIZICKA				AIR INTERDICTION CONFIG.
GROUP					
CONFIRMATION					
SCALE	J 01285				ASC988-122-2
CONF ID					SCALE 1/100 DIA 1

104





<b>GROUP WEIGHT STATEMENT</b>			
MISSION: Air-to-Ground	<b>WEIGHT (LB)</b>	NOSE STATION	0 IN
MODEL: 988-123 HiA/LO		WING MAC	320 IN
		LEMAC	159 IN
		BODY LENGTH	518 IN
		<b>BODY STATION</b>	<b>PERCENT MAC</b>
WING	8454	320	
BODY	8988	250	
MAIN GEAR	1633	302	
NOSE GEAR	320	69	
AIR INDUCTION	320	142	
ENGINE SECTION	110	291	
YAW VANES	675	395	
<b>TOTAL STRUCTURE</b>	<b>20500</b>	<b>283</b>	
ENGINES	2044	291	
AMADS	200	218	
ENGINE CONTROLS	40	195	
STARTING SYSTEM	80	248	
FUEL SYSTEM	1063	274	
VECTORIZING NOZZLES	548	383	
<b>TOTAL PROPULSION</b>	<b>3975</b>	<b>293</b>	
FLIGHT CONTROLS	1563	371	
APU	210	380	
INSTRUMENTS	270	105	
HYDRAULICS	518	296	
ELECTRICAL	627	184	
AVIONICS	1700	168	
ARMAMENT	85	120	
FURNISHINGS & EQUIPMENT	371	180	
AIR CONDITIONING	640	172	
ANTI-ICE	10	172	
LOAD AND HANDLING	10	286	
<b>TOTAL FIXED EQUIPMENT</b>	<b>6004</b>	<b>239</b>	
<b>WEIGHT EMPTY</b>	<b>30479</b>	<b>276</b>	<b>36.4%</b>
CREW	215	100	
CREW EQUIPMENT	40	100	
OIL & TRAPPED OIL	100	253	
TRAPPED FUEL	456	274	
GUN INSTALLATION	243	170	
LAUNCHERS/EJECTORS	980	299	
AMMO CASES	450	175	
<b>NON-EXP USEFUL LOAD</b>	<b>2484</b>	<b>237</b>	
<b>OPERATING WEIGHT</b>	<b>32963</b>	<b>273</b>	<b>35.5%</b>
MISSILES	9100	306	
AMMO EXPENDABLE	710	175	
FUEL	30372	274	
<b>GROSS WEIGHT</b>	<b>73145</b>	<b>275</b>	<b>36.1%</b>

11	WEIGHT	%Fuel	Payload	DeltaF	Pset	Mach	Altitude	Mach	Altitude	Require	Actual
POT	29417.50	0.00	0.00	0.00	0.00	0.00	0.00	0.00	0.00	1.30	2.06
LOADAG	63145.92	0.60	11000.00	0.00	1.00	0.80	0.00	0.00	0.00	6.50	6.60
LOADAG	63145.92	0.60	11000.00	0.00	1.00	0.80	0.00	0.00	0.00	9.00	9.00
axRC	63145.92	0.60	11000.00	0.00	1.00	0.00	40000.00	0.00	0.00	500.00	1167.58
CCEIAG	62818.91	0.60	11000.00	0.00	1.00	0.45	0.00	0.00	0.83	60.00	52.00
-13-1	75379.10	1.00	11000.00	0.00	1.00	0.80	40000.00	0.00	1.50	0.00	3.58
EROC	75379.10	1.00	11000.00	0.00	1.00	0.80	40000.00	0.00	1.50	0.00	-822.62
K7MOD3	53265.92	0.60	1120.00	0.00	1.00	0.80	40000.00	0.00	1.50	0.00	-1.25
EROC	65499.10	1.00	1120.00	0.00	1.00	0.80	40000.00	0.00	1.50	0.00	-979.78
xNegPs	63145.92	0.60	11000.00	0.00	1.00	0.68	0.00	0.00	0.00	-100.00	-57.76

<-----Initial----->><-----Final----->

<b>GROUP WEIGHT STATEMENT</b>			
MISSION: Air-to-Ground	WEIGHT (LB)	NOSE STATION	0 IN
MODEL: 988-122 MedA/LO		WING MAC	320 IN
		LEMAC	159 IN
		BODY LENGTH	518 IN
		BODY STATION	PERCENT MAC
WING	8454	320	
BODY	8988	250	
MAIN GEAR	1633	302	
NOSE GEAR	320	69	
AIR INDUCTION	320	142	
ENGINE SECTION	110	291	
YAW VANES	675	395	
<b>TOTAL STRUCTURE</b>	<b>20500</b>	<b>283</b>	
ENGINES	2044	291	
AMADS	200	218	
ENGINE CONTROLS	40	195	
STARTING SYSTEM	80	248	
FUEL SYSTEM	1063	274	
VECTERING NOZZLES	548	383	
<b>TOTAL PROPULSION</b>	<b>3975</b>	<b>293</b>	
FLIGHT CONTROLS	1563	371	
APU	210	380	
INSTRUMENTS	270	105	
HYDRAULICS	518	296	
ELECTRICAL	627	184	
AVIONICS	1700	168	
ARMAMENT	85	120	
FURNISHINGS & EQUIPMENT	371	180	
AIR CONDITIONING	640	172	
ANTI-ICE	10	172	
LOAD AND HANDLING	10	286	
<b>TOTAL FIXED EQUIPMENT</b>	<b>6004</b>	<b>239</b>	
<b>WEIGHT EMPTY</b>	<b>30479</b>	<b>276</b>	<b>36.4%</b>
CREW	215	100	
CREW EQUIPMENT	40	100	
OIL & TRAPPED OIL	100	253	
TRAPPED FUEL	456	274	
GUN INSTALLATION	243	170	
LAUNCHERS/EJECTORS	980	299	
AMMO CASES	450	175	
<b>NON-EXP USEFUL LOAD</b>	<b>2484</b>	<b>237</b>	
<b>OPERATING WEIGHT</b>	<b>32963</b>	<b>273</b>	<b>35.5%</b>
MISSILES	9100	306	
AMMO EXPENDABLE	710	175	
FUEL	30372	274	
<b>GROSS WEIGHT</b>	<b>73145</b>	<b>275</b>	<b>36.1%</b>

Nose @ BS 0  
 LEMAC @ BS 159.37  
 MAC Length = 320.31 in.  
 AC @ 35.94% MAC

**C.G. MOVEMENT RELATIONSHIP  
 TO AIRCRAFT WEIGHT**

Model 988-122 MedA/LO

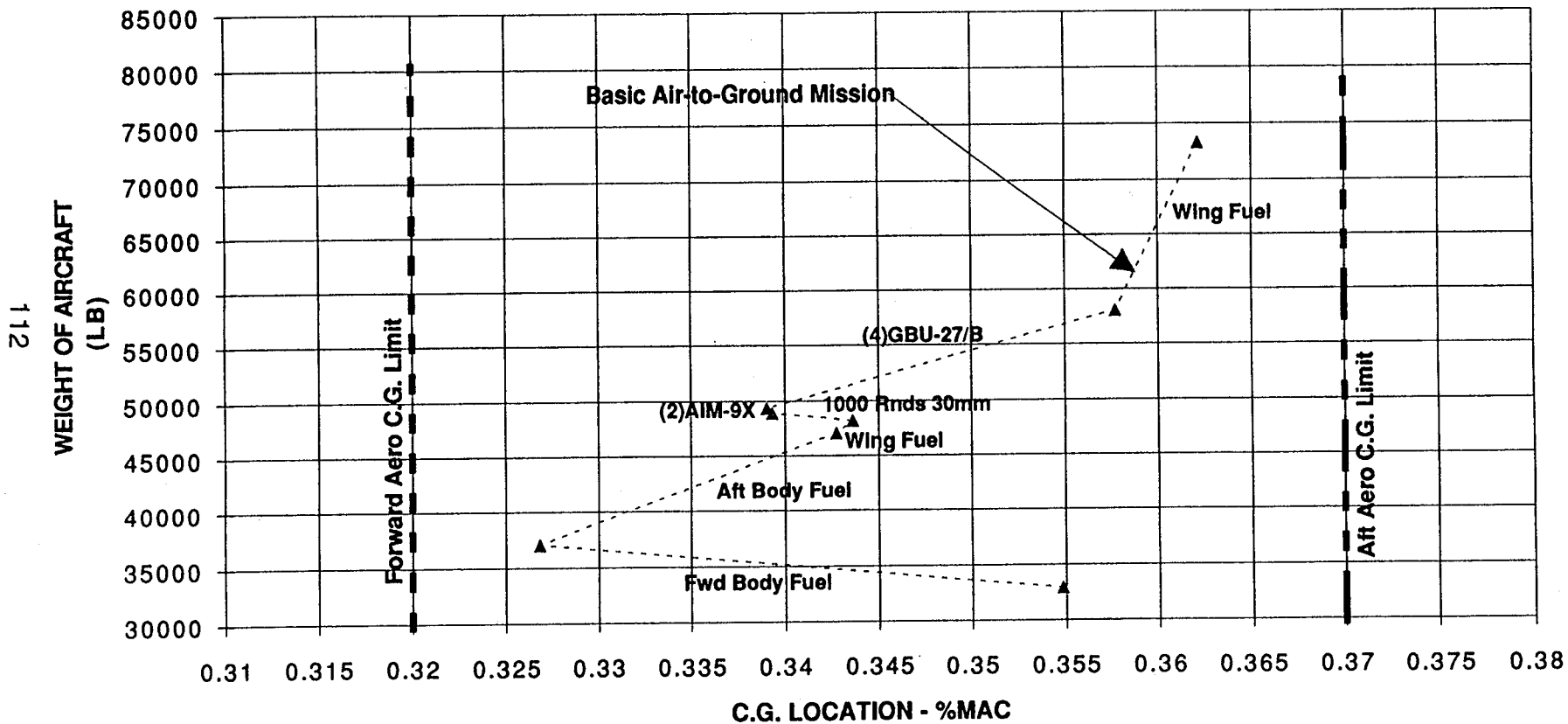

### Inertia Data at Combat Weight

		<b>A/G Model</b>
<b>Parameter</b>	<b>Units</b>	<b>988-122</b>
		<b>MedA/LO</b>
<b>Combat Weight</b>	<b>lbs</b>	<b>58506</b>
<b>Longitudinal C.G. (Body Sta)</b>	<b>in.</b>	<b>274</b>
<b>Vertical C.C. (from static ground line)</b>	<b>in.</b>	<b>80</b>
<b>Ixx Roll Inertia</b>	<b>slug-ft<sup>2</sup></b>	<b>182307</b>
<b>Iyy Pitch Inertia</b>	<b>slug-ft<sup>2</sup></b>	<b>92317</b>
<b>Izz Yaw Inertia</b>	<b>slug-ft<sup>2</sup></b>	<b>293526</b>
<b>Ixz Product of Inertia</b>	<b>slug-ft<sup>2</sup></b>	<b>973</b>

## 6.2 Air Superiority Concepts

### Model 988-115, High Agility - Moderate Observables

The high agility, moderate observables vehicle, Model 988-115, is a single place, three-surface supersonic design powered by two turbojet engines of 33,660 pounds augmented thrust each. Externally the vehicle general arrangement, shown on drawing ASC 988-115-1, includes a lifting canard or foreplane ahead of the main wing and a horizontal tail aft of main wing.

Each surface (wing/canard/tail), is of identical planform with forty (40) degrees leading edge sweep. The canard and tail are identical plan areas and the canard is set at +10 degrees dihedral, with the wing and tail set at -5 degrees relative to the horizontal reference plane.

Inlets are integrated/nested with the lower forebody, inboard of canard deflection path. Exhaust nozzles are located side-by-side on the upper aft fuselage and Yaw Vane pairs are integrated with the nozzles and on the lower aft body.

Control effectors include the yaw thrust vectoring exhaust nozzles, with  $\pm 40$  degrees of deflection, the Yaw Vane pairs above and below aft fuselage, and main wing trailing edge plain flaps, in addition to the canard and horizontal tail.

Initial sizing optimizations for the high agility metric conditions resulted in main wing size and aspect ratio which established overall span at a size that was considered impractical to achieve in a high agility fighter. The approach taken was to extract the equivalent horizontal tail exposed area from the theoretical main wing and incorporate a lifting canard/foreplane. This arrangement replicates that currently in use on the F-15/SMTD research vehicle.

The interior layout, shown on inboard profile drawing ASC 988-115-2, accommodates the crew, subsystem, weapons and propulsion system volume allocations within a low profile body shape. The forebody is conventional in arrangement and includes avionics, crew station, gun system, and avionics subsystem. Center body contents are main fuel tanks, inlet system, weapons bay, and main landing gear. The aft body provides engine and exhaust system accommodation.

Propulsion system installation features consist of the nested external compression fixed ramp inlet, long vertical offset inlet diffuser running over the weapons bay to engine face.

The exhaust system includes augmentor spray bars, fully offset duct to nozzle exit plane. The duct turns through a circular bearing/rotation plane to direct exhaust gas out the nozzle aperture. A significant and challenging risk issue is presented here in this concept of making the rotating nozzle system augmentor capable. A discussion of this issue is contained in Section 7.0, Areas of High Technical Risk.

Nozzle concept is that of a variable throat SERN type that utilizes the upper aft deck as the expansion surface.

Fuel tankage in the main wing panel is integral and center section tankage contains fuel in conventional bladder cells.

FOLDOUT FRAME

NOT

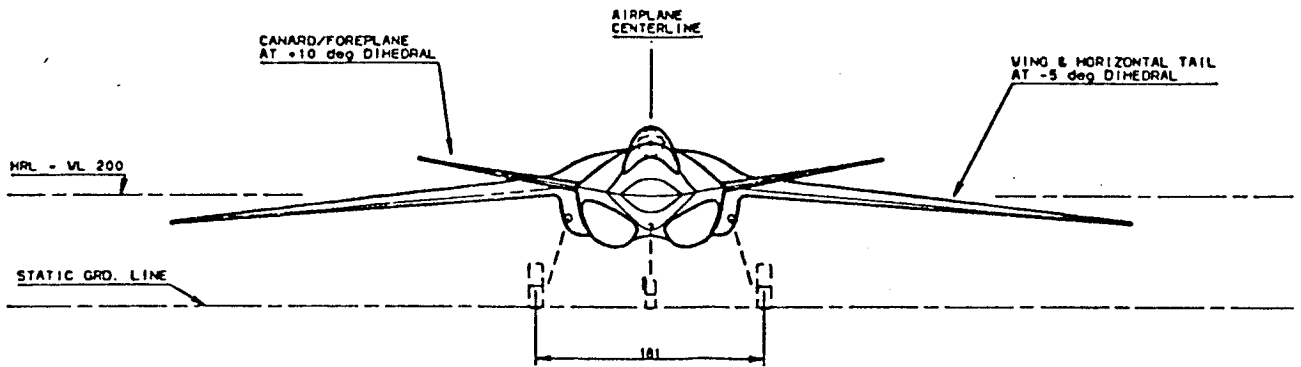

BOEING PROPRIETARY  
THE INFORMATION CONTAINED HEREIN IS PROPRIETARY TO THE BOEING  
AND SHALL NOT BE REPRODUCED OR DISCLOSED IN WHOLE OR IN PART  
USED FOR ANY PURPOSE EXCEPT UNDER SUCH USER POSSESSES DIRECT  
AUTHORIZATION FROM THE BOEING COMPANY.









FOLDOUT FRAME

NOT

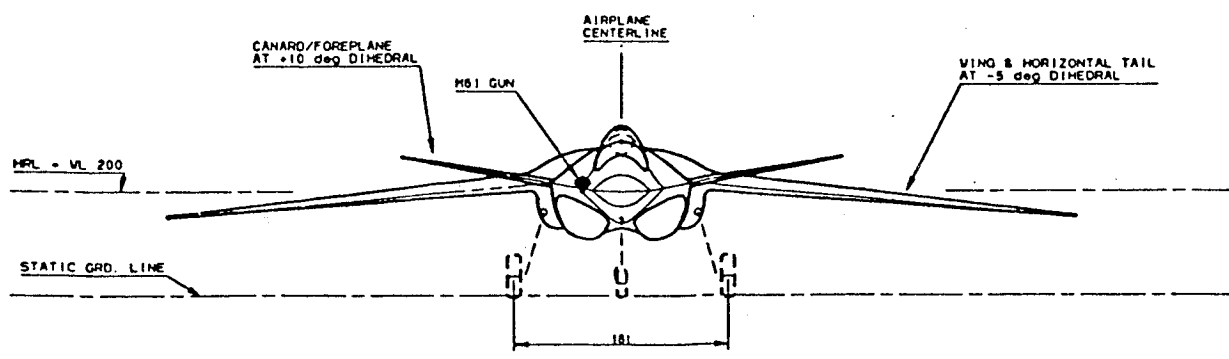

BOEING PROPRIETARY  
 THE INFORMATION CONTAINED HEREIN IS PROPRIETARY TO THE BOEING COMPANY AND SHALL NOT BE REPRODUCED OR DISCLOSED IN WHOLE OR IN PART UNLESS FOR ANY PURPOSES EXCEPT WHEN SUCH USE HAS BEEN GRANTED DIRECT AUTHORIZATION FROM THE BOEING COMPANY.



BEING PROPRIETARY  
 THE INFORMATION CONTAINED HEREIN IS PROPRIETARY TO THE GOVT.  
 AND SHALL NOT BE REPRODUCED OR DISCLOSED IN ANY MANNER OR IN ANY  
 FORM FOR ANY PURPOSE EXCEPT WHEN SUCH USER POSSESSES DIRECT  
 AUTHORIZATION FROM THE GOVT. COMPANY.

DEL 988-115

WING, HORIZ & CANARD  
 ARE SHOWN IN TRUE PLAN VIEW  
 AND ARE IN PLANE OF SURFACE

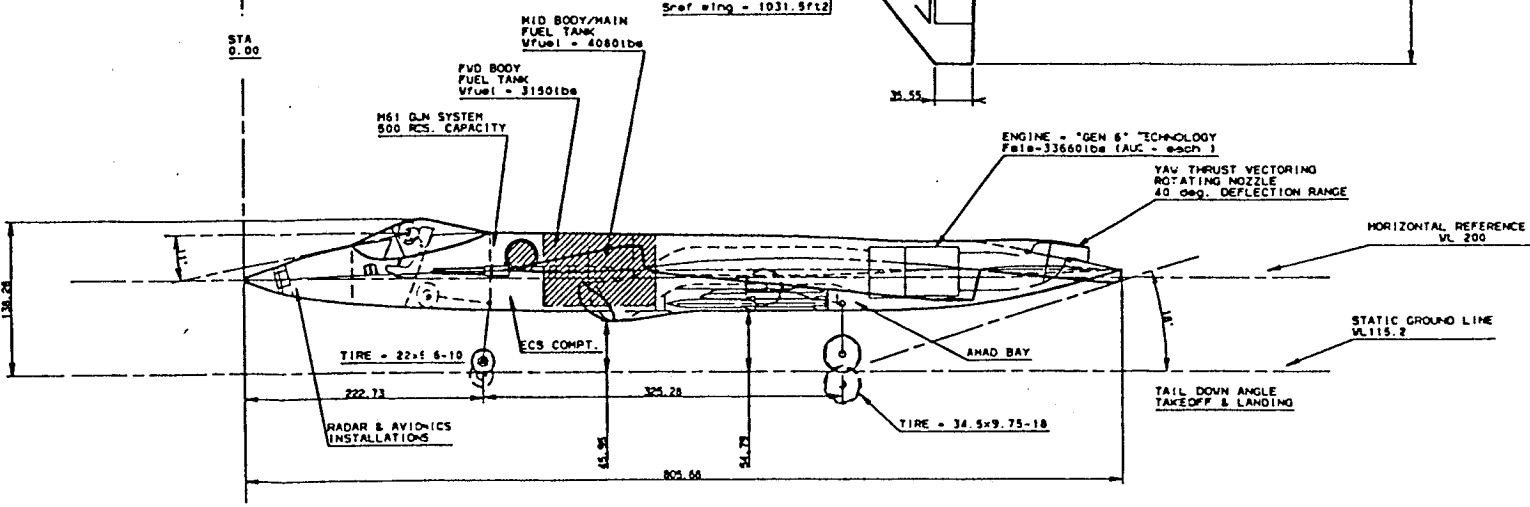
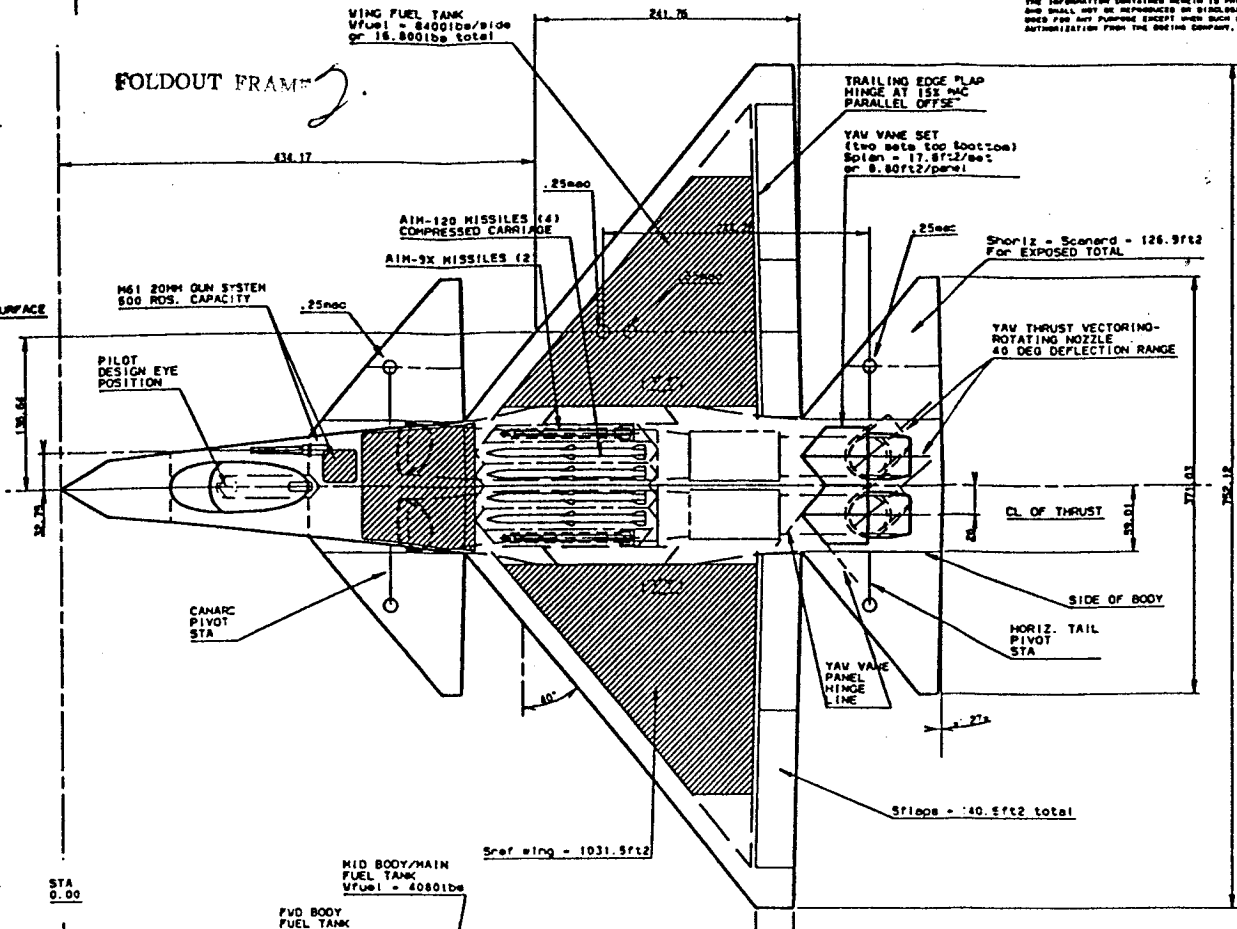

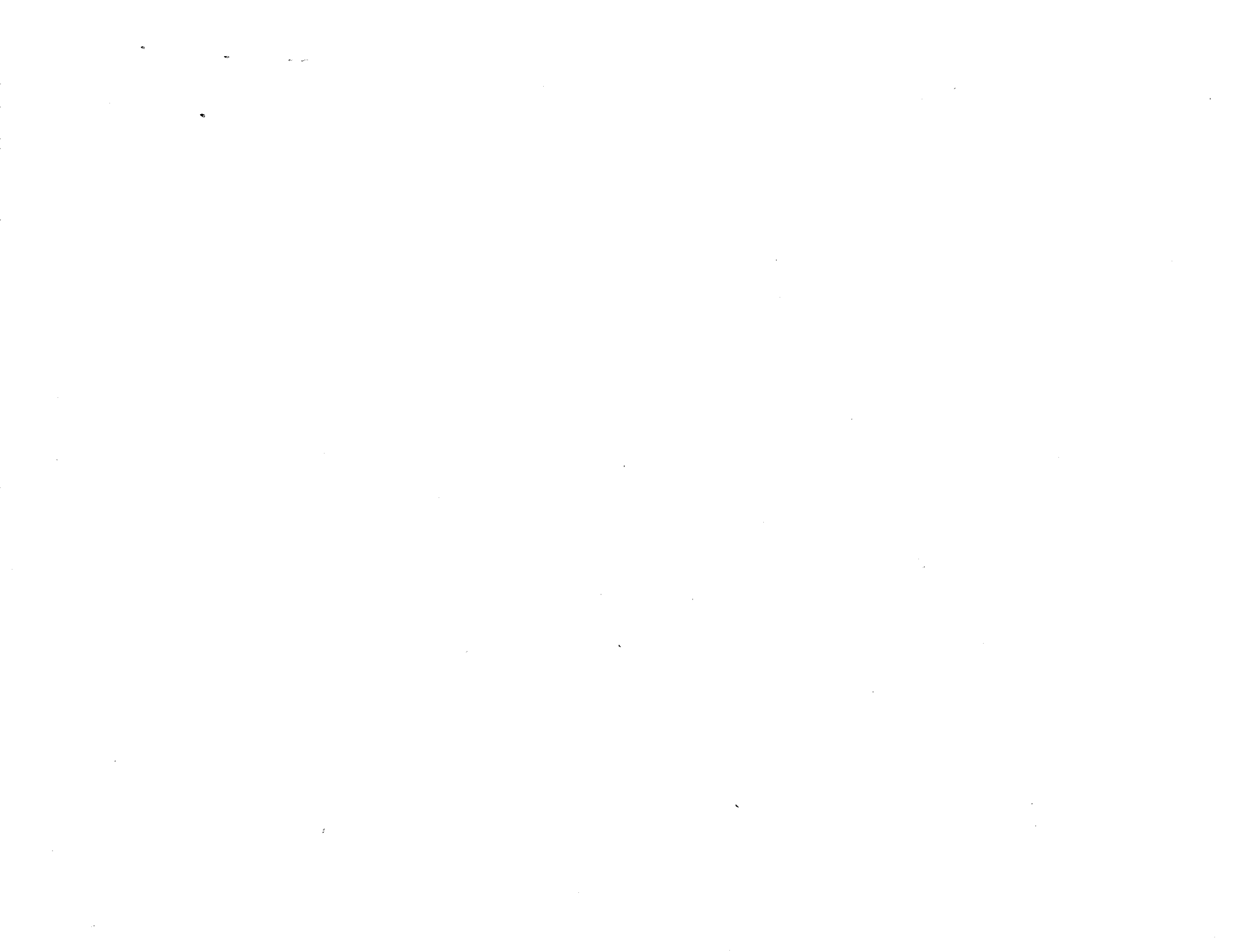

<b>GROUP WEIGHT STATEMENT</b>			
MISSION: Air-to-Air	WEIGHT (LB)	NOSE STATION	0 IN
MODEL: 988-115 HiA/ModLO		WING MAC	242 IN
		LEMAC	434 IN
		BODY LENGTH	806 IN
		BODY STATION	PERCENT MAC
WING	6293	550	
HORIZONTAL TAIL	621	760	
YAW VANES	294	705	
BODY	8303	468	
MAIN GEAR	1317	549	
NOSE GEAR	301	212	
AIR INDUCTION	1088	410	
ENGINE SECTION	316	625	
FOREPLANE	634	312	
<b>TOTAL STRUCTURE</b>	<b>19167</b>	<b>504</b>	
ENGINES	3660	625	
AMADS	200	550	
ENGINE CONTROLS	40	389	
STARTING SYSTEM	80	580	
FUEL SYSTEM	1065	504	
VECTORING NOZZLES	1532	730	
<b>TOTAL PROPULSION</b>	<b>6577</b>	<b>626</b>	
FLIGHT CONTROLS	1434	585	
APU	210	680	
INSTRUMENTS	270	158	
HYDRAULICS	485	587	
ELECTRICAL	688	436	
AVIONICS	1569	200	
ARMAMENT	242	228	
FURNISHINGS & EQUIPMENT	371	264	
AIR CONDITIONING	713	410	
ANTI-ICE	10	120	
LOAD AND HANDLING	10	468	
<b>TOTAL FIXED EQUIPMENT</b>	<b>6002</b>	<b>396</b>	
<b>WEIGHT EMPTY</b>	<b>31746</b>	<b>509</b>	<b>30.8%</b>
CREW	215	153	
CREW EQUIPMENT	40	153	
OIL & TRAPPED OIL	100	590	
TRAPPED FUEL	360	504	
GUN INSTALLATION	252	228	
LAUNCHERS/EJECTORS	760	460	
AMMO CASES	113	228	
<b>NON-EXP USEFUL LOAD</b>	<b>1840</b>	<b>387</b>	
<b>OPERATING WEIGHT</b>	<b>33587</b>	<b>502</b>	<b>28.1%</b>
MISSILES	1800	460	
AMMO EXPENDABLE	137	228	
FUEL	24026	504	
<b>GROSS WEIGHT</b>	<b>59550</b>	<b>500</b>	<b>27.4%</b>

Nose @ BS 0  
LEMAC @ BS 434.17  
MAC Length = 241.76 In.  
AC @ 30.0% MAC

**C.G. MOVEMENT RELATIONSHIP  
TO AIRCRAFT WEIGHT**

Model 988-115 HIA/MedLO

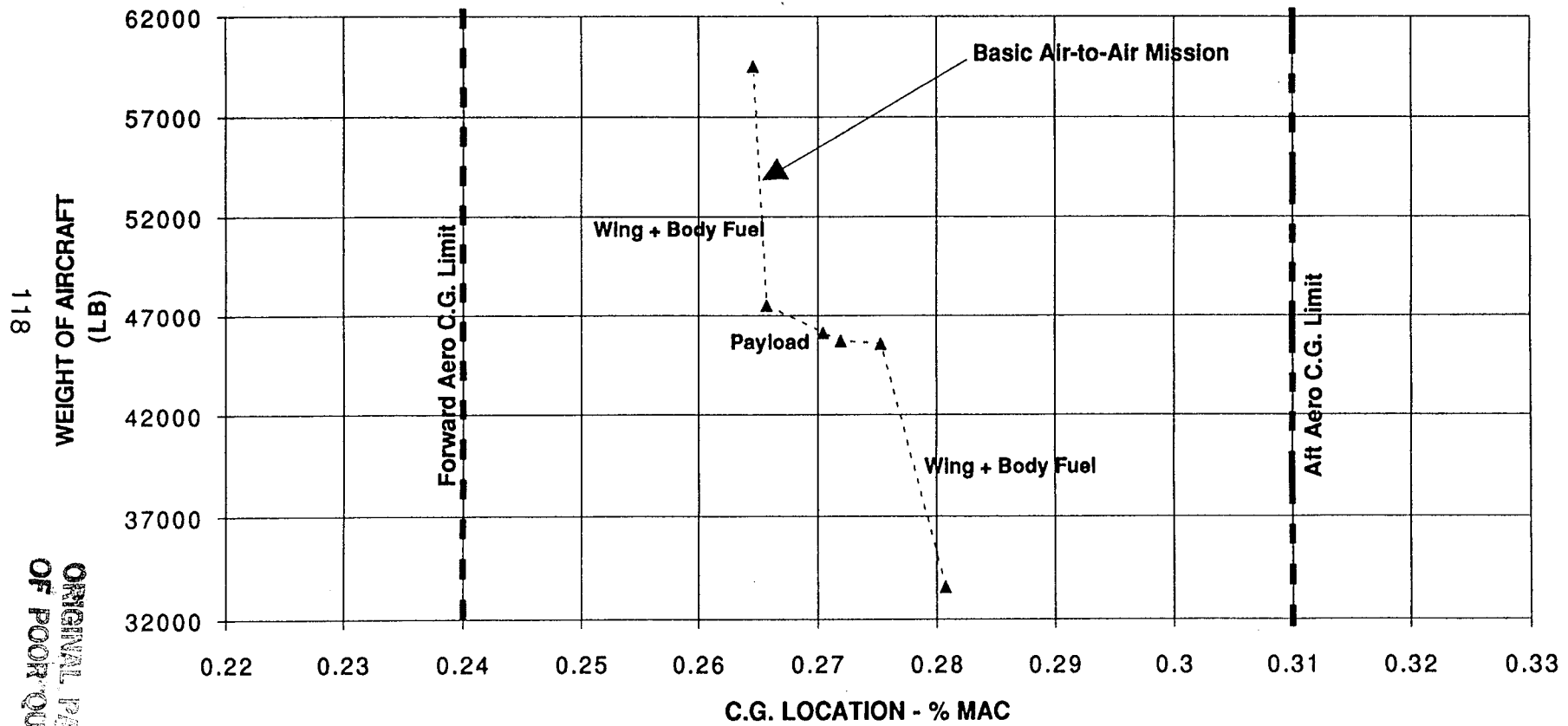



### Inertia Data at Combat Weight

		A/A Model
Parameter	Units	988-115
		HiA/ModLO
Combat Weight	lbs	47540
Longitudinal C.G. (Body Sta)	in.	498
Vertical C.C. (from static ground line)	in.	87
Ixx Roll Inertia	slug-ft <sup>2</sup>	84951
Iyy Pitch Inertia	slug-ft <sup>2</sup>	240255
Izz Yaw Inertia	slug-ft <sup>2</sup>	329116
Ixz Product of Inertia	slug-ft <sup>2</sup>	2137

Weight Statement	Weight (LBS)	Weight Fraction	Volume (cu ft)	CG (ft)	Moment (ft/lb)
<b>Airframe Structure</b>					
Fuselage.....	9117.	0.1549	91.	39.40	359236.
Wing.....	5144.	0.0874	51.	44.89	230929.
Canard.....	0.	0.0000	0.	0.00	0.
Horizontal Tail.....	618.	0.0105	6.	0.00	0.
Vertical Tail(s).....	205.	0.0035	2.	0.00	0.
Engine Mounts.....	300.	0.0051	3.	62.70	18816.
Inlet(s) and Duct(s).....	1192.	0.0203	82.	60.51	72155.
Exhaust Duct(s).....	0.	0.0000	7.	0.00	0.
Pivots.....	0.	0.0000	0.	0.00	0.
Main Landing Gear.....	1260.	0.0214	47.	40.56	51113.
Nose Gear.....	309.	0.0053	15.	25.32	7829.
Total	18145.	0.3083	306.	40.79	740077.
<b>Propulsion System</b>					
Engine(s) and Nozzle(s).....	5731.	0.0974	4.	62.70	359338.
Engine Start and Control.....	120.	0.0020	2.	36.98	2219.
Fuel Tanks.....	280.	0.0048	32.	38.27	10729.
Fuel Pumps.....	91.	0.0016	2.	38.27	3494.
Fuel Distribution System.....	531.	0.0090	13.	38.27	20322.
Air-Refueling System.....	75.	0.0013	2.	38.27	2870.
Fuel Inerting System.....	75.	0.0013	2.	38.27	2876.
Gear Box and Accessories.....	200.	0.0034	5.	62.70	12540.
Total	7104.	0.1207	62.	58.33	414388.
<b>Fixed Equipment</b>					
Instruments.....	270.	0.0046	7.	28.12	7591.
Surface Controls.....	1433.	0.0244	36.	38.27	54841.
Crew Accomodations.....	371.	0.0063	70.	22.43	8321.
Armaments.....	1012.	0.0172	34.	38.27	38729.
Avionics.....	1569.	0.0267	30.	26.86	42130.
Electrical System.....	622.	0.0106	16.	23.19	14423.
Hydraulics and Pneumatics.....	391.	0.0066	10.	35.18	13740.
Radar Absorpton Material.....	0.	0.0000	0.	0.00	0.
Auxiliary Power System.....	210.	0.0036	7.	0.00	0.
Airconditioning and De-Icing....	584.	0.0099	29.	12.06	7038.
Total	6461.	0.1098	238.	28.91	186814.
Empty Weight.....	31710.	0.5389	0.	42.30	*****
<b>Operational Items</b>					
Crew.....	255.	0.0043	4.	11.25	2869.
Trapped Fuel and Oil.....	441.	0.0075	9.	50.48	22281.
Gun and Provisions.....	365.	0.0062	7.	0.00	0.
Operational Empty Weight.....	32771.	0.5569	0.	0.00	0.
<b>Payload</b>					
Ammunition.....	137.	0.0023	5.	0.00	0.
Air-to-Air Missles.....	1800.	0.0306	95.	0.00	0.
Air-to-Ground Munitions.....	0.	0.0000	240.	38.27	0.
Total	1937.	0.0329	340.	0.00	0.
<b>Mission Fuel</b>					
Wing Fuel.....	12645.	0.2149	260.	0.00	0.
Body Fuel.....	11492.	0.1953	236.	0.00	0.
External Fuel.....	0.	0.0000	0.		
Design Gross Weight.....	58845.	1.0000	2091.	38.27	*****

988-115-A  
 M=1.0  
 □ Total  
 □ Body  
 □ Horiz  
 (Station)

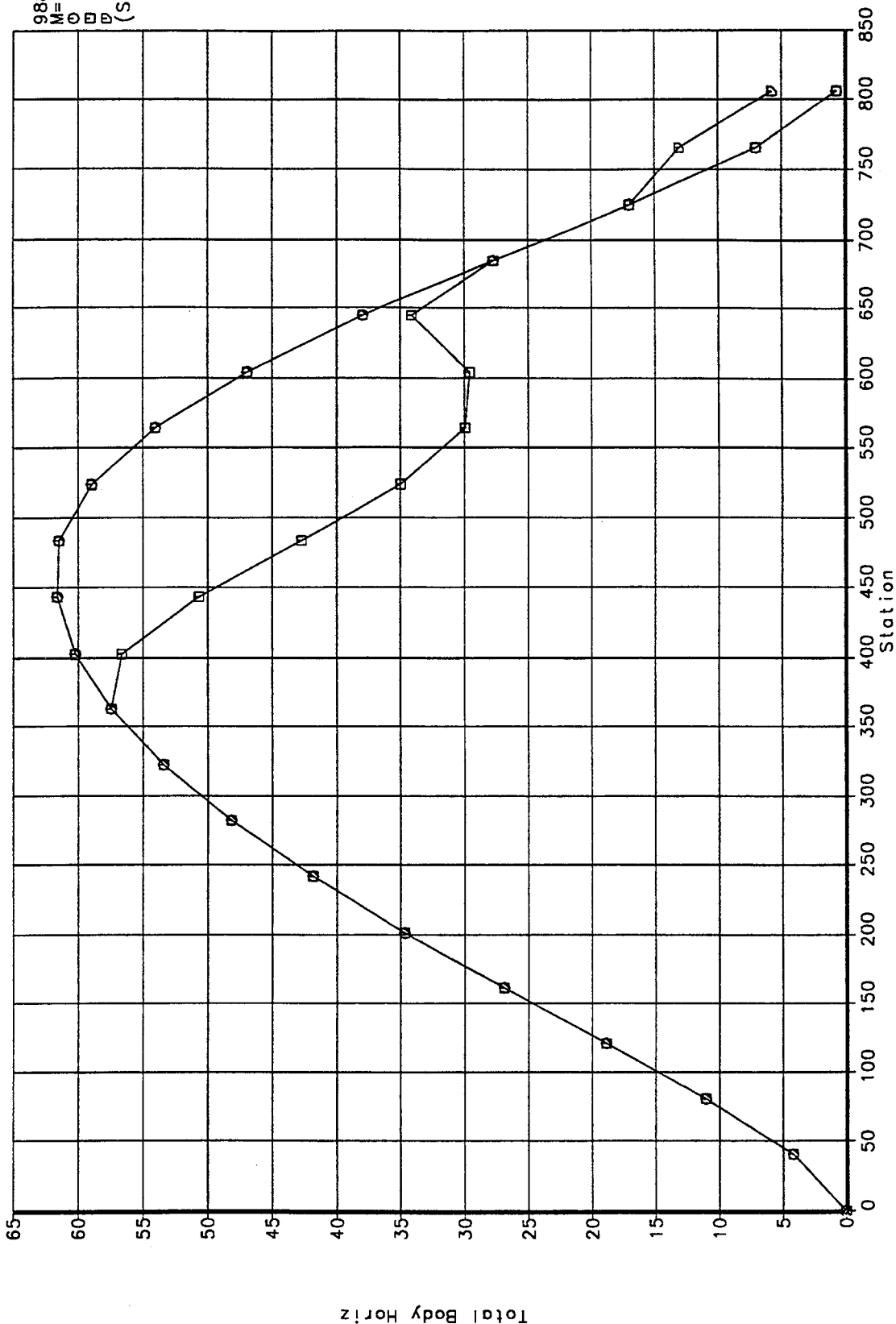

Sat Jul 16 12:51:13 1994

CALC	R.Engelbeck	7/16/94	REVISED	DATE
CHECK				
APPD.				
APPD.				

Total Body Horiz

988-115 High Agility, Moderate Observables  
 Target Cross Sectional Area Distribution

THE BOEING COMPANY

PAGE

FAST AERO DATA

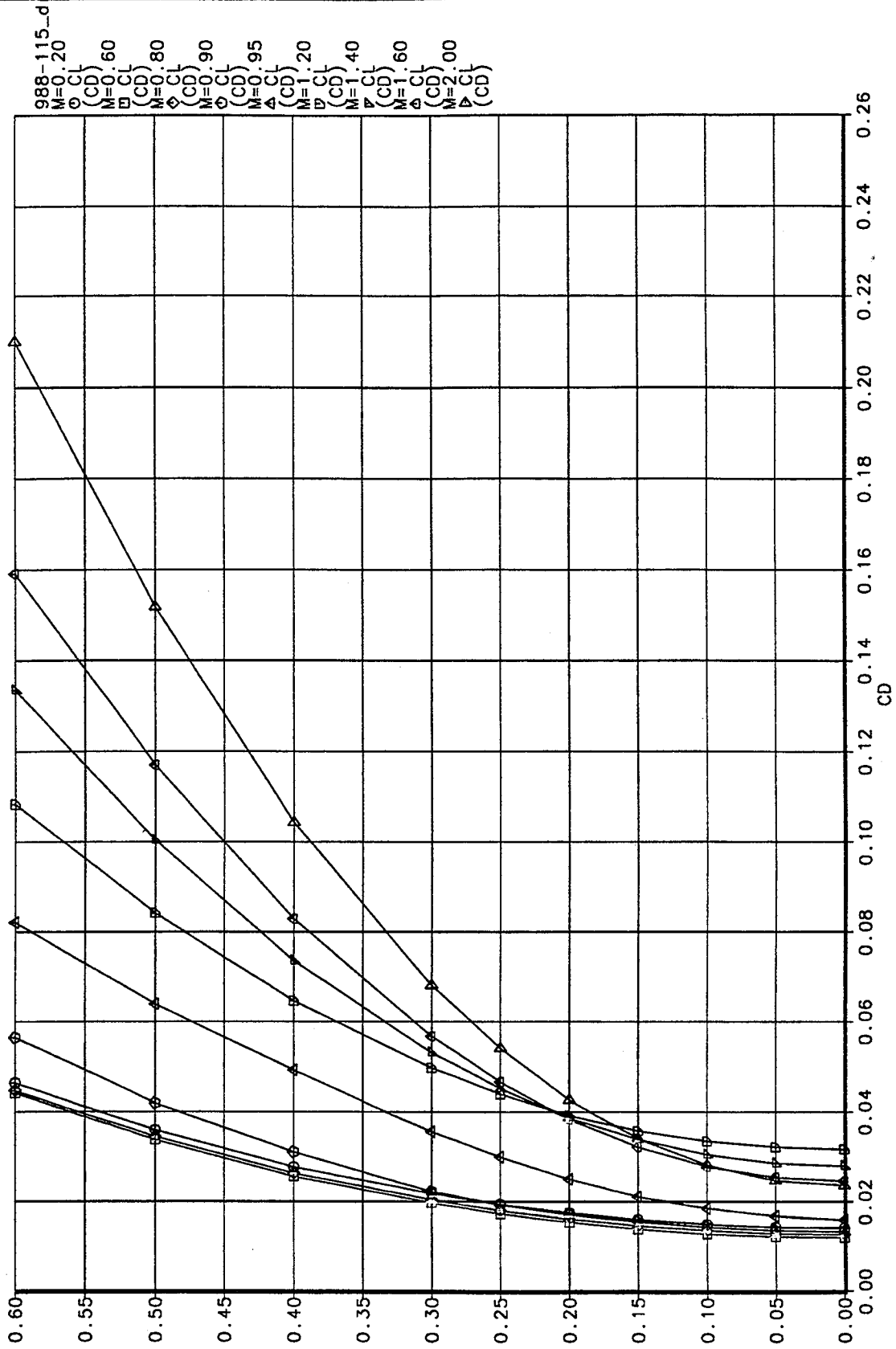

10

CALC	R.Engelbeck	7/16/94	REVISED	DATE
CHECK				
APPD.				
APPD.				

988-115 High Agility, Moderate Observables  
Target Cross Sectional Area Distribution

THE BOEING COMPANY

Design Mission Segment Performance Breakdown

Initial Weight	Final Weight	Fuel Burned	Time (min.)	Range (n.mi.)	Mach	Altitude (feet)	CL	CD	Power Setting	Net Thrust	Fuel Flow	Error Code
Warm-up and taxi												
58845.	58150.	695.1	20.00	0.0	0.000	0.	0.257	0.0168	0.040	1713.	2085.	0
Warm-up and taxi												
58150.	53698.	4452.3	2.00	0.0	0.300	0.	0.257	0.0168	2.000	70292.	133570.	0
Acceleration from Mach 0.300 to Mach 0.900												
53698.	53023.	675.0	0.27	1.8	0.900	0.	0.047	0.0114	2.000	83174.	172232.	0
Climb from 0.0 ft. to 44262.7 ft. at 100.8 ft/sec												
53023.	51821.	1201.4	3.49	27.9	0.844	44263.	0.257	0.0189	2.000	11680.	11348.	0
Cruise at Mach 0.845												
51821.	49543.	2278.4	39.72	320.3	0.845	44994.	0.323	0.0226	0.387	3538.	3407.	0
Loiter at 40000. ft and max L/D of 13.89												
49543.	44605.	4937.6	90.00	687.7	0.800	40000.	0.263	0.0190	0.305	3387.	3248.	0
Acceleration from Mach 0.800 to Mach 1.500												
44605.	43788.	817.2	0.88	9.6	1.500	40000.	0.073	0.0284	2.000	36153.	70381.	0
Cruise at Mach 1.500												
43788.	41638.	2149.6	6.31	90.4	1.500	40000.	0.068	0.0276	0.961	17345.	20426.	0
One Combat Turn at 8.2 deg/sec and 4.0 g's												
42318.	41105.	533.3	0.73	6.3	0.900	40000.	0.739	0.1000	2.000	22658.	43870.	0
One Combat Turn at 8.3 deg/sec and 4.1 g's												
41785.	40579.	526.0	0.72	6.2	0.900	40000.	0.739	0.1000	2.000	22658.	43870.	0
One Combat Turn at 8.5 deg/sec and 4.1 g's												
41009.	40060.	518.9	0.71	6.1	0.900	40000.	0.739	0.1000	2.000	22658.	43870.	0
One Combat Turn at 8.6 deg/sec and 4.2 g's												
40131.	39548.	511.8	0.70	6.0	0.900	40000.	0.739	0.1000	2.000	22658.	43870.	0
Climb from 40000.0 ft. to 49739.0 ft. at 78.4 ft/sec												
39548.	39310.	238.1	1.64	12.9	0.829	49739.	0.310	0.0222	2.000	7554.	7394.	0
Cruise at Mach 0.820												
39310.	36869.	2441.2	55.51	437.1	0.820	49815.	0.325	0.0230	0.378	2695.	2592.	0
Loiter at 0. ft and max L/D of 15.34												
36869.	35858.	1011.5	20.00	67.8	0.307	0.	0.257	0.0168	0.055	2370.	3020.	0
Total Mission Fuel = 22987. lbs Reserve Fuel = 1149. lbs												

					<-----Inital----->		<-----Final----->				
	WEIGHT	%Fuel	Payload	DeltaF	Pset	Mach	Altitude	Mach	Altitude	Require	Actual
26	48510.23	0.60	1120.00	0.00	2.00	0.60	15000.00	0.00	0.00	-100.00	-53.41
xNegPs	47698.18	0.60	1120.00	0.00	2.00	0.90	40000.00	1.50	40000.00	60.00	51.60
CCEL	48510.23	0.60	1120.00	0.00	2.00	0.60	50000.00	0.00	0.00	500.00	6639.37
axRC	55267.35	0.00	1120.00	0.00	2.00	0.60	50000.00	0.00	0.00	500.00	21080.20
WFuel	48510.23	0.60	1120.00	0.00	2.00	0.90	20000.00	0.00	0.00	9.00	9.00
LOAD2	48510.23	0.60	1120.00	0.00	2.00	0.90	30000.00	0.00	0.00	9.00	9.00
LOAD3	48510.23	0.60	1120.00	0.00	2.00	1.20	30000.00	0.00	0.00	9.00	9.00
LOAD4	48510.23	0.60	1120.00	0.00	2.00	0.60	10000.00	0.00	0.00	6.00	6.40
LOAD1	48510.23	0.60	1120.00	0.00	2.00	0.90	10000.00	0.00	0.00	9.00	9.00
LOAD2	48510.23	0.60	1120.00	0.00	2.00	0.60	20000.00	0.00	0.00	4.40	4.40
LOAD3	48510.23	0.60	1120.00	0.00	2.00	0.90	20000.00	0.00	0.00	7.00	8.32
LOAD4	48510.23	0.60	1120.00	0.00	2.00	1.20	20000.00	0.00	0.00	6.80	7.90
LOAD5	48510.23	0.60	1120.00	0.00	2.00	0.90	30000.00	0.00	0.00	5.00	5.49
LOAD6	48510.23	0.60	1120.00	0.00	2.00	1.20	30000.00	0.00	0.00	5.00	5.83
LOAD7	48510.23	0.60	1120.00	0.00	2.00	0.60	0.00	0.00	0.00	900.00	968.22
S1	48510.23	0.60	1120.00	0.00	2.00	0.90	0.00	0.00	0.00	1300.00	1442.85
S2	48510.23	0.60	1120.00	0.00	2.00	0.60	10000.00	0.00	0.00	650.00	716.27
S3	48510.23	0.60	1120.00	0.00	2.00	0.90	10000.00	0.00	0.00	1000.00	1143.51
S4	55267.35	0.60	1120.00	0.00	2.00	1.20	10000.00	0.00	0.00	600.00	998.04
S5	48510.23	0.60	1120.00	0.00	2.00	0.60	20000.00	0.00	0.00	450.00	484.50
S6	48510.23	0.60	1120.00	0.00	2.00	0.90	20000.00	0.00	0.00	800.00	840.16
S7	48510.23	0.60	1120.00	0.00	2.00	1.20	20000.00	0.00	0.00	650.00	781.47
S8	48510.23	0.60	1120.00	0.00	2.00	1.40	20000.00	0.00	0.00	600.00	811.69
S9	48510.23	0.60	1120.00	0.00	2.00	0.90	30000.00	0.00	0.00	550.00	554.71
S10	48510.23	0.60	1120.00	0.00	2.00	1.20	30000.00	0.00	0.00	500.00	628.82
S11	48510.23	0.60	1120.00	0.00	2.00	1.40	30000.00	0.00	0.00	600.00	752.68
S12	48510.23	0.60	1120.00	0.00	2.00	1.40	30000.00	0.00	0.00	600.00	752.68

### Model 988-114, Medium Agility - Low Observables

The medium agility, low observables vehicle, Model 988-114, is a single place tail-less supersonic design powered by two afterburning low-bypass turbofans of 36200 pounds (augmented) thrust each. It is capable of Mach 1.5 on un-augmented engine thrust. Low observable characteristics include low sideslope angles, long planform outline edges, edge alignment, lack of any vertical tail surfaces, and inlets integrated into the wing-body junction.

The wing planform was chosen to allow some forward sweep on the trailing edge while maintaining the desired (reference) aspect ratio of 4. The tip was "beveled" to alleviate undesirable aerodynamic, structural and RCS effects.

Inlets are canted F-22 type, with angles chosen to integrate with the leading edge while meeting side slope and inlet ramp angle requirements. Placement at the wing-body junction results in the intake duct passing alongside rather than over the weapons bay. Yaw vectoring exhaust nozzles are located on the upper aft fuselage; their fairing widths determine the thrust centerline spacing.

Control effectors include those on the trailing edge of the wing, the yaw vectoring nozzles, "yaw vanes" forming the forward part of the nozzle fairings (and on the underside of the aft fuselage), and aft body flaps to provide thrust vectoring in pitch. There are large leading edge slats to enhance maneuvering. The mid-outboard elevons are split to act as drag rudders.

The interior layout, as shown by the Inboard Profile (ASC988-114-2) is conventional for tactical aircraft, with the exception of the internal weapons bay (side-by-side missiles) and exhaust nozzle arrangement. Most the fuel is contained in the large integral wing tanks, with a smaller, protected tank above the weapons bay for balance.

The exhaust system includes full augmentation, and a rotating nozzle with variable throat and exit plane areas; an alternate aft body integration scheme is shown (versus 988-115 or -118). In the cruise position, the aft body flaps provide a "SERN" expansion surface; at any substantial vector angle, the nozzle must act as a 2D-CD nozzle. Achieving acceptable efficiencies and effective vectoring is a significant technical risk (see Section 7.0).

# FOLDOUT FRAME

FO

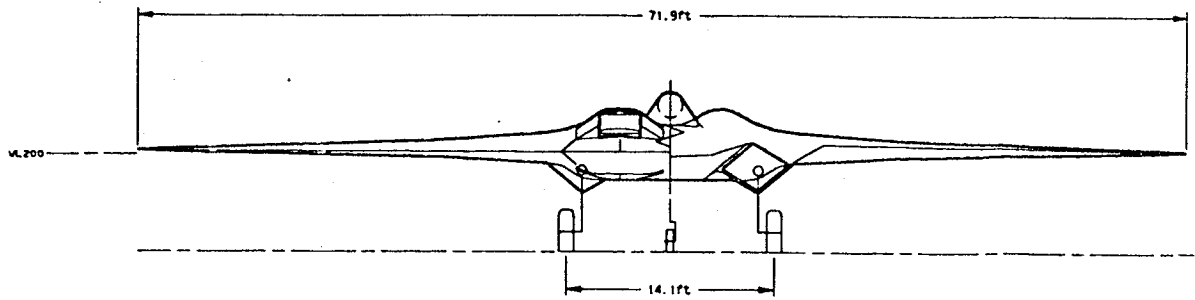

ORIGINAL PAGE IS  
OF POOR QUALITY

ALL RIGHTS RESERVED TO THE ROSS COMPANY  
REPRODUCED IN WHOLE OR IN PART OR  
BY ANY USER POSSESSOR DIRECT WRITTEN  
PERMISSION.

DATE	NO.	REV.
11/25		





BEING PROPRIETARY  
 THE INFORMATION CONTAINED HEREIN IS PROPRIETARY TO THE BOEING COMPANY  
 AND SHALL NOT BE REPRODUCED OR DISCLOSED IN WHOLE OR IN PART OR  
 USED FOR ANY PURPOSE EXCEPT WHEN SUCH USER POSSESSES DIRECT WRITTEN  
 AUTHORIZATION FROM THE BOEING COMPANY.

2  
 OLDOUT FRAME

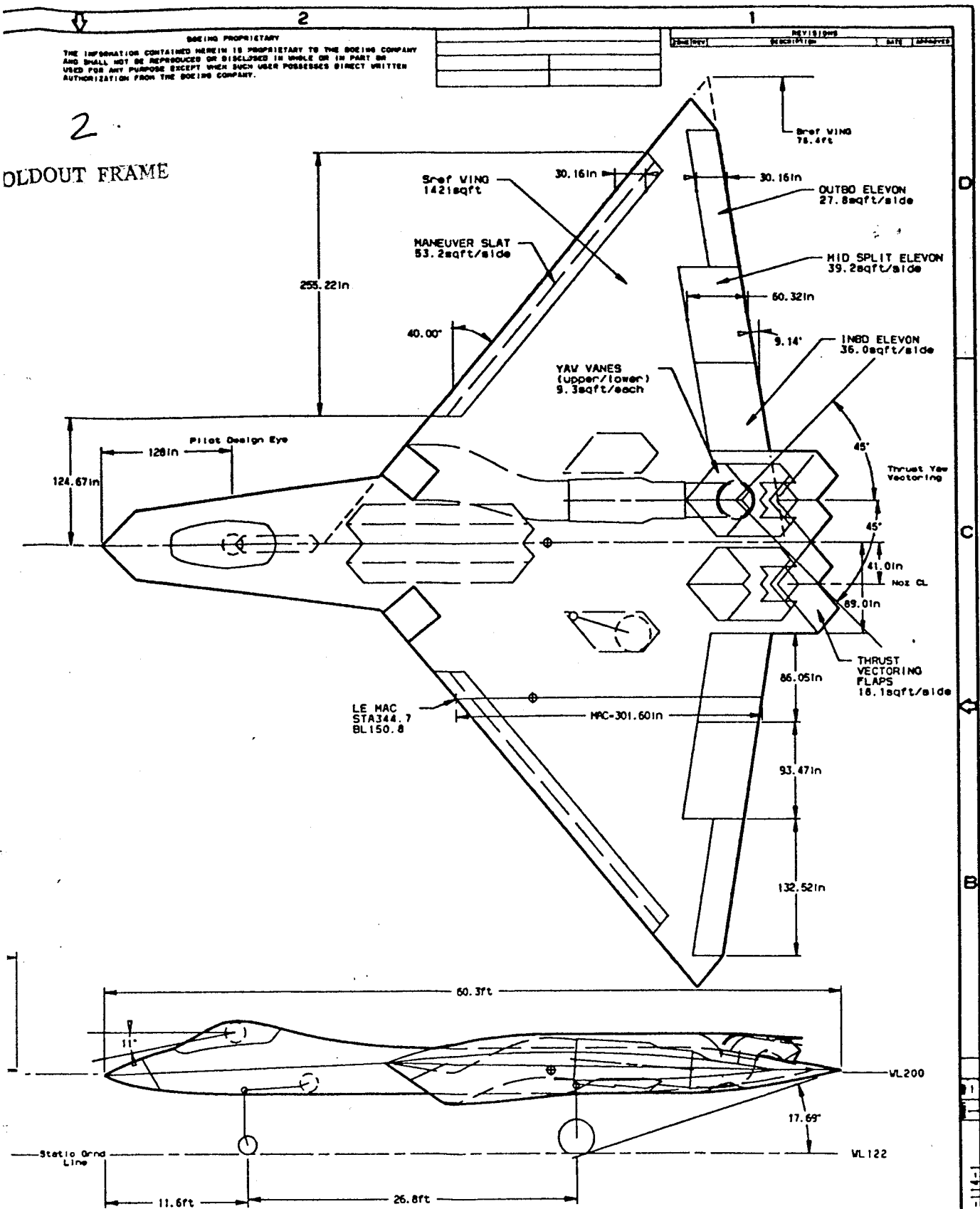

VEHICLE TYPE  
 \*MEDIUM AGILITY  
 \*LOW OBSERVABLES

ORIGINAL PAGE IS  
 OF POOR QUALITY

DATE	BY	CHKD	AS/11/CM	<b>BOEING</b> CORPORATE OFFICES SEATTLE, WA 98124
MODEL	DESIGNED	BY	DATE	
SECY NO.	X	BY	DATE	GENERAL ARRANGEMENT
CONF NO.	X	BY	DATE	MODEL 988-114
GROUP	X	BY	DATE	AIR SUPERIORITY CONFIG
CONF	X	BY	DATE	STY CASE CODE/REV NO.
CONF	X	BY	DATE	J 01205 ASC 988-114-1
CONF	X	BY	DATE	SCALE 1/40 PINX

EX1

ASC 988-114-1

DRAWING RECORD



OUT FRAME

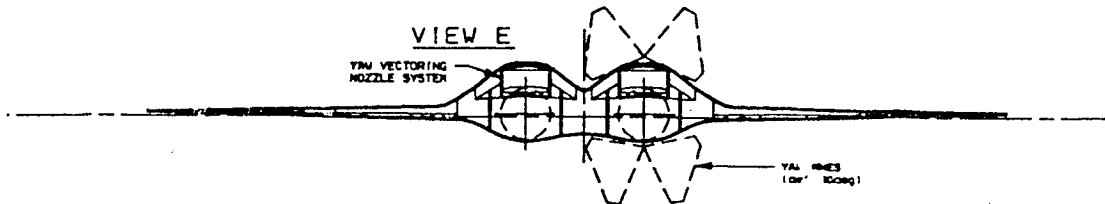
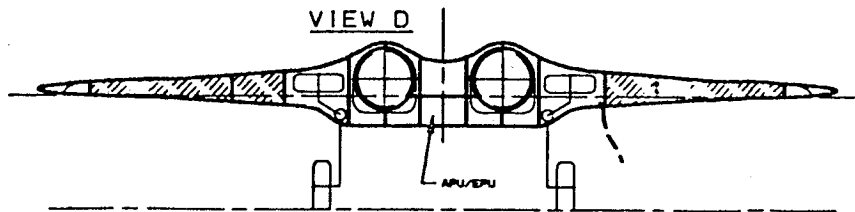
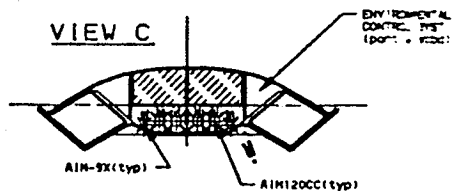
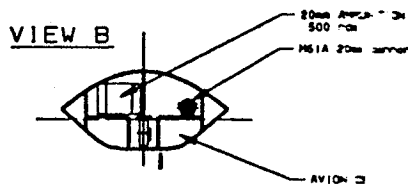
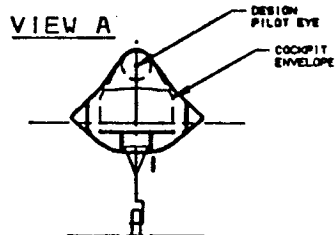

JRPAMY

FORM NO.	REV.	DATE
61205		





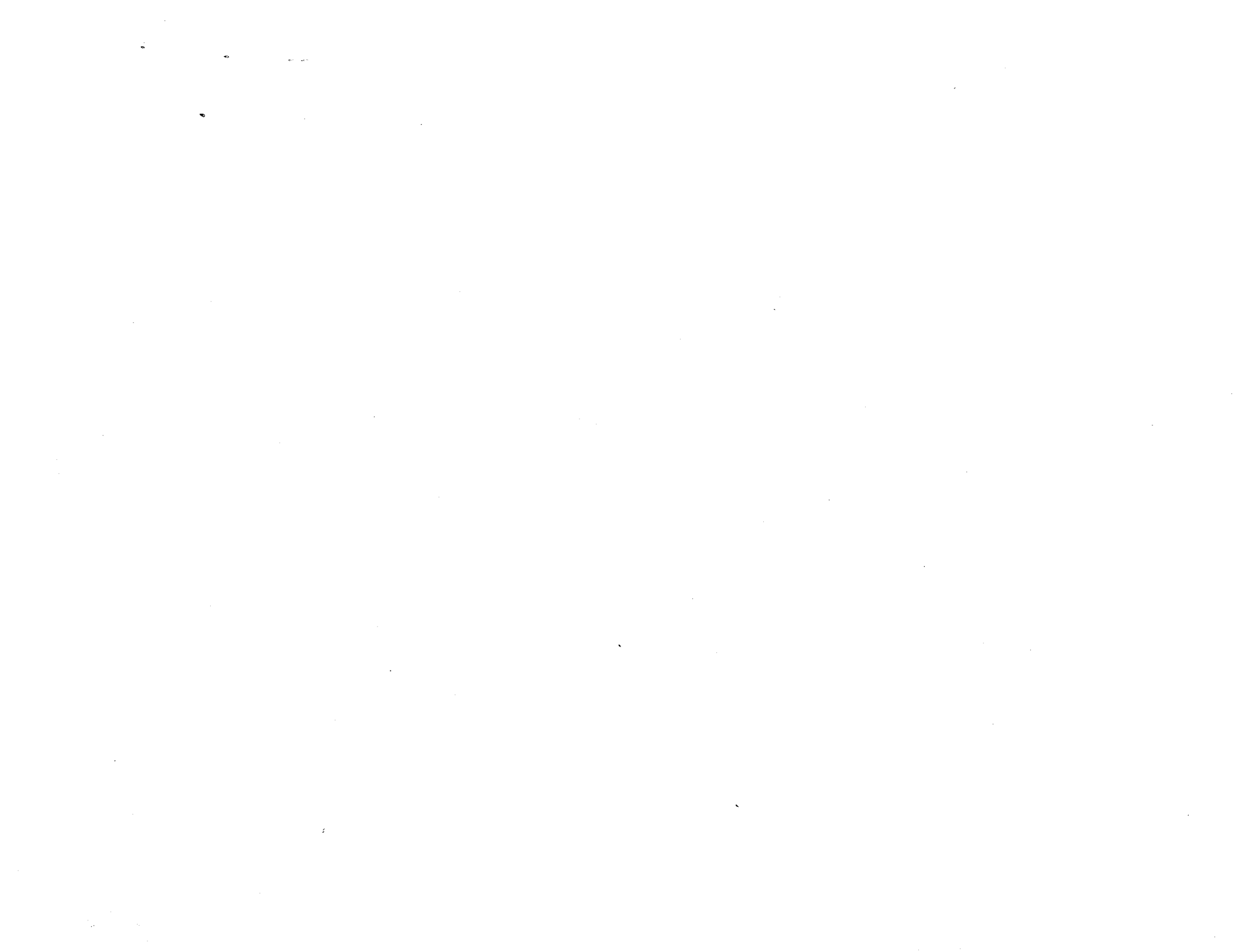

<b>GROUP WEIGHT STATEMENT</b>			
MISSION: Air-to-Air	WEIGHT (LB)	NOSE STATION	0 IN
MODEL: 988-114 MedA/LO		WING MAC	303 IN
		LEMAC	344 IN
		BODY LENGTH	725 IN
		BODY STATION	PERCENT MAC
WING	9275	490	
BODY	9057	419	
MAIN GEAR	1382	461	
NOSE GEAR	313	140	
AIR INDUCTION	787	360	
ENGINE SECTION	335	509	
YAW VANES	374	604	
<b>TOTAL STRUCTURE</b>	<b>21523</b>	<b>451</b>	
ENGINES	3934	509	
AMADS	200	434	
ENGINE CONTROLS	40	320	
STARTING SYSTEM	80	464	
FUEL SYSTEM	1103	444	
VECTORING NOZZLES	1631	626	
<b>TOTAL PROPULSION</b>	<b>6988</b>	<b>522</b>	
FLIGHT CONTROLS	1347	543	
APU	210	580	
INSTRUMENTS	270	135	
HYDRAULICS	457	485	
ELECTRICAL	690	369	
AVIONICS	1569	152	
ARMAMENT	242	210	
FURNISHINGS & EQUIPMENT	371	219	
AIR CONDITIONING	712	300	
ANTI-ICE	10	90	
LOAD & HANDLING	10	419	
<b>TOTAL FIXED EQUIPMENT</b>	<b>5888</b>	<b>332</b>	
<b>WEIGHT EMPTY</b>	<b>34399</b>	<b>445</b>	<b>33.3%</b>
CREW	215	130	
CREW EQUIPMENT	40	130	
OIL & TRAPPED OIL	100	474	
TRAPPED FUEL	405	444	
GUN INSTALLATION	252	210	
LAUNCHERS/EJECTORS	760	340	
AMMO CASES	113	210	
<b>NON-EXP USEFUL LOAD</b>	<b>1885</b>	<b>316</b>	
<b>OPERATING WEIGHT</b>	<b>36284</b>	<b>438</b>	<b>31.1%</b>
BOMBS/MISSILES	1800	337	
AMMO EXPENDABLE	137	210	
FUEL	27009	444	
<b>GROSS WEIGHT</b>	<b>65230</b>	<b>437</b>	<b>30.6%</b>



Nose @ BS 0  
 LEMAC @ BS 344  
 MAC Length = 303 In.  
 AC @ 30.4% MAC

**C.G. MOVEMENT RELATIONSHIP  
 TO AIRCRAFT WEIGHT**

Model 988-114 MedA/LO

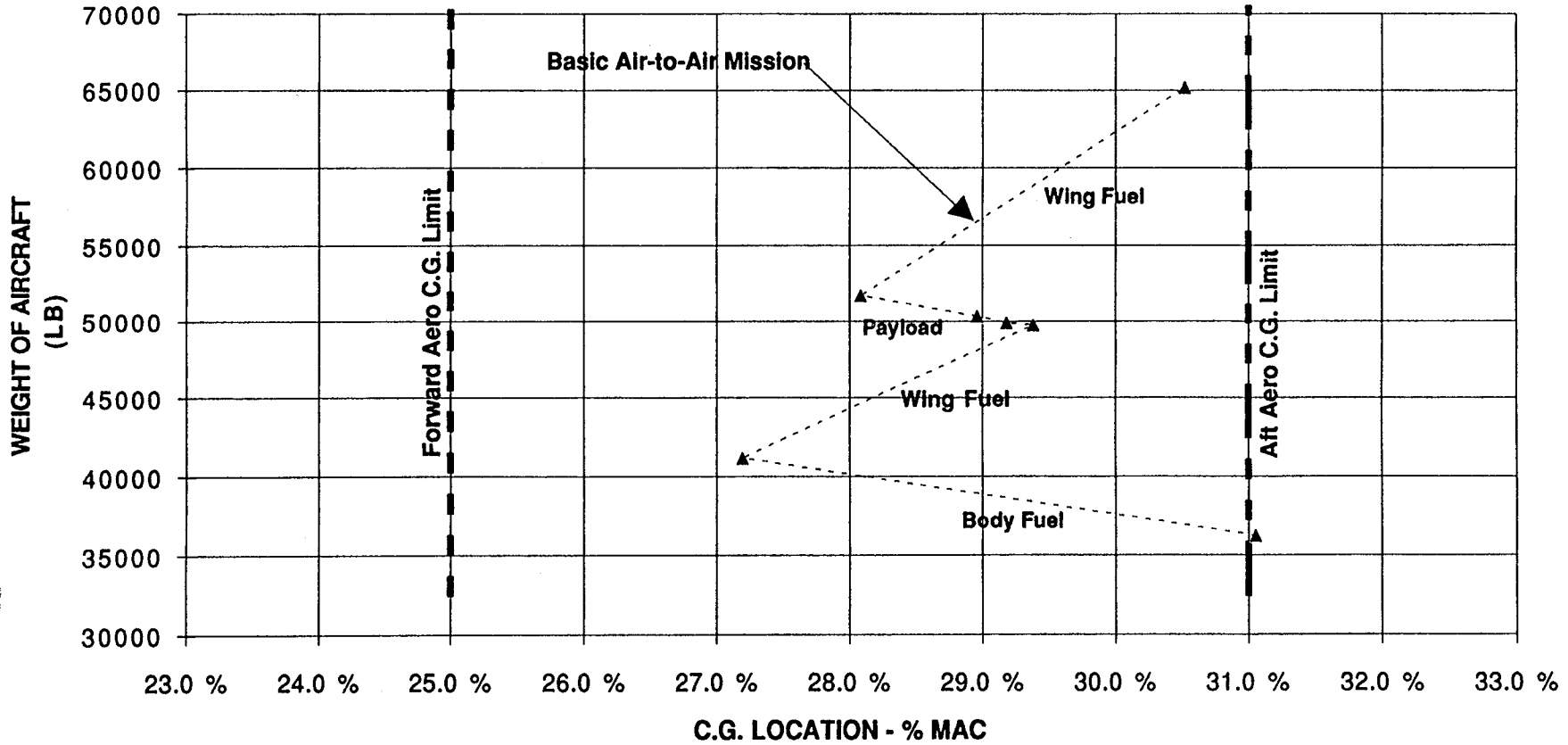

ORIGINAL PAGE IS  
 OF POOR QUALITY

### Inertia Data at Combat Weight

		A/A Model
Parameter	Units	988-114
		Med A/LO
Combat Weight	lbs	51730
Longitudinal C.G. (Body Sta)	in.	429
Vertical C.C. (from static ground line)	in.	79
Ixx Roll Inertia	slug-ft <sup>2</sup>	123597
Iyy Pitch Inertia	slug-ft <sup>2</sup>	195819
Izz Yaw Inertia	slug-ft <sup>2</sup>	352451
Ixz Product of Inertia	slug-ft <sup>2</sup>	2002

## Aircraft Geometry

Thrust-to-Weight	=	1.13	Wing-Loading	=	44.3
Takeoff Gross Weight	=	63309.6	Reference Area	=	1429.1
Wetted Area	=	3623.7	Swet/Sref	=	2.54

## Body Geometry

Fineness Ratio	=	8.80	Width	=	11.83
Length	=	60.30	Volume	=	1222.1
Wetted Area	=	1347.0			

## Wing Geometry

Area	=	1429.1	Wetted Area	=	1998.3
Aspect Ratio	=	3.64	Taper Ratio	=	0.00
Span	=	72.12	Mean Aero Chord	=	26.42
Mean t/c	=	0.05			

## Sweep Angles

Leading Edge	=	47.70
Quarter Chord	=	39.50
Trailing Edge	=	0.01

NOTE: ARPITCH= 6.73, ARWE= 3.64 Wing STABLE in Pitch at High Angles-of-Attack

## Vertical Tail Geometry (each)

Number of Vertical Tails	=	2.	Wetted Area	=	139.2
Area	=	69.6	Taper Ratio	=	0.10
Aspect Ratio	=	1.70	Mean Aero Chord	=	7.82
Span	=	10.87			
Mean t/c	=	0.05			

## Sweep Angles

Leading Edge	=	40.00
Quarter Chord	=	30.90
Trailing Edge	=	-7.04

## Engine Geometry

Engine Scale	=	0.9028	Capture Reference Area	=	7.54
Engine Diameter	=	33.37	Nozzle Base Drag Reference Area	=	60.76
Sea-Level Static Thrust	=	35769.9			
Engine Weight	=	3096.6			

Weight Statement	Weight (LBS)	Weight Fraction	Volume (cu ft)	CG (ft)	Moment (ft/lb)
<b>Airframe Structure</b>					
Fuselage.....	8941.	0.1412	89.	35.27	315304.
Wing.....	8595.	0.1358	86.	46.26	397608.
Canard.....	0.	0.0000	0.	0.00	0.
Horizontal Tail.....	0.	0.0000	0.	0.00	0.
Vertical Tail(s).....	375.	0.0059	4.	0.00	0.
Engine Mounts.....	324.	0.0051	3.	55.68	18056.
Inlet(s) and Duct(s).....	1265.	0.0200	85.	53.41	67587.
Exhaust Duct(s).....	0.	0.0000	8.	0.00	0.
Pivots.....	0.	0.0000	0.	0.00	0.
Main Landing Gear.....	1356.	0.0214	53.	36.47	49450.
Nose Gear.....	333.	0.0053	16.	22.45	7470.
Total	21189.	0.3347	344.	40.37	855475.
<b>Propulsion System</b>					
Engine(s) and Nozzle(s).....	6193.	0.0978	4.	55.68	344829.
Engine Start and Control.....	120.	0.0019	2.	33.47	2008.
Fuel Tanks.....	291.	0.0046	33.	34.37	10013.
Fuel Pumps.....	97.	0.0015	2.	34.37	3323.
Fuel Distribution System.....	547.	0.0086	14.	34.37	18815.
Air-Refueling System.....	75.	0.0012	2.	34.37	2578.
Fuel Inerting System.....	77.	0.0012	2.	34.37	2641.
Gear Box and Accessories.....	200.	0.0032	5.	55.68	11137.
Total	7600.	0.1200	64.	52.02	395344.
<b>Fixed Equipment</b>					
Instruments.....	270.	0.0043	7.	25.80	6966.
Surface Controls.....	1157.	0.0183	29.	35.60	41182.
Crew Accomodations.....	371.	0.0059	70.	21.06	7813.
Armaments.....	1012.	0.0160	34.	34.37	34783.
Avionics.....	1569.	0.0248	30.	24.12	37838.
Electrical System.....	622.	0.0098	16.	20.55	12779.
Hydraulics and Pneumatics.....	423.	0.0067	11.	31.96	13514.
Radar Absorpton Material.....	0.	0.0000	0.	0.00	0.
Auxiliary Power System.....	210.	0.0033	7.	0.00	0.
Airconditioning and De-Icing....	628.	0.0099	31.	11.18	7020.
Total	6261.	0.0989	234.	25.86	161896.
Empty Weight.....	35050.	0.5536	0.	40.31	*****
<b>Operational Items</b>					
Crew.....	255.	0.0040	4.	11.25	2869.
Trapped Fuel and Oil.....	475.	0.0075	9.	45.03	21378.
Gun and Provisions.....	365.	0.0058	7.	0.00	0.
Operational Empty Weight.....	36145.	0.5709	0.	0.00	0.
<b>Payload</b>					
Ammunition.....	137.	0.0022	5.	0.00	0.
Air-to-Air Missles.....	1800.	0.0284	95.	0.00	0.
Air-to-Ground Munitions.....	0.	0.0000	240.	34.37	0.
Total	1937.	0.0306	340.	0.00	0.
<b>Mission Fuel</b>					
Wing Fuel.....	24138.	0.3813	496.	0.00	0.
Body Fuel.....	1089.	0.0172	22.	0.00	0.
External Fuel.....	0.	0.0000	0.		
Design Gross Weight.....	63310.	1.0000	1793.	34.37	*****

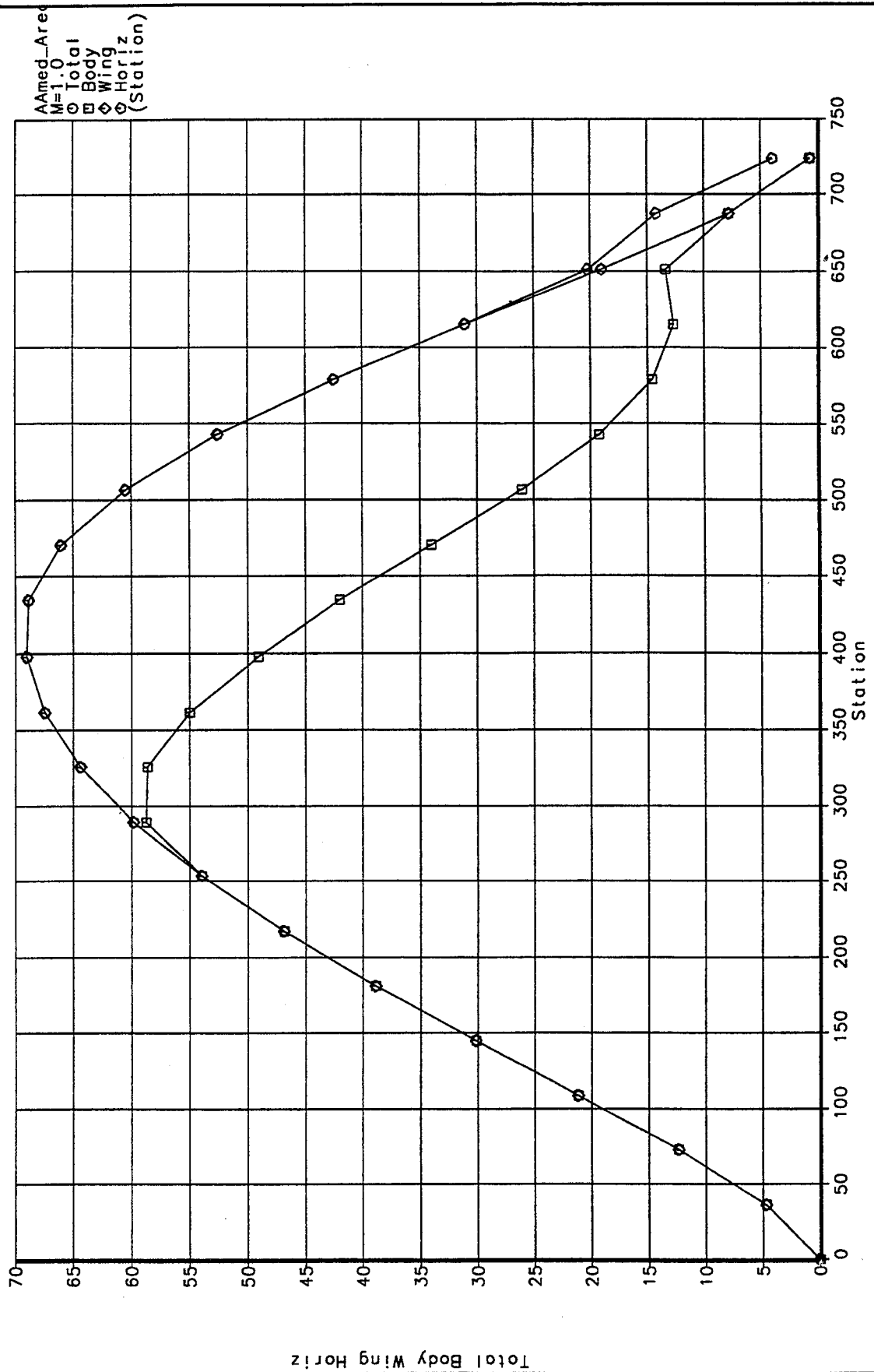

Total Body Wing Horiz					988-114 Med. Agility, Low Observables Target Cross Sectional Area Distribution	
CALC	R.Engelbeck	7/16/94	REVISED	DATE		
CHECK						
APPD.						
APPD.						
					THE BOEING COMPANY	PAGE 134

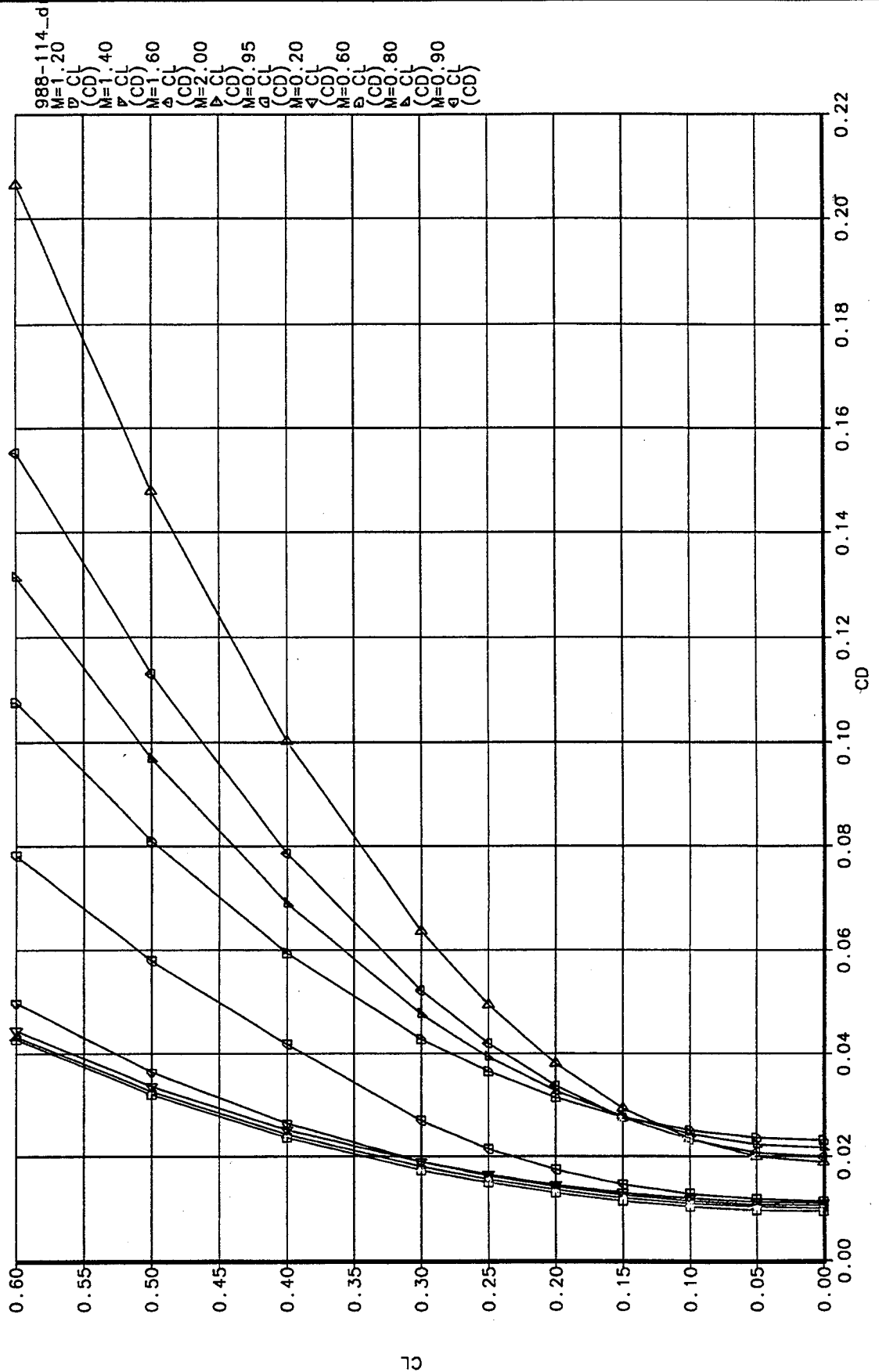

Sat Jul 16 12:13:39 1994

CALC	R.Engelbeck	7/16/94	REVISED	DATE	988-114 Med Agility, Low Observables Cruise Drag Polar	
CHECK						
APPD.						
APPD.						
					THE BOEING COMPANY	PAGE 135

Design Mission Segment Performance Breakdown

Initial Weight	Final Weight	Fuel Burned	Time (min.)	Range (n.mi.)	Mach	Altitude (feet)	CL	CD	Power Setting	Net Thrust	Fuel Flow	Error Code
Warm-up and taxi												
63310.	62558.	751.2	20.00	0.0	0.000	0.	0.222	0.0132	0.040	1851.	2254.	0
Warm-up and taxi												
62558.	57747.	4811.4	2.00	0.0	0.300	0.	0.222	0.0132	2.000	75961.	144342.	0
Acceleration from Mach 0.300 to Mach 0.900												
57747.	57020.	727.3	0.27	1.7	0.900	0.	0.036	0.0091	2.000	89882.	186123.	0
Climb from 0.0 ft. to 49699.4 ft. at 81.0 ft/sec												
57020.	55515.	1504.2	4.63	38.9	0.885	49699.	0.224	0.0155	2.000	10507.	10422.	0
Cruise at Mach 0.876												
55515.	53359.	2156.4	36.78	309.3	0.876	49698.	0.287	0.0187	0.435	3543.	3457.	0
Loiter at 40000. ft and max L/D of 14.39												
53359.	48190.	5168.6	90.00	687.7	0.800	40000.	0.202	0.0140	0.294	3527.	3410.	0
Acceleration from Mach 0.800 to Mach 1.500												
48190.	47330.	860.4	0.86	9.4	1.500	40000.	0.056	0.0225	2.000	39069.	76057.	0
Cruise at Mach 1.500												
47330.	44899.	2430.8	6.32	90.6	1.500	40000.	0.052	0.0221	1.003	19559.	23025.	0
One Combat Turn at 10.2 deg/sec and 4.9 g's												
45579.	44434.	465.0	0.59	5.1	0.900	40000.	0.694	0.0768	2.000	24486.	47409.	0
One Combat Turn at 10.3 deg/sec and 5.0 g's												
45114.	43974.	460.0	0.58	5.0	0.900	40000.	0.694	0.0768	2.000	24486.	47409.	0
One Combat Turn at 10.4 deg/sec and 5.0 g's												
44404.	43519.	455.0	0.58	5.0	0.900	40000.	0.694	0.0768	2.000	24486.	47409.	0
One Combat Turn at 10.5 deg/sec and 5.1 g's												
43590.	43069.	450.1	0.57	4.9	0.900	40000.	0.694	0.0768	2.000	24486.	47409.	0
Climb from 40000.0 ft. to 49981.7 ft. at 75.0 ft/sec												
43069.	42805.	263.9	1.76	13.3	0.799	49982.	0.261	0.0171	2.000	7858.	7609.	0
Cruise at Mach 0.780												
42805.	40313.	2492.2	57.91	436.7	0.780	49689.	0.276	0.0177	0.356	2668.	2527.	0
Loiter at 0. ft and max L/D of 16.79												
40313.	39281.	1032.2	20.00	64.4	0.291	0.	0.222	0.0132	0.051	2370.	3083.	0
Total Mission Fuel = 24029. lbs Reserve Fuel = 1201. lbs												

136

26	WEIGHT	%Fuel	Payload	DeltaF	Pset	<-----Inital----->		<-----Final----->		Require	Actual
						Mach	Altitude	Mach	Altitude		
MxNegPs	52540.09	0.60	1120.00	0.00	2.00	0.60	15000.00	0.00	0.00	-450.00	322.02
ACCEL	51691.42	0.60	1120.00	0.00	2.00	0.90	40000.00	1.50	40000.00	60.00	49.80
MaxRC	52540.09	0.60	1120.00	0.00	2.00	0.60	50000.00	0.00	0.00	500.00	6605.78
dWFuel	55267.35	0.00	1120.00	0.00	2.00	0.60	50000.00	0.00	0.00	500.00	23868.53
ILOAD2	52540.09	0.60	1120.00	0.00	2.00	0.90	20000.00	0.00	0.00	9.00	9.00
ILOAD3	52540.09	0.60	1120.00	0.00	2.00	0.90	30000.00	0.00	0.00	9.00	9.00
ILOAD4	52540.09	0.60	1120.00	0.00	2.00	1.20	30000.00	0.00	0.00	9.00	9.00
SLOAD1	52540.09	0.60	1120.00	0.00	2.00	0.60	10000.00	0.00	0.00	6.00	7.70
SLOAD2	52540.09	0.60	1120.00	0.00	2.00	0.90	10000.00	0.00	0.00	9.00	9.00
SLOAD3	52540.09	0.60	1120.00	0.00	2.00	0.60	20000.00	0.00	0.00	4.40	5.21
SLOAD4	52540.09	0.60	1120.00	0.00	2.00	0.90	20000.00	0.00	0.00	7.00	9.00
SLOAD5	52540.09	0.60	1120.00	0.00	2.00	1.20	20000.00	0.00	0.00	6.80	8.84
SLOAD6	52540.09	0.60	1120.00	0.00	2.00	0.90	30000.00	0.00	0.00	5.00	6.70
SLOAD7	52540.09	0.60	1120.00	0.00	2.00	1.20	30000.00	0.00	0.00	5.00	6.49
PS1	52540.09	0.60	1120.00	0.00	2.00	0.60	0.00	0.00	0.00	900.00	964.28
PS2	52540.09	0.60	1120.00	0.00	2.00	0.90	0.00	0.00	0.00	1300.00	1430.59
PS3	52540.09	0.60	1120.00	0.00	2.00	0.60	10000.00	0.00	0.00	650.00	714.23
PS4	52540.09	0.60	1120.00	0.00	2.00	0.90	10000.00	0.00	0.00	1000.00	1135.82
PS4	55267.35	0.60	1120.00	0.00	2.00	1.20	10000.00	0.00	0.00	600.00	998.04
PS6	52540.09	0.60	1120.00	0.00	2.00	0.60	20000.00	0.00	0.00	450.00	484.25
PS7	52540.09	0.60	1120.00	0.00	2.00	0.90	20000.00	0.00	0.00	800.00	836.14
PS8	52540.09	0.60	1120.00	0.00	2.00	1.20	20000.00	0.00	0.00	650.00	818.98
PS9	52540.09	0.60	1120.00	0.00	2.00	1.40	20000.00	0.00	0.00	600.00	798.68
PS10	52540.09	0.60	1120.00	0.00	2.00	0.90	30000.00	0.00	0.00	550.00	553.80
PS11	52540.09	0.60	1120.00	0.00	2.00	1.20	30000.00	0.00	0.00	500.00	653.25
PS12	52540.09	0.60	1120.00	0.00	2.00	1.40	30000.00	0.00	0.00	600.00	746.35





# FOLDOUT ERAME |

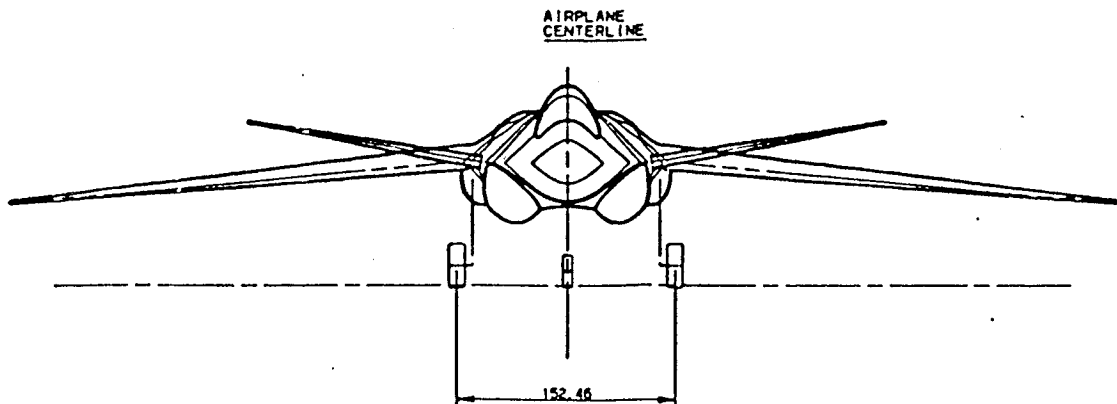

BOEING PROPRIETARY  
THE INFORMATION CONTAINED HEREIN IS PROPRIETARY TO THE BOEING COMPANY  
AND SHALL NOT BE REPRODUCED OR DISCLOSED IN WHOLE OR IN PART OR  
USED FOR ANY PURPOSE EXCEPT UNDER SUCH USER POSSESSES DIRECT WRITTEN  
AUTHORIZATION FROM THE BOEING COMPANY.



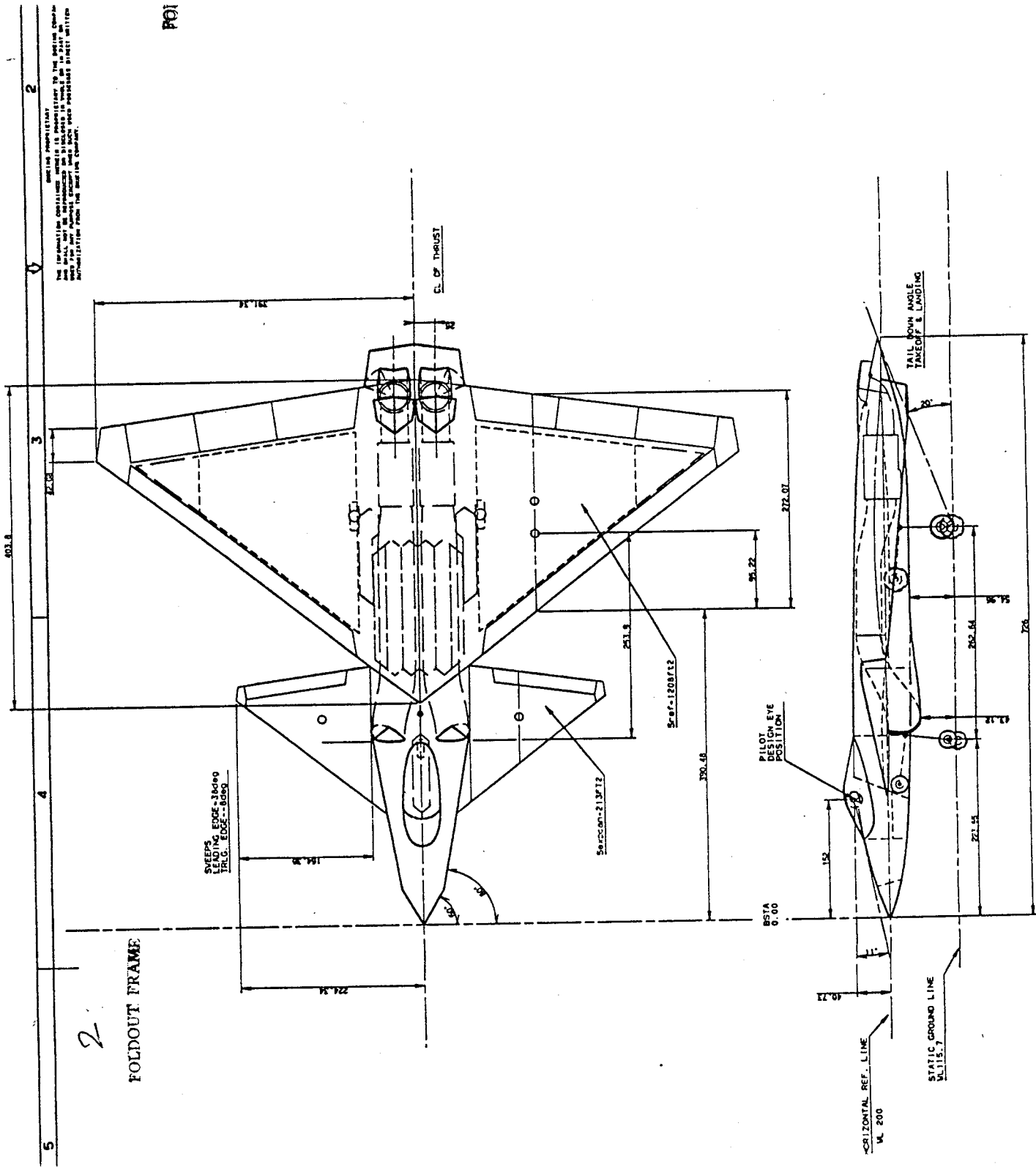

5

2

ALL DIMENSIONS PROPRIETARY  
 THE INFORMATION CONTAINED HEREIN IS UNCLASSIFIED TO THE EXTENT PERMITTED BY LAW AND IS BEING RELEASED UNDER E.O. 13526, WHICH AUTHORITY IS DERIVED FROM THE ORIGINAL SOURCE AND DOES NOT CONSTITUTE AN ENDORSEMENT OR APPROVAL BY THE ISSUING OFFICE.

FOLDOUT FRAME

FOI

2

4

3

1

2



### 6.3 Multi-Role Concepts

#### Model 988-119, High Agility, Moderate Observables

The high agility, moderate observables vehicle, Model 988-119, is a single place tail-less transonic design powered by two afterburning low-bypass turbofans of 28500 pounds (augmented) thrust each. It is capable over Mach 1.5 on augmented engine thrust. Reduced signature characteristics include moderate sideslope angles, edge alignment, lack of any vertical tail surfaces, and inlets integrated into the wing-body junction.

The modified trapezoid planform was chosen to allow a higher aspect ratio without excessively narrow tip chords. Placement of the wing on the body for proper balance required the use of a canard instead of a conventional horizontal tail.

Inlets are F-22 type, with angles chosen to align with the trailing edge while meeting side slope and inlet ramp angle requirements. Placement at the wing-body junction results in the intake duct passing alongside rather than over the weapons bay. Yaw vectoring exhaust nozzles are located in the aft fuselage.

Control effectors include those on the trailing edge of the wing, the canards, the yaw vectoring nozzles, "yaw vanes" forming the forward part of the nozzle fairings, and aft body flaps to provide thrust vectoring in pitch. There are large leading edge slats to enhance maneuvering. The mid-outboard elevons are split to act as drag rudders.

The canards require high deflection capability to allow for effectiveness in high-Alpha maneuvers. They have 10 degrees of dihedral to reduce interference with the wing and inlets.

The interior layout, as shown by the Inboard Profile (ASC988-119-2) is conventional for tactical aircraft, with the exception of the internal weapons bay (side-by-side bombs/missiles) and exhaust nozzle arrangement. The fuel is contained in integral wing tanks, and a protected tank above the weapons bay.

The exhaust system includes full augmentation, and dual rotating nozzles with variable throat and exit plane areas; this is an alternate nozzle arrangement from the single rotating nozzles shown on the other configurations. It appears to offer reduced flow-turning losses and improved aft-body integration. It also offers better pitch vectoring effectiveness (with the vectoring flap located between the nozzles), along with more flexibility for simultaneous yaw and pitch vectoring through differential pivoting of the upper and lower nozzles. There is not as much duct offset, but this is acceptable for a moderate observables aircraft. Achieving acceptable efficiencies and effective vectoring is a significant technical risk (see Section 7.0).



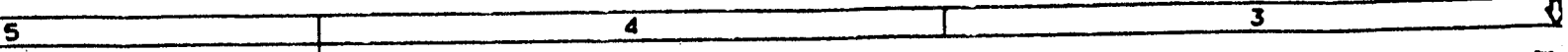

THE  
AND  
USED  
AUTH

FOLDOUT FRAME 1.

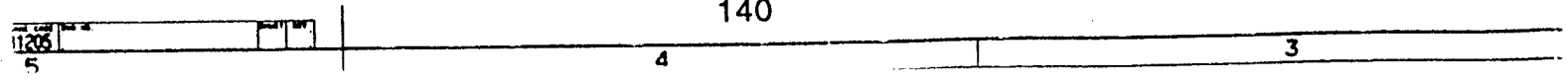
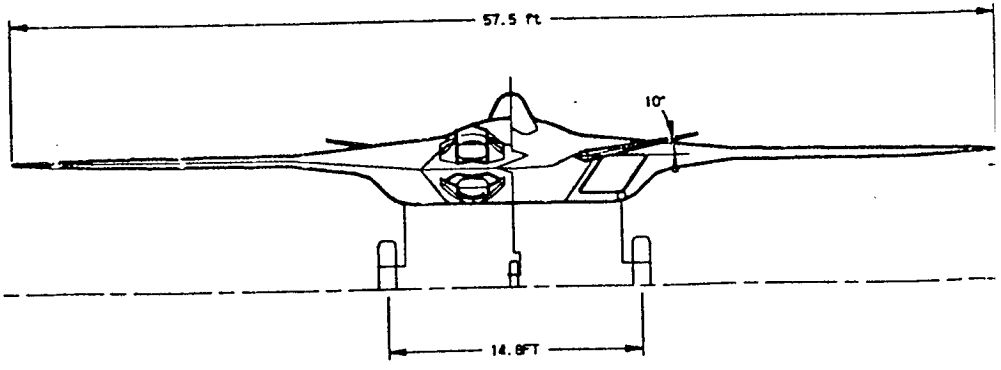









1.  
FOLDOUT FRAME

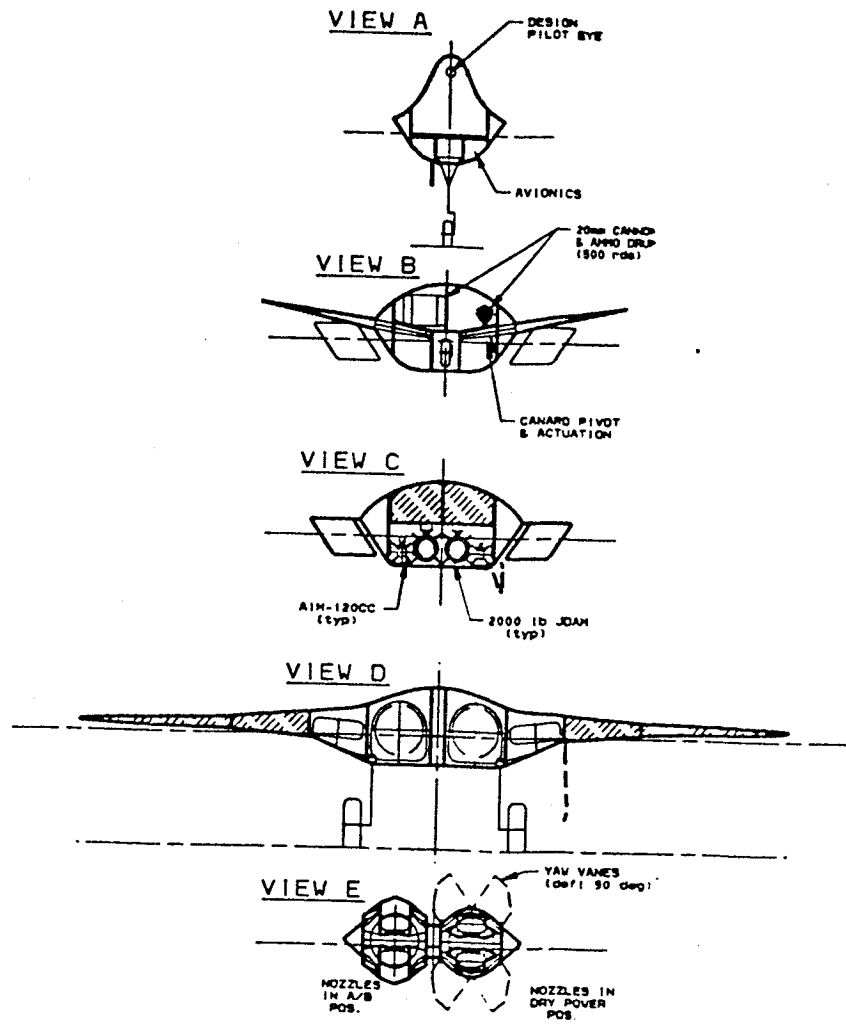



NO.	DESCRIPTION	DATE	APPROVED

# FOLDOUT FRAME 2.

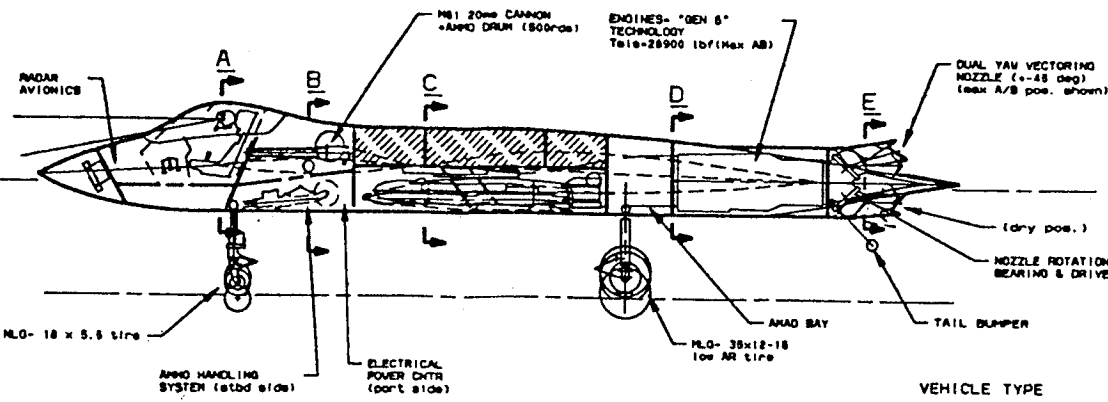
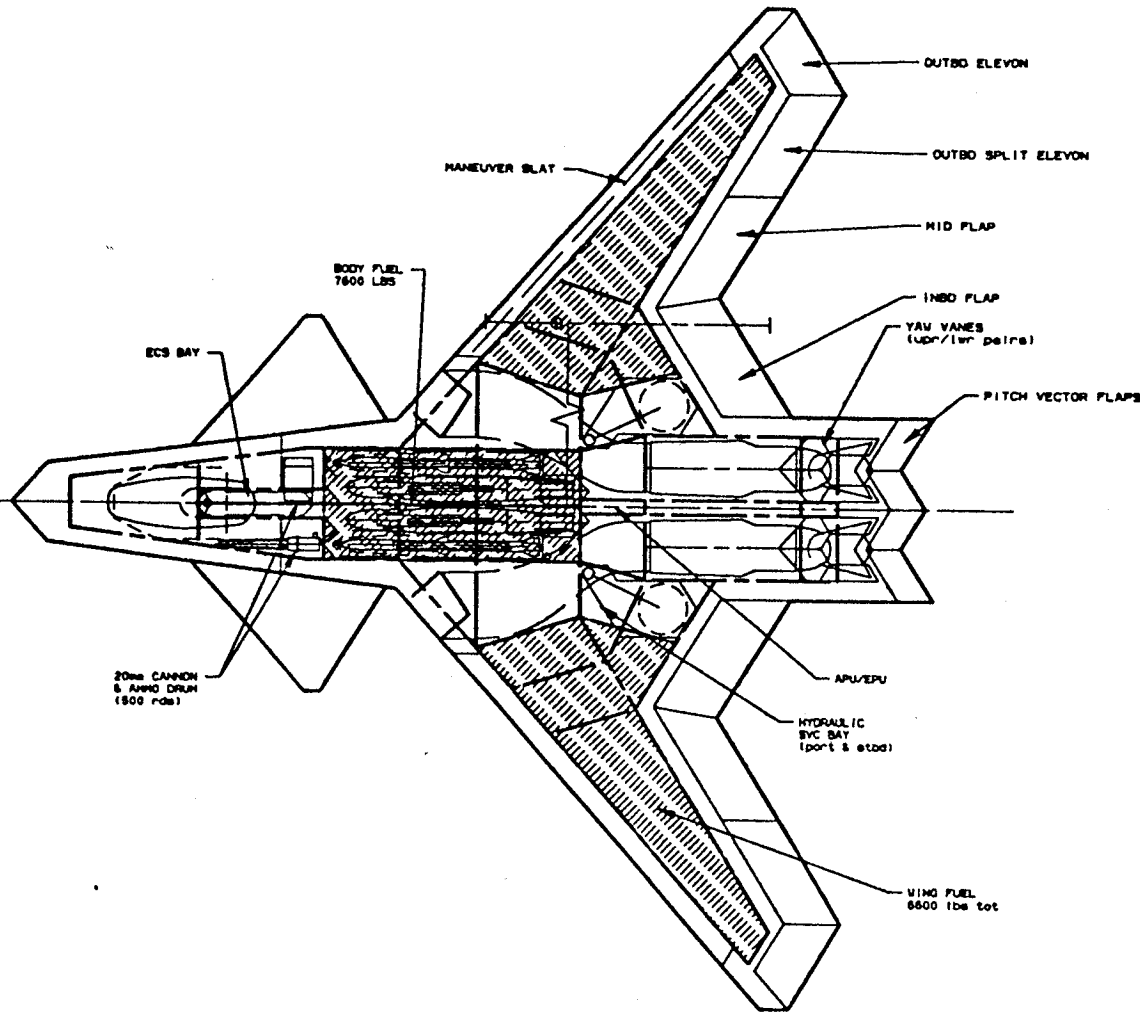

VEHICLE TYPE  
 •HIGH AGILITY  
 •MODERATE OBSERVABLES

ORIGINAL PAGE IS  
 OF POOR QUALITY

USED ON	BY	DATE	<b>BOEING</b> CORPORATE OFFICES SEATTLE, WA 98104
MODEL	NO.		
REV. NO.	BY		INBOARD PROFILE MODEL 988-119 MULTI-ROLE CONFIG
CHG. NO.	BY		BITTECH CODE 066 068
GROUP ONE	BY		J 81205 ASC 988-119-2
CONFIG	BY		SCALE 1/40 PIN X

ASC 988-119-2



<b>GROUP WEIGHT STATEMENT</b>			
MISSION: Multi-role Mission	WEIGHT (LB)	NOSE STATION	0 IN
MODEL: 988-119 HiA/MedLO		WING MAC	191 IN
		LEMAC	334 IN
		BODY LENGTH	644 IN
		BODY STATION	PERCENT MAC
WING	6423	425	
HORIZONTAL TAIL	408	196	
BODY	6488	366	
MAIN GEAR	1249	408	
NOSE GEAR	308	122	
AIR INDUCTION	581	375	
ENGINE SECTION	275	499	
YAW VANES	294	540	
<b>TOTAL STRUCTURE</b>	<b>16026</b>	<b>390</b>	
ENGINES	3100	499	
AMADS	200	427	
ENGINE CONTROLS	40	312	
STARTING SYSTEM	80	462	
FUEL SYSTEM	1004	358	
VECTORING NOZZLES	1529	568	
<b>TOTAL PROPULSION</b>	<b>5953</b>	<b>489</b>	
FLIGHT CONTROLS	1267	478	
APU	210	540	
INSTRUMENTS	270	130	
HYDRAULICS	588	454	
ELECTRICAL	618	345	
AVIONICS	1700	180	
ARMAMENT	204	230	
FURNISHINGS & EQUIPMENT	371	209	
AIR CONDITIONING	659	210	
ANTI-ICE	10	90	
LOAD & HANDLING	10	366	
<b>TOTAL FIXED EQUIPMENT</b>	<b>5906</b>	<b>306</b>	
<b>WEIGHT EMPTY</b>	<b>27885</b>	<b>393</b>	<b>31.0%</b>
CREW	215	125	
CREW EQUIPMENT	40	125	
OIL & TRAPPED OIL	100	472	
TRAPPED FUEL	213	358	
GUN INSTALLATION	252	230	
LAUNCHERS/EJECTORS	700	310	
AMMO CASES	90	230	
<b>NON-EXP USEFUL LOAD</b>	<b>1610</b>	<b>280</b>	
<b>OPERATING WEIGHT</b>	<b>29495</b>	<b>387</b>	<b>27.7%</b>
BOMBS/MISSILES	4990	314	
AMMO EXPENDABLE	110	230	
FUEL	14205	358	
<b>GROSS WEIGHT</b>	<b>48800</b>	<b>370</b>	<b>19.0%</b>





Nose @ BS 0  
LEMAC @ BS 334  
MAC Length = 191 In.  
AC @ 29.3% MAC

**C.G. MOVEMENT RELATIONSHIP  
TO AIRCRAFT WEIGHT**

Model 988-119 HIA/MedLO

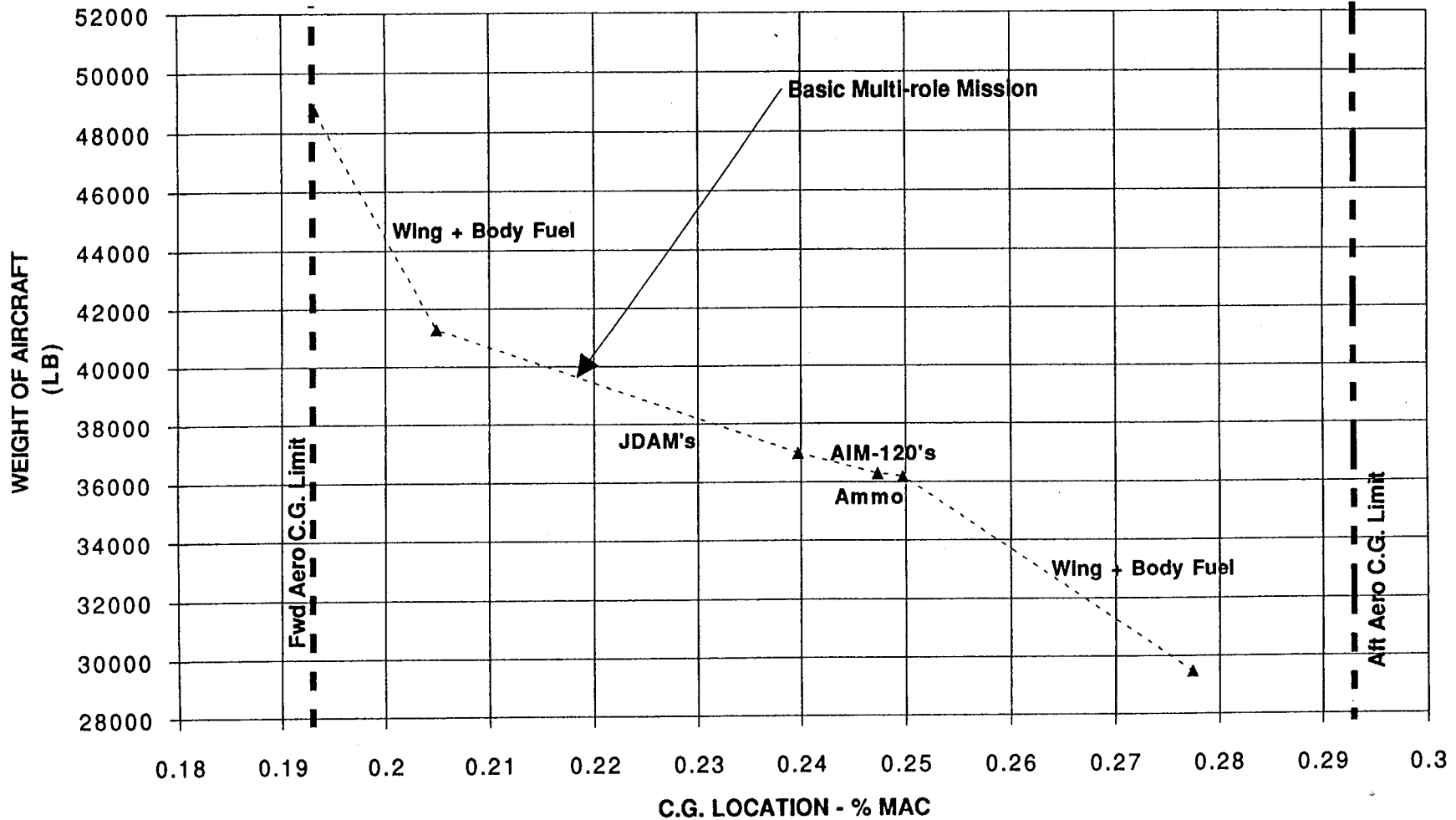

143

ORIGINAL PAGE IS  
OF POOR QUALITY

### Inertia Data at Combat Weight

		<b>M/R Model</b>
<b>Parameter</b>	<b>Units</b>	<b>988-119</b>
		<b>HiA/ModLO</b>
<b>Combat Weight</b>	<b>lbs</b>	41300
<b>Longitudinal C.G. (Body Sta)</b>	<b>in.</b>	373
<b>Vertical C.C. (from static ground line)</b>	<b>in.</b>	74
<b>Ixx Roll Inertia</b>	<b>slug-ft<sup>2</sup></b>	63171
<b>Iyy Pitch Inertia</b>	<b>slug-ft<sup>2</sup></b>	123726
<b>Izz Yaw Inertia</b>	<b>slug-ft<sup>2</sup></b>	204232
<b>Ixz Product of Inertia</b>	<b>slug-ft<sup>2</sup></b>	1234

## Aircraft Geometry

Thrust-to-Weight	=	1.10	Wing-Loading	=	56.0
Takeoff Gross Weight	=	46756.4	Reference Area	=	834.9
Wetted Area	=	2634.7	Swet/Sref	=	3.16

## Body Geometry

Fineness Ratio	=	7.00			
Length	=	53.19	Width	=	8.56
Wetted Area	=	1110.0	Volume	=	992.7

## Wing Geometry

Area	=	834.9	Wetted Area	=	1210.7
Aspect Ratio	=	3.97	Taper Ratio	=	0.00
Span	=	57.57	Mean Aero Chord	=	19.34
Mean t/c	=	0.05			
Sweep Angles					
Leading Edge	=	42.00			
Quarter Chord	=	32.96			
Trailing Edge	=	-6.12			

NOTE: ARPITCH= 8.56, ARWE= 3.97 Wing STABLE in Pitch at High Angles-of-Attack

## Horizontal Tail Geometry

Area	=	156.9	Wetted Area	=	313.9
Aspect Ratio	=	2.40	Taper Ratio	=	0.00
Span	=	19.40	Mean Aero Chord	=	10.78
Mean t/c	=	0.05			
Sweep Angles					
Leading Edge	=	42.00			
Quarter Chord	=	25.81			
Trailing Edge	=	-37.46			

## Engine Geometry

Engine Scale	=	0.6491			
Engine Diameter	=	23.99	Capture Reference Area	=	5.42
Sea-Level Static Thrust	=	25716.0	Nozzle Base Drag Reference Area	=	60.76
Engine Weight	=	2226.2			

Weight Statement	Weight (LBS)	Weight Fraction	Volume (cu ft)	CG (ft)	Moment (ft/lb)
<b>Airframe Structure</b>					
Fuselage.....	6425.	0.1374	64.	28.27	181641.
Wing.....	6262.	0.1339	63.	30.17	188946.
Canard.....	0.	0.0000	0.	0.00	0.
Horizontal Tail.....	539.	0.0115	5.	0.00	0.
Vertical Tail(s).....	0.	0.0000	0.	0.00	0.
Engine Mounts.....	159.	0.0034	2.	49.28	7844.
Inlet(s) and Duct(s).....	421.	0.0090	53.	47.35	19938.
Exhaust Duct(s).....	0.	0.0000	13.	0.00	0.
Pivots.....	0.	0.0000	0.	0.00	0.
Main Landing Gear.....	1227.	0.0263	34.	32.16	39476.
Nose Gear.....	305.	0.0065	12.	19.88	6058.
Total	15339.	0.3281	245.	28.94	443904.
<b>Propulsion System</b>					
Engine(s) and Nozzle(s).....	3881.	0.0830	17.	49.28	191259.
Engine Start and Control.....	120.	0.0026	3.	30.18	4074.
Fuel Tanks.....	387.	0.0083	18.	30.32	11724.
Fuel Pumps.....	21.	0.0004	1.	30.32	630.
Fuel Distribution System.....	249.	0.0053	6.	30.32	7549.
Air-Refueling System.....	63.	0.0013	2.	30.32	1819.
Fuel Inerting System.....	59.	0.0013	1.	30.32	1787.
Gear Box and Accessories.....	200.	0.0043	4.	49.28	7392.
Total	4980.	0.1065	51.	45.43	226234.
<b>Fixed Equipment</b>					
Instruments.....	270.	0.0058	7.	23.57	6365.
Surface Controls.....	1419.	0.0304	35.	24.34	34537.
Crew Accomodations.....	401.	0.0086	70.	19.50	7823.
Armaments.....	1179.	0.0252	39.	30.32	35745.
Avionics.....	1725.	0.0369	33.	21.28	36701.
Electrical System.....	688.	0.0147	17.	18.19	12510.
Hydraulics and Pneumatics.....	423.	0.0091	11.	29.19	12359.
Radar Absorption Material.....	0.	0.0000	0.	0.00	0.
Auxiliary Power System.....	182.	0.0039	6.	0.00	0.
Airconditioning and De-Icing....	835.	0.0179	42.	10.31	8611.
Total	7122.	0.1523	260.	21.71	154651.
Empty Weight.....	27440.	0.5869	0.	30.06	824789.
<b>Operational Items</b>					
Crew.....	200.	0.0043	3.	11.08	2216.
Trapped Fuel and Oil.....	351.	0.0075	7.	39.80	13951.
Gun and Provisions.....	342.	0.0073	7.	0.00	0.
Operational Empty Weight.....	28333.	0.6060	0.	0.00	0.
<b>Payload</b>					
Ammunition.....	110.	0.0024	4.	0.00	0.
Air-to-Air Missles.....	690.	0.0148	65.	0.00	0.
Air-to-Ground Munitions.....	4300.	0.0920	97.	30.32	130369.
Total	5100.	0.1091	166.	0.00	0.
<b>Mission Fuel</b>					
Wing Fuel.....	10896.	0.2330	224.	0.00	0.
Body Fuel.....	2427.	0.0519	50.	0.00	0.
External Fuel.....	0.	0.0000	0.		
Design Gross Weight.....	46756.	1.0000	1823.	30.32	824789.

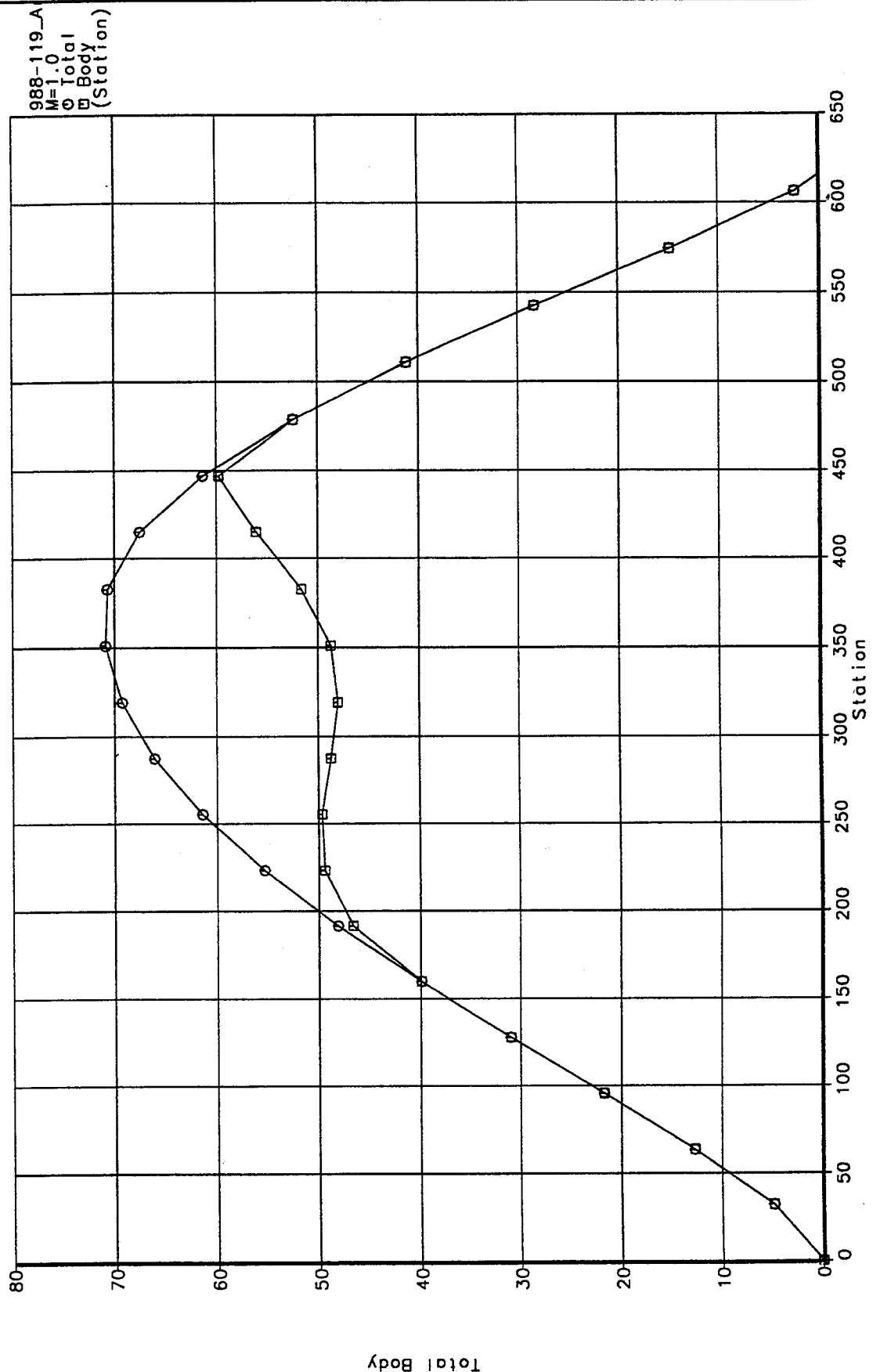

Sat Jul 16 14:10:08 1994

CALC				R.Engelbeck	7/16/94	REVISED	DATE	988-119 High Agility, Moderate Observables Target Cross Sectional Area Distribution	THE BOEING COMPANY	PAGE 147
CHECK										
APPD.										
APPD.										

FAST AERO DATA

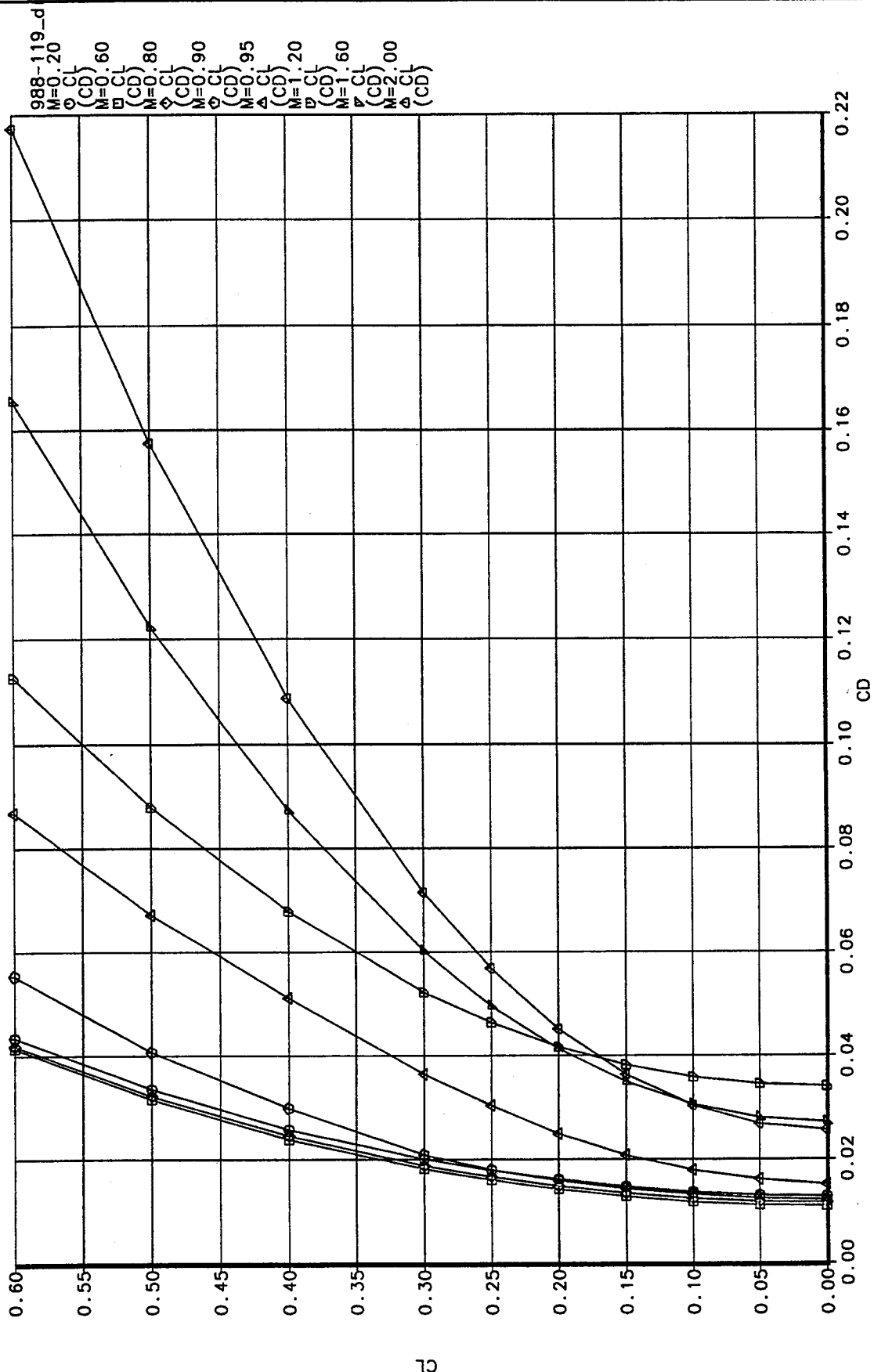

70

CALC	R.Engelbeck	7/16/94	REVISED	DATE
CHECK				
APPD.				
APPD.				

988-119 High Agility, Moderate Observables  
Cruise Drag Polar

THE BOEING COMPANY

Design Mission Segment Performance Breakdown

Initial Weight	Final Weight	Fuel Burned	Time (min.)	Range (n.mi.)	Mach	Altitude (feet)	CL	CD	Power Setting	Net Thrust	Fuel Flow	Error Code
Warm-up and taxi												
46756.	46486.	270.0	10.00	0.0	0.000	0.	0.248	0.0151	0.040	1331.	1620.	0
Warm-up and taxi												
46486.	46369.	117.9	0.25	0.0	0.000	0.	0.248	0.0151	1.000	33264.	28289.	0
Warm-up and taxi												
46369.	45936.	432.4	0.25	0.0	0.300	0.	0.248	0.0151	2.000	54610.	103772.	0
Acceleration from Mach 0.300 to Mach 0.945												
45936.	45310.	626.5	0.32	2.1	0.945	0.	0.044	0.0111	2.000	65309.	136132.	0
Climb from 0.0 ft. to 42902.8 ft. at 228.7 ft/sec												
45310.	43700.	1609.7	1.62	10.8	0.844	42903.	0.241	0.0167	2.000	17925.	34701.	0
Cruise at Mach 0.800												
43700.	39845.	3855.5	88.07	672.9	0.800	40226.	0.287	0.0186	0.317	2698.	2570.	0
Cruise at Mach 0.880												
39845.	39296.	548.7	5.55	50.0	0.880	20000.	0.090	0.0118	0.235	5190.	5927.	0
Drop 4300.00 lbs of expendables												
39296.	34996.	0.0	0.00	0.0	0.880	20000.	0.090	0.0118	0.235	5190.	5927.	0
One Combat Turn at 18.1 deg/sec and 9.0 g's												
34996.	34904.	91.5	0.28	3.0	0.880	20000.	0.715	0.0768	0.863	39185.	19615.	0
Cruise at Mach 0.880												
34904.	34361.	543.6	5.55	50.0	0.880	20000.	0.079	0.0116	0.232	5122.	5871.	0
One Combat Turn at 18.1 deg/sec and 9.0 g's												
34361.	34194.	166.9	0.55	3.0	0.880	20000.	0.702	0.0717	0.806	39185.	18207.	0
Climb from 20000.0 ft. to 48574.6 ft. at 199.2 ft/sec												
34194.	33331.	862.5	1.37	9.9	0.830	48575.	0.272	0.0185	0.806	12449.	24121.	0
Cruise at Mach 0.840												
33331.	30552.	2779.5	79.31	640.1	0.840	49934.	0.317	0.0209	0.376	2112.	2057.	0
Loiter at 0. ft and max L/D of 16.45												
30552.	29763.	788.3	20.00	69.3	0.314	0.	0.248	0.0151	0.054	1833.	2354.	0
Total Mission Fuel = 12693. lbs Reserve Fuel = 635. lbs												

149



26	WEIGHT	%Fuel	Payload	DeltaF	Pset	Mach	Altitude	Mach	Altitude	Require	Actual
xNegPs	37559.61	0.60	1120.00	0.00	2.00	0.60	15000.00	0.00	0.00	0.00	38.52
CCEL	36859.06	0.60	1120.00	0.00	2.00	0.90	40000.00	1.50	40000.00	60.00	56.89
axRC	37559.61	0.60	1120.00	0.00	2.00	0.60	50000.00	0.00	0.00	500.00	6438.28
wFuel	55267.35	0.00	1120.00	0.00	2.00	0.60	50000.00	0.00	0.00	500.00	36671.63
LOAD2	37559.61	0.60	1120.00	0.00	2.00	0.90	20000.00	0.00	0.00	9.00	9.00
LOAD3	37559.61	0.60	1120.00	0.00	2.00	0.90	30000.00	0.00	0.00	9.00	9.00
LOAD4	37559.61	0.60	1120.00	0.00	2.00	1.20	30000.00	0.00	0.00	9.00	9.00
LOAD1	37559.61	0.60	1120.00	0.00	2.00	0.60	10000.00	0.00	0.00	6.00	6.77
LOAD2	37559.61	0.60	1120.00	0.00	2.00	0.90	10000.00	0.00	0.00	9.00	9.00
LOAD3	37559.61	0.60	1120.00	0.00	2.00	0.60	20000.00	0.00	0.00	4.40	4.65
LOAD4	37559.61	0.60	1120.00	0.00	2.00	0.90	20000.00	0.00	0.00	7.00	8.72
LOAD5	37559.61	0.60	1120.00	0.00	2.00	1.20	20000.00	0.00	0.00	6.80	7.50
LOAD6	37559.61	0.60	1120.00	0.00	2.00	0.90	30000.00	0.00	0.00	5.00	5.75
LOAD7	37559.61	0.60	1120.00	0.00	2.00	1.20	30000.00	0.00	0.00	5.00	5.64
S1	37559.61	0.60	1120.00	0.00	2.00	0.60	0.00	0.00	0.00	900.00	974.80
S2	37559.61	0.60	1120.00	0.00	2.00	0.90	0.00	0.00	0.00	1300.00	1457.44
S3	37559.61	0.60	1120.00	0.00	2.00	0.60	10000.00	0.00	0.00	650.00	721.41
S4	37559.61	0.60	1120.00	0.00	2.00	0.90	10000.00	0.00	0.00	1000.00	1154.14
S4	55267.35	0.60	1120.00	0.00	2.00	1.20	10000.00	0.00	0.00	600.00	998.04
S6	37559.61	0.60	1120.00	0.00	2.00	0.60	20000.00	0.00	0.00	450.00	488.61
S7	37559.61	0.60	1120.00	0.00	2.00	0.90	20000.00	0.00	0.00	800.00	847.78
S8	37559.61	0.60	1120.00	0.00	2.00	1.20	20000.00	0.00	0.00	650.00	671.00
S9	37559.61	0.60	1120.00	0.00	2.00	1.40	20000.00	0.00	0.00	600.00	619.52
S10	37559.61	0.60	1120.00	0.00	2.00	0.90	30000.00	0.00	0.00	550.00	560.22
S11	37559.61	0.60	1120.00	0.00	2.00	1.20	30000.00	0.00	0.00	500.00	561.51
S12	37559.61	0.60	1120.00	0.00	2.00	1.40	30000.00	0.00	0.00	600.00	635.07

## Model 988-118, Medium Agility - Low Observables

As a medium agility, low observable vehicle Model 988-118 is a moderate gross weight single place, subsonic delta wing design powered by two turbofan engines of 30,830 pounds augmented thrust each. The external general arrangement, shown on drawing ASC 988-118-1, is characterized by the moderate leading edge sweep of thirty-eight (38) degrees, nested lower forebody inlet apertures, full span trailing edge elevons, and upper body mounted thrust vectoring exhaust nozzles. The wing leading edge incorporates large powered slats that are used to augment maneuver performance.

Control effectors include the yaw thrust vectoring exhaust nozzles with  $\pm 45$  degrees of deflection, Yaw Vane pairs on the upper and lower surface integrated with the nozzle, and four elevons per semi-span. Elevons are single panel at the most inboard position, with the two outboard panels being split on the wing reference plane.

Inlets are integrated/nested with the lower forebody, and exhaust nozzles are located side-by-side on the upper aft fuselage. Yaw Vane pairs are integrated with the nozzles and on the lower aft body.

The interior layout, shown on inboard profile drawing ASC 988-118-2, accommodates the crew, subsystems, weapons and propulsion system within a low profile body shape. The forebody is conventional in arrangement and includes avionics, crew station, gun system, and subsystems. Center body contents are inlet system, weapons bay, and main landing gear. The aft body provides engine and exhaust system accommodation.

Propulsion system installation features consist of the nested external compression fixed ramp inlets, each feeding a long vertical offset inlet diffuser running over the weapons bay to an engine face.

The exhaust system includes augmentor spray bars, and a fully offset duct to nozzle exit plane. The duct turns through a circular bearing/rotation plane to direct exhaust gas out the nozzle aperture. A significant and challenging risk issue is presented here in this concept of making the rotating nozzle system augmentor capable. A discussion of this issue is contained in Section 7.0, Areas of High Technical Risk.

Nozzle concept is that of a variable throat SERN type that utilizes the upper aft deck as the expansion surface.

All fuel is contained in the main wing panel outboard of the side of body. Provision would be made to protect get-home fuel in each wing tank.



EOEDOUT FRAME 1.

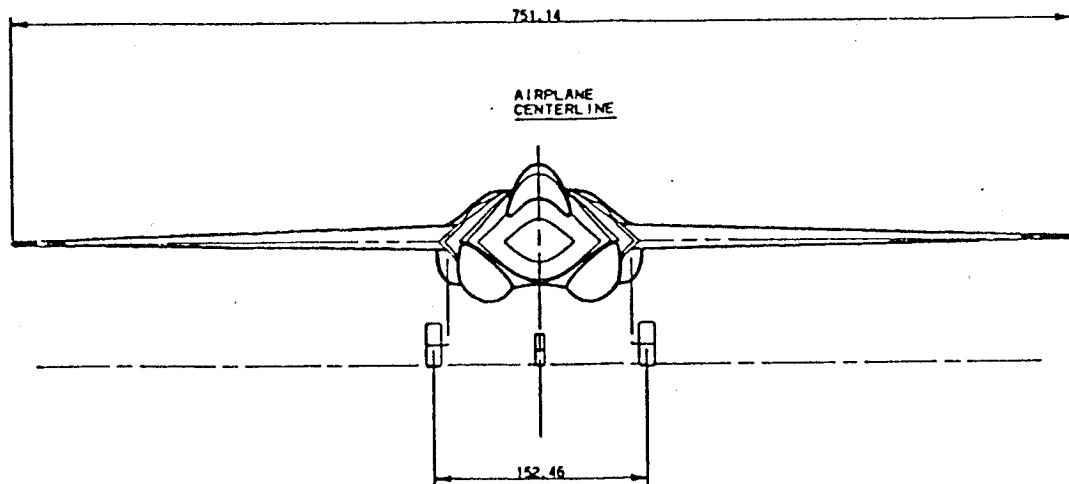

THE INFORMATION CONTAINED  
HEREIN IS UNCLASSIFIED  
DATE 08-14-2010 BY 60322  
AUTHORITY 48 CFR 1.101-11.6



FOLDOUT FRAME

2.

DESIGN PROPRIETARY  
THE INFORMATION CONTAINED HEREIN IS PROPRIETARY AND SHALL NOT BE REPRODUCED OR DISCLOSED IN ANY MANNER FOR ANY PURPOSES EXCEPT UNDER WRITTEN PERMISSION FROM THE DESIGN COMPANY.

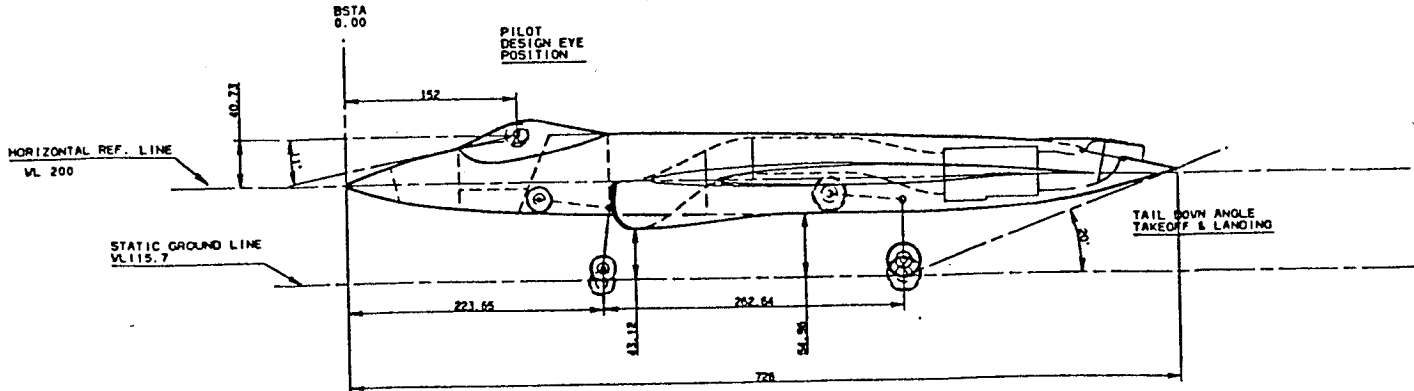
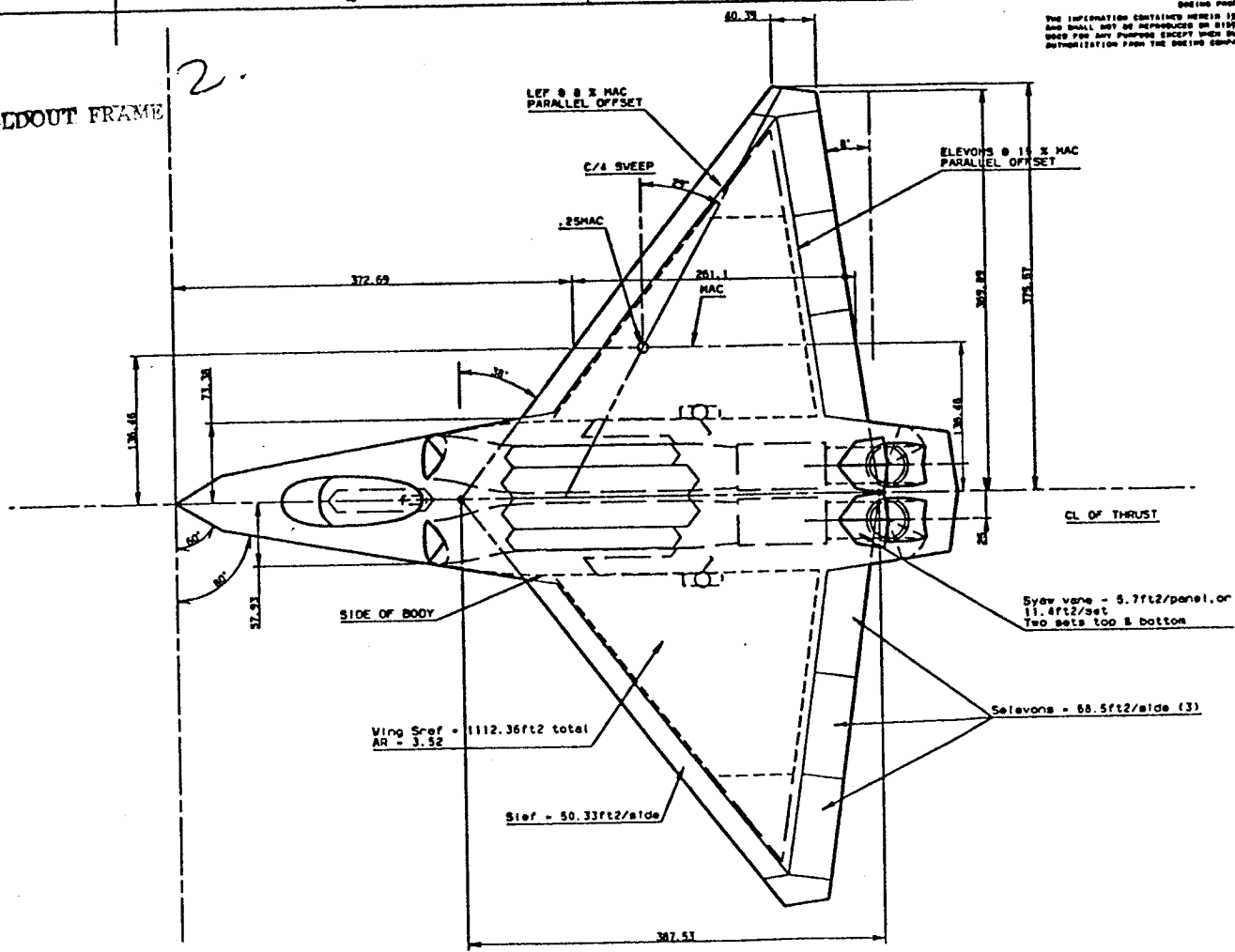



# FOLDOUT FRAME

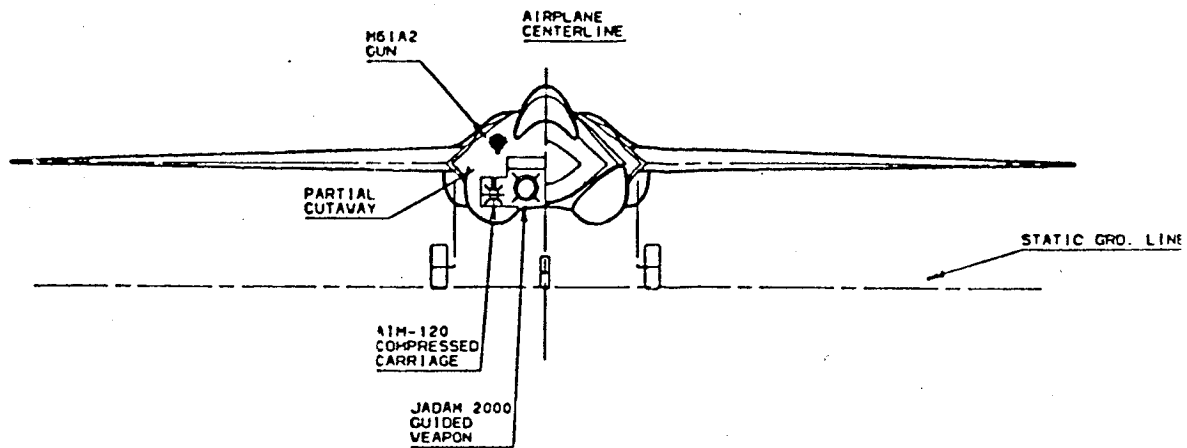

BOEING PROP  
 THE INFORMATION CONTAINED HEREIN IS  
 AND SHALL NOT BE REPRODUCED OR DISCL  
 USED FOR ANY PURPOSE EXCEPT WHEN SUC  
 AUTHORIZATION FROM THE BOEING COMPAN





FOLDOUT FRAME 2

BOEING PROPRIETARY  
 THE INFORMATION CONTAINED HEREIN IS PROPRIETARY TO THE BOEING COMPANY AND SHALL NOT BE REPRODUCED OR DISCLOSED IN WHOLE OR IN PART OR USED FOR ANY PURPOSE EXCEPT WHEN SUCH USER POSSESSES DIRECT WRITTEN AUTHORIZATION FROM THE BOEING COMPANY.

FOLDOUT

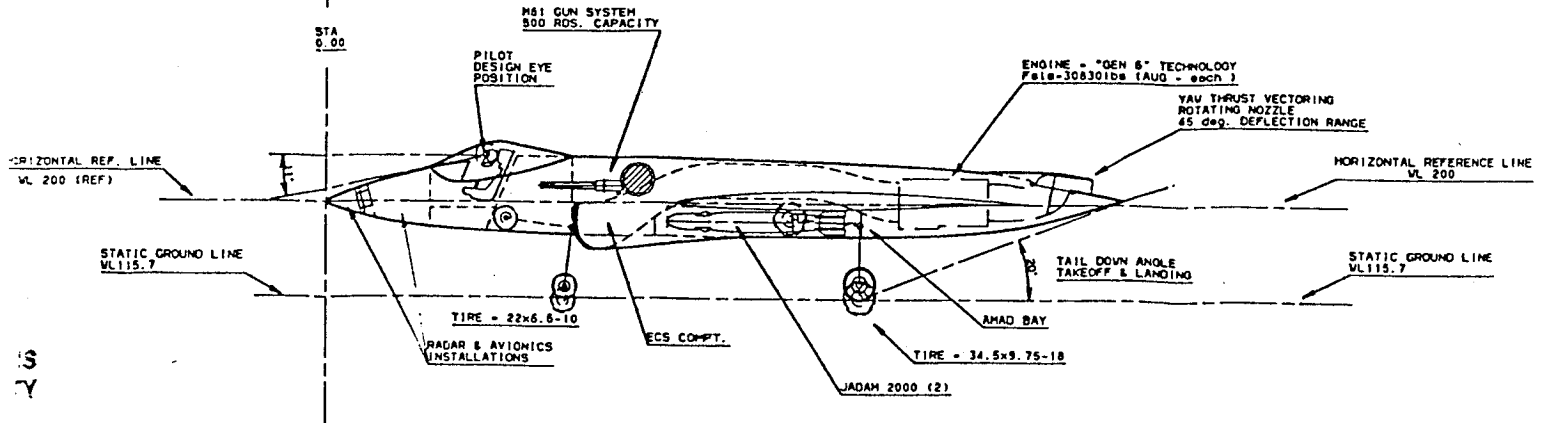
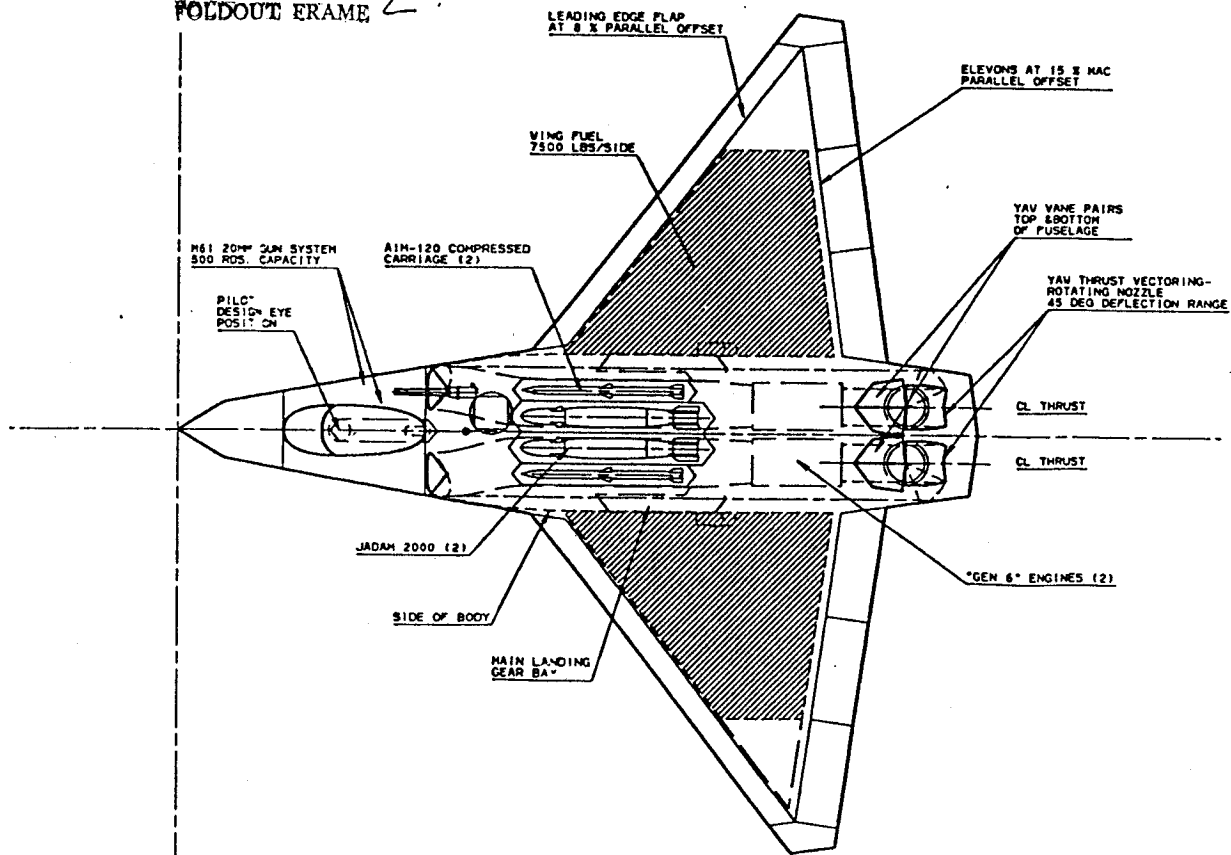



<b>GROUP WEIGHT STATEMENT</b>		<b>NOSE STATION</b>	
<b>MISSION:</b> Multi-role Mission	<b>WEIGHT (LB)</b>	<b>WING MAC</b>	<b>0 IN</b>
<b>MODEL:</b> 988-118 MedA/LO		<b>LEMACH</b>	<b>260 IN</b>
		<b>BODY LENGTH</b>	<b>710 IN</b>
		<b>BODY STATION</b>	<b>PERCENT MAC</b>
WING	6931	499	
BODY	7618	417	
MAIN GEAR	1288	490	
NOSE GEAR	330	225	
AIR INDUCTION	1145	341	
ENGINE SECTION	293	574	
YAW VANES	294	638	
<b>TOTAL STRUCTURE</b>	<b>17899</b>	<b>452</b>	
ENGINES	3352	574	
AMADS	200	501	
ENGINE CONTROLS	40	375	
STARTING SYSTEM	80	536	
FUEL SYSTEM	1020	488	
VECTORING NOZZLES	1412	654	
<b>TOTAL PROPULSION</b>	<b>6104</b>	<b>574</b>	
FLIGHT CONTROLS	1380	542	
APU	210	621	
INSTRUMENTS	270	180	
HYDRAULICS	506	532	
ELECTRICAL	618	396	
AVIONICS	1700	200	
ARMAMENT	204	236	
FURNISHINGS & EQUIPMENT	371	221	
AIR CONDITIONING	658	246	
ANTI-ICE	10	130	
LOAD AND HANDLING	10	417	
<b>TOTAL FIXED EQUIPMENT</b>	<b>5938</b>	<b>350</b>	
<b>WEIGHT EMPTY</b>	<b>29941</b>	<b>457</b>	<b>32.2%</b>
CREW	215	175	
CREW EQUIPMENT	40	175	
OIL & TRAPPED OIL	100	546	
TRAPPED FUEL	214	488	
GUN INSTALLATION	252	236	
LAUNCHERS/EJECTORS	700	393	
AMMO CASES	90	236	
<b>NON-EXP USEFUL LOAD</b>	<b>1611</b>	<b>347</b>	
<b>OPERATING WEIGHT</b>	<b>31552</b>	<b>451</b>	<b>30.1%</b>
BOMBS/MISSILES	4990	394	
AMMO EXPENDABLE	110	236	
FUEL	14248	488	
<b>GROSS WEIGHT</b>	<b>50900</b>	<b>455</b>	<b>31.6%</b>



Nose @ BS 0  
 LEMAC @ BS 372.69  
 MAC Length = 261.1 In.  
 AC @ 31.85% MAC

**C.G. MOVEMENT RELATIONSHIP  
 TO AIRCRAFT WEIGHT**

Model 988-118 MedA/LO

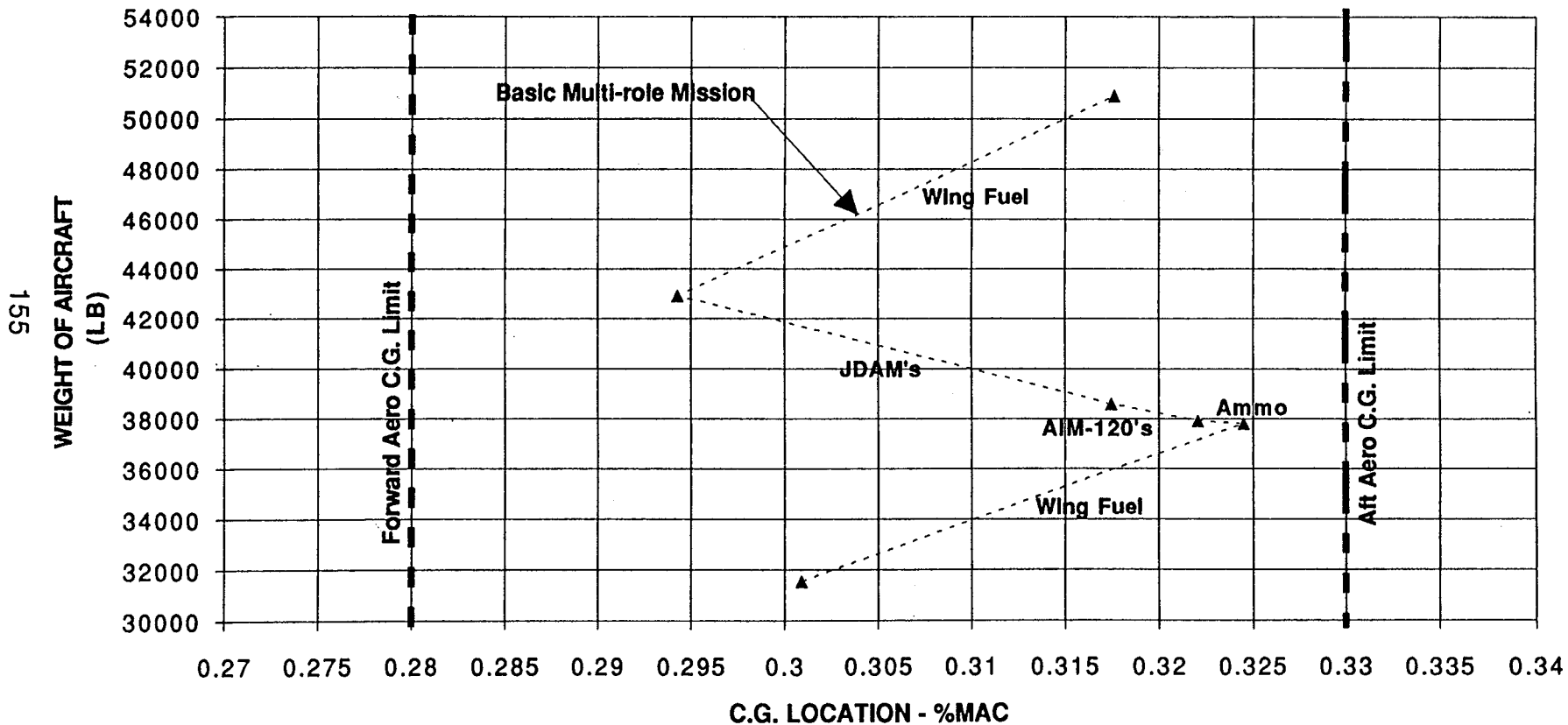

### Inertia Data at Combat Weight

		<b>M/R Model</b>
<b>Parameter</b>	<b>Units</b>	<b>988-118</b>
		<b>MedA/LO</b>
<b>Combat Weight</b>	<b>lbs</b>	<b>43770</b>
<b>Longitudinal C.G. (Body Sta)</b>	<b>in.</b>	<b>449.5</b>
<b>Vertical C.C. (from static ground line)</b>	<b>in.</b>	<b>82</b>
<b>lxx Roll Inertia</b>	<b>slug-ft<sup>2</sup></b>	<b>73135</b>
<b>lyy Pitch Inertia</b>	<b>slug-ft<sup>2</sup></b>	<b>159377</b>
<b>lzz Yaw Inertia</b>	<b>slug-ft<sup>2</sup></b>	<b>249068</b>
<b>lxz Product of Inertia</b>	<b>slug-ft<sup>2</sup></b>	<b>1539</b>

Aircraft Geometry

Thrust-to-Weight	=	1.10	Wing-Loading	=	48.3
Takeoff Gross Weight	=	54049.3	Reference Area	=	1119.0
Wetted Area	=	2982.9	Swet/Sref	=	2.67

Body Geometry

Fineness Ratio	=	7.00	Width	=	8.35
Length	=	58.83	Volume	=	1055.4
Wetted Area	=	1300.0			

Wing Geometry

Area	=	1119.0	Wetted Area	=	1682.9
Aspect Ratio	=	3.52	Taper Ratio	=	0.00
Span	=	62.76	Mean Aero Chord	=	23.77
Mean t/c	=	0.05			

Sweep Angles

Leading Edge	=	38.10
Quarter Chord	=	26.57
Trailing Edge	=	-19.41

NOTE: ARPITCH= 11.10, ARWE= 3.52 Wing STABLE in Pitch at High Angles-of-Attack

Engine Geometry

Engine Scale	=	0.7503	Capture Reference Area	=	6.27
Engine Diameter	=	27.73	Nozzle Base Drag Reference Area	=	60.76
Sea-Level Static Thrust	=	29727.1			
Engine Weight	=	2573.5			



Weight Statement	Weight (LBS)	Weight Fraction	Volume (cu ft)	CG (ft)	Moment (ft/lb)
<b>Airframe Structure</b>					
Fuselage.....	7848.	0.1452	78.	33.49	262844.
Wing.....	9069.	0.1678	91.	40.88	370760.
Canard.....	0.	0.0000	0.	0.00	0.
Horizontal Tail.....	0.	0.0000	0.	0.00	0.
Vertical Tail(s).....	0.	0.0000	0.	0.00	0.
Engine Mounts.....	184.	0.0034	2.	54.62	10056.
Inlet(s) and Duct(s).....	473.	0.0088	57.	52.55	24858.
Exhaust Duct(s).....	0.	0.0000	14.	0.00	0.
Pivots.....	0.	0.0000	0.	0.00	0.
Main Landing Gear.....	1420.	0.0263	42.	35.56	50483.
Nose Gear.....	352.	0.0065	14.	22.04	7768.
Total	19347.	0.3580	297.	37.56	726770.
<b>Propulsion System</b>					
Engine(s) and Nozzle(s).....	4489.	0.0830	18.	54.62	245186.
Engine Start and Control.....	120.	0.0022	3.	32.85	4435.
Fuel Tanks.....	435.	0.0081	-56.	33.53	14594.
Fuel Pumps.....	23.	0.0004	1.	33.53	775.
Fuel Distribution System.....	267.	0.0049	7.	33.53	8958.
Air-Refueling System.....	63.	0.0012	2.	33.53	2012.
Fuel Inerting System.....	63.	0.0012	2.	33.53	2116.
Gear Box and Accessories.....	200.	0.0037	4.	54.62	8193.
Total	5660.	0.1047	-21.	50.57	286270.
<b>Fixed Equipment</b>					
Instruments.....	270.	0.0050	7.	25.34	6841.
Surface Controls.....	1206.	0.0223	30.	34.70	41840.
Crew Accomodations.....	401.	0.0074	70.	20.63	8276.
Armaments.....	1802.	0.0333	60.	33.53	60427.
Avionics.....	1725.	0.0319	33.	23.53	40593.
Electrical System.....	688.	0.0127	17.	20.18	13873.
Hydraulics and Pneumatics.....	496.	0.0092	12.	31.50	15622.
Radar Absorption Material.....	0.	0.0000	0.	0.00	0.
Auxiliary Power System.....	182.	0.0034	6.	0.00	0.
Airconditioning and De-Icing....	963.	0.0178	48.	10.98	10574.
Total	7732.	0.1431	284.	25.61	198045.
Empty Weight.....	32740.	0.6057	0.	36.99	*****
<b>Operational Items</b>					
Crew.....	200.	0.0037	3.	11.08	2216.
Trapped Fuel and Oil.....	405.	0.0075	8.	44.08	17870.
Gun and Provisions.....	342.	0.0063	7.	0.00	0.
Operational Empty Weight.....	33687.	0.6233	0.	0.00	0.
<b>Payload</b>					
Ammunition.....	110.	0.0020	4.	0.00	0.
Air-to-Air Missiles.....	690.	0.0128	65.	0.00	0.
Air-to-Ground Munitions.....	4300.	0.0796	97.	33.53	144192.
Total	5100.	0.0944	166.	0.00	0.
<b>Mission Fuel</b>					
Wing Fuel.....	15262.	0.2824	314.	0.00	0.
Body Fuel.....	0.	0.0000	0.	0.00	0.
External Fuel.....	0.	0.0000	0.		
Design Gross Weight.....	54049.	1.0000	1791.	33.53	*****

988-118-A  
 M=1.0  
 O Total  
 □ Body  
 (Station)

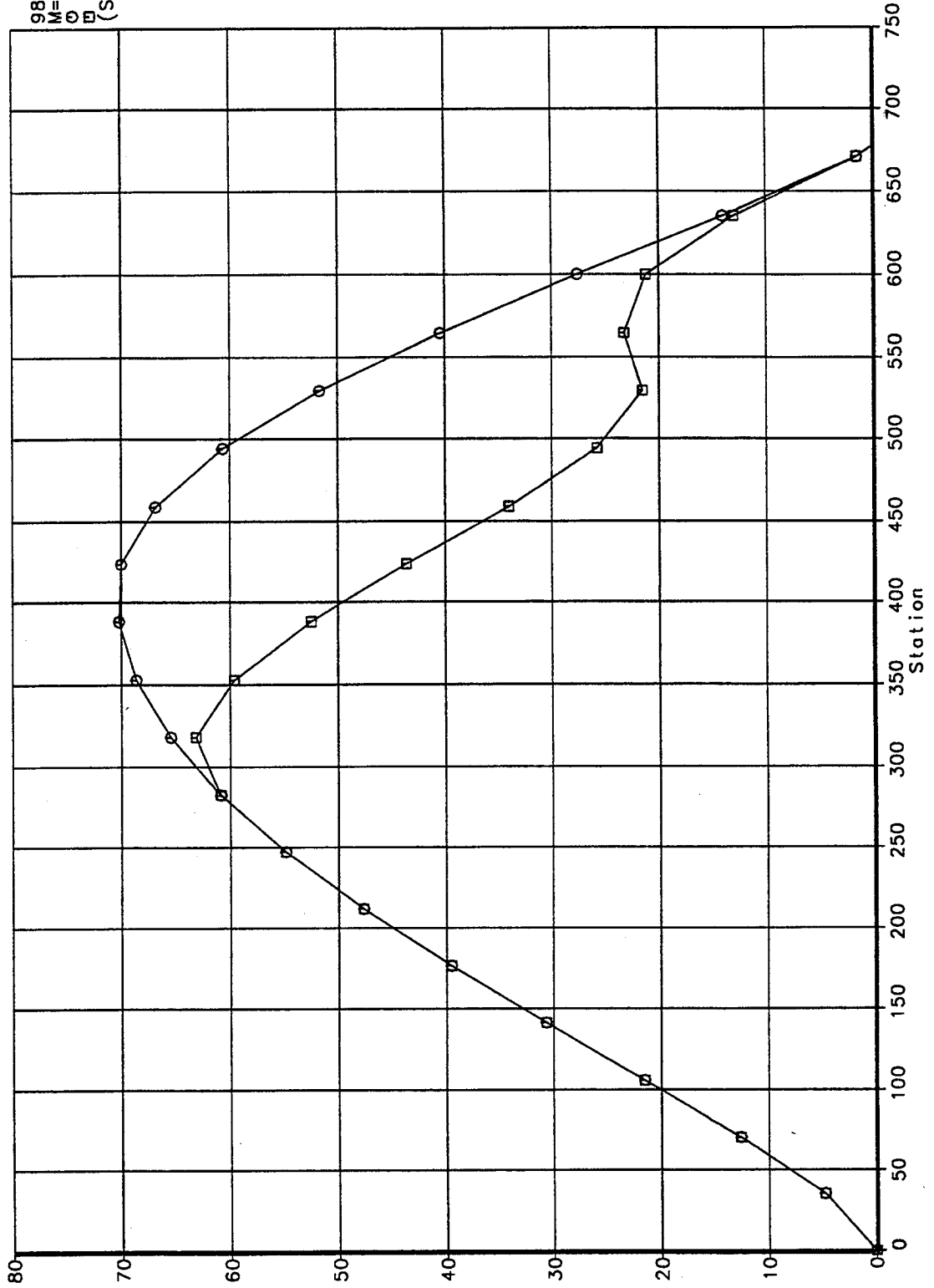

Sat Jul 16 15:03:47 -1994

Total Body

CALC	R.Engelbeck	7/16/94	REVISED	DATE
CHECK				
APPD.				
APPD.				

988-118 Medium Agility, Moderate Observables  
 Target Cross Sectional Area Distribution

THE BOEING COMPANY

FAST AERO DATA

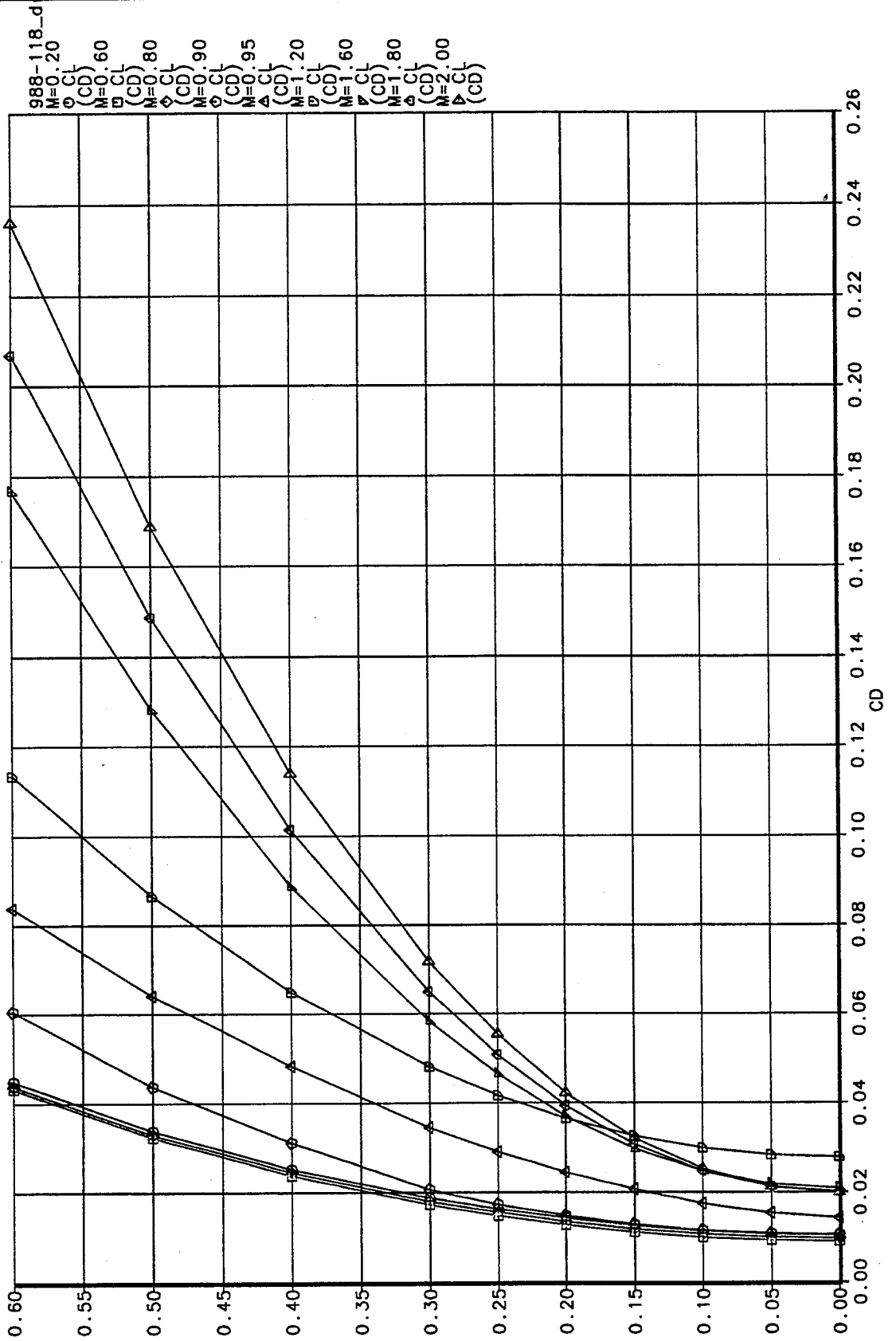

70

CALC	R.Engelbeck	7/16/94	REVISED	DATE	988-118 Medium Agility, Moderate Observables Cruise Drag Polar	
CHECK						
APPD.						
APPD.						
					THE BOEING COMPANY	PAGE 160

Design Mission Segment Performance Breakdown

Initial Weight	Final Weight	Fuel Burned	Time (min.)	Range (n.mi.)	Mach	Altitude (feet)	CL	CD	Power Setting	Net Thrust	Fuel Flow	Error Code
Warm-up and taxi												
54049.	53737.	312.1	10.00	0.0	0.000	0.	0.220	0.0128	0.040	1538.	1873.	0
Warm-up and taxi												
53737.	53601.	136.3	0.25	0.0	0.000	0.	0.220	0.0128	1.000	38452.	32702.	0
Warm-up and taxi												
53601.	53101.	499.8	0.25	0.0	0.300	0.	0.220	0.0128	2.000	63128.	119958.	0
Acceleration from Mach 0.300 to Mach 0.935												
53101.	52391.	710.1	0.31	2.1	0.935	0.	0.039	0.0095	2.000	75423.	157065.	0
Climb from 0.0 ft. to 44111.9 ft. at 216.7 ft/sec												
52391.	50469.	1921.8	1.73	11.7	0.847	44112.	0.218	0.0146	2.000	19804.	38343.	0
Cruise at Mach 0.800												
50469.	46146.	4323.5	87.96	672.1	0.800	41201.	0.259	0.0163	0.323	3035.	2888.	0
Cruise at Mach 0.880												
46146.	45514.	632.1	5.55	50.0	0.880	20000.	0.078	0.0101	0.234	5971.	6828.	0
Drop 4600.00 lbs of expendables												
45514.	40914.	0.0	0.00	0.0	0.880	20000.	0.078	0.0101	0.234	5971.	6828.	0
One Combat Turn at 18.1 deg/sec and 9.0 g's												
40914.	40830.	83.7	0.28	3.0	0.880	20000.	0.624	0.0534	0.696	45297.	17937.	0
Cruise at Mach 0.880												
40830.	40203.	626.7	5.55	50.0	0.880	20000.	0.069	0.0100	0.231	5899.	6770.	0
One Combat Turn at 18.1 deg/sec and 9.0 g's												
40203.	40045.	158.6	0.55	3.0	0.880	20000.	0.613	0.0517	0.673	45297.	17306.	0
Climb from 20000.0 ft. to 49737.7 ft. at 190.2 ft/sec												
40045.	38991.	1053.7	1.49	10.9	0.841	49738.	0.243	0.0161	0.673	13877.	26891.	0
Cruise at Mach 0.832												
38991.	35810.	3180.6	79.97	639.1	0.832	49984.	0.283	0.0182	0.375	2406.	2334.	0
Loiter at 0. ft and max L/D of 17.18												
35810.	34916.	894.3	20.00	68.8	0.311	0.	0.220	0.0128	0.053	2059.	2672.	0
Total Mission Fuel = 14533. lbs Reserve Fuel = 727. lbs												

161

26	WEIGHT	%Fuel	Payload	DeltaF	Pset	Mach	Altitude	Mach	Altitude	Altitude	Require	Actual
							Initial		Final			
xNegPs	44073.33	0.60	1120.00	0.00	2.00	0.60	15000.00	0.00	0.00	-450.00	230.70	
CCEL	43301.95	0.60	1120.00	0.00	2.00	0.90	40000.00	1.50	40000.00		60.00	54.50
axRC	44073.33	0.60	1120.00	0.00	2.00	0.60	50000.00	0.00	0.00		500.00	6519.18
WFuel	55267.35	0.00	1120.00	0.00	2.00	0.60	50000.00	0.00	0.00		500.00	35778.13
LOAD2	44073.33	0.60	1120.00	0.00	2.00	0.90	20000.00	0.00	0.00		9.00	9.00
LOAD3	44073.33	0.60	1120.00	0.00	2.00	0.90	30000.00	0.00	0.00		9.00	9.00
LOAD4	44073.33	0.60	1120.00	0.00	2.00	1.20	30000.00	0.00	0.00		9.00	9.00
LOAD1	44073.33	0.60	1120.00	0.00	2.00	0.60	10000.00	0.00	0.00		6.00	7.37
LOAD2	44073.33	0.60	1120.00	0.00	2.00	0.90	10000.00	0.00	0.00		9.00	9.00
LOAD3	44073.33	0.60	1120.00	0.00	2.00	0.60	20000.00	0.00	0.00		7.00	4.99
LOAD4	44073.33	0.60	1120.00	0.00	2.00	0.90	20000.00	0.00	0.00		6.80	9.00
LOAD5	44073.33	0.60	1120.00	0.00	2.00	1.20	20000.00	0.00	0.00		6.80	7.87
LOAD6	44073.33	0.60	1120.00	0.00	2.00	0.90	30000.00	0.00	0.00		5.00	6.11
LOAD7	44073.33	0.60	1120.00	0.00	2.00	1.20	30000.00	0.00	0.00		5.00	5.88
S1	44073.33	0.60	1120.00	0.00	2.00	0.60	0.00	0.00	0.00		900.00	962.28
S2	44073.33	0.60	1120.00	0.00	2.00	0.90	0.00	0.00	0.00		1300.00	1432.04
S3	44073.33	0.60	1120.00	0.00	2.00	0.60	10000.00	0.00	0.00		650.00	712.09
S4	44073.33	0.60	1120.00	0.00	2.00	0.90	10000.00	0.00	0.00		1000.00	1135.15
S4	44073.33	0.60	1120.00	0.00	2.00	1.20	10000.00	0.00	0.00		600.00	998.04
S4	55267.35	0.60	1120.00	0.00	2.00	1.20	10000.00	0.00	0.00		600.00	998.04
S6	44073.33	0.60	1120.00	0.00	2.00	0.60	20000.00	0.00	0.00		450.00	482.29
S7	44073.33	0.60	1120.00	0.00	2.00	0.90	20000.00	0.00	0.00		800.00	834.48
S7	44073.33	0.60	1120.00	0.00	2.00	1.20	20000.00	0.00	0.00		650.00	705.90
S8	44073.33	0.60	1120.00	0.00	2.00	0.90	20000.00	0.00	0.00		600.00	747.94
S9	44073.33	0.60	1120.00	0.00	2.00	1.40	20000.00	0.00	0.00		600.00	747.94
S10	44073.33	0.60	1120.00	0.00	2.00	0.90	30000.00	0.00	0.00		550.00	551.71
S11	44073.33	0.60	1120.00	0.00	2.00	1.20	30000.00	0.00	0.00		500.00	581.43
S12	44073.33	0.60	1120.00	0.00	2.00	1.40	30000.00	0.00	0.00		600.00	711.57

## **7.0 Critical Assessment**

### **Comparisons**

#### **Air-to-Ground Designs**

The Air-to-Ground designs for high and medium agility collapsed into the same design when the maneuvering devices were added. The Aircraft Design Synthesis results discussed in section 5.0 concluded that when the maneuvering flaps were added, the aircraft thrust-to-weight required to meet both levels of agility were exceeded by the 6.5g sustained turn requirement. Further, the resulting reduction in aircraft thrust-to-weight made the thrust required to meet the lateral sideforce agility metrics the driver in aircraft engine size. Tripling the aircraft engine size to meet the lateral side force agility metric would have a huge impact on aircraft weight and cost. The recommend approach for the next design cycle would be to add large aerodynamic sideforce generators to the designs.

The flying wing configurations in general are extremely vulnerable to spiraling weight growth as the design matures since wing area growth is constrained by the LO philosophy, carrier suitability geometric constraints, and limited center-of-gravity flexibility.

#### **Air-to-Air Designs and Multi-Role Design Drivers**

Designs with significant Air-to-Air capability were driven to high T/W levels because of the maneuver requirements. All the designs had low wing loading (W/S) because of their instantaneous turn requirements. The combination of low wing loading and the resulting wing spans were judged to be near flutter boundaries between 3.5 and 4.5 aspect ratio.

#### **The Impact of Carrier Suitability**

Adding the carrier suitability features to the otherwise identical USAF customer added 14 to 17% to the aircraft empty weight. The low wing loadings, relatively high aspect ratio, and high aircraft thrust-to-weight ratios kept the single-engine rate of climb, catapult, and recovery performance boundaries. The biggest issue for carrier suitability was the general size and weight of the aircraft and the adverse impact it has on deck handling. Some issues remain concerning the impact of large inertias on the rotation rates required to meet the 10 ft. sink requirement during a catapult launch, and the rotation rates required to accomplish a bolter. These issues were not addressed by the simplistic carrier suitability methods used to size the configurations.

#### **The Impact of Observables Design Philosophy**

The observables design philosophy as implemented here was to minimize the number of edges and surfaces on the aircraft. One major impact of this philosophy is reduced maximum lift capability because the flap system of tailless designs must be used for maneuver and trim requirements. This impacts the instantaneous turn capability and carrier launch and recovery speeds.

#### **The Impact of Agility**

Our design intent was to embrace the agility requirements from the outset of the study. Agility drove the layout of the aircraft, the control system philosophy, and control surface sizing. In the case of the Air-to-Ground designs, agility would drive the propulsion system size unless an alternative sideforce generator concept were utilized.

The use of yaw thrust vectoring was key to the achievement of the lateral sideforce agility levels. The use of yaw vectoring was selected over conventional tails because of its effectiveness at high angles-of-attack and low speeds. In addition, thrust vectoring would probably neutralize the issue of

departure. Removal of the vertical tails on all configurations was done to offset the impact in weight from the thrust vectoring system by elimination of the structural weight and drag penalties of the vertical tail. The added benefit of the elimination of the vertical tail is the reduction in side signature. Use of vertical tails would have required that they be canted to keep the side signature down resulting in the cross coupling of the yaw and pitch axis. The use of yaw vectoring without tails would eliminate this undesirable cross coupling.

## Design Interactions

### Observables vs Agility

Design for agility tends to favor concepts with more/larger control effectors, and low inertias. Design for observability tends to drive the number of surfaces that produce a radar return down. Minimizing the number of surfaces drives the designer to aerodynamically inefficient deltoid wings of low aspect ratios. This aerodynamic efficiency drives the wing size up to partially offset the efficiency loss. The larger wing in turn makes the aircraft larger and heavier. The result is an aircraft design that has relatively large inertias and fewer control effectors. Design emphasis on low observables will be a detriment to agility at a given level of maneuverability and mission performance.

### Carrier Suitability vs Agility

The Navy has traditionally been more stringent in the specification of maneuvering requirements that utilize as much of an aircraft flight envelope as possible. The Navy expects their pilots to fly to the edge of this envelope and consequently drives the designer to provide Level 1 flying qualities to the maximum limits of the operational envelope. The Navy requires high departure resistance at high angles-of-attack sufficient to prevent loss of control while maneuvering close to and possible through portions of the flight envelope where control authority traditionally begins to diminish. The Air Force will typically accept limiters to avoid approaching CLmax boundaries throughout the maneuvering envelope. The Air F-16 employs an angle-of-attack limiting schedule which shrinks the left boundary of the energy maneuverability envelope significantly beyond corner speed. Unique maneuver devices are normally found on naval aircraft to ensure maximum maneuvering performance over a full flight envelope. These devices usually take advantage of an already unique low speed, high lift system such as the maneuver flap. All of these features are positive contributions to the agility of an aircraft.

A carrier suitable design is constrained in both weight and size within the operating limitations of an aircraft carrier. Wing fold weight increases with span and tends to drive the wing span of the aircraft down. Minimizing the span minimizes roll inertia for any given weight helping the roll agility of the aircraft. However, the decreased span also has an adverse effect on the roll control power necessary to start and stop the aircraft roll. The increase in aircraft weight to handle the structural loads and additional equipment associated with carrier based operations overwhelm any positive aspects of the Navy designs resulting in aircraft designs less agile than their Air Force counterparts with the same maneuver and mission performance.

### Air-to-Air vs Air-to-Ground Operational Mission Roles

Aircraft designed to the primarily subsonic Air Interdiction mission without any stringent supersonic or Air-to-Air maneuver requirements will typically have large low bypass engines and low aircraft T/W for optimal cruise performance. Aircraft designed to meet the challenging Air-to-Air maneuver requirements will typically have aircraft T/W greater than 1.0 and low bypass ratios. The key technology used in all the agility designs in this study is thrust vectoring. The benefit of thrust vectoring for agility is more effective on the Air-to-Air designs than the Air-to-Ground designs because of the greater T/W of the Air-to-Air designs.



### Wave Drag Levels are Achievable

The specific excess power and sustained turn requirements are ambitious. These requirements represent a ten percent improvement in maneuver capability over F-15 and F-14 fighter capability. To obtain this maneuver capability the design philosophy for wave drag is to work the cross-sectional area distribution as hard as possible to minimize the transonic drag rise and supersonic drag levels. Reduced wave drag will help minimize the engine size required for maneuver and minimize the fuel consumed during supersonic cruise on the defensive counter air mission. Although ideal L-V Haack area distributions are targeted, figure shows a 30 to 44 percent conservatism in the final designs. This conservatism placed the Boeing designs comfortably within the demonstrated levels achieved by past designs.

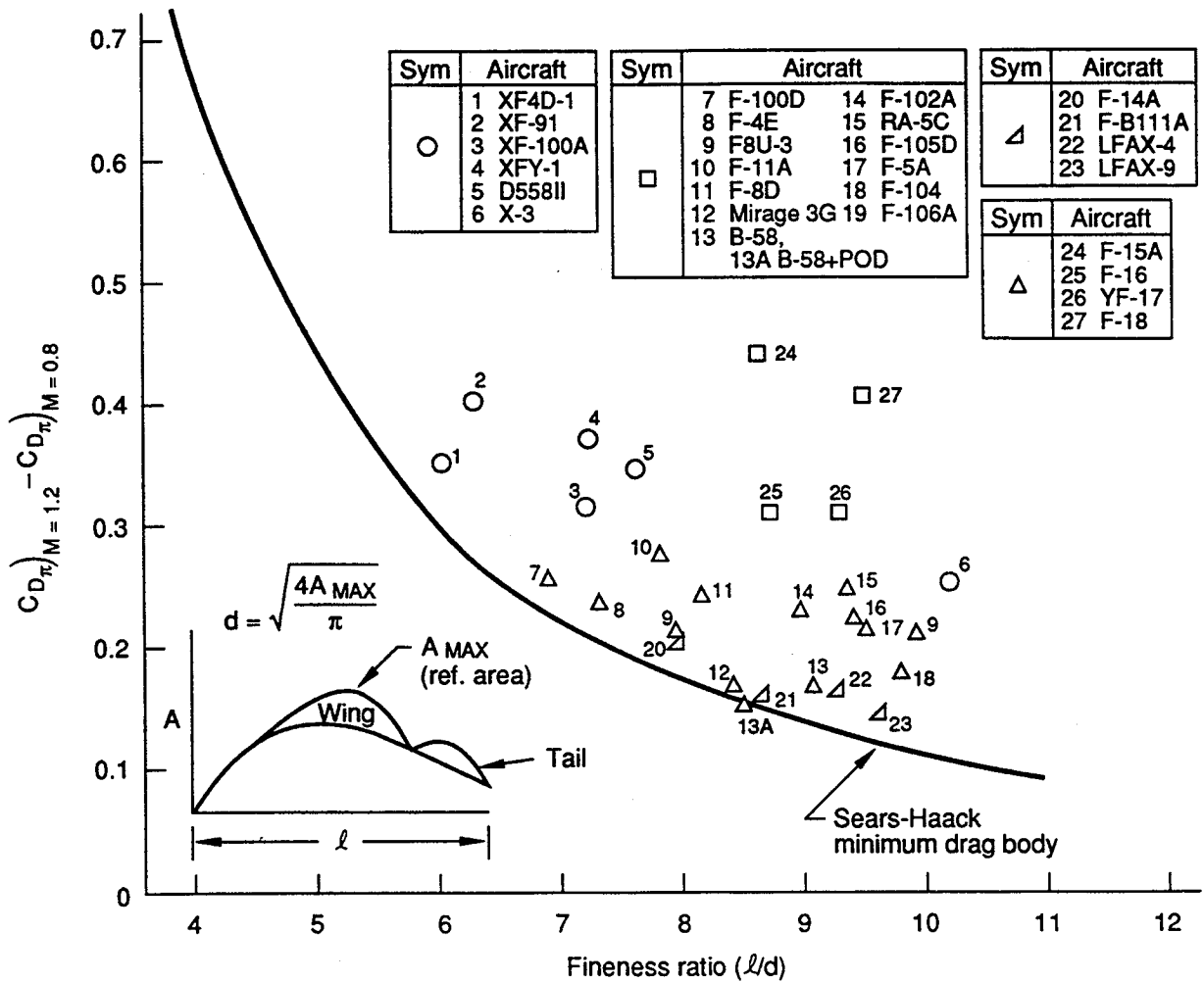

Mission observables agility model no.	Multi-role		Air superiority	
	Low medium 988-118	Medium high 988-119	Low medium 988-114	Medium high 988-115
$C_{D_o}$ @ $M = 0.8$	0.0098	0.0116	0.0101	0.0127
$C_{D_o}$ @ $M = 1.2$	0.0278	0.0340	0.0231	0.0316
$S_{ref}$	1119.0	834.9	1429.1	1014.6
$A_{\pi}$	70.0	71.0	68.0	63.0
$\Delta C_{D\pi}$ - estimated	0.2877	0.2634	0.2732	0.3044
Length	58.83	53.19	60.3	67.14
$A_{max}$	70.0	71.0	68.0	63.0
$d$	9.44	9.51	9.30	8.96
$l/d$	7.41	7.47	7.31	7.03
$\Delta C_{D\pi}$ - Sears-Haack	0.20	0.20	0.21	0.22
$\Delta C_{D\pi_{est}} / \Delta C_{D\pi_{ideal}}$	1.44	1.32	1.30	1.38

Wave Drag Sanity Check

## **6.0 Critical Assessment**

### **Comparisons**

#### **Configuration Design**

An assessment summary, figure 6.0-1, has been made for Models 988-115, -118 and -122/-123. The generalized elements consider long term program issues such as growth capability in mission type and payload size, as being critical to establishing design acceptability. If constrained to the single mission payloads the practicality of these designs is suspect.

## ASSESSMENT SUMMARY

ELEMENT	AIR SUPERIORITY MODEL 988-115	MULTIROLE MODEL 988-118	AIR INTERDICTION MODEL 988-112/-123
<u>Strengths</u>	<ul style="list-style-type: none"> <li>• Control Effector Mix                             <ul style="list-style-type: none"> <li>– Vectoring Nozzle</li> <li>– Canards</li> <li>– Tails</li> <li>– Yaw Vanes</li> </ul> </li> </ul>	<ul style="list-style-type: none"> <li>• Control Effectors                             <ul style="list-style-type: none"> <li>– Vectoring Nozzle</li> <li>directional control power: all altitude</li> <li>– Yaw Vanes</li> </ul> </li> </ul>	<ul style="list-style-type: none"> <li>• Control Effector Mix for Side Force                             <ul style="list-style-type: none"> <li>– Vectoring Nozzles</li> <li>– Yaw Vanes</li> </ul> </li> <li>• Payload/Radius capability</li> </ul>
<u>Weakness</u>	<ul style="list-style-type: none"> <li>• IR missile FOV/FOR</li> <li>• Size drives affordability</li> <li>• Limited internal stores carriage</li> </ul>	<ul style="list-style-type: none"> <li>• IR missile FOV/FOR</li> <li>• Limited internal stores carriage volume</li> </ul>	<ul style="list-style-type: none"> <li>• IR missile FOV/FOR</li> <li>• Limited by growth incorporated for internal payload</li> </ul>
<u>Suitability</u>	<ul style="list-style-type: none"> <li>• External stores capable                             <ul style="list-style-type: none"> <li>– Conformal</li> <li>– Pylon mounted</li> </ul> </li> <li>• Difficult to operate on carrier</li> </ul>	<ul style="list-style-type: none"> <li>• External stores capable on Wing                             <ul style="list-style-type: none"> <li>– Conformal</li> <li>– Pylon mounted</li> </ul> </li> </ul>	<ul style="list-style-type: none"> <li>• Internal sores capability drives bay size &amp; vehicle</li> <li>• External stores not desired alternate</li> </ul>
<u>Achievability</u> • Cost • Supportability • Effectiveness • Signature	<ul style="list-style-type: none"> <li>• Driven by technical issues</li> <li>• Obtainable &amp; sustainable</li> <li>• Close in high probability</li> <li>• Vulnerable to threats - many edges</li> </ul>	<ul style="list-style-type: none"> <li>• Driven by technology</li> <li>• Obtainable &amp; sustainable</li> <li>• Expanded capability</li> <li>• Reduced vulnerability - cleaner design</li> </ul>	<ul style="list-style-type: none"> <li>• Driven by technologies used</li> <li>• Obtainable &amp; sustainable</li> <li>• Broad capability</li> <li>• Low levels are inherent in basic design</li> </ul>

Agility Level				Medium	Medium	High	Medium	High
Observables Level				Low	Low	Moderate	Low	Moderate
Model Number	Mach No	Altitude - ft	Requirement	988-114	988-114A	988-115	988-118	988-119
Maximum Negative Ps	0.6	15000	-100	-16.34	-16.34	-59.37	127.57	-53.54
Acceleration	0.9	40000	60	54.39	54.39	51.53	52.68	51.41
Maximum Rate of Climb	0.6	50000	500	6603.28	6603.28	6620.42	6557	6586.78
Instantaneous Load Factor	0.9	20000	9	9	9	9	9	9
Instantaneous Load Factor	0.9	30000	9	9	9	9	9	9
Instantaneous Load Factor	1.2	30000	9	9	9	9	9	9
Instantaneous Load Factor	0.6	10000	6	6.62	6.62	6.37	7.02	6.4
Sustained Load Factor	0.9	10000	9	9	9	9	9	9
Sustained Load Factor	0.6	20000	4.4	4.51	4.51	4.38	4.76	4.4
Sustained Load Factor	0.9	20000	7	8.55	8.55	8.29	8.85	8.04
Sustained Load Factor	1.2	20000	6.8	7.7	7.7	7.9	7.87	7.52
Sustained Load Factor	0.9	30000	5	5.65	5.65	5.47	5.85	5.3
Sustained Load Factor	1.2	30000	5	5.76	5.76	5.82	5.84	5.54
Specific Excess Power	0.6	0	900	971.6	971.6	964.87	962.06	978.09
Specific Excess Power	0.9	0	1300	1436.88	1436.88	1439.25	1440.38	1481.73
Specific Excess Power	0.6	10000	650	718.98	718.98	713.71	711.58	723.28
Specific Excess Power	0.9	10000	1000	1140.6	1140.6	1140.38	1140.19	1169.86
Specific Excess Power	1.2	10000	600	998.04	998.04	998.04	998.04	998.04
Specific Excess Power	0.6	20000	450	486.46	486.46	482.73	481.7	489.67
Specific Excess Power	0.9	20000	800	838.9	838.9	837.73	837.38	857.7
Specific Excess Power	1.2	20000	650	707.31	707.31	784.85	749.13	789.58
Specific Excess Power	1.4	20000	600	742.55	742.55	817.34	807.19	795.04
Specific Excess Power	0.9	30000	550	554.13	554.13	553.05	553.22	566.33
Specific Excess Power	1.2	30000	500	583.91	583.91	630.31	607.46	633.55
Specific Excess Power	1.4	30000	600	711.26	711.26	755.14	747.13	742.15

170

Chart5

# Instantaneous Turn Rate

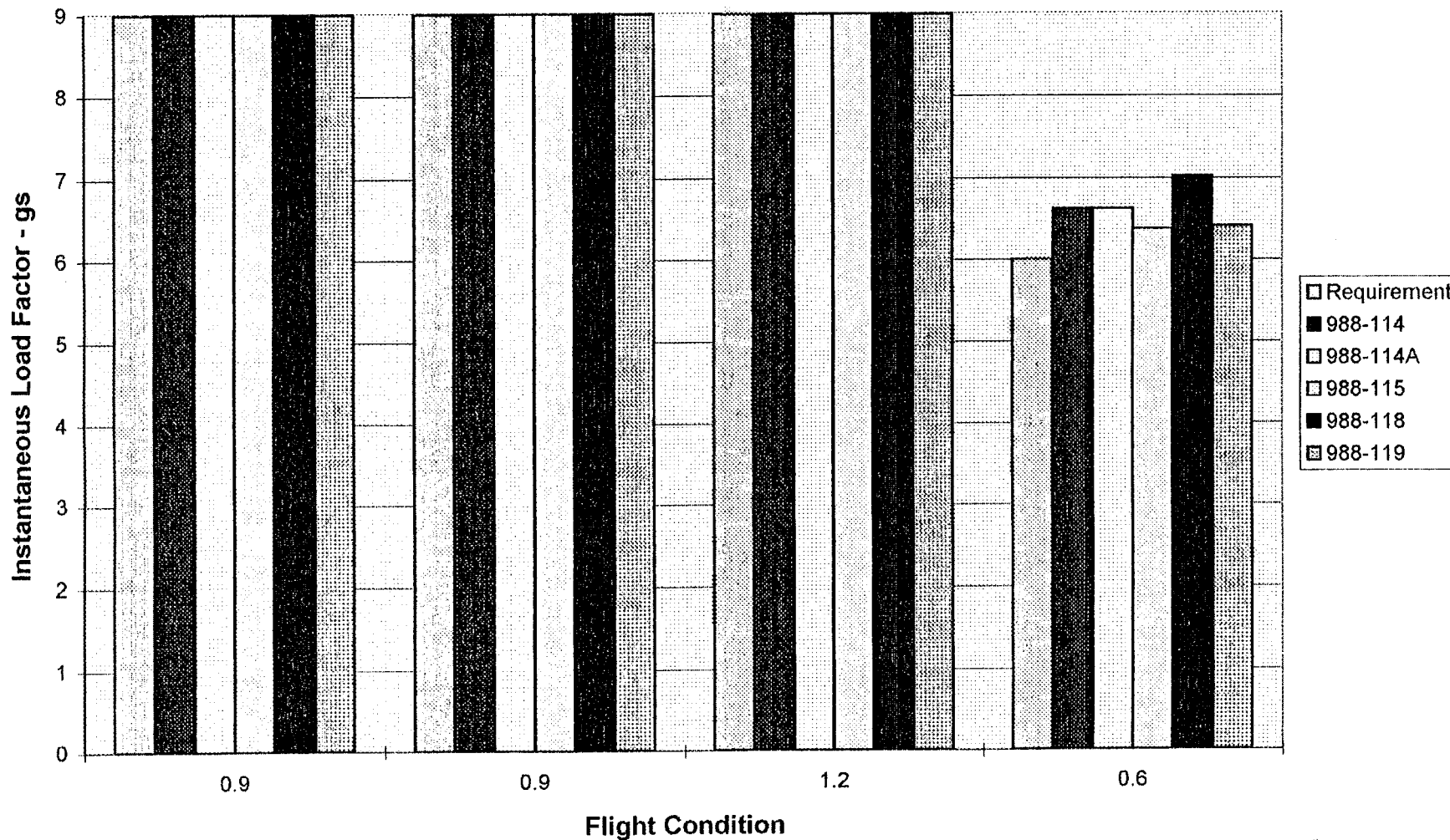

171

Chart4

# Sustained Load Factor Comparison

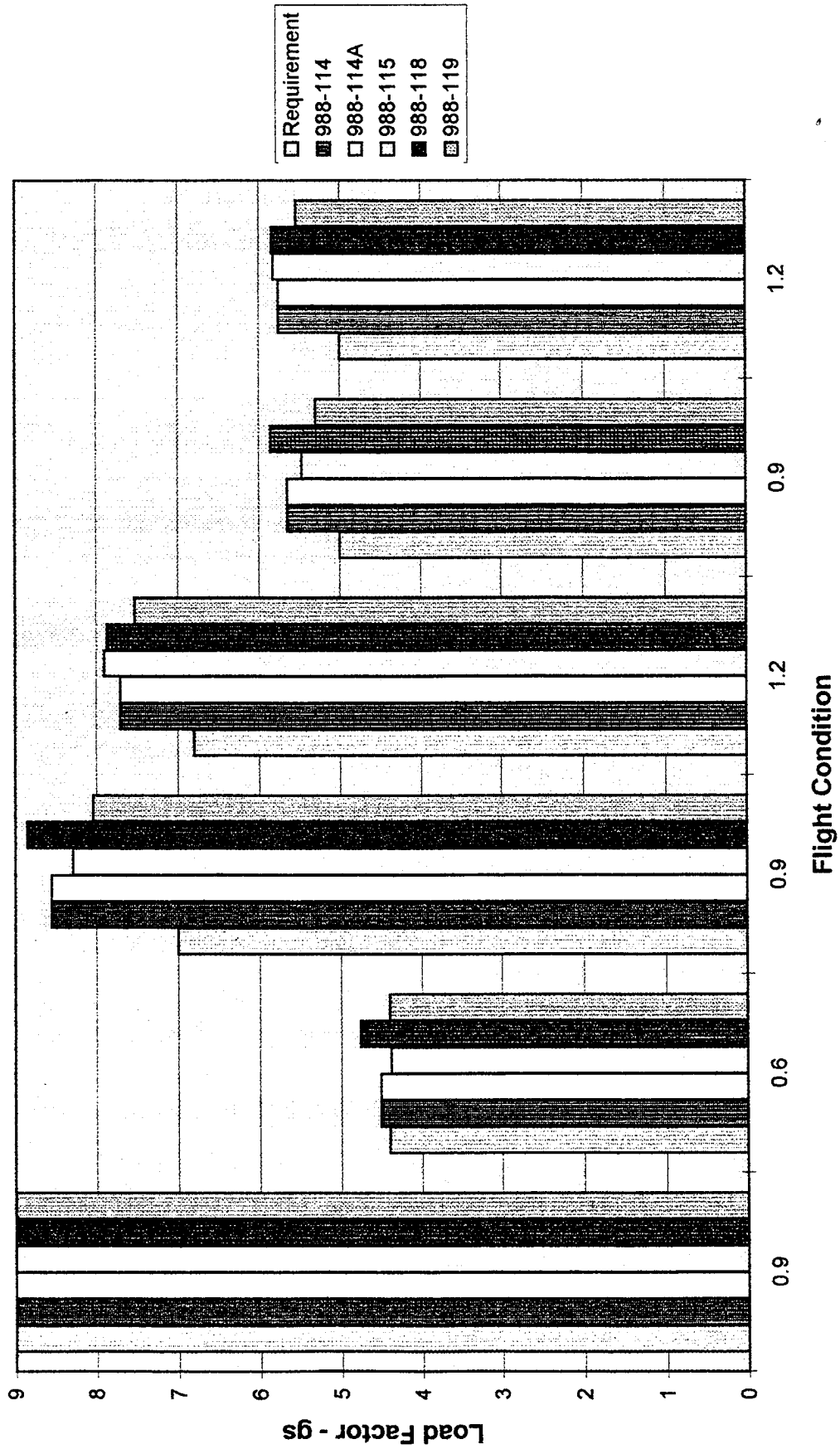
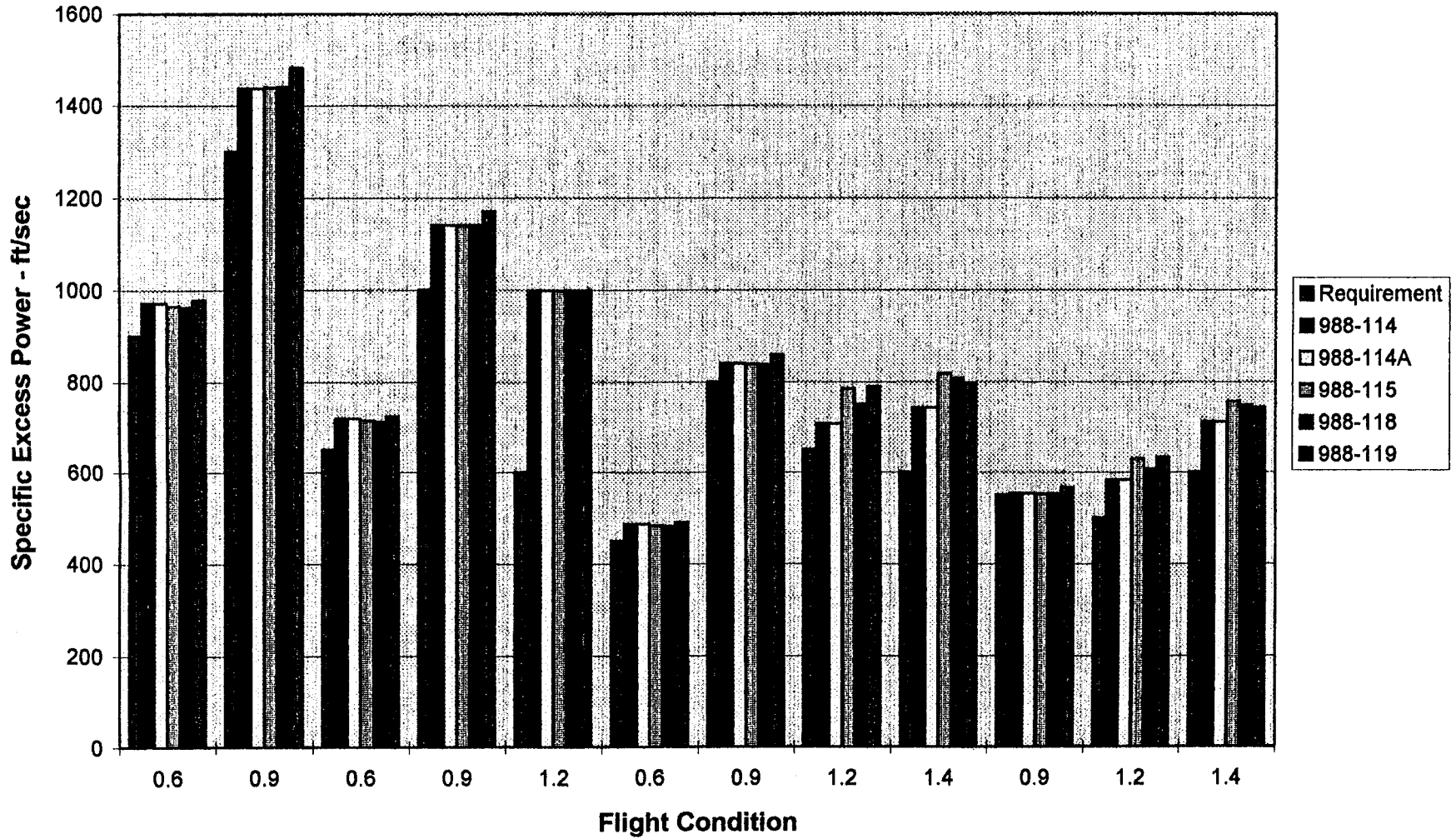

Chart3

# Specific Excess Power Comparison



ORIGINAL PAGE IS  
OF POOR QUALITY

173



	Air-to-ground			Multi-role				Air-to-air			
	A-6E	988-123N	A-12	F-16	988-119	988-119N	F-18	F-15A	988-115	988-115N	F-14
TOGW (lbs)	58,600	80,910	60,000 → 80,000	37,500	48,801	54,704	51,900	50,000	59,549	67,397	74,349
Empty weight (lbs)	25,980	34,961		16,285	27,886	32,033	23,050	26,768	31,746	36,367	41,353
Max. internal fuel (lbs)	15,939	33,596		6,846	14,205	15,923	10,860	11,050	24,026	27,192	16,200
Max. internal payload (lbs)	0	9,100		0	4,990	4,990	0	0	1,800	1,800	0
T/W	.317	.34		.64	1.10	1.10	.61	.96	1.13	1.13	.72
W/S	111	50	45 → 60	125	59	59	130	82	58	58	132
AR	5.311	3.5	3.75	3.0	3.97	3.97	4.0	3.0	3.8	3.8	2.58 → 7.28
Engines	(2) J52-P-8A1B	(2) Advanced A/G	(2) F412 (dry)	(2) F-100	(2) Advanced (A/A)	(2) Advanced (A/A)	(2) F-404	(2) F-100	(2) Advanced (A/A)	(2) Advanced (A/A)	(2) F-110
Span (ft)	53	75	70.27 ft	31.0	57	61	40.4	42.8	63	67	38.2 → 64.1
S <sub>ref</sub> (sq ft)	528.9	1,618	1,317	300	830	931	400	608	1,032	1,167	565
Sustained load factor @ M = 0.6, H = 10,000 ft	-	-	-	5.0	6.77	6.77	5.0	5.2	6.4	6.4	4.8

### Historical Comparisons

## **8.0 Flight Research Needs Assessment**

### **The Value of Agility in Combat Effectiveness**

The single largest uncertainty in designing an agile fighter is quantifying the value of agility in terms of combat effectiveness. In the absence of quantifiable measures of merit, the military has been reluctant to impose specific agility requirements on the aircraft designer. The aircraft industry is reluctant to develop methods or design aircraft to meet requirements their customer has not specifically called out. Over the last few years, programs like X-29, X-31, HARV and VISTA have produced research aircraft that are arguably more agile than current fighter aircraft. On those programs where more than one aircraft exist (like the X-31), 1 vs 1 flight combat simulations and to be conducted with one research vehicle simulating a conventional fighter with the same basic flight characteristics as the fully functional research aircraft. In this way the impact of agility on combat effectiveness can be isolated from other flight characteristics. Issues concerning the impact of agility on combat effectiveness in the M vs N scenario would best be quantified through flight combat simulations using a collection of research aircraft against current inventory fighters. This would help quantify the effect of number of adversaries has on the value of agility.

### **Control Effectors**

Research needs to continue to develop new and creative methods to control aircraft. New challenges such as lateral control of tailless aircraft and concern for the signature characteristics of controls being deflected are only a subset of the research that needs to be conducted.

Wind tunnel tests need to be conducted to quantify the benefits of Tiperons against the heavy weight penalties of attachment. Porous leading and trailing edge devices promise low RCS and reduced mechanical complexity, but more windtunnel testing is needed before the concept is proven and design information developed to effectively implement the concept into aircraft design. Leading edge blowing, leading edge suction, and tangential wing blowing need more windtunnel database development to prove the concepts, quantify the benefits, and determine the blowing requirements and weight penalties. A database of windtunnel data needs to be developed for drag rudders as a function of deflection and wing planform. A windtunnel database of the effectiveness of articulating forebody strakes, nose strakes, chines, and other forebody shapes needs to be developed. All types of forebody jet blowing, slot blowing, and suction need wind tunnel research to quantify their effectiveness and how these concepts are impacted by forebody shape.

The primary attribute of all the designs produced in this design study is the radical amount of yaw thrust vectoring used. Continued development of all thrust vectoring schemes with the objective of proving the use of thrust vectoring as a primary control should be pursued vigorously.

### **Aerodynamics**

Low signature requirements are driving the aircraft designer to simple tailless designs like the B-2 and A-12 configurations. This design philosophy would benefit from research into devices to counter the inherent inefficiencies of low aspect ratio wings with lots of wetted area. Windtunnel testing of vortex flap concepts with sharp and semi-sharp leading edges need to be tested with various planform variations, especially leading edge sweep. Variable camber or mission adaptive wing designs were proven in the MAW and AFTI F-111 program but research into how to implement the concept with composite materials in an environment of emphasized low signature, lower weight, cost limitations needs to be researched. Success in CFD research into predicting transition has direct impact on the successful design of natural laminar flow shapes. Natural laminar flow is one of the few technologies capable of reducing parasite drag, a very important component of drag for aircraft with large wing surfaces like the B-2 and A-12. Research into methods to maintain a smooth surface in a dirty service environment and manufacturing issues need to be addressed for passive laminar flow concepts. In addition, reducing the maintenance requirements, weight, and cost of active laminar flow concepts should continue to be researched. Flight Testing samples, detailed CFD, and windtunnel testing of porous lifting surface technology would help quantify the benefits of reduced shock strength and installation drag penalties on the Mach capability of potential designs.

## Propulsion

One of the early findings of this design study was the importance of engine technology level on the aircraft size and fuel requirements. These aircraft designs, relative to their contemporary counterparts, have long design mission radius requirements coupled with high thrust-to-weight ratios required for maneuver. The resulting strong sensitivity to the propulsion weight and fuel consumption characteristics drove the design team to select the GEN 6+ level of technology to keep the aircraft size down. Fighter engine thrust matching for cruise radius conflicts with ever increasing demands for fighter maneuverability and acceleration. Efforts to reduce fuel consumption in both cruise and combat require cycle optimizations at both low and high power ends of the engine thrust spectrum. IHPTET GEN 6 engine technologies including variable cycle engine/control technologies research should continue to be strongly supported.

## Structures & Materials

Advanced Aluminum-Lithium Alloys and Advanced Titanium alloys have had a history of failures. Advanced Aluminum-Lithium Alloys have failed due to poor ductility. Weldability and crack growth has been the cause of failure for the advanced Titanium Alloys. Unless significant progress is made into these issues and reducing the high cost penalty, these material probably will not see wide spread use. Power metallurgy using current materials still needs further development to realize any savings in manufacturing costs and may not be worth the effort. However, metal matrix composites is potentially a major benefit.

Expect continued research into composite materials technology like graphite based composites. Research on the cost and ease of use of Boron based composites should be emphasized. Research into preventing water contamination of composite materials like Kevlar should be pursued. The use of advanced resins could save weight by improving the materials toughness but manufacturing research will be critical to its success.

## Manufacturing Techniques

Improved materials are nice, but the next breakthroughs will be in new joining and manufacturing methods like welding and co-curing. Advanced manufacturing techniques like superplastic forming, T. welding, composite welding, and Z-pinning all have major potential benefits for future fighters. Still more time and research is needed to realize cost and weight savings using structural techniques such as welded joints, Issogrid, Column Core, and Z-pinning.

## Structural Design Issues

A couple of the concepts developed for this study were arbitrary limited by our discomfort with the potential of encountering the structural flutter boundary. Research into establishing the location of the flutter boundary in conceptual design would help the designer produce a good design without the high cost of higher order studies currently required to establish a flutter boundary. Research into using the control system in an active flutter suppression system would allow the use of more wing aspect ratio, sweep, and less thickness for improved aerodynamic efficiency. This technology needs a flight demonstration on an unmanned drone to prove the technology. Research into design techniques for smart structures could help designers realize weight savings with clever designs, and avoid weight penalties with not so clever designs.

## Avionics

Research into defining a growth path of RF and digital processing upgrades for the JAWG/Pave Piller Class of integrated Avionics would reduce overall development cost while minimizing the weight growth as the system expands. Research into combined multispectral apertures and staring focal plane arrays would help reduce the developmental cost of advanced targeting FLIR, Integrated Nav FLIR/IRST/MLD. Advanced multilayer wafer IC on ceramic substrate, planar slotted radiators, MMIC, and component & substrate integration research would help realize a 50% weight reduction for tiled

**Array Radar. Offboard data management significantly impacts avionics system weight on the aircraft. Research into data fusion and into reducing RCS communications apertures and receiver sensitivity would help realize a 50% weight reduction in avionics. One of the highest risk technologies that could benefit from research is Integrated Sensor Systems (ISS) to produce common RF modules for further reductions in avionics weight.**

## Vehicle Management System

The Vehicle Management System (VMS) is the integration of a large number of subtechnologies. High payoff areas of research are Phototonics, Improved Hydraulic System concepts, and the all Electric Airplane. Subsystem Utilities Integration Technology (SUIT) research would help realize a 50% weight reduction by understanding physical and functional integration, the suitability of different fluids, energy utilization, and advanced packaging.

## Crew Systems

One of the ground rules going into this study is that a single pilot will be able to handle the task loads currently being handled by two man crews. Most of the reductions in pilot workload would be through automation and vastly improved displays. Research into helmet mounted displays, night vision systems, panoramic displays, and 3-D audio would all contribute to the goal of reducing the pilots workload and improving his situational awareness. Additional research into laser-hardening technologies is necessary to protect the pilots survivability and mission effectiveness.

## Weapons

The signature requirements drove the need to carry the design weapons load in internal weapons bays. These internal bays have substantial weight and volume penalties that drive up aircraft size and weight. Research into low signature weapons to replace the current inventory weapons is strongly recommended. The inherent low drag relative to conventional weapons would contribute to smaller, lighter, and cheaper aircraft. Conformal carriage of these reduced signature weapons would reduce pylon weight and interference drags further reducing aircraft size and weight. Research into "All Envelope" Air-to-Air Weapons combined with aircraft agility would significantly improve the effectiveness of fighter in an air-to-air engagement.

## Unique Naval Aircraft Technology Requirements

The requirement for Navy aircraft to operate and be based on aircraft carriers severely limits the aircraft geometry and penalizes the aircraft weight. It is very difficult for the aircraft designer to develop an aircraft design competitive with its contemporary land based counterparts. Research into methods to expand the design envelope of carrier based aircraft would have significant impact on the combat effectiveness of naval aircraft. Improvements in the carrier elevators, catapult and recovery systems are one obvious means of increasing the capability of aircraft designed for the carriers. Another approach is the use of technology to reduce design margins required to maintain the same or better safety levels. One possible example would be the development of an automated carrier landing system to reduce risk and aircraft loss in carrier landing in all types weather conditions.

## Yaw Thrust Vectoring Nozzle with Augmentation

Each of the configuration concepts utilize a thrust vectoring rotating nozzle to produce yaw/directional control moments. The basic rotating nozzle concept is used in smaller scale on the Pegasus engine in Harrier aircraft. The nozzle is a fixed throat and is actuated at required rates by an air driven motor through a chain drive system.

The application of a rotating nozzle for dedicated yaw control power will require the development of a drive system capable of generating both rate and response appropriate for precise vehicle control requirements. Application of this yaw thrust vectoring concept and mechanization have been explored by The Boeing Company under past proprietary study work and is currently in process of disclosure proceedings for submittal to the U.S. Patent Office.

Integration of a dry power/fixed throat nozzle, although not without risk, is considered to be achievable. However, integration of engine thrust augmentation and providing a functional variable throat rotating exhaust nozzle introduces a challenging high risk element into the system. No prior work has been undertaken to describe the approach or the concept(s) that could be utilized to achieve this capability.

The Air Superiority and Multirole type vehicles sized under this study require augmentation in order to achieve the stipulated performance. The attraction of this nozzle resides in elimination of the vertical/canted tails used in conventional designs, thereby reducing observable signature levels and using direct engine thrust for assured yaw control power throughout the flight envelope.

A potential validation path for developing this concept is shown in Figure 7.0-1. This summary overview addresses both the nozzle and yaw vane concept development, testing and evaluation.

The YF-23 (ATF Prototype) is considered to be a logical flight research candidate aircraft for actual full scale testing and evaluation of the proposed yaw control effector system concept described herein.

Figure 7.0-2 shows how the concept could be employed by modifying the existing aircraft aft fuselage. This application could be a phased program that undertakes the research and development of a dry thrust nozzle initially followed by a parallel effort to produce the augmented engine variable throat nozzle.

The expected results of this research and development would show effective and direct comparisons for observable signature changes when removing canted tails, flying qualities with vectoring in yaw axis, experience with advanced materials application such as Titanium Matrix Composite (TMC) and Advanced Carbon-Carbon (ACC) in the exhaust system, and flight control system limitations with powerful vectoring nozzle integration.

## Flight Research Needs Assessment

### Analysis methods weak

- Conceptual level Products of Inertia
- Determining structural flutter boundaries
- Non-linear aerodynamics
- Engine transient response for bolters and acceleration performance

### Control effectors - Continue quest for new ideas

- Wind Tunnel Database Development      Quantify benefits  
Optimal configurations  
Penalties (blowing)

- Tipperons
- All blowing and suction devices
- Forebody strakes/chimes
- Fluidic thrust vectoring

- Aerodynamics

#### Emperical Methods

- Nonlinear aerodynamics \*update DATCOM)
- Use CFD to develop design methods (base drag)
- Emperically corrected low order panel codes for conceptual design

#### CFD Methods

- Improve transition prediction
- Continue validation of CFD methods
- Improve turn-around and ease of use.

## POTENTIAL YAW THRUST VECTORING RESEARCH PROGRAM

ACTIVITY	Y	1				2				3				4				5			
	Q	1	2	3	4	1	2	3	4	1	2	3	4	1	2	3	4	1	2	3	4

- **Concept/Design Development**
- **Cold Gas Flow T&E**
- **Design Optimization**
- **Hot Gas T & E - FAB, Test & Evaluation**
- **Flight Article**
  - Nozzle system
    - Design
    - Fab. & Assembly
    - Ground testing
  - Air Vehicle
    - Design
    - Fab. & Assembly
    - Nozzle Integration
    - Ground test
    - Flight test

**Assumptions**

- YF-23 Aircraft is obtainable, flyable, and compatible with proposed modification as shown on Fig. 7.0-2

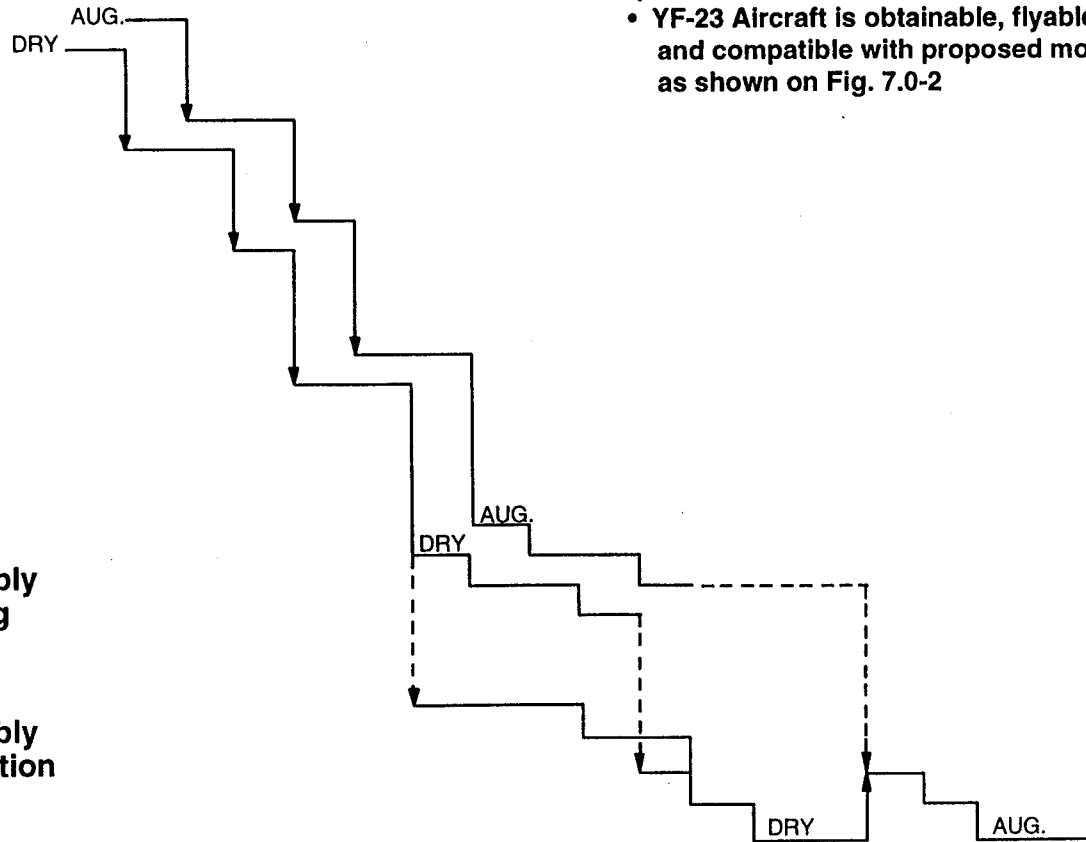



Attributes:

- Airframe in flyable storage (maybe in NASA possession)
- Could modify by replacing aft fuselage that incorporates TVRN (mode of TMC), horizontals in lieu of V-tails, and yaw vane concept

S = 950 ft<sup>2</sup>  
b = 43.604 ft = 523.25 in  
C<sub>r</sub> = 481.2 in  
C<sub>t</sub> = 39.6 in  
λ = 0.08  
AR = 2.0

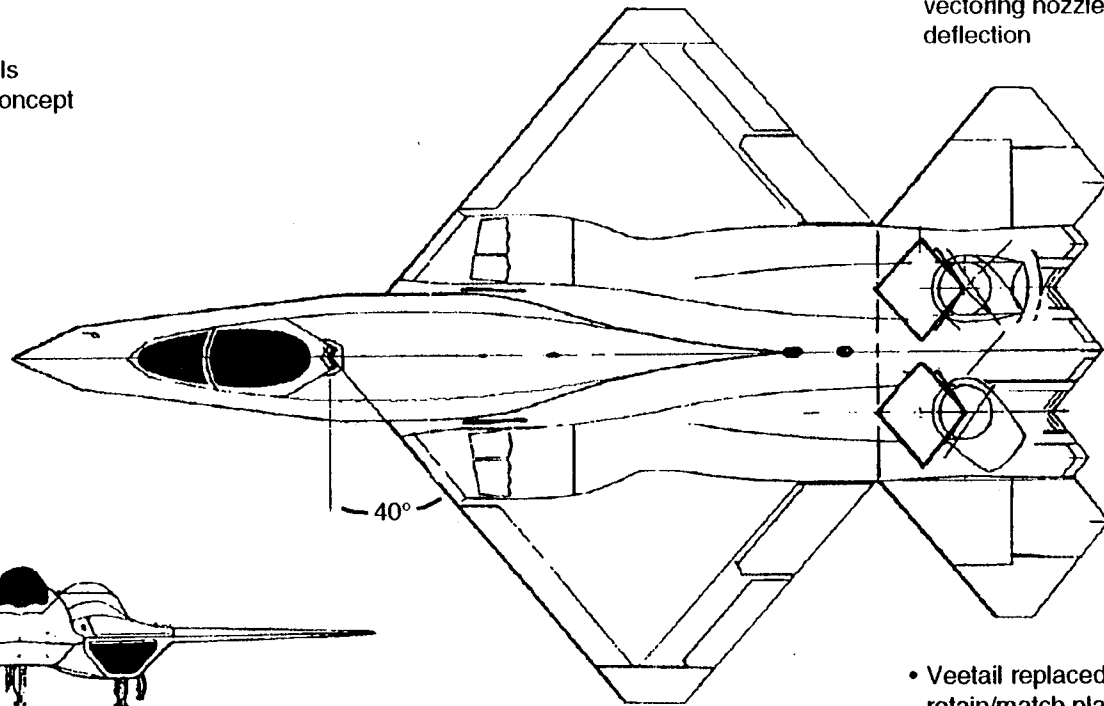

- Incorporate yaw thrust vectoring nozzle ± 45 deg deflection

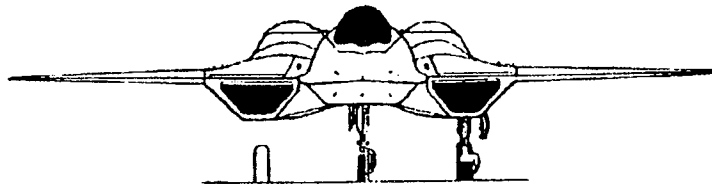

- Veetail replaced by horizontal-retain/match plan view projected area of vector

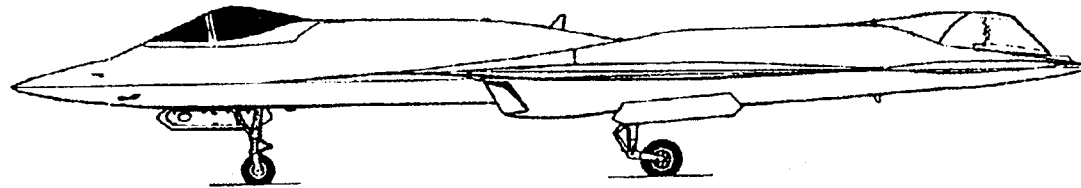

*Yaw Vectoring Concept on YF-23 as Research Article*

REPORT DOCUMENTATION PAGE			Form Approved OMB No. 0704-0188	
Public reporting burden for this collection of information is estimated to average 1 hour per response, including the time for reviewing instructions, searching existing data sources, gathering and maintaining the data needed, and completing and reviewing the collection of information. Send comments regarding this burden estimate or any other aspect of this collection of information, including suggestions for reducing this burden, to Washington Headquarters Services, Directorate for Information Operations and Reports, 1215 Jefferson Davis Highway, Suite 1204, Arlington, VA 22202-4302, and to the Office of Management and Budget, Paperwork Reduction Project (0704-0188), Washington, DC 20503.				
1. AGENCY USE ONLY (Leave blank)	2. REPORT DATE June 1995	3. REPORT TYPE AND DATES COVERED Contractor Report (September 1994)		
4. TITLE AND SUBTITLE Investigation Into the Impact of Agility on Conceptual Fighter Design			5. FUNDING NUMBERS 505-68-70-09 NAS1-18762 Task 22	
6. AUTHOR(S) R. M. Engelbeck				
7. PERFORMING ORGANIZATION NAME(S) AND ADDRESS(ES) Boeing Defense & Space Group Seattle, WA 98124			8. PERFORMING ORGANIZATION REPORT NUMBER	
9. SPONSORING / MONITORING AGENCY NAME(S) AND ADDRESS(ES) National Aeronautics and Space Administration Langley Research Center Hampton, VA 23681-0001			10. SPONSORING / MONITORING AGENCY REPORT NUMBER NASA CR-195079	
11. SUPPLEMENTARY NOTES Contract Technical Monitor: M. J. Logan, NASA Langley Research Center, Hampton, VA 23681-0001				
12a. DISTRIBUTION / AVAILABILITY STATEMENT UNCLASSIFIED - UNLIMITED Subject Category 05			12b. DISTRIBUTION CODE	
13. ABSTRACT (Maximum 200 words) The Agility Design Study was performed by the Boeing Defense and Space Group for the NASA Langley Research Center. The objective of the study was to assess the impact of agility requirements on new fighter configurations. Global trade issues investigated were the level of agility, the mission role of the aircraft (air-to-ground, multi-role, or air-to-air), and whether the customer is Air Force, Navy, or joint service. Mission profiles and design objectives were supplied by NASA. An extensive technology assessment was conducted to establish the available technologies to industry for the aircraft. Conceptual level methodology is presented to assess the five NASA-supplied agility metrics. Twelve configurations were developed to address the global trade issues. Three-view drawings, inboard profiles, and performance estimates were made and are included in the report. A critical assessment and lessons learned from the study are also presented.				
14. SUBJECT TERMS Agility, Fighters, Conceptual Design			15. NUMBER OF PAGES 190	
			16. PRICE CODE A09	
17. SECURITY CLASSIFICATION OF REPORT UNCLASSIFIED	18. SECURITY CLASSIFICATION OF THIS PAGE UNCLASSIFIED	19. SECURITY CLASSIFICATION OF ABSTRACT	20. LIMITATION OF ABSTRACT	

