

## **SHUTTLE LASER ALTIMETER (SLA)**

### **A Pathfinder for Space-Based Laser Altimetry & Lidar**

**Jack Bufton, Bryan Blair, John Cavanaugh, James Garvin,  
David Harding, Dan Hopf, Ken Kirks, David Rabine, & Nita Walsh**

**Laboratory for Terrestrial Physics  
Goddard Space Flight Center  
Greenbelt, MD 20771  
301-286-8671**

### **INTRODUCTION**

The Shuttle Laser Altimeter (SLA) is a Hitchhiker experiment now being integrated for first flight on STS-72 in November 1995. Four Shuttle flights of the SLA are planned at a rate of about a flight every 18 months. They are aimed at the transition of the Goddard Space Flight Center airborne laser altimeter and lidar technology to low Earth orbit as a pathfinder for operational space-based laser remote sensing devices. Future laser altimeter sensors such as the Geoscience Laser Altimeter System (GLAS), an Earth Observing System facility instrument, and the Multi-Beam Laser Altimeter (MBLA), the land and vegetation laser altimeter for the NASA TOPSAT (Topography Satellite) Mission, will utilize systems and approaches being tested with SLA.

The SLA Instrument measures the distance from the Space Shuttle to the Earth's surface by timing the two-way propagation of short ( $\sim 10$  nsec) laser pulses. Laser pulses at 1064 nm wavelength are generated in a laser transmitter and are detected by a telescope equipped with a silicon avalanche photodiode detector. The SLA data system makes the pulse time interval measurement to a precision of about 10 nsec and also records the temporal shape of the laser echo from the Earth's surface for interpretation of surface height distribution within the 100 m diam. sensor footprint. For example, tree height can be determined by measuring the characteristic double-pulse signature that results from a separation in time of laser backscatter from tree canopies and the underlying ground. This is accomplished with a pulse waveform digitizer that samples the detector output with an adjustable resolution of 2 nsec or wider intervals in a 100 sample window centered on the return pulse echo. The digitizer makes the SLA into a high resolution surface lidar sensor. It can also be used for cloud and atmospheric aerosol lidar measurements by lengthening the sampling window and degrading the waveform resolution. Detailed test objectives for the STS-72 mission center on the acquisition of sample data sets for land topography and vegetation height, waveform digitizer performance, and verification of data acquisition algorithms.

The operational concept of SLA is illustrated in Fig. 1 where a series of 100 m footprints stretch in a profile of Earth surface topography along the nadir track of the Space Shuttle. The location of SLA as a dual canister payload on the Hitchhiker Bridge Assembly in Bay 12 of the Space Shuttle Endeavor can also be noted in this figure. Full interpretation of the SLA range measurement data set requires a 1 m knowledge of the Orbiter trajectory and better than  $0.1^\circ$  knowledge of Orbiter pointing angle. These ancillary data sets will be acquired during the STS-72 mission with an on-board Global

positing System (GPS) receiver, K-band range and range-rate tracking of the Orbiter through TDRSS, and use of on-board inertial measurement units and star trackers. Integration and interpretation of all these different data sets as a pathfinder investigation for accurate determination of Earth surface elevation is the overall science goal of the SLA investigation.

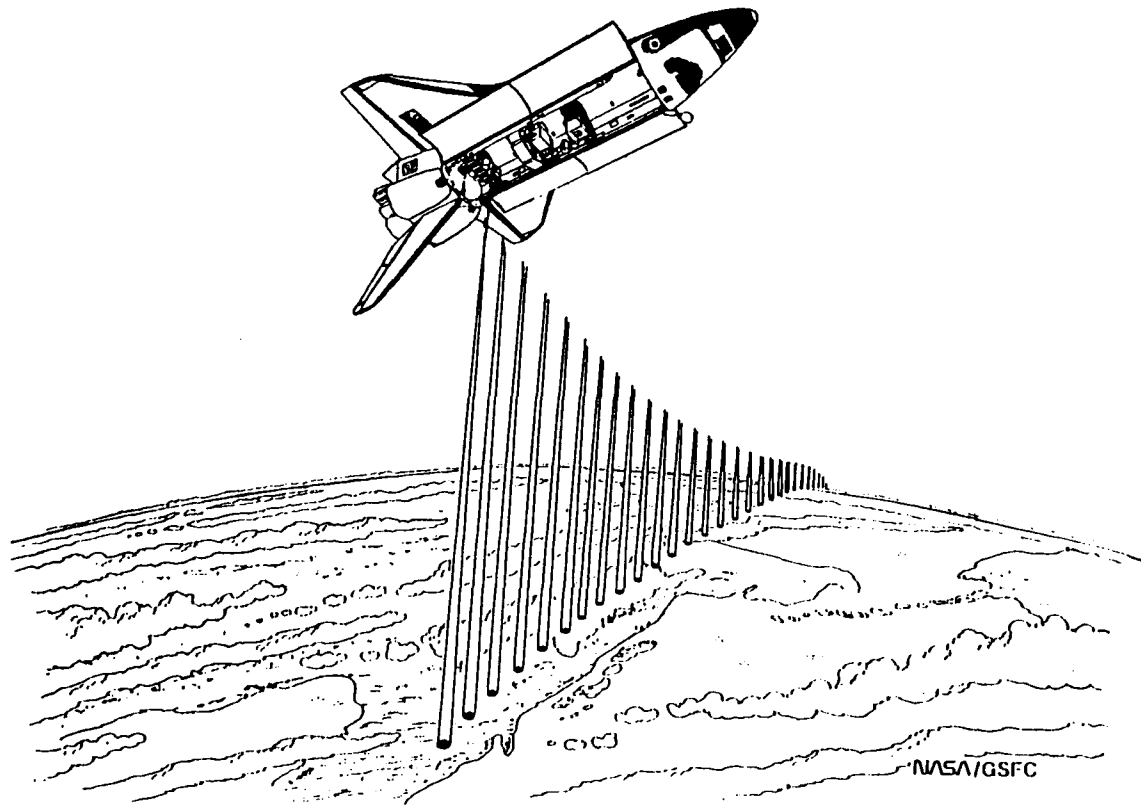

Fig. 1  
Global Topography Measurements with the Shuttle Laser Altimeter

### INSTRUMENT DESCRIPTION

The SLA works by generation of short ( $\sim 10$  nsec duration) laser pulses at a 1064 nm near-infrared wavelength on the Space Shuttle and reception of weak backscattered laser radiation from the Earth. The pulsed laser source is a Nd:YAG device that pulses at a fixed, continuous rate of 10 pps throughout the SLA operational periods. A silicon PIN diode receives  $\sim 1\%$  of the outgoing laser pulse and provides a "START" signal for the pulse timing and data acquisition. In the optically clear atmosphere essentially all the initial laser pulse energy reaches the surface where it is spread into a 100 m diameter spot. Distance between laser spots on the Earth is approximately 740 m due to the laser pulse rate and the Shuttle orbital velocity. Reflection from this spot is typically diffuse which results in spreading of the incident laser light into a full hemisphere. Only a very small fraction of the reflected laser pulse can thus be collected by the SLA receiver telescope back on the Shuttle. The SLA telescope is a gold-plated aluminum, parabolic mirror with a relatively large (for a Hitchhiker canister) 0.38 m diam. aperture. Some twelve orders-of-magnitude separate the received signal (femtojoule) from the initial laser pulse energy ( $\sim 40$  millijoule). A sensitive silicon avalanche photodiode (APD) with 40% quantum efficiency at 1064 nm is used to detect this weak laser pulse at

the telescope mirror prime focus and produce an electronic “STOP” signal. An optical bandpass filter and focusing lenses in the mirror focal plane assist the detector by reducing broadband optical noise due to daytime solar illumination and reduce the size of the image spot to fit it on the 0.8 mm APD.

The SLA Instrument design requires the use of two adjacent, Hitchhiker instrument canisters with nominal 5 ft<sup>3</sup> capacity that are connected by an interconnecting cable for data transmission between the canisters as shown in the general arrangement concept of Fig. 2. The two assemblies are the Laser Altimeter Canister (LAC) and the Altimeter Support Canister (ASC), each of which is separately connected to the Hitchhiker avionics through the signal and power ports. The transmitter and receiver sub-assemblies of the laser altimeter instrument are located in the LAC canister which is equipped with a Hitchhiker motorized door assembly (HMDA) and a 1 inch thick optical window for operation of the laser altimeter instrument in a pressurized environment at the full, clear aperture size of 15.375 inch (0.38 m) diam. Both canisters are pressurized with dry nitrogen; the LAC to 1/2 atmosphere and the ASC to 1 atmosphere. Three-dimensional assembly views of the contents of the two canisters that comprise the SLA are shown in Figs. 3 and 4. Major sub-assemblies of the both canisters are labeled in these drawings.

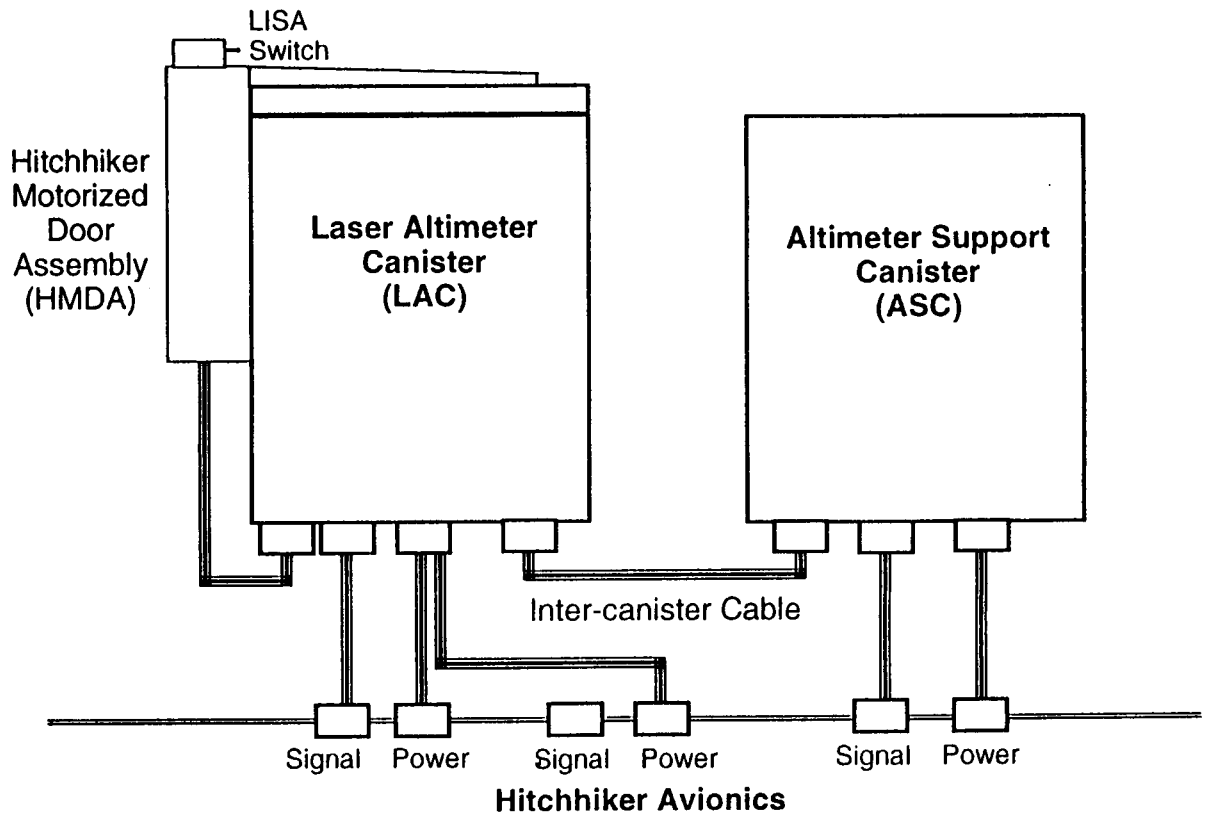

Fig. 2  
Shuttle Laser Altimeter Dual Canister Configuration

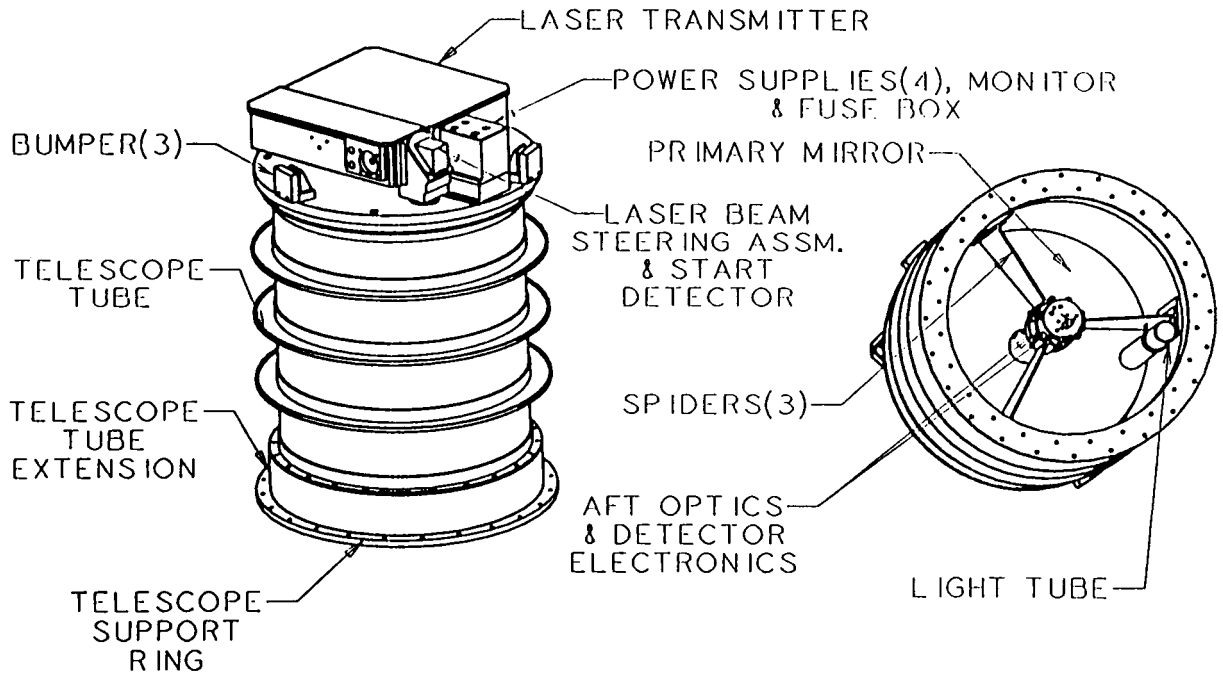

Fig. 3  
Laser Altimeter Canister

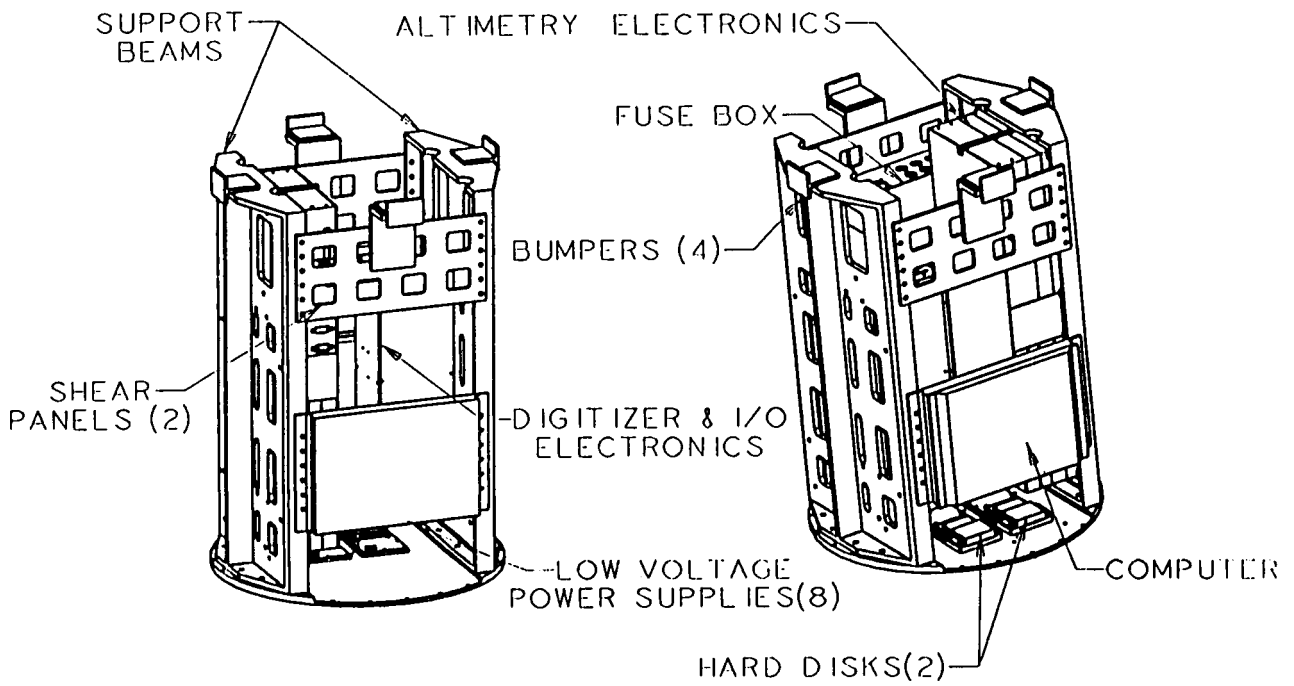

Fig. 4  
Altimeter Support Canister

A functional block diagram of the SLA showing the relationship of the contents of both canisters is presented in Fig. 5. Notable in this figure are the presence of the diode-pumped Nd:YAG laser transmitter in the LAC along with the diamond-turned aluminum parabola telescope mirror and focal plane detector that serve as the optical receiver. The outgoing laser pulse is turned 90° at the output after emerging from the laser source and passes through a Risley prism pair that is adjusted to impart a co-boresight (i.e. alignment) of the laser beam to the fixed pointing (i.e. staring) receiver telescope. The laser source, built by McDonnell Douglas in St. Louis, MO was originally designed for the Mars Observer Laser Altimeter (MOLA) Project. This device weighs only 13 lb. and consumes only 15 W of + 28 vdc electrical power. Power converter and monitor electronics in the LAC serve to provide a source of  $\pm 5$  vdc and  $\pm 12$  vdc for the detector packages. The main APD detector was also originally designed for MOLA Project and was a flight spare.

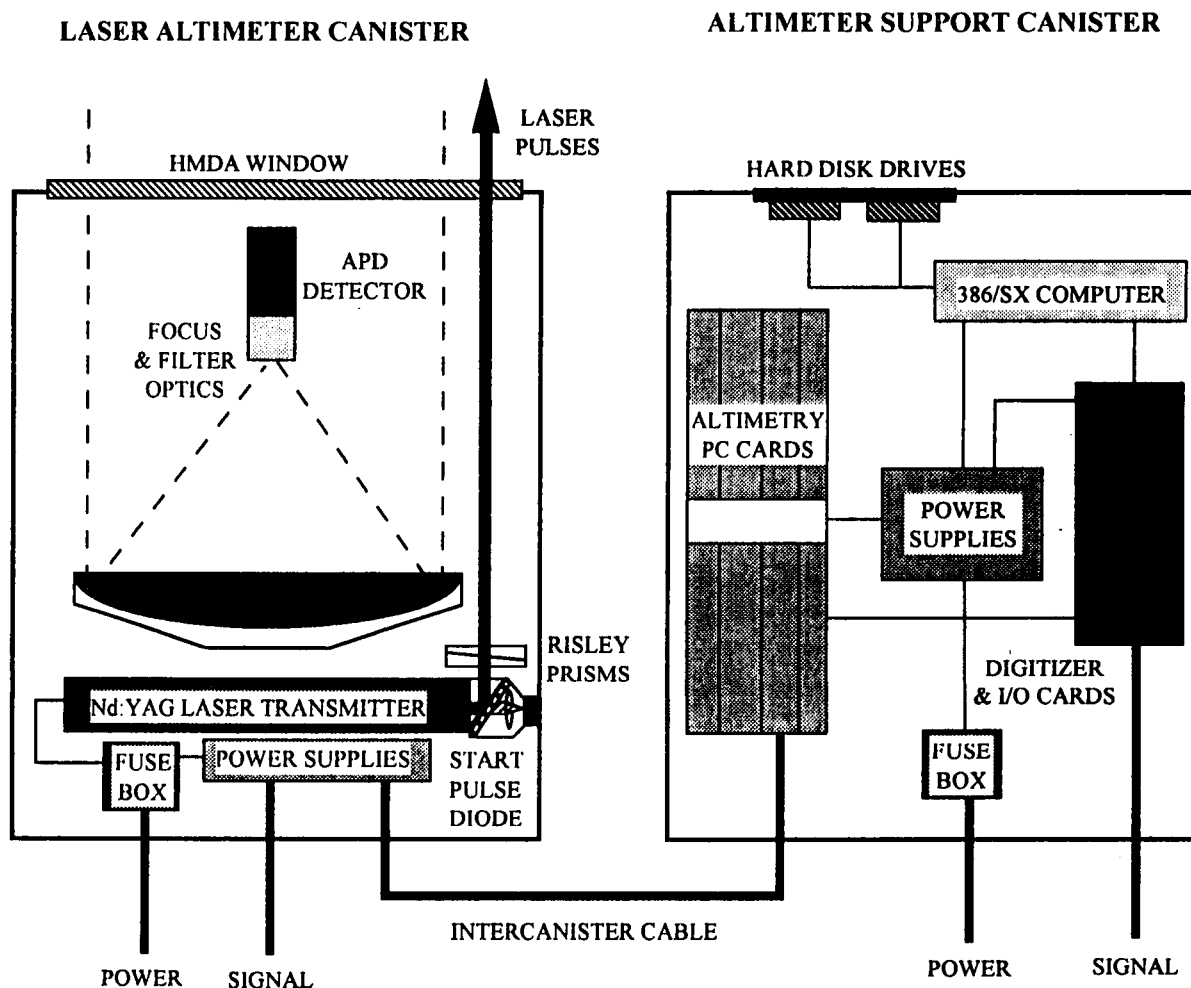

Fig. 5  
Shuttle Laser Altimeter Functional Block Diagram

Principal systems contained in the ASC and their connections are evident in Fig. 5. All the pulse timing, pulse energy, power & temperature monitoring measurements are provided by the altimetry electronics which are composed of five 8x10 inch printed wiring boards and interconnects. These

boards are mounted in aluminum trays or slices that are assembled in an electronics box. Four of these boards were constructed of MIL-SPEC or space-rated EEE parts that were spares from the MOLA Project. Their design is the MOLA design for 4-channel matched-filter laser pulse timing, but does include a clock-pulse interpolation circuit to increase timing resolution to 5 nsec (i.e. provide sub-meter range resolution). Also the fourth (lowest bandwidth) channel of pulse energy is replaced with a channel 1 pulsewidth measurement. Channel 1 has a Gaussian filter detection bandwidth of 16.6 MHz which is signal-to-noise ratio optimized for detection of a 20 nsec pulse. The computer, a 386/SX single board device with a single 512 Kbyte EPROM and 2 Kbyte of RAM, and most low voltage power converters are located in two trays (i.e. slabs) that mount across the support frames of the ASC assembly. The AT computer bus is actually a ribbon cable which extends to an aluminum housing containing the three expander cards necessary for pulse waveform digitization, parallel I/O operations with the altimetry electronics, and the all-important serial I/O communication card extending RS-422 and RS-232 connections to the Hitchhiker avionics for commands and data. The digitizer is capable of 500 Megasample-per-sec (i.e. 2 nsec sample intervals) operation and has an on-board memory of 8 K samples. It is potentially a very power hungry device that would like to use 25 W or more when operating continuously. A key innovation of the SLA Instrument design is power cycling of this device that turns in on for only 5 msec when it is needed, i.e. when the laser pulse is transmitted, flies to Earth, returns and is analyzed. The digitizer duty cycle is thus 5% (5 msec every 100 msec based on the 10 pps laser pulse rate). Separate dc-to-dc converters supply the +5 vdc and +12 vdc required by the three expander cards and are mounted inside the card housing. A summary of the mass and power parameters for the both canisters is given in Table 1.

| PAYLOAD ASSEMBLY                           | MASS (KG) | MASS (LB) | POWER AVERAGE (W) | HEATER POWER (W) | PEAK POWER (W) | ENERGY AVERAGE* (KWH/DAY) |
|--------------------------------------------|-----------|-----------|-------------------|------------------|----------------|---------------------------|
| LASER ALTIMETER CANISTER (instrument)      | 48        | 105.7     | 20                | 60               | 90             | 0.6                       |
| HMDA CANISTER/ with WINDOW                 | 117.3     | 258.3     | -                 | -                |                | -                         |
| SUB-TOTAL (LAC):                           | 165.3     | 364       | 20                | 60               | 90             | 0.6                       |
| ALTIMETER SUPPORT CANISTER (instrument)    | 51.1      | 99.9      | 34                | 60               | 105            | 0.77                      |
| STANDARD HITCHHIKER CANISTER (5 cubic ft.) | 45.4      | 153.8     | -                 | -                |                | -                         |
| SUB-TOTAL (ASC):                           | 96.5      | 253.6     | 34                | 60               | 105            | 0.77                      |
| HITCHHIKER AVIONICS & ADAPTER PLATE (1/3)  | 27.7      | 61        | 42                | 0                |                | 1.01                      |
| TOTAL (SLA):                               | 289.5     | 678.6     | 96                | 120              | 195            | 2.38                      |

Table 1  
Mass and power summary for the Shuttle Laser Altimeter Instrument.

\* Assumes: 50% operations duty cycle & replacement heaters to maintain LAC & ASC at minimum operating temp.

The LAC and ASC canister electronics are connected by a special purpose cable that is separate from the Hitchhiker power and signal interface cables. This multi-conductor (41) interconnecting cable contains coaxial cables for transfer of data pulses from the LAC to the ASC, #22 AWG twisted pair wires for connection of the various temperature sensor lines and digital I/O lines from the LAC to the ASC, and transmission of the TTL laser fire pulses from the ASC to the LAC.

## **HITCHHIKER PAYLOAD OPERATIONS**

An initial on-orbit cool-down period of a minimum of 24 hrs. prior to SLA activation is planned in order to achieve optimum operation (the generation of maximum laser pulse energy) of the laser altimeter transmitter in the LAC at 0 C. During this period thermostatically-controlled replacement heaters will activate if the LAC falls below -5 C or the ASC falls below +5 C. The first step in activation of the SLA occurs when astronauts activate the laser power enabling Standard Switch Panel (SSP) switches S16 & S22 and the Hitchhiker motorized door assembly (HMDA) for the Laser Altimeter Canister is opened by ground control. With an open door and acceptable operating temperatures in both the LAC and the ASC, the power-on command will be given to the ASC in order to initiate SLA operation for a verification of medium and low rate telemetry and commanding capability. Activation of the LAC canister shall be permitted only when the Orbiter is in the -ZLV orientation, SLA instrument power is on, and the HMDA door lid is fully open. Laser transmitter operation shall not be permitted during crew EVA or any spacecraft retrieval operations. The potential eye safety hazard to the crew from reflection of SLA laser radiation; either from a partially open HMDA door lid or objects in the near-space environment of the Orbiter will be controlled by three independent inhibits to SLA laser operation. These are as follows:

- (1) a relay in the LAC that switches +28 vdc electrical input power to the laser;
- (2) a relay in the LAC that switches the +28 vdc return of electrical power to the laser; and
- (3) ground commanding through the ACCESS computer.

Inhibits (1) and (2) are respectively controlled by astronaut activated switches S22 and S16. A door interlock switch, called the LISA switch, is in series with inhibit (2) and prevents laser operation until the door is fully open (95° rotation). Computer commands from the Hitchhiker Payload Operations Control Center (POCC) are required to operate the HMDA door, activate the ASC and LAC, and generate laser fire pulses from the ASC which go by intercanister cable to the LAC and its laser transmitter.

The data acquisition configuration of SLA Instrument operations is controlled by several commands and 38 individual parameters that can be updated through the parameter command. The SLA data system command instructions flow to the SLA on-board 386/SX computer where they modify the pre-programmed EPROM flight software operational modes and default parameter values. When first activated, the on-board SLA computer boots from the EPROM and enters the flight software in a "SAFE" (i.e. standby) mode in which both medium-rate and low-rate telemetry packets are generated, but no laser pulses are generated. Upon receipt of the "FIRE" command, the laser transmitter pulses at 10 pulses per sec, pulse data from laser radiation backscattered by the Earth's surface are collected and processed, and the altimetry and housekeeping data are formatted and recorded on-board on hard disk drives and sent by both telemetry channels to the ground for SLA GSE monitoring and recording. All laser altimeter data are acquired and stored on the twin 260 Mbyte hard disk drives in the ASC and a summary of laser altimeter ranging, waveform, and housekeeping data are sent over the HH 1200 baud low-rate telemetry channel. The flight hard drives are VIPER™ drives manufactured by Integral, Inc. and have excellent shock/vibrations specifications

(150 G operating, 750 G non-operating). The complete data set is continuously sent to the HH medium-rate data channel at 19.2 Kbaud and reaches the ground when that link is available. The ASC computer program operates the laser altimeter instrument in the LAC continuously until the "SAFE" (i.e. laser off) command is issued. The SLA payload operations will typically continue for 10 to 15 hours, nominally centered on the crew sleep periods after mission day 2. The total planned data take for STS-72 is about 100 hours. The minimum operational cycle length requested is two orbits (about 3 hours). After laser transmitter operation is secured and SLA payload power is removed, the HMDA door on the LAC is closed to complete payload operations.

Pointing control for SLA is required to be within  $\pm 5^\circ$  (3 sigma in roll & pitch) with respect to the Orbiter local nadir (-ZLV) for successful payload operation. The Flight Plan for STS-72 indicates a nominal pointing control deadband of  $1^\circ$  supplemented by two observational periods later in the Mission with  $0.1^\circ$  pointing control deadband. This high-quality pointing control will permit collection of SLA data at the Orbiter nadir direction resulting in minimized laser pulse spreading due to off-axis pointing effects. Data quality for the SLA Experiment is also highly dependent on nominal (full power) operation of the pulsed laser transmitter and maintenance of a clear, unobstructed line-of-sight for the SLA telescope aperture. In the hazy or cloudy atmospheres the laser pulse is scattered before reaching the Earth's surface and the laser altimeter measurement may be triggered by the top surface of the cloud, haze, or aerosol layer. Actual operations of the SLA in space will encounter a continuum of atmospheric conditions ranging from the extremes of cloudy to clear providing a good operational test for the laser altimetry technique. Not only do these conditions impart a great variability on the amplitude of the received laser pulse but result in a highly variable solar backscatter "noise" component. The SLA data acquisition algorithm can accommodate a variable noise level by an automatic threshold tracking loop. In this loop the continuous monitoring of APD detector noise level in a noise pulse counter is used to adjust a voltage threshold up or down to "track" the once-per-sec noise count. This loop provides a stable false-alarm-pulse-rate and maximizes the probability-of-detection of the weak laser pulses that are returned from the surface; hence maximizing the Earth surface data. Performance of this loop in space is a key engineering objective of the STS-72 Mission opportunity for SLA.

## **ACKNOWLEDGMENTS**

In addition to all the many long hours contributed by each of the named co-authors, we wish to recognize the contributions of many individuals in the Experimental Instrumentation Branch, the Laboratory for Terrestrial Physics, the Earth Sciences Directorate, the Engineering Directorate at the GSFC, and the Observational Sciences Branch at the Wallops Flight Facility (WFF) for their many contributions over the years to the development, testing, and delivery of the Shuttle Laser Altimeter Instrument. Notable among these is work by Paul Weir (retired), Bill Schaefer, James Fitzgerald, James C. Smith, Glenn Staley (retired), and Dick Aldridge at the GSFC and Gerry McIntire at the WFF. Special thanks to Vernon Muffaletto (now deceased; Muffaletto Optics, Baltimore, MD) and Bill Clark (Optical Filter Crop., Keene New Hampshire) for the SLA telescope and Greg Speno, Steve Monroe, Gary Gaither and the rest of the laser development team at McDonnell Douglas in St. Louis for the SLA laser transmitter and the APD detector hybrid. Finally, this effort could not have been possible without the foresight of Henry Price (former Chief Engineer at the GSFC), funding by the GSFC Director's Discretionary Fund, and by all the altimetry and detector electronics design, spare parts, algorithms, experience, and continued support provided by the Mars Observer Laser Altimeter Team at the GSFC.