

NASA Technical Memorandum 107027

Development of a 1 kW, 200°C Mapham Inverter

Ahmad Hammoud and Scott Gerber
NYMA, Inc.
Brook Park, Ohio

Eric Baumann, Eric Overton, Ira Myers, and Robert Bercaw
Lewis Research Center
Cleveland, Ohio

Prepared for
Power Conversion and Intelligent Motion/Power Quality '95
sponsored by Intertec International, Inc.
Long Beach, California, September 10–15, 1995



National Aeronautics and
Space Administration

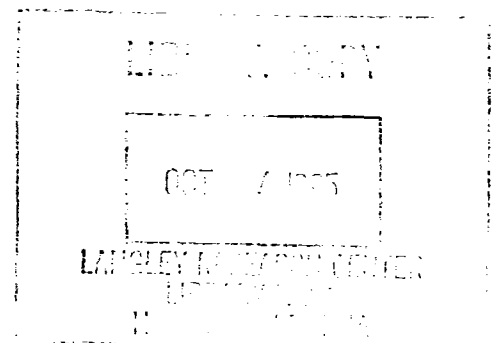





3 1176 01422 9323

DEVELOPMENT OF A 1 kW, 200°C MAPHAM INVERTER

Ahmad Hammoud, Scott Gerber
NYMA, Inc.
NASA Lewis Research Group
Cleveland, OH 44135

Eric Baumann, Eric Overton,
Ira Myers and Robert Bercaw
NASA Lewis Research Center
Cleveland, OH 44135

ABSTRACT

Electronic systems and components are often exposed to high temperature environment in space-based applications, nuclear power facilities, and geothermal energy extraction fields. A key requirement for these systems is, therefore, to withstand the high temperature exposure while maintaining efficient and reliable operation. Efforts were taken to design and develop a high temperature power inverter capable of 200°C operation. In this work, a 1 kW, 20 kHz Mapham inverter was designed and evaluated as a function of temperature at different load levels. The inverter system, excluding its input, control and logic circuitries, was characterized at temperatures from ambient to 200°C at 0%, 50%, and 100% resistive loading. With an applied input voltage of 75 VDC, the inverter produced an output of 250 VAC. The results obtained, which have indicated good operational characteristics of the inverter up to 200°C, are presented and discussed.

INTRODUCTION

Future challenges of advanced power systems comprise increasing packaging density, improving reliability, and surviving hostile environment. High temperature constitutes one of the harsh stresses where power systems and components will be exposed to during their lifetime. These applications include deep space exploration, communications satellites, and supersonic transport vehicles. Others include engine and brake-mounted sensors and electronics in the auto industry, and control and instrumentation in well logging fields. For space-based applications, there is an enormous demand for increasing the energy densities and raising the power levels of the power systems and associated components with the objectives to reduce size and weight, and to further improve efficiency and reliability. These requirements, however, will certainly result in raising the operating temperature of the power system and will create, among other things, thermal stresses that well exceed the withstanding or normal operating level of the presently available devices and components. Improvement in the current designs and processes, and the identification of new

materials and components capable of providing reliable and efficient operation at high temperature, thus, play important role for future needs of space power systems to be met. In addition to meeting the requirements of hostile environment survivability and endurance, other benefits that can be gained from the availability of reliable components and systems with high temperature capability include reduced launch cost, simplified system design, and improved thermal management. It has been reported, for example, that high temperature components can make significant improvement in reliability for satellite mission on the order of a hundred years [1].

A program to develop lightweight, reliable 200°C power inverter for aerospace applications is being performed at NASA Lewis Research Center. As part of this effort, an existing 1 kW Mapham inverter designed to operate at room temperature was modified to investigate potential 200°C operation. Modification of the system included circuit design and the utilization of in-house developed high temperature components. The inverter was characterized at high temperature from ambient to 200°C at 0%, 50%, and 100% resistive loading. In this paper, the experimental procedure and the results obtained are discussed.

EXPERIMENTAL PROCEDURE

As was mentioned earlier, an existing power inverter designed for room temperature operation was modified in order to explore high temperature capability. The original inverter is generally known as a Mapham inverter capable of providing 1 kW with a 125 VDC input. It uses a resonant tank circuit in an H-bridge configuration to develop a sinusoidal voltage across the resonant capacitor with a fundamental output frequency of 20 kHz [2]. Modification of the inverter included circuit reconfiguration and utilization of high temperature power components that were developed either in-house or through collaborative research efforts [3-5]. The basic circuit diagram of the inverter is shown in Figure 1 with the dashed block representing the section which was exposed and thus evaluated at high temperatures. A list of the high temperature components used is given in Table 1 [3-5].

Evaluation of the inverter was performed at high temperature with various load levels. A bias of 75 VDC was supplied to the input stage of the inverter which resulted in an output voltage of 250 VAC at about 20 kHz. A Hewlett-Packard Model 4030A power supply was used for the input while Systron Donner TL8-3 furnished power for the control logic. A hotpack oven was used as the heating chamber and thermocouples were mounted on the individual switches, inductors, capacitors, and on the center and end of the coaxial transformer using a Duralco 4525 epoxy. The temperatures of the chamber and the components were monitored by a Keithley 740 System Scanning Thermometer and a Doric Trendicator. At a given load level, the inverter circuit was characterized as a function of temperature from ambient to 200°C in 25°C increments. A soak period

of 30 minutes was allowed at each test temperature to allow thermal stabilization. The temperature rise and variations of the various components were recorded. In addition, the values and the waveforms of many monitored signals were obtained using Tektronix DSA 602A Waveform Analyzer. The measured signals included the voltages and currents of the input source, switches, inductors, capacitors, and the transformer primary and secondary windings. Besides the high temperature characterization, the effect of loading on the measured properties was also determined as the inverter was subjected to 0% (open-circuit secondary), 50% (145 Ω), and 100% (72 Ω) resistive loading at a given test temperature.

RESULTS AND DISCUSSIONS

The operational characteristics of the inverter were investigated by monitoring and recording the temperature variation of the inverter components as well as the current and voltage levels and waveforms of several variables. During the course of testing, however, there was little deviation in the operation of the inverter and insignificant change in many of its measured parameters whether by applying different test temperature or changing the load level. Therefore, only selected data will be presented.

The switch and output capacitor current and voltage waveforms with no load applied at 25°C and 200°C are shown in Figures 2 and 3, respectively. These waveforms are also shown in Figures 4 and 5 with 100% resistive load connected to the inverter output. It can be clearly seen that no major variations were exhibited by these parameters due to change in test temperature or load level. For both cases, no load and full load conditions, it should be pointed out, however, that slight increase in the switch (IGBT-diode) voltage turn-off overshoot occurs as the test temperature was increased to 200°C. It is believed that this overshoot is most likely due to the increase in diode reverse recovery time with temperature [5]. Initially, 150°C rated diodes were used but they failed to operate for any significant time at 200°C. These diodes were then replaced by 175°C rated units and, as a result, extended operation at 200°C was achieved.

Figure 6 depicts the difference between the case temperature of one of the inductors and that of the chamber as a function of chamber temperature for three load levels. At a given test temperature, the inductor case temperature had an average of 20° ΔT higher than that of the test chamber. Similar trend was observed for all inductors. Unlike the inductors, the ΔT in the case temperature of the switches amounted only to about 15°C, as shown in Figure 7. It is important to note that the higher ΔT experienced by the inductors was due to the fact that the thermocouple mounted on the inductor winding was wrapped with teflon tape for mechanical support. This insulation layer might have affected thermal distribution and interfacial equilibrium.

CONCLUSIONS

Key design requirements for advanced spacebased power systems include higher energy densities, larger power levels, and better harsh environment survivability. The development of high temperature components is therefore necessary to meet these goals and to further improve on the mission's thermal management design, durability and cost effectiveness. In this work, a 1 kW Mapham inverter utilizing some high temperature components as its output and switching stages was evaluated at three load levels in the temperature range of room to 200°C. The preliminary results indicate that the power inverter operated successfully over the entire temperature range and at various load levels without any noticeable change in its characteristic behavior. In fact, the inverter showed good stability in its overall performance although some of the individual components exhibited slight variation in their properties with temperature. Although the present work demonstrated 200°C operation of the power inverter, more testing is required to fully characterize the reliability of the system and to determine its potential for long term use in high temperature environments.

ACKNOWLEDGEMENTS

This work was supported by NASA Lewis Research Center, Contract #NAS3-27186, Task Order #5430-04, "High Temperature Power Electronics."

REFERENCES

- [1] J. Burnham, "Leakage Current-Voltage Characteristics of Solid Tantalum Capacitors at Very High Temperatures," Proceedings of the 24th Electronic Components Conference, Washington, DC, May 13-15, 1974.
- [2] E. D. Baumann, I. T. Myers, and A. N. Hammoud, "Electrical Characterization of a Mapham Inverter Using Pulse Testing Techniques," 25th Intersociety Energy Conversion Engineering Conference, Reno, Nevada, August 12-17, 1990.
- [3] A. N. Hammoud, E. D. Baumann, I. T. Myers, and E. Overton, "High Temperature Power Electronics Program," NASA LeRC Internal Program Review, November 1993.
- [4] D. M. Divan, D. W. Novotny, and N. H. Kutkut, "High Temperature Co-axial Winding Transformers," University of Wisconsin, Wisconsin Power Electronics Research Center, Interim Report, February 1993.
- [5] J. Bromstead, B. Weir, R. M. Nelms, R. W. Johnson, and R. Askey, "Silicon Device Performance Measurements to Support Temperature Range Enhancement," Auburn university - CCDSF, Final Report, January 1994.

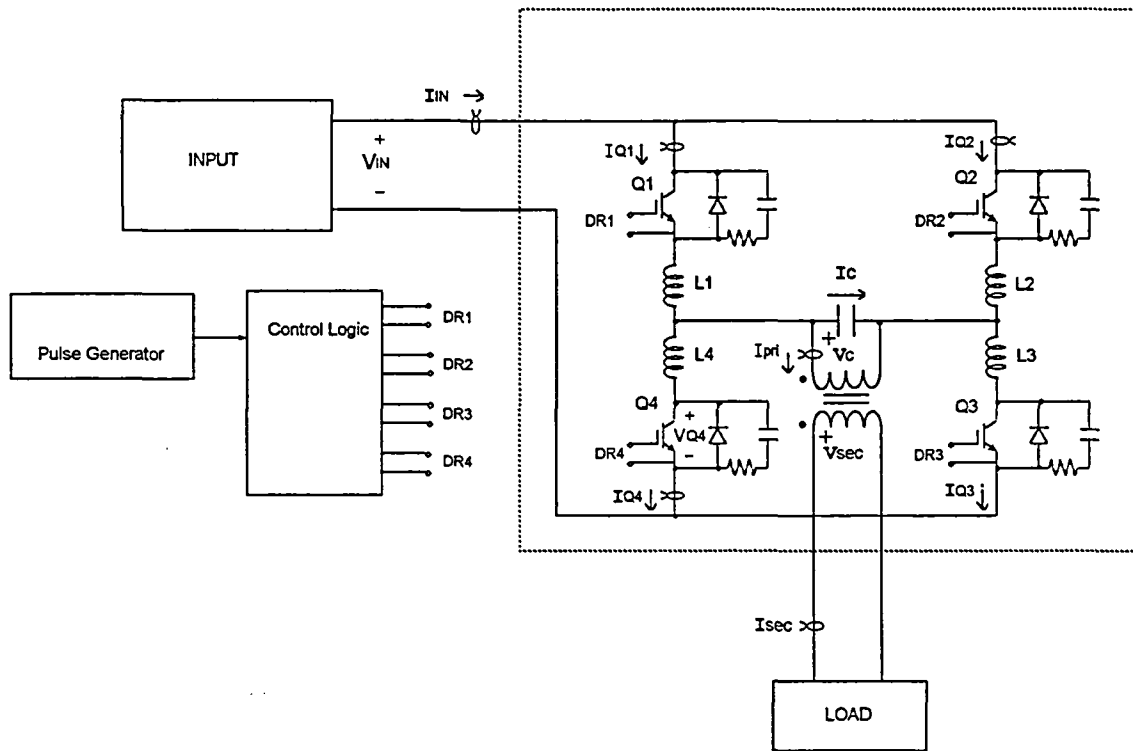

Figure 1. Basic circuit of the Mapham Inverter

Table 1. High Temperature Components Specifications [3-5].

Component	Specification
Capacitor	Capacitance: 1.0 μ F Voltage: 125 VAC Frequency: 20 kHz Dielectric: film
Inductor	Inductance: 13 μ H Core: MPP Frequency: 20 kHz Current: 25 A
Transformer	Power: 2.5 kVA Voltage: 125/250 VAC Frequency: 20 kHz Core: 80% Nickel tape
Switch	Device: IGBT TA9796 Voltage: 1000 V Current: 34 A

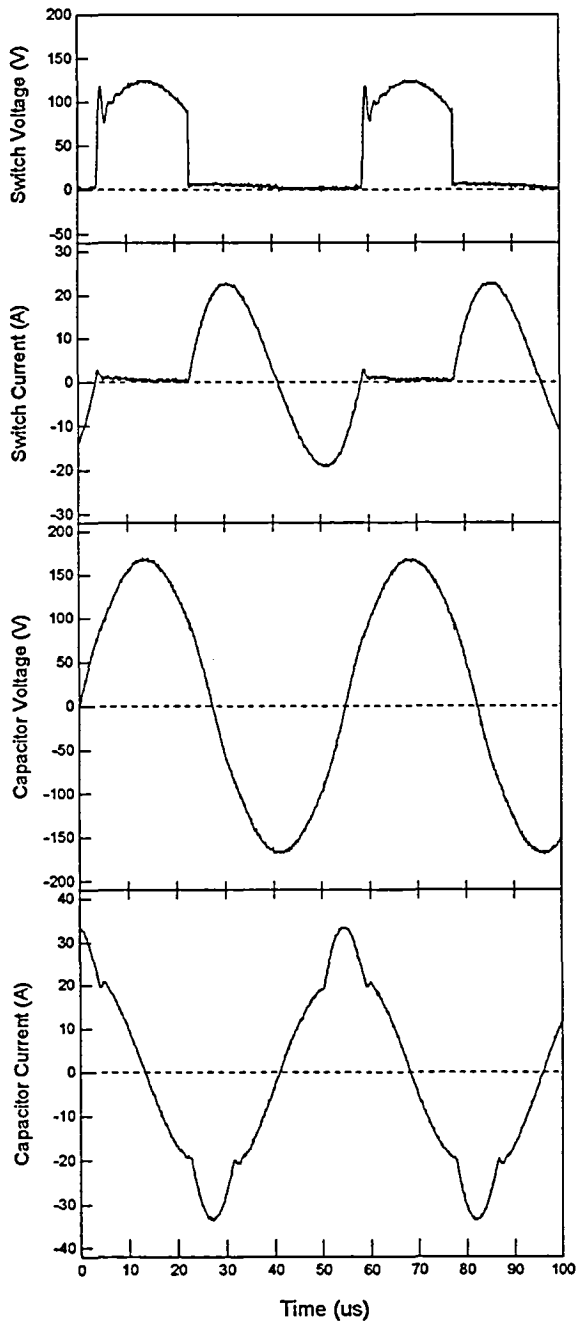

Figure 2: Switch (Q4) and output capacitor currents and voltages with no load at 25°C.

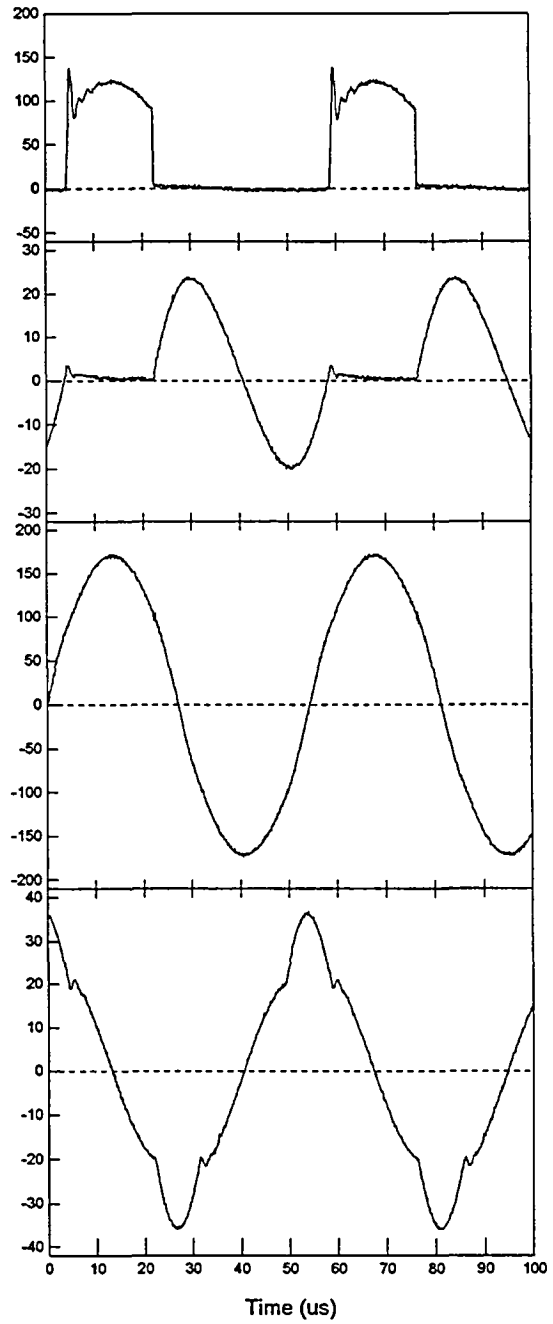

Figure 3: Switch (Q4) and output capacitor currents and voltages with no load at 200°C.

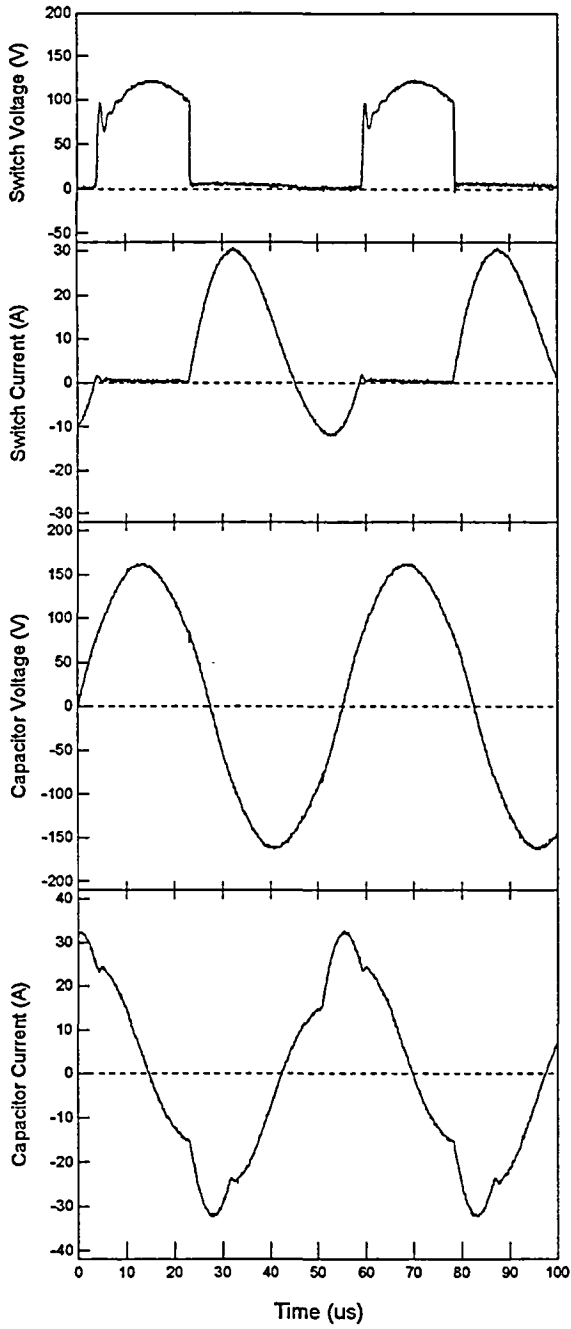

Figure 4: Switch (Q4) and output capacitor currents and voltages with full load at 25°C.

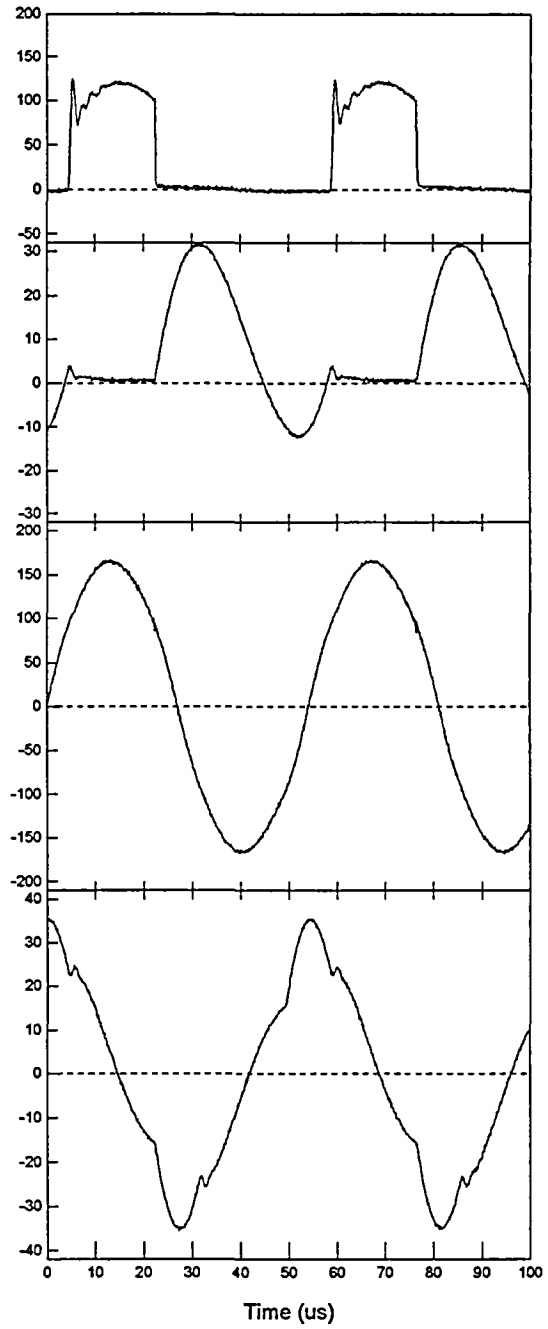

Figure 5: Switch (Q4) and output capacitor currents and voltages with full load at 200°C.

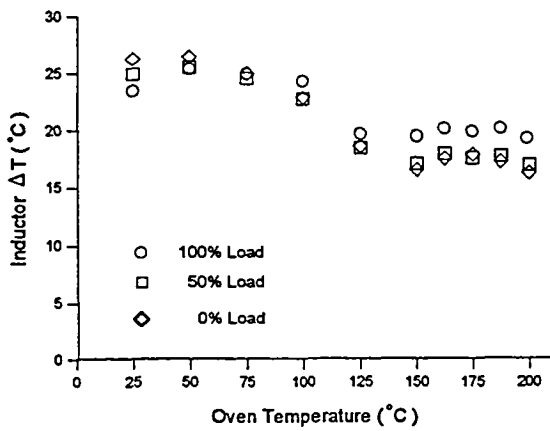

Figure 6: Inductor temperature rise above that of the chamber at various loads.

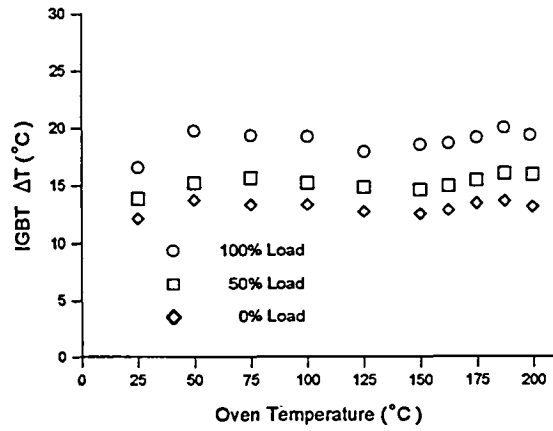
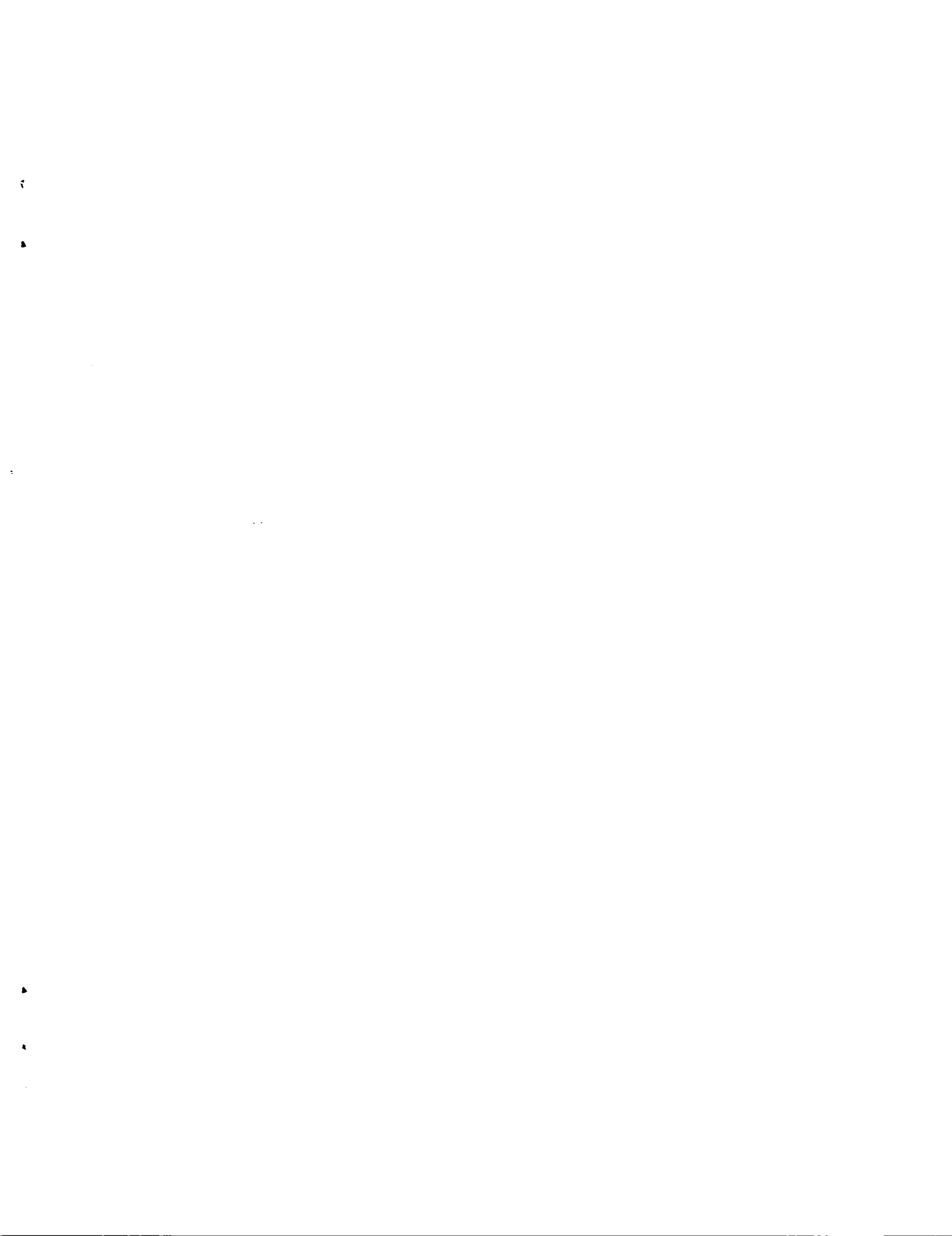

Figure 7: Switch temperature rise above that of the chamber at various loads.



REPORT DOCUMENTATION PAGE

Form Approved
OMB No. 0704-0188

Public reporting burden for this collection of information is estimated to average 1 hour per response, including the time for reviewing instructions, searching existing data sources, gathering and maintaining the data needed, and completing and reviewing the collection of information. Send comments regarding this burden estimate or any other aspect of this collection of information, including suggestions for reducing this burden, to Washington Headquarters Services, Directorate for Information Operations and Reports, 1215 Jefferson Davis Highway, Suite 1204, Arlington, VA 22202-4302, and to the Office of Management and Budget, Paperwork Reduction Project (0704-0188), Washington, DC 20503.

1. AGENCY USE ONLY (Leave blank)	2. REPORT DATE August 1995	3. REPORT TYPE AND DATES COVERED Technical Memorandum	
4. TITLE AND SUBTITLE Development of a 1 kW, 200°C Mapham Inverter		5. FUNDING NUMBERS WU-233-01-0C	
6. AUTHOR(S) Ahmad Hammoud, Scott Gerber, Eric Baumann, Eric Overton, Ira Myers, and Robert Bercaw		8. PERFORMING ORGANIZATION REPORT NUMBER E-9843	
7. PERFORMING ORGANIZATION NAME(S) AND ADDRESS(ES) National Aeronautics and Space Administration Lewis Research Center Cleveland, Ohio 44135-3191		10. SPONSORING/MONITORING AGENCY REPORT NUMBER NASA TM-107027	
9. SPONSORING/MONITORING AGENCY NAME(S) AND ADDRESS(ES) National Aeronautics and Space Administration Washington, D.C. 20546-0001		11. SUPPLEMENTARY NOTES Prepared for Power Conversion and Intelligent Motion/Power Quality '95 sponsored by Intertec International, Inc., Long Beach, California, September 10-15, 1995. Ahmad Hammoud and Scott Gerber, NYMA, Inc., 2001 Aerospace Parkway, Brook Park, Ohio 44142 (work funded by NASA Contract NAS3-27186); Eric Baumann, Eric Overton, Ira Myers, and Robert Bercaw, NASA Lewis Research Center. Responsible person, Eric Overton, organization code 5430, (216) 433-8189.	
12a. DISTRIBUTION/AVAILABILITY STATEMENT Unclassified - Unlimited Subject Category 33 This publication is available from the NASA Center for Aerospace Information, (301) 621-0390.		12b. DISTRIBUTION CODE	
13. ABSTRACT (Maximum 200 words) Electronic systems and components are often exposed to high temperature environment in space-based applications, nuclear power facilities, and geothermal energy extraction fields. A key requirement for these systems is, therefore, to withstand the high temperature exposure while maintaining efficient and reliable operation. Efforts were taken to design and develop a high temperature power inverter capable of 200°C operation. In this work, a 1 kW, 20 kHz Mapham inverter was designed and evaluated as a function of temperature at different load levels. The inverter system, excluding its input, control and logic circuitries, was characterized at temperatures from ambient to 200°C at 0%, 50%, and 100% resistive loading. With an applied input voltage of 75 VDC, the inverter produced an output of 250 VAC. The results obtained, which have indicated good operational characteristics of the inverter up to 200°C, are presented and discussed.			
14. SUBJECT TERMS High temperature; Inverter; Power components		15. NUMBER OF PAGES 10	
17. SECURITY CLASSIFICATION OF REPORT Unclassified		16. PRICE CODE A02	
18. SECURITY CLASSIFICATION OF THIS PAGE Unclassified	19. SECURITY CLASSIFICATION OF ABSTRACT Unclassified	20. LIMITATION OF ABSTRACT	

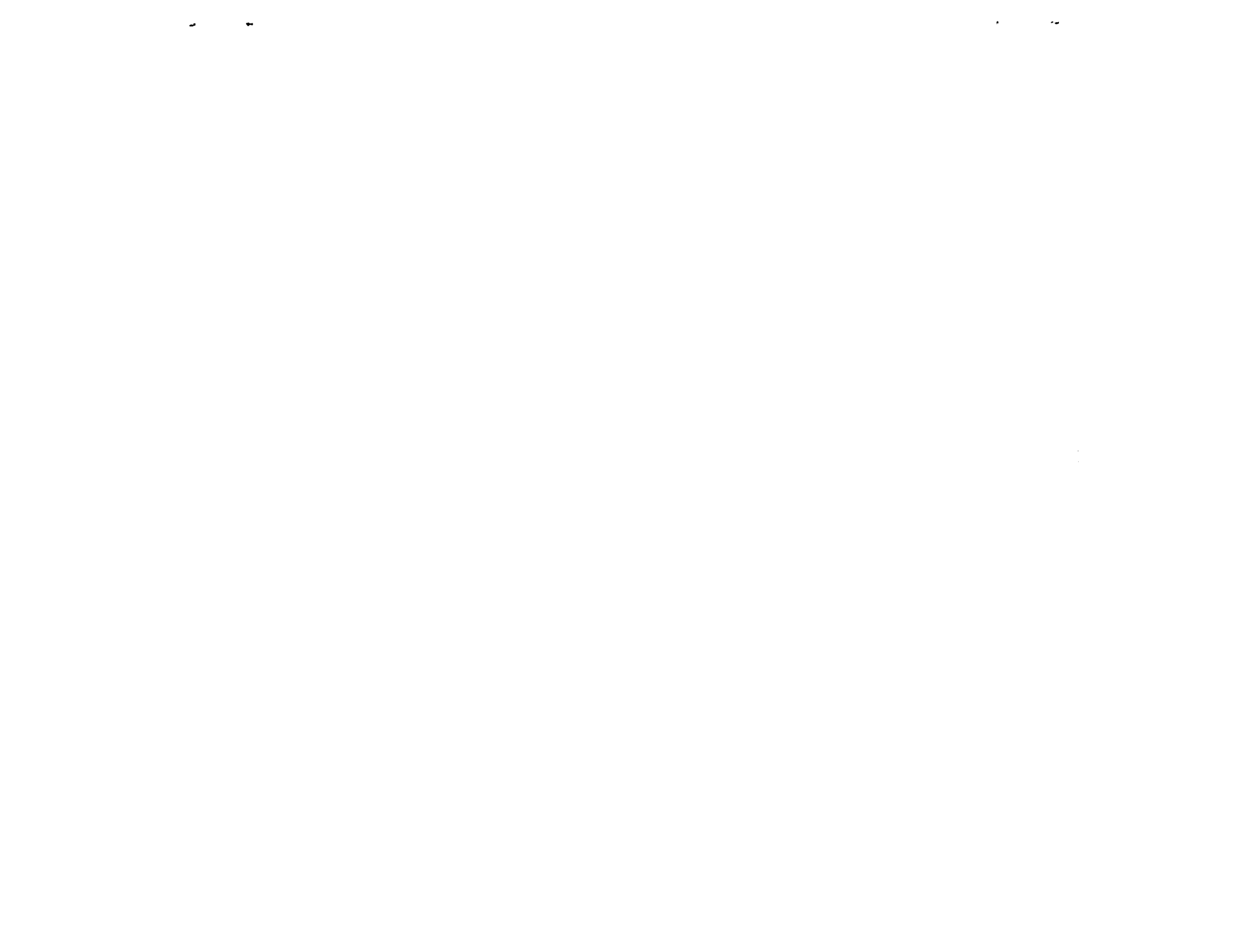

National Aeronautics and
Space Administration
Lewis Research Center
21000 Brookpark Rd.
Cleveland, OH 44135-3191

Official Business
Penalty for Private Use \$300

POSTMASTER: If Undeliverable — Do Not Return

