Piloted Simulation Tests of Propulsion Control as Backup to Loss of Primary Flight Controls for a Mid-Size Jet Transport

John Bull, CAELUM Research Corporation, Mountain View, California

Robert Mah, Gloria Davis, Joe Conley, and Gordon Hardy, Ames Research Center, Moffett Field, California

Jim Gibson, Recom Technologies, Inc., San Jose, California

Matthew Blake, Ames Research Center, Moffett Field, California

Don Bryant and Diane Williams, ManTech/NSI Technology Services Corporation, Sunnyvale, California

December 1995



National Aeronautics and
Space Administration

Ames Research Center
Moffett Field, California 94035-1000

TABLE OF CONTENTS

	Page
Summary	1
1 Introduction.....	1
1.1 Purpose of Each Series of Piloted Simulation Tests.....	2
2 Simulation Aircraft Description	2
2.1 ACFS Facility Description.....	2
2.2 ACFS Aircraft Physical Dimensions	2
2.3 ACFS Aircraft Flight Dynamics.....	2
2.4 ACFS Turbulence Model.....	3
3 PCA Concept And Control Laws	3
3.1 PCA Typical Step Response Time Histories	3
3.2 PCA Industry Benefits.....	3
4 Pilot Interface Tests (June 1992).....	6
4.1 Pilot Interface Test Objectives.....	6
4.2 Pilot Interface Test PCA Modes	6
4.3 Pilot Interface Test Displays.....	6
4.4 Pilot Interface Test Description	6
4.5 Pilot Interface Test Results	10
4.6 Pilot Interface Test Conclusions	10
5 PCA Mode/Display Tests (Aug. 1994).....	10
5.1 PCA Mode/Display Test Objectives.....	10
5.2 PCA Mode/Display Test Modes Tested	10
5.3 PCA Mode/Display Test Displays Tested	10
5.4 PCA Mode/Display Test Description	10
5.5 PCA Mode/Display Test Results	10
5.6 PCA Mode/Display Test Conclusions	14
6 PCA Full-Flight Envelope Tests (Apr. 1995).....	14
6.1 PCA Full-Flight Envelope Test Objectives	14
6.2 PCA Full-Flight Envelope Test Description.....	14
6.3 PCA Full-Flight Envelope Test Results.....	15
6.4 PCA Full-Flight Envelope Test Conclusions.....	16
7 Summary of Conclusions	19
Appendix A – PCA Control Law Block Diagram	21
Appendix B – PCA Longitudinal Control Law Equations	23
Appendix C – PCA Lateral-Directional Control Law Equation.....	25
Appendix D – PCA Coupled Approach Control Law Equations	27
Appendix E – PCA EPR Initial Conditions	29
Appendix F – PCA Responses to –3 Degree Flightpath Angle Command	31
Appendix G – PCA Responses to 10 Degree Bank Angle Command.....	33
References.....	35

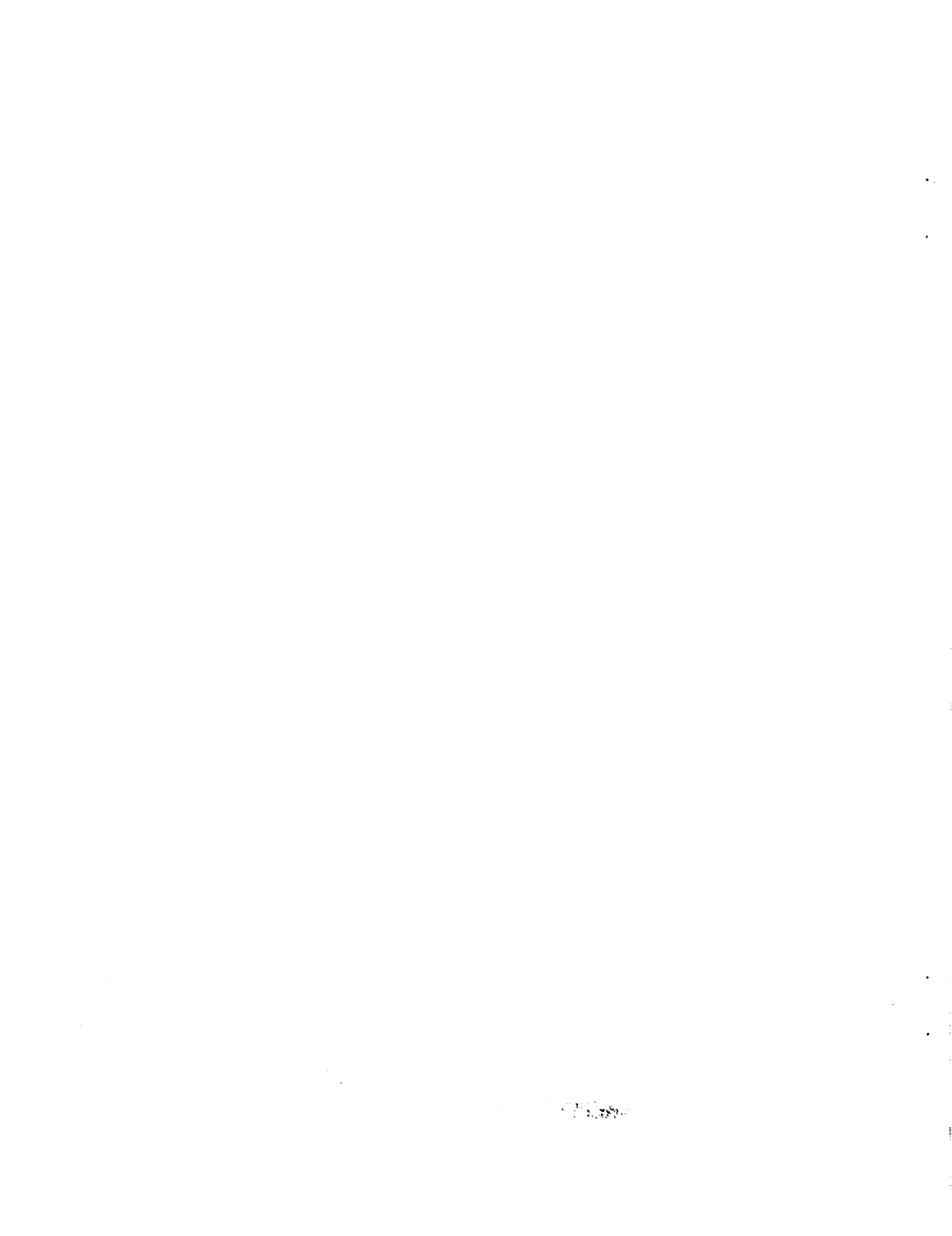

LIST OF TABLES

	Page
Table 1. ACFS facility description	2
Table 2. ACFS aircraft physical dimensions	2
Table 3. ACFS open loop dynamics	3
Table 4. ACFS light turbulence model amplitude and bandwidth.....	6
Table 5. PCA industry benefits.....	6
Table 6. PCA full-flight envelope test subject crews	14
Table 7. PCA full-flight envelope test matrix	14
Table 8. PCA full-flight envelope parameter test ranges.....	14
Table 9. PCA pilot workload	15

LIST OF FIGURES

	Page
Figure 1. ACFS open loop longitudinal dynamics.....	4
Figure 2. ACFS open loop lateral-directional dynamics	5
Figure 3. PCA implementation	7
Figure 4. PCA flightpath angle step responses at low, medium, and cruise altitudes	8
Figure 5. PCA bank angle step responses at low, medium, and cruise altitudes.....	9
Figure 6. MCP vs. sidestick pilot Cooper-Harper ratings	11
Figure 7. PCA mode pilot Cooper-Harper ratings	12
Figure 8. PCA heading vs. bank mode pilot preference	12
Figure 9. PCA display vs. no display pilot preference	13
Figure 10. PCA touchdown Footprints	13
Figure 11. PCA pilot Cooper-Harper ratings.....	15
Figure 12. PCA mode pilot preference	15
Figure 13. PCA operational limits with out-of-trim yaw moment.....	16
Figure 14. PCA approach time histories (manual throttle mode vs. PCA MCP mode)	17
Figure 15. PCA approach time histories (PCA fully coupled mode vs. PCA coupled localizer-only mode)	18

PRECEDING PAGE BLANK NOT FILMED

Piloted Simulation Tests of Propulsion Control as Backup to Loss of Primary Flight Controls for a Mid-Size Jet Transport

JOHN BULL,* ROBERT MAH, GLORIA DAVIS, JOE CONLEY, GORDON HARDY, JIM GIBSON,† MATTHEW BLAKE, DON BRYANT,‡ AND DIANE WILLIAMS‡

Ames Research Center

Summary

Partial failures of aircraft primary flight-control systems and structural damages to aircraft during flight have led to catastrophic accidents with subsequent loss of lives (e.g., DC-10 crash, B-747 crash, C-5 crash, B-52 crash, and others). These accidents can be prevented if sufficient alternate control authority remains which can be used by the pilot to execute an emergency safe landing.

Dryden Flight Research Center (DFRC) investigated the use of engine thrust for emergency flight control and has presented results of simulation and flight studies of several airplanes, including the B-720, Lear 24, F-15, B-727, C-402, and B-747. Using an F-15 aircraft, NASA DFRC successfully demonstrated in 1993 in a series of 36 flights, including actual propulsion controlled aircraft (PCA) landings, that throttle control of engines alone can be used to augment or replace the aircraft primary flight-control system to safely land the aircraft. NASA DFRC conducted flight tests in Aug.–Dec. 1995 of the MD-11 jet transport utilizing engine thrust for backup flight control.

A series of three piloted simulation tests have been conducted at Ames Research Center to investigate propulsion control for safely landing a mid-size jet transport which has experienced a total primary flight-control failure. The first series of tests was completed in July 1992 for the purpose of defining the best interface for the pilot commands to drive the engines. The second series of tests was completed in Aug. 1994 for the purposes of investigating PCA display requirements and to compare various PCA command modes. The third series of tests was completed in May 1995 for the purpose of investigating expanded PCA operational capabilities.

This report describes the concept of a PCA, discusses pilot controls, displays, and procedures; and presents the results of a series of three piloted simulation evaluations of the concept by a cross-section of air transport pilots.

*CAELUM Research Corporation, Mountain View, California.

†Recom Technologies, Inc., San Jose, California.

‡ManTech /NSI Technology Services Corporation, Sunnyvale, California.

1 Introduction

Partial failures of aircraft flight-control systems and structural damages to aircraft during flight have led to catastrophic accidents with subsequent loss of lives (ref. 1) (e.g., DC-10 crash, B-747 crash, L-1011 crash, and C-5 crash). These accidents can be prevented if sufficient alternate control authority remains which can be used by the pilot to execute an emergency safe landing.

Following the DC-10 accident at Sioux City, Iowa in 1989, the National Transportation Safety Board recommended "Encourage research and development of backup flight-control systems for newly certified wide-body airplanes that utilize an alternate source of motive power separate from that source used for the conventional control system" (ref. 2). The problem in the general case is that currently there is no satisfactory method onboard the aircraft for effectively controlling the aircraft with a disabled primary flight-control system. In addition, manual throttle control of engines is extremely difficult because of pilot unfamiliarity with dynamic response of the aircraft in this mode.

Dryden Flight Research Center (DFRC) investigated the use of engine thrust for emergency flight control and has presented results of simulation and flight studies of several airplanes, including the B-720, Lear 24, F-15, B-727, C-402, and B-747 (refs. 3 and 4). Using an F-15 aircraft, DFRC successfully demonstrated in 1993 in a series of 36 flights, including actual propulsion controlled aircraft (PCA) landings, that throttle control of engines alone can be used to augment or replace the aircraft primary flight-control system to safely land the aircraft (refs. 5 and 6). The DFRC concept used specifically developed control laws in the aircraft flight-control computer system to drive the engines in response to pilot input commands for bank angle and flightpath angle. The PCA system flight hardware and software was developed and implemented by McDonnell Douglas Aircraft (MDA) Company. As a follow-on to the F-15 PCA flight tests, DFRC and MDA have developed and implemented PCA control laws for the MD-11 jet transport. Flight tests are planned to take place in Aug.–Dec. 1995 (ref. 7).

Ames Research Center (ARC) has conducted three PCA piloted simulation tests for a mid-size jet transport in support of and complementary to the PCA tests conducted by DFRC.

This report describes the concept of a PCA, discusses pilot controls, displays, and procedures; and presents the results of a series of three piloted simulation evaluations of the concept by a cross-section of air transport pilots.

1.1 Purpose of Each Series of NASA Ames Piloted Simulation Tests

A series of three piloted simulation tests have been conducted at ARC to investigate propulsion control for safely landing a mid-size jet transport which has experienced a total primary flight-control failure. The first series of tests was completed in July 1992 for the purpose of defining the best interface for the pilot commands to drive the engines. The second series of tests was completed in Aug. 1994 for the purposes of investigating PCA display requirements and to compare various PCA command modes. The third series of tests was completed in May 1995 for the purpose of investigating expanded PCA operational capabilities throughout the full-flight envelope.

2 Simulation Aircraft Description

The piloted simulations were conducted in the Advanced Concepts Flight Simulator (ACFS) at ARC (table 1).

2.1 ACFS Facility Description

The ACFS is a moving base simulator representative of a mid-size two-engine jet transport with engines located

Table 1. ACFS facility description

Cockpit	B-757 controls and displays
Autopilot	B-757 mode control panel All auto modes functional
Out the window scene	High fidelity night visual scenes
Cab motion	High fidelity cab motion
Data collection	Time histories Touchdown snapshots Video and audio tape

under the wings. The cab layout of pilot controls and displays is very similar to those of a typical Boeing jet transport with CRTs for pilot and copilot primary flight displays and map displays, and with a typical Boeing mode control panel (MCP) located above the instrument panel for selection of various autopilot modes. The visual out-the-window display is a night visual scene for landing at San Francisco Runway 28R.

2.2 ACFS Aircraft Physical Dimensions

The ACFS aircraft model physical dimensions are similar to those of a Boeing 757 aircraft (table 2). The ACFS aircraft model has a nominal landing weight of 180,000 lb and a wing span of 140 ft, with one engine located beneath each wing. The engines are located 23.8 ft out-board from the aircraft center of gravity (cg), and 11.7 ft beneath the aircraft cg.

2.3 ACFS Aircraft Flight Dynamics

The ACFS aircraft model flight dynamics characteristics are typical of a jet transport similar to a B-757. The

Table 2. ACFS Aircraft physical dimensions

Similar to a mid-size jet transport (B-757)	
Gross weight	
Empty	121,660 lb
Takeoff	225,000 lb
Landing	180,000 lb
Moments of inertia	
I_{xx}	2,111,000 slug-ft ²
I_{yy}	4,290,000 slug-ft ²
I_{zz}	6,063,000 slug-ft ²
I_{xz}	280,000 slug-ft ²
Dimensions	
Wing area	2169.9 ft ²
Wing span	139.7 ft
Mean chord	17.5 ft
Mean aerodynamic center	52.0%
Nominal landing cg	27.8%
Engines	
Max thrust	42,000 lb
Xeng	48.8 ft
Yeng	23.8 ft
Zeng	11.7 ft

frequency and damping of the ACFS open loop dynamics for a typical PCA approach configuration (table 3) is representative of a mid-size jet transport. Time histories of the longitudinal modes and lateral-directional modes are shown in figures 1 and 2.

2.4 ACFS Turbulence Model

ACFS turbulence mathematical models provide turbulence rms values and bandwidths (table 4) which are representative of values specified in Military Specifications Mil-Spec-8785 D of April 1989. Translational turbulence along each translational stability axis is generated by a random number generator driving a first order filter at a frequency dependent upon altitude and airspeed. Rotational turbulence about the pitch axis is generated by a first order filter driven by an output correlated with vertical gusts, rotational turbulence about the yaw axis is generated by a first order filter driven by an output correlated with lateral gusts, and rolling turbulence is generated by a random number generator driving a first order filter at a frequency dependent upon altitude and airspeed.

3 PCA Concept and Control Laws

PCA control laws provide aircraft longitudinal flight control through parallel throttle movement fore and aft to control climb or descent flightpath. PCA control laws provide aircraft lateral-directional flight control through asymmetric throttle movement to control bank angle. PCA concept implementation is depicted in figure 3. PCA control law implementation is shown in more detail in

Appendix A, and PCA control law equations are shown in Appendices B, C, and D.

3.1 PCA Control Law Development

PCA control law structure and gains were developed using an analytical model of the ACFS aircraft and the MATLAB Control System Toolbox. Gains were initially optimized to provide sufficiently tight steady state tracking in light turbulence while keeping thrust excursions within acceptable limits. Gains were then refined to slightly increase damping for improved step transient responses.

The PCA control law initial exhaust pressure ratio (EPR) trim point is determined from an EPR trimmap rather than simply using the EPR values at PCA engage. This initialization method is used because the pilot, in an attempt to fly the aircraft on manual throttles, could possibly have moved the engines far from a desired straight and level trim condition prior to PCA engage. Appendix E shows the EPR trimmap for straight and level flight.

3.2 PCA Typical Step Response Time Histories

PCA time histories to step commands of -3 deg flightpath angle and 10 deg bank angle are shown in figures 4 and 5. The time constants for the longitudinal responses are approximately 4 sec at 2000 ft altitude, 8 sec at 15,000 ft altitude, and 15 sec at 35,000 ft altitude. The time constants for the bank command step responses are approximately 3 sec at 2000 ft altitude, 6 sec at 15,000 ft altitude, and 10 sec at 35,000 ft altitude.

Table 3. ACFS Open loop dynamics

Trim condition		
Weight = 180,000 lb, altitude = 2000 ft		
No flaps, landing gear down, cg = 27.8%		
Longitudinal short period		
Freq. = 1.60 rad/sec	Period = 3.9 sec	Damping ratio = 0.60
Phugoid		
Freq. = 0.094 rad/sec	Period = 66.4 sec	Damping ratio = 0.090
Dutch roll		
Freq. = 1.04 rad/sec	Period = 6.0 sec	Damping ratio = 0.23
Spiral divergence		
tau = 31.0 sec	Time to double amplitude = 22.0 sec	
Roll-rate damping		
tau = 0.33 sec		

ACFS OPEN LOOP LONGITUDINAL DYNAMICS

W = 180,000 lbs; V = 180 kts; Alt = 2,000 ft
flaps = 0 deg; lg down; cg = 27.8%
All flight control surfaces at zero deflection.
Throttles at level flight trimmed thrust.

SHORT PERIOD

natural freq = 2.00 rad/sec. period = 3.14 sec
damped freq = 1.60 rad/sec. period = 3.92 sec.
damping ratio = 0.60

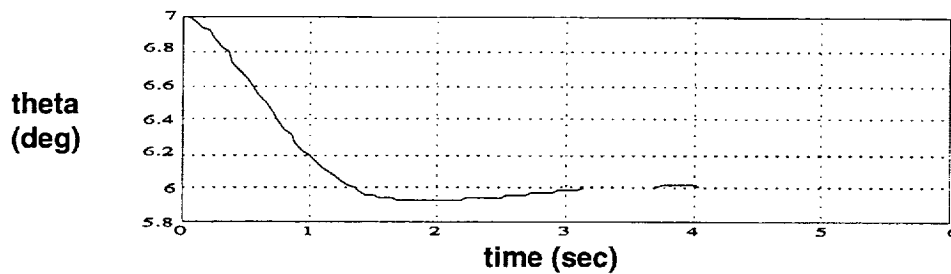

PHUGOID

natural freq = 0.095 rad/sec. period = 66.1 sec
damped freq = 0.094 rad/sec. period = 66.4 sec.
damping ratio = 0.090

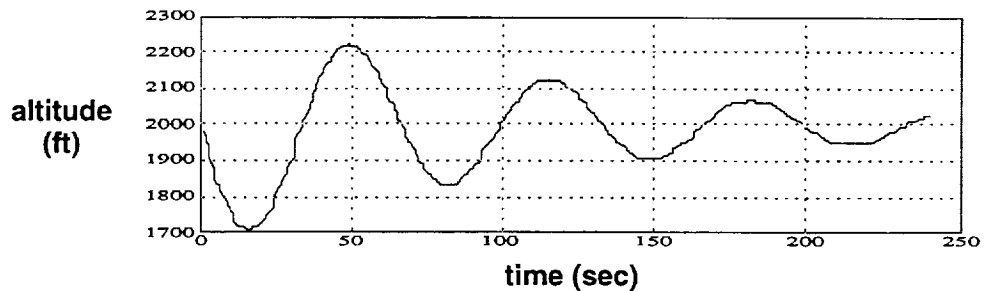
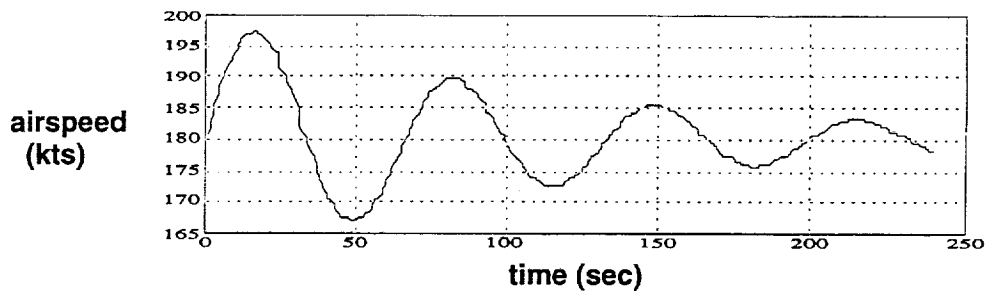

Figure 1. ACFS open loop longitudinal dynamics. The ACFS aircraft open loop longitudinal dynamics are very typical of a mid-size jet transport.

ACFS OPEN LOOP LATERAL-DIRECTIONAL DYNAMICS

W = 180,000 lbs; V = 180 kts; Alt = 2,000 ft
flaps = 0 deg; lg down; cg = 27.8%
All flight control surfaces at zero deflection.
Throttles at level flight trimmed thrust.

DUTCH ROLL

natural freq = 1.07 rad/sec. period = 5.9 sec
damped freq = 1.04 rad/sec. period = 6.0 sec.
damping ratio = 0.23

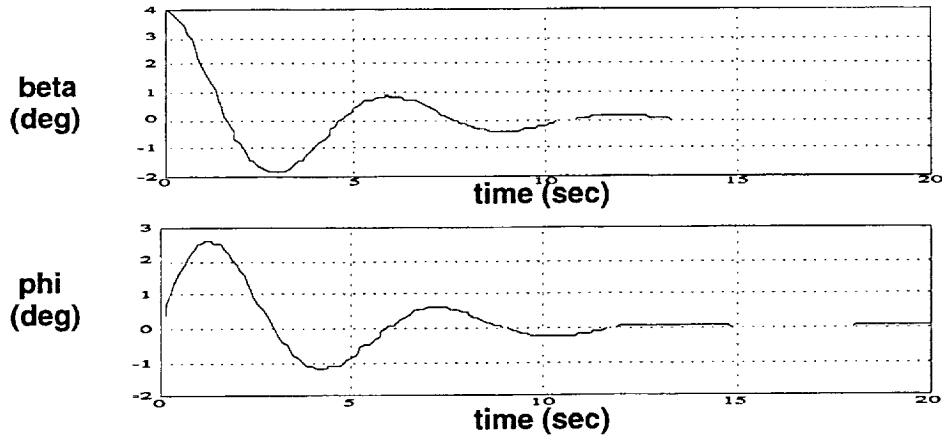

SPRIAL DIVERGENCE

tau = 31.0 sec.
time to double amp = 22 sec.

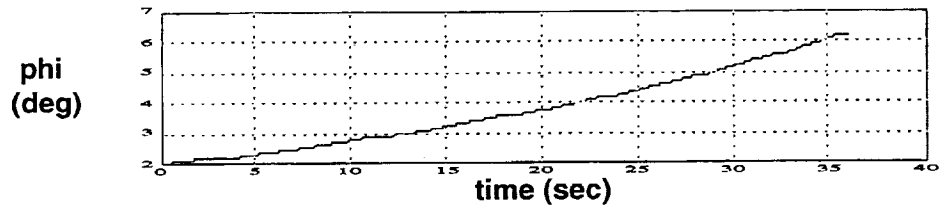

ROLL RATE DAMPING

tau = 0.33 sec

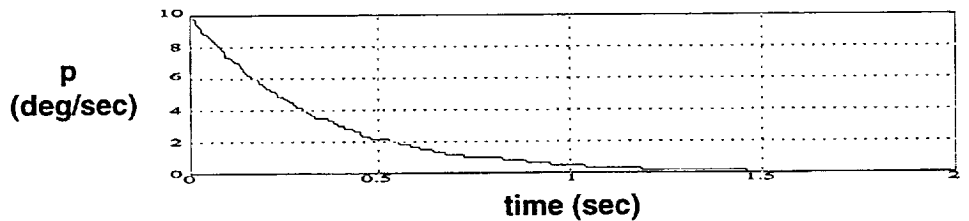

Figure 2. ACFS open loop lateral-directional dynamics. The ACFS aircraft open loop lateral-directional dynamics are very typical of a mid-size jet transport.

Table 4. ACFS Light turbulence model amplitude and bandwidth

Altitude = 1000 ft		Airspeed = 180 kts
Translational gusts		
	rms value (kts)	Bandwidth (rad/sec)
u axis	1.8	0.5
v axis	1.4	0.5
w axis	<u>1.7</u>	0.5
Total	2.9	
Rotational gusts		
	rms value (deg/sec)	Bandwidth (rad/sec)
p gusts	0.50	1.4
q gusts	0.40	1.4
r gusts	<u>0.50</u>	1.4
Total	0.84	

Note: Gust amplitude and bandwidth depend on airspeed and altitude.

3.3 PCA Industry Benefits

The results of a study (ref. 8) to identify PCA industry benefits are shown in table 5. The study was conducted for a the 30 year life cycle of a fleet of 300 aircraft in the category of 400,000 lb takeoff gross weight. It was assumed that PCA allows mechanical backup flight controls to be eliminated, PCA training costs are equal to mechanical backup costs, PCA saves one aircraft over a 30 year period, and insurance is 5 percent less for a PCA-equipped aircraft.

Table 5. PCA industry benefits

Safety	
• Eliminate catastrophic accidents due to loss of primary flight control	
Economic	
• Weight reduction saves	\$295M
• Insurance savings	42M
• Saved airplane	110M
• PCA certifications costs	<u>-10M</u>
Total life cycle savings	\$436M

4 Pilot Interface Tests (June 1992)

4.1 Pilot Interface Test Objective

Objective of Pilot Interface tests completed in July 1992 was to compare two PCA controller modes: (1) sidestick controller and (2) thumbwheel controller.

4.2 Pilot Interface PCA Modes

The PCA sidestick controller mode tested was one in which the pilot used the conventional sidestick controller to command roll rate and flightpath angle rate. The PCA thumbwheel controller mode tested was one in which the pilot used the bank angle knob and the vertical speed knob on the conventional autopilot MCP to command bank angle and flightpath angle.

4.3 Pilot Interface Test Displays

The primary flight display was programmed with symbology to assist the control task. Commanded and actual flightpath angle, relative to the aircraft symbol, were presented against the pitch ladder of the attitude director indicator, and commanded and actual roll angle were presented against the roll index.

4.4 Pilot Interface Test Description

A total of six NASA pilots participated in the tests and conducted over 100 simulated approaches and landings. Evaluation criteria included pilot comments, Cooper-Harper ratings, and touchdown performance. Approaches were conducted in two configurations: (1) no flaps and 170 kts airspeed, and (2) 40 deg flaps and 145 kts airspeed. Approaches were conducted in both light and moderate turbulence. Initial condition was trimmed straight and level flight at 1,800 ft above the ground (AGL), 10 nautical miles (nm) from the runway, and 1000 ft lateral offset to the left of centerline.

PCA IMPLEMENTATION

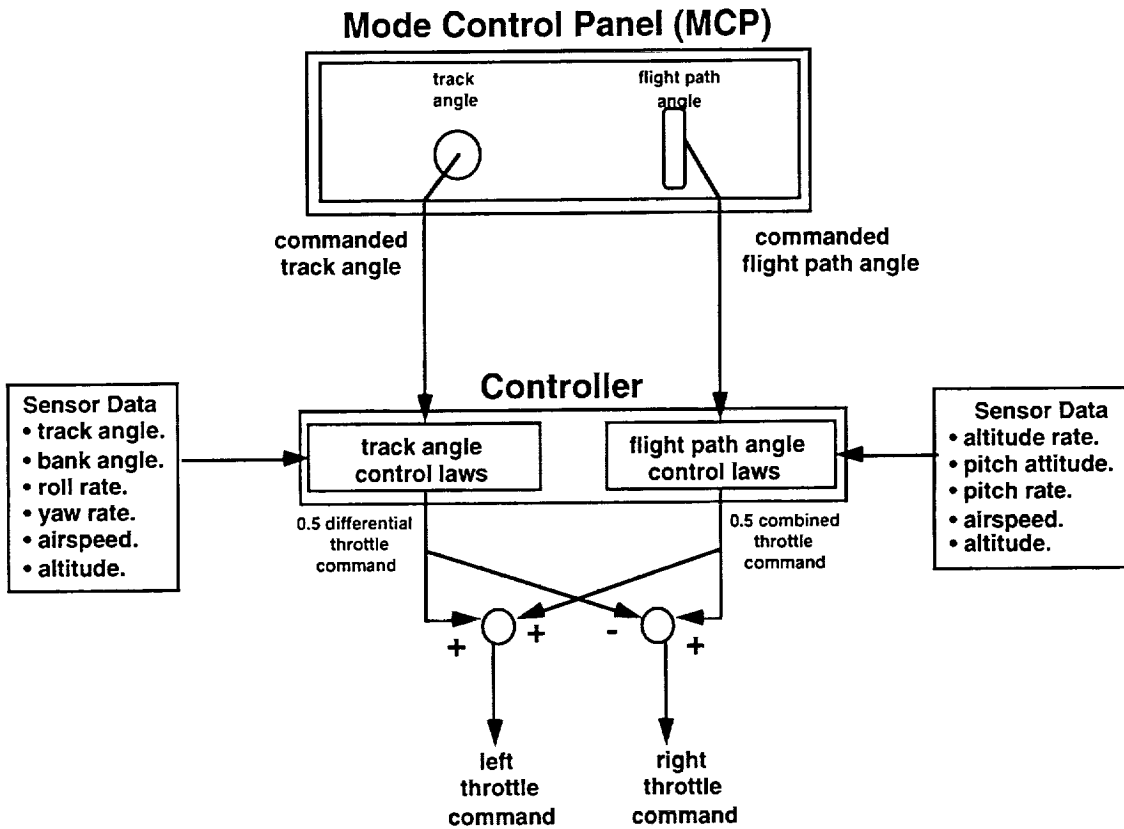
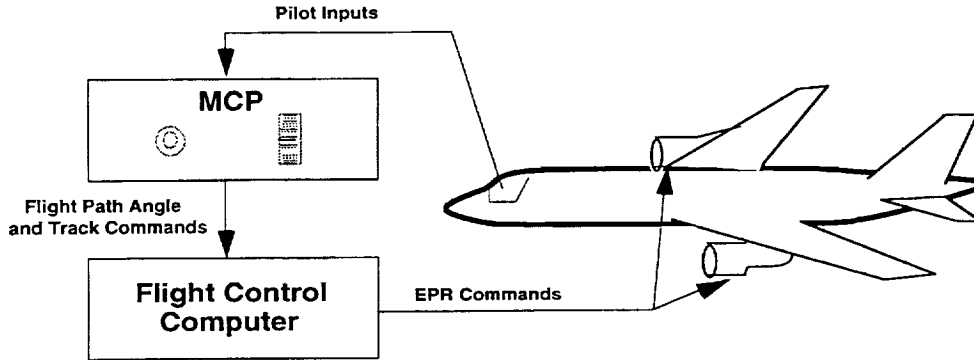

Figure 3. PCA implementation. The PCA cockpit controls and displays, sensors, and pilot procedures are the same as for conventional autopilot operation. PCA hardware and software implementation costs, and pilot training requirements are minimized.

PCA STEP RESPONSE TO -3 DEGREE FLIGHT PATH ANGLE STEP COMMAND FOR LOW, MEDIUM, AND CRUISE ALTITUDE

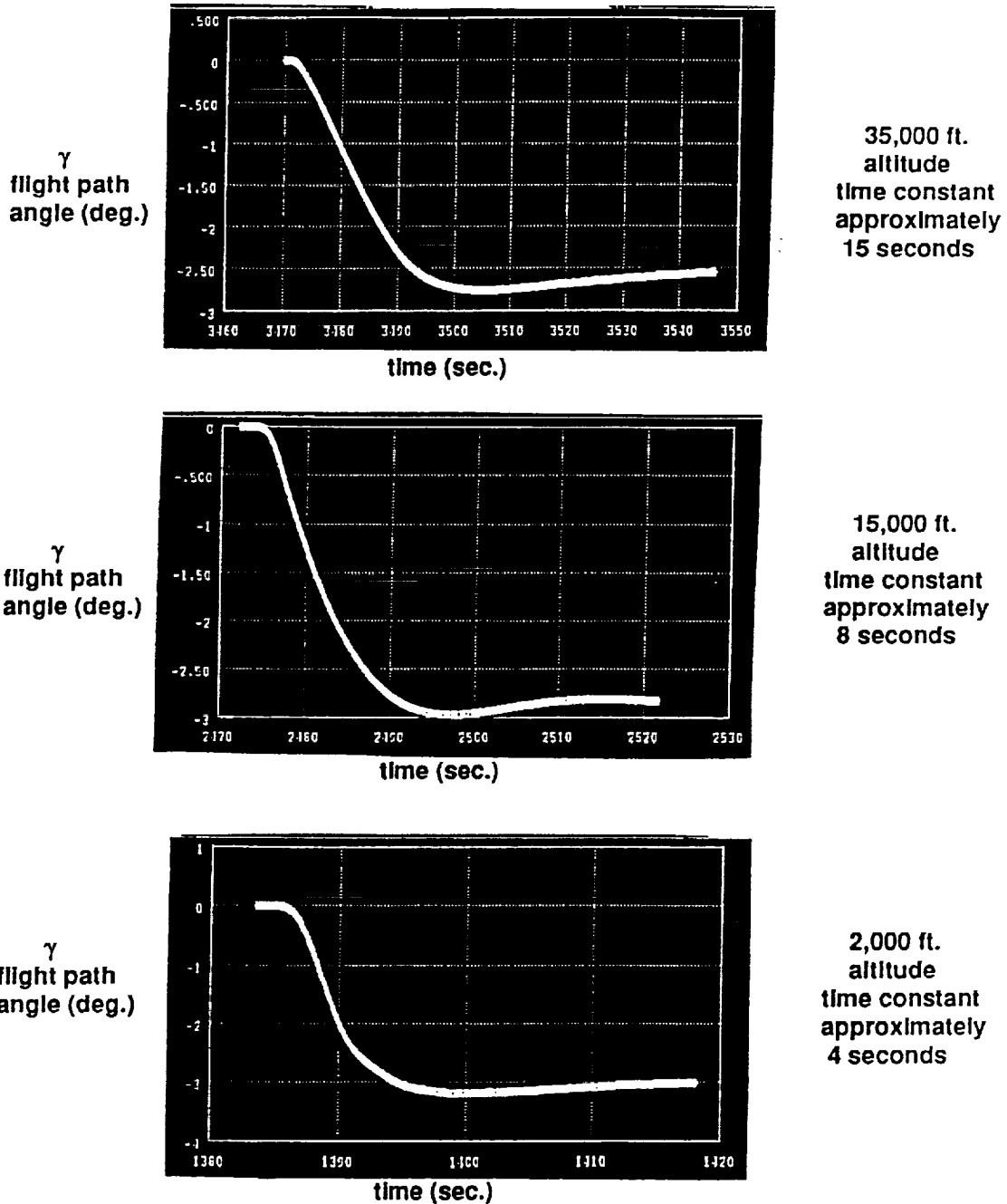

Figure 4. PCA flightpath angle time history step response. The PCA flightpath angle closed loop control time constants at low altitude are sufficiently fast for approach and landing; and at medium and cruise altitudes are slower, but sufficiently fast for satisfactory flightpath control.

PCA STEP RESPONSE TO 10 DEGREE BANK ANGLE STEP COMMAND FOR LOW, MEDIUM, AND CRUISE ALTITUDE

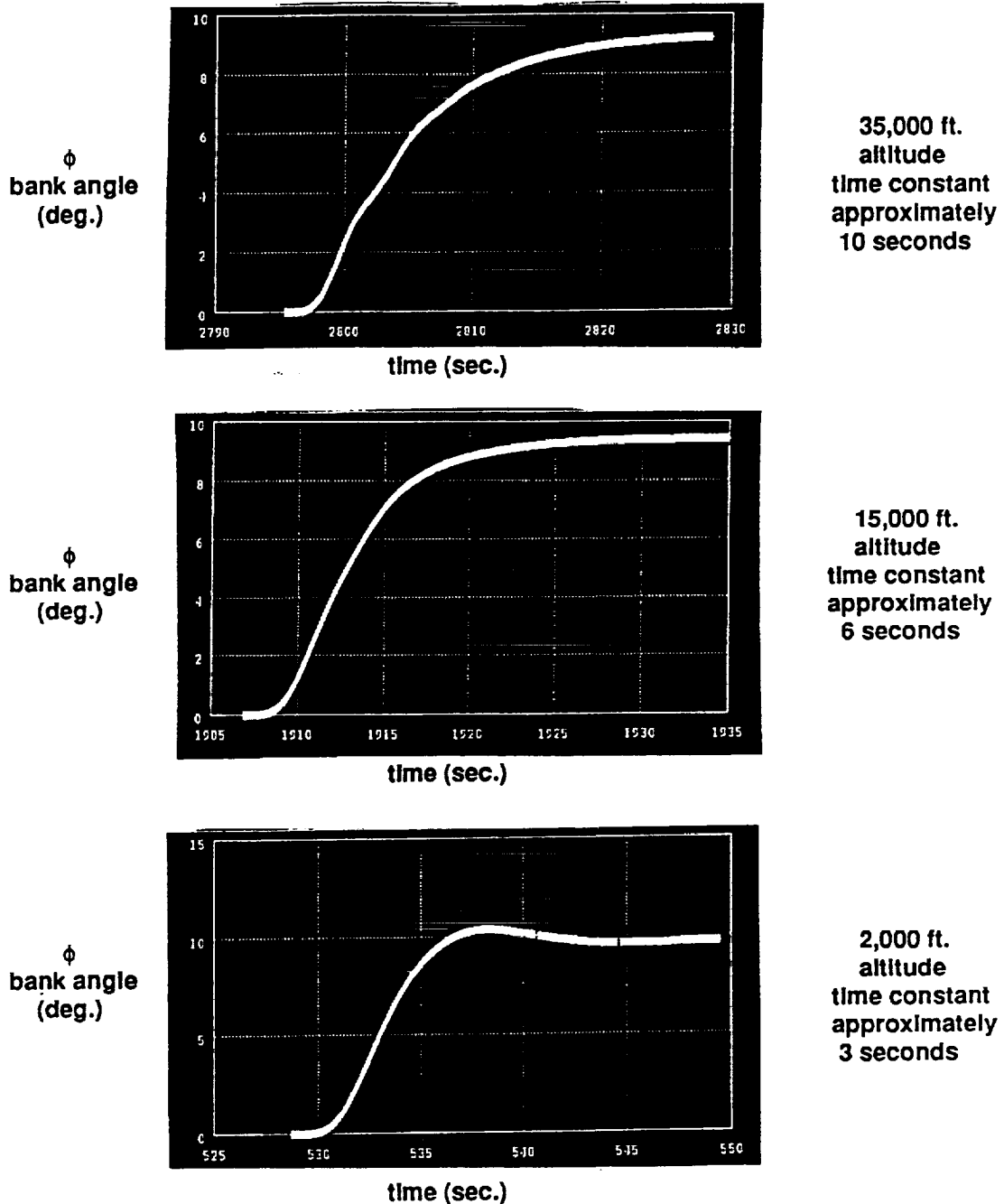

Figure 5. PCA bank angle time history step response. The PCA bank angle closed loop control time constants at low altitude are sufficiently fast for approach and landing; and at medium and cruise altitudes are slower, but sufficiently fast for satisfactory flightpath control.

4.5 Pilot Interface Test Results

The sidestick control mode was slow and required continuous pilot attention to achieve a desired command. It was difficult to make precise simultaneous multi-axis inputs with the sidestick. The thumbwheel mode allowed desired commands to be set quickly using the digital window as feedback. A disadvantage of the thumbwheel bank command was that the control knob had no zero angle detent, thus requiring the pilot to look down in the cockpit to determine if he had commanded zero bank angle.

The task defined for the Cooper-Harper ratings was to land on the runway with a sink rate of less than 16 fps, bank angle of less than 10 deg, and touchdown on the first half of the runway. In all cases investigated (no flaps, 40 deg flaps, light and moderate turbulence), pilots preferred the thumbwheel controller to the sidestick controller. Average Cooper-Harper ratings for each case is shown in figure 6. The mean rating with 0 deg flaps in the sidestick mode was 4.5 compared to a mean rating with the MCP thumbwheel of 3.6. The mean rating with 40 deg flaps in the sidestick mode was 5.1 compared to a mean rating with the MCP thumbwheel of 3.9.

4.6 Pilot Interface Test Conclusions

Pilots preferred the MCP thumbwheel controller to the sidestick controller for PCA approach and landing.

5 PCA Mode/Display Tests (Aug. 1994)

5.1 PCA Mode/Display Test Objectives

Objectives of the PCA Mode tests completed in Aug. 1994 were (1) to evaluate PCA bank mode vs. PCA heading mode, and (2) to investigate PCA performance enhancement with additional displays.

5.2 PCA Mode/Display Test Modes Tested

The PCA heading mode was one in which the pilot controlled aircraft heading by commanding heading through the heading select knob on the MCP. The PCA bank mode was one in which the pilot controlled aircraft bank angle by commanding bank angle by using the same heading select knob on the MCP. In the bank mode, the signals from the heading select knob represent bank commands rather than heading commands. PCA flightpath angle control was provided by pilot inputs using the MCP vertical speed knob. A digital command readout was provided above both the heading knob and the vertical speed knob.

5.3 PCA Mode/Display Test Displays Tested

Symbology was added to the conventional primary flight director display to provide feedback to the pilot on commanded flightpath angle and commanded bank angle in addition to normal digital readouts on the MCP. The commanded flightpath angle was a horizontal green bar which moved vertically to the commanded flightpath angle on the pitch attitude indicator. The commanded bank angle command was achieved by rolling the same horizontal green bar to the commanded bank angle.

5.4 PCA Mode/Display Test Description

The test matrix and approach sequence flown by each pilot was carefully planned in order to obtain statistically significant and valid data for comparison purposes. Prior to conducting test data approaches, each pilot received an hour of checkout of the cab conventional controls and displays, three approach and landings with conventional sidestick and conventional autopilot modes, and three PCA training approaches. In addition, the order of PCA test data approaches was varied for each subject pilot to eliminate mode sequence from statistical significance.

A total of 13 pilots (NASA, FAA, airline, and industry) participated in the tests and conducted 261 approaches in either bank mode or heading mode (half with and half without the additional PCA displays on the primary flight director). Approaches were conducted in both light and moderate turbulence. Initial approach point condition was trimmed straight and level flight at 2000 ft above the ground (AGL), 10 nautical miles (nm) from the runway, and 2000 ft lateral offset to the left of centerline. Evaluation criteria included pilot comments, Cooper-Harper ratings, approach flightpath control performance, and touchdown performance.

5.5 PCA Mode/Display Test Results

The PCA heading command mode required significantly less pilot workload for approach and landing than did the PCA bank command mode. This was because the pilot is required to input fewer commands using the MCP heading command knob than is required when using the bank command MCP knob. In addition, the bank angle command knob had no zero detent, thus requiring the pilot to look down at the digital readout to determine if he had commanded zero bank angle. However, pilots commented that they felt they had more immediate control in the bank command mode, particularly when crossing the runway

**ACFS PILOTED SIMULATION TESTS, June 1992
PCA MCP KNOBS vs PCA SIDESTICK
(Bank Angle Command Mode)**

**PILOT COOPER-HARPER RATINGS
6 Pilots (NASA)**

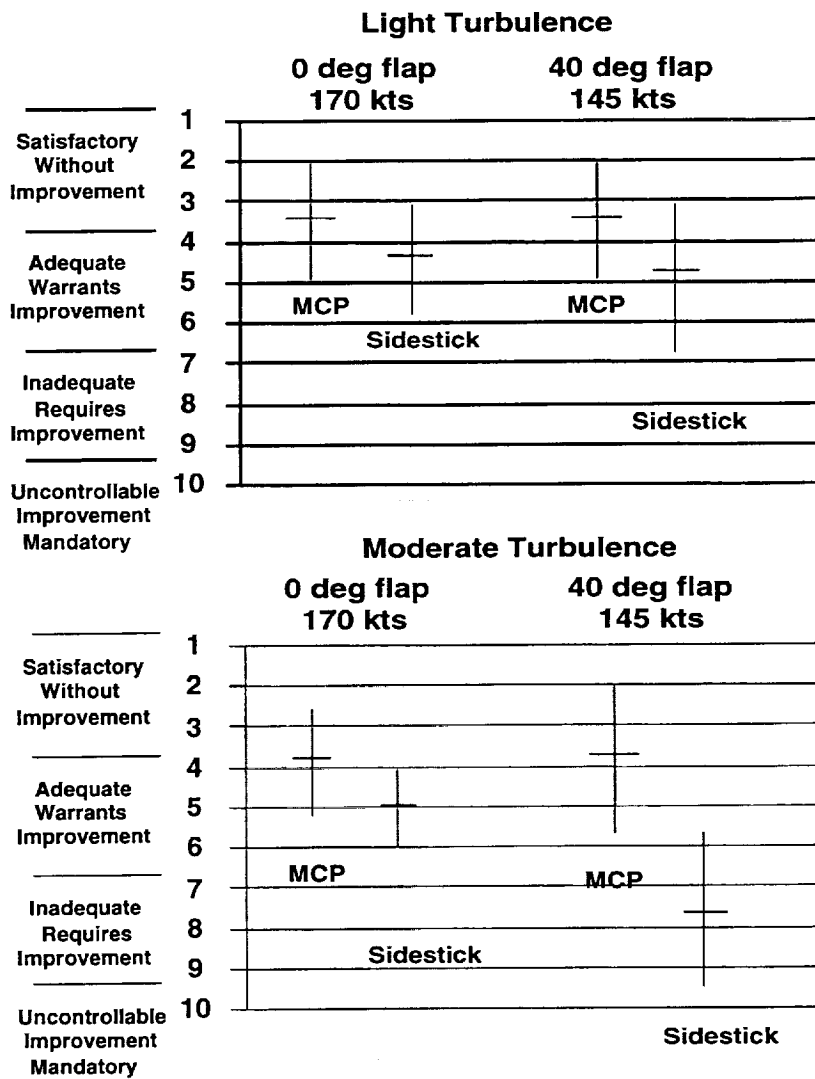

Figure 6. MCP vs. sidestick pilot Cooper-Harper ratings. Pilot preferred the autopilot Mode Control Panel (MCP) thumb-wheel and vertical speed knob as the best interface for pilot commands to the PCA flight-control laws.

threshold and preparing for touchdown. Both the PCA heading command mode and the PCA bank command mode received mean Cooper-Harper ratings (3.4 and 3.2) in the "satisfactory to adequate" range (fig. 7). Pilots preferred slightly the PCA heading command mode over the PCA bank command mode (fig. 8).

The PCA symbology displays provided feedback to the pilot on the commanded bank/heading angle and flight-path angle, and the aircraft response to the command. This feedback did not provide pilots with information that was useful to the task of approach and landing, and required pilots to spend more time "heads down" in the cockpit.

ACFS PCA PILOTTED SIMULATION TESTS, August 1994

PCA COOPER-HARPER RATINGS 13 Pilots (6 NASA, 1 FAA, 4 Airline, 2 Airframe) 27 deg flaps, 145 kts., Light Turbulence, 5 kt. left crosswind

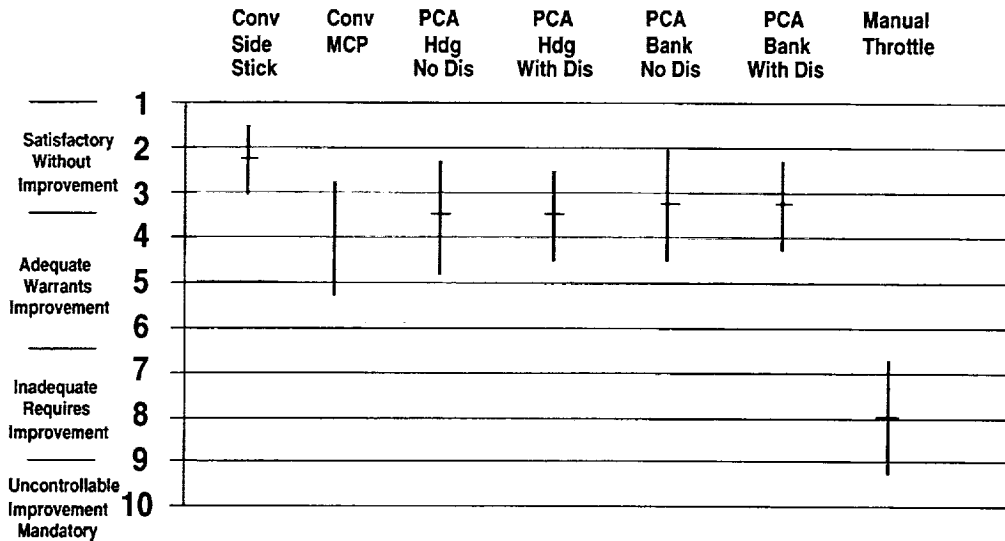

Figure 7. PCA Mode pilot Cooper-Harper ratings. PCA heading and bank modes were both rated in the adequate to satisfactory range, while the PCA manual throttle mode was rated as unacceptable.

HEADING vs BANK MODE PILOT PREFERENCE

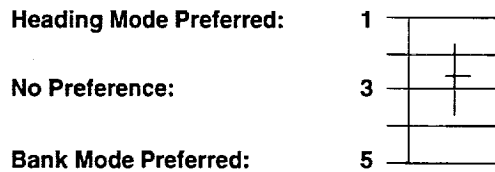

Figure 8. Heading vs. bank mode pilot preference. The PCA heading mode was preferred slightly over the PCA bank mode, primarily due to less number of required pilot MCP knob inputs during the approach.

Pilots relied primarily on the information feedback of the digital readouts of commanded bank/heading command and flightpath angle command. As a result, pilots did not desire or need additional PCA symbology (fig. 9).

PCA touchdown statistical dispersion data is shown in figure 10. Over half of the pilots were unable to complete a "manual throttle" approach on their first try. The longitudinal "phugoid" mode was particularly difficult for

pilots to control because the natural dynamic damping of this mode was so small. Typically, aircraft flightpath divergence was amplified when pilots allowed the bank angle to get too large while they were attempting to damp the phugoid mode. Pilot skill in conducting "manual throttle" approaches did improve with training, but the overall performance of "manual throttle" approaches was very poor even after some training, and pilots rated the "manual throttle" mode unacceptable.

DISPLAY vs NO DISPLAY PILOT PREFERENCE

Display Very Useful:	1	
Display Somewhat Useful:	3	
Display of No use:	5	

Figure 9. Display vs. no display pilot preference. Specific PCA displays did not enhance pilot performance or reduce pilot workload.

TOUCHDOWN FOOTPRINTS

27 deg flaps, Trim Airspeed = 145kts.
Light Turbulence, 5 kt. Left Crosswind

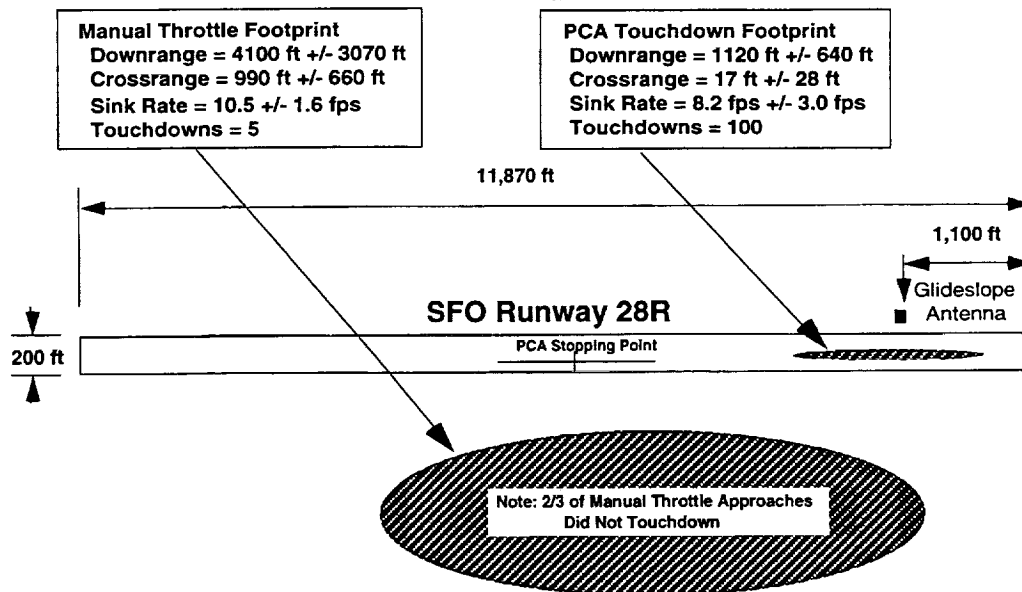

Figure 10. PCA touchdown footprints. PCA touchdown footprints and sink rates were consistently satisfactory, while manual throttle mode touchdown footprint and sink rate were unacceptable. Over half of the pilots were unable to complete a "manual throttle" approach on their first try. The longitudinal "phugoid" mode was particularly difficult for pilots to control because of the low natural dynamic damping of this mode. Typically, aircraft flightpath diverged when pilots allowed the bank angle to get too large while attempting to damp the phugoid mode.

5.6 PCA Mode/Display Test Conclusions

Pilots rated the bank mode and heading mode about equal (Cooper-Harpers both about 3.8), but preferred the heading mode over the bank mode. Additional displays for PCA on the primary flight director were not helpful in flying the approach and landing.

6 PCA Full-Flight Envelope Tests (Apr. 1995)

6.1 PCA Full-Flight Envelope Test Objectives

Objectives of the PCA full-flight envelope tests were to (1) evaluate and compare MCP knob track mode, fully coupled mode, and coupled localizer-only mode, (2) evaluate performance at medium and cruise altitudes, and (3) define operational limits with various turbulence levels, with various out-of-trim yaw moments and roll moments, and with various cg locations.

6.2 PCA Full-Flight Envelope Test Modes Tested

The PCA MCP knob track mode was one in which the pilot controlled aircraft ground track by commanding ground track through the heading select knob on the MCP, and controlled the flightpath angle through the vertical speed knob on the MCP. The PCA fully coupled mode was one in which the Instrument Landing System (ILS) glide slope and localizer signals were used to compute appropriate PCA bank angle and flightpath angle commands, thereby allowing the aircraft to be flown

“hands off” in a fully automatic mode to touchdown. An autoflare mode initiated at 120 ft altitude was included in the PCA fully coupled mode. The PCA coupled localizer-only mode was one in which the ILS localizer signal was used to compute PCA bank angle command to automatically track runway centerline, while the pilot controlled flightpath angle with the MCP vertical speed knob.

6.2 PCA Full-Flight Envelope Test Description

A total of 10 pilots (table 6) participated in the tests and conducted 160 approaches (table 7). Evaluation criteria included pilot comments, Cooper-Harper ratings, approach performance time history data, touchdown performance “snapshot” data, and post-test pilot questionnaires. Approaches were conducted at 180 kts and 250 kts with no flaps. In addition, PCA was flown at 15,000 ft altitude and 35,000 ft altitude. A range of parameters relevant to PCA was tested (table 8).

Table 6. PCA full-flight envelope test subject crews

ALPA	2 Airline captains
ATA	1 Airline pilot
Airline training	1 MD-11 Instructor
Air cargo	1 Air cargo pilot
	1 Military pilot
Airframe companies	2 Aircraft company test pilots
NASA	2 Test pilots

Table 7. PCA full-flight envelope test matrix

Altitude (ft)	Initial airspeeds			
	Manual throttle	PCA MCP knobs	PCA coupled	PCA loc-only
2000	180 kt	180 kt	180 kt	180 kt
5000		250 kt	250 kt	
15,000		240 kt		
35,000		260 kt		

Table 8. PCA full-flight envelope parameter test ranges

Failed rudder offsets	0–4 deg
Failed aileron offsets	0–2 deg
Failed stabilator cg positions	Trimmed airspeeds from 145 kt to 260 kt 24% – 36%
Turbulence	None, light, moderate, heavy
Mean wind	20 kts from 30 deg left and right

6.3 PCA Full-Flight Envelope Test Results

The PCA MCP track command mode using the MCP heading select knob and vertical speed knob required less pilot workload than heading command mode and bank angle mode did in previous tests (table 9). This was because the track mode automatically establishes correct crab angles for the pilot in crosswinds. In addition the track mode produced smaller engine thrust excursions in turbulence because of the less noisy inertial feedback signal of track angle as compared to heading or bank angle feedback in turbulence.

The PCA MCP track mode, fully coupled mode, and coupled loc-only mode all received adequate to satisfactory mean pilot Cooper-Harper ratings (fig. 11). PCA mode

order of pilot preference was PCA coupled localizer-only slightly over the PCA fully coupled mode, and PCA fully coupled mode slightly over the PCA MCP track knob mode (fig. 12).

PCA approach and landing performance was acceptable in no turbulence up to a maximum of 3 deg rudder out of trim yaw moment. As turbulence is increased, engines began to hit idle sooner and more often. Thus, there was an operationally acceptable limit tradeoff of rudder offset vs. turbulence (fig. 13). PCA was acceptable in no turbulence up to a maximum of 1.5 deg of aileron out of trim roll moment. It is important to recognize that these maximum values of rudder and aileron out of trim moments are very vehicle dependent, and would vary substantially with the number of engines and physical thrust moment arms

Table 9. PCA pilot workload

Approach Initiated in Trimmed Condition; 180 kts; no flaps; 12 nm from runway; 2000 ft offset to left; and 2000 ft altitude	
Typical number of pilot MCP knob inputs on PCA approach and landing	
Longitudinal mode	
Flightpath angle	8 (1 per 25 sec)
Lateral-directional modes	
Bank-angle mode	50 (1 per 4 sec)
Heading mode	16 (1 per 12 sec)
Track-angle mode	8 (1 per 25 sec)
Loc only track angle	1 (1 per 200 sec)

ACFS PCA PILOTTED SIMULATION, April 1995
COOPER-HARPER RATINGS

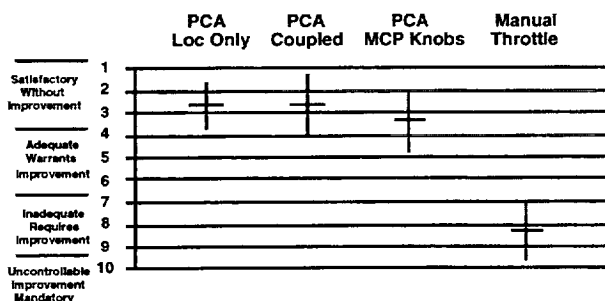

Figure 11. PCA pilot Cooper-Harper ratings. PCA coupled localizer-only mode and fully coupled mode were rated in the satisfactory range, PCA MCP track mode was rated in the adequate to satisfactory range, while PCA manual throttle mode was rated in the inadequate range.

PILOT MODE PREFERENCES

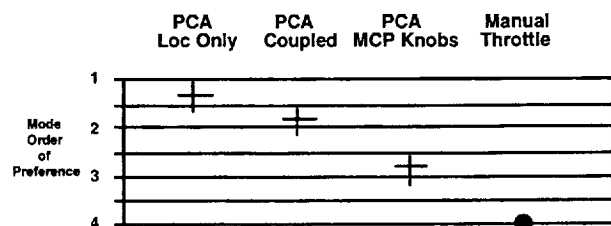

Figure 12. Pilot PCA mode preferences. Pilot mode order of preference was coupled localizer-only over the fully coupled, and then the MCP track knob mode. Coupled localizer-only mode allows the pilot to concentrate on glideslope control with the MCP vertical speed knob while the localizer is tracked automatically.

of any particular aircraft. In the case of the DC-10 accident (ref. 2) at Sioux City Iowa, the out of trim yaw moment due to airflow out of the hole in one side of the center engine nacelle due to the explosion, was approximately equal to a 3 deg rudder offset.

Time histories of typical PCA approaches are shown in figures 14 and 15 for comparison purposes.

In the event of a complete flight-control failure, a major consideration is the fact that the resulting trim airspeed is dependent on three factors: (1) failed stabilator position, (2) aircraft gross weight, and (3) aircraft cg position. Of major importance is the fact that the trimmed calibrated airspeed at time of flight-control failure will be close to the trimmed calibrated airspeed for all altitudes, including landing (App. E). Thus, if the failure occurs at cruise altitude and airspeed (for example, 270 kts calibrated), the pilot will be faced with a fairly high trimmed airspeed for approach and landing. If the failed stabilator has no

backup, then trim airspeed is subject primarily to aircraft gross weight and cg position. The pilot then has the option, if available, to reduce the trimmed airspeed for landing by either dumping fuel to reduce gross weight or by moving the cg aft. In the case of the ACFS aircraft, trim airspeed could be reduced approximately 6 knots per 10,000 lb of fuel dumped, or 11 knots per 1 percent of aft cg movement.

6.4 PCA Full-Flight Envelope Test Conclusions

Pilot mean Cooper-Harper ratings were in the "satisfactory" range for the PCA coupled localizer-only mode (2.7) and the PCA fully coupled mode (2.8), and in the "adequate" range for the PCA MCP track knob mode (3.2). Pilot mode order of preference was PCA coupled localizer-only slightly over the PCA fully coupled mode, and PCA fully coupled mode slightly over the PCA MCP track knob mode.

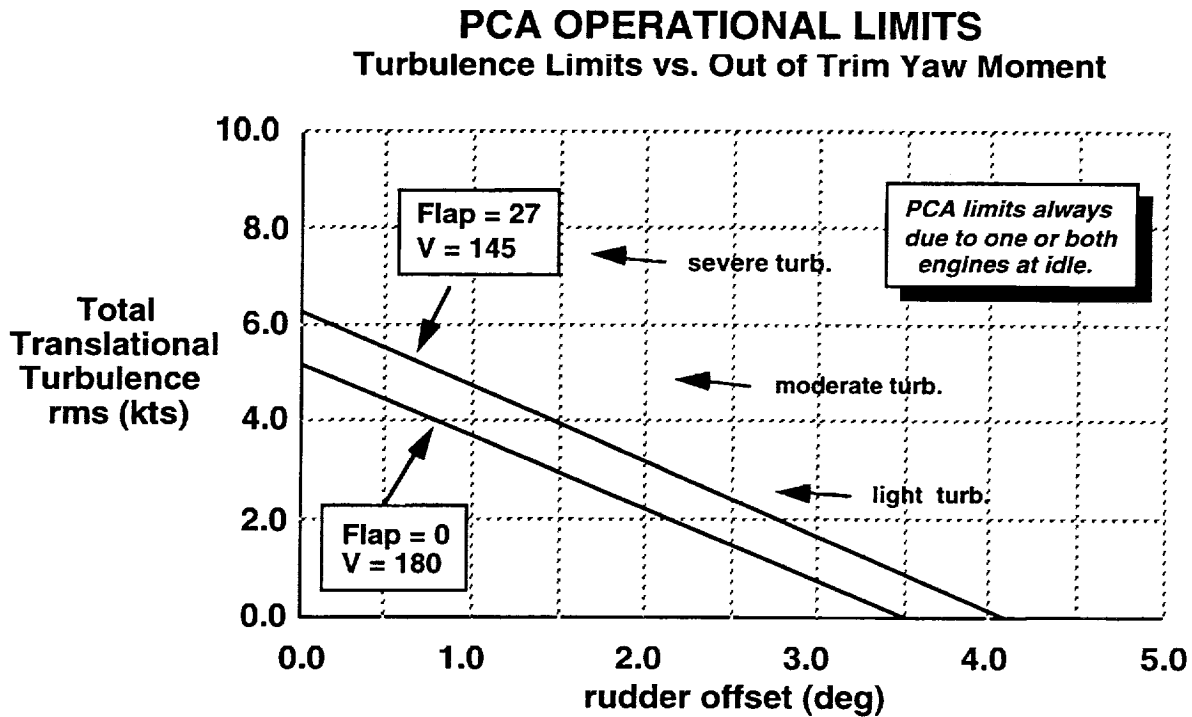

Figure 13. PCA operational limits. PCA control authority to out of trim yaw moment was limited to approximately 3 deg rudder offset due to one engine beginning to remain too long at the idle stop. Maximum values of rudder and aileron out of trim moments are very vehicle dependent, and would vary substantially with the number of engines and physical thrust moment arms of any particular aircraft. In the case of the DC-10 accident (ref. 2) at Sioux City, Iowa; the out of trim yaw moment due to airflow out of the hole in one side of the center engine nacelle due to the explosion, was approximately equal to a 3 deg rudder offset.

PCA APPROACH TIME HISTORIES

(very light turbulence, 10 kt. left crosswind)

Manual Throttle Approach

PCA MCP Track Mode

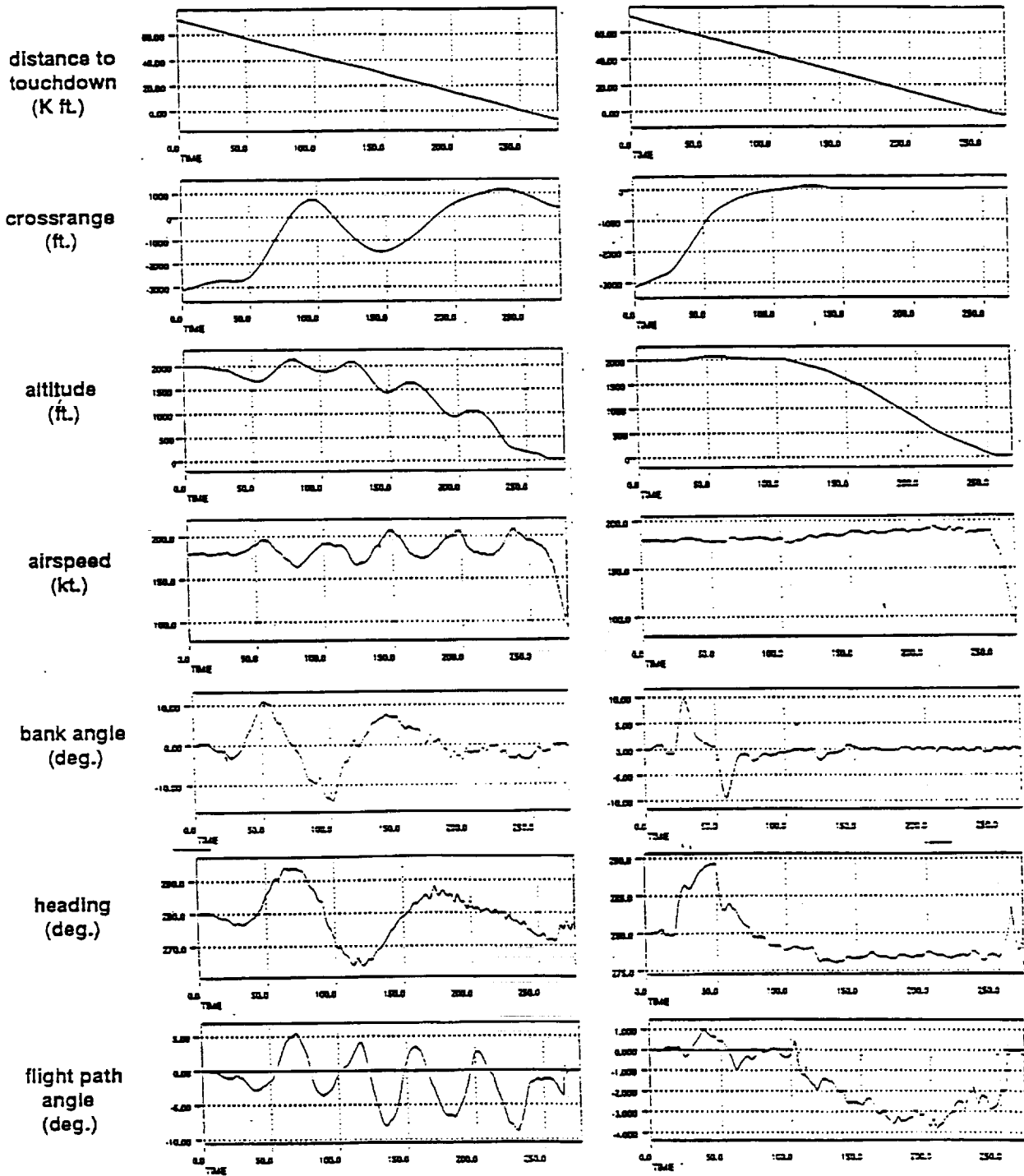

Figure 14. Manual throttle approach vs. PCA MCP track mode approach time histories. Phugoid damping was extremely difficult in the manual throttle mode. PCA MCP track mode control laws provided good damping.

PCA APPROACH TIME HISTORIES

(light turbulence, 10 kt. left crosswind)

PCA Fully Coupled Approach

PCA Coupled Localizer-Only Mode

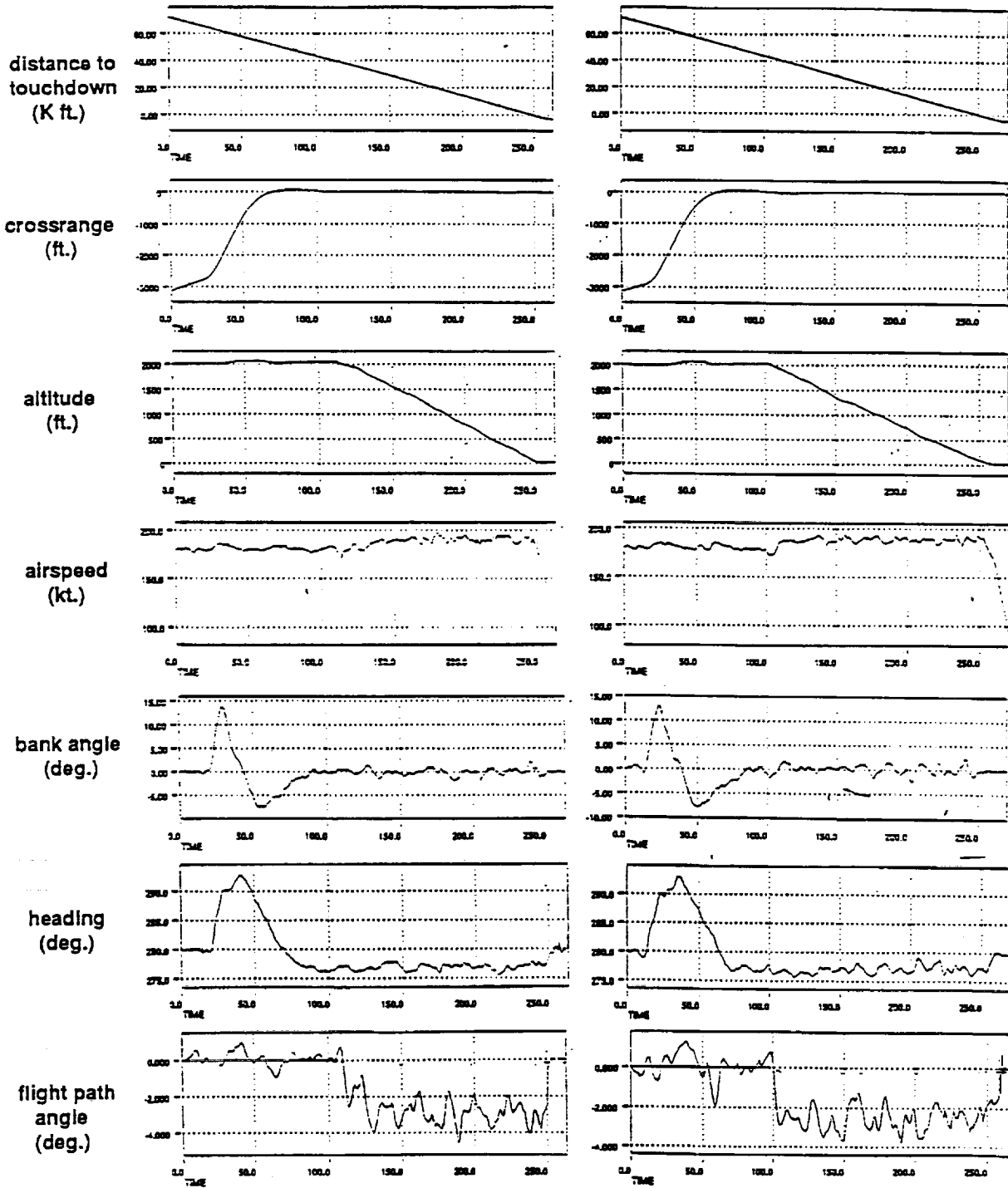

Figure 15. PCA coupled approach time histories. PCA coupled approach performance was acceptable up to moderate levels of turbulence. Increased levels of turbulence resulted in engines remaining too long and too often at idle thrust.

PCA workload in terms of total MCP knob inputs was significantly less for the coupled modes compared to the MCP track mode.

PCA approach and landing acceptable performance limit in turbulence with no out of trim moments was moderate turbulence (5 kts translational rms, 1.8 deg/sec rotational rms).

PCA approach and landing acceptable performance out of trim limits in no turbulence were a maximum of 3 deg rudder out of trim yaw moment and a maximum of 1.5 deg aileron out of trim roll moment. These maximum values of rudder and aileron out of trim moments are very vehicle dependent, and would vary substantially with the number of engines and physical thrust moment arms of any particular aircraft.

PCA performance was slower, but adequate at medium and cruise altitudes.

Aircraft trim airspeed could be reduced approximately 11 knots per 1 percent of aft cg movement, and approximately 6 knots per 10,000 lb of fuel dumped.

7 Summary of Conclusions

Industry Benefits Study

Eliminate catastrophic accidents due to loss of primary flight control. Save approximately \$436M over the 30 year life cycle of a fleet of 300 jet transports (400K lb takeoff gross weight).

Operational Consideration

If a total primary flight-control failure occurs at cruise altitude and airspeed (for example, 270 kts calibrated), the pilot is faced with a fairly high trimmed airspeed for approach and landing. If the failed stabilator has no backup, then trim airspeed is determined primarily by aircraft gross weight and cg position. The pilot then has the option, if available, to reduce the trimmed airspeed for landing by either dumping fuel to reduce gross weight or by moving the cg aft.

June 1992, PCA Pilot Interface Tests

Pilots preferred the MCP thumbwheel controller to the sidestick controller for PCA approach and landing.

Aug. 1994, PCA Mode/Display Tests

Pilots rated the bank mode and heading mode about equal (Cooper-Harpers both about 3.8), but preferred the heading mode over the bank mode. Additional displays for PCA were not helpful in flying the approach and landing.

Apr. 1995, Full-Flight Envelope Tests

Pilot mean Cooper-Harper ratings were in the "satisfactory" range for the PCA coupled localizer only mode (2.7) and the PCA fully coupled mode (2.8), and in the "adequate" range for the PCA MCP track knob mode (3.2). Pilot mode order of preference was PCA coupled localizer only slightly over the PCA fully coupled mode slightly over the PCA MCP track knob mode.

PCA workload in terms of total MCP knob inputs was significantly less for the Coupled Modes compared to the MCP Track Mode.

PCA approach and landing acceptable performance limit in turbulence with no out of trim moments was moderate turbulence (5 kts translational rms, 1.8 deg/sec rotational rms).

PCA approach and landing acceptable performance out of trim limits were a maximum of 3 deg rudder out of trim yaw moment and a maximum of 1.5 deg aileron out of trim roll moment. Maximum values of rudder and aileron out of trim moments are very vehicle dependent, and would vary substantially with the number of engines and physical thrust moment arms of any particular aircraft.

Aircraft trim airspeed could be reduced approximately 11 knots per 1 percent of aft cg movement, or approximately 6 knots per 10,000 lb of fuel dumped.

PCA performance was slower, but adequate at medium and cruise altitudes.

Appendix A – PCA Control Law Block Diagram

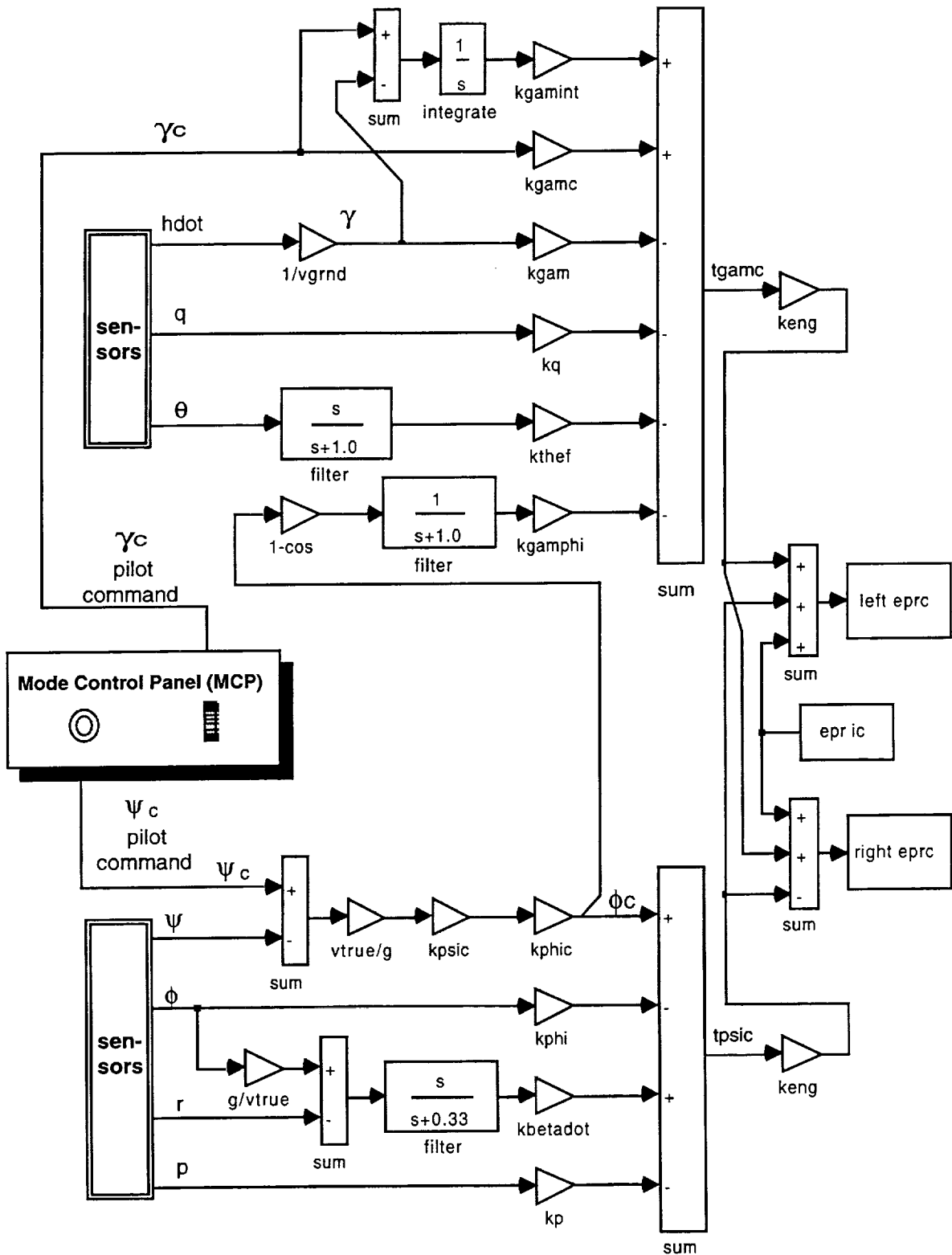

Appendix B – Longitudinal PCA Control Laws

e_{pgamc} = delta exhaust pressure ratio (EPR) commanded/engine for flightpath angle control
 t_{gamc} = delta thrust commanded/engine (lb/eng) for flightpath angle control
 γ_c = commanded flightpath angle (deg)
 (pilot input from MCP knob in MCP mode, calculated in ILS Coupled mode)

ϕ_c = commanded bank angle (deg)
 (pilot input from MCP knob in Bank mode, calculated in MCP Track mode)

Longitudinal Control Law Structure

$t_{gamc} = k_{gamref}[(k_{gamc}*\gamma_c - k_{gam}*\gamma) + k_{gamint}*\gamma_{int} - k_q*q - k_{thef}*\theta_f + k_{gamphi}*\gamma\phi]$

$e_{pgamc} = t_{gamc}*k_{eng}$

$\gamma_{int} = (\gamma_c - \gamma)/s$, absolute value $\gamma_{int} < 40$

$\theta_f = [s/(s + 1/tauth_{ef})]*\theta$

$\gamma\phi = [1/(s + 1)][1 - \cos(\phi_c)]$

Longitudinal Control Law Gains

$k_{eng} = 1/42000$

$k_{gamref} = 0.5*W*t_{gain}*k_{eng}/57.3$

$k_{gamc} = 2.60$

$k_{gam} = 2.60$

$k_{gamint} = 0.15$

$k_q = 4.00$

$k_{thef} = 8.00$

$tauth_{ef} = 1.00$

$W = a/c$ gross weight (lb)

Gain Scheduling (t_{gain} , k_{gamc} , k_{gamphi}) with Altitude and Airspeed

h = altitude (ft)

v_{cal} = calibrated airspeed (fps)

$t_{gain} = 1.0000 + 0.43123*h_1 - 0.0000525*h_2 + 0.0000423*h_3$

$h_1 = h/1000$, $h_2 = h_1*h_1$, $h_3 = h_1*h_2$

if $h > 3000$ ft

$k_{gamc} = 2.6 - 0.11*(h_1 - 3)$

if $h > 11000$ ft

$k_{gamc} = 1.8*(1 - h_{rat}*h_{rat})$, $h_{rat} = h/43000$

$k_{gamphi} = 45*(v_{rat}*v_{rat})$, $v_{rat} = 270/v_{cal}$

Appendix C – Lateral-Directional PCA Control Laws

- $\text{eprpsic} = \text{delta EPR commanded/engine for psi track angle control}$
 $\text{tpsic} = \text{delta thrust commanded/engine (lb/eng) for psi track angle control}$
 $\phi_c = \text{commanded bank angle, deg (pilot input from MCP knob in bank mode, or calculated when in track mode)}$
 $\psi_c = \text{commanded track angle, deg (pilot input from MCP knob in track mode, or calculated when in loc coupled mode)}$

Lateral-Directional Control Law Structure

- $\text{tpsic} = \text{kphiref} * [(\text{kphic} * \phi_c - \text{kgam} * f) - \text{kp} * p - \text{betastar}]$
 $\text{EPRpsic} = \text{tpsic} * \text{keng}$
 $\text{betastar} = [\text{kbetadot} * s / (s + 1/\text{taubdot})][g * f / v_{\text{true}} - r]$
 $\phi_c = \text{kpsic} * (v_{\text{true}} / g) * [\psi_c - \psi_{\text{trk}}]$ when in Track mode

Lateral-Directional Control Law Gains

- $\text{keng} = 1/42000$
 $\text{kphiref} = 0.0175 * \text{tgainphi}$

- $\text{kphic} = 1.53$
 $\text{kphi} = 1.70 + 0.1 * \text{flap}/27$
 $\text{kp} = 2.5$
 $\text{kbetadot} = -4.00$
 $\text{taubdot} = 3.00$
 $\text{taupsi} = 7.00$
 $\text{kpsic} = 1/\text{taupsi}$

Gain Scheduling (tgainphi, kpsic) with Altitude

- $h = \text{altitude (ft)}$
 $h1 = h/1000, h2 = h1 * h1, h3 = h1 * h2$
 $\text{tgain} = 1.0000 + 0.43123 * h1 - 0.0000525 * h2 + 0.0000423 * h3$
 $\text{tgainphi} = \text{tgain} * (1 - 0.72 * h/43000)$
 $\text{kpsic} = 1/\text{taupsi} - 0.072 * h/43000$

Appendix D – PCA IIs Coupled Control Laws

Glideslope Capture and Track Mode

gsdev = ILS Glideslope deviation (deg)

gsref = ILS Glideslope (deg)

• Glideslope Capture

if coupled approach is armed, and if glideslope deviation signal is active:

then gamtest = $kgamc * [gsref + kgs * gsdev] - kgam * \gamma$

if gamtest < 0:

then initiate glideslope track mode

• Glideslope Track Mode

tgamc = same as in PCA MCP mode, except that gc is now calculated as follows:

$\gamma_c = kgamc * [gsref - kgs * gsdev] - kgam * \gamma$

• Glideslope Track Gains

$kgamc = 2.8 + 0.4 * (287 / v_{true})^2$

kgamint = 0.04

$kgs = (x_{navgs} - 600) / (taugs * v_{true})$

taugs = 17.9

$x_{navgs} = x \text{ dist. to gs touchdown (ft)}$

$v_{true} = \text{true airspeed (fps)}$

Localizer Capture and Track Mode

locdev = ILS Localizer deviation (deg)

psiref = Localizer ground track (deg)

• Localizer Capture

if localizer approach is armed, and if localizer deviation signal is active:

then phitest = $psiref + kloc * locdev - \psi_{trk}$

if $\text{sign}(y_{nav}) * \text{phitest} > 0$: then initiate localizer track mode

• Localizer Track Mode

tpsic = same as in PCA MCP mode, except that γ_c is now calculated as follows:

$\psi_c = psiref + kloc * locdev + kpsiint * \psi_{int}$

• Localizer Track Gains

$kloc = x_{navloc} / (tauloc * v_{true})$

tauloc = 16.4

$x_{navloc} = x \text{ dist. to loc antenna (ft)}$

$v_{true} = \text{true airspeed (fps)}$

$kpsiint = 0.025 * 220 / v_{true}$

Autoflare

if altitude above runway < 120 ft: $\gamma_c = -2.2 - 4.6 * 304 / v_{true}$ ($-2.2 < \gamma_c < -1.5 \text{ deg}$)

If altitude above runway < 60 ft: $\phi_c = 0 \text{ deg}$

Appendix E – PCA EPR Initial Conditions

The PCA control law initial EPR trim point is determined from an EPR trimmap rather than simply using the EPR values at PCA engage. This initialization method is used

because the pilot, in an attempt to fly the aircraft on manual throttles, could possibly have moved the engines far from a desired straight and level trim condition prior to PCA engage.

Trimmed EPR_{ic} vs Stabilator Failed Position

Gross Weight = 180,000 lbs, cg = 27.8%

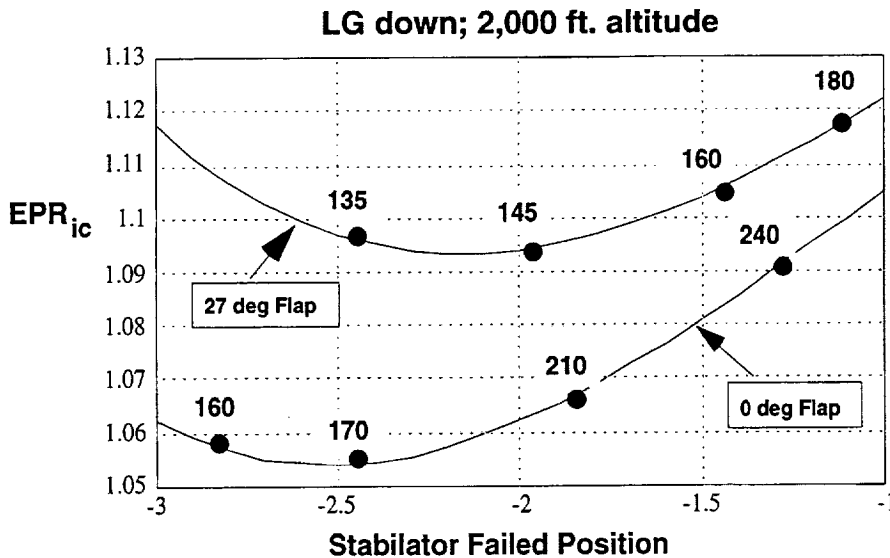
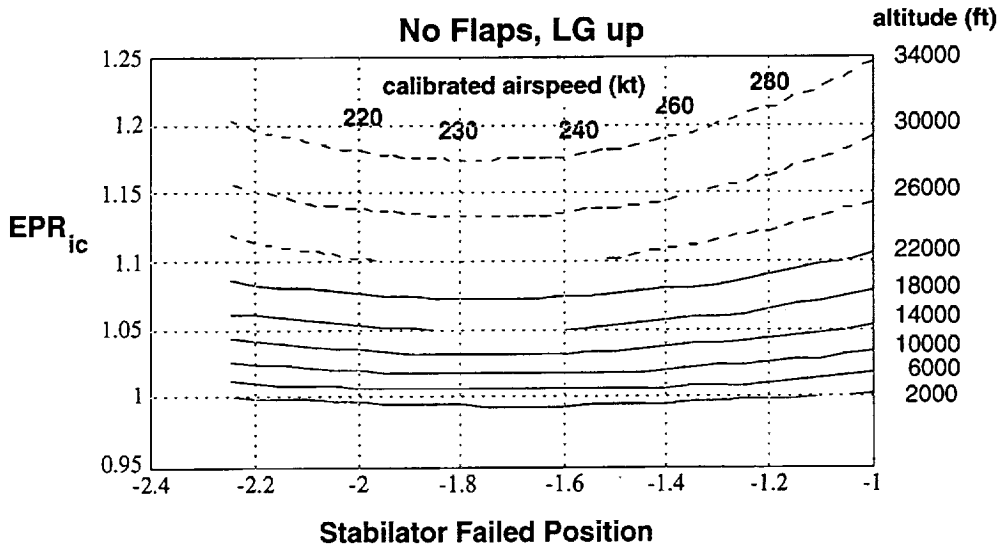



Appendix F – PCA Step Responses to -3 Degree Flightpath Angle Step Command
(no flaps; lg down; 2000 ft altitude)

flight path
angle
(deg.)

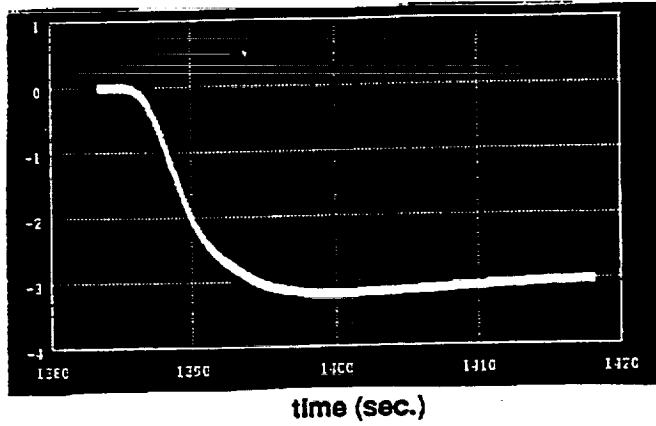

airspeed
(kt.)

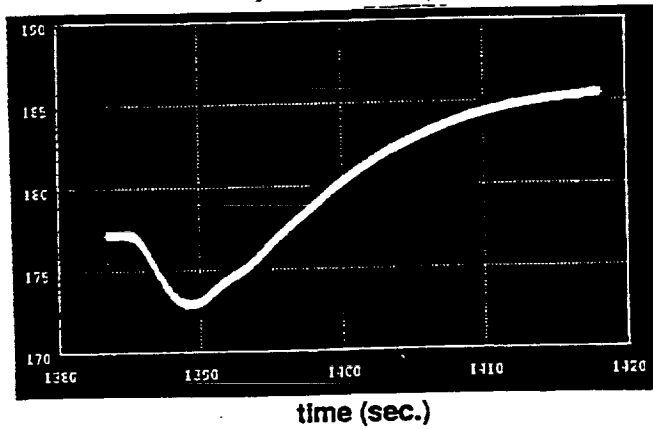

thrust per
engine
(lb.)

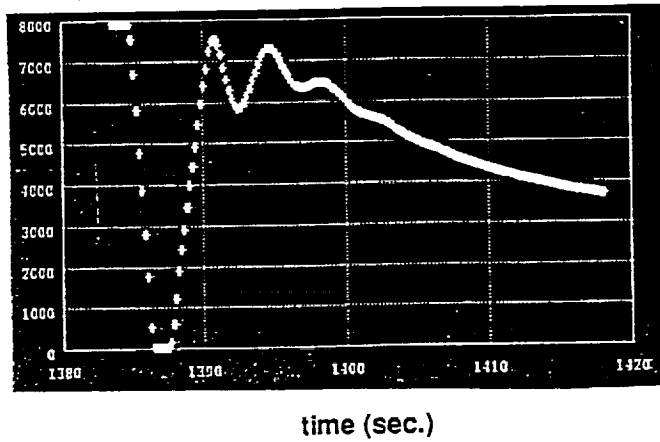

**Appendix G – PCA Responses to 10 Degree Bank Angle Step Command
(no flaps; lg down; 2000 ft altitude)**

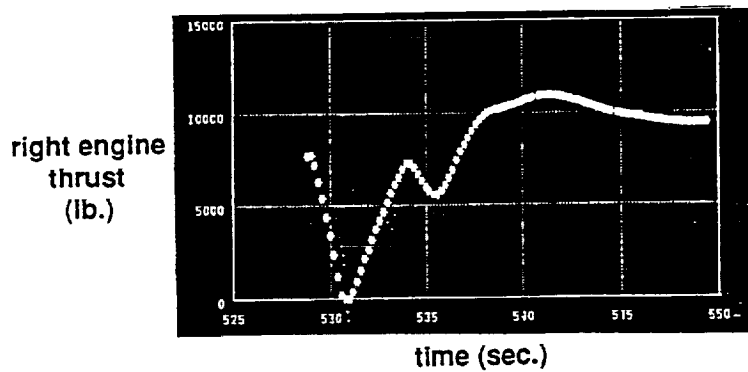
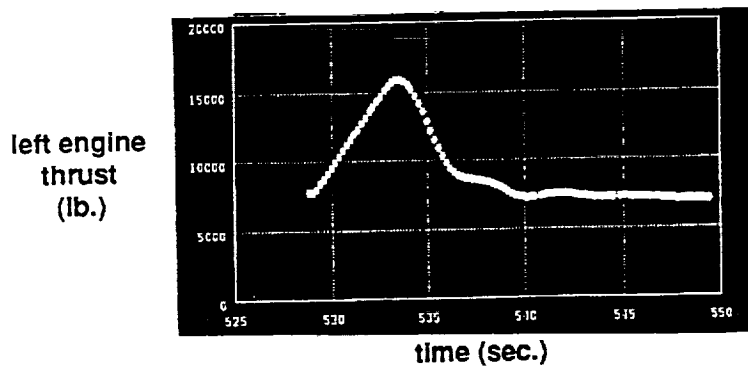
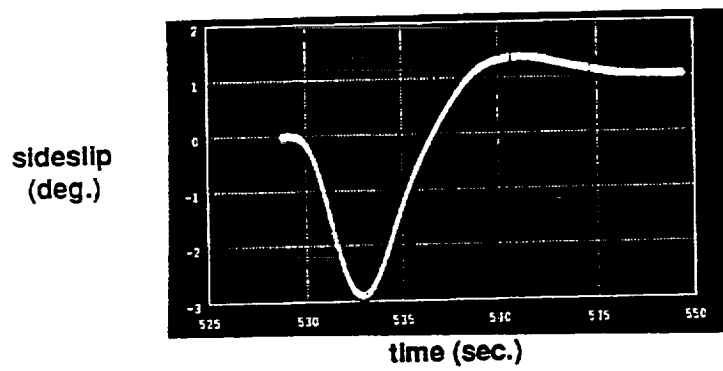
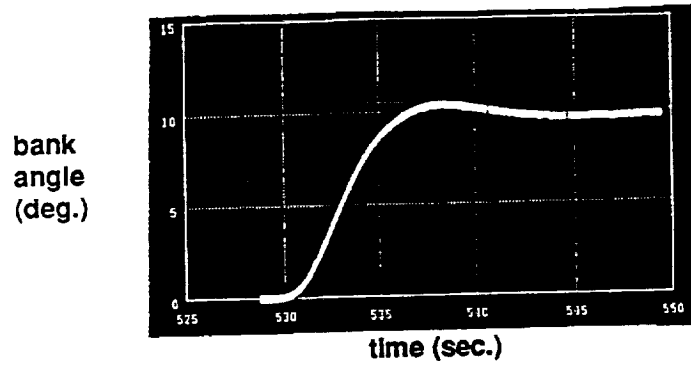

1. The first part of the document is a list of names and titles, including "The Hon. Mr. Justice G. D. C. O'Connell, Chief Justice of the Supreme Court of the State of New South Wales" and "The Hon. Mr. Justice G. D. C. O'Connell, Chief Justice of the Supreme Court of the State of New South Wales".

References

1. Burcham, F. W.; Fullerton, C. G.; Gilyard, G.; Wolf, T.; and Stewart, J.: A Preliminary Investigation of the Use of Throttles for Emergency Flight Control. AIAA-91-2222, June 1991.
2. National Transportation Safety Board, Aircraft Accident Report, PB90-910406, NTSB/AAR-90/06, United Airlines Flight 232, McDonnell Douglas DC-10, Sioux Gateway Airport, Sioux City, Iowa, July 1989.
3. Gilyard, F.; Conley, J.; Le, J.; and Burcham, F.: A Simulation Evaluation of a Four-Engine Jet Transport Using Engine Thrust Modulation for Flight Path Control. AIAA 91-2223, June 1991.
4. Burcham, Frank W., Jr.; and Fullerton, C. Gordon: Controlling Crippled Aircraft With Throttles. Flight Safety Foundation Paper and NASA TM-104238, Nov. 1991.
5. Burcham, Frank W., Jr.; Maine, Trindel; and Wolf, Thomas: Flight Testing and Simulation of an F-15 Airplane Using Throttles for Flight Control. AIAA-92-4109-CP and NASA TM-104255.
6. Burcham, F. W.; Maine, Trindel; Fullerton, Gordon; and Wells, Ed: Preliminary Flight Test Results of a Fly-By-Throttle Emergency Flight Control System on an F-15 Airplane. AIAA 93-1820, June 1993.
7. NASA Dryden Flight Research Center: MD-11 Propulsion Controlled Aircraft Project Schedule, July 1995.
8. Gelhausen, Paul: PCA Benefits Assessment. PCA Workshop, NASA Dryden, June 1993.

REPORT DOCUMENTATION PAGE

Form Approved
OMB No. 0704-0188

Public reporting burden for this collection of information is estimated to average 1 hour per response, including the time for reviewing instructions, searching existing data sources, gathering and maintaining the data needed, and completing and reviewing the collection of information. Send comments regarding this burden estimate or any other aspect of this collection of information, including suggestions for reducing this burden, to Washington Headquarters Services, Directorate for Information Operations and Reports, 1215 Jefferson Davis Highway, Suite 1204, Arlington, VA 22202-4302, and to the Office of Management and Budget, Paperwork Reduction Project (0704-0188), Washington, DC 20503.

1. AGENCY USE ONLY (Leave blank)		2. REPORT DATE December 1995	3. REPORT TYPE AND DATES COVERED Technical Memorandum	
4. TITLE AND SUBTITLE Piloted Simulation Tests of Propulsion Control as Backup to Loss of Primary Flight Controls for a Mid-Size Jet Transport			5. FUNDING NUMBERS 505-69-59	
6. AUTHOR(S) John Bull,* Robert Mah, Gloria Davis, Joe Conley, Gordon Hardy, Jim Gibson,† Matthew Blake, Don Bryant,‡ and Diane Williams‡				
7. PERFORMING ORGANIZATION NAME(S) AND ADDRESS(ES) Ames Research Center Moffett Field, CA 94035-1000			8. PERFORMING ORGANIZATION REPORT NUMBER A-960631	
9. SPONSORING/MONITORING AGENCY NAME(S) AND ADDRESS(ES) National Aeronautics and Space Administration Washington, DC 20546-0001			10. SPONSORING/MONITORING AGENCY REPORT NUMBER NASA TM-110374	
11. SUPPLEMENTARY NOTES Point of Contact: John Bull, Ames Research Center, MS 269-1, Moffett Field, CA 94035-1000; (415) 604-0083 *CAELUM Research Corporation, Mountain View, California. †Recom Technologies, Inc., San Jose, California. ‡ManTech/NSI Technology Services Corporation, Sunnyvale, California.				
12a. DISTRIBUTION/AVAILABILITY STATEMENT Unclassified-Unlimited Subject Category – 03			12b. DISTRIBUTION CODE	
13. ABSTRACT (Maximum 200 words) Failures of aircraft primary flight-control systems to aircraft during flight have led to catastrophic accidents with subsequent loss of lives (e.g., DC-10 crash, B-747 crash, C-5 crash, B-52 crash, and others). Dryden Flight Research Center (DFRC) investigated the use of engine thrust for emergency flight control of several airplanes, including the B-720, Lear 24, F-15, C-402, and B-747. A series of three piloted simulation tests have been conducted at Ames Research Center to investigate propulsion control for safely landing a medium size jet transport which has experienced a total primary flight-control failure. The first series of tests was completed in July 1992 and defined the best interface for the pilot commands to drive the engines. The second series of tests was completed in August 1994 and investigated propulsion controlled aircraft (PCA) display requirements and various command modes. The third series of tests was completed in May 1995 and investigated PCA full-flight envelope capabilities. This report describes the concept of a PCA, discusses pilot controls, displays, and procedures; and presents the results of piloted simulation evaluations of the concept by a cross-section of air transport pilots.				
14. SUBJECT TERMS Propulsion control, Jet transport, Piloted simulation			15. NUMBER OF PAGES 32	
			16. PRICE CODE A03	
17. SECURITY CLASSIFICATION OF REPORT Unclassified	18. SECURITY CLASSIFICATION OF THIS PAGE Unclassified	19. SECURITY CLASSIFICATION OF ABSTRACT	20. LIMITATION OF ABSTRACT	