

E9974
12-8-95

NASA Technical Memorandum 107096
AIAA-96-1150

Millennium Modem/Channelizer Special Test Equipment

William D. Ivancic
*Lewis Research Center
Cleveland, Ohio*

Prepared for the
16th International Communications Satellite Systems Conference
sponsored by the American Institute of Aeronautics and Astronautics
Washington, DC, February 25-29, 1996



National Aeronautics and
Space Administration

MILLENNIUM MODEM/CHANNELIZER SPECIAL TEST EQUIPMENT

William D. Ivancic
Senior Electronics Engineer
NASA Lewis Research Center
Cleveland, Ohio 44135

Abstract

A broadband modem/channelizer test set developed by NASA Lewis Research Center is discussed. The test set is a fully programmable, bit-error-rate (BER) test set designed for broadband modem-only and multichannel demultiplexer/demodulator characterization. It is currently configured for testing a multichannel demultiplexer/demodulator and was developed for the Advanced Research and Projects Agency under a Technology Reinvestment Program Cooperative Agreement entitled "Millennium: 21st Century Broadband Digital Telecommunications Technology." The test set can easily be modified to provide testing of other modems and multichannel demultiplexer/demodulator systems and is available to industry for such testing.

Millennium Modem/Channelizer

The Millennium modem/channelizer special test equipment has been developed for the Advanced Research and Projects Agency under the Technology Reinvestment Program Cooperative Agreement F33615-94-2-1442, entitled "Millennium: 21st Century Broadband Digital Telecommunications Technology." Participants in the signal-processing consortium are Raytheon's E-Systems Goleta Division, TRW, Incorporated, Electronics Systems and Technology Division, Honeywell Technology Center, and NASA Lewis Research Center. This consortium is developing the following hardware under this agreement: high-speed analog-to-digital (A/D) converters, various complementary heterojunction-field-effect-transistor, gallium-arsenide, application-specific integrated circuits (C-HFET GaAs ASIC's), and numerous communication and electronic warfare receivers. This paper describes the special test equipment designed to characterize the E-Systems wideband modem and channelizer.

Under the Millennium cooperative agreement, Raytheon is designing and fabricating a wideband channelizer and

modem using TRW-supplied A/D converters, and Honeywell- and Raytheon-supplied ASIC's. NASA Lewis Research Center is supplying the modem/channelizer test equipment and performing the final system characterization of the channelizer and modem.

The E-Systems Multichannel Demultiplexer/Demodulator (MCDD) is capable of demultiplexing fifteen 80-MHz wideband channels stacked across a 1.28-GHz frequency band (Fig. 1). The system is capable of demodulating 8-PSK (phase shift keying) modulated signals used in the wideband, optical carrier 3 (OC3) channels (155.52 Mb/sec throughput) (Fig. 2).

Transmission Characteristics for Onboard Processing Channelizers

A basic systems assumption about a satellite MCDD is that all channels being received are at relatively equal power levels. The power level is controlled by a closed-loop feedback system that permits power augmentation under fade conditions, such as during a rainstorm. Margins are built into the link budgets to ensure acceptable service during a fade condition. For the system envisioned, a fade margin of up to 6 dB has been allocated for fading. Thus, during extreme conditions that are still within the operational design criteria, the power in adjacent channels may be up to 6 dB higher than in the desired channel (Fig. 3). The A/D converters must have sufficient dynamic range to handle this scenario, since the gain control is achieved by mathematically adjusting gain after the A/D

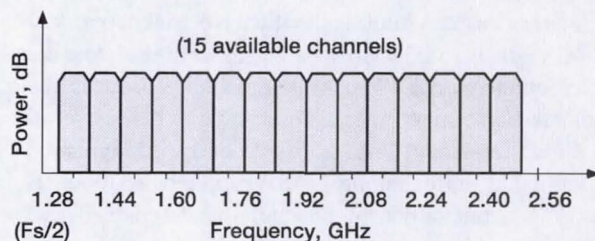

Fig. 1—Frequency plan.

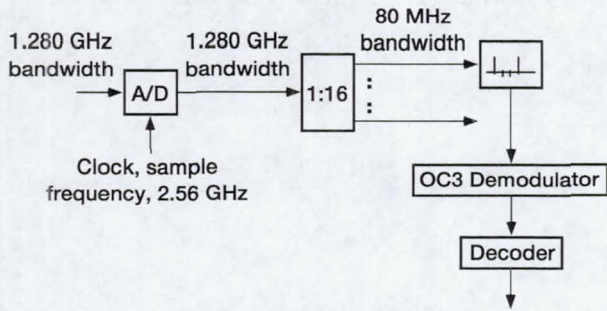

Fig. 2—Channelizer architecture.

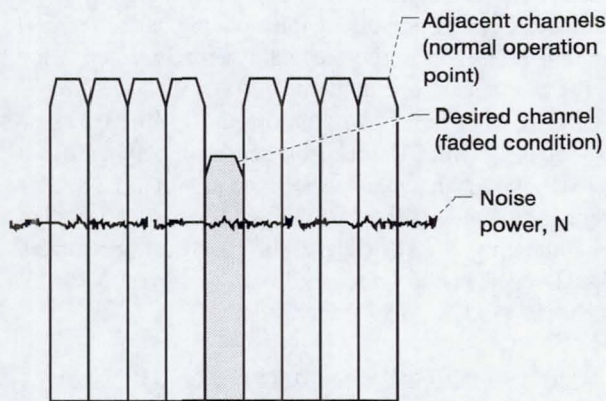

Fig. 3—Transmission characteristics.

conversion process via digital signal-processing techniques. The test equipment and the test plans must also be designed to accommodate this system scenario.

Test Set Configuration

The special test equipment generates 8-PSK modulated signals and stacks these communication channels in frequency to be passed through the E-Systems MCDD. The bit-error-rate (BER) of the signal received from the modem is then measured, thus characterizing both the demultiplexing and demodulation functions of the MCDD (Fig. 4).

The wideband signals are generated with three B-ISDN (Broadband Integrated Services Digital Network) modulators that can interface to the terrestrial network at the OC3 rate of 155.52 Mb/sec. The three modulators are implemented with $F_s/4$ sampling, which produces the modulated spectrum centered at one-quarter of the overall sampling frequency; NASA has recently implemented and validated this technique. NASA supplied two modulators to generate adjacent channel interference. These 8-PSK modulators use 20-percent raised cosine pulse shaping and a concatenated pragmatic rate 5/6 inner code

and Reed-Solomon (255,239) outer code. With this they obtain a spectral efficiency of approximately 2.5 b/sec/Hz and a bandwidth efficiency of 1.944 b/sec/Hz. The Raytheon 8-PSK modem uses 33-percent raised cosine pulse shaping and a Reed-Solomon (124,108) code with an additional bit per Reed-Solomon code word for framing and synchronization. This modem obtains a spectral efficiency of approximately 2.25 b/sec/Hz and a bandwidth efficiency of 1.944 b/sec/Hz.

Each wideband channel is upconverted to enable the three channels to be stacked over 240 to 480 MHz (Fig. 5). This upconversion creates an image approximately 50 MHz away from the desired signal (Fig. 6). Image rejection filters are necessary to eliminate such images and any extraneous signals caused by the upconversion process. Attenuators 1, 2, and 3 (actually each is an 11-dB attenuator and a switch) are used to adjust the signal power in each of the three channels. The switch is used to obtain full attenuation, whereas the 11-dB attenuators are used to make minor signal level adjustments. Ideally, each attenuator subsystem would consist of one 121-dB programmable attenuator; however, commercial off-the-shelf hardware was not available in VXI (Versa Module Europa bus eXtensions for Instrumentation) form. Attenuators 1 and 3 are adjusted for adjacent channel interference tests, and attenuator 2 is used to obtain E_b/N_0 (energy per information bit/normalized noise power) curves. Attenuators 1 and 3 are set for full attenuation during modem-only testing and are adjusted to create, in channels 1 and 3, interference signals ≤ 11 -dB greater than the signal power in channel 2 for combined modem/channelizer testing. The energy per symbol signal power (E_s) into the attenuator subsystems of channels 1, 2, and 3 are equal. Therefore, the signal power into the channel 2 attenuator subsystem has to be adjusted slightly to accommodate the variation in coding between the NASA-supplied modulators and the Raytheon modulator under test.

Once the three modulated channels are stacked, they are again upconverted to reside in the 1.28- to 2.56-GHz range and summed with the noise (Fig. 7). Notice that a mirror image of the summed signals results. Any images that occur as a result of the upconversion process must be accounted for in calibration, but they do not affect testing and characterization. In fact, the images are simply perceived as additional channels. With the local oscillator, LO4, the channel under test can be moved into various 80-MHz bins.

Other attenuators are used as follows: Attenuator 4 adjusts the noise floor relative to the modulated signals; attenuator 5, which consists of concatenated 11-dB and 70-dB attenuators, provides 81-dB overall attenuation and adjusts the total power into the MCDD, the A/D converter loading.

- ATTN Attenuator
- BER Bit error rate
- LO Local oscillator
- MCCD Multichannel demultiplexer/demodulator
- MOD Modulator
- OC3 Optical carrier 3
- Computer controlled

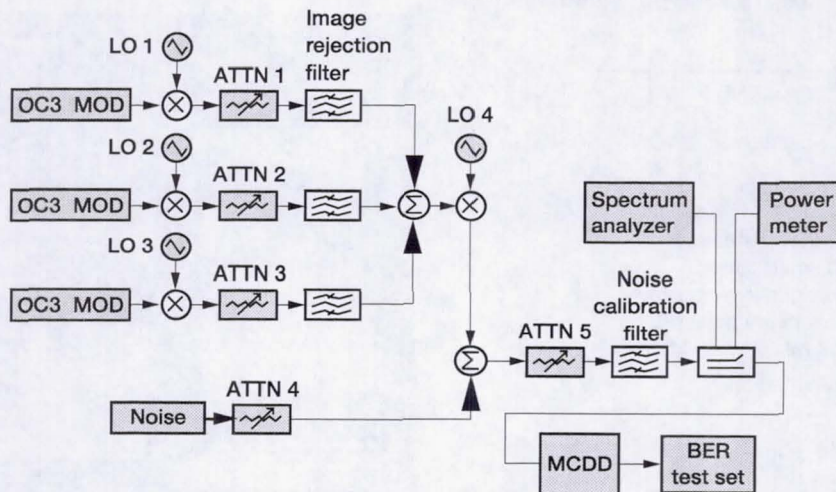

Fig. 4—Block diagram of special test equipment.

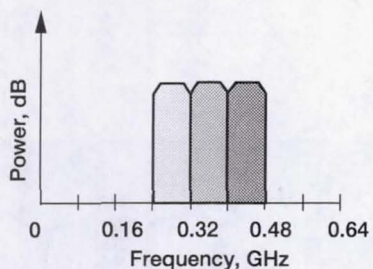
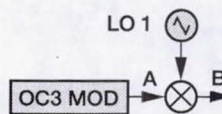

Fig. 5—B-ISDN channel stacking.



Example: 60 Mega samples/sec,
direct IF generation

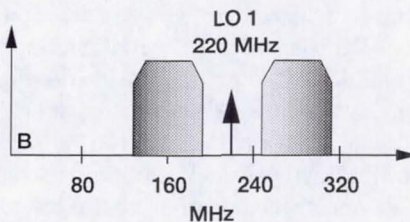
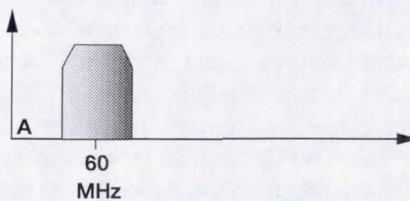
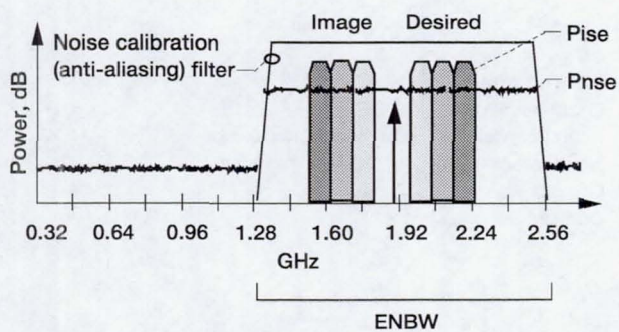

Fig. 6—Image creation.



$$Eb/No = [Pise/(Rb \times chs)]/(Pnse/ENBW)$$

- Chs Number of channels
- Eb Energy/bit
- ENBW Energy noise power bandwidth
- No Normalized noise power
- Pise Information signal energy power
- Pnse Noise signal energy power
- Rb Uncoded bit rate (155.52 Mb/sec)

Fig. 7—Calibration.

The noise calibration filter acts as an anti-aliasing filter, limiting the noise into the A/D converter and providing an accurate, calibrated noise bandwidth from which a normalized noise power can be determined.

Hardware and Test Equipment

In order to reduce costs, complete the test set in a timely fashion, and build a modem/channelizer test set that would be easily reconfigurable for applications other than the specific modem/channelizer testing required under the Millennium program, existing equipment already possessed by NASA, or purchased, commercially available off-the-shelf equipment was used as much as possible. The test system is completely automated to enable expedient, reliable, reproducible tests. In addition, signals are coupled off to the power meter and spectrum analyzer to permit continuous monitoring and to eliminate the need to remove connections during calibration or debugging. All equipment is computer controlled by a general purpose interface bus, a VXI bus, or RS-232 serial interfaces. All system clocks and local oscillators are provided via digitally synthesized signal generators. All attenuators and switches are provided via VXI cards. The NASA-supplied modulators and the Raytheon modulator reside in the VXI chassis. The Raytheon modulator is controlled via the VXI bus, and the NASA-supplied modems, via an RS-232 port located on the front of the card. Two custom RF

(radiofrequency) cards were fabricated on VXI blank panels. The equipment rack, the RF card that performs the channel stacking, and the RF card that performs both the upconversion to 1.28 to 2.56 GHz and the noise summation are shown in Figs. 8 to 10, respectively.

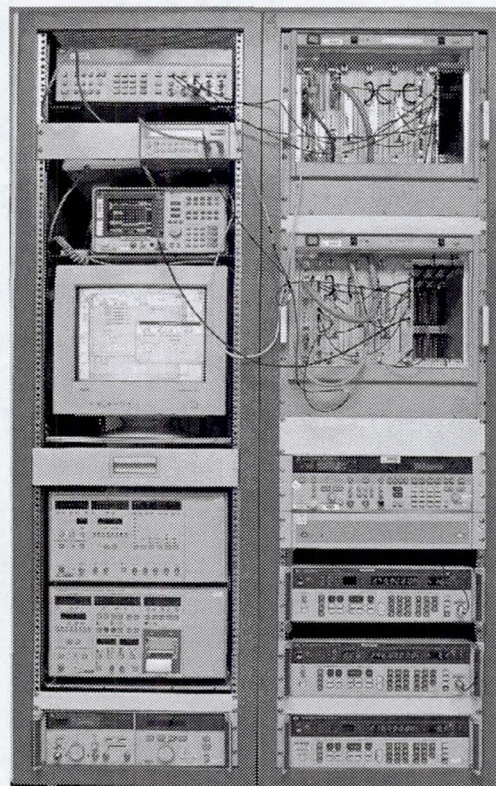

Fig. 8—Special test equipment.

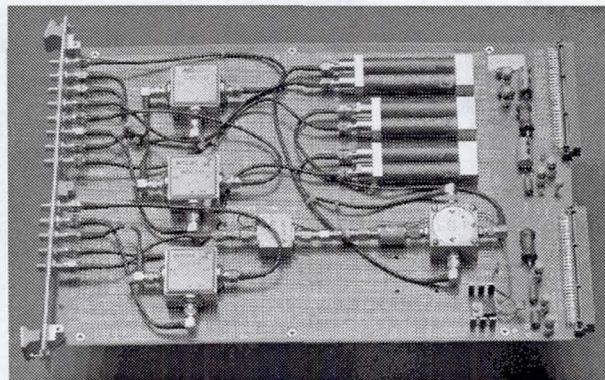

Fig. 9—Channel stacking RF card.

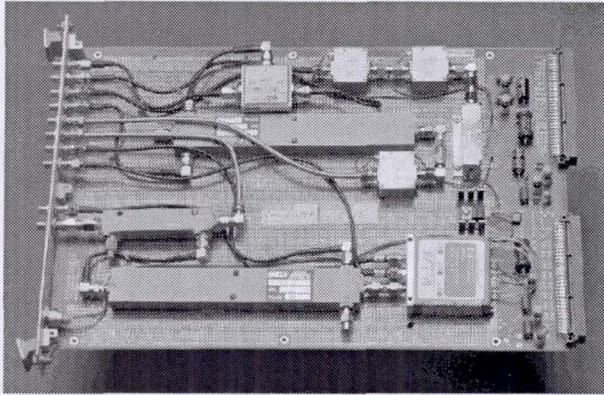

Fig. 10—Upconversion and noise generation RF card.

Software

All instrumentation-controlling software was written with National Instruments LabView,[®] a graphical programming software language. This language was chosen for the following reasons: ease of use; the vast number of existing instrument drivers, and the nearly self-documenting characteristics of the graphical programming language. In addition, the Virtual Instrument Software Architecture (VISA) instrumentation routines make error

handling uniform and relatively easy to accomplish. The special test equipment will reside in a number of locations across the country and different users will constantly be integrating additional equipment into the system; thus error handling is of utmost importance for quickly locating unconnected cabling, changed instrument addresses, and inadvertently powered-down equipment.

The main program initializes all equipment to a fail-safe mode; then it remains in a software loop awaiting operator input. There are three main test routines, three documentation routines, and one status routine. Figure 11 shows the front panel of the main program.

Test Routines

The three test routines are *Configure Test*, *Calibrate*, or *Run Test*.

The *Configure Test* routine allows one to set up new test parameters or recall an existing test configuration. The test configuration parameters are *force calibration* (force or auto calibrate), *test mode* (MCDD or modem-only), *A/D set point*, *maximum Ebi/No*, and the *test inputs*. The *test mode*, *maximum Ebi/No* and *A/D set point* are input parameters to the calibration routine and determine the noise floor.

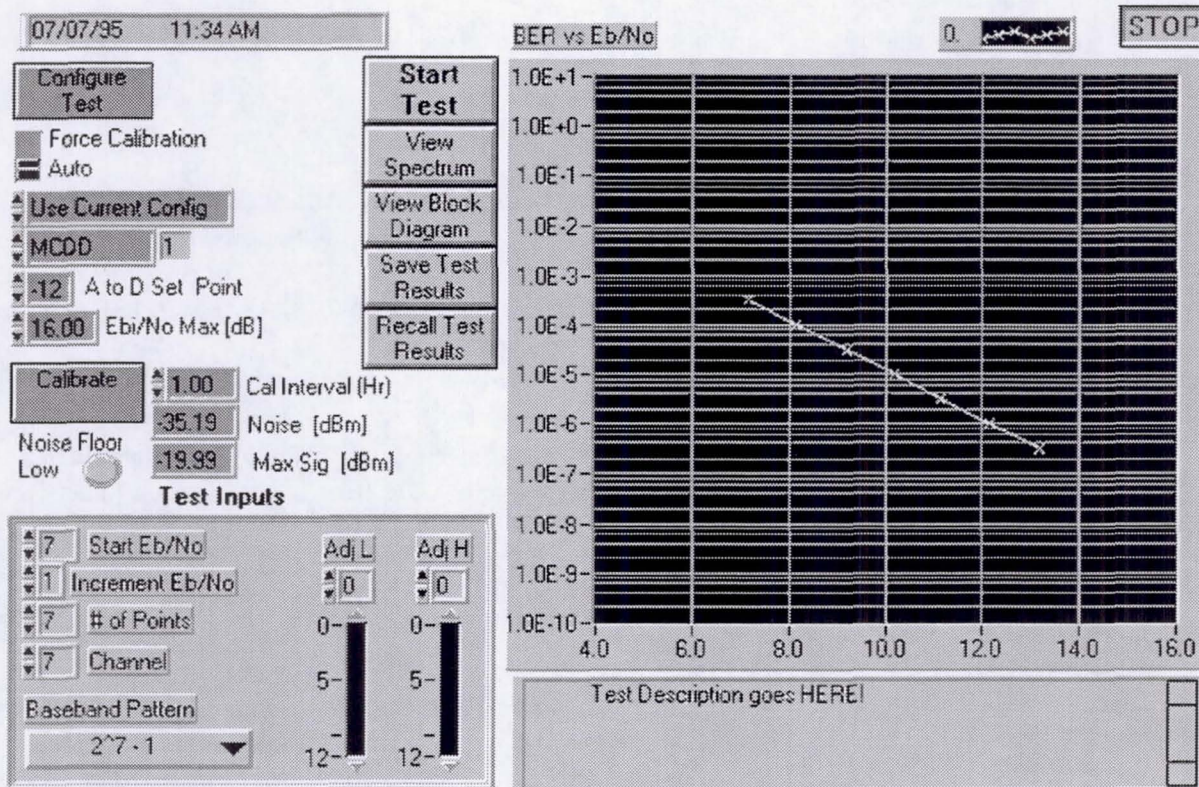

Fig. 11—Main panel.

The *Calibrate* routine initiates system calibration. First, the power meter is zeroed and calibrated. Second, the E_s/No (energy per symbol/normalized noise power) for each channel is adjusted to be equal for all channels. This is done by taking advantage of the mixer conversion loss. The mixer can be made to act as a programmable attenuator by adjusting the LO power into the mixer. Next, the noise power and maximum signal power are determined by using the *test mode*, *A/D set point*, and *Ebi/No* as input parameters (see Fig. 12). If the thermal noise floor falls below the A/D noise floor, a warning indicator is activated on the front panel. Next, the 81-dB attenuator, attenuator 5, is adjusted for maximum signal power. After this, the noise attenuator, attenuator 4, is adjusted for proper noise levels, and the signal attenuators are stepped through to determine the Ebi/No for each attenuator setting. The *calibration interval* input is used to force calibration after the time interval specified, whether or not the *force calibration* software switch is set. The calibration routine runs only when one of the following conditions are met: the *force calibration* switch is selected, the *calibration interval time* has been exceeded, or one of the three test input parameters (*test mode*, *A/D set point*, or *maximum Ebi/No*) has been changed since the last calibration. This forces calibration to be up-to-date and allows a number of tests to be run without recalibrating, if recalibration is not necessary.

The *Run Test* routine is all encompassing. First the *Configure Test* routine is executed to see what options to use: *current configuration*, *recall an existing configuration*, or *create a new test configuration*. Next, the *Calibrate* routine is executed and recalibration occurs if necessary. Finally, the BER test is run. The test input choices are the *starting Ebi/No*, the *Ebi/No increment* between points, the *number of points* to be plotted, the *channel* to be tested, the *pseudorandom baseband pattern* to be used, and the *adjacent channel* interference levels.

Documentation Routines

The three documentation routines are *Save Test Results*, *Recall Test Results*, and *View Spectrum*.

The *Save Test Results* routine saves the following information to a file specified by the operator: the date and time, a short test description, all test configuration input parameters, the Ebi/No data points, the Ebi/No attenuator settings, and the local oscillator settings.

The *Recall Test Results* routine reads a file of saved test results and restores the following information to the main panel for plotting or display purposes: the date and time, the test description, all test configuration input parameters, and the Ebi/No data points. The Ebi/No attenuator settings and the local oscillator settings are not recalled because

INPUTS		OUTPUTS	
MCDD	MCDD/Modem	0.400000	Prms max [mW]
400	Vpp max [mV]	-3.979400	Prms max [dBm]
-12	A to D Set Point [dB]	0.251189	A to D Set Point
17.80	Ebi/No Max Oper Pt [dB]	0.025238	P set pt max [mW]
6.00	Fade Margin [dB]	-15.979400	P set pt max [dBm]
11.8	Ebi1/No Min Oper Point [dB]	0.00155280	Power Type 1 Ch [mW]
3	Bits per Symbol	0.00171772	Power Type 2 Ch [mW]
2	# Type 1 Chs	0.02543600	Power Total Signal [mW]
13	# Type 2 Chs	0.00019925	Power Total Noise [mW]
1.157407407	Type 1 Coding + Overhead	-37.005947	Power Total Noise [dBm]
1.280334728	Type 2 Coding + Overhead	1.660443E-13	No [mW/Hz]
1200000000	ENBW [Hz]	-47.415947	PM Noise Meas [dBm]
155200000	Rbi1 [Hz]	2.59334E-11	Es1 [mW]
155200000	Rbi2 [Hz]	2.59334E-11	Es2 [mW]
-38.38	Noise Floor Min [dB]	1.00052E-11	Ebi1 [mW]
10.41	Coupler/Spitter Loss [dB]	17.800000	Ebi1/No [dBm]
4.0	Ebi1/No Min Setting [dB]	1.10678E-11	Ebi2 [mW]
		156.183445	Es1/No
		21.936350	Es1/No [dBm]
		0.00937649	Power for WB Cal [mW]
		-20.010221	Power for WB Cal [dBm]
		1200000000	ENBW [Hz]
		-30.420221	PM Meas Max Set [dBm]
		155200000	Rbi1 [Hz]
		-33.810221	Pwr Cal Min Set [dBm]
	<input checked="" type="checkbox"/> Noise Floor Low [T]	10.41	Coupler/Spitter Loss [dB]

Fig. 12—Calibration subroutine spreadsheet.

these settings are determined during calibration and may no longer be valid.

The *View Spectrum* routine allows the operator to control the spectrum analyzer via the computer and to print the spectrum analyzer screen for documentation purposes.

The *View Block Diagram* routine allows the operator to easily obtain the status of various switches, attenuators, and local oscillators. When *View Block Diagram* is executed, a system block diagram similar to Fig. 4 is shown on the computer monitor along with a status for each subsystem.

Calibration and Testing

Calibration

Calibration is the most critical part of accurate testing and characterization. Calibration is necessary to determine the proper modulation-signal and noise-signal attenuator settings for each desired E_b/N_0 measurement. Poor calibration leads to errors and misperceptions in the results that indicate either superior or inferior performance. For this reason, the system was developed to provide automated, accurate, reproducible calibration.

Figure 7 depicts the calibration concept and the theoretical equation for E_b/N_0 . Note: The information bit rate (i.e., uncoded bit rate) and the transmission bit rate vary by the coding rate for coded systems. The BER curves are generated relative to the information bit rate (155.52 Mb/sec for OC3) rather than the transmitted bit rate. Because of the way signals are stacked and then upconverted, six OC3 channels are available for calibration purposes—three original and three images—even though there are only three OC3 modulators. Since the NASA modulators utilize a slightly different coding scheme than the Raytheon modulator, the E_s/N_0 levels are held equal in all channels in order to provide meaningful adjacent channel interference measurements. The hardware and calibration procedure are designed to compensate for this. Also, the LO feedthrough power from LO4 is measured and compensated for during calibration.

The maximum E_b/N_0 , A/D set point, transmission bit rate, code rates, effective noise bandwidth (ENBW), and test mode are only a few of the many parameters that must be considered to determine the maximum signal power and noise floor power for calibration. A subroutine,

representing a spreadsheet, was developed to aid in calculating the noise power and calibration signal power for various A/D loading and fade margins for modem-only and MCDD characterization (Fig. 12).

Testing

The modem/channelizer test system provides the capability to perform modem-only characterization as well as combined modem/channelizer testing. The modem can be characterized in any of the 15 available channels, with and without adjacent channel interferers. In addition, the A/D set point may be varied for dynamic range testing.

One limitation of the test system is that two channels exist for modem-only testing, the desired channel and its image (unless the channel under test is at the lower portion of the frequency bins where the anti-aliasing filter removes the undesired image). For modem-only testing, the image channel should be sufficiently spectrally removed from the desired channel so as to have little effect, except to decrease the dynamic range by 3 dB, since the A/D set point must account for both the desired and image signals being present.

A second limitation is that in frequency offset testing the image rejection filters in each modulator channel may filter much of the adjacent channel interference caused by the frequency offset. The purpose of the offset test is to determine how closely the modulator carrier frequency must be controlled, by offsetting the interfering channel(s), so that they begin to move into the desired channel. Although somewhat limited, this test is relatively easy to perform with the available equipment and should provide additional information about the performance of the channelizer and demodulators.

Concluding Remarks

A broadband modem/channelizer test set has been developed by NASA Lewis Research Center. The test set is a fully programmable, BER test set for broadband modem-only and multichannel demultiplexer/demodulator characterization. The test set is currently configured for testing a multichannel demultiplexer/demodulator developed for the Advanced Research and Projects Agency under the Technology Reinvestment Program. The test set can easily be modified to provide testing of other modems and multichannel demultiplexer/demodulator systems and is available to industry for such testing.

REPORT DOCUMENTATION PAGE

Form Approved
OMB No. 0704-0188

Public reporting burden for this collection of information is estimated to average 1 hour per response, including the time for reviewing instructions, searching existing data sources, gathering and maintaining the data needed, and completing and reviewing the collection of information. Send comments regarding this burden estimate or any other aspect of this collection of information, including suggestions for reducing this burden, to Washington Headquarters Services, Directorate for Information Operations and Reports, 1215 Jefferson Davis Highway, Suite 1204, Arlington, VA 22202-4302, and to the Office of Management and Budget, Paperwork Reduction Project (0704-0188), Washington, DC 20503.

1. AGENCY USE ONLY (Leave blank)	2. REPORT DATE November 1995	3. REPORT TYPE AND DATES COVERED Technical Memorandum	
4. TITLE AND SUBTITLE Millennium Modem/Channelizer Special Test Equipment		5. FUNDING NUMBERS WU-235-01-40	
6. AUTHOR(S) William D. Ivancic		7. PERFORMING ORGANIZATION NAME(S) AND ADDRESS(ES) National Aeronautics and Space Administration Lewis Research Center Cleveland, Ohio 44135-3191	
8. PERFORMING ORGANIZATION REPORT NUMBER E-9974		9. SPONSORING/MONITORING AGENCY NAME(S) AND ADDRESS(ES) National Aeronautics and Space Administration Washington, D.C. 20546-0001	
10. SPONSORING/MONITORING AGENCY REPORT NUMBER NASA TM-107096 AIAA-96-1150		11. SUPPLEMENTARY NOTES Prepared for the 16th International Communications Satellite Systems Conference, sponsored by the American Institute of Aeronautics and Astronautics, Washington, DC, February 25-29, 1996. Responsible person, William D. Ivancic, organization code 5650, (216) 433-3494.	
12a. DISTRIBUTION/AVAILABILITY STATEMENT Unclassified - Unlimited Subject Category 17 This publication is available from the NASA Center for Aerospace Information, (301) 621-0390.		12b. DISTRIBUTION CODE	
13. ABSTRACT (Maximum 200 words) A broadband modem/channelizer test set developed by NASA Lewis Research Center is discussed. The test set is a fully programmable, bit-error-rate (BER) test set designed for broadband modem-only and multichannel demultiplexer/demodulator characterization. It is currently configured for testing a multichannel demultiplexer/demodulator and was developed for the Advanced Research and Projects Agency under a Technology Reinvestment Program Cooperative Agreement entitled "Millennium: 21st Century Broadband Digital Telecommunications Technology." The test set can easily be modified to provide testing of other modems and multichannel demultiplexer/demodulator systems and is available to industry for such testing.			
14. SUBJECT TERMS Modems; Channelizer		15. NUMBER OF PAGES 9	
		16. PRICE CODE A02	
17. SECURITY CLASSIFICATION OF REPORT Unclassified	18. SECURITY CLASSIFICATION OF THIS PAGE Unclassified	19. SECURITY CLASSIFICATION OF ABSTRACT Unclassified	20. LIMITATION OF ABSTRACT