

Evolution of the Revolutionary Blended-Wing-Body

BWB

Robert H. Liebeck
Mark A. Page
Blaine K. Rawdon

McDonnell Douglas Aerospace
Long Beach California

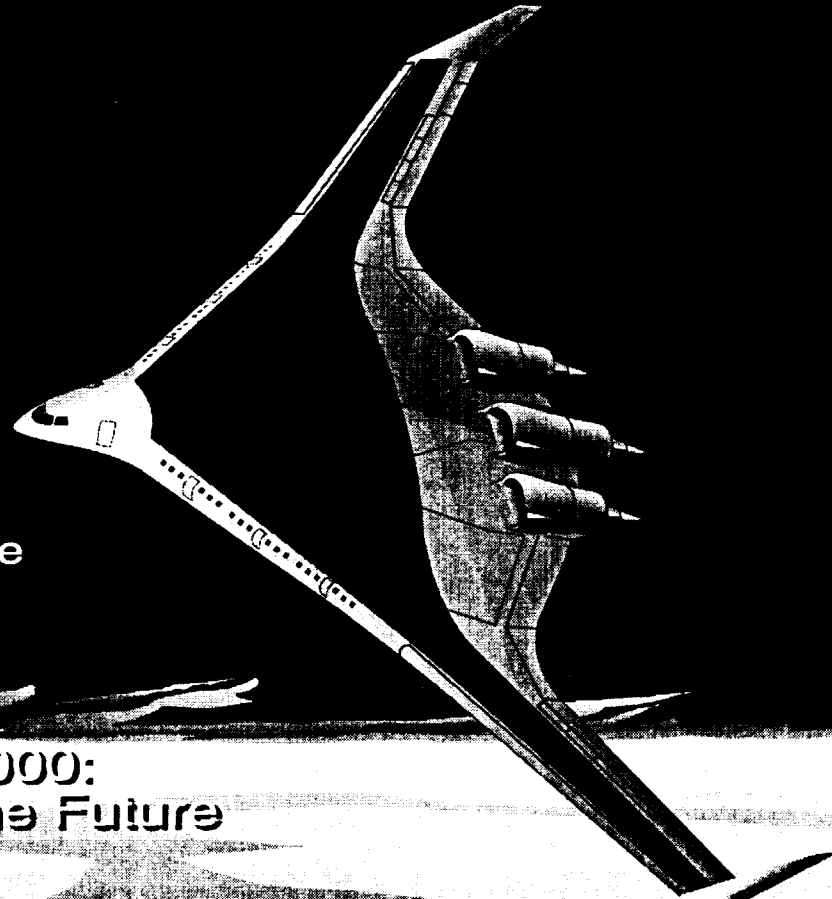

Transportation Beyond 2000:
Engineering Design for the Future

NASA Langley Research Center, September 26-28, 1995

2000
1995

NASA Question.....

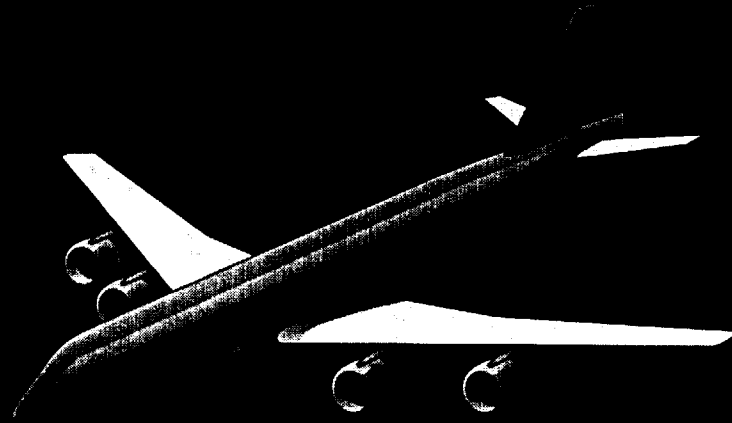

Is There an Aerodynamic Renaissance for the Long-Haul Transport?

- Dennis Bushnell, December 1988

McDonnell Douglas

Transport Evolution; the First and Second 43 Years

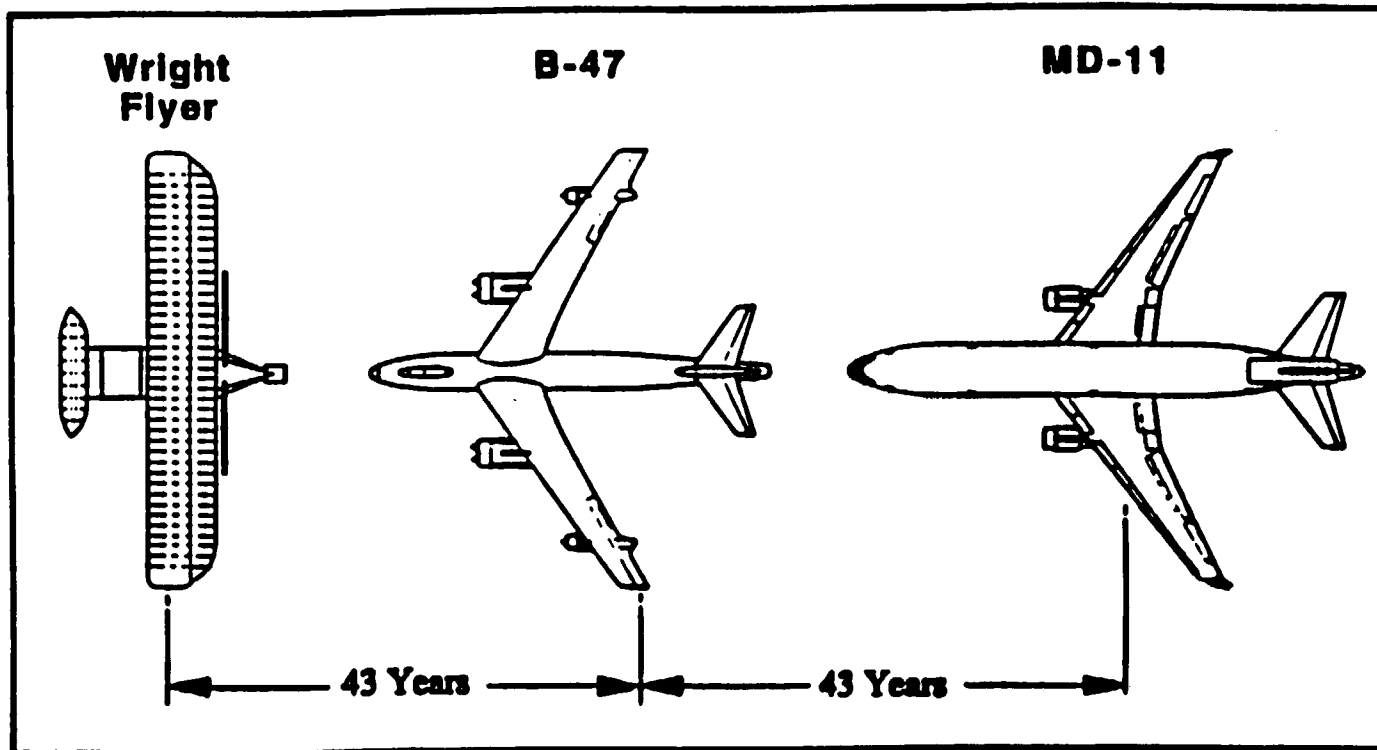

McDonnell Douglas

AERODYNAMIC EFFICIENCY EVOLUTION OF LONG HAUL COMMERCIAL TRANSPORTS

RANGE ≥ 4500 N MI

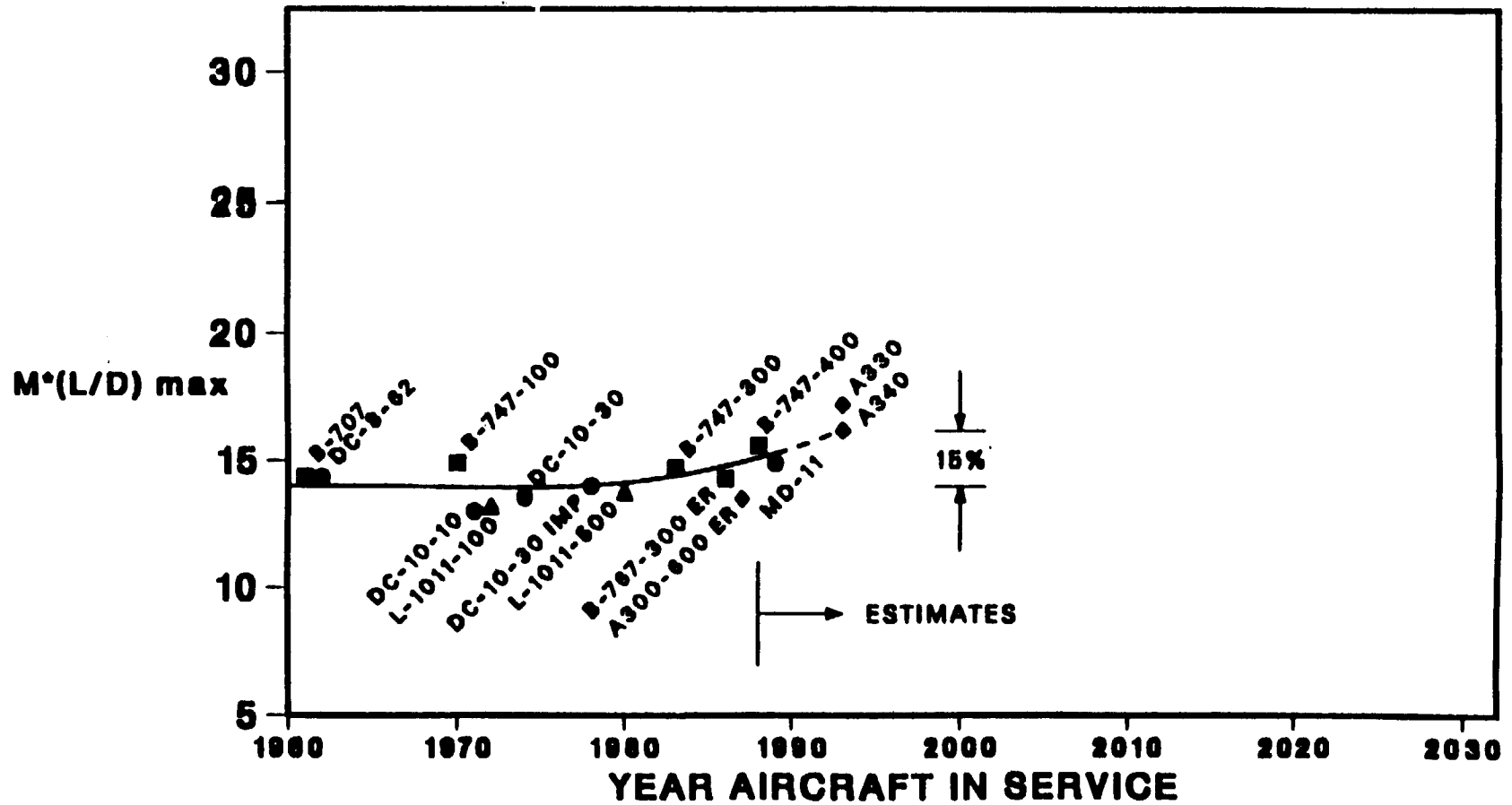

First Generation BWB

368 Passengers
8,500 nmi Range

Wing AR = 15.0
Wing Area = 4,500 sq-ft
Wingspan = 259.8 ft
Length = 167 ft

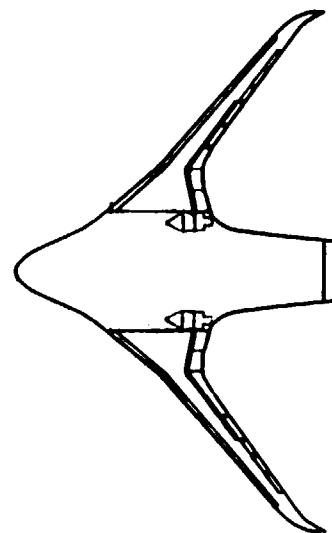

McDonnell Douglas

BWB Mission

800 Passengers, 3-class

7,000 nmi Range

$M_{crz} = 0.85$, 35,000 ft min ICA

11,000 ft TOFL

150 Kt Approach Speed

2015 Technology Level

2020 Entry Into Service

ADP Engine Technology

Stitched RFI Structures

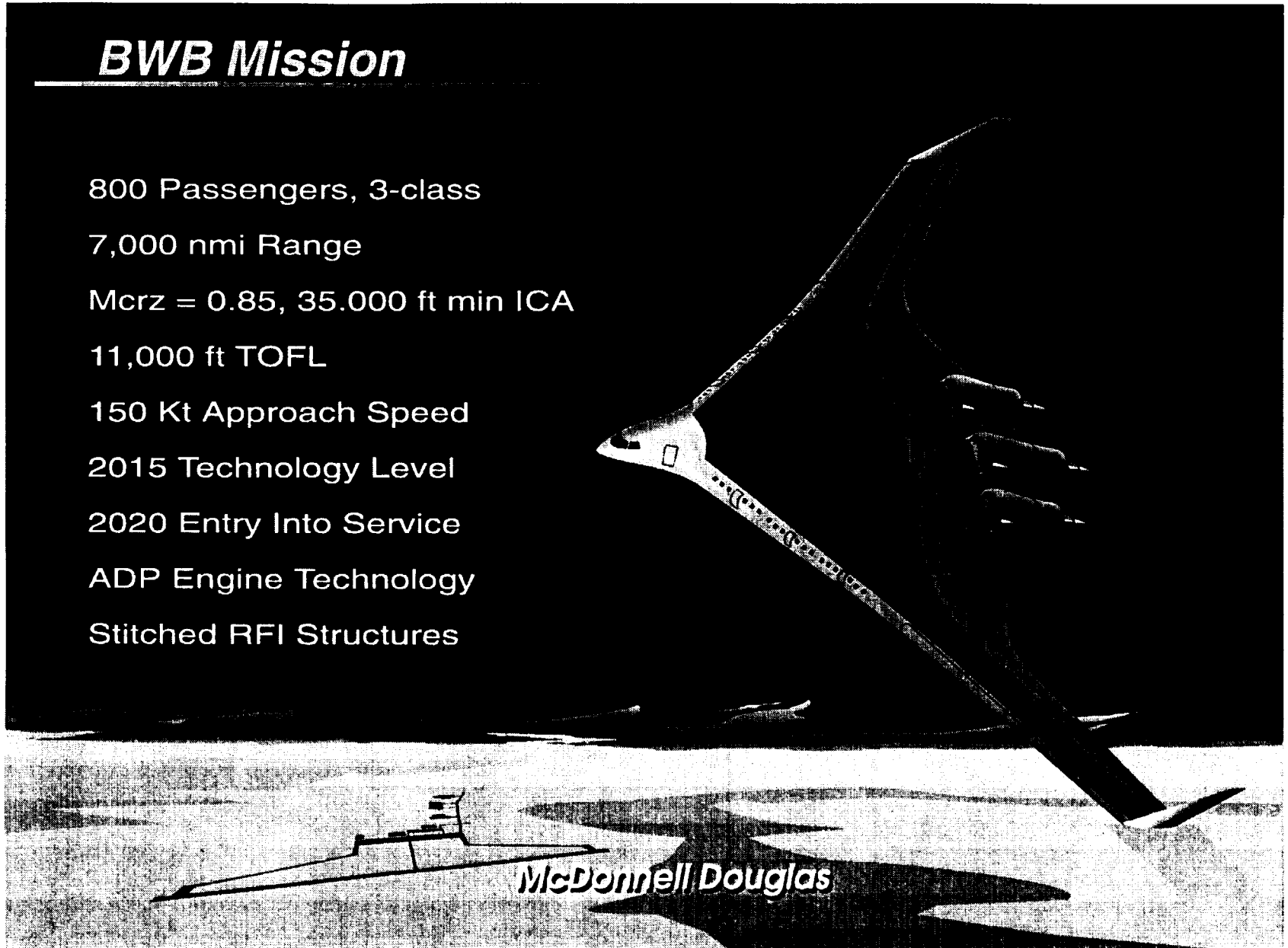

McDonnell Douglas

CONVENTIONAL

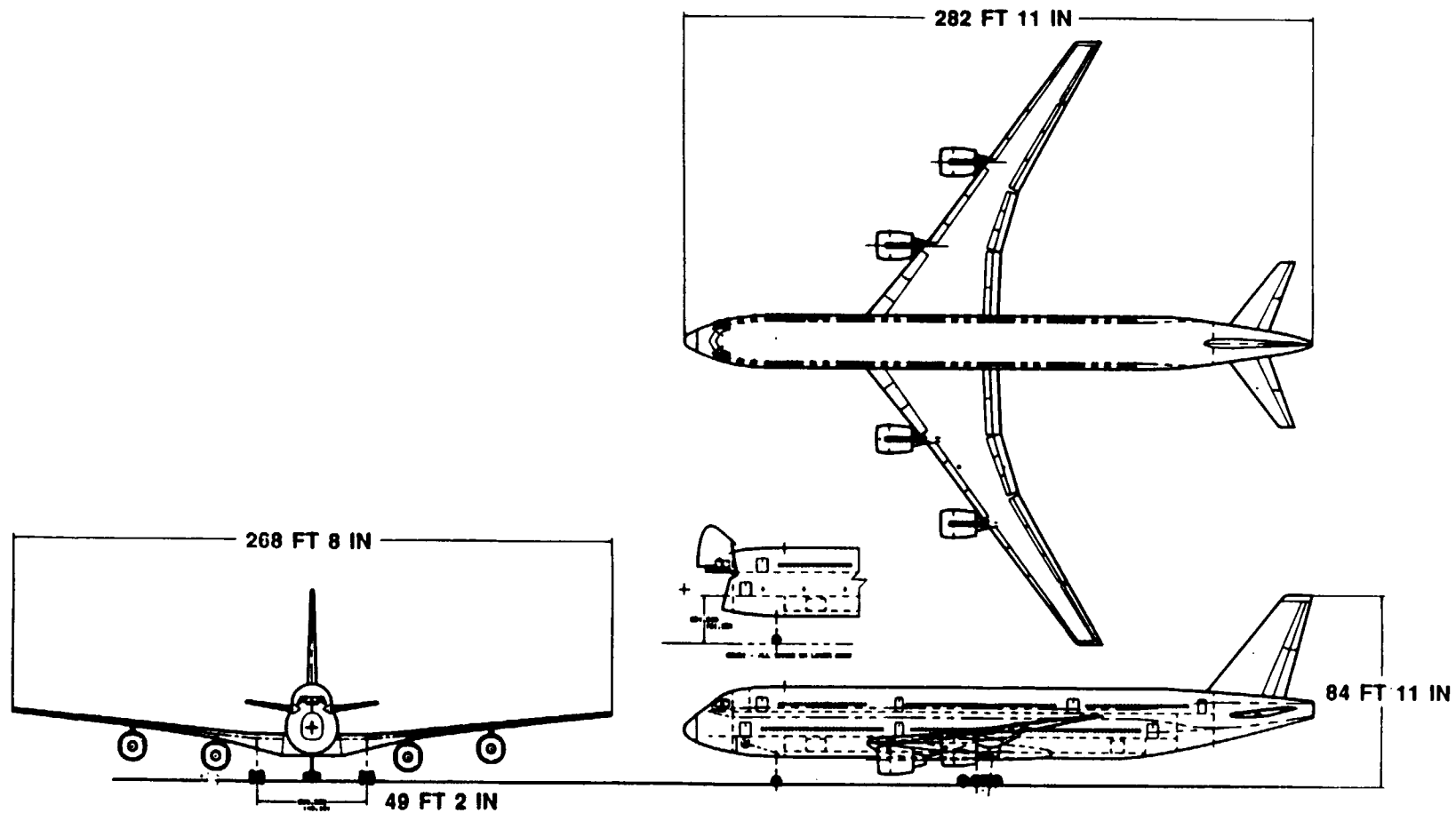

McDonnell Douglas

BLENDING WING - FIRST ITERATION

CROSS SECTION - 25 SEATS PER ROW

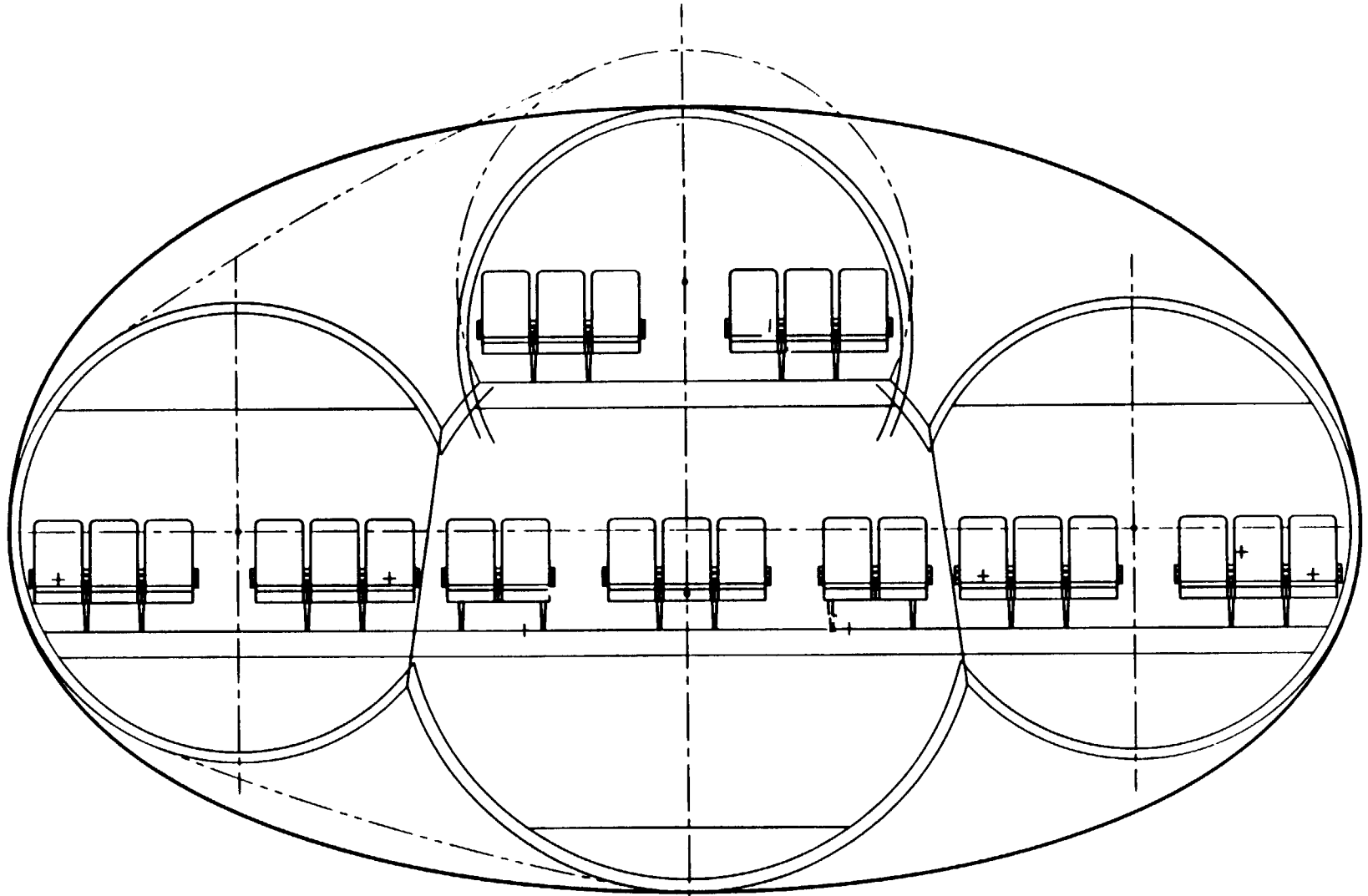

McDonnell Douglas

BLENDING WING - FIRST ITERATION

ISOMETRIC

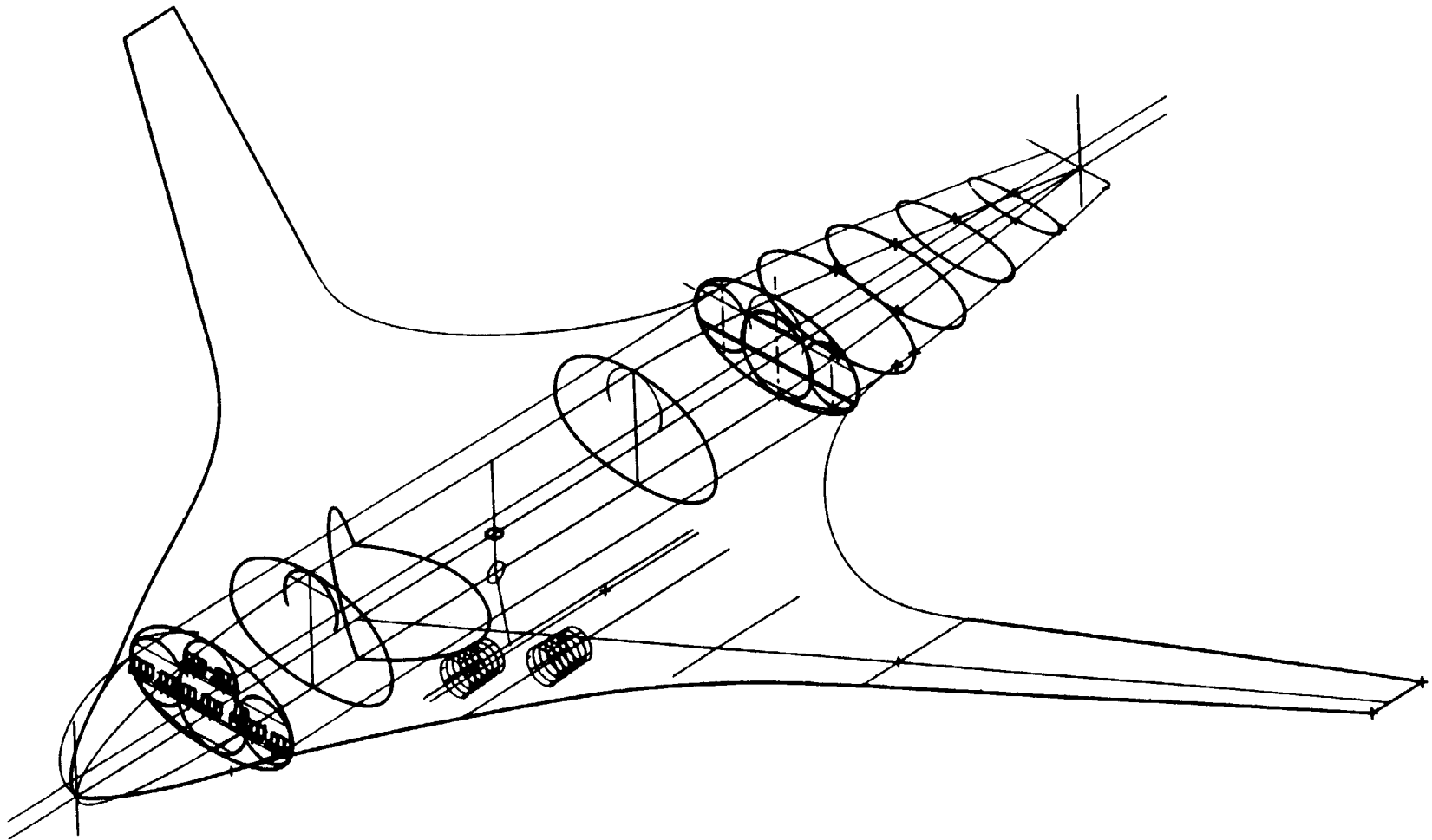

First Principles

"Man is the measure of all things" ... Leonardo Da Vinci

Effect of Passenger Count:

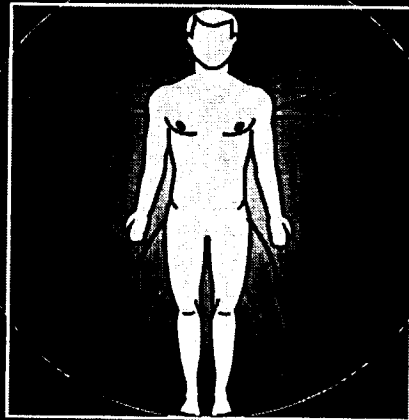

- Passenger height is discrete, not rubber.
- Passengers can stand in very large wings only.
- Passengers in the wing doesn't win until there are 2 decks.

McDonnell Douglas

First Principles

Cabin Packaging Constraints:

- 800 Passengers & Bags
- 10 square feet per passenger
- 82 inch minimum cabin height

McDonnell Douglas

First Principles

Means of Reducing Drag:

- Vortex Drag
- Friction Drag
- Separation Drag
- Compressibility Drag
- Maximize wingspan
- Minimize surface area
- Streamlined shapes
- Minimize thickness & lift

Effect of Body Type

Minimum Surface Area

Streamlined Options

Surface Area

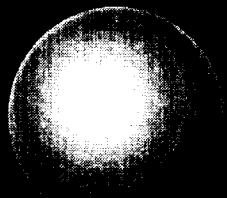

7,000 sq-ft

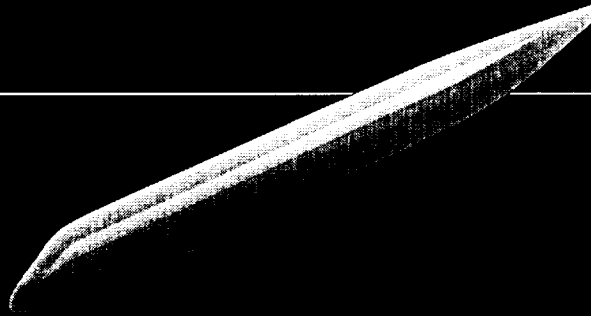

23,000 sq-ft

-4%

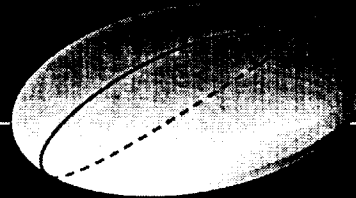

22,000 sq-ft

McDonnell Douglas

Effect of Wing/Body Integration

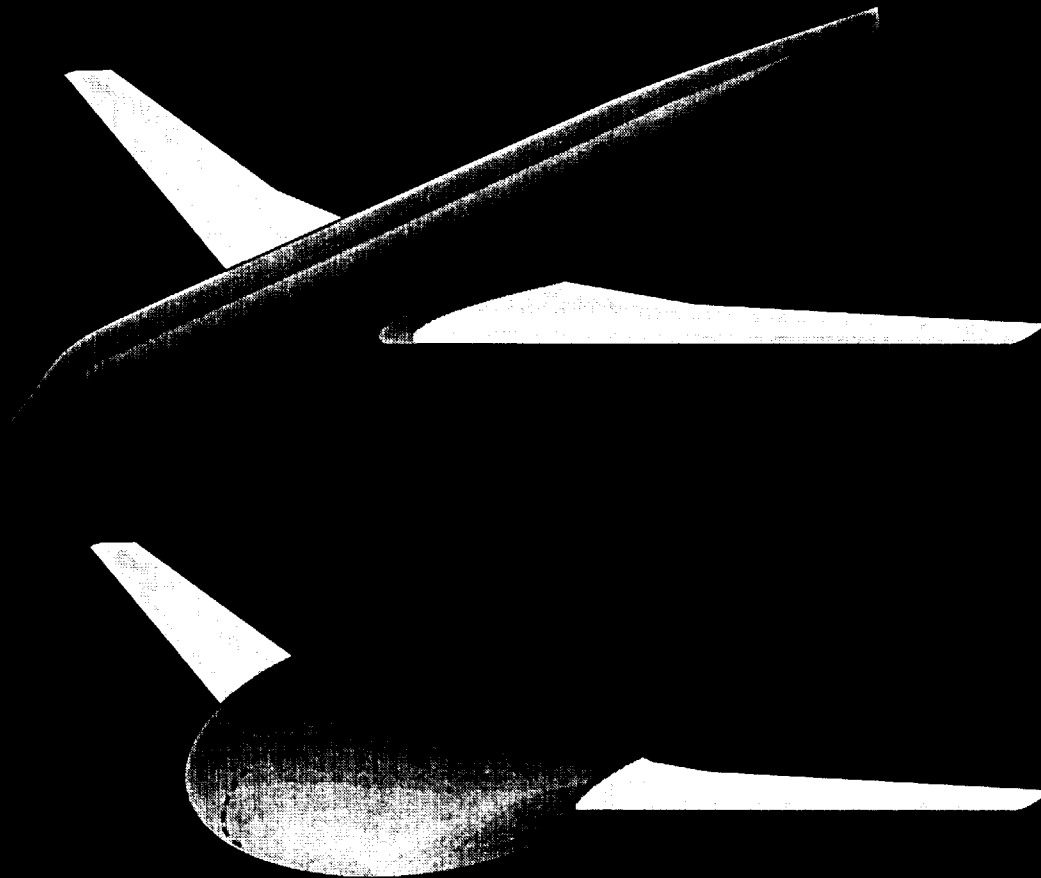

Surface Area

35,000 sq-ft

-20%

28,000 sq-ft

McDonnell Douglas

Effect of Engine Installation

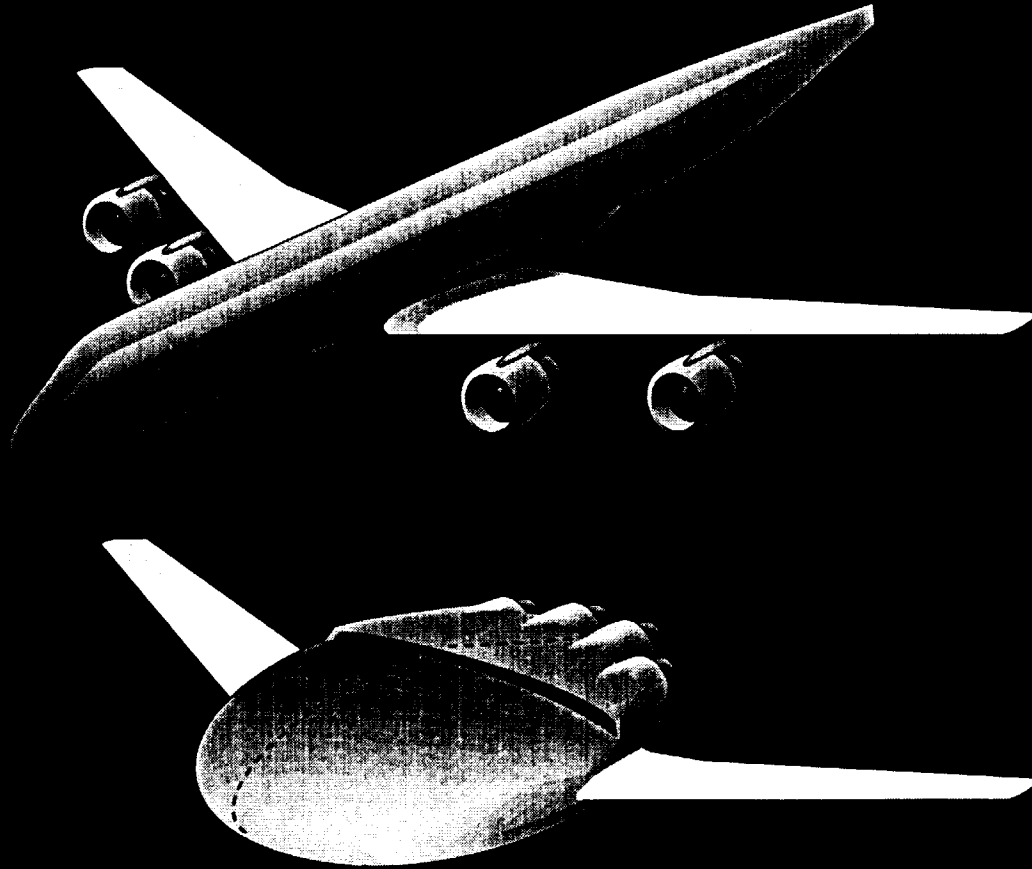

Surface Area

39,000 sq-ft

-25%

29,200 sq-ft

McDonnell Douglas

Effect of Controls Integration

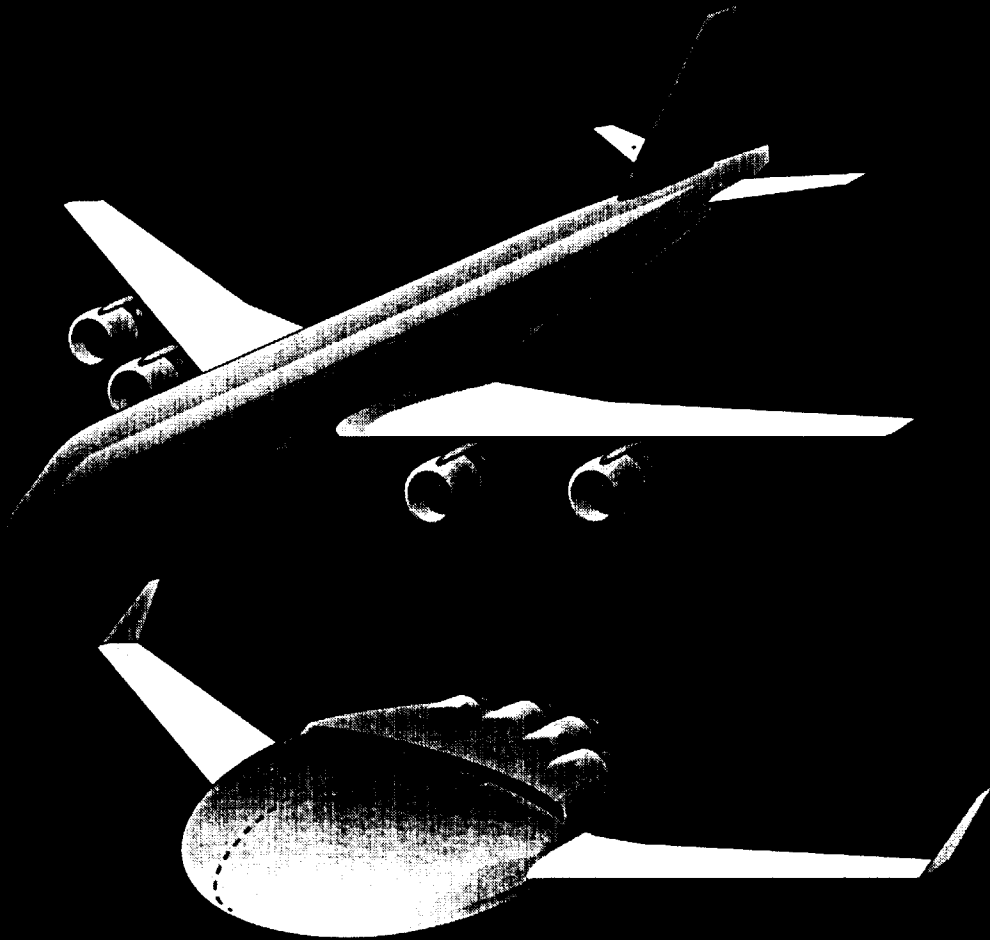

Surface Area

44,000 sq-ft

↓
-33%

↓
29,700 sq-ft

McDonnell Douglas

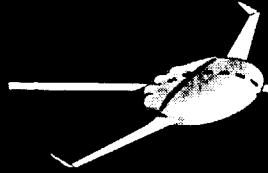

Current BWB Configuration

High Power Drag Rudders

Pitch & Roll Controls

3 ADP Engines

Direct Lift Controls

Speed Brakes

Fast Acting Rudders

Blended Wing Junction

Cockpit Bullet

Straight Leading Edge

Outboard Slats

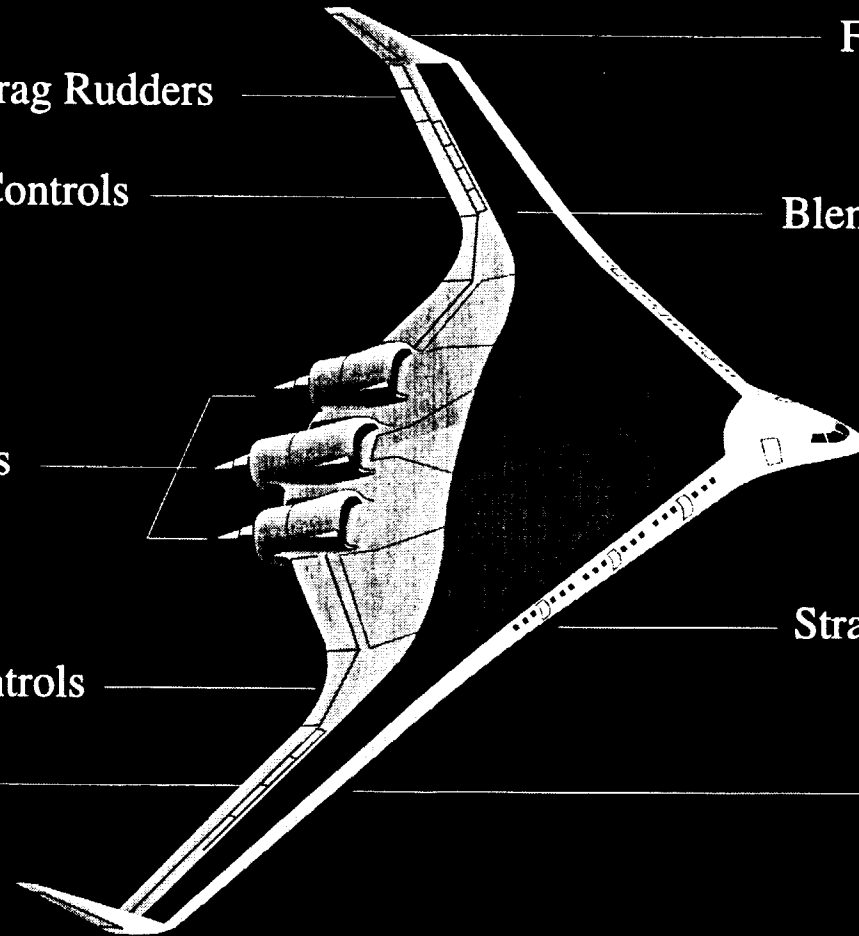

McDonnell Douglas

Alternate Engine Installation Study

Pod & Pylon

Upper S-Bend

Lower S-Bend

Over/Under

Mid Bifurcated

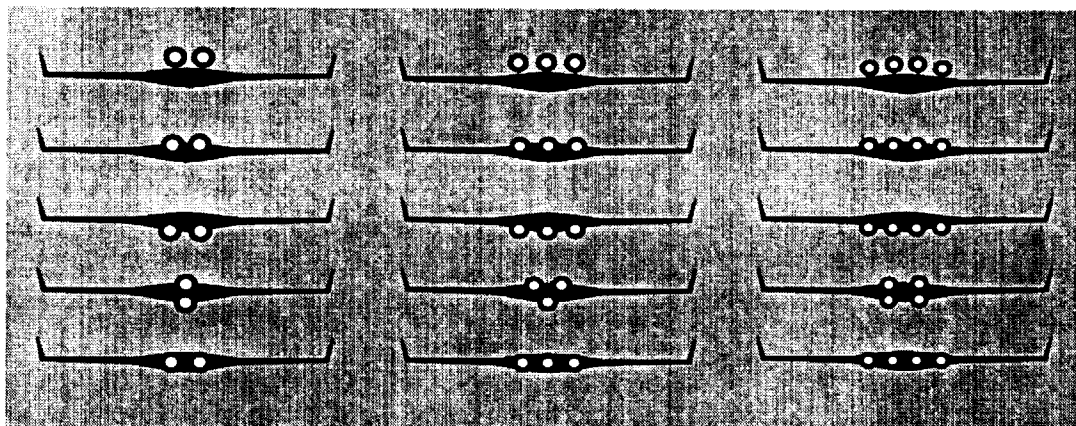

2-Engines

3-Engines

4-Engines

McDonnell Douglas

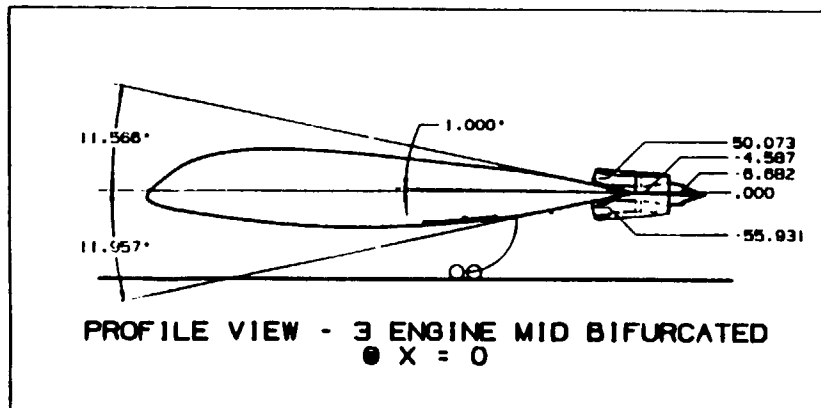
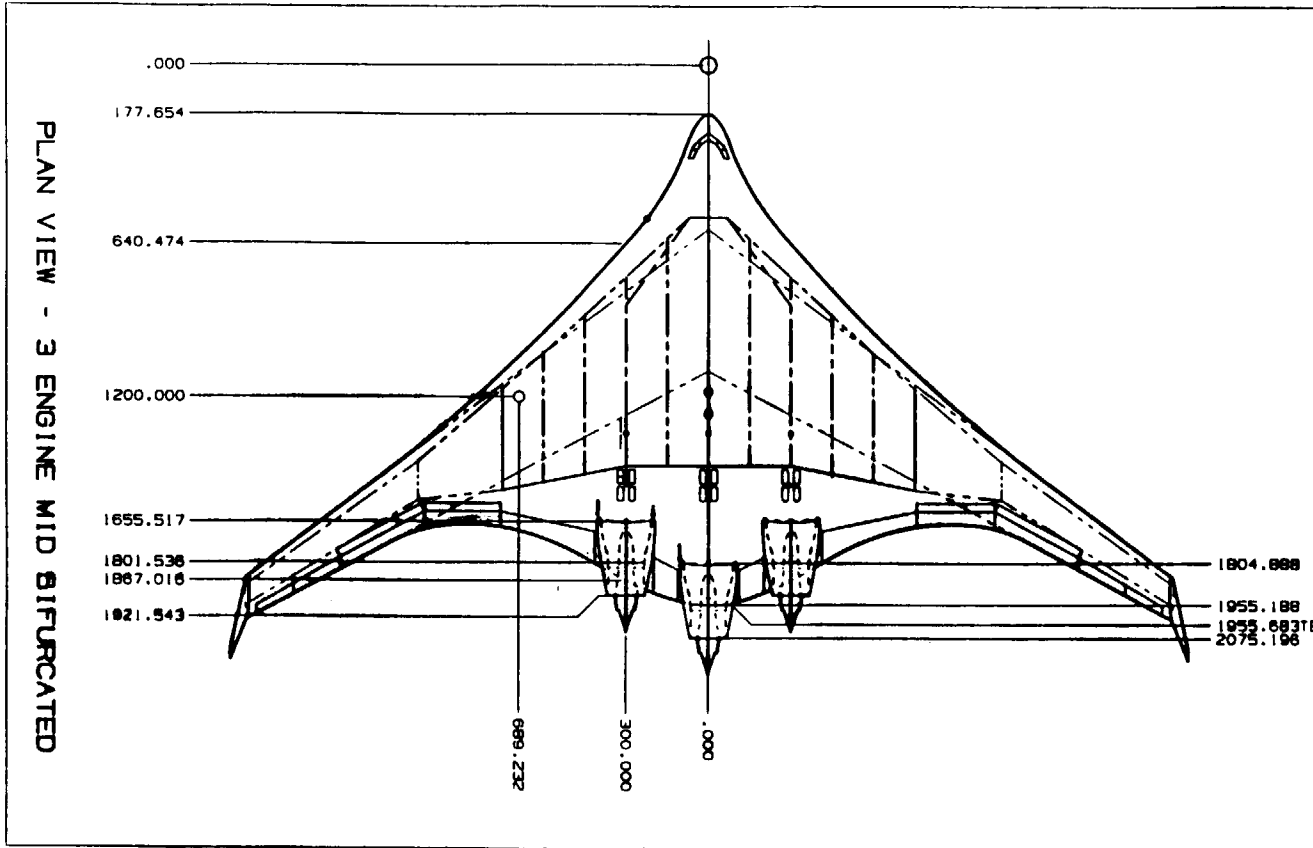

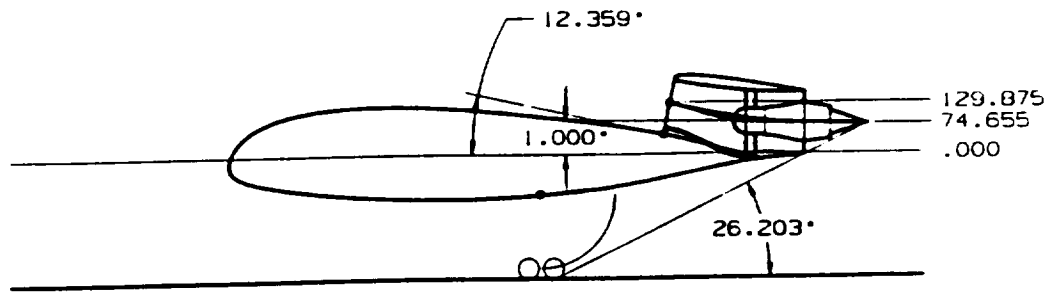

PROFILE VIEW - 2 ENGINE OVER
 ● X = 225

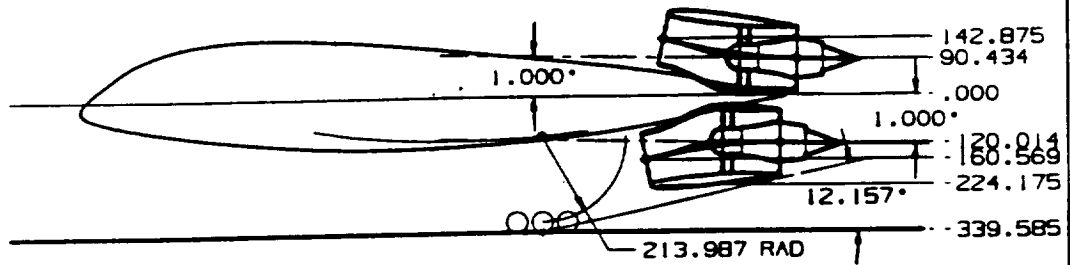

PROFILE VIEW - 2 ENGINE VERTICAL
 ● X = 0

Cabin Arrangement Study

- Cabin Design Issues:
- Door & aisle height
 - Airfoil wrapping
 - Cabin loading & emergency egress
 - Leading edge sweep
 - Continuous aft pressure bulkhead
 - Bending relief
 - Pressure vessel surface area
 - Standard LD containers for cargo
 - Landing gear rigging

- Design Variables:
- Upper & lower bay count
 - Bay length
 - Cargo bay location

McDonnell Douglas

Interior Arrangement

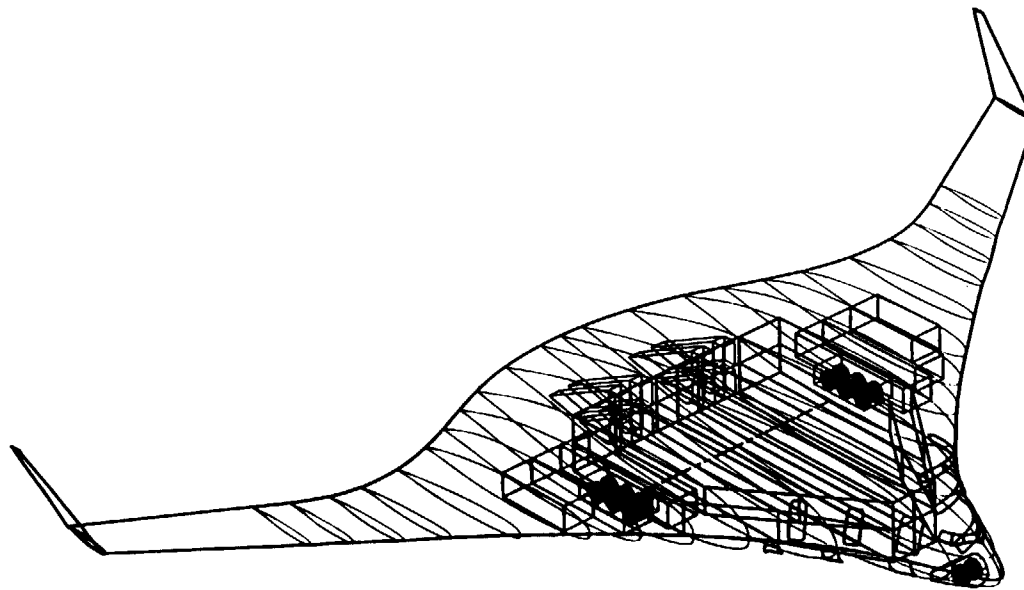

Isometric View

McDonnell Douglas

Interior Arrangement

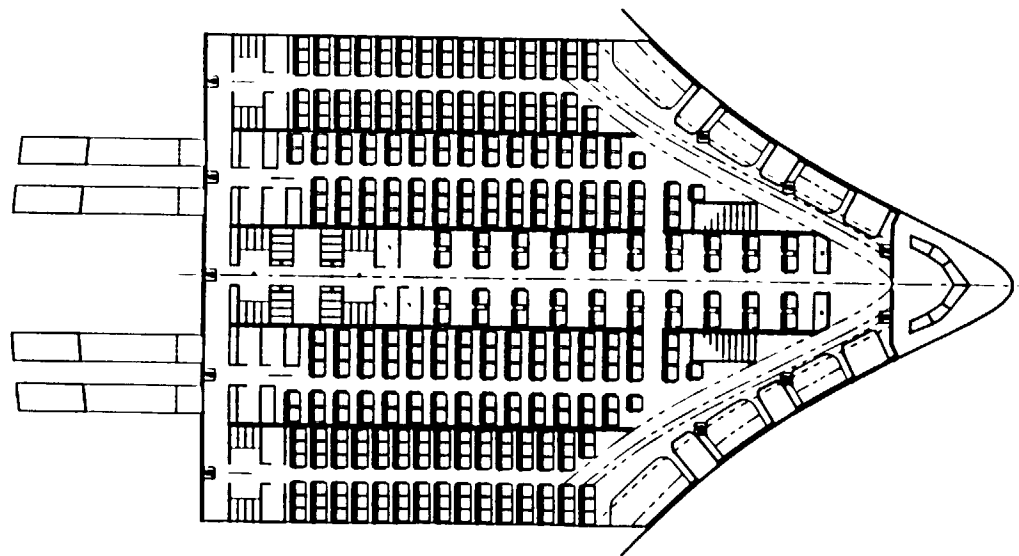

Upper Cabin Planview

McDonnell Douglas

Interior Arrangement

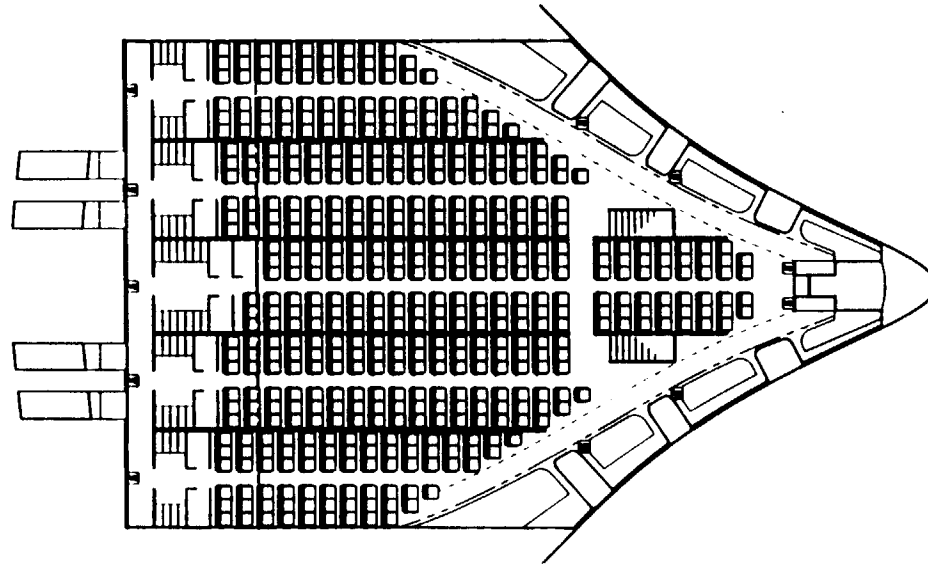

Lower Cabin Planview

McDonnell Douglas

Interior Arrangement

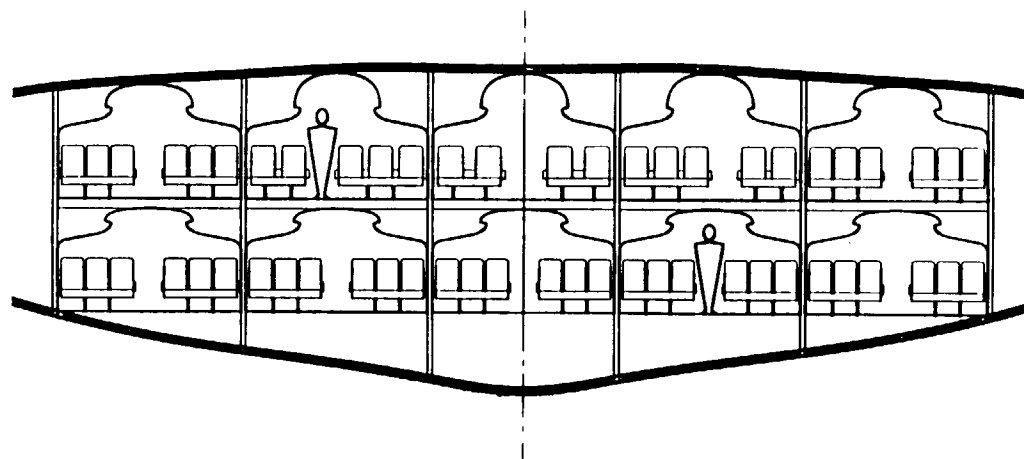

Cabin Frontal View

McDonnell Douglas

Interior Arrangement

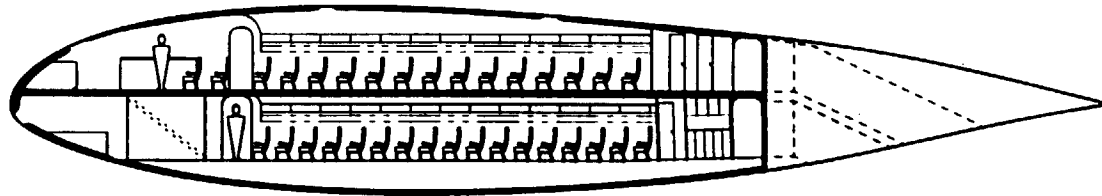

Inboard Profile View

McDonnell Douglas



KMD-11 versus Blended-Wing-Body

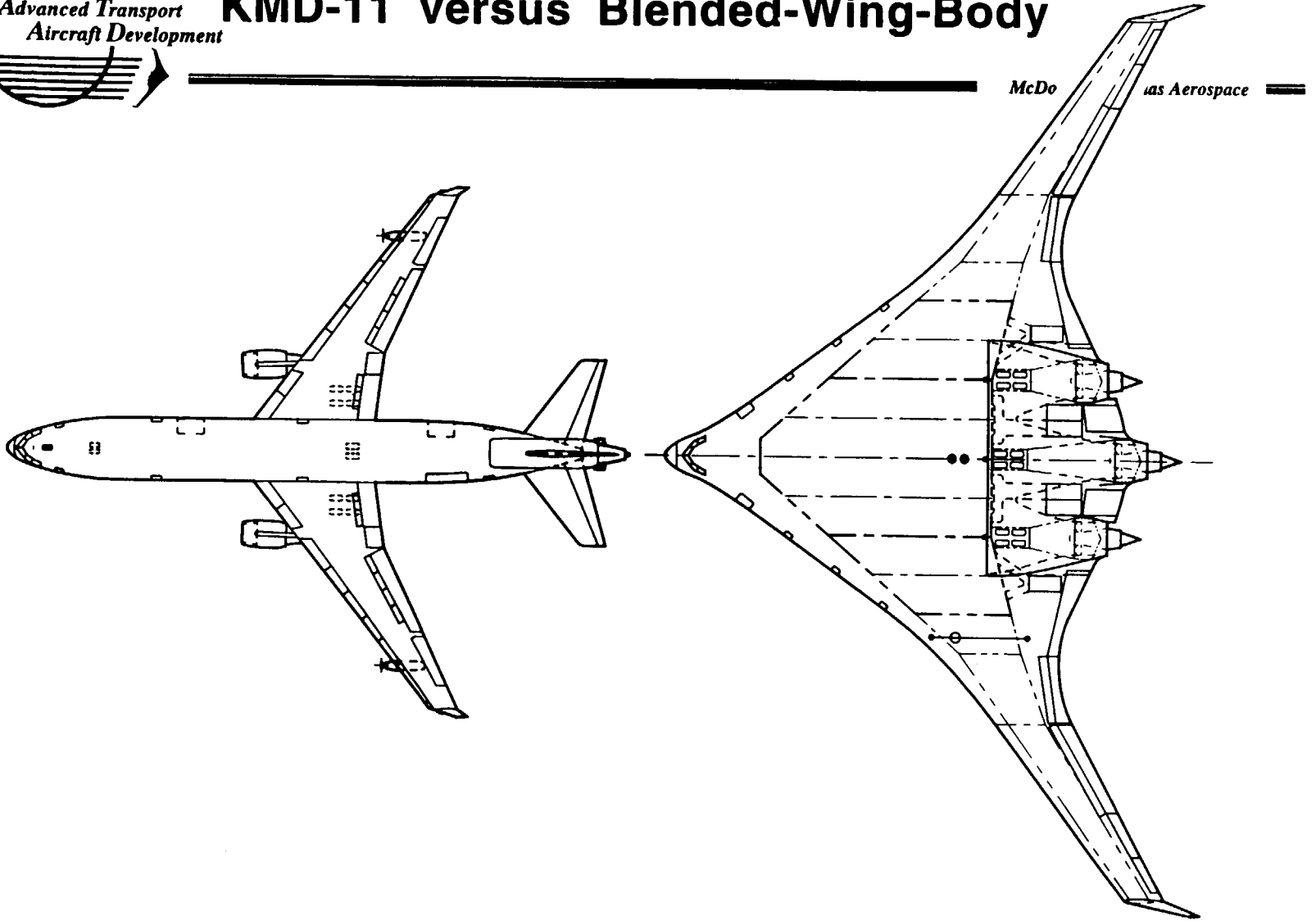

Sizing Results Comparison

Model		Blended-Wing-Body	Conventional	B-747-400
Passengers		800	800	421
Range	NM	7000	7000	7077
TOGW	LB	804,813	926,084	870,000
OEW	LB	413,819	458,319	400,100
Fuel Burned	LB	182,663	265,241	351,000
L/D @ Cruise		25.35	18.68	~19
Wing Span	FT	280	229.5	211
Wing Area (trap)	FT ²	7840	5850	5500
Total Thrust, SLS	LB	202,968	240,640	227,000
Thrust-to-Weight Ratio		0.252	0.260	0.261
TSFC	(LB/hr)/LB	0.439	0.422	~0.55

Blended-Wing-Body BWB

Range	= 7,000 nmi	800 Pax in mixed class seating
TOGW	= 804,000 lbs	Double-deck cabin
WingArea	= 7,840 sq-ft	Stitched RFI Structure
Wingspan	= 280 ft	Simple high-lift system

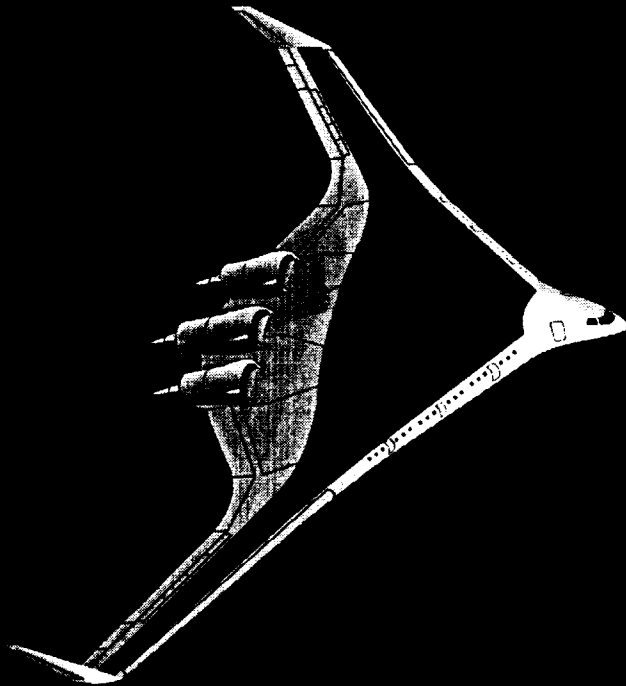

BWB performance relative to
a Conventional Configuration.

TOGW	- 13%
L/D	+ 35%
Fuel-Burn	- 31%
OEW	- 9%
Thrust	- 16%
Airframe Cost	- 10%

McDonnell Douglas