

MACROSCOPIC VIOLATION OF THREE CAUCHY-SCHWARZ INEQUALITIES USING CORRELATED LIGHT BEAMS FROM AN INFRA-RED EMITTING SEMICONDUCTOR DIODE ARRAY

P. J. Edwards and X. Huang

Advanced Telecommunications Engineering Centre, Faculty of Information Sciences and Engineering, University of Canberra, PO Box 1, Belconnen, ACT 2616, Australia

Y. Q. Li

Department of Physics, University of Arkansas, Fayetteville, AR 72701, USA

Y.Z. Wang

Joint Laboratory for Quantum Optics, Shanghai Institute of Optics and Fine Mechanics, Academia Sinica, PO Box 800-211, Shanghai 201800, PRC

Abstract

We briefly review quantum mechanical and semi-classical descriptions of experiments which demonstrate the macroscopic violation of the three Cauchy-Schwarz inequalities:

$$g_{11}^{(2)}(0) \geq 1; g_{11}^{(2)}(0) \geq g_{11}^{(2)}(t), (t \rightarrow \infty); |g_{12}^{(2)}(0)|^2 \leq g_{11}^{(2)}(0) g_{22}^{(2)}(0).$$

Our measurements demonstrate the violation, at macroscopic intensities, of each of these inequalities. We show that their violation, although weak, can be demonstrated through photodetector current covariance measurements on correlated sub-Poissonian Poissonian, and super Poissonian light beams. Such beams are readily generated by a tandem array of infrared-emitting semiconductor junction diodes. Our measurements utilise an electrically coupled array of one or more infrared-emitting diodes, optically coupled to a detector array. The emitting array is operated in such a way as to generate highly correlated beams of variable photon Fano Factor. Because the measurements are made on time scales long compared with the first order coherence time and with detector areas large compared with the corresponding coherence areas, first order interference effects are negligible.

The first and second inequalities are violated, as expected, when a sub-Poissonian light beam is split and the intensity fluctuations of the two split beams are measured by two photodetectors and subsequently cross-correlated.

The third inequality is violated by bunched (as well as antibunched) beams of equal intensity provided the measured cross correlation coefficient exceeds $(F - 1)/F$, where F is the measured Fano Factor of each beam. We also investigate the violation for the case of unequal beams.

1 Theory of The Macroscopic Violation

The first inequality addresses the correlation between the intensity fluctuations in the two beams emerging from a 50/50 optical beam splitter. Loudon^[1] gives the standard quantum result for a

single mode beam with mean photon number, $\langle n \rangle$:

$$g_{11}^{(2)}(0) = \langle n(n-1) \rangle / \langle n \rangle^2 \quad (1)$$

and Paul^[2] obtains the same result by treating the photon beam as a beam of classical distinguishable particles, subject to Bernoulli partition. In the absence of interference noise, that is for a broadband, multimode, incoherent source on time scales long compared with the coherence time and with detector areas large compared with the coherence area (Teich^[3]), this treatment is justified (as it is also for a single mode situation). It is evident from expansion of equation (1) that g_{11} may be written:

$$g_{11}^{(2)}(0) = 1 + \frac{(F-1)}{\langle n \rangle} \quad (2)$$

This form shows that any violation, (a value less than unity) requires sub-Poissonian variance ($F < 1$) and must be weak in the macroscopic limit ($n \gg 1$). Nevertheless macroscopic violation can be readily demonstrated in a Hanbury Brown type experiment using a single light emitting diode driven from a high impedance source (Edwards^[4]). The same configuration serves to show violation of the second inequality. Both these violations can be deduced from the measured covariance between the macroscopic photocurrents i_1, i_2 for the split beams.

As pointed out by Loudon^[1], violation of this inequality is a fundamental quantum result resulting from the photoelectric detection of either the transmitted or the reflected photon. As we shall see however, Loudon's assertion that "non-classical effects tend to be most marked for beams with small well defined numbers of photons" is (rather surprisingly) apparently not true for the third inequality:

$$|g_{12}^{(2)}(0)|^2 \leq g_{11}^{(2)}(0)g_{22}^{(2)}(0) \quad (3)$$

which is violated at macroscopic intensities for bunched and unbunched beams as well as for the antibunched beams for which the first inequality is weakly violated at macroscopic intensities.

It is well known that the Cauchy-Schwarz inequality with time delay t between the two beams is [2],[5],[6]

$$|g_{12}^{(2)}(t)|^2 \leq g_{11}^{(2)}(0)g_{22}^{(2)}(0), \quad (4)$$

where $g_{ij}^{(2)}$ is the second-order coherence function. For $t = 0$, we have the following inequality if we use a "classical particle" description^[2]:

$$\frac{\langle n_1 n_2 \rangle^2}{(\langle n_1 \rangle \langle n_2 \rangle)^2} \leq \frac{\langle n_1(n_1-1) \rangle}{\langle n_1 \rangle^2} \frac{\langle n_2(n_2-1) \rangle}{\langle n_2 \rangle^2}. \quad (5)$$

That is

$$\langle n_1 n_2 \rangle^2 \leq (\langle n_1^2 \rangle - \langle n_1 \rangle^2)(\langle n_2^2 \rangle - \langle n_2 \rangle^2). \quad (6)$$

In order to violate the Cauchy-Schwarz inequality, we should have

$$\langle n_1 n_2 \rangle^2 > (\langle n_1^2 \rangle - \langle n_1 \rangle^2)(\langle n_2^2 \rangle - \langle n_2 \rangle^2). \quad (7)$$

So that we have

$$F_1 F_2 (r^2 - 1) + \langle n \rangle [2r\sqrt{F_1 F_2} + 2 - (F_1 + F_2)] + (F_1 + F_2) - 1 > 0 \quad (8)$$

where r is the cross correlation coefficient and F_1 and F_2 are the Fano Factors for each beam. For macroscopic violation (large $\langle n \rangle$):

$$[2r\sqrt{F_1 F_2} + 2 - (F_1 + F_2)] > 0 \quad (9)$$

If $F_1 = F_2 = F_0$, the measured Fano Factor, we may obtain the following result from inequality (8):

$$(rF_0 - F_0 + 1) > 0, \quad (10)$$

hence

$$r > \frac{F_0 - 1}{F_0}. \quad (11)$$

We therefore have the following violation conditions:

1. For $F_0 = 1$ (Poisson), all positive correlations, i.e. $r > 0$;
2. For $F_0 < 1$ (Anti-bunched), all positive correlations, i.e. $r > 0$;
3. For $F_0 > 1$ (Bunched), $r > |(F_0 - 1)/F_0|$.

This case is shown in Figure 1.

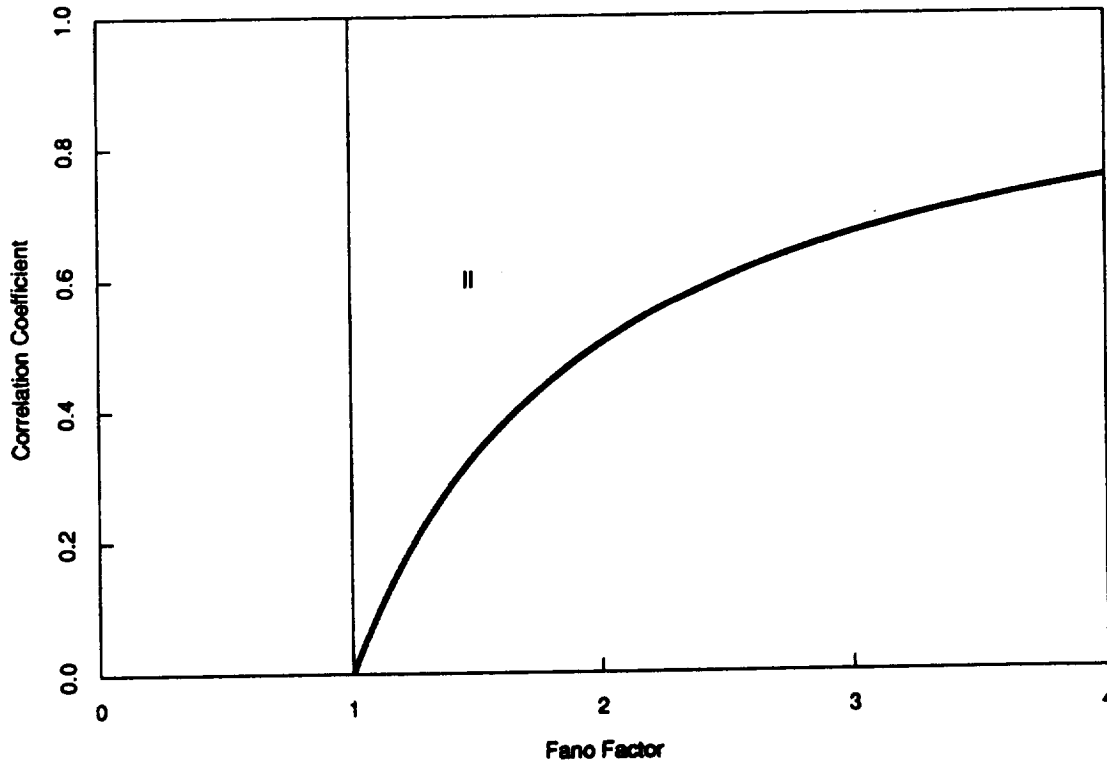

Figure 1: Two different violation regions, I ($F_0 < 1$) and II ($F_0 > 1$).

2 Violation For Twin Beams Generated by Coupled LED's

Figure 2 shows the arrangement adapted by Edwards^[4,7] to generate quantum correlated twin beams.

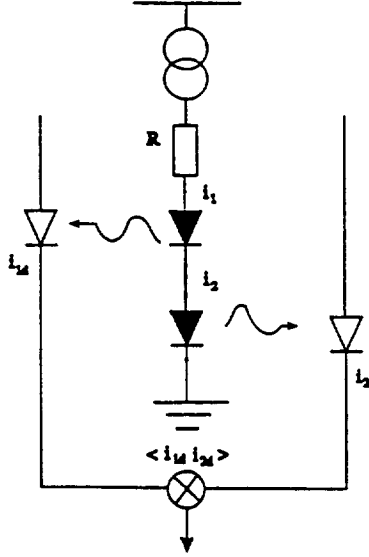

Figure 2: Series-connected infrared emitting diodes (L2656) configured to generate positively correlated intensity fluctuations.

From Figure 2, we have $i_1 = i_2$ and $\eta_1 = \eta_2$, so $i_{1d} = i_{2d}$ and $\langle i_{1d}^2 \rangle = \langle i_{2d}^2 \rangle$. The correlation coefficient is given by

$$r_{12} \equiv \frac{\langle i_{1d} i_{2d} \rangle}{\sqrt{\langle i_{1d}^2 \rangle \langle i_{2d}^2 \rangle}}, \quad (12)$$

This can be easily shown to be

$$r_{12} = \frac{\eta F_i}{F_o}. \quad (13)$$

Here F_i is the Fano Factor at the source and

$$F_o = 1 + \eta(F_i - 1) \quad (14)$$

is the Fano Factor measured at the detectors with quantum efficiency, η . Recall that the macroscopic violation for $F_1 = F_2 = F_o$ was given by

$$r_{12} > \frac{F_o - 1}{F_o}, \quad (15)$$

that is

$$\eta \frac{F_i}{F_o} > \frac{F_o - 1}{F_o} = \frac{\eta(F_i - 1)}{F_o} \quad (16)$$

A violation parameter, Δ can therefore be written as

$$\begin{aligned}
 \Delta &= r_{12} - \frac{F_o - 1}{F_o} \\
 &= \frac{\eta}{F_o} \quad (F_o > \frac{1}{2}) \\
 &= 1 + r_{12} \quad (0 < F_o < \frac{1}{2})
 \end{aligned}
 \tag{17}$$

3 Experimental Results

Referring to Figure 3, these measurements were performed at room temperature using two series connected Hamamatsu type L2656 infrared emitting diodes. The Fano factors were measured as shown with a swept frequency spectrum analyser. Correlations were measured digitally.

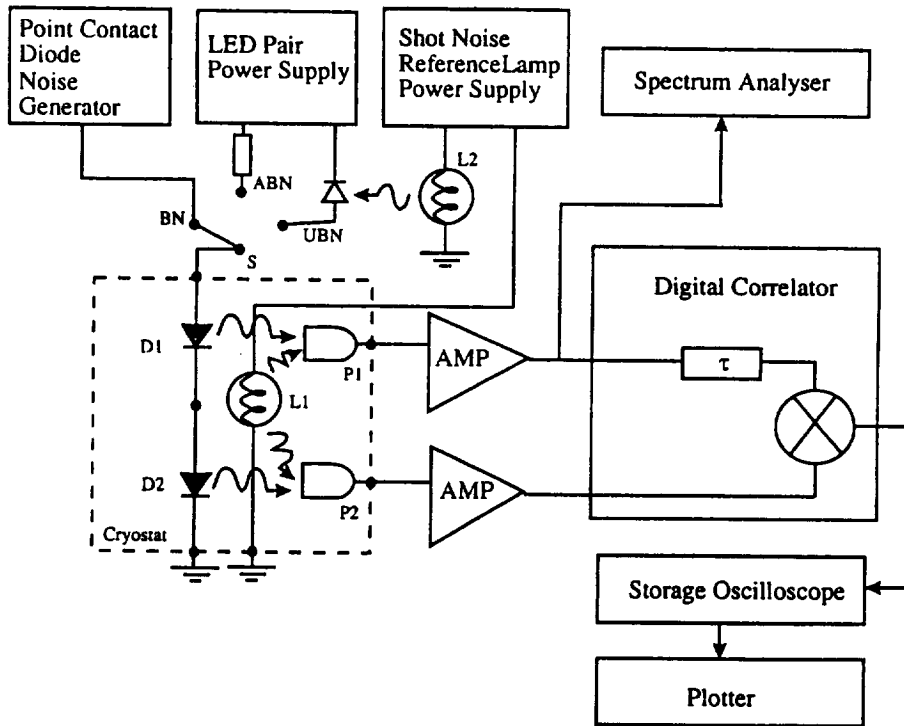

Figure 3: The correlated twin beams are generated by light emitting diodes, D1,D2. Tungsten lamps, L1, L2, provide shot noise reference currents in the pin diode detectors P1,P2, and light emitting diodes, respectively. Switch, S provides unbunched (UBN), bunched (BN) and anti-bunched (ABN) twin beams with detected Fano factors measured by the spectrum analyser. The quantum efficiencies are determined directly from the measured DC currents.

Typical results are shown in Figure 4, together with a curve showing the expected values of the violation parameter for a quantum efficiency of 10%, as employed for all measurements with the exception of the left hand point (12%). These results are in good agreement with the theory.

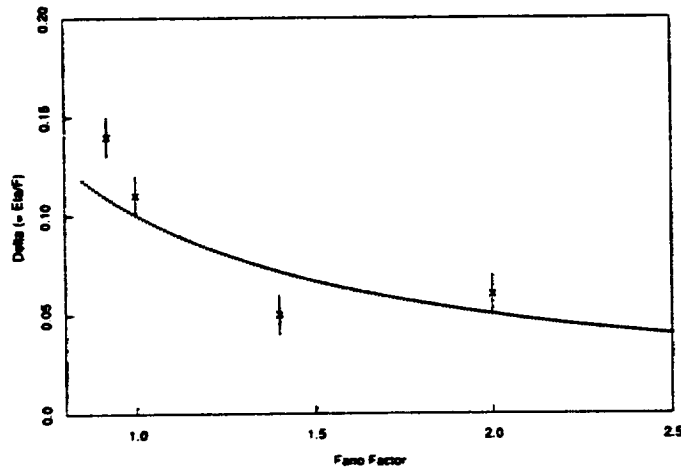

Figure 4: Experimental violation of the Cauchy-Schwarz Inequalities.

4 Conclusions

We have extended theories concerning violation of the Cauchy-Schwarz inequalities (CSI). We have derived a simple condition for the macroscopic violation of a CSI for twin incoherent light beams using a “classical particle” model. We have shown that this CSI is violated for positively correlated, bunched, incoherent twin beams.

References

- [1] R. Loudon, *Rep. Prog. Phys.* **43**, 58 (1980).
- [2] H. Paul, *Reviews of Modern Physics*, **54**, 1061 (1982).
- [3] M. C. Teich and B. E. A. Saleh, *Progress In Optics*, **XXVIII**, Edited by E. Wolf, North-Holland (1988).
- [4] P. J. Edwards, *Australian Conference on Optics, Lasers and Spectroscopy, (ACOLS'91)*, Australian National University, 150 (1991).
- [5] M. D. Reid and D. F. Walls, *Phys. Rev. A.*, **34**, 1260 (1986).
- [6] Y. Q. Li, J. P. Yin and Y. Z. Wang, in *IQEC'92 Technical Digest, Proceedings of the Eighteenth International Conference on Quantum Electronics, Vienna, Austria, MoG7* (1992).
- [7] P.J. Edwards and G.H. Pollard, *Phys. Rev. Lett.* **69**, 2867 (1992).