

EVA Assembly and Release of Highly Loaded Bolts

Jim Olmstead* and Paul Barker*

522-37
50450 ✓
125136 ✓

Abstract

The modification of a multi-jackbolt mechanism, Superbolt™¹, for on-orbit release of highly loaded bolts is described. Preload and release test data demonstrate that modification of a commercial product produced a solution for the deployment of the Space Station Remote Manipulator System (SSRMS) that was less expensive, faster, and lighter than other alternatives. Using the Superbolt design, virtually unlimited bolt loads can be applied or released with a standard wrench.

Introduction

Using highly loaded bolts for the assembly or deployment of structures in space has been limited due to torque, force, weight, shock loads, power, and/or space restrictions. Heavy torque- and force-multiplying mechanisms can be used, but they must be stored when not in use. Alternative methods of preload release include explosives, shape memory metals, and spools. Each of these methods carries a cost in terms of functional redundancy, safety considerations, and fragment/debris containment, especially for large, highly loaded bolts. When Extra Vehicular Activity (EVA) is available, a space-qualified, multi-jack bolt mechanism, Superbolt™, is simpler.

Requirements for the SSRMS Tie-Down Release System

During launch, the double-folded, SPAR-designed SSRMS is secured to a modified British Aerospace Space Lab Pallet by eight 19-mm (3/4 in) rods that are 1.15 m (45 in) in length (Figure 1). These rods are stretched over 3.8 mm (0.150 in) by an 80-kN (18000-lbf) preload. They may contain up to 100 kN (22500 lbf) during launch. During SSRMS on-orbit deployment, the rods must be unloaded and stored by an astronaut, preferably using standard EVA wrenches with less than 34 N-m (25 ft-lbf) of torque. Other desirable features are that the release mechanism requires little EVA time, is compact, easy to store, light, simple, and requires minimum development.

What is a Superbolt™?

A Superbolt™ is a patented multi-jackbolt nut that generates high loads using low torques and standard hand tools. About the same size as a conventional nut, Superbolts™ are popular for civil and industrial applications. SPAR's SSRMS application of Superbolt™ technology, illustrated in Figure 2, will be an aerospace first.

* SPAR Aerospace Limited, Space Systems Division, Brampton, Ontario, Canada

¹ Superbolt is a registered trademark and patented system of Superbolt, Inc. of Carnegie, PA.

Principle of Operation of the Superbolt™

The torque required to preload a bolt is roughly proportional to its diameter. SPAR's engineering model (EM) Superbolt™ circumvents this by using three very strong 8-mm (5/16-in) jackbolts to tension a larger 19-mm (3/4-in) rod. The combination of three jackbolts, that are 2.4 times smaller in diameter than the rods, results in approximately 7.2 times lower torque requirements. A further torque reduction results from the jackbolt small end bearing area, which absorbs much less torque than a conventional bolt head.

Proof of Concept

SPAR originally developed a force-multiplier mechanism for the simultaneous release of a pair of preloaded rods. This heavy, precise mechanism had an intricate set-up procedure and required removal and storage after deployment of the SSRMS. A weight reduction analysis resulted in its immediate replacement with the small, simple, and proven Superbolt™. Two commercial grade Superbolts™ were quickly tested on a tie-down test bed, built to test the original force-multiplier mechanism. The required rod tension was achieved with a torque significantly less than the 34-N-m (25-ft-lbf) EVA torque limit.

Engineering Model (EM)

Shortly after the successful breadboard test, an EVA-compatible, space-qualified Superbolt™ was designed, in cooperation with Superbolt, Inc. Modifications made were:

General

- 1) Use of stress corrosion cracking-resistant materials.
- 2) Prevention of galling by using dissimilar materials at each interface.
- 3) Generation of drawing conforming to DOD-STD-100, including references to controlled processes, such as non-destructive testing.

Jackbolts

- 1) Use of 19-mm (7/16-in) EVA jackbolt heads.
- 2) Use of 260-ksi MP35N to reduce jackbolt diameter and thus required torque.
- 3) Lubrication of jackbolts with space-qualified Lubeco 905 lubricant.

Nut

- 1) Increase of nut diameter for greater EVA jackbolt access.
- 2) Integration of a tether loop into the nut.
- 3) Increase of nut height to meet fracture requirements.

Note that in order to measure torques accurately, the EM bolts did not have any locking features. To prevent loosening during the high vibration of launch, the flight jackbolts will each have a polyester film locking pellet on the thread. The above modifications were checked for compliance with Space Station requirements by performing finite element, fracture, and thermal on-orbit touch temperature analysis.

EM Test Results

Rods and EM Superbolts™, fabricated by Superbolt, Inc., were tested in the tie-down test bed. Rod tension and bending were measured with strain gauges. Jackbolts were torqued with a torque wrench in sequence by one turn per bolt per sequence. This procedure was used to tighten and loosen the jackbolts. During test, the jackbolts were tightened and untightened several times, up to 3.5, 4.0, and 4.5 jackbolt turns. These roughly represent 90-, 100-, and 115-kN (20,000-, 22500-, and 25500-lbf) rod loads, respectively. Generally, the thread coefficient of friction decreased with both jackbolt load and test number (Figure 4). As a final test, the Superbolt™ was loaded to over 130 kN (29600 lbf). The ends of the jackbolts mushroomed slightly and indented the thrust washer. The apparent coefficient of friction increased about 30% but was still very low. This increase may have been due to plastic deformation of the washer and/or lubricant failure. Although the bolt load was 50% greater than required, a harder washer and/or a thicker lubricant is suggested to increase the bolting system capacity. Test results for torque versus preload and release are shown in Figure 5. The Superbolt™ torques were about 10 times less for assembly and release than for an equivalent 19-mm (3/4-in) bolt. The number of jackbolt turns versus preload and the bending in the tie-down bolt due to loosening of one jack bolt were also obtained from test. Briefly, the results were:

Assembly torque	@ 80 kN (18000 lbf)	15.0 N-m (11. ft-lbf)
Release torque	@ 87 kN (19500 lbf)	10.2 N-m (7.5 ft-lbf)
Total energy released		170. N-m (125 ft-lbf)
Jackbolt turns to release		4.9 turns

The release torque was less than one third of the available 34-N-m (25-ft-lbf) continuous EVA torque and less than a quarter of the maximum available 54-N-m (40-ft-lbf) momentary EVA torque. To prevent excessive bending in the preloaded rods, only two turns per jackbolt per sequence during untorquing were allowed. Neutral buoyancy simulation tests, performed at Marshall Space Flight Center, confirmed the Superbolt™ accessibility for release and the feasibility of storing the bolts prior to their return to Earth. Timelines have been developed for the Superbolt™ release tasks and are within the EVA time allowances for the mission. In fact, actual Superbolt™ EVA time is comparable to the previous force-multiplying mechanism because the Superbolt™ can be undone with standard EVA tools, and its compact size does not require separate storage from the rods.

Flight Hardware

The flight hardware was built by SPAR under license from Superbolt, Inc. SPAR's experience with space-related requirements and quality assurance made this the most effective solution.

Summary

Design, analysis and verification of the SSRMS Superbolt™ has been performed. The Superbolt™ allows release of 110-kN (25000-lbf) bolt loads while using less than a third of the available on-orbit torque. The application of the Superbolt™ concept for the assembly and release of highly loaded bolts in space demonstrates that adaptations of proven commercial products are viable alternatives to unique, complex designs.

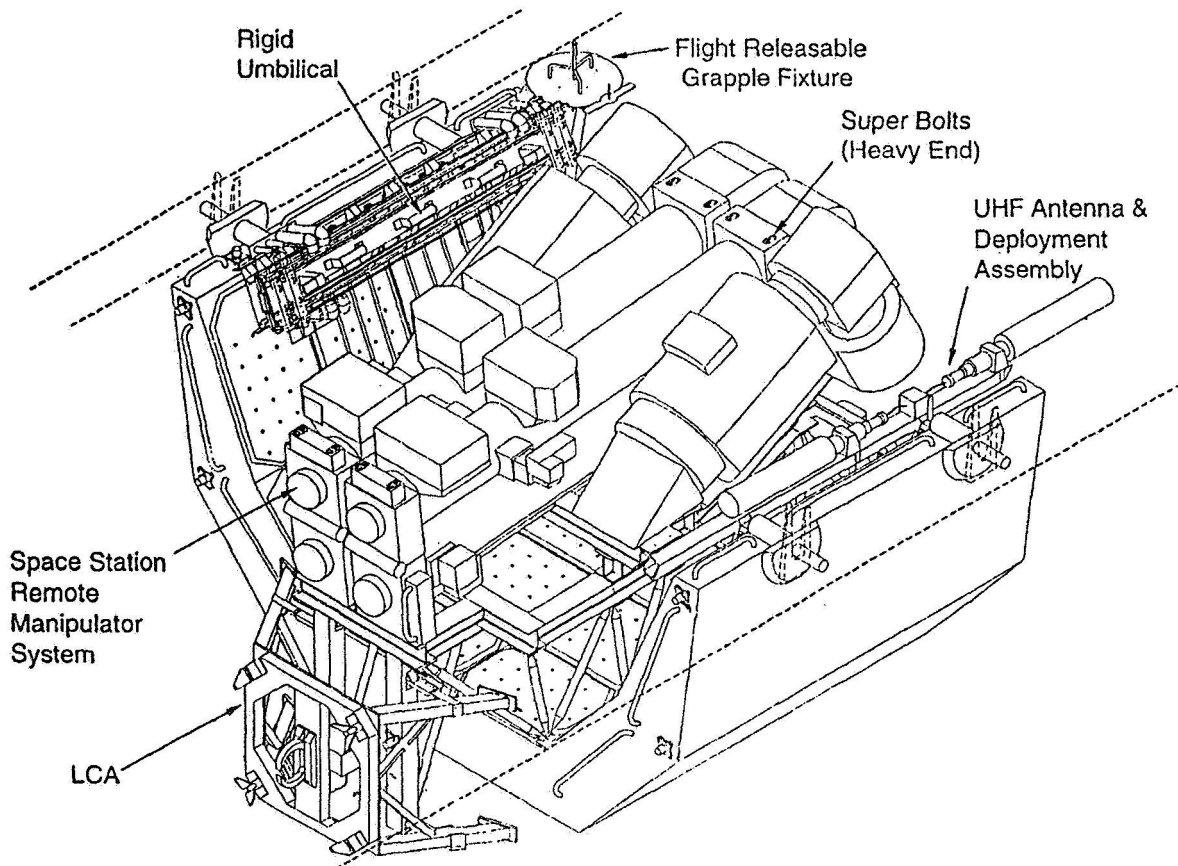

Figure 1. SSRMS Launch Configuration

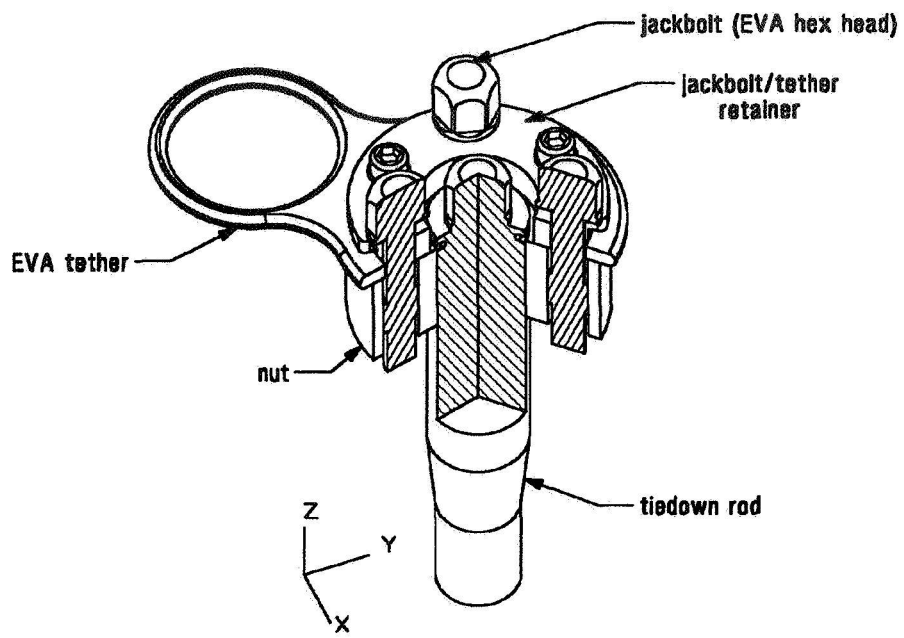

Figure 2. Superbolt Detail

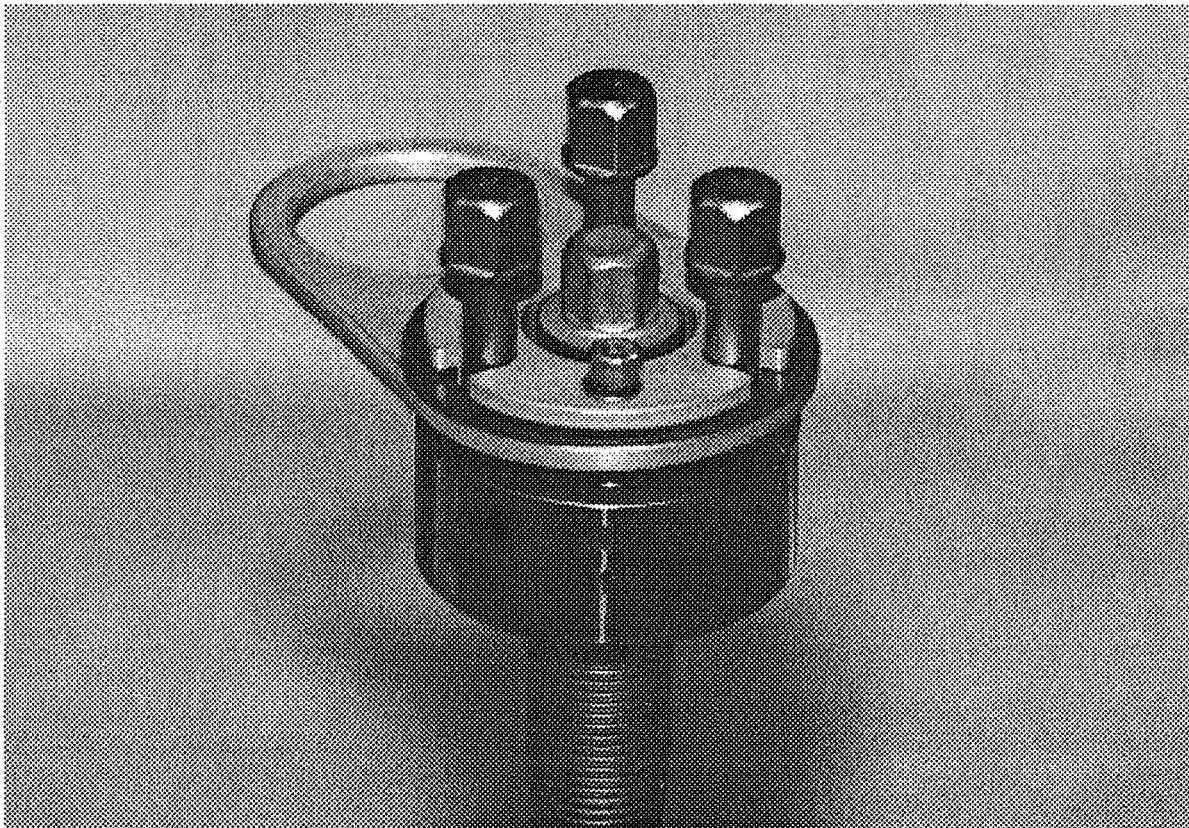

Figure 3. Flight Superbolt

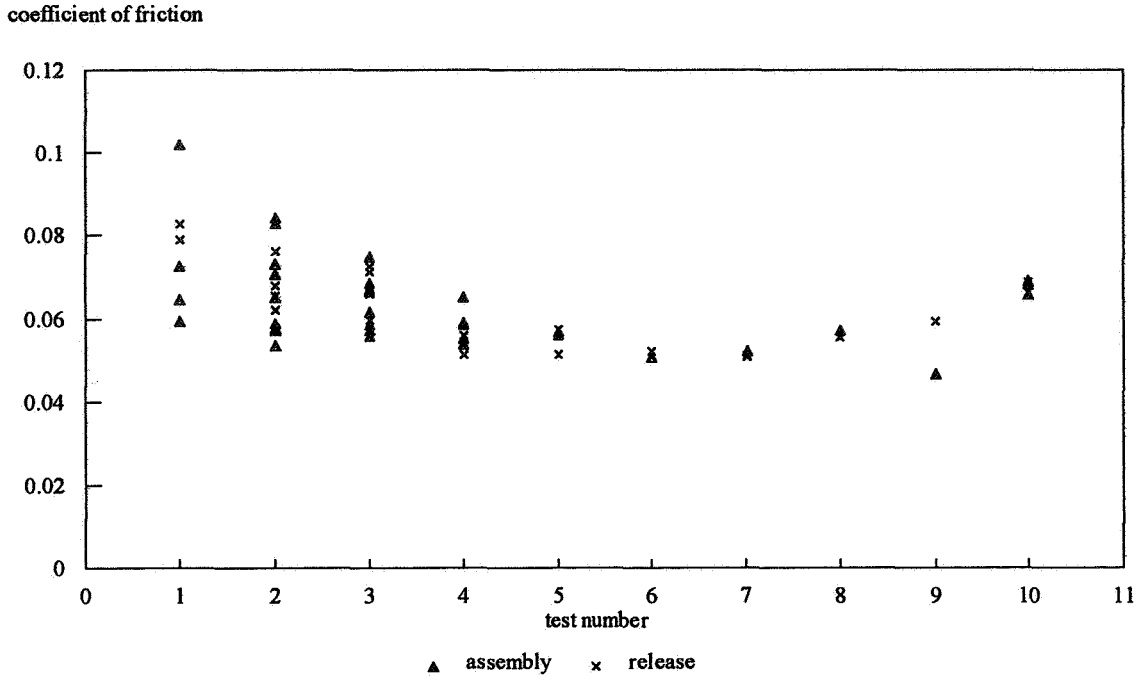

Figure 4. Friction vs Test Number

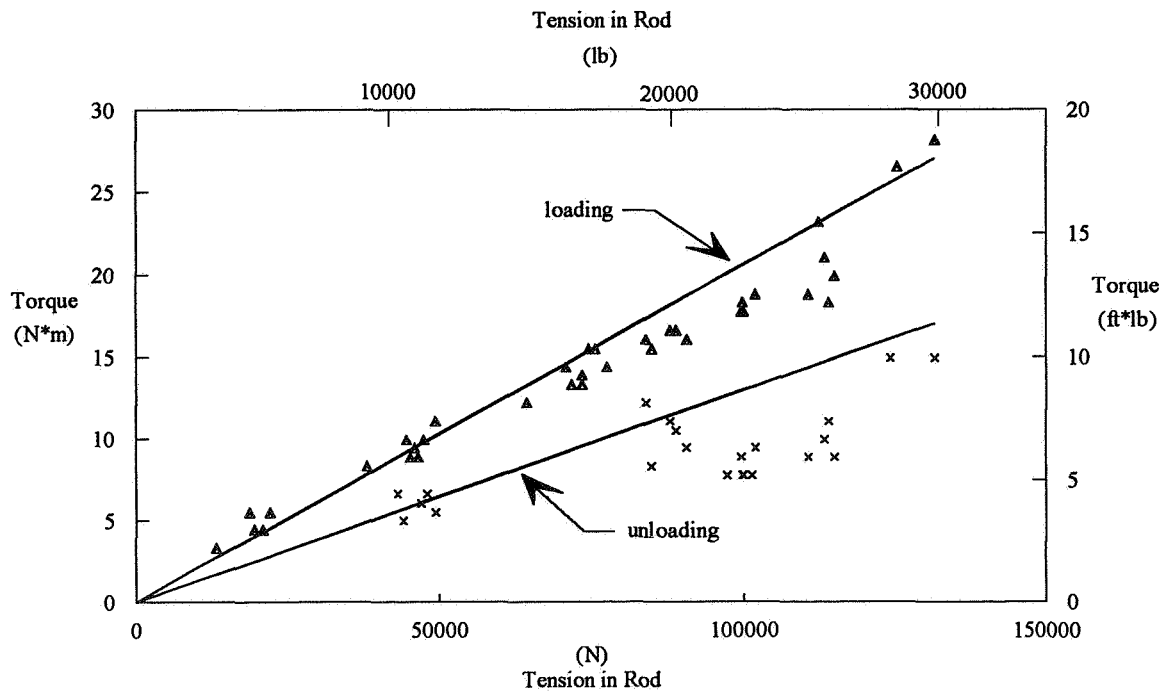

Figure 5. Torque vs Preload