

Progress Toward Demonstrating A High Performance Optical Tape Recording Technology

0-220

W. S. Oakley
LOTS Technology, Inc.
1274 Geneva Drive
Sunnyvale CA 94089
408-747 -1111
Fax: 408-747 - 0245

In September 1995 LOTS Technology received an award under the Advanced Technology Program to pursue high performance digital optical tape recording technology using a green laser source. The program is a two year technology development effort with the goal of demonstrating useful read/write data transfer rates to at least 100 megabytes per second and a user data capacity of up to one terabyte per cartridge implemented in a system using a '3480' style mono-reel tape cartridge. Although both write once and erasable phase change optical media have been previously demonstrated, and both are compatible with this technology, current availability limits this effort to the use of write once media. This paper discusses the technology developments achieved during the first year of the program during the period September 1995 through August 1996.

LOTS
TECHNOLOGY



Figure 1a: Basic System Approach

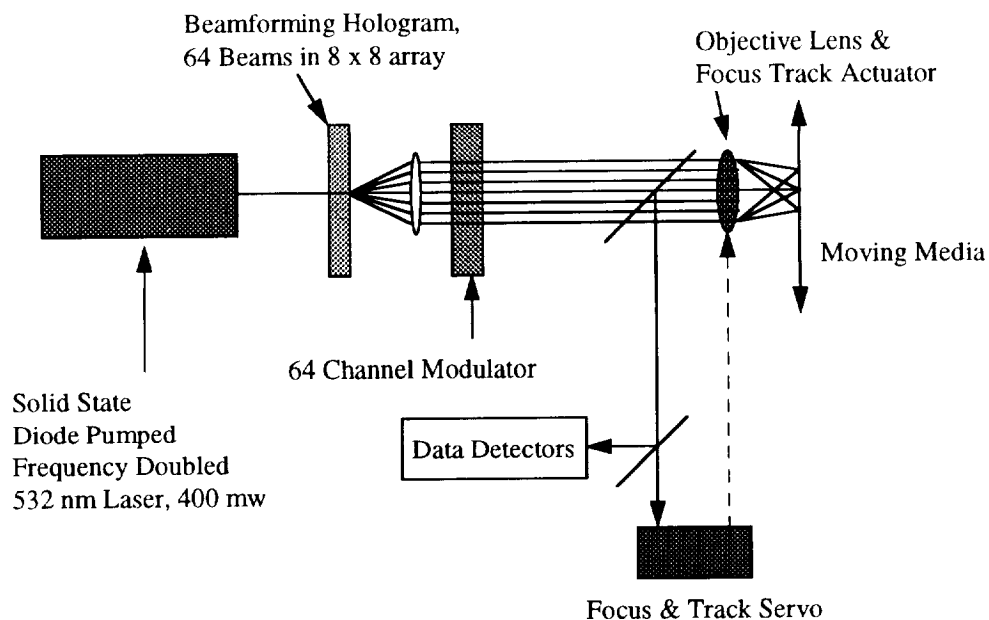

The primary intent of the program is to develop the technology for multi-beam digital optical recording and playback at high data transfer rates, 100 MB/sec. and above, and consistent with a minimum of a terabyte capacity per data cartridge. The basic design is implemented by a linear tape transport moving tape at several meters per second while the tape media is written to longitudinally by means of an array of focused and modulated laser beams. All writing beams are derived from a single diffraction limited green laser operating at 532 nanometers. The design is implemented using a hologram as a passive Beam-forming element to split the output from a single laser source into an array of 64 similar optical beams, each of which is independently modulated prior to focusing on the media with a nominally half micron spot size. Beam modulation is implemented at rates to 20 MHz. by means of an array modulator of 64 elements, one element for each beam. The basic recorder design concept is shown in **Figure 1a** and the optical implementation in **Figure 1b**.

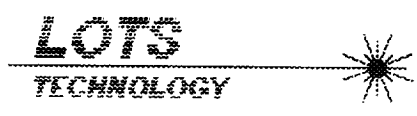
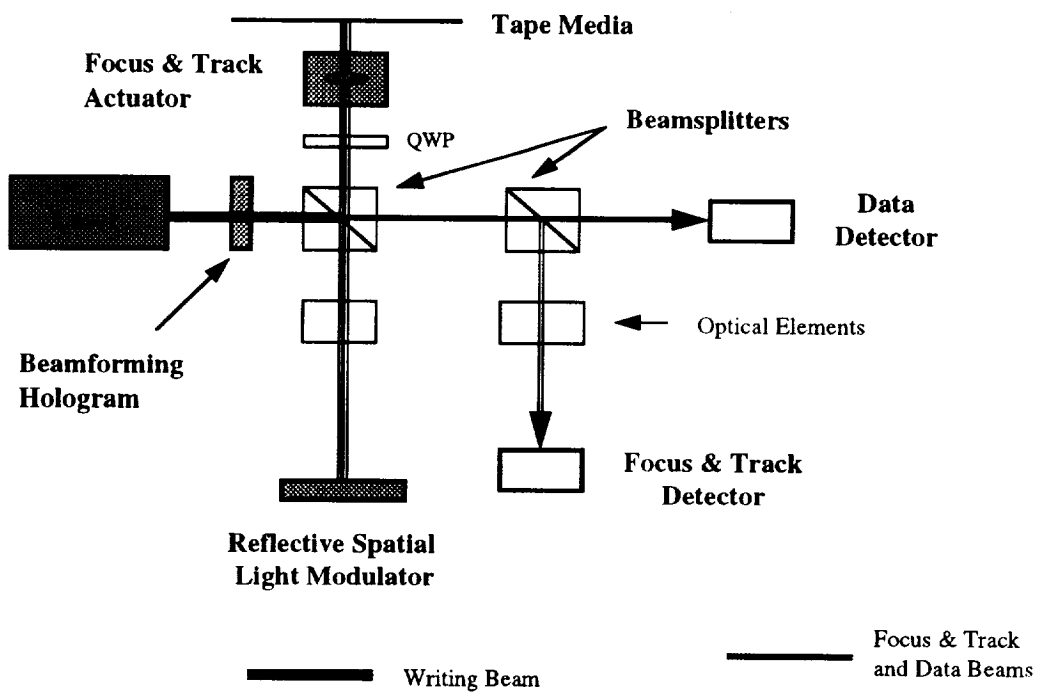

Figure 1b: Optical Implementation



96Naa1b.ppt

A conceptual physical layout of a future product is shown in **Figure 2**, emphasizing the inherent benefit of no head/media contact for optical recording and the preference for a clean tape transport environment to minimize media contamination by dust and dirt. The mechanical media transport system is configured to eliminate contact between the media

recording surface and any transport component. The only recording layer contact is with the rear surface of the tape when it is wound either onto the take-up reel or into the cartridge.

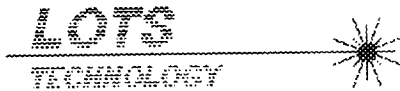
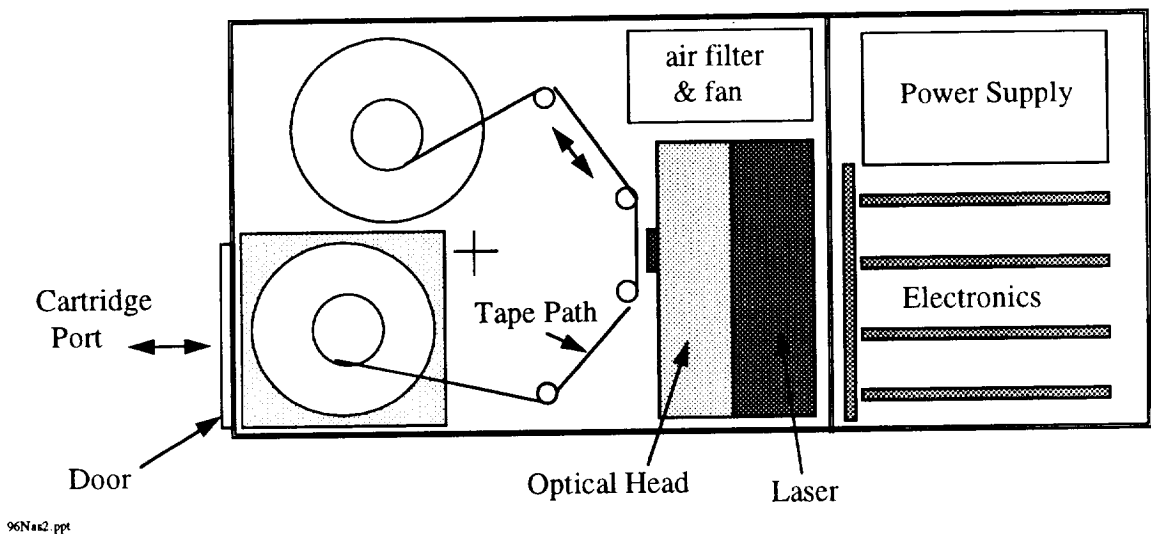

Figure 2: Conceptual Physical Layout

- * No Contact with Media Recording Surface
- * Media in Filtered Air Environment



The overall system performance is directly determined by the specific implementations and the individual performance characteristics of the key components of the intended design. The design approach required to demonstrate a 100 MB/sec. transfer rate consists of the following major components;

- (1) The tape transport.
A linear tape transport is desired to move half inch wide optical tape in a controlled manner at speeds up to about ten meters per second. The baseline design requires a tape speed of eight m/sec. for a 100 MB/Sec. user data rate.
- (2) The array beamformer.
An array beamformer is required to produce an array of 64 similar optical read/write beams from a single diffraction limited input beam at a wavelength of 532 nm.
- (3) The array modulator.
An array modulator is required to modulate each beam in the write array at a rate consistent with the desired bit writing rate, i.e. modulator rise and fall times of under 10 nanoseconds for the 100 MB/sec. system.

(4) Write/read channel data encoding and system.

Each write/read beam in the array and its associated detector forms a data channel for writing/reading to/from the media. Increased system performance is achieved by encoding the data to improve the linear bit density in a track, thereby increasing system capacity and minimizing both tape speed and laser power requirements.

(5) The 532 nm laser.

A green laser operating at 532 nm is required with sufficient power to write to the media at the desired data rates, allowing for system optical transmission efficiency. The laser must be diffraction limited with a low noise amplitude to preserve data integrity. At the 100 MB/sec. data rate a source laser power of about 400 mW is required for the optical media currently in use.

(6) A multi-element detector.

A detector array matched to the format of the optical footprint on the tape media is required for data retrieval.

(7) Focus and track capability

A means must be provided of both maintaining optical focus on the moving media and following a previously written track group to sub micron accuracy for data retrieval.

The key characteristics of these components are interrelated with the basic system performance being developed as follows. The degree of data encoding employed directly affects the linear bit recording density and in conjunction with a given track spacing and tape width thereby determines the tape length for a given capacity. The bit density also directly affects the tape speed required to achieve a given data rate for a specified number of simultaneously written (or read) bit tracks. For a track spacing of 0.88 microns and a track group consisting of 64 individual bit tracks, each track group occupies a section of tape 56.32 microns wide. With a guard band of two bits between track groups a group occupies 66 track widths or 58.08 microns. Therefore, 200 track groups can be written across a half inch (12.7 mm) wide tape and occupy 11.62 mm., leaving unwritten bands of 0.54 mm on each of the upper and lower tape edges. For a system of 1 Terabyte user capacity per cartridge with a data overhead of 30% of the raw capacity, a total capacity of $1,000/0.7$ or 1,428 gigabytes is required. For 200×64 (= 12,800) data bit tracks this corresponds to a requirement of 111.56 megabytes or 892.5 megabits per bit track. This is 5.0 user (7.14 raw) gigabytes per 64 bit track group per tape length. For a system recording data with a linear density of 1 bit per micron, each bit track would therefore be 1.00×111.6 meters = 892.5 meters in length. It follows that a linear density of 2 bits per micron requires a tape length of 446.25 meters, and a tape length of 400 meters requires a bit track density of 2.23 bits/micron, etc..

The maximum length of tape that can be wound onto the 50 mm diameter hub in the industry standard 3480 cartridge is a function of the tape thickness and the maximum allowed outer tape pack diameter. A maximum outer diameter of 100 mm is assumed for the 3480 cartridge tape pack, (the reel flange diameter is 101 mm), which for 13 micron

thick optical tape gives a maximum tape length of 453 meters which results in a minimum linear recording density requirement of 1.97 bits per micron for a one terabyte capacity. A more conservative tape length of 400 m requires a linear bit density of 2.23 bits/micron. To provide a one terabyte capacity in the '3480' style cartridge the data linear density per track must therefore be at least 1.97 and preferably greater than 2.23 bits per micron if a maximum of 400 meters of tape is used. The tape pack diameter for various lengths of 13 micron thick tape are given in **Table 1**.

Table 1. Outer Tape Pack Diameter vs. Tape length for 13 Micron Thick Tape..

Tape Pack Diameter in mm.	85	90	95	100
# Tape Wraps in Pack	1,346	1,538	1,730	1,923
Avg. Length/wrap - mm	212	219.9	227.8	235.6
Total Length - m	285.4	338.2	394.1	453.0

Note: The maximum flange diameter for a '3480' cartridge reel is 101 mm.

With a bit density of 1.97 bits/micron the tape velocity corresponding to a 100 MB/s. transfer rate in a design with 64 parallel data channels is 9.06 m/sec.. For the same channel parallelism and data rate, and with a bit density of 2.23 bits per micron the required tape speed is 8.0 m/sec.. Higher bit densities, i.e. of 3 bits/micron (or more), are preferred and would allow tape speeds below 6 m/sec. however such bit track densities are unlikely to be achieved with a 0.532 micron wavelength laser source and PPM (Pulse Position Modulation) encoding. Greater data storage densities can be achieved by the use of PWM (Pulse Width Modulation) encoding but are not necessary to achieve the program performance goals and would entail considerably greater effort and technological risk.

With the user capacity at 70% of the raw capacity a 100 megabyte/sec. user data rate requires a raw rate of $(100/0.7 =)$ 142.86 megabytes/sec., giving a raw bit rate of 1,142.9 megabits/sec. over 64 data channels, or 17.86 megabits/sec. per channel. At a linear density of 1 bit per micron this requires a system tape speed of 17.86 meters/sec.. Higher linear bit densities require less tape to provide a given capacity and consequently require lower tape speeds for any given data rate. Greater read/write channel parallelism, i.e. more bit tracks per track group, also permit a lower tape speed for a given aggregate data rate, but has no effect on cartridge capacity. Higher track densities also reduce the time to end of tape (EOT) for a given total capacity. The tape lengths and speeds required for various linear track densities (# bits per micron) for a one terabyte capacity system operating at a user data rate of 100 megabytes/sec. are given in **Table 2**.

Table 2. Tape Length per Terabyte & Tape Speed vs. Channel Parallelism, at Various Linear Bit Track Densities.

Linear Density (bits/micron)	Tape Length / TB meters	Tape Speed (meters/sec.) vs. Number Bit Tracks per Track Group @ 100 MB/sec.		
		64	96	128
1.0	892.5	17.86	11.91	8.93
1.5	595.0	11.91	7.94	5.95
2.0	446.3	8.93	5.95	4.46
2.5	357.0	7.14	4.76	3.57
3.0	297.5	5.95	3.97	2.98
3.5	255.0	5.10	3.40	2.55
4.0	223.1	4.46	2.98	2.23

With a system capacity of one terabyte configured into 200 parallel track groups each of 5 gigabytes the time to the physical end of the tape is obviously the same for a given data rate regardless of the linear bit track density. i.e. The time to read/write each track group of 5 gigabytes, at a 100 MB/s.(= 0.1 GB/s.) data rate is $(5 / 0.1) = 50$ seconds. The time to write/read the entire tape is 200 times greater at 10,000 seconds or 2.778 hours.

For a diffraction limited green laser system operating at a wavelength of 532 nm the recording spot size is determined by the F/number (or Numerical Aperture, N.A.), of the objective lens which focuses each spot onto the optical tape media. A N.A. of 0.6 corresponds to an F/number of 0.666 which for a plane wave incident on the lens would create an Airy disc of radius $1.22 \times 0.532 \times 0.666 = 0.433$ microns. For a slightly truncated Gaussian input beam as used in this system the full width at the half maximum (FWHM), power point of the focused writing beam is slightly less than this at about 0.39 microns. This is the nominal width of each written bit track on the media. The bit track separation of 0.88 microns is therefore more than twice the track width, providing greater than 20dB isolation between adjacent tracks on data readback.

The required modulator response times to write a bit of appropriate mark length on the tape can be determined as a function of tape speed using the somewhat arbitrary criteria of write pulse rise/fall times equal to 10% of a bit mark at that speed. For a system using a green laser operating at 0.532 micron wavelength a minimum sized bit mark can be considered as nominally one wavelength long; i.e. 0.5 microns. Hence, for example; a rise time of one microsecond occurring during transit of 10% of a bit mark of 0.5 microns gives a tape speed of 0.05 microns per microsecond or 0.05 m/sec. Modulator rise times of 100, 10, 1 nanoseconds similarly correspond to tape speeds of 0.5, 5.0, and 50 meters/sec. respectively. As shown above, linear recorded bit densities between 2 and 3 bits per micron require tape speeds of between about 9 to 6 m/s., and therefore correspond to modulator rise times from approximately 5.9 to 8.8 nanoseconds. Tape speeds and array modulator rise times over these ranges have been demonstrated by LOTS during the first

year of the ATP program, thereby validating these parameters in regard to the chosen design approach.

The data in Table 1 and Table 2 and the associated modulator response times are shown graphically in **Figure 3**. As the per cartridge tape length is limited to about 450 meters, recording densities below two bits per micron (0.5 microns/bit) do not provide a terabyte capacity. Pulse position encoding does not provide recording densities above about 2.3 bits/micron (0.435 microns/bit). Therefore to provide a terabyte capacity and reduce program risk by the use of standard PPM encoding, the system must operate in the range between 0.435 and 0.5 microns/bit. Selection of the standard PPM (2, 7) code provides a bit density of 2.22 bits/micron (0.45 microns/bit), requiring a tape speed of 8 m/sec for 64 parallel channels, or 4 m/sec. for 128 parallel channels, etc. to obtain the 100 MB/sec. data rate. A design utilizing fewer channels requires a proportionately greater tape speed and consequently a faster modulator response to enable recording. Two dimensional modulator arrays on about 150 micron centers have been fabricated and tested during the first year of the program.

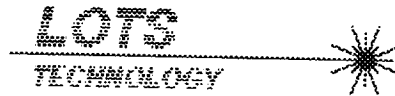

**Figure 3: Tape Velocity vs. Encoded Data Density
for 100MB/s. Data Rate**

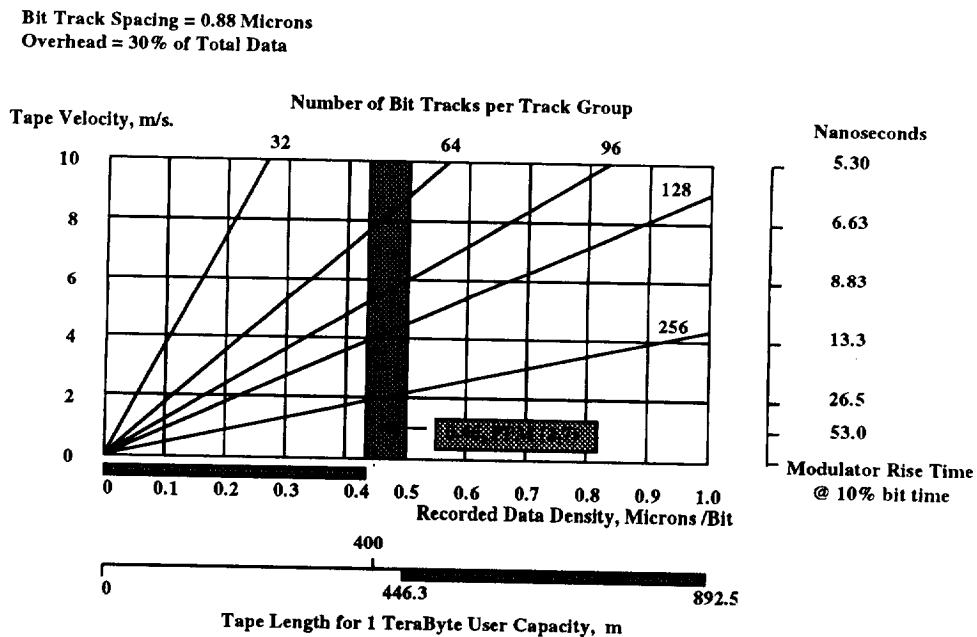

96manca - NASS.ppt

An oscilloscope trace of the response of a typical modulator element in the array to a drive pulse is shown in **Figure 4**. The specific modulator configuration tested required an 80 volt drive signal to achieve almost 100% throughput. Tests on various arrays have shown all modulating elements to perform in a nominally identical manner and the inter element crosstalk to be minimal. The writing beam quality is not significantly affected by the modulator, a diffraction limited output being maintained. The use of array modulators is therefore considered validated for the high data rate multi-beam recording application. Work is continuing to optimize the modulator geometry to reduce the drive voltage to a significantly lower level.

LOTS
TECHNOLOGY



Figure 4: Modulator Optical Response

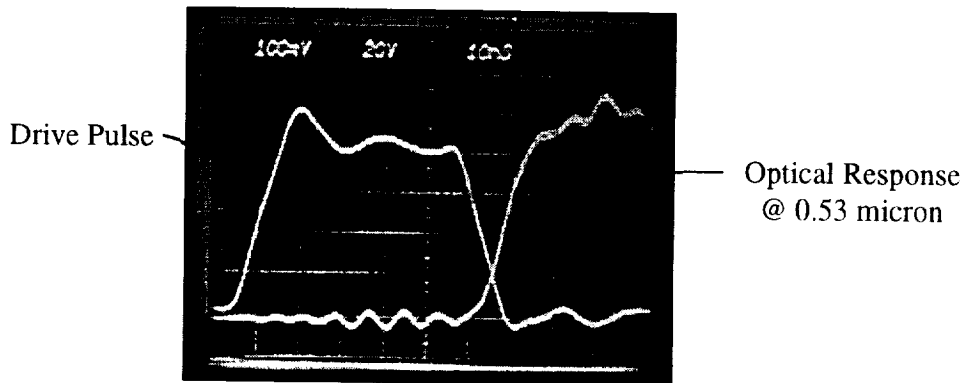

Transmissive Mode Response to 100 v Drive
Time Scale = 10 nanoseconds/div.

96NAS4ppt

The 64 data bit array to be recorded on the media is derived from a two dimensional array of 8x8 beams where other ancillary beams external to the main array are used for focus and tracking. The 8x8 beam pattern output from the Beam-forming hologram forms the closely spaced track group array of 64 tracks by virtue of being rotated a few degrees to the direction of tape motion as shown in **Figure 5**.

Figure 5: 100 - T Beamforming Pattern
64 Beams in Tilted 8 X 8 Array

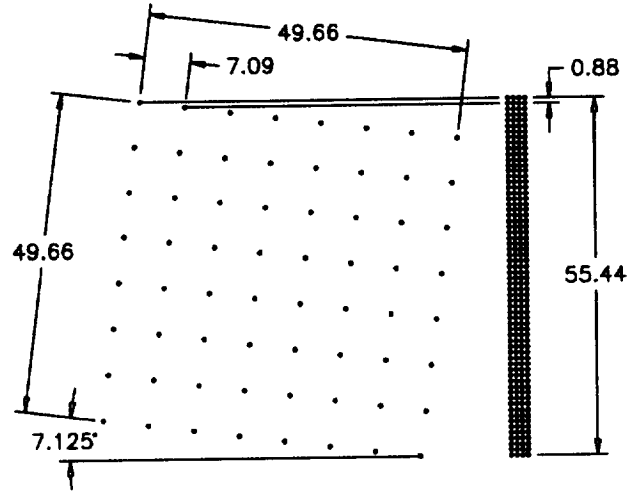

GREEN - 532 nm
8 X 8 SPOTS ON .88 CENTERLINES
DIMENSIONS IN MICRONS

For any $N \times 8$ sized array with equal spacing in both axes the rotation angle to achieve equal spacing of all tracks in the recorded track group is $\text{Tan}^{-1} 1/8$ or 7.125 degrees. Each track group is separated from those adjacent by two track spaces so the 200 track groups, each effectively 66 bits and 58 microns wide, are evenly spaced across the tape width as shown in **Figure 6**. Read/write access to any one track group is individually achieved by vertically positioning the optical head across the tape width by means of a stepper motor.

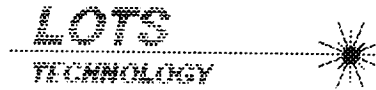
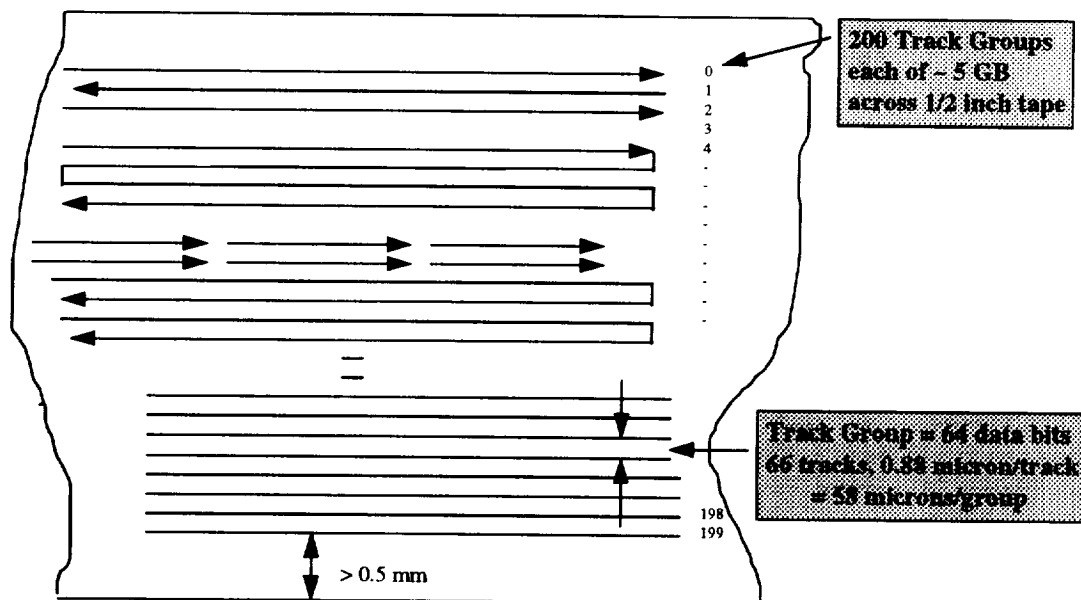

Figure 6: 100-T FORMAT

200 BOT, x 64 data bits, Serpentine, Linkable, Bi-directional



96Naa6.ppt

The key requirements for the holographic beamsplitter include generating the desired angular spread for the two dimensional beam array while obtaining a high diffraction efficiency and uniformity of output into each beam. An initial test hologram has been fabricated providing a 3×11 beam array test pattern and shows a total efficiency of 73% in the main array and a beam to beam intensity uniformity of better than 5%. Work continues on improving the holograms with the goal of achieving an efficiency of greater than 90% during the coming year.

A breadboard tape transport has been designed and fabricated and is being used for initial writing tests on phase change optical tape media supplied by Kodak. These tests indicate a power requirement to write a half micron wide line of about 0.4 milliwatts per meter per second of tape speed above four meters per second. Below four meters per second increased write power is required to compensate for thermal diffusion of the write energy.

A tape speed of eight meters per second therefore requires 3.2 milliwatts at the media for each bit track. Sixty four simultaneously written bit tracks are therefore expected to require about 205 milliwatts of power at the media. With an optical system efficiency of nominally 75% excluding the hologram and a hologram efficiency of 73%, a 400 milliwatt laser will deliver $400 \times 0.73 \times 0.75 = 219$ mW of optical power to the media, sufficient for writing 64 tracks at the required tape speed. **Figure 7** shows a single bit track 0.6 microns wide written at two meters per second with a 500 KHz modulation rate imposed via one element of the array modulator.

Figure 7: 500 KHz Written Bit Track

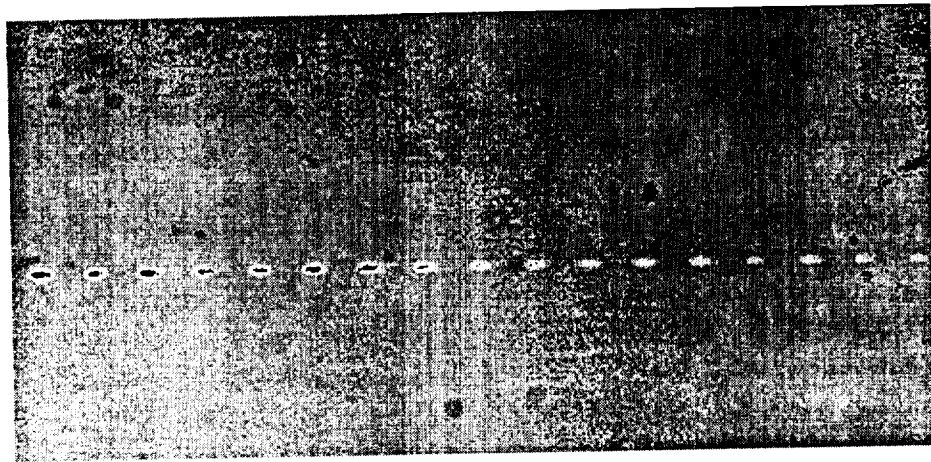

Phase Change Media, 2 meters/sec., 0.6 micron wide, 4 micron/cycle

96NAS7.ppt

Summary and Conclusions

Significant progress has been made during the last year toward validating both the recorder design approach and the individual component technologies necessary to achieve the 100 MB/sec. data rate. The demonstrated performance of the tape transport, the laser, the holographic optical element, the modulator array, the system optics and the media indicate that no serious technological impediment exists to engineering a digital optical tape recorder able to read/write digital data at rates of at least 100 MB/sec. and user data capacities of a terabyte in a single '3480' style cartridge. The next year's effort will be directed at improving the individual components and integrating them into a technology demonstration at the full data rate.

