

NASA Technical Memorandum 107307

107307
107307

Sliding Contact Bearings for Service to 700 °C

Harold E. Sliney
*Lewis Research Center
Cleveland, Ohio*

September 1996



National Aeronautics and
Space Administration

Trade names or manufacturers' names are used in this report for identification only. This usage does not constitute an official endorsement, either expressed or implied, by the National Aeronautics and Space Administration.

SLIDING CONTACT PM212 BEARINGS FOR SERVICE TO 700 °C

Harold E. Sliney, D.R.A.*
National Aeronautics and Space Administration
Lewis Research Center
Cleveland, Ohio 44135

SUMMARY

Cylindrical, sliding contact bearings made entirely of a self-lubricating powder metallurgy composite (PM212) or of super alloy shells lined with clad PM212 were tested in an oscillating mode at temperatures from 25 to 700 °C. Tests of 100 hr duration or longer were conducted at a bearing unit load of 3.45 Mpa (500 psi). Shorter duration tests at various unit loads up to 24.1 Mpa (3500 psi) were also conducted. In comparison tests, bearings lubricated with PM212 had superior anti-wear characteristics compared to the baseline, unlubricated, super alloy bearings: No galling of PM212-lubricated bearings occurred, while severe surface damage including galling occurred, especially at high loads, during the baseline tests. A heat treatment procedure, which dimensionally stabilizes PM212 and thereby minimizes clearance changes during high temperature bearing operation, is described.

INTRODUCTION

The bearing material evaluated in this program is PM212. It is a powder metallurgy composite material that was invented at NASA Lewis Research Center (refs. 1 and 2). It has the same chemical composition as the previously reported plasma sprayed coating, PS212 (refs. 3 and 4). The composition contains metal-bonded chromium carbide, calcium fluoride/barium fluoride eutectic, and silver. PM212 has been prepared by cold die pressing followed by pressureless sintering (refs. 5 to 7), by hot pressing (ref. 7), and by extrusion of PM212 powder (ref. 8). PM212 prepared by all of these processes has shown promising tribological characteristics in pin on disk bench tests.

The encouraging results of the bench tests motivated the research reported in this paper to evaluate PM212 in a sliding bearing configuration. A plain cylindrical bearing design and an oscillating test mode were chosen for simplicity of bearing design and relevancy to potential applications for high-temperature bearings in the aerospace and ground transportation industries. Examples of such applications are variable stator bearings for gas turbine engines and components exposed to hot exhaust gases in internal combustion engines.

The cold press and sinter process was used to fabricate the test bearings. Preliminary bearing test results were reported in (ref. 9). Bearing torque and wear were favorable in these preliminary tests, but a major problem was the tendency of the PM212 to irreversibly swell and close the bearing to shaft diametral clearance during prolonged high temperature testing in air. Subsequently, a pretest heat treatment was devised to improve dimensional stability. The present paper reports the results of this effort and of the entire bearing test program to date.

Two types of plain cylindrical test bearings were tested: (1) monolithic bearings consisting entirely of PM212; and (2) clad bearings made of the super alloy Inconel 718 clad with PM212 which is sinter-bonded to the bearing bore.

The bearings were tested in sliding contact with Renè 41 journals oscillating $\pm 15^\circ$ at 42 cycles/minute. All tests were performed in room air. The scope of this program included bearing temperatures from 25 to 700 °C, long duration tests typically lasting 100 hr at a unit load of 3.45 Mpa (500 psi), and variable load tests at unit loads from 0.2 to 24.1 Mpa (30 to 3500 psi).

Baseline tests of unlubricated Inconel 718 bearings against Renè 41 journals were also performed for comparison with the PM212 bearings.

*Distinguished Research Associate—NASA Lewis Research Center.

MATERIALS

The chemical composition of the powder blend used to prepare PM212 is the following:

70 wt% metal bonded chromium carbide
15 wt% calcium fluoride/barium fluoride ($\text{CaF}_2/\text{BaF}_2$) eutectic
15 wt% silver (Ag).

The function of the carbide is to provide wear resistance, and the fluorides and silver are solid lubricants. The silver and metal-bonded chromium carbide are commercially procured. The particle size range of the silver powder is 44 to 150 μm , and that of the metal bonded carbide powder is 35 to 74 μm . The fluoride eutectic is made by pre-fusing a eutectic ratio (38/62 wt%) of calcium fluoride and barium fluoride at 1100 °C, followed by solidification cooling to room temperature. It is then mechanically crushed followed by further size reduction in a ball mill. The powder is then sieved to a particle size range of 44 to 150 μm .

BEARING FABRICATION

Two types of bearings were tested. They were fabricated to our specifications by the Advanced Materials Associates (ADMA) of Twinsburg, Ohio under the direction of their principal investigator, Dr. Vladimir S. Moxson. The monolithic bearings are made entirely of sintered PM212. The clad bearings consist of an Inconel 718 outer shell with a thin liner of PM212 that is sinter-bonded to the outer shell. The bearings are simple cylinders, nominally 13mm (0.50 in.) long with different bore diameters from 15.90 to 16.1 mm (0.626 to 0.632 in.). The René 41 shafts have a journal section diameter of 15.88 mm (0.625 in.) to give initial diametral clearances from 0.025 to 0.175 mm (0.001 to 0.007 in.). A photograph of the two bearing types is given in figure 1.

The monolithic bearings are made by first cold pressing PM212 powders into cylinders that are near the final bearing dimensions. The pressure is applied by the double acting die punches shown schematically in figure 2. The cold pressed parts are then pressureless sintered in a very dry hydrogen atmosphere (-50 °C dew point) at 1100 °C. Sintering is accomplished by placing the cold pressed blanks on a continuous conveyor which transports them through the controlled atmosphere furnace. The sintered bearings have a density of about 5.3 gms/cm³, or about 80 percent of theoretical density.

The final bore dimensions of the bearing are achieved by diamond grinding or diamond honing. Grinding with cubic boron nitride wheels can also produce a satisfactory bearing surface. Care must be taken to avoid selectively removing the soft lubricant components from the carbide matrix. A recommended grinding procedure is given in Table I. The non-sliding surfaces of PM212 may be machined with carbide cutting tools.

The clad bearings are fabricated in the same way, with the exception that the PM212 liners are cold pressed and sintered-bonded to the bores of Inconel 718 outer shells. The outer shell of the bearing is first placed into the die, then the PM212 powder is introduced into the annular gap between a centered core rod and the outer shell. There is a header gap above the bearing shell that allows sufficient powder to be introduced into the die assembly to totally fill the gap between the core die and the bearing shell after compaction. Bearings with PM212 liner thicknesses of 0.13, 0.38, and 0.76mm (0.005, 0.015, and 0.030 in.) were made in order to study the effect of liner thickness on bearing performance during prolonged exposure to high temperature air.

The thin cold pressed liners tended to fracture during removal of the bearing from the core rod, This problem was solved by using graphite mandrels as the segment of the core rod within the bearing. The graphite mandrel is left in the bearing during sintering. After cool down, the bearing is reheated, and the mandrel is then pressed out for reuse.

Heat treatment.—Early in the bearing test program, it was observed that a gradual loss of bearing to shaft diametral clearance occurred during planned, long duration (100 hr) tests (ref. 9). In a study of this problem, PM212 coupons of different thicknesses were heat treated in air at 750 °C; swelling and microstructural change were determined as a function of time at temperature (ref. 10). The swelling rate of PM212 decreased with time and approached zero after about 100 hr at temperature. Cross section micrographs of the coupons showed densification of PM212 to a depth of about 0.25 mm (0.01 in.). Therefore, in the present program, the bearings were heat treated to a steady

state microstructure, followed by light regrinding of the bearing bore to the desired diameter. The bearing test results to follow show that pre-heating in air at 750 °C for 100 hr or at 820 °C for 50 or 100 hr, followed by light grinding minimizes the loss of bearing clearance during high temperature testing.

The test shafts are made of René 41. The baseline unlubricated bearings and the outer shells of the PM212-clad bearings are made of Inconel 718. Both metals are nickel base alloys with hardness numbers of HRC 37±2. Their chemical compositions are given in Table II. Some relevant properties mechanical properties and the thermal expansion coefficients of PM 212, René 41, and Inconel 718 are given in Table III.

BEARING TEST PROCEDURE

An isometric drawing of the bearing test machine is shown in figure 3. The test bearing is lightly press fit into a self-aligning mounting as shown in figure 4(a) and (b). The René 41 test shaft is tapered to provide a nonslip locking fit into the drive shaft of the test machine.

A piezoelectric load cell in the drive arm senses the reversing driving force. The actuator moves at constant velocity over most of the stroke, and the shape of the torque trace is essentially in the form of a square wave: figure 5. The test is started with no applied load on the test bearing in order to measure the tare force due to frictional drag in the bearing test machine. A radial load is then applied to the test bearing. The resulting increase in drive force above the tare force is due to the friction in the test bearing plus a negligible increase in the friction of the oil-lubricated, rolling element support bearings. The increase in tangential force upon loading (corrected for the mechanical advantage of the crank moment arm relative to the test bearing radius) is therefore taken as the tangential frictional force in the test bearing. Test bearing friction coefficients are calculated by dividing this tangential force by the radial load on the bearing.

Two types of bearing test were conducted:

1. Long duration tests typically of 100 hr duration (252 kc at 42 cpm) at 3.45Mpa (500 psi) unit load.
2. Variable load tests: 0.2 to 24.1Mpa (30 psi to 3500 psi) unit loads increasing in 1.72 Mpa (250 psi) increments, each of 10 or 15 min duration

(Unit load is the absolute load per unit projected bearing area where the projected bearing area is the bearing length multiplied by the diameter of the bearing bore.)

Wear measurements.— The journal diameter and the inside (bore) diameter of the bearing are measured with a micrometer before and after test to determine any changes in diametral clearance. The maximum change in clearance in the load direction is expressed as the wear depth and this change per KC as the wear rate. A negative value indicates loss of clearance usually due to PM212 swell, while a positive value is the combined radial wear depth of the journal and the bearing. (Wear was not measured by the customary weight change method because weight increase due to oxidation at elevated temperature introduces significant error).

EXPERIMENTAL RESULTS

Long Duration Bearing Tests

Monolithic, sintered PM212 bearings.—Friction coefficients are given in Table IV. At room temperature, the friction coefficient is 0.39 early in the test, but gradually increases as wear debris accumulates in the bearing clearance. At test temperatures from 300 to 700 °C, friction coefficients are typically 0.25±0.02. Friction coefficients of heat treated bearings remain within this range for the entire test duration.

Diametral clearance changes are presented in Table IV. At room temperature, 300 and 400 °C, black wear debris is generated; wear is measurable on both the journal and bearing. Radial wear rates are 0.005mm/hr at room temperature, a moderate 0.0005mm/hr at 300 °C, and a very low 0.00005mm/hr at 400 °C. Although the wear rate at room temperature is relatively high, no galling or bearing seizure is observed. This is in contrast to the severe galling that occurs during baseline tests of unlubricated René 41 journals and Inconel 718 bearings, figure 6.

At 500, 600, and 700 °C, no wear debris is generated. Instead, a black glaze forms on the contact surfaces of the bearing and journal. No significant changes in bearing bore or journal diameters are detected by micrometer measurements of adequately heat treated bearings and journals tested for 100 hr or more. On the other hand, the swelling of PM212 in bearings that were not heat treated results in negative “wear rates,” a loss of clearance that eventually leads to increased bearing torque, and ultimately to bearing seizure. This usually limits bearing life to less than 100 hr for an initial clearance of 0.08 mm (0.003 in.).

Clad (PM212-lined) Inconel 718 bearings.—Friction coefficients are given in Table V. Within data scatter, friction coefficients are about the same as for the monolithic PM212 bearings at all test temperatures. The friction coefficient at room temperature is 0.36 for the first 3KC of oscillating cycles, then gradually increases as wear debris accumulates in the bearing clearance. The average friction coefficient for a total of ten tests at 400, 500, 600, and 700 °C is 0.22 with a standard deviation of ± 0.03 compared to 0.25 ± 0.02 for ten tests of monolithic PM212 bearings made entirely of sintered PM212.

No significant clearance changes occurred during high temperature testing of heat treated bearings. Some swelling occurred in the thin PM212 liners of bearings that were not heat treated prior to testing. The effect of heat treatment on clearance changes per KC of oscillation for both bearing designs is summarized in figure 10.

Variable Load Bearing Tests

A unit load of 3.45Mpa (500 psi) was chosen for the long duration tests because it is representative of unit loads on moderately loaded, oil-lubricated journal bearings used in applications such as air compressors and machine tools (11). However, some sliding contacts must withstand unit loads of 3000psi or higher in applications such as wrist pin and crankshaft bearings for reciprocating engines (refs. 11 and 12). Therefore, a limited number of variable load tests were performed to determine whether the PM212 bearings have load carrying capability at high temperatures comparable to oil-lubricated sliding contact bearings operating in high load applications at lubricant film temperatures typically less than 200 °C.

The results of the variable load tests are given in Table VI. Bearings were tested at 500, 600, and 700 °C at maximum unit loads from 17.2Mpa (2500 psi) to 24.1Mpa (3500 psi). None of the bearings failed in these tests. Within data scatter, friction coefficients did not vary with load. The arithmetic average and standard deviation are 0.23 ± 0.04 .

SEM/EDS Analyses

A scanning electron micrograph (SEM) of the wear debris from a PM212 bearing test at 400 °C is shown in Figure.8a. The electron dispersion spectrum (EDS) of the wear debris is shown in figure 8(b), and a difference spectrum, which is obtained by subtracting a spectrum for PM212 from that of the wear debris, is shown in figure 8(c). The remaining spectral peaks identify nickel, chromium, titanium, and oxygen. We interpret the difference spectrum to be that of oxidized wear debris from the René 41 journal. The strong titanium peak illustrates that this element preferentially oxidizes at the surface of René 41. As expected from wear measurements, the EDS analysis confirms that the wear debris contains material worn from both the bearing and the journal.

As previously stated, wear debris particles are not generated at test temperatures of 500 °C and higher. Instead, a black glaze is formed on the sliding surfaces. A low magnification photomicrograph of a glaze, which formed during a bearing test at 600 °C is shown in figure 9(a). An EDS spectrum of this glaze is shown in figures 9(b) and (c) is a difference spectrum obtained by subtracting a spectrum for oxidized René41 from figure 9(b). The difference spectrum gives the composition of the glaze, and shows that it contains the elements silver, calcium, and barium, but no nickel. This indicates that the glaze consists of solid lubricants preferentially transferred from the bearing to the journal.

Baseline Tests of Unlubricated Bearings

It is well known that “lubricious” oxides form on some turbine alloys in air at high temperatures (ref. 13). Therefore, Inconel 718 bearings were tested for comparison with PM212 bearings. The test conditions and results are summarized in Table VII. Friction coefficients as a function of temperature to 700°C are compared for PM212 bearings and Inconel 718 bearings in figure.11. From 500 to 700 °C, friction coefficients initially are only

marginally higher for Inconel 718 bearings than for PM212 bearings confirming the lubricious nature of the oxides formed on this alloy and the René 41 journals at high temperature. However, the unlubricated metals had a pronounced galling tendency, especially at high loads, generally accompanied by increased friction as the tests progressed. This tendency existed whether or not the metals were heat treated to preoxidize them before the bearing tests. Photomicrographs of René 41 journal surfaces that galled during baseline bearing tests are shown in figure 12.

CONCLUSIONS

1. Cylindrical PM212 journal bearings show promise for sliding contact applications at temperatures to 700 °C. Friction coefficients are typically around 0.36 ± 0.03 at room temperature, dropping to 0.24 ± 0.03 at 300 °C and remaining at that level to 700 °C. Wear rate is high at room temperature, (but galling does not occur), moderate at 300 °C, and low at 400 °C. At test temperatures from 500 to 700 °C, no wear at all is detectable by micrometer measurements of the bearing and journal after more than 200 000 oscillating cycles at a unit load of 3.4 Mpa (500 psi). It is concluded that PM212 bearings can be used in an oxidizing air atmosphere for applications in which the bearings are required to operate for long duration at high temperature, and a relatively short duration below 400 °C.

2. PM212 bearings must be heat treated in air in order to be dimensionally stable at high temperature. Otherwise the material tends to swell (probably due to oxidation) causing loss of diametral bearing clearance. Effective heat treatments are 100 hr at 750 °C or 100 hr at 820 °C.

3. A significant advantage of PM212 bearings is their non-galling characteristic. The baseline unlubricated metals, on the other hand, have a severe galling tendency at high bearing loads.

REFERENCES

1. Sliney, H. E., "Carbide, Fluoride, Silver Self-Lubricating Composite", U.S. Patent 4,728,448, Mar. 1, 1988.
2. Sliney, H. E. And DellaCorte, C., Method of Making Carbide/Fluoride/Silver Composites, U.S. Patent 5,034,187, Jul. 23, 1991.
3. Della Corte, C. And Sliney, H. E. , Composition Optimization of Self-Lubricating Chromium Carbide-Based Composite Coatings for Use to 760 °C, ASLE Trans. v.30, No. 1, Jan, 1987, 77-83.
4. Sliney, H. E., A New Chromium Carbide-Based Coating for Use to 900 °C with Particular Reference to the Stirling Engine, J. Vac. Soc. Technology, v. A 4, No. 6, Nov./Dec. 1986, 2629-2632.
5. DellaCorte, C. And Sliney, H.E., "Tribological Properties of PM212: A High-Temperature, Self- Lubricating Powder Metallurgy Composite, Lubr. Engr. 47, 4, 1991.
6. Sliney, H. E. , DellaCorte, C., and Lukaszewicz, V., The Tribology of PS212 Coatings and PM212 Composites for the Lubrication of Titanium 6-4-Al Components of a Stirling Engine Space Power System, STLE Tribology Transactions, vol. 38, (1995), No.3, 497-506.
7. Bogdanski, M. S., Sliney, H. E., and DellaCorte, C., The Effect of Processing and Compositional Changes on the Tribology of PM212 in Air, Lubr. Engr., vol. 51, No. 8, 675-683, 1995.
8. Waters, W. J., Sliney, H. E., Soltis, R. F., and Bemis, K., Properties of Extruded PS212 Type Self-Lubricating Materials. Proceedings of NASA Tech. 2002 Conference, Balt, MD, Dec. 1992., Published in NASA C.P.-3109, vol. 1, 41-55, Feb. 1993.
9. Sliney, H. E., "Test Results to 700 °C for Cylindrical PM212 Bearings"Proceedings of the 1992 Coatings for Advanced Heat Engines Workshop, Naval Post-Graduate School, Monterey, CA.,Sponsored by the Office of Transportation Technologies, DOE, pp. IV-27 to IV-43.

10. Bemis, K., Bogdanski, M., DellaCorte, C., and Sliney, H. E., The Effect of Prolonged Exposure to 750 °C Air on the Tribological Performance of PM212, NASA TM 106472, DOE/NASA/50306-4, 1994. And: STLE Tribology Trans., vol. 38, no.4, pp. 745-756, 1995.
11. Standard Handbook of Lubrication Engineering, O'Conner, J. J., Ed., McGraw Hill, N. Y., p18-3, 1968. From: Berard, S. J. , Waters, E. O., and Phelps, C. W.,Principles of Machine Design, Ronald Press, Co. , N.Y., p. 231.
12. Rippel, H. C., Cast Bronze Bearing Design Manual, Cast Bronze Bearing Inst., Cleveland, Oh., 1959.
13. Scott, F. H., and Wood, G. C., The Influence of Oxides on the Friction and Wear of Alloys, Tribol. Intl., Aug. 1978, p. 211.

TABLE I.—RECOMMENDED GRINDING PROCEDURE

1. Use diamond or cubic boron nitride grinding wheels or diamond honing on load-bearing sliding surfaces of PM212.
2. Use water as grinding coolant-use no oil.
3. Initial grinding cuts should be 0.025mm in depth.
4. Final cuts should be 0.01 to 0.015mm in depth. <ol style="list-style-type: none"> a. Taking too deep a cut, e.g., 0.1mm will pluck the softer solid lubricant phases from the surface. b. Taking too light a cut, e.g. Less than 0.01mm, will smear the metal-bonded chromium carbide. This results in an "orange peel" appearance of the surface .

TABLE II.—CHEMICAL COMPOSITIONS OF RENÉ 41 SHAFTS AND INCONEL 718 BEARING SHELLS

INCONEL 718:

Ni 50-55, Cr 17-21, Nb+Ta 4.8-5.5, Mo 2.8-3.3, Co 1.0, Ti 0.65-1.15, Al 0.2-0.8, C 0.08, Mn 0.35, Si 0.35, Co 0.3, S 0.01, P 0.15, B 0.006, Fe bal. (~14).

RENÉ 41:

Ni bal. (~50), Cr 18-20, Nb+Ta 0, Mo 9-10.5, Co. 10-12, Ti 3-3.3, Al 1.4-1.6, C 0.0p-0.12, Mn 0.1, Si 0.5, Fe 5.

TABLE III.—SOME RELEVANT PROPERTIES OF SHAFT AND BEARING MATERIALS

Property	PM 212	Material	
		René 41	Inconel 718
Thermal exponent coefficient., per °C	12.7×10 ⁻⁶ (25-550 °C) 13.8×10 ⁻⁶ (25-850 °C)	≈14-16×10 ⁻⁶ (25-627°C) ≈16-18×10 ⁻⁶ (25-927°C)	13×10 ⁻⁶ (25-100°C) 17.1×10 ⁻⁶ (25-870°C)
Hardness	Vickers DPH Ni: 570kg/mm ² Cr ₃ C ₂ :1300 "	38 HRC	38 HRC
Tensile strength Mpa (ksi)	45 (6.4) at 25 °C 25 (3.6) at 760 °C	1400 (203) at 25 °C 1314 (190) at 760 °C	1430 (208) at 25° 1276(185) at 760 °C
Compressive strength Mpa (ksi)	346 (50) at 25 °C 109 (16) at 760 °C	Approx. Equal to tensile properties	

TABLE IV.—TEST RESULTS FOR MONOLITHIC BEARINGS
(SINTERED PM212 BEARINGS)
[Air atmosphere, 3.45Mpa (500 psi) unit load oscillating $\pm 15^\circ$ at 0.012Hertz (42 \pm 2 cpm)]

Test temperature	Test duration	PM212 thickness	Heat treatment		Initial clearance	Clearance change	Steady state friction coefficient	Friction coefficient at end of test
			$^\circ\text{C}$	hr				
$^\circ\text{C}$	hr	mm	$^\circ\text{C}$	hr	mm	mm	μ_{ss}	μ_f
25	4.3	3	760	115	0.178	+0.013	0.37 \pm 0.04	0.52 (a)
25	150	3	-	-	0.178	+0.6	0.43 \pm 0.04	0.68 (a)
300	100	5	-	-	0.025	+0.102	0.24 \pm 0.03	0.27
400	100	5	-	-	0.025	+0.011	0.24 \pm 0.03	0.28
500	99	5	-	-	0.075	-0.114	0.24 \pm 0.03	0.40(b)
600	74	3	-	-	0.130	-0.203	0.23 \pm 0.02	0.42(b)
600	92	6	-	-	0.152	-0.178	0.23 \pm 0.04	0.40(b)
600	57(c)	6	760	71	0.152	-0.038	0.23 \pm 0.04	0.23
600	50(c)	6	760	90	0.076	0	0.23 \pm 0.04	0.24
700	99	3	760	90	0.145	-0.008	0.27 \pm 0.02	0.26
700	101	3	760	90	0.142	-0.142	0.27 \pm 0.03	0.33(b)
700	100	6	760	72	0.114	-0.008	0.29 \pm 0.02	0.36

- (a) Wear debris in bearing clearance increased friction as test progressed.
(b) Swelling of unheat-treated PM212 caused clearance loss that increased friction.
(c) Bearings OK. Tests shortened because of test rig malfunction.

TABLE V.—TEST RESULTS FOR CLAD BEARINGS
(PM 212- SELF-LUBRICATED LINERS IN INCONEL 718 SLEEVES)
Air atmosphere, 3.45 Mpa (500) psi unit load oscillating $\pm 15^\circ$ at 0.012 Hertz (42 \pm 2 cpm)

Test temperature	Test duration	PM212 liner thickness	Heat treatment		Initial clearance	Clearance change	Steady state friction coefficient	Friction coefficient at end of test
			$^\circ\text{C}$	hr				
$^\circ\text{C}$	hr	mm	$^\circ\text{C}$	hr	mm	mm	μ_{ss}	μ_f
25	1.2	0.13	-	-	0.07	+0.03	0.36 \pm 0.02	0.39(a)
25	52	0.13	820	100	0.09	+0.08	n.d.	-
400	115	0.13	-	-	0.07	+0.21	0.22 \pm 0.04	0.29
400	143	0.76	820	24	0.08	-0.04	0.20 \pm 0.04	0.19
500	101	0.76	820	24	0.08	-0.05	0.19 \pm 0.02	0.19
600	108	0.13	-	-	0.06	-0.07	0.22 \pm 0.04	0.23(b)
600	35	0.76	-	-	0.07	-0.08	0.29 \pm 0.09	0.75(c)
600	100	0.76	-	-	0.13	-0.05	0.22 \pm 0.05	0.19(b)
600	100	0.76	760	100	0.13	-0.05	0.20 \pm 0.03	0.19
600	210	0.76	760	100	0.06	-0.04	0.20 \pm 0.03	0.23
700	46	0.76	-	-	0.13	-0.15	0.26 \pm 0.03	0.35(c)
700	101	0.76	760	100	0.08	-0.04	0.19 \pm 0.03	0.18
700	101	0.76	760	162	0.05	-0.03	0.24 \pm 0.02	0.23
700	101	0.13	820	100	0.09	0	0.20 \pm 0.04	0.19
700	101	0.76	820	24	0.07	-0.02	0.22 \pm 0.02	0.24
700	112	0.76	820	54	0.13	0	0.24 \pm 0.02	0.24

(a) 107 cpm

(b) interference fit developed during post-test cool down

(c) interference fit developed during test causing premature test termination

TABLE VI.—VARIABLE LOAD TEST RESULTS FOR PM212-CLAD BEARINGS
Load increasing in 1.73 Mpa (250 psi) increments to the maximum indicated.

Test temperature	Test duration		PM212 thickness	Heat treatment		Max. unit load	Clearance	
							Initial	Change
$^\circ\text{C}$	hr	KC	mm	$^\circ\text{C}$	hr	Mpa (psi)	mm	mm
320	4.5	10.4	0.38	-	-	15.6 (2267)	0.076	+0.023
500	2.3	5.8	0.38	820	100	24.2 (3500)	0.084	-0.013
600	3.9	8.9	0.13	-	-	17.3 (2500)	0.069	-0.013
700	2.6	6.4	0.13	-	-	8.63 (1250)	0.076	-0.069 (a)
700	5.0	14.3	0.13	820	100	19.0 (2750)	0.178	0
700	8.0	23.8	0.13	820	100	20.7 (3000)	0.081	0

(a) Journal/bearing push fit post test.

TABLE VII.—BASELINE-UNLUBRICATED RENÉ 41 SHAFTS AND INCONEL 718 BEARINGS

Temperature	Duration	Preoxide?	Max. unit load		Friction coefficient		Clearance Initial change	
			°C	hr	Y/N	MPa	psi	Early, μ_0
25	23.8	N	3.44	500	.48-.56	.48-.56	.10 (4)	.04 (1.7)
25	74	Y	"	"	.50-.64	.64-.76	N.D.	
25	3.4	N	24.1	3500 max.	.43-.48	.48-.53	.14 (5.7)	.04(1.7)
300	2.3	N	"	"	.36-.44	.36-.44	Galled surfaces. Too rough to measure.	
500	2.2	Y	"	"	.22-.27	.25-.27		
500	2.1	Y	"	"	.32-.38	.38-.42		
500	2.3	Y	"	"	.25-.32	.25-.32		
500	2.2	N	"	"	.26	.55		
700	3.2	N	"	"	.23-.25	.23-.25		
700	2.2	N	"	"	.21-.33	.21-.33		

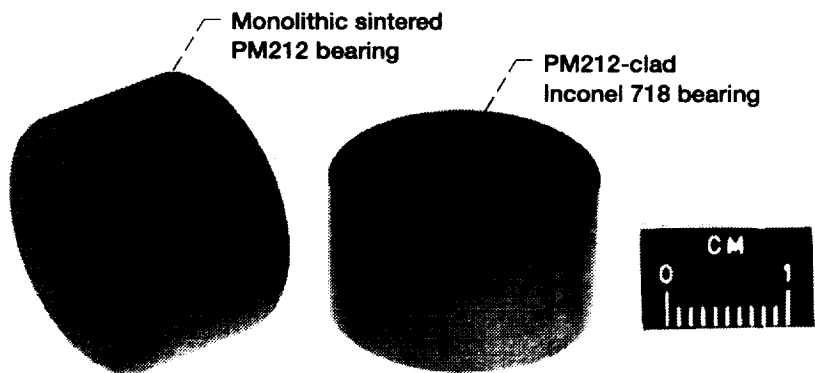

(a)

C-96-00829

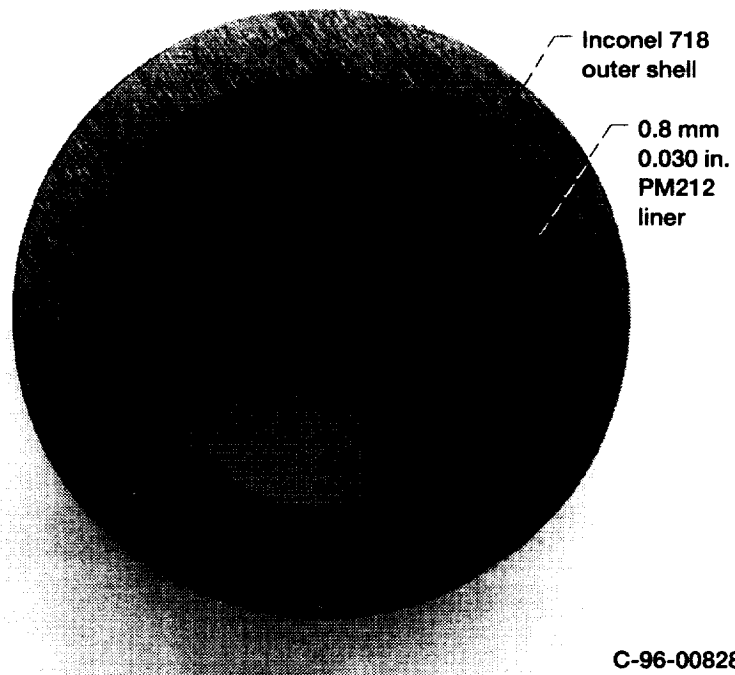

(b)

C-96-00828

Figure 1.—Test bearings. (a) Test bearings. (b) End view of PM212-clad bearing.

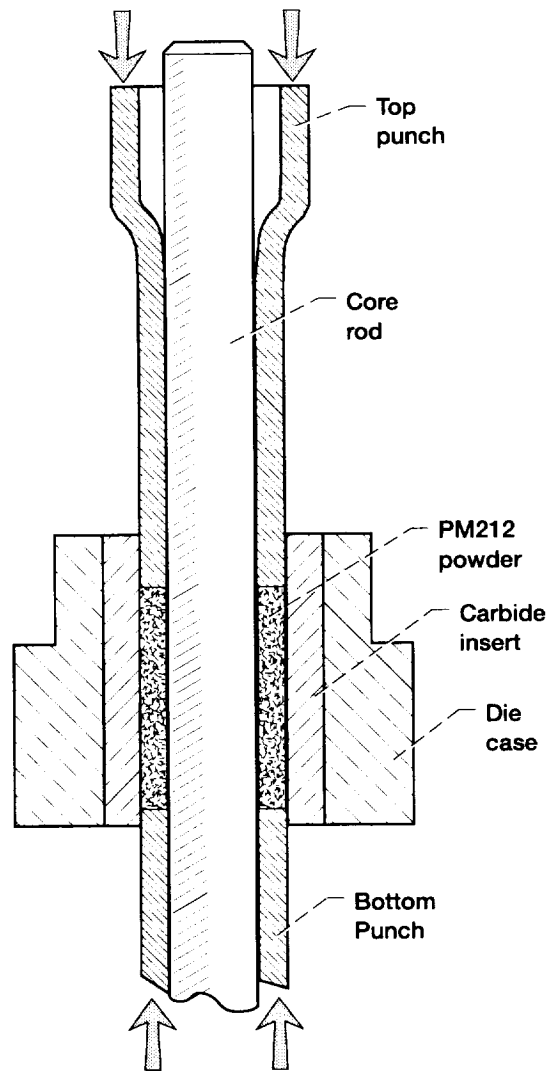

Figure 2.—Double acting die tooling for cold pressing monolithic PM212 bearing.

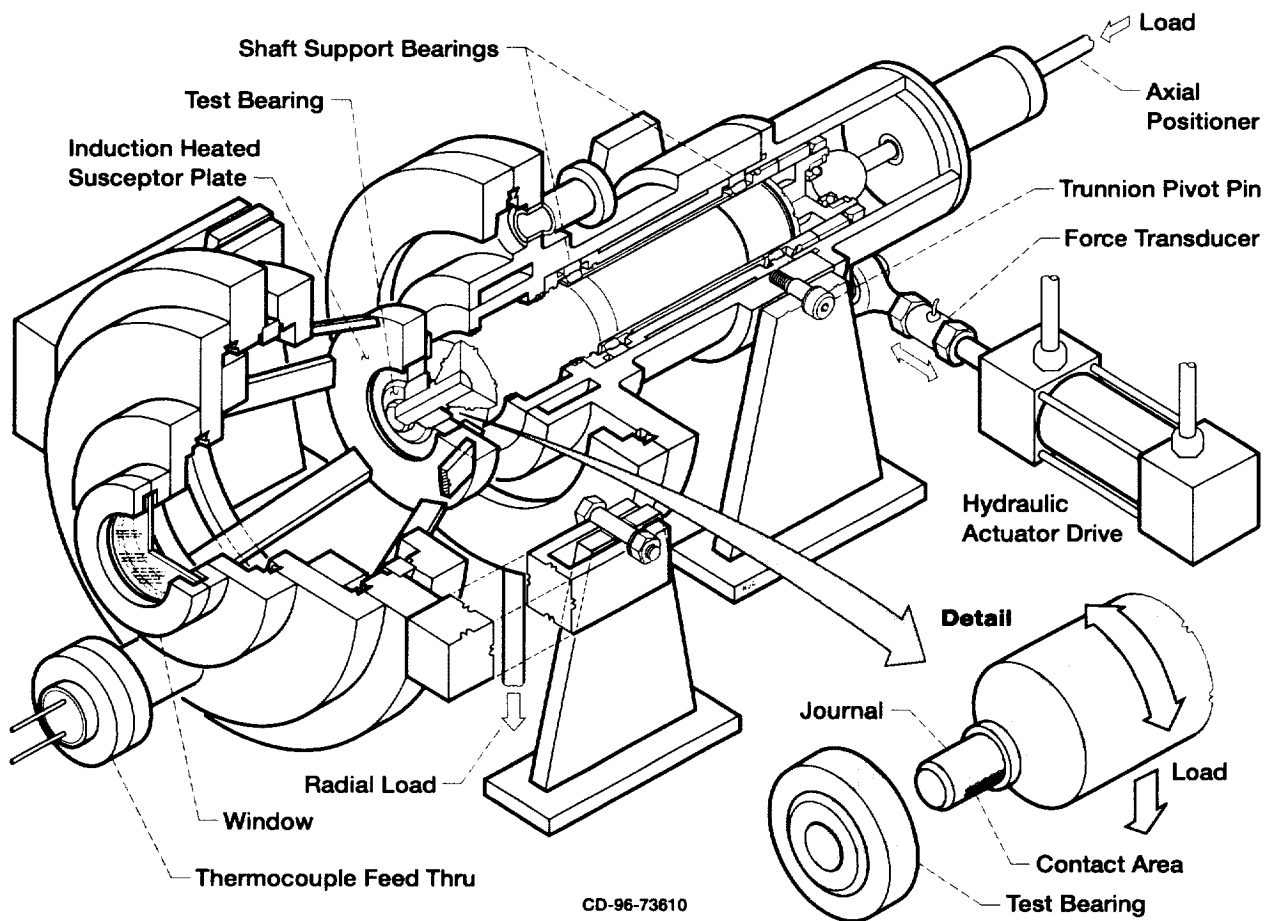
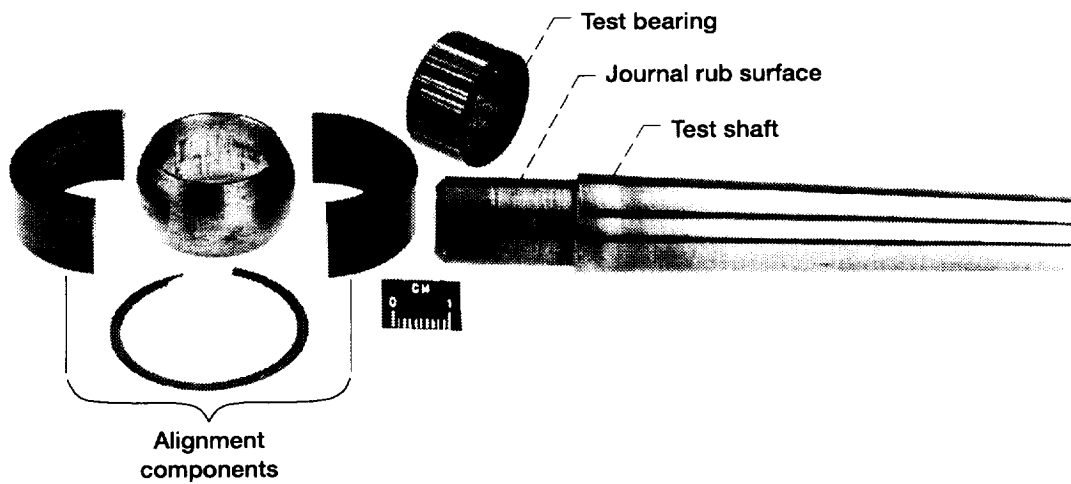
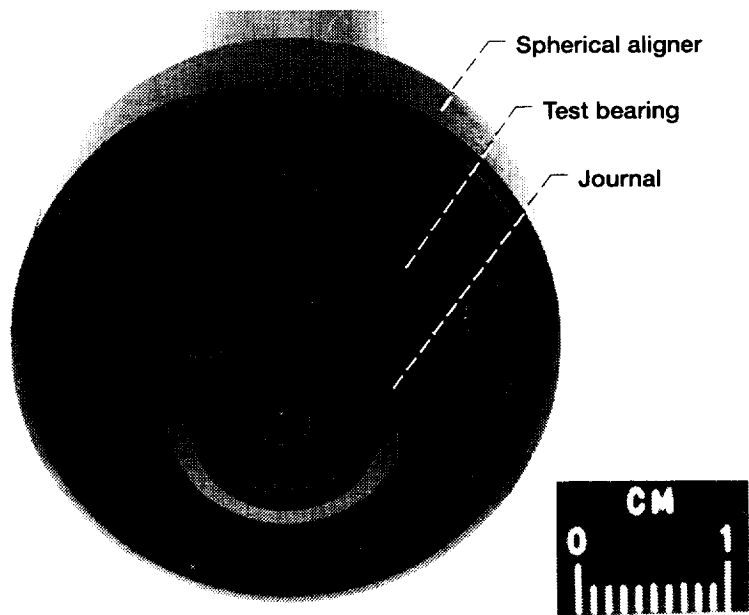

Figure 3.—High-temperature Oscillating Bearing Test Rig.



(a)

C-96-00829



(b)

C-96-00828

Figure 4.—Test components. (a) Bearing journal and alignment components. (b) Components assembled.

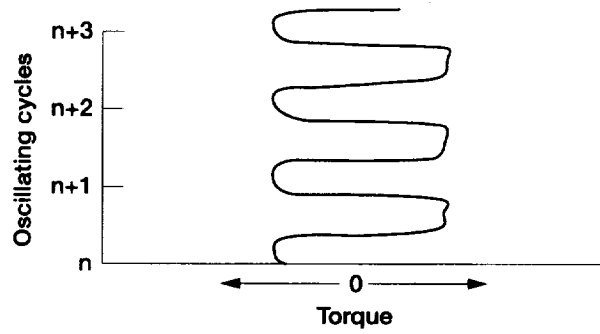

Figure 5.—Typical torque-time recorder trace.

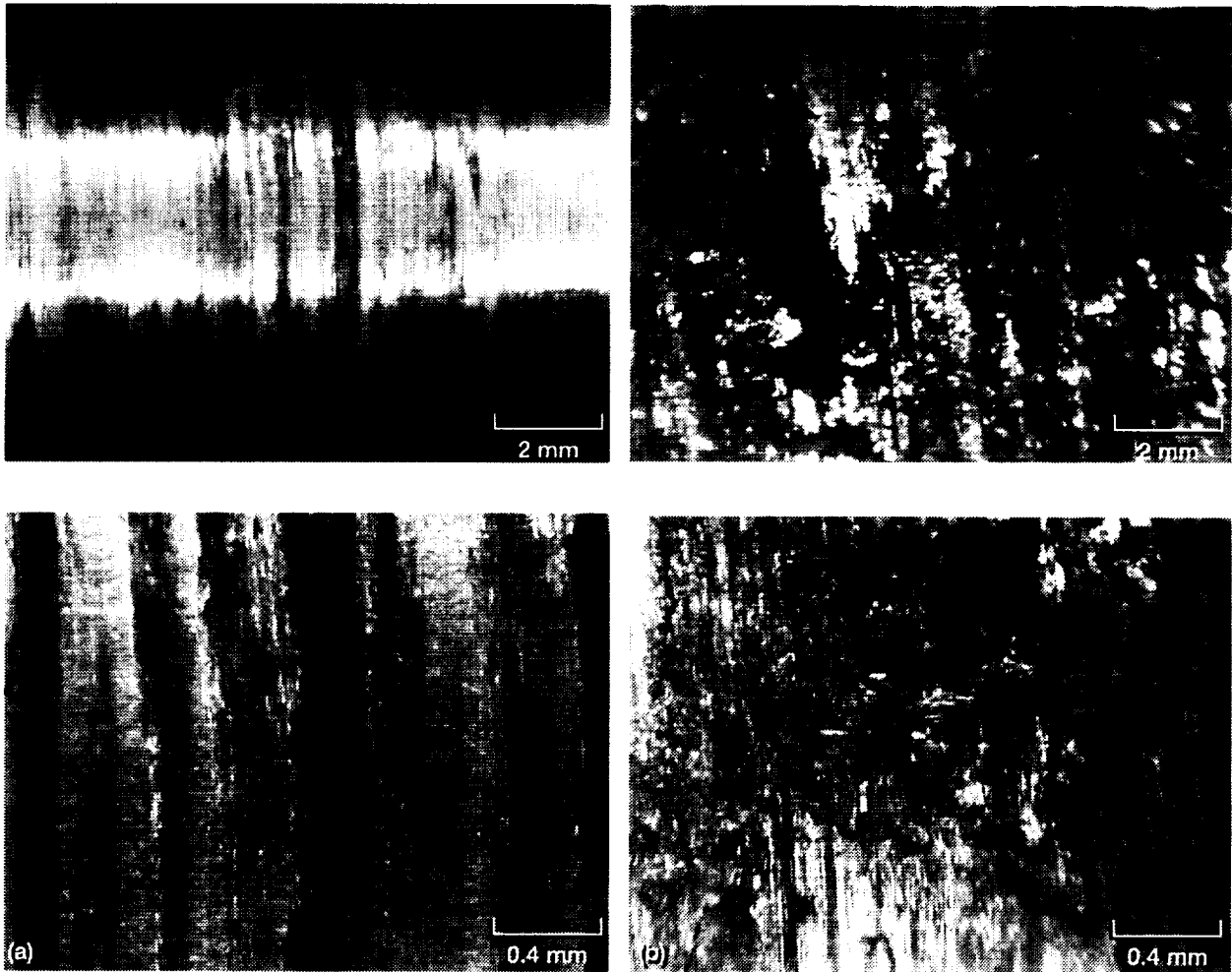

Figure 6.—Rub surfaces of René 41 journals after tests at room temperature against: (a) PM212 counterface. (b) Uncoated Inconel 718 counterface.

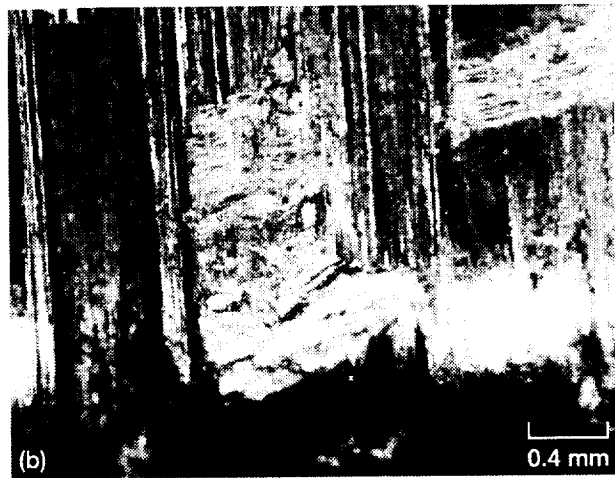
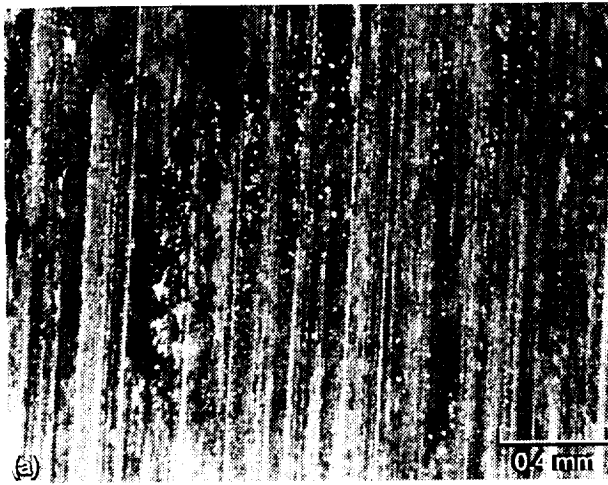
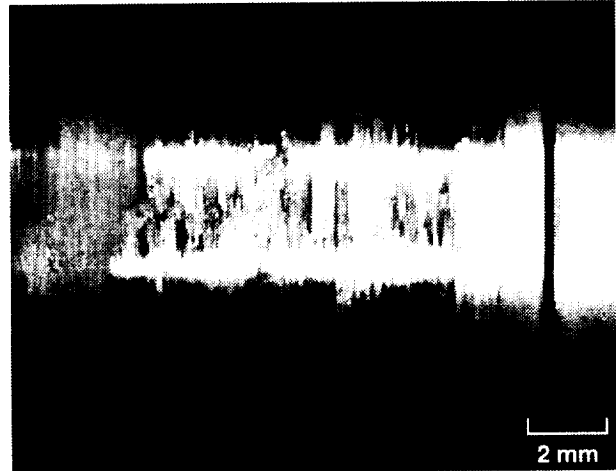
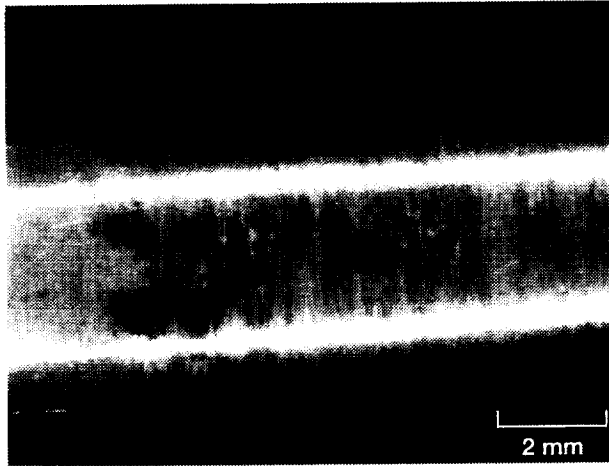
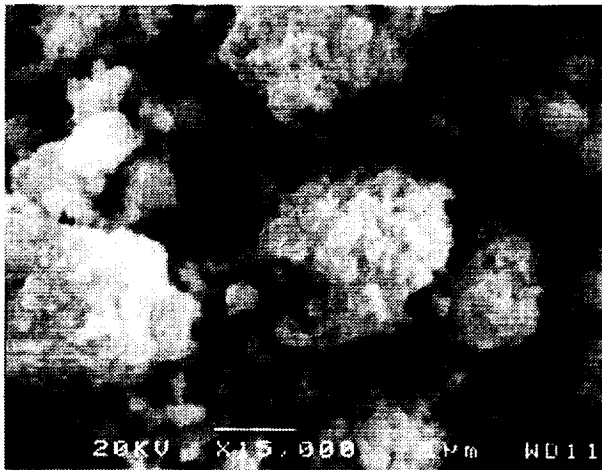
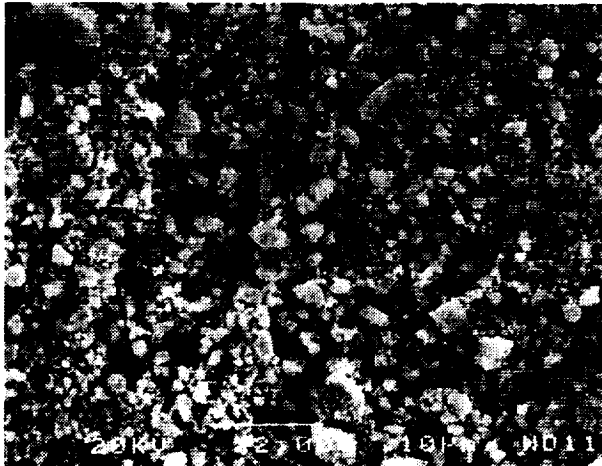

Figure 7.—Rub surfaces of René 41 journals after tests at 700 °C against: (a) PM212 counterface. (b) Uncoated Inconel 718 counterface.



(a)

Figure 8.—(a) Wear debris from a 400 °C PM212 bearing test.

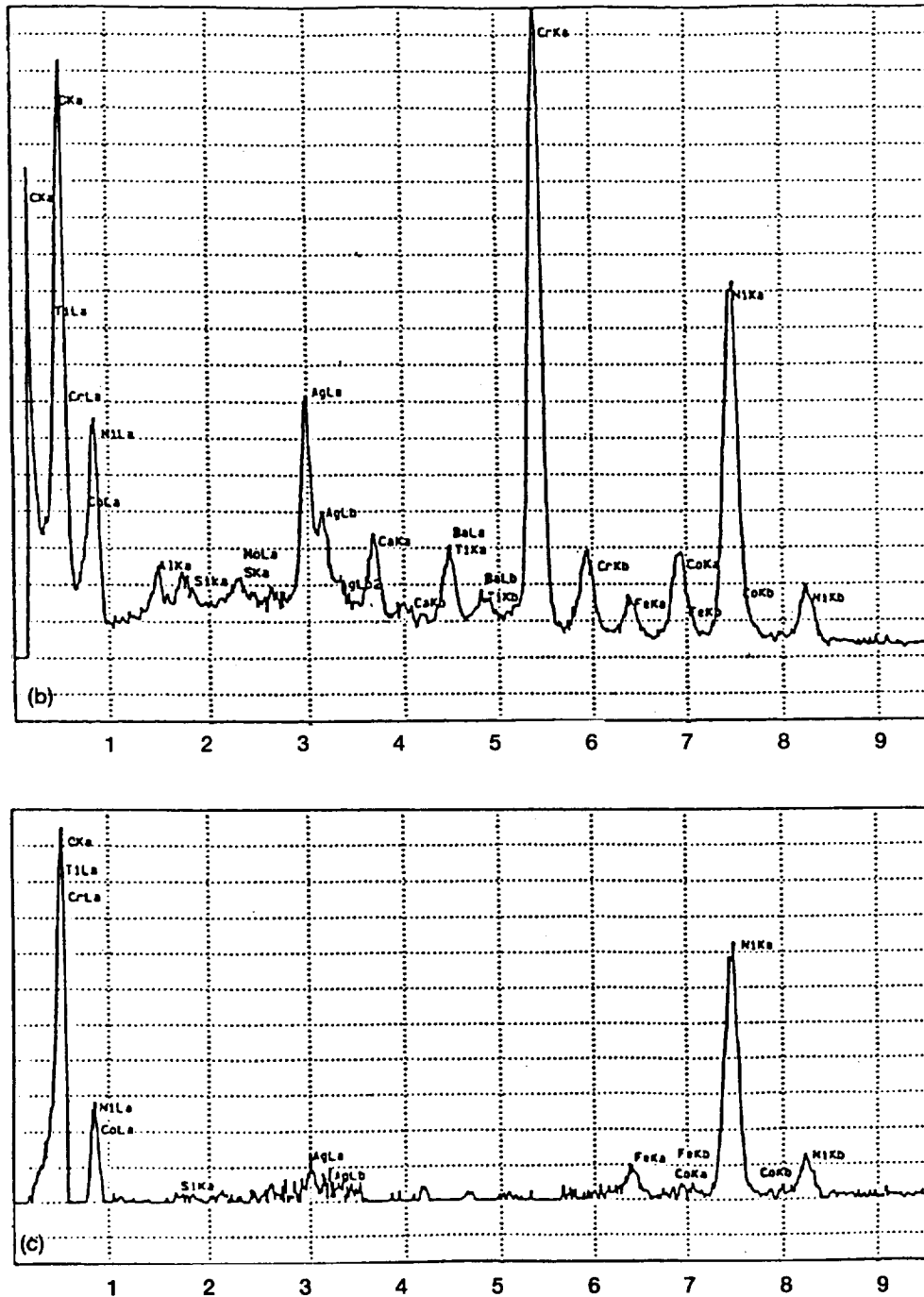
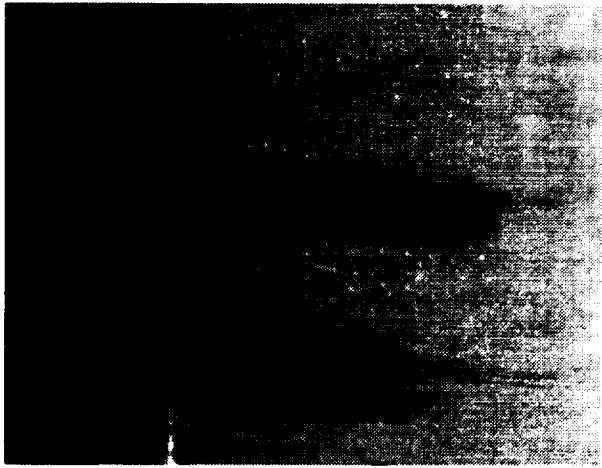

Figure 8.—Concluded. (b) Energy dispersive spectrum (EDS) of wear debris after PM212 bearing test of 100 hr, at 400 °C. (c) EDS difference spectra (Fig 8b minus PM212 spectra) for fraction of wear debris primarily from René 41 journal.



(a)

Figure 9.—(a) Transfer film on René 41 journal after 600 °C test of PM212 bearing. (a) Film on contact area.

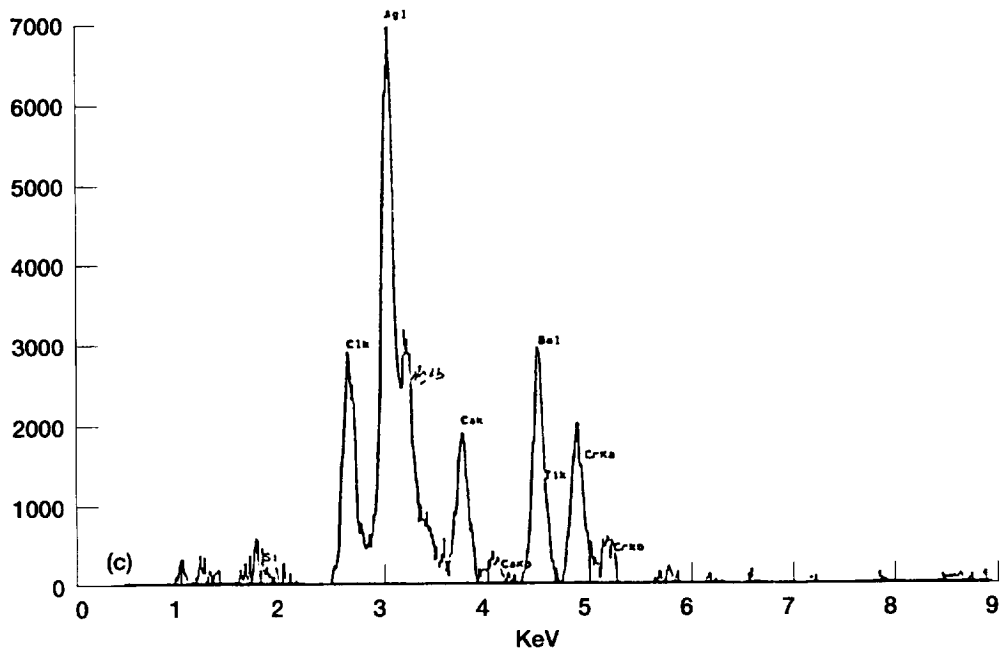
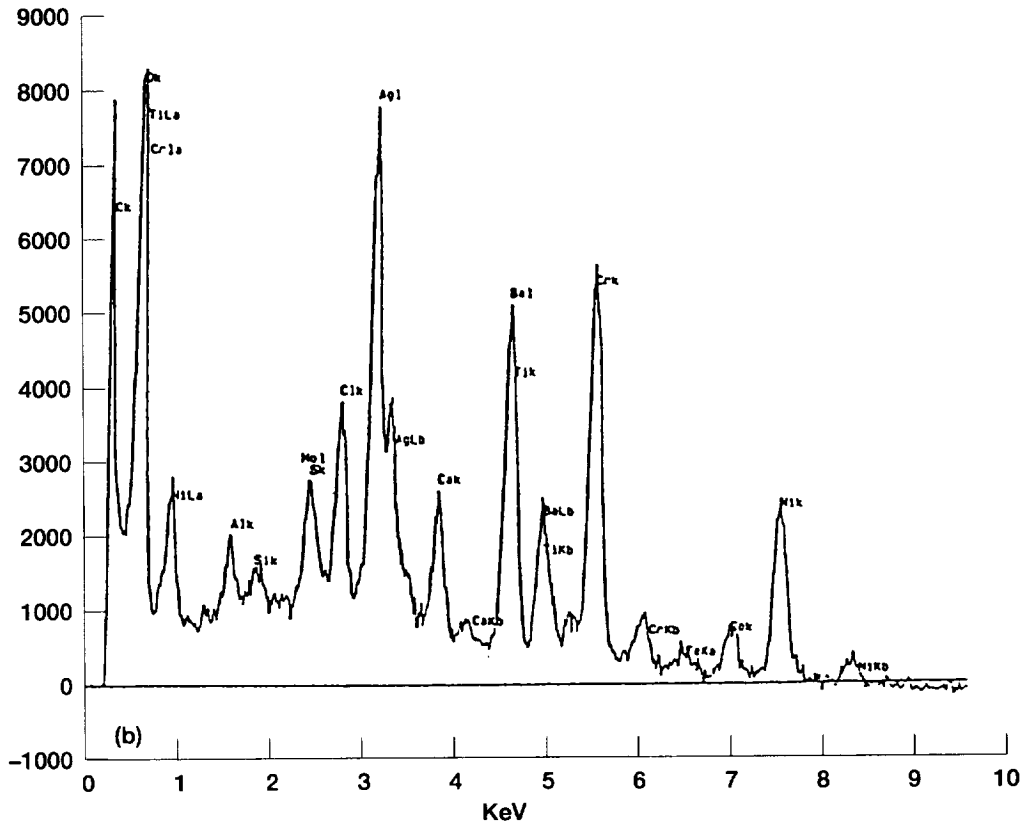

Figure 9.—Concluded. (b) Energy dispersive spectra (EDS) of contact area.
 (c) Difference EDS spectra of transfer film. (9b minus EDS of oxidized René 41.)

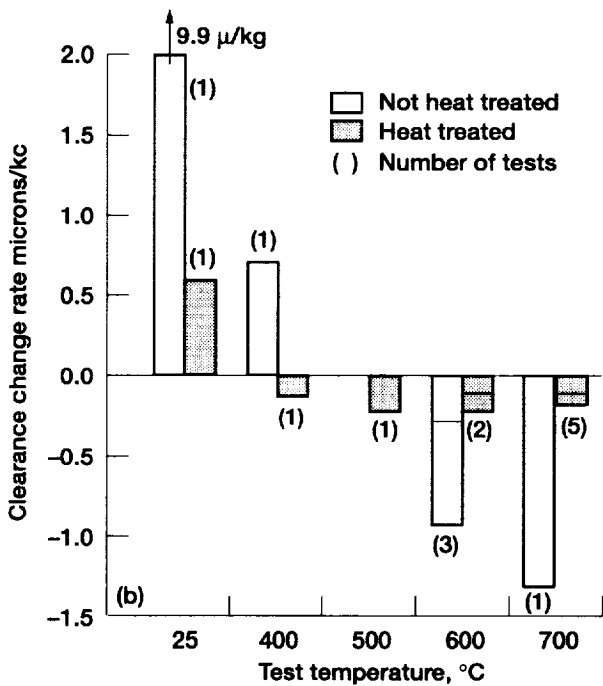
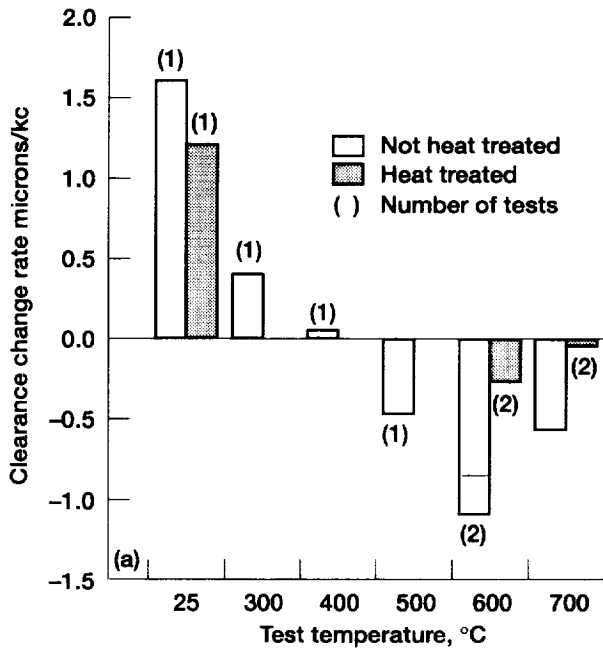

Figure 10.—Effect of heat treatment on radial clearance during tests at 3.45 MPa (500 psi) unit load. Heat treatment: (a) Monolithic PM212 bearings; 71 to 115 hr at 760 °C. (b) PM212-clad bearings; 100 hr at 760 or 820 °C or 24 hr at 820 °C.

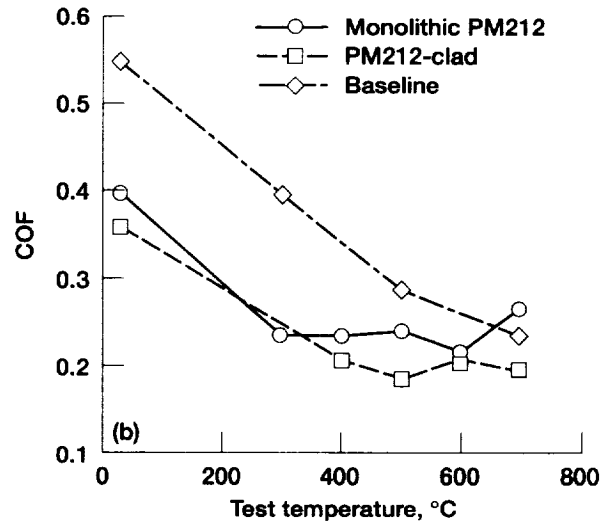

Figure 11.—Friction-temperature characteristics of PM212 bearing compared to baseline unlubricated bearings.

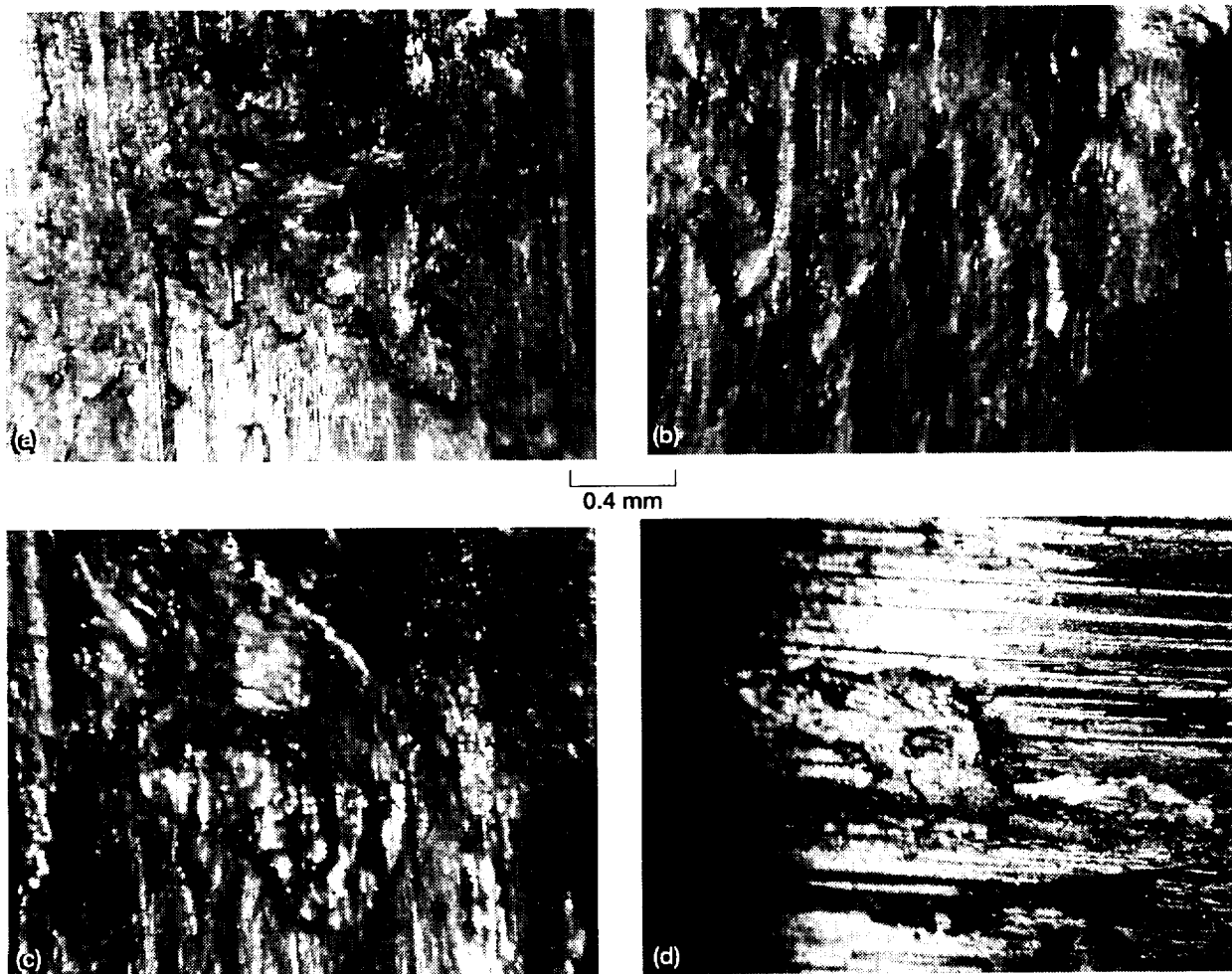

Figure 12.—Galled wear surfaces of René 41 journals after baseline tests against unlubricated Inconel 718 bearings at various temperature. (a) Room temperature. (b) 300 °C. (c) 500 °C. (d) 700 °C.

REPORT DOCUMENTATION PAGE

Form Approved
OMB No. 0704-0188

Public reporting burden for this collection of information is estimated to average 1 hour per response, including the time for reviewing instructions, searching existing data sources, gathering and maintaining the data needed, and completing and reviewing the collection of information. Send comments regarding this burden estimate or any other aspect of this collection of information, including suggestions for reducing this burden, to Washington Headquarters Services, Directorate for Information Operations and Reports, 1215 Jefferson Davis Highway, Suite 1204, Arlington, VA 22202-4302, and to the Office of Management and Budget, Paperwork Reduction Project (0704-0188), Washington, DC 20503.

1. AGENCY USE ONLY (Leave blank)	2. REPORT DATE September 1996	3. REPORT TYPE AND DATES COVERED Technical Memorandum	
4. TITLE AND SUBTITLE Sliding Contact Bearings for Service to 700 °C		5. FUNDING NUMBERS WU-505-63-5A	
6. AUTHOR(S) Harold E. Sliney		8. PERFORMING ORGANIZATION REPORT NUMBER E-10396	
7. PERFORMING ORGANIZATION NAME(S) AND ADDRESS(ES) National Aeronautics and Space Administration Lewis Research Center Cleveland, Ohio 44135-3191		10. SPONSORING/MONITORING AGENCY REPORT NUMBER NASA TM-107307	
9. SPONSORING/MONITORING AGENCY NAME(S) AND ADDRESS(ES) National Aeronautics and Space Administration Washington, DC 20546-0001		11. SUPPLEMENTARY NOTES Responsible person, Harold E. Sliney, organization code 5140, (216) 433-6055.	
12a. DISTRIBUTION/AVAILABILITY STATEMENT Unclassified - Unlimited Subject Categories 23, 24, and 37 This publication is available from the NASA Center for AeroSpace Information, (301) 621-0390.		12b. DISTRIBUTION CODE	
13. ABSTRACT (Maximum 200 words) Cylindrical, sliding contact bearings made entirely of a self-lubricating powder metallurgy composite (PM212) or of super alloy shells lined with clad PM212 were tested in an oscillating mode at temperatures from 25 to 700 °C. Tests of 100 hr duration or longer were conducted at a bearing unit load of 3.45 Mpa (500 psi). Shorter duration tests at various unit loads up to 24.1 Mpa (3500 psi) were also conducted. In comparison tests, bearings lubricated with PM212 had superior anti-wear characteristics compared to the baseline, unlubricated, super alloy bearings: No galling of PM212-lubricated bearings occurred, while severe surface damage including galling occurred, especially at high loads, during the baseline tests. A heat treatment procedure, which dimensionally stabilizes PM212 and thereby minimizes clearance changes during high temperature bearing operation, is described.			
14. SUBJECT TERMS Sliding contact bearings; High temperature dry bearings; PM212 tribocomposite bearings		15. NUMBER OF PAGES 24	
17. SECURITY CLASSIFICATION OF REPORT Unclassified		16. PRICE CODE A03	
17. SECURITY CLASSIFICATION OF REPORT Unclassified	18. SECURITY CLASSIFICATION OF THIS PAGE Unclassified	19. SECURITY CLASSIFICATION OF ABSTRACT Unclassified	20. LIMITATION OF ABSTRACT