

1N-63
0525

NASA Technical Memorandum 110287

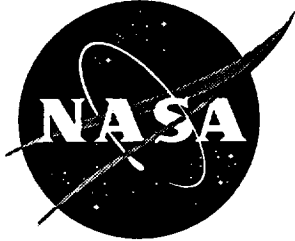

Robust Stabilization of a Class of Passive Nonlinear Systems

Suresh M. Joshi
Langley Research Center, Hampton, Virginia

Atul G. Kelkar
Kansas State University, Manhattan, Kansas

October 1996

National Aeronautics and
Space Administration
Langley Research Center
Hampton, Virginia 23681-0001

Summary

This paper addresses the problem of stabilization of a class of internally passive nonlinear dynamic systems using linear, time-invariant (LTI) passive controllers. Fundamental results on global asymptotic stability are obtained via Lyapunov-LaSalle method, using extensions of the Kalman-Yakubovich lemma. It is shown that a class of nonlinear time-invariant systems can be robustly stabilized by LTI controllers which are strictly positive real in the weak or marginal sense.

1 Introduction

Let \mathfrak{R} denote the set of real numbers, and \mathfrak{R}^n the n -dimensional Euclidian space. Let $\mathcal{L}_2 := \mathcal{L}_2[0, \infty)$ denote the Lebesgue space of real-valued functions of time t which are square-integrable on the interval $[0, \infty)$, and let \mathcal{L}_2^n denote the set of n -tuples of such functions. The truncation operator, P_T , is defined as the function

$$P_T(x(t)) = \begin{cases} x(t) & \text{for } t \leq T, \\ 0 & \text{for } t > T. \end{cases}$$

Let $x_T(t) := P_T(x(t))$ denote the truncation of $x(t)$. The set $\mathcal{L}_{2e}^n := \mathcal{L}_{2e}^n[0, \infty)$ denotes the set of all functions $x(t)$ whose truncations $x_T(t)$ are in \mathcal{L}_2^n for all finite T . \mathcal{L}_{2e}^n is called the extension of the space \mathcal{L}_2^n [1].

The inner product of x and y in \mathcal{L}_2^n is defined as:

$$\langle x, y \rangle = \int_0^\infty x^T(t)y(t)dt.$$

The norm of $x \in \mathcal{L}_2^n$ is defined as $\|x\| = (\langle x, x \rangle)^{\frac{1}{2}}$. The truncated inner product $\langle x, y \rangle_T$ is defined as:

$$\langle x, y \rangle_T = \langle x_T, y_T \rangle = \int_0^T x^T(t)y(t)dt.$$

The truncated norm of $x(t)$ is defined as: $\|x\|_T = \|x_T\|$.

We consider a class of nonlinear systems (denoted by Σ) affine in control, described by:

$$\begin{aligned} \dot{x} &= f(x) + g(x)u \\ y &= h(x) + N(x)u \end{aligned} \tag{1}$$

where the state vector $x \in \mathfrak{R}^n$, the input u and the output $y \in \mathcal{L}_{2e}^m$, $f(x) \in \mathfrak{R}^n$, $h(x) \in \mathfrak{R}^m$, $g(x) \in \mathfrak{R}^{n \times m}$, $N(x) \in \mathfrak{R}^{m \times m}$, and f, g, h, N smooth (i.e., infinitely differentiable, or C^∞) functions, and $f(0) = 0$, $h(0) = 0$.

We shall assume that the system Σ given by Eq. (1) is globally reachable and zero-state observable. These properties are defined next.

Reachability and Observability

Let $\Phi(t, x_0, u)$ denote the state transition map for initial state x_0 at $t = 0$ and input $u(t)$. A function $\sigma(\cdot)$ is said to belong to class K if it is strictly monotonic increasing and $\sigma(0) = 0$. Let \mathcal{B}_r denote the set $\{x \in \mathfrak{R}^n, \|x\| < r\}$.

Reachability: A system Σ is reachable if there exist a constant $r > 0$ and a class K function σ such that, for every $x \in \mathcal{B}_r$, there exist a finite $t_1 \geq 0$ and an input u , $\|u\|_\infty \leq \sigma(\|x\|)$, such that $x = \Phi(t_1, 0, u)$. If this holds $\forall x \in \mathfrak{R}^n$, Σ is globally reachable.

We shall assume in this paper that the system under consideration is globally reachable.

Zero-State Observability - A system, Σ is said to be locally zero-state observable if, with $u(t) \equiv 0$, there exists a neighborhood Ω of 0 such that $\forall x \in \Omega$

$$y = h(\Phi(t, x_0, 0)) = 0 \quad \forall t \geq 0 \Rightarrow x = 0. \quad (2)$$

Also, if $\Omega = \mathfrak{R}^n$ the system is said to be zero-state observable.

In addition, we shall introduce the following property which will be used in the stability proofs.

Strong Zero-State Observability: A system Σ is said to be strongly zero-state observable if it is zero-state observable, and has the property that $\{\lim_{t \rightarrow \infty} u(t) = 0$, and $\lim_{t \rightarrow \infty} y(t) = 0\}$ implies $\lim_{t \rightarrow \infty} x(t) = 0$.

2 Background

This section contains the relevant definitions of passivity, as well as the state space characterization of passive nonlinear and linear systems. Some stability results in the existing

literature are also given.

2.1 Passivity

The concept of passivity was first introduced in the network theory literature. In the context of electrical networks, passivity has the implication that any single-port network consisting solely of resistors, capacitors, and inductors constitutes a passive system. Similarly, for mechanical systems, any spring-mass-damper system with non-negative damping coefficients is passive.

Passivity can be defined in the input-output (IO) sense or in the internal sense [2]. The IO definition is more general and is applicable to a large class of systems including time-varying and infinite-dimensional systems.

Input-Output Passivity: A system is said to be passive in the IO sense if there exists a constant β such that

$$\langle u, y \rangle_T + \beta \geq 0 \quad \forall u \in \mathcal{L}_{2e}^m, \quad \forall T \geq 0 \quad (3)$$

Strict IO Passivity: A system is said to be strictly passive (or input strictly passive) in the IO sense if there exists a constant β and a constant $\epsilon > 0$ such that

$$\langle u, y \rangle_T + \beta \geq \epsilon \|u\|_T^2 \quad \forall u \in \mathcal{L}_{2e}^m, \quad \forall T \geq 0 \quad (4)$$

Internal passivity is usually defined for finite-dimensional systems, as follows.

Internal Passivity: The system (Σ) is said to be internally passive if there exists a nonnegative storage function $E[\cdot]$ such that

$$\langle u, y \rangle_T \geq E[x(T)] - E[x(0)] \quad \forall u \in \mathcal{L}_{2e}^m, \quad \forall T \geq 0. \quad (5)$$

Strict (or input-strict) passivity in the internal sense is defined similarly.

The difference between IO passivity and internal passivity is that a non-negative storage function (which is a function of the system's state vector) exists for the latter case. For finite-dimensional systems that are globally reachable and zero-state observable, IO passivity and internal passivity are equivalent.

We shall next present some passivity definitions for finite dimensional, linear, time-invariant (FDLTI) systems.

2.2 Passive FDLTI Systems

For finite-dimensional linear, time-invariant (FDLTI) systems, input-output passivity is equivalent to internal passivity of a minimal realization. The equivalence is a result of the Kalman-Yakubovich lemma[1]. Therefore, in the discussion of FDLTI systems, we shall use the term *passivity* to represent input/output passivity. For such systems, passivity is equivalent to “positive realness” of the transfer function [3], [4]. The concept of strict positive realness has also been defined in the literature, and is closely related to strict passivity.

Let $G(s)$ denote an $m \times m$ matrix whose elements are proper rational functions of the complex variable s . $G(s)$ is said to be stable if all its elements are analytic in $Re(s) \geq 0$. Let the conjugate-transpose of a complex matrix H be denoted by H^* .

Definition 1: An $m \times m$ rational matrix $G(s)$ is said to be

positive real (PR) if

- (i) all elements of $G(s)$ are analytic in $Re(s) > 0$;
- (ii) $G(s) + G^*(s) \geq 0$ in $Re(s) > 0$; or equivalently,
 - (iia) poles on the imaginary axis are simple and have nonnegative-definite residues,

and

- (iib) $G(j\omega) + G^*(j\omega) \geq 0$ for $\omega \in (-\infty, \infty)$.

Given below are some definitions of *strictly* positive real (SPR) systems found in the literature. Definition 2, which represents the specialization of the general definition of strict passivity to stable LTI systems, is the strongest definition of strict positive realness.

Definition 2: An $m \times m$ stable rational matrix $G(s)$ is said to be *strictly passive* if there exists an $\epsilon > 0$ such that

$$G(j\omega) + G^*(j\omega) \geq \epsilon I \text{ for } \omega \in (-\infty, \infty).$$

Strictly passive systems require the system to have a relative degree of zero, which makes this a very restrictive class of systems.

Definition 3 (ref. [7]): An $m \times m$ stable rational matrix $G(s)$ is said to be *strictly positive real in the weak sense* (weak SPR, or WSPR) if

$$G(j\omega) + G^*(j\omega) > 0 \text{ for } \omega \in (-\infty, \infty).$$

A stronger definition of SPR was given in [5], [6], which requires certain additional conditions. Definitions 2 and 3 assume stable systems. The following definition, introduced in [8], allows the system to have poles *on* the imaginary axis.

Definition 4 (ref. [8]): An $m \times m$ rational matrix $G(s)$ is said to be *marginally strictly positive real* (MSPR) if it is positive real, and

$$G(j\omega) + G^*(j\omega) > 0 \text{ for } \omega \in (-\infty, \infty).$$

Definition 4 of MSPR differs from Definition 1 (PR) because the frequency domain inequality (\geq) has been replaced by the strict inequality ($>$). The difference between Definitions 3 and 4 is that the latter allows $G(s)$ to have poles on the imaginary axis. Thus Definition 4 gives the least restrictive class of SPR systems. If $G(s)$ is MSPR, it can be expressed as: $G(s) = G_1(s) + G_2(s)$, where $G_2(s)$ is WSPR and all the poles of $G_1(s)$ (in the Smith-McMillan sense) are purely imaginary [8].

2.3 State-Space Characterization of Passive Systems

The following theorem ([9], [2], [10]) gives the necessary and sufficient condition for a system to be internally passive, and is the nonlinear version of the well-known Kalman-Yakubovich lemma.

Theorem 1 *The nonlinear system (1) is internally passive if and only if there exists a non-negative function $E(x) \in C^1$, $E(0) = 0$, and functions $l(x) \in \mathbb{R}^k$, and $W(x) \in \mathbb{R}^{k \times m}$ for some integer k such that*

$$\begin{aligned} \nabla^T E(x) f(x) &= -l^T(x) l(x) \\ g^T(x) \nabla E(x) &= h(x) - 2W^T(x) l(x) \\ W^T(x) W(x) &= \frac{1}{2}[N(x) + N^T(x)]. \end{aligned} \tag{6}$$

For FDLTI systems, Theorem 1 results in the Kalman-Yakubovich lemma. In [7], the Kalman-Yakubovich lemma was extended to WSPR systems, and in [8], it was extended to MSPR systems. These extensions are given next. $([A, B, C, D])$ denotes an n th-order minimal realization of the $m \times m$ transfer function matrix $G(s)$.

Lemma 1 (ref. [7]) $G(s)$ is WSPR if and only if there exist real matrices: $P = P^T > 0, P \in \mathfrak{R}^{n \times n}, L \in \mathfrak{R}^{m \times n}, W \in \mathfrak{R}^{m \times m}$ such that

$$A^T P + P A = -L^T L \quad (7)$$

$$C = B^T P + W^T L \quad (8)$$

$$W^T W = D + D^T \quad (9)$$

where $[A, B, L, W]$ is minimal and $F(s) = W + L(sI - A)^{-1}B$ is minimum phase.

Proof The proof can be found in [7]. \square

Let $[A_2, B_2, C_2, D]$ denote an n th-order minimal realization of $G_2(s)$, the stable part of $G(s)$. The following lemma is an extension of the Kalman-Yakubovich lemma to the MSPR case.

Lemma 2 (ref. [8]) If $G(s)$ is MSPR, there exist real matrices: $P = P^T > 0, P \in \mathfrak{R}^{n \times n}, \mathcal{L} \in \mathfrak{R}^{m \times n_2}, W \in \mathfrak{R}^{m \times m}$ such that Eqs. (7)-(9) hold with

$$L = [0_{m \times n_1}, \mathcal{L}_{m \times n_2}] \quad (10)$$

where $[A_2, B_2, \mathcal{L}, W]$ is minimal and $F(s) = W + L(sI - A)^{-1}B = W + \mathcal{L}(sI - A_2)^{-1}B_2$ is minimum-phase.

Proof Refer to [8]. \square

Only the sufficiency part is given in this lemma because it is of relevance in obtaining the stability results to be presented. Also note that in both WSPR and MSPR cases, the storage function is given by $E(x) = \frac{1}{2}x^T P x$, where x is the state vector of a minimal realization of $G(s)$.

2.4 Previous Stability Results

Stability analysis of the negative feedback interconnection of two passive systems has long been a topic of considerable interest. The best-known stability result for such systems

is the Passivity Theorem, which states that the negative feedback interconnection of a passive system and a strictly passive system is finite-gain (or \mathcal{L}_2)-stable (e.g., see [1]). If the systems are internally passive, globally reachable, and zero-state observable, then the feedback interconnection is globally asymptotically stable [2]. The requirement of strict passivity, however, is too restrictive. In particular, a strictly passive system requires a direct feedthrough term in the output equation (i.e., the relative degree has to be zero). It is, therefore, highly desirable to weaken the requirement of strict passivity.

To that effect, in the case of FDLTI systems, the requirement of strict passivity was weakened in [7] and [8]. It was shown in [8] that the negative interconnection of a PR system $[H(s)]$ and an MSPR system $[G(s)]$ is asymptotically stable if none of the $j\omega$ -axis poles of $G(s)$ is a transmission zero of $H(s)$. The stability holds regardless of the presence of unmodeled dynamics and parametric uncertainty in the systems, and is therefore robust. A special case occurs when $G(s)$ is WSPR, and for that case, the resulting feedback loop is also asymptotically stable, as was stated in [7].

We shall next extend the stabilization results of [7] and [8] to nonlinear passive systems in a negative feedback loop with passive FDLTI systems.

3 Stabilization of Passive Nonlinear Systems Using LTI Controllers

Consider the system shown in Figure 1, which represents the negative feedback interconnection of a passive nonlinear system and an LTI system. The following theorems establish global asymptotic stability of the feedback system under weaker conditions, i.e., when one of the systems is passive, and the other is linear and WSPR or MSPR.

Theorem 2 *Suppose in the system shown in Figure 1, Σ is affine in control (see (1)), internally passive, strongly zero-state observable, and has a radially unbounded storage function $E(x)$. Then the feedback system is globally asymptotically stable if the system $G(s)$ is WSPR.*

Proof 2 Let x denote the n -dimensional state vector of Σ and \hat{x} denote the \hat{n} -dimensional state vector of a minimal realization $[A, B, C, D]$ of $G(s)$. Since $G(s)$ is WSPR, from [7],

there exist matrices $P = P^T > 0$, $P \in \mathfrak{R}^{\hat{n} \times \hat{n}}$, $L \in \mathfrak{R}^{m \times \hat{n}}$, $W \in \mathfrak{R}^{m \times m}$, such that Eqs. (7)-(9) are satisfied, and $[A, B, L, W]$ is minimal and $F(s) = W + L(sI - A)^{-1}B$ is minimum-phase.

Consider the candidate Lyapunov function

$$V(x, \hat{x}) = E(x) + \hat{E}(\hat{x})$$

where $\hat{E}(\hat{x}) = \frac{1}{2}\hat{x}^T P \hat{x}$ is the storage function of $G(s)$. Note that $E(x)$ is positive definite because the system is zero-state observable [2]. Differentiation of $V(t)$ with respect to t and simplification using (1), and (6)-(9) leads to

$$\dot{V} = -d(x, u) + y^T u - z^T z + \hat{y}^T \hat{u} \quad (11)$$

where

$$d(x, u) = [l(x) + W(x)u]^T [l(x) + W(x)u]$$

and

$$z(t) = \frac{1}{\sqrt{2}}[L\hat{x} + W\hat{u}].$$

Noting that $u = -\hat{y}$, $\hat{u} = y$, we have

$$\dot{V} = -d(x, u) - z^T z \leq 0 \quad (12)$$

i.e., \dot{V} is negative semi-definite, and the closed-loop system is at least Lyapunov-stable. However, we will show that the closed-loop system is, in fact, globally asymptotically stable.

We have established so far that $\dot{V} \leq 0$. Now, $\dot{V} \equiv 0 \Rightarrow d(x(t), u(t)) \equiv 0$, and $z(t) \equiv 0$. However, $z(t)$ is the output (produced by the input $\hat{u}(t)$) of the system: $\hat{F}(s) = \frac{1}{\sqrt{2}}[W + L(sI - A)^{-1}B]$, which has transmission zeros only in the open left-half plane. Therefore, $\hat{u}(t) \rightarrow 0$ exponentially, i.e., $y(t) \rightarrow 0$. Since $G(s)$ is stable, $\hat{u}(t) \rightarrow 0 \Rightarrow \hat{y}(t) \rightarrow 0$. That is, $u(t) \rightarrow 0$ and $y(t) \rightarrow 0$. Since Σ is strongly zero-state observable and $[A, B, C, D]$ is minimal, $u(t), y(t) \rightarrow 0 \Rightarrow x(t) \rightarrow 0$, and $\hat{x} \rightarrow 0$, i.e., $\|x(t)\| \rightarrow 0$, $\|\hat{x}(t)\| \rightarrow 0$. This implies that $V(x(t), \hat{x}(t)) \rightarrow 0$, i.e., it shows that $V(x(t), \hat{x}(t))$ decreases ($\dot{V} < 0$) somewhere along the trajectories implying that $\dot{V} \not\equiv 0$. Therefore, such trajectories cannot exist, and by LaSalle's invariance principle, the feedback system is globally asymptotically stable. \square

The conditions of Theorem 2 can be relaxed to allow the system $G(s)$ to have poles on the imaginary axis. However, this requires the nonlinear system Σ to satisfy an additional condition. The following theorem gives the conditions under which the feedback interconnection of a passive system and an MSPR system is globally asymptotically stable.

Theorem 3 *Suppose in the system shown in Figure 1, Σ is affine in control, internally passive, strongly zero-state observable, and has a radially unbounded storage function $E(x)$. In addition, suppose Σ has the property that $u(t) \notin \mathcal{L}_2[0, \infty) \Rightarrow \lim_{t \rightarrow \infty} y(t) \neq 0$. Then the closed-loop system is globally asymptotically stable if $G(s)$ is MSPR.*

Proof 3 Proceeding as in the proof of Theorem 2, suppose x denotes the n -dimensional state vector of Σ and \hat{x} denote the \hat{n} -dimensional state vector of a minimal realization $[A, B, C, D]$ of $G(s)$. Let n_2 denote the number of poles of the stable part $G_2(s)$ of $G(s)$, and let $[A_2, B_2, C_2, D]$ denote its minimal realization. Since $G(s)$ is MSPR, from Lemma 2, there exist matrices $P = P^T > 0$, $P \in \mathfrak{R}^{n \times n}$, $\mathcal{L} \in \mathfrak{R}^{m \times n_2}$, $W \in \mathfrak{R}^{m \times m}$, such that Eqs. (7)-(10) are satisfied, and $[A_2, B_2, \mathcal{L}, W]$ is minimal and minimum-phase.

Consider the candidate Lyapunov function

$$V(x, \hat{x}) = E(x) + \hat{E}(\hat{x})$$

where $\hat{E}(\hat{x}) = \frac{1}{2} \hat{x}^T P \hat{x}$ is the storage function of $G(s)$. Using Eqs. (6)-(10) and proceeding as in the proof of Theorem 2, the time derivative of V can be obtained as

$$\dot{V} = -d(x, u) + y^T u - z^T z + \hat{y}^T \hat{u} \quad (13)$$

where

$$d(x, u) = [l(x) + W(x)u]^T [l(x) + W(x)u]$$

and

$$z(t) = \frac{1}{\sqrt{2}} [L\hat{x} + W\hat{u}] = \frac{1}{\sqrt{2}} [\mathcal{L}\hat{x}_2 + W\hat{u}]$$

where \hat{x}_2 is the state vector corresponding to $[A_2, B_2, C_2, D]$. Noting that $u = -\hat{y}$, $\hat{u} = y$, we have

$$\dot{V} = -d(x, u) - z^T z \leq 0 \quad (14)$$

i.e., \dot{V} is negative semi-definite, and the closed-loop system is at least Lyapunov-stable. However, we will show that the closed-loop system is, in fact, globally asymptotically stable.

$\dot{V} \equiv 0 \Rightarrow d(x(t), u(t)) \equiv 0$, and $z(t) \equiv 0$. However, $z(t)$ is the output (produced by the input $\hat{u}(t)$) of the system: $\hat{F}(s) = \frac{1}{\sqrt{2}}[W + \mathcal{L}(sI - A_2)^{-1}B_2]$, whose transmission zeros are in the open left-half plane. Therefore, $\hat{u}(t) \rightarrow 0$ exponentially, i.e., $y(t) \rightarrow 0$. Therefore, $\hat{y}(t)$ can consist only of exponentially decaying terms, and sinusoidal terms (including zero-frequency) corresponding to the $j\omega$ -axis poles of $G(s)$. If $\hat{y}(t)$ consists of any sinusoids, then $\hat{y}(t) \notin \mathcal{L}_2[0, \infty)$, which implies that $y(t)$ cannot go to zero; this contradicts the fact that $y(t) \rightarrow 0$; therefore, $y(t)$ can consist only of exponentially decaying terms. Since Σ is strongly zero-state observable and $[A, B, C, D]$ is minimal, $u(t)$ and $y(t) \rightarrow 0 \Rightarrow x(t) \rightarrow 0$, and $\hat{x}(t) \rightarrow 0$. The rest of the proof is the same as that of Theorem 2. \square

In Theorem 2, the requirement that $u(t) \notin \mathcal{L}_2[0, \infty) \Rightarrow \lim_{t \rightarrow \infty} y(t) \neq 0$ will usually be satisfied if the zero dynamics of Σ are asymptotically stable.

4 Concluding Remarks

The problem of robust stabilization of a class of nonlinear passive systems was considered. It was shown that, under the assumption of strong observability, a class of internally passive nonlinear systems can be stabilized by a class of linear, time-invariant passive controllers. The stability holds regardless of the presence of unmodeled modes or parametric uncertainties, and is therefore *robust*.

References

- [1] M. Vidyasagar, *Nonlinear Systems Analysis*, N.J.: Prentice-Hall, 1993.
- [2] Hill, D. J., "Nonlinear Controller Design Using Passivity and Small Gain Techniques", 1994 IEEE CDC Workshop, Orlando, Florida, December 1994.
- [3] R. W. Newcomb, *Linear Multiport Synthesis*, New York: McGraw-Hill, 1966.

- [4] C. A. Desoer and M. Vidyasagar, *Feedback systems: Input-Output Properties*. New York: Academic, 1975.
- [5] J. H. Taylor, "Strictly Positive Real Functions and Lefschetz-Kalman-Yakubovich (LKY) Lemma", *IEEE Trans. Circuits Syst.*, March 1974, pp. 310-311.
- [6] P. Ioannou and G. Tao, "Frequency-Domain Conditions for Strictly Positive Real Functions", *IEEE Trans. Automat. Contr.*, vol. 32, Jan. 1987, pp. 53-54.
- [7] R. Lozano-Leal and S. M. Joshi, "Strictly Positive Real Functions Revisited", *IEEE Trans. Automat. Contr.*, vol. 35, November 1990, pp. 1243-1245.
- [8] S. M. Joshi and S. Gupta, "On a Class of Marginally Stable Positive-Real Systems", *IEEE Trans. Automat. Contr.*, vol. 41, No. 1, January 1996, pp. 152-155.
- [9] D. J. Hill, "Dissipative Nonlinear Systems: Basic Properties and Stability Analysis", proc. 31st IEEE Conference on Decision and Control, Tucson, Arizona, December 1992, pp. 3259-3264.
- [10] C. I. Byrnes, A. Isidori, and J. C. Willems, "Passivity, Feedback Equivalence, and the Global Stabilization of Minimum Phase Nonlinear Systems", *IEEE Trans. Automat. Contr.*, vol. 36, No. 11, November 1991, pp. 1228-1240.
- [11] B. D. O. Anderson, "A System Theory Criterion for Positive Real Matrices", *SIAM J. Control*, vol. 5, May 1967, pp. 171-182.

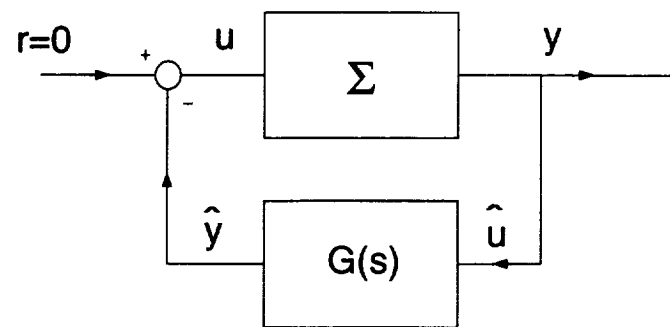

Figure 1: Feedback interconnection

REPORT DOCUMENTATION PAGE

Form Approved
OMB No. 0704-0188

Public reporting burden for this collection of information is estimated to average 1 hour per response, including the time for reviewing instructions, searching existing data sources, gathering and maintaining the data needed, and completing and reviewing the collection of information. Send comments regarding this burden estimate or any other aspect of this collection of information, including suggestions for reducing this burden, to Washington Headquarters Services, Directorate for Information Operations and Reports, 1215 Jefferson Drive Highway, Suite 1204, Arlington, VA 22202-4302, and to the Office of Management and Budget, Paperwork Reduction Project (0704-0188), Washington, DC 20503.

1. AGENCY USE ONLY (Leave blank)		2. REPORT DATE October 1996	3. REPORT TYPE AND DATES COVERED Technical Memorandum	
4. TITLE AND SUBTITLE Robust Stabilization of a Class of Passive Nonlinear Systems			5. FUNDING NUMBERS WU 522-33-11	
6. AUTHOR(S) Suresh M. Joshi Atul G. Kelkar				
7. PERFORMING ORGANIZATION NAME(S) AND ADDRESS(ES) NASA Langley Research Center Hampton, VA 23681-0001			8. PERFORMING ORGANIZATION REPORT NUMBER	
9. SPONSORING / MONITORING AGENCY NAME(S) AND ADDRESS(ES) National Aeronautics and Space Administration Washington, DC 20546-0001			10. SPONSORING / MONITORING AGENCY REPORT NUMBER NASA TM-110287	
11. SUPPLEMENTARY NOTES Joshi: Langley Research Center, Hampton, VA Kelkar: Kansas State University, Manhattan, KS				
12a. DISTRIBUTION / AVAILABILITY STATEMENT Unclassified/Unlimited Subject Category 63			12b. DISTRIBUTION CODE	
13. ABSTRACT (Maximum 200 words) The problem of feedback stabilization is considered for a class of nonlinear, finite dimensional, time invariant passive systems that are affine in control. Using extensions of the Kalman-Yakubovch lemma, it is shown that such systems can be stabilized by a class of finite dimensional, linear, time-invariant controllers which are strictly positive real in the weak or marginal sense. The stability holds regardless of model uncertainties, and is therefore, robust.				
14. SUBJECT TERMS Nonlinear systems control; passive systems; stability theory			15. NUMBER OF PAGES 13	
			16. PRICE CODE A03	
17. SECURITY CLASSIFICATION OF REPORT Unclassified	18. SECURITY CLASSIFICATION OF THIS PAGE Unclassified	19. SECURITY CLASSIFICATION OF ABSTRACT	20. LIMITATION OF ABSTRACT	