

NASA Technical Memorandum 104643

11-31
021541

The Cloud Absorption Radiometer HDF Data User's Guide

**Jason Y. Li, Howard G. Meyer, G. Thomas Arnold, Si-Chee Tsay, and Michael
D. King**

March 1997



NASA Technical Memorandum 104643

The Cloud Absorption Radiometer HDF Data User's Guide

Jason Y. Li
G. Thomas Arnold
Applied Research Corporation
Landover, Maryland

Howard G. Meyer
Science Systems and Applications, Inc.
Lanham, Maryland

Si-Chee Tsay
Michael D. King
Goddard Space Flight Center
Greenbelt, Maryland



National Aeronautics and
Space Administration

Goddard Space Flight Center
Greenbelt, Maryland
1997

This publication is available from the NASA Center for Aerospace Information,
800 Elkridge Landing Road, Linthicum Heights, MD 21090-2934, (301) 621-0390.

TABLE OF CONTENTS

1. Introduction	1
2. CAR Instrument Summary.....	2
3. CAR Raw Data Collection.....	5
4. CAR Radiometric Calibration.....	7
4.1 Integrating Source Calibration	7
4.2 CAR Laboratory Calibration Procedure.....	7
4.3 Application of Calibration Coefficients to in-flight Raw Data.....	8
5. Structure and Contents of CAR HDF Data File	9
5.1 Introduction to HDF Data Format.....	9
5.2 HDF Based netCDF Data Format	11
5.3 CAR HDF Data.....	11
5.4 Reading CAR HDF Data by Examples.....	23
6. Examples of Scientific Results.....	27
6.1 Diffusion Domain Studies.....	27
6.2 Bidirectional Reflection Distribution Function Studies	28
6.3 Multi-spectral Imaging.....	30
7. CAR Contact List.....	32
8. References	33
Appendix A. On-Line Resources.....	34

LIST OF FIGURES

Figure 1. Cutaway drawing of CAR.....	2
Figure 2. CAR instrument is housed in the nose cone of the C-131A aircraft.....	4
Figure 3. An example of digital output of one CAR channel.....	5
Figure 4. CAR relative intensity as a function of scan angles in the diffusion domain (10 July 1987).....	27
Figure 5. To acquire BRDF data, the C-131A flies in a closed circular flight pattern.....	28
Figure 6. Measurements of the BRDF at 0.87 μm over cerrado surface (August 18, 1995).....	29
Figure 7. Measurements of the BRDF at 0.87 μm over a uniform smoke layer (September 6, 1995).	29
Figure 8. Same as in Figure 7 except presented as a 3D surface plot.....	30
Figure 9. CAR 0.86 μm Earth view image, flight 1698, September 4, 1995, SCAR-B experiment.	31

LIST OF TABLES

Table 1. Spectral Characteristics of CAR Channels.....	3
Table 2. Instrumental Specifications of CAR.....	4
Table 3. Matching CAR Data Channels With Spectral Channels.....	6
Table 4. Supported Platforms for HDF Version 4.0.....	10
Table 5. Cloud Absorption Radiometer Data (in alphabetical order).....	12
Table 6. Navigational and Cloud Microphysics Data (in alphabetical order).....	13

1. Introduction

The Cloud Absorption Radiometer (CAR) is a multiwavelength scanning radiometer that measures the angular distribution of scattered radiation. It was developed at NASA Goddard Space Flight Center by Dr. Michael D. King. Originally designed to determine the single scattering albedo of clouds at selected wavelengths in the visible and near-infrared, the CAR has been applied to scientific problems that have evolved dramatically over the years. Nowadays the CAR can also be used to measure bi-directional reflectance for various surface types or simply as an imaging system. Since 1987, it has flown in the nose cone of the Convair C-131A aircraft operated by the University of Washington, Department of Atmospheric Sciences, in concert with an array of cloud microphysics, aerosol, atmospheric chemistry and general meteorological instruments. CAR has been deployed on a regular basis on experiment campaigns around the world. These have included deployments to the Azores, Brazil, Kuwait, continental U.S. and Alaska.

In support of CAR related research, a CAR data processing system was designed and implemented by the Cloud Retrieval Group at NASA Goddard Space Flight Center in early 1995. The purpose of the processing system is to ingest CAR raw data and engineering and navigation data, and to produce calibrated radiances in a portable Hierarchical Data Format (HDF). To complement CAR radiometric data, a set of carefully selected in situ cloud microphysics measurements is included in the CAR HDF data set, the end product being a self-contained and information-rich scientific data set.

The purpose of this document is to describe the CAR instrument, the methods used in the CAR HDF data processing, the structure and format of the CAR HDF data files, and the methods for accessing the data. Examples of CAR applications and their results are also presented. Consult the CAR web page at: <http://climate.gsfc.nasa.gov/~jyli/CAR.html> for the most up-to-date information.

Questions about CAR HDF data should be directed to:

Jason Y. Li, CAR HDF Data Processing
Code 913
NASA Goddard Space Flight Center
Greenbelt, MD 20771
Tel : (301) 286-1029
Fax: (301) 286-1759
Email: jyli@climate.gsfc.nasa.gov

Questions related to the Cloud Microphysics data should be addressed to:

Professor Peter V. Hobbs
Department of Atmospheric Sciences, Box 351640
University of Washington
Seattle, WA 98195-1640
Phone: (206) 543-6027; Email: phobbs@atmos.washington.edu

2. CAR Instrument Summary

The Cloud Absorption Radiometer is capable of measuring the angular distribution of scattered radiation in thirteen spectral bands. Figure 1 shows the overall design of the instrument with many of the mechanical, optical, and electronic components identified. The scan mirror, rotating at 100 rpm, directs the light into a Dall-Kirkham telescope, where the beam is split into eight paths. Seven light beams pass through beam splitters, dichroics, and lenses to individual detectors ($0.30\ \mu\text{m}$ - $1.27\ \mu\text{m}$), and finally get registered by seven data channels. They are sampled simultaneously and continuously. The eighth beam, on the other hand, passes through a spinning filter wheel to a Stirling cycle cooler. Signals registered by the eighth data channel are selected from among six spectral channels ($1.55\ \mu\text{m}$ - $2.30\ \mu\text{m}$) on the filter wheel. The filter wheel can either cycle through all six spectral bands at a prescribed interval (usually changing filter every fourth scan line), or lock onto any one of the six spectral bands and sample it continuously.

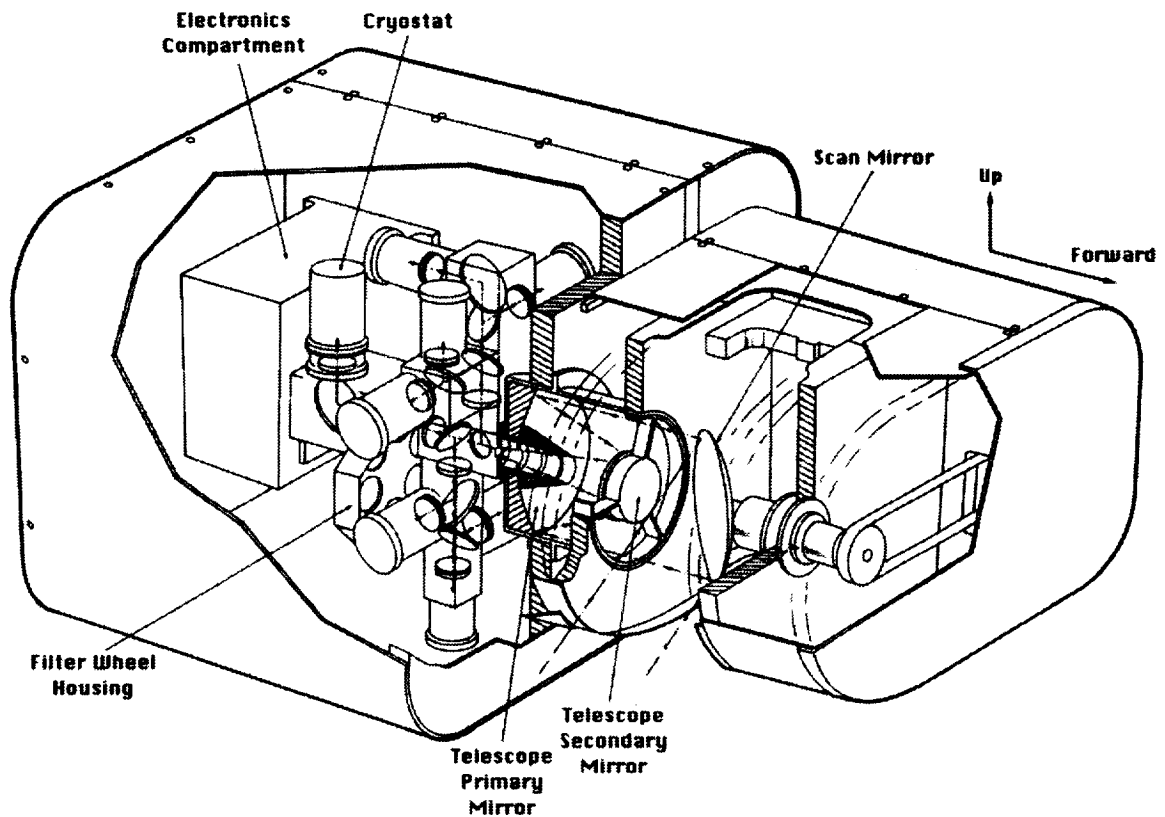

Figure 1. Cutaway drawing of CAR. The dimension of the instrument housing is $72\ \text{cm} \times 41\ \text{cm} \times 39\ \text{cm}$.

Depending on the scientific objectives of an upcoming field experiment, thirteen spectral bands can be configured into two modes in the laboratory. As shown in Table 1, channel 1 is interchangeable between a 0.47 μm band and a 0.5 μm band; and channel 2 is interchangeable between a 0.3 μm UV-B band and a 0.75 μm band.

During a field campaign, the CAR instrument is housed in the nose cone of the University of Washington C-131A research aircraft (Figure 2). The CAR scan mirror scans 360° in a plane perpendicular to the direction of flight. In the normal mode of operation and assuming zero aircraft roll and pitch angle, the CAR views 190° of earth-atmosphere scene around the starboard horizon: from 5° before zenith, through the starboard horizon, and then through 5° past nadir. This configuration permits observation of both zenith and nadir directions with as much as a 5° aircraft roll. In the imaging mode, the CAR and C-131A nose cone assembly are rotated 90° prior to a flight, so that the nose cone opening points downward. Again assuming zero aircraft roll and pitch angle, the CAR viewing area is now 190° around the nadir: from 5° above the starboard horizon, through the nadir and through 5° above the port side horizon. Table 2 summarizes the characteristics of the CAR sensor, platform and scanning system.

Table 1. Spectral Characteristics of CAR Channels

Mode A Spectral Channels	Mode B Spectral Channels	Central Wavelength (μm)	Bandwidth (μm)	Transmittance (%)
	3	0.3071	0.0378	28.7
	1	0.4715	0.0210	78.2
1		0.5066	0.0190	38.9
2	2	0.6752	0.0200	65.5
3		0.7540	0.0090	83.0
4	4	0.8685	0.0215	51.2
5	5	1.0375	0.0200	56.0
6	7	1.2190	0.0205	73.5
7	6	1.2710	0.0200	84.0
8	8	1.5515	0.0318	65.0
9	9	1.6430	0.0405	62.5
10	10	1.7250	0.0375	57.0
11	11	2.0990	0.0385	71.5
12	12	2.2070	0.0395	60.0
13	13	2.3025	0.0430	45.6

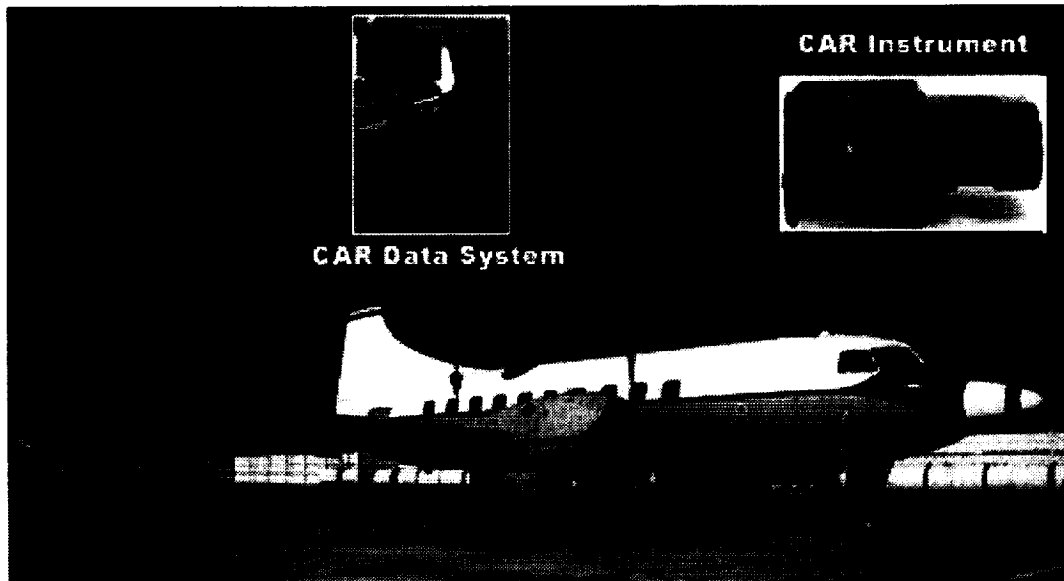

Figure 2. CAR instrument is housed in the nose cone of the C-131A aircraft. In this photo, CAR's aluminum sliding door is in the closed position, protecting the scan mirror and optics assembly from dust and other foreign objects for takeoff and landing.

Table 2. Instrumental Specifications of CAR

Platform	Convair-131A, University of Washington
True air speed	~ 80 meters/second
Total field of view	190°
Instantaneous field of view	1°
Scan rate	100 scans per minute (1.67 Hz)
Pixels per scan line	395 (nominal)
Spectral bands	13
Spectral range	0.3 - 2.3 μm
Data channels (Registered channels)	8
Bits per channel	10
Sampling rate	1250 \times 8 channels = 10000 bytes/second
Data rate	11683 bytes/second

3. CAR Raw Data Collection

At the beginning of each mirror scan cycle, the CAR data acquisition system first records a ten-byte-long header. It contains information such as flight number, current time, roll angle, scan line counter, etc. Following the header is the data stream from eight data channels. Figure 3 shows a sample digital output of one complete scan cycle from one of the CAR channels. Two sync pulses denote the start and end of an active scan segment. These pulses are distinguished by their differing time durations. Assuming zero aircraft roll and pitch angle, the CAR scan mirror should be looking at 5° before zenith direction at the first pulse and 5° past nadir at the second pulse. Also multiplexed into each channel on each scan cycle are the set of reference voltage, as well as the measurements from the four thermistors. The reference voltages range from 0.00 to 8.00 V in steps of 1.00 V and give the appearance of a staircase. This voltage staircase permits the conversion of digital counts to voltage, while the conversion from voltage to radiances is accomplished through the calibration procedure.

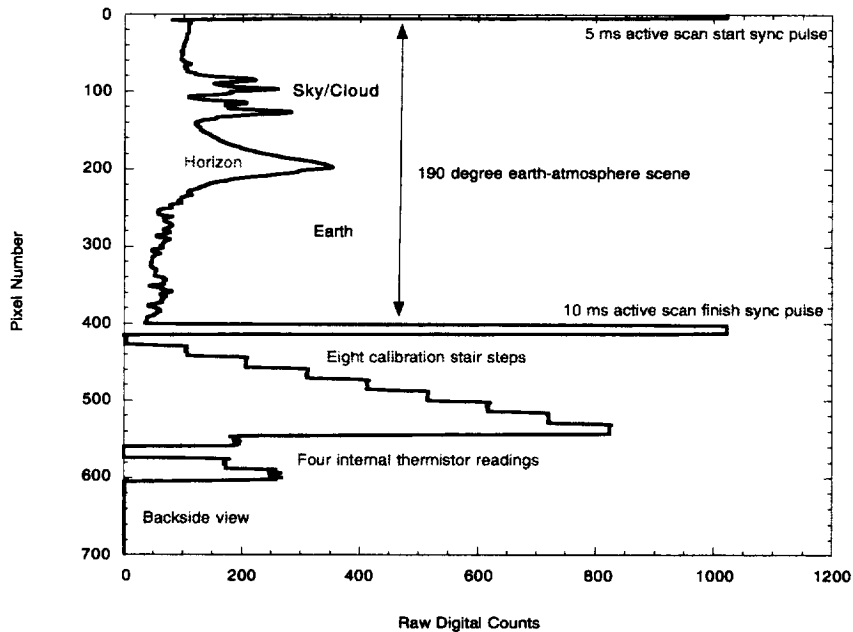

Figure 3. An example of digital output of one CAR channel. The limb brightening phenomenon is a prominent feature in the CAR active scan data, corresponding to the peak as you are seeing here.

Even though there are thirteen spectral channels available, the CAR instrument can only output eight spectral channels of information at one time. The first seven spectral channels feed the data stream continuously. Data channel 8 collects data from one of the filter wheel

channels (spectral channel number 8 - 13) that is being locked on by the filter wheel at the time. Table 3 explains how this works. Let's select arbitrarily eight consecutive scan lines and rotate the filter wheel at every other scan line. The channel numbers shown in Table 3 are data channel numbers. The relationship between the first seven spectral channels and the data channels is obvious. The matching of filter wheel and data channel 8 is entirely dependent on the position of the filter wheel. The filter wheel can cycle through all six spectral channels at a prescribed rate. In Table 3, only four complete cycles are shown. When changing the filter wheel, there is no useful data to be collected by data channel 8, which is filled with missing values. The filter wheel can be locked, that is the prescribed filter wheel rotation rate is zero, then like the other seven data channels, the data channel 8 collects data continuously at a given near-infrared wavelength. The dwell time in the filter wheel can be adjusted from 1 - 10 scans per filter wheel channel (automatic mode) or can be locked into a fixed channel position (manual mode).

Table 3. Matching CAR Data Channels With Spectral Channels

CAR spectral channel	Scan Line 1	Scan Line 2	Scan Line 3	Scan Line 4	Scan Line 5	Scan Line 6	Scan Line 7	Scan Line 8
1	1	1	1	1	1	1	1	1	
2	2	2	2	2	2	2	2	2	
3	3	3	3	3	3	3	3	3	
4	4	4	4	4	4	4	4	4	
5	5	5	5	5	5	5	5	5	
6	6	6	6	6	6	6	6	6	
7	7	7	7	7	7	7	7	7	
8	8	×	–	–	–	–	–	–	
9	–	–	8	×	–	–	–	–	
10	–	–	–	–	8	×	–	–	
11	–	–	–	–	–	–	8	×	
12	–	–	–	–	–	–	–	–	
13	–	–	–	–	–	–	–	–	

- × changing filter
- – no data

4. CAR Radiometric Calibration

Radiometric calibration of the CAR is conducted in the laboratory at Goddard Space Flight Center (GSFC) both before and after use of the CAR in a field deployment. This chapter describes how the calibration is determined and how it is applied to the raw data to convert the raw data values to radiance. The chapter is divided into three sections. The first section discusses the calibration of the standard integrating sources viewed by the CAR during calibration, the second section describes the laboratory procedure used to view the integrating sources and derive the calibration coefficients to convert the CAR output signal to radiance, and, the third section describes how to apply the calibration coefficients to in-flight raw CAR data.

4.1 Integrating Source Calibration

Two integrating sources typically have been used for CAR calibrations: the GSFC six-foot (183 cm) integrating sphere and the four-foot integrating hemisphere. Both sources are internally coated with BaSO₄ paint and internally illuminated by 12 quartz-halogen lamps. Each source is calibrated by Goddard personnel, using a monochromator and reference lamp. The monochromator consists of silicon, germanium, and lead sulfide detectors, each of which detects narrow band radiation dispersed from their individual gratings. The monochromator makes a relative measurement of input radiance (every 10 nm) with respect to a reference lamp in the wavelength range from 0.4 to 2.5 μm . The monochromator reference lamp is traceable to a standard lamp approved by the National Institute of Standards and Technology (NIST) and is periodically checked against other instruments during round robin intercomparisons.

The integrating source calibration by the method just described is conducted with the sources at maximum intensity (12 lamps on). Tests, however, also are conducted to determine source radiance at fewer than 12 lamps. Lamps are turned off, one at a time, and source radiance data in the wavelength range from 0.4 to 0.95 μm is recorded. These radiance values for each lamp level are then divided by the radiance at 12 lamps to give the relative intensity for each lamp level. Since the relative intensity values vary less than one percent over the wavelength range, relative intensity is considered independent of wavelength. Thus, for each lamp level, the same relative radiance is applied regardless, of wavelength.

4.2 CAR Laboratory Calibration Procedure

The CAR is calibrated in the laboratory at GSFC both before and after its participation in a field experiment. The CAR is set up to view the radiometric source through an opening in the side of the source (a 10-inch-diameter opening for the hemisphere and a 12-inch opening for the sphere). Beginning with all 12 source lamps on, the output voltage level

for each of the seven gain settings for each of the 13 CAR channels is sampled in sequence (controlled by a custom-designed “auto-calibrator” box). The sampling consists of averaging a selected portion of the output voltage level of each scan (when viewing the source) for about 30 scans. Each sample is digitized and written to a computer disk file. This procedure is repeated for each lamp level. Thus, for each gain setting of each CAR channel, calibration coefficients (slope and intercept) are computed from linear regression of the CAR-measured voltage at each lamp level, and the corresponding radiance values (source radiance at the central wavelength of each channel). Analysis of the calibration coefficients shows that the slope values for each channel are independent of gain setting (though the offset usually varies slightly with gain setting).

4.3 Application of Calibration Coefficients to In-flight Raw Data

Conversion of in-flight recorded raw CAR data to radiance is a two-step process. CAR data are measured in voltage but are digitized by the data system and recorded as 10-bit count values. Thus, the first step is to convert the count values to voltage. This counts-to-volts conversion is derived from a linear regression of the measured CAR count values (recorded during the backscan of each scan) for eight specified voltage levels (cf. Figure 3). The slope and intercept of this regression are used to convert counts to volts as follows:

$$V = C * M_c + V_0, \quad (4.1)$$

where V is the CAR voltage, C is the CAR counts value to be converted to volts, M_c is the slope of the counts to voltage conversion and V_0 is the offset of the counts to volts conversion

The second step is the conversion of the voltage value to radiance. This also is a linear relationship where the slope (radiance per volt) and offset were determined through the analysis described in the previous section. The volts-to-radiance conversion is given by

$$I = (V/G) * M_v + I_0, \quad (4.2)$$

where I is the calibrated radiance value, V is the CAR voltage derived from equation 4.1, G is the gain (CAR has 7 gain values: 0.125, 0.25, 0.5, 1.0, 2.0, 4.0, 8.0), M_v is the slope of the volts-to-radiance conversion (gain = 1.0), and I_0 is the radiance offset (gain = 1.0).

5. Structure and Contents of CAR HDF Data File

5.1 Introduction to HDF Data Format

HDF stands for Hierarchical Data Format and was created at the National Center for Supercomputing Applications (NCSA). HDF is a multiobject file format for the transfer of graphical and numerical data between machines. It supports six different data models:

- 8-bit raster images
- 24-bit raster images
- color palettes
- text annotation
- binary table (Vdata model)
- scientific data sets model (SDS model)

Each data model defines a specific type of data and provides a convenient interface for reading, writing, and organizing a unique set of data elements. In a sense, the word HDF carries dual meanings: it is an **interface** to a library of data access programs that store and retrieve HDF **file format** data.

CAR data sets are stored as HDF SDS-based netCDF data objects

There are numerous advantages of storing data in general purpose HDF format over any “purpose specific” format. Just name a few:

- HDF is a self-describing format, allowing an application to interpret the contents of a file without any outside information. From a programmer’s point of view, parameters in an HDF file are retrieved by their names, not by their physical locations in the file. Unlike working with purpose specific data formats, you do not need to know the structural details of an HDF file. In addition to meaningful parameter names, the self-describing capability is further enhanced by adding the parameter attributes or name tags, such as parameter physical units, scale factors and missing values.
- HDF is a portable file format, sometimes described as a network transparent file format. Usually different computer architectures have different ways of representing integers and floating-point numbers. In order to read a binary file on a different computer platform, for example, you need to resolve issues like byte ordering and the position of the most and least significant bytes. With HDF, these things are all taken care of by the HDF library. HDF files can be shared across platforms. An HDF file created on one computer, say a Cray supercomputer, can be read on another system, say an IBM PC, without modification. HDF library does all the hard work for you

behind the scene. A full list of HDF (version 4.0 release 2) supported platforms are presented in Table 4.

- HDF is available in the public domain and is fully supported by NCSA. You can obtain an HDF software package, a user manual, and a reference manual by anonymous ftp on Internet at `ftp.ncsa.uiuc.edu` (141.142.21.14). There is also a galaxy of information on the NCSA's HDF Information Server (world wide web site) at `http://hdf.ncsa.uiuc.edu/`. To join in the discussions of various common data file formats, Usenet newsgroup `sci.data.formats` may be a good place to visit. And of course you can send any comments or suggestions to HDF user support by E-mail at `hdfhelp@ncsa.uiuc.edu`.

Table 4. Supported Platforms for HDF Version 4.0

Platform/Operating System	Basic HDF Library libdf.a	HDF/netCDF Library libmfhdf.a
Sun4/SunOS 4.1.3	Yes	Yes
Sun4/Solaris 2.4 - 2.5	Yes	Yes
SGI-Indy/IRIX5.3	Yes	Yes
SGI/IRIX6.1_n32bit	Yes	Yes
SGI/IRIX6.1_64bit	Yes	Yes
HP9000/HPUX9.03	Yes	Yes
Cray Y-MP/UNICOS 803.2	Yes	Yes
Cray C90/UNICOS 803.2	Yes	Yes
Thinking Machine CM5	Yes	Yes
IBM RS6000/AIX v4.1	Yes	Yes
IBM SP2	Yes	Yes
DEC Alpha/Digital Unix v3.2	Yes	Yes
DEC Alpha/Open VMS AXP v6.2	Yes	Yes
Fujitsu UXP/UXPM	Yes	Yes
IBM PC/Solarisx86	Yes	Yes
IBM PC/Linux v1.2.4	Yes	Yes
IBM PC/Linux elf 1.2.13	Yes	Yes
IBM PC/FreeBSD 2.0	Yes	Yes
Windows NT/95	Yes	Yes
PowerPC/Mac OS 7.5	Yes	Yes
VAX/VMS	No	No

5.2 HDF-Based netCDF Data Format

Like HDF, netCDF (network Common Data Form) is another very popular interface to a library of data access programs that store and retrieve data. The netCDF file format is also self-describing and network-transparent. It was developed by the Unidata Program Center, University Corporation for Atmospheric Research (UCAR) in Boulder, Colorado. The original intent was to provide U.S. universities a common data access method for the various Unidata applications. While HDF has six sets of interfaces supporting six data models, netCDF, on the other hand, has only one set of interface for supporting one data model. The counterpart of netCDF in HDF is the multifile Scientific Data Sets (SDS).

Then what is the HDF-based netCDF data format? As alluded to in the preceding section, CAR data are stored as HDF SDS-based or encoded netCDF objects. To understand the connection between HDF SDS and netCDF objects, we have to look back to the history of their developments. HDF and netCDF were created independently by two research organizations. Despite their similarities, in the early days the HDF SDS interface could not read a netCDF object or vice versa. However, this predicament has changed recently, thanks to the cooperative spirit between the HDF development group at NCSA and the netCDF group at UCAR. From HDF version 3.3, HDF SDS interface supports complete netCDF interface as defined by Unidata netCDF Release 2.3.2, and the netCDF data format is interchangeable with the HDF SDS data model in so far as it is possible to use the netCDF calling interface to place an SDS into an HDF file. Nowadays, using either interface (HDF SDS or netCDF), you are able to read HDF SDS based netCDF files (such as our Cloud Absorption Radiometer HDF files), pre-HDF 3.3 HDF files and XDR*-based netCDF files. The HDF/netCDF library provided by NCSA identifies what type of file is being accessed and handles it appropriately. It is completely transparent to the programmers. In section 5.4, we will show you how to retrieve HDF SDS-based netCDF objects using either interfaces in FORTRAN, C, or IDL programming languages.

If you choose the netCDF interface to read HDF-based netCDF files, the netCDF User's Guide is indispensable. A postscript version of the user's guide can be obtained by anonymous ftp at <ftp.unidata.ucar.edu>. It is also available on the Internet as an HTML document at <http://unidata.ucar.edu/packages/netcdf/index.html>.

5.3 CAR HDF Data

The contents of a CAR HDF data set are primarily made up of three components: calibrated CAR radiance data, aircraft navigational data, and a suite of CAR research relevant to cloud microphysics data. The latter two data sets are maintained and distributed by the Cloud and

* XDR stands for eXternal Data Representation. XDR, developed by Sun Microsystems Inc, is a non-proprietary standard for describing and encoding data. It supports encoding arbitrary C data structures into machine-independent sequences of bits. The encoding used for floating-point numbers is the IEEE standard for normalized floating-point numbers.

Aerosol Research Group, University of Washington. Data dimensions, physical units, and missing values of every variable in the CAR HDF data set are listed in Table 5 and 6.

Table 5. Cloud Absorption Radiometer Data (in alphabetical order)

CAR Parameters	Dimension (FORTRAN Style)	Units	Missing Value
AmplifierGain	time	-	-
BasePlateTemperature	time	Celsius	-
BeforeNadirIndex	time	-	-
CalibratedData	(410, 8, time)	watts/m ² /steradian/μm	-
CalibrationIntercept	13	watts/m ² /steradian/μm	-
CalibrationSlope	13	watts/m ² /steradian/μm/volt	-
CarRoll	time	degree	-
CentralWavelength	13	μm	-
Coordinated Universal Time	time	HHMMSS	-
CountsVoltageIntercept	time	volts	-
CountsVoltageSlope	time	Volts/count	-
DoorOpenStatus	time	-	-
FilterWheelChannel	time	-	-32768
FilterWheelPosition	time	-	-32768
LongwaveDataGood	time	-	-32768
ManualGainControl	time	-	-
NumberOfScanPixels	410	-	-
Optics1Temperature	time	Celsius	-
Optics2Temperature	time	Celsius	-
PastZenithIndex	time	-	-
PrimaryMirrorTemperature	time	Celsius	-
ScanAngle1	time	degree	-
ScanLineCounter	time	-	-
ScanMirrorCondensationFlag	time	-	-
SolarAzimuthAngle	time	degree	-99999.0
SolarSpectralIrradiance	13	watts/meter ² /micron	-
SolarZenithAngle	time	degree	-99999.0

Table 6. Navigational and Cloud Microphysics Data (in alphabetical order)

Parameters	Dimension (Fortran Style)	Units	Missing Value
AircraftAltitude	time	meters	-99999.0
AircraftHeading	time	degree	-99999.0
AircraftLatitude	time	degree_north	-99999.0
AircraftLongitude	time	degree_east	-99999.0
AircraftPitch	time	degree	-99999.0
AircraftRoll	time	degree	-99999.0
CCNCounter#3	time	number/cm ³	-99999.0
DewPointTemperatureChilledMirror	time	degree_Celsius	-99999.0
DewPointTemperatureOPHIR	time	degree_Celsius	-99999.0
LiquidWaterContentFSSP	time	grams/m ³	-99999.0
LiquidWaterContentGerberProbe	time	grams/m ³	-99999.0
LiquidWaterContentJW0Probe	time	grams/m ³	-99999.0
LiquidWaterContentKingProbe	time	grams/m ³	-99999.0
ParticleEffectiveRadiusFSSP+CloudProbe	time	microns	-99999.0
ParticleEffectiveRadiusPVM	time	microns	-99999.0
ParticleNumberConcentrationFSSP	time	number/cm ³	-99999.0
PressureAltitude	time	kilometers	-99999.0
PyranometerDown	time	watts/meter ²	-99999.0
PyranometerUp	time	watts/meter ²	-99999.0
RadarAltitude	time	meters	-99999.0
StaticPressure	time	mb	-99999.0
StaticTemperature	time	degree_Celsius	-99999.0
StaticTemperatureReverseFlow	time	degree_Celsius	-99999.0
TrueAirSpeed	time	meters/second	-99999.0
WindDirectionGPS	time	degree	-99999.0
WindSpeedGPS	time	meters/second	-99999.0

From a data format point of view, a CAR HDF data file contains four categories of data objects: dimensions, global attributes, variables and variable attributes. One dimension in CAR HDF file is allowed to be *unlimited* size, which means a variable using this dimension can grow to any length limited only by the disk storage space. In our case, the unlimited dimension is the time variable.

Global Attributes

```
:title = "Cloud Absorption Radiometer HDF data" ;
:CreationDate = "16-Nov-95 10:45:42" ;
Date and time that this HDF file was created.
```

:CreatedBy = "Jason Li (jyli@climate.gsfc.nasa.gov)" ;

Person who created this CAR HDF file.

:SoftwareVersion = "Version 3.2" ;

HDF data processing software version number.

:Credits = "J. Y. Li, H. G. Meyer, G. T. Arnold, S. C. Tsay and M. D. King";

:ExperimentName = "SCAR-B 1995" ;

Name of CAR mission.

:FlightDate = " 4 Sep 1995";

Beginning date of CAR flight.

:CarViewingMode = "Downward" ;

Specify how the CAR is being mounted in the nose cone of the host aircraft. The normal viewing mode is to scan around the starboard horizon.

:CarOperatorComment = "CAR used as an imager; On transit from Cuiaba to Vilhena, coordinated flight with ER-2 NW of Cuiaba; Fairly uniform aerosol on climbout; Clouds dissipated W/NW of Cuiaba. Also see SCAR-B CAR Flight Log by Jason Li, NASA Goddard Space Flight Center." ;

Character string records CAR operator's flight summary.

:LocalTimeOffset = -4s ;

Difference between local time and UTC, expressed in hours. Positive is for the regions east of Greenwich meridian and negative for the west. Add LocalTimeOffset to the UTC time, you get the local time.

:JulianDay = 247s ;

Number of days since the first day of the year, not the Julian date concept defined by Astronomical community.

:FlightNumber = 1698s ;

C131A flight number assigned by University of Washington.

:data_set = "Cloud Absorption Radiometer HDF Data" ;

:data_product = "Flight Track" ;

:sensor = "Cloud Absorption Radiometer" ;

:platform = "Convair C-131A" ;

Host aircraft name.

:platform_type = "Research Aircraft" ;

:PrimaryNavigationSystem = "GPS Trimble TNL-3000" ;

Aircraft navigation system. Prior to the Spring of 1985, only the VOR/DME and header information were recorded. However, starting in May 1985 (or so), Chief Flight Engineer Jack Russell from University of Washington managed to decode the RS-232 port information coming from the Omega/VLF receiver (a Litton LTN-3000), which provided latitude and long info for the first time.

University of Washington research team bought a GPS receiver Trimble TNL 3000 (civilian grade GPS) in March, 1991 just prior to the Kuwait fires project and has been in service ever since.

:science_project = "NASA/GSFC Cloud Retrieval Group" ;

:parameter_general="RADIANCE AND CLOUD MICROPHYSICS DATA" ;

:parameter_specific = "CAR Angular Distributed Radiances and 1-second Averaged C131 Cloud Microphysics Data" ;

:geog_flag = "c" ;

Geographic flag (DACC required metadata) c=constrained.

:day_night_flag = "d" ;

Day/Night flag (DACC required metadata). In CAR HDF data sets, this flag should always be "d" because CAR is operated in sunlit environment.

:begin_date = "19950904 184958" ;

Date and time of the first good data being collected on this flight. (DACC required metadata).

:end_date = "19950904 203257" ;

Date and time of the last good data being collected on this flight (DACC required metadata).

:lat_min = -15.713f ;

Southernmost location the aircraft has ever reached during the entire flight (DACC required metadata).

:lat_max = -12.9377f ;

Northernmost location the aircraft has ever reached during the entire flight (DACC required metadata).

:lon_min = -59.889702f ;

Westernmost location the aircraft has ever reached during the entire flight (DACC required metadata).

:lon_max = -56.1628f ;

Easternmost location the aircraft has ever reached during the entire flight (DACC required metadata).

Dimensions

time = UNLIMITED ; // (10335 currently)

The unlimited dimension in the CAR HDF data set is the time dimension. It can also be understood as number of scan lines in the CAR HDF data file.

NumberOfPixels = 410 ;

Maximum number of scan pixels per scan line.

NumberOfChannels = 13 ;

Number of CAR spectral channels.

NumberOfDataChannels = 8 ;

Number of CAR data channels. Seven of them are sampled simultaneously and continuously, and the remaining data channel is fed from one of the six spectral channels on the CAR filter wheel channel.

Variables and Their Attributes

long CoordinatedUniversalTime(time) ;

CAR time code in UTC (HHMMSS format). CAR instrument does not have its own time code generator. The C131 master clock feeds time information to CAR data stream on a 1-second carrier wave. Therefore the CAR time code resolution is truncated to a second. Recall the CAR sampling rate is 1.67 Hz, the scan mirror may have completed two scans, while the clock reading remains unchanged.

long ScanLineCounter(time) ;

Number of scan mirror revolutions. The ScanLineCounter starts at 1 when the CAR instrument is powered on. However, a CAR operator often does not activate the data recording system until the CAR filterwheel channels are cooled sufficiently for better signal-to-noise ratio. The initial value of ScanLineCounter in an HDF file is usually on the order of hundreds.

float CentralWavelength(NumberOfChannels) ; CentralWavelength:units = "microns" ;

CAR channel central wavelength in microns.

float SolarSpectralIrradiance(NumberOfChannels) ;

SolarSpectralIrradiance:units = "watts/meter2/micron" ;

Solar spectral irradiance at top of the atmosphere for each CAR channel. They are computed using LOWTRAN code.

short FilterWheelPosition(time) ;

FilterWheelPosition:missing_value = -32768s ;

It can take an integer value between 1 and 6, corresponding to 6 filters on the filterwheel. A missing value of -32768 indicates the filterwheel is in the middle of changing filter.

short LongwaveDataGoodFlag(time) ;

Engineering data; 0 for good, otherwise 1.

short ScanMirrorCondensationFlag(time) ;

Scan mirror condensation indicator; 0 for no condensation, otherwise 1.

short ManualGainControl(time) ;

Manual gain control setting. Presently, there are 7 different gain settings (from 0 to 6) available, corresponding to amplification gain range from one-eighth to eight times.

short DoorOpenStatus(time) ;

Engineering data; 0 for door close and 1 for door open status. In CAR HDF data sets, CAR door should always be open.

short FilterWheelChannel(time) ;

FilterWheelChannel:missing_value = -32768s ;

It indicates which filterwheel channel is being used at the moment. Filterwheel channel number is between 8 and 13.

float AircraftLatitude(time) ;

AircraftLatitude:units = "degree_north" ;

AircraftLatitude:missing_value = -99999.f ;

Aircraft subpoint latitude. Positive values are for locations in the northern hemisphere; negative values, for locations in the southern hemisphere. They are derived from whichever primary navigational system is being used at the time of the flight, usually GPS system.

float AircraftLongitude(time) ;

AircraftLongitude:units = "degree_east" ;

AircraftLongitude:missing_value = -99999.f

Aircraft subpoint longitude. Positive values are for locations east of Greenwich meridian; negative values for locations west of Greenwich meridian. They are derived from whichever the primary navigational system is being used at the time of the flight, usually GPS system.

float AircraftHeading(time) ;

AircraftHeading:units = "degree" ;

AircraftHeading:missing_value = -99999.f ;

True heading derived from OMEGA navigation system. The system converts from magnetic to true heading from a King KCS-55A gyrocompass, range 0 °- 360 ° (± 0.5°).

float AircraftPitch(time) ;

AircraftPitch:units = "degree" ;

AircraftPitch:missing_value = -99999.f ;

Aircraft pitch. Nose up is positive. Considered to be very noisy in data quality. The measured voltage is converted to angle by interpolating between points from calibration measurements made when the device was first installed.

float TrueAirSpeed(time) ;

TrueAirSpeed:units = "meters/second" ;

TrueAirSpeed:missing_value = -99999.f ;

True air speed is either computed from static pressure and ram-pressure or measured by Rosemount (MODEL 831BA) variable capacitance with a dynamical range of 0 - 250 m/s (error < 0.2%).

float AircraftRoll(time) ;

AircraftRoll:units = "degree" ;

AircraftRoll:missing_value = -99999.f ;

Aircraft roll. Right wing up is positive. Considered to be very noisy. The measured voltage is converted to angle by interpolating between points from calibration measurements made when the device was first installed.

float CarRoll(time) ;

CarRoll:units = "degree" ;

Roll angle measured by CRG's own gyro. Right wing *down* is positive.

float PressureAltitude(time) ;

PressureAltitude:units = "kilometers" ;

PressureAltitude:missing_value = -99999.f ;

Pressure altitude is either computed from static pressure, scale height, and surface pressure, or measured by Rosemount (MODEL 830BA) variable capacitance with a range 150 - 1100 mb (error < 0.2%).

float RadarAltitude(time) ;

RadarAltitude:units = "meters" ;

RadarAltitude:missing_value = -99999.f ;

Distance above Earth, measured by timing the round trip travel time for a radar pulse. Radar altimeter model is AN/APN22, ranging 0 - 6 km (error < 5%).

float AircraftAltitude(time) ;

AircraftAltitude:units = "meters" ;

AircraftAltitude:missing_value = -99999.f ;

Aircraft altitude above mean sea level, derived from GPS navigation system.

float StaticPressure(time) ;

StaticPressure:units = "mb" ;

StaticPressure:missing_value = -99999.f ;

Static pressure in millibars measured by Rosemount model 830BA pressure transducer.

float StaticTemperature(time) ;

StaticTemperature:units = "degree_Celsius" ;

StaticTemperature:missing_value = -99999.f ;

Static temperature is measured directly by the deiced Rosemount probe.

float StaticTemperatureReverseFlow(time) ;

StaticTemperatureReverseFlow:units = "degree_Celsius" ;

StaticTemperatureReverseFlow:missing_value = -99999.f ;

Static temperature measured by probe developed in house at University of Washington. It uses special housing to reverse the air flow in order to reduce the dynamic heating and evaporative cooling by cloud liquid water.

float WindSpeedGPS(time) ;

WindSpeedGPS:units = "meters/second" ;

WindSpeedGPS:missing_value = -99999.f ;

Wind speed computed from the GPS ground track, GPS ground speed, OMEGA heading, and aircraft true air speed.

float WindDirectionGPS(time) ;

WindDirectionGPS:units = "degree" ;

WindDirectionGPS:missing_value = -99999.f ;

Wind speed computed from the GPS ground track, GPS ground speed, OMEGA heading and aircraft true air speed. Direction is where the wind is coming from.

float CCNCounter#3(time) ;

CCNCounter#3:units = "number/cm3" ;

CCNCounter#3:missing_value = -99999.f ;

Cloud condensation nuclei counter #3. General Electric TSI Model 3070, connected to TSI Model 3040 diffusion battery. The computer counts the nuclei. Only the counts from the zero port are returned. CNC #3 sometimes is removed for use by another instrument (the DMPS).

float ParticleNumberConcentrationFSSP(time) ;

ParticleNumberConcentrationFSSP:units = "number/cm3" ;

ParticleNumberConcentrationFSSP:missing_value = -99999.f ;

Particle number concentration based on Forward Scattering Spectrometer Probe.

float LiquidWaterContentJW0Probe(time) ;

LiquidWaterContentJW0Probe:units = "grams/meter3" ;

LiquidWaterContentJW0Probe:missing_value = -99999.f ;

Liquid water content—zero drift adjusted (Johnson-Williams).

float LiquidWaterContentGerberProbe(time) ;
 LiquidWaterContentGerberProbe:units = "grams/meter3" ;
 LiquidWaterContentGerberProbe:missing_value = -99999.f ;
Liquid water content - measured by Gerber probe.

float LiquidWaterContentKingProbe(time) ;
 LiquidWaterContentKingProbe:units = "grams/meter3" ;
 LiquidWaterContentKingProbe:missing_value = -99999.f ;
Liquid water content - measured by King probe.

float LiquidWaterContentFSSP(time) ;
 LiquidWaterContentFSSP:units = "grams/meter3" ;
 LiquidWaterContentFSSP:missing_value = -99999.f ;
Liquid water content - measured by Forward Scattering Spectrometer Probe.

float ParticleEffectiveRadiusFSSP+CloudProbe(time) ;
 ParticleEffectiveRadiusFSSP+CloudProbe:units = "microns" ;
 ParticleEffectiveRadiusFSSP+CloudProbe:missing_value = -99999.f ;
Particle effective radius computed from measured size spectra of FSSP and cloud probe.

float ParticleEffectiveRadiusPVM(time) ;
 ParticleEffectiveRadiusPVM:units = "microns" ;
 ParticleEffectiveRadiusPVM:missing_value = -99999.f ;
Particle effective radius measured by Gerber PVM probe.

float DewPointTemperatureOPHIR(time) ;
 DewPointTemperatureOPHIR:units = "degree_Celsius" ;
 DewPointTemperatureOPHIR:missing_value = -99999.f ;
Dew point temperature determined by Ophir Corp instrument.

float DewPointTemperatureChilledMirror(time) ;
 DewPointTemperatureChilledMirror:units = "degree_Celsius" ;
 DewPointTemperatureChilledMirror:missing_value = -99999.f ;
Cooled mirror dew point temperature measured by Cambridge TH73-244 instrument, with a range of -40° – +40° (error < 1°).

float PyranometerUp(time) ;
 PyranometerUp:units = "watts/meter2" ;
 PyranometerUp:missing_value = -99999.f ;
Upward looking pyranometer; Epply thermopile Model PSP.

float PyranometerDown(time) ;
 PyranometerDown:units = "watts/meter2" ;
 PyranometerDown:missing_value = -99999.f ;
Downward looking pyranometer; Epply thermopile Model PSP.

float SolarZenithAngle(time) ;

SolarZenithAngle:units = "degree" ;

SolarZenithAngle:missing_value = -99999.f ;

Solar zenith angle computed based on Smithsonian Meteorological Tables.

float SolarAzimuthAngle(time) ;

SolarAzimuthAngle:units = "degree" ;

SolarAzimuthAngle:missing_value = -99999.f ;

Solar azimuth angle computed based on Smithsonian Meteorological Tables.

short Optics1Temperature(time) ;

Optics1Temperature:units = "degree_Celsius" ;

Optics1Temperature:scale_factor = 0.0099999998f ;

Instrument temperature of optics assembly B = *Optics1Temperature * scale_factor*.

short Optics2Temperature(time) ;

Optics2Temperature:units = "degree_Celsius" ;

Optics2Temperature:scale_factor = 0.0099999998f ;

Instrument temperature of optics assembly C = *Optics2Temperature * scale_factor*.

short PrimaryMirrorTemperature(time) ;

PrimaryMirrorTemperature:units = "degree_Celsius" ;

PrimaryMirrorTemperature:scale_factor = 0.0099999998f ;

Primary mirror temperature = *PrimaryMirrorTemperature * scale_factor*

short BasePlateTemperature(time) ;

BasePlateTemperature:units = "degree_Celsius" ;

BasePlateTemperature:scale_factor = 0.0099999998f ;

Baseplate temperature = *BasePlateTemperature * scale_factor*

float CountsVoltageSlope(time) ;

CountsVoltageSlope:units = "volts/count" ;

Raw counts-to-voltage conversion slope. It is determined for each scan line and is used in the counts to radiance conversion process.

float CountsVoltageIntercept(time) ;

CountsVoltageIntercept:units = "volts" ;

Raw counts-to-voltage conversion intercept. It is determined for each scan line and is used in the counts to radiance conversion process.

float CalibrationSlope(NumberOfChannels) ;

CalibrationSlope:units = "watts/meter2/steradian/micron/volt" ;

Voltage-to-radiance conversion slope. It is obtained from laboratory radiometric calibration procedure and is used in the counts-to-radiance conversion process.

float CalibrationIntercept(NumberOfChannels) ;

CalibrationIntercept:units = "watts/meter2/steradian/micron" ;

Voltage to radiance conversion intercept. It is obtained from laboratory radiometric calibration procedure and is used in the counts-to-radiance conversion process.

short AmplifierGain(time) ;

AmplifierGain:scale_factor = 0.001f ;

Amplification gain factor = *AmplifierGain* * *Scale_factor*. It is used in the counts to radiance conversion process.

short NumberOfScanPixels(time) ;

Number of active scan pixels. It is used in determining the scan angle of each scan pixel.

short PastZenithIndex(time) ;

PastZenithIndex:missing_value = -32768s ;

Pixel number for the first pixel past zenith. So the local zenith is somewhere between this pixel and previous one.

short BeforeNadirIndex(time) ;

BeforeNadirIndex:missing_value = -32768s ;

Pixel number for the last pixel just before nadir. So the local nadir is somewhere between this pixel and the next one.

float ScanAngle1(time) ;

ScanAngle1:units = "degree" ;

Scan angle for the first active scan pixel. It is used in determining the scan angle for each scan pixel. Thus the scan angle for i^{th} pixel (θ_i) in an active scan can be determined by

$$\theta_i = \theta_0 + (i - 1) * 190.0 / (N - 1), \quad (5.1)$$

where:

$i = 1, 2, \dots, N$

$\theta_1 = \text{ScanAngle1}$

$N = \text{NumberOfScanPixels}$

short CalibratedData(time, NumberOfRegisteredChannels, NumberOfPixels)

CalibratedData:scale_factor = 0.19561617f, 0.28452677f, 0.41445029f, 0.090800203f, 0.13710038f, 0.049314979f, 0.034395352f, 0.049673285f ;

CalibratedData:units = "watts/meter2/steradian/micron" ;

CalibratedData:missing_value = -32768s ;

Calibrated radiance values = *CalibratedData* * *scale_factor*

The calibrated radiance values are related to the raw digital counts by the following relationship:

$$\text{radiance} = (1 / \text{Gain}) * [I_{v2r} + S_{v2r} * (C - I_{c2v}) / S_{c2v}], \quad (5.2)$$

where:

C = raw digital counts

Gain = AmplifierGain

S_{v2r} = CalibrationSlope

I_{v2r} = CalibrationIntercept

S_{c2v} = CountsVoltageSlope

I_{c2v} = CountsVoltageIntercept

5.4 Reading CAR HDF Data by Examples

A CAR HDF data set (74 kilobytes) has been created specifically for testing purposes. It contains all the data objects in a full-blown CAR HDF file, and CAR radiances from one complete scan cycle. Sample programs are also available to illustrate how to read data objects from the test data file and express CAR radiances as a function of scan angle. They may be obtained either directly from the CAR home page at or by anonymous FTP (Appendix A).

An HDF-based netCDF object such as those in the CAR HDF file can be read by calling either HDF interface routines or netCDF interface routines. Here is a sample program that uses the netCDF interface:

```
PROGRAM nchdfrad
C=====
c PROGRAMMER: Jason LI
c           Climate and Radiation Branch
c           NASA Goddard Space Flight Center
c           Greenbelt, MD 20771
c
c           Email: jyli@climate.gsfc.nasa.gov
C.....
c
c D E S C R I P T I O N :
c           to extract CAR radiance values from a CAR HDF test data
c           file by calling netCDF routines.
c
c U S A G E:
c           nchdfrad
c
c O U T P U T S:
c           list CAR radiance values as a function of scan angles
c           to screen.
c
c
```

```

c L A N G U A G E :
c          FORTRAN compiled on SGI Indigo running IRIX 6.2
c          I used makefile "f77nchdfrad.mak" to compile the program.
c
c H I S T O R Y :
c
c $Log: nchdfrad.f,v $
c Revision 1.1 1997/02/07 02:39:56 jyli
c Initial revision
c
c=====
c
c          IMPLICIT NONE
c          INCLUDE      '/usr/local/include/netcdf.inc'
c
c          integer      numberPixels, numberDataChannels
c          real          aperture
c
c          parameter (numberPixels = 410, numberDataChannels = 8)
c          parameter (aperture = 190.0)
c
c          character    hdfFilename*12
c          integer      recordNumber
c
c          integer      i, j, k, hdfid, varid, slcid, pixid, angid, iret
c          &            ,      scanLineCounter
c          &            ,      start(3), count(3)
c
c          integer*2    numberScanPixels, missing
c          &            ,      calibratedData(numberPixels, numberDataChannels)
c
c          real         delta, scanAngle1, badData
c          &            ,      scanAngles(numberPixels)
c          &            ,      radiance(numberDataChannels)
c          &            ,      scalefac(numberDataChannels)
c
c          data hdfFilename /'test.hdf'/ ! input HDF filename
c          data recordNumber/1/          ! input record number
c          data badData/-999.0/
c
c set proper HDF error handling characteristics:
c          call ncptopt( NCVERBOS + NCFATAL )
c
c
c... open an existing HDF file with READONLY mode turned on:

```

```

c
    hdfid = ncopn ( hdfFilename, NCNOWRIT, iret )

c
c retrieve named variables (single data value):
c
    slcid = ncvid(hdfid, 'ScanLineCounter', iret)
    call ncvgt1(hdfid, slcid, recordNumber, scanLineCounter, iret)
    write(*,5) scanLineCounter
5    format('Scan_Line_Counter = ', i5)

    pixid = ncvid(hdfid, 'NumberOfScanPixels', iret)
    call ncvgt1(hdfid, pixid, recordNumber, numberScanPixels, iret)

    angid = ncvid(hdfid, 'ScanAngle1', iret)
    call ncvgt1(hdfid, angid, recordNumber, scanAngle1, iret)

c
c retrieve a named variable (slab data) including its attributes:
c
    varid = ncvid(hdfid, 'CalibratedData', iret)

    start(1) = 1
    start(2) = 1
    start(3) = recordNumber

    count(1) = numberPixels
    count(2) = numberDataChannels
    count(3) = 1

    call ncvgt(hdfid, varid, start, count, calibratedData, iret)

    call ncagt(hdfid, varid, 'missing_value', missing, iret)
    call ncagt(hdfid, varid, 'scale_factor', scalefac, iret)

c
c... close HDF file and done:
c
    call ncclos(hdfid, iret)

c
c... compute scan angles and radiances:
c

    write(*,'(/, ' Pixel Angles ', 3x, '|', 23(1H-),

```

```

&          '' Radiances '' ,23(1H-),''|''')
c      scan angle increment:
      delta = aperture / float(numberScanPixels - 1)

      do 10 i = 1, numberScanPixels

          scanAngles(i) = scanAngle1 + (i - 1) * delta ! scan angles

          do 20 j = 1, numberDataChannels
              if(calibratedData(i,j) .NE. missing) then
                  radiance(j) = calibratedData(i,j) * scalefac(j)
              else
                  radiance(j) = badData
              endif
20         continue

          write(*, 25) i, scanAngles(i),
&              (radiance(k), k = 1, numberDataChannels)
25         format(1x,i3,1x,f8.3,8f8.2)

10     continue

      END

```

Applications that need netCDF or multifile SDS functionality should link with both libraries 'libmfhdf.a' and 'libdf.a' in this order, **the order is critical**. To compile the sample program nchdfrac.f, use:

```
f77 -o nchdfrac nchdfrac.f -L -lmfhdf -ldf -lz
```

6. Examples of Scientific Results

6.1 Diffusion Domain Studies

One primary area of cloud research with the CAR instrument is the diffusion domain studies of optically thick and horizontally extended (e.g., marine stratocumulus) cloud decks. From a position deep within an optically thick and horizontally extensive cloud layer, it is possible to derive quantitative information about cloud absorption properties from angular distribution of scattered radiation (King 1981). Within this region, known as the diffusion domain, the diffuse radiation field assumes an asymptotic form characterized by rather simple properties.

Figure 4 represents how the expected signal should appear when in the diffusion domain. Two main features are:

- The angular intensity field at the shortest wavelength follows very nearly the cosine function expected for conservative scattering in the diffusion domain.
- The angular intensity field becomes increasingly anisotropic as absorption increases. This is especially noticeable at 2.00 μm , where water has the greatest absorption.

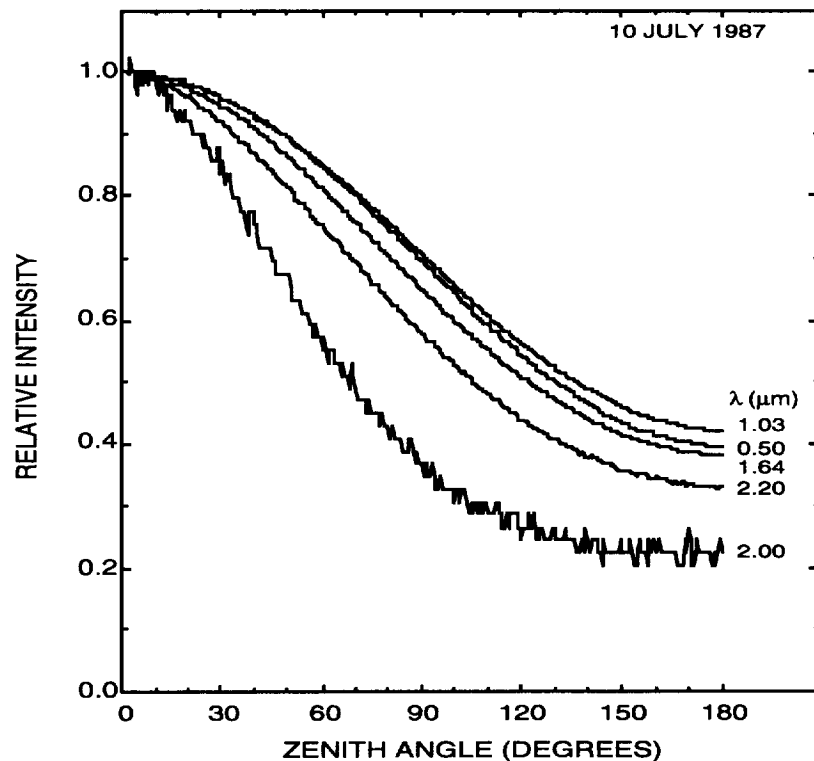

Figure 4. CAR relative intensity as a function of scan angles in the diffusion domain (10 July 1987).

6.2 Bidirectional Reflection Distribution Function Studies

Another application of the CAR is to measure bidirectional reflection distribution functions (BRDFs). To accomplish this, the aircraft assumes a closed circular flight pattern, as sketched in Figure 5, over a uniform surface of interest (e.g., ocean, snow, tundra, etc.). The pilot attempts to maintain a constant altitude near 2000 feet, with a uniform aircraft speed, and a roll angle of 20° . Unlike any ground-based BRDF measuring instrument, which characterizes BRDF over an area no larger than tens of meters in diameter, the CAR can survey the BRDF characteristics of a region on the order of kilometers in diameter.

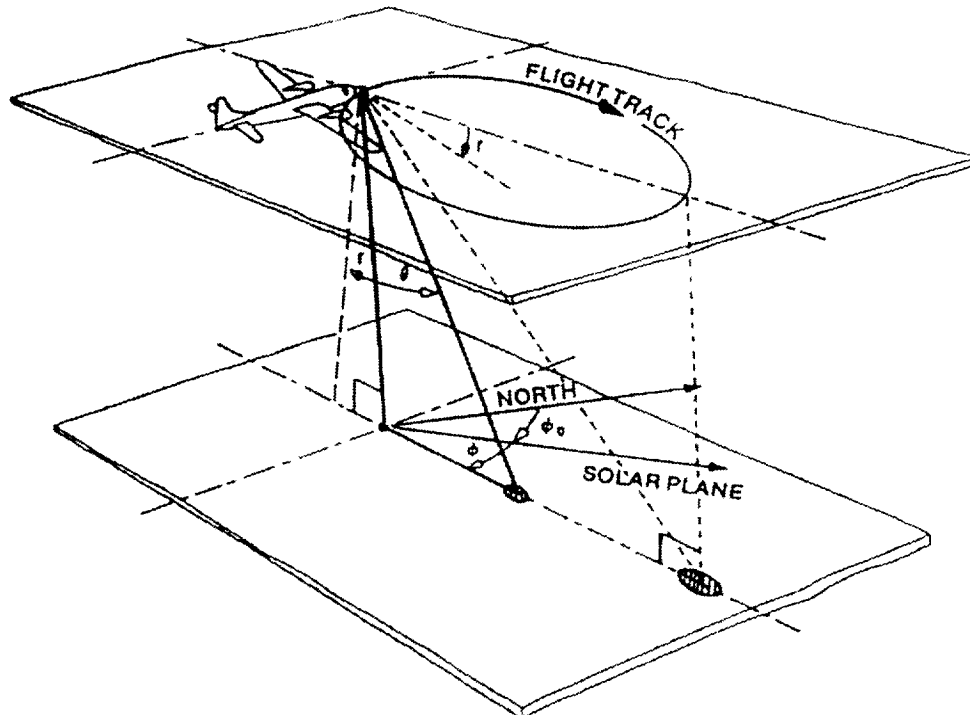

Figure 5. To acquire BRDF data, the C-131A flies in a closed circular flight pattern, banking to the right.

Figure 6 shows the BRDF pattern of a cerrado surface that is highly symmetrical around the principal plane and has a clear reflection in the antisolar direction. When these measurements were made, the Sun was illuminating the scene at an average solar zenith of 59° . The observed strong backscattering peak around 60° viewing zenith angles in the principal plane is known as the *hot spot* or *opposition surge*. In this case ($0.87 \mu\text{m}$), the BRDF has a value as high as 56%. The surface anisotropy retains a similar pattern but becomes less pronounced in the visible region because of chlorophyll absorption (Tsay 1996).

Figure 7 or 8 is a BRDF plot for a dense smoke layer. The plot was constructed using the data set collected on September 6, 1995, near Porto Velho, Brazil. It reveals even better symmetry around the principal plane. However, the bright spot diminished due to a weak direct backscattering peak (glory) and an enhancement in multiple scattering.

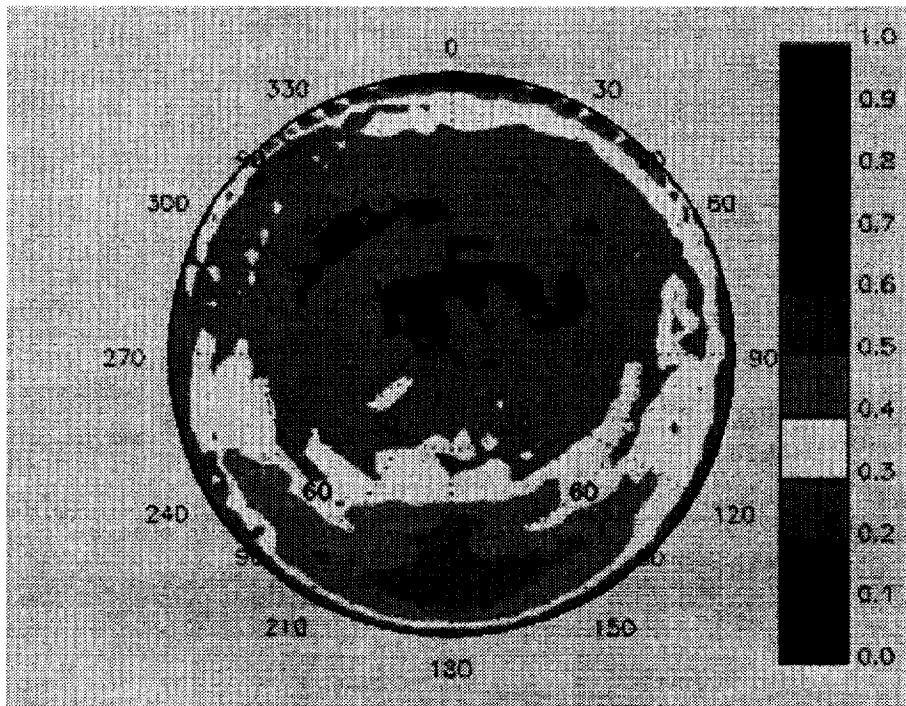

Figure 6. Measurements of the BRDF at $0.87 \mu\text{m}$ over cerrado surface (August 18, 1995), Brasilia, Brazil.

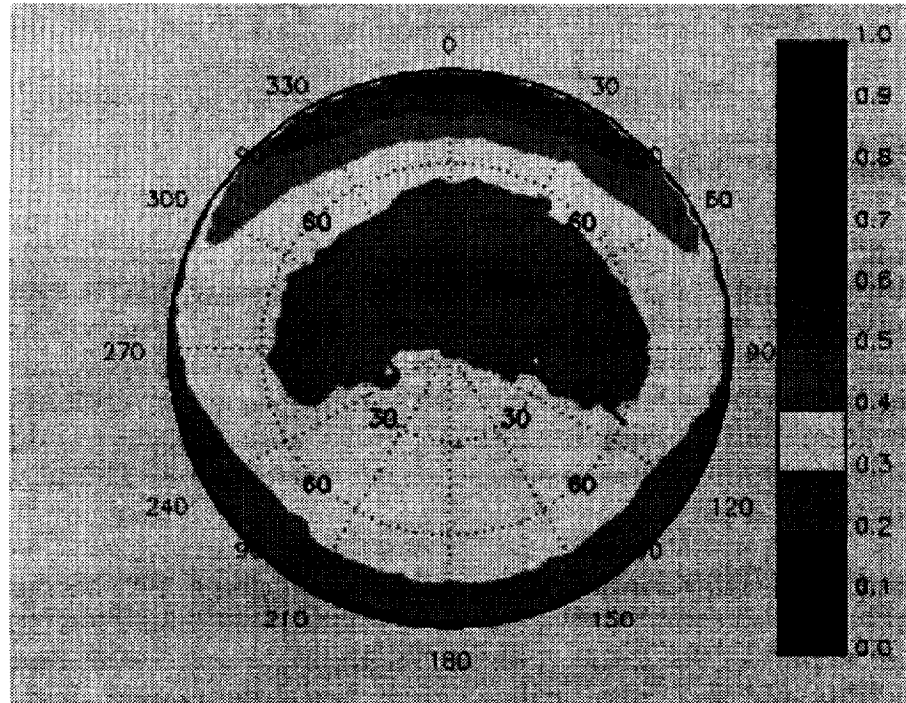

Figure 7. Measurements of the BRDF at $0.87 \mu\text{m}$ over a uniform smoke layer (September 6, 1995), Porto Velho, Brazil.

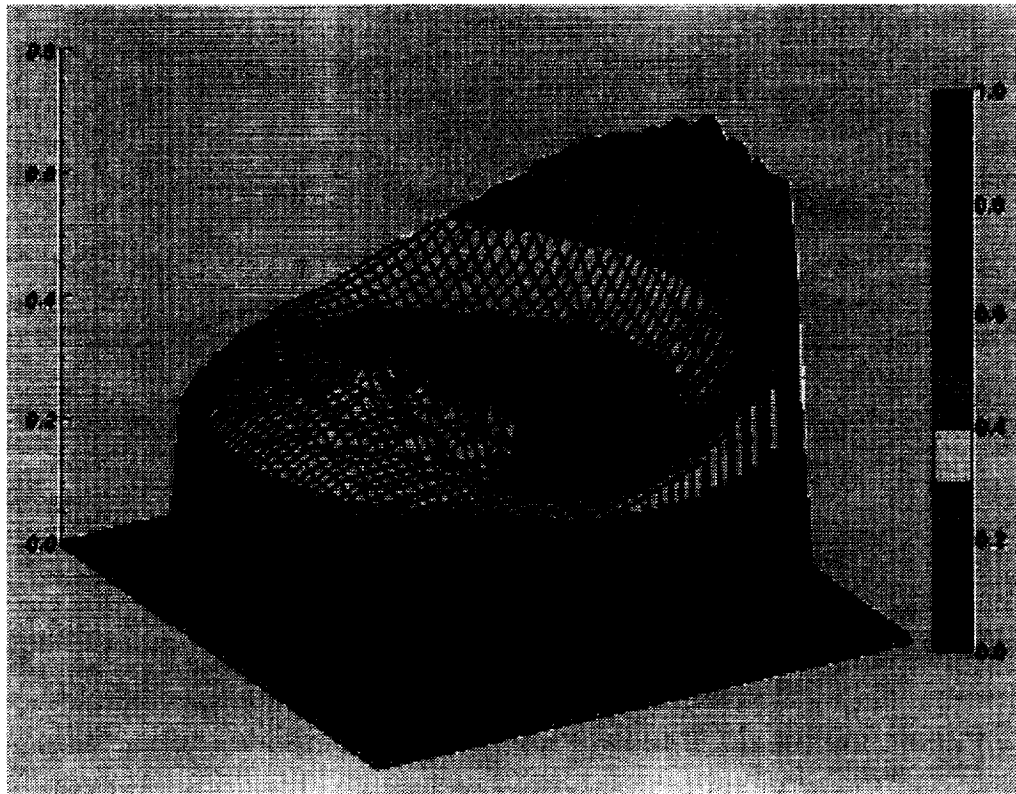

Figure 8. Same as in Figure 7 except presented as a 3D surface plot.

6.3 Multi-spectral Imaging

A third use of the CAR instrument is as a downward-looking imager. It supplements another airborne imaging system, the MODIS Airborne Simulator (MAS). In a downward-imaging configuration, the CAR is rotated 90° around the aircraft's principal axis from its usual starboard viewing position. The scan mirror scans 190° from the starboard horizon, past the nadir and then the port side horizon. To acquire good quality Earth-view images and simplify geometric corrections for postflight image processing, the C-131A aircraft should maintain straight flight track at constant aircraft speed, constant altitude, zero pitch and roll angle whenever possible.

The CAR imaging capability was first demonstrated on September 4, 1995, during a transit flight (Flight 1698) from Cuiabá to Porto Velho, SCAR-Brazil. Figure 9 is a CAR quick-look image (0.86 μm) for that historical flight. The horizontal axis denotes the time code HH:MM in UTC, and the vertical axis is the viewing angle, ranging from 90° (the starboard horizon) to 270° (the port side horizon). The airplane travels, on average, 25 meters between the first and the last scan pixels within a CAR active scan, and 48 meters between scans. To avoid oversampling at nadir, the aircraft's cruising altitude should be

below 2750 meters. In the case shown, the average altitude is 4500 meters, corresponding to an 80-meter footprint at nadir.

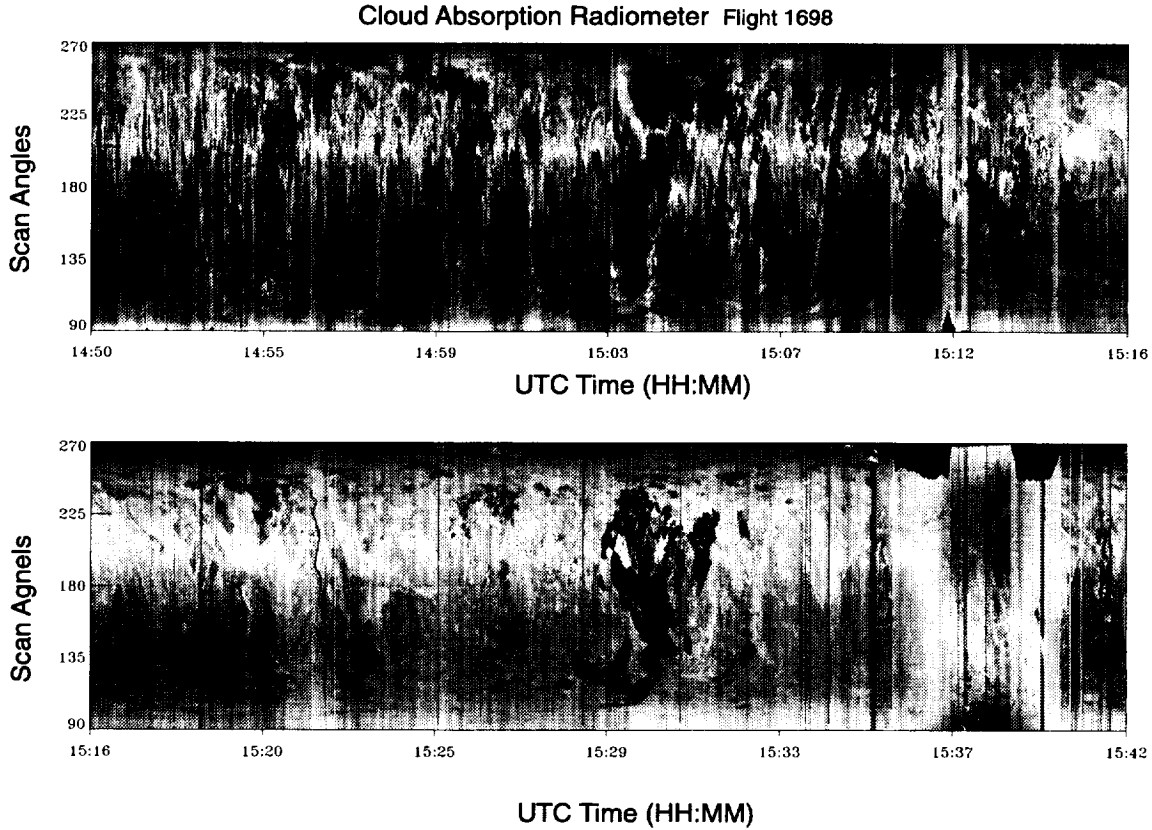

Figure 9. CAR 0.86 μm Earth-view image, flight 1698, September 4, 1995, SCAR-B field experiment.

7. CAR Contact List

Below is a list of persons involved with the processing and analysis of CAR data.

Dr. Michael King (Principal Investigator)
Code 900, NASA Goddard Space Flight Center
Greenbelt, MD 20771
(301) 286-8228, king@climate.gsfc.nasa.gov

Dr. Si-chee Tsay (Research Scientist)
Code 913, NASA Goddard Space Flight Center
Greenbelt, MD 20771
(301) 286-9710, tsay@climate.gsfc.nasa.gov

Mr. Tom Arnold (CAR Calibration)
Code 913, NASA Goddard Space Flight Center
Greenbelt, MD 20771
(301) 286-4805, arnold@climate.gsfc.nasa.gov

Mr. Jason Li (Data Processing and Analysis)
Code 913, NASA Goddard Space Flight Center
Greenbelt, MD 20771
(301) 286 1029, jyli@climate.gsfc.nasa.gov

Mr. Ward Meyer (Data Processing and Analysis)
Code 913, NASA Goddard Space Flight Center
Greenbelt, MD 20771
(301) 286-4591, meyer@climate.gsfc.nasa.gov

Dr. Robert Pincus (Research Scientist)
Code 913, NASA Goddard Space Flight Center
Greenbelt, MD 20771
(301) 286-8272, pincus@climate.gsfc.nasa.gov

Dr. Peter Soulen (Research Scientist)
Code 913, NASA Goddard Space Flight Center
Greenebelt, MD 20771
(301) 286-1008, soulen@climate.gsfc.nasa.gov

8. References

- King, M. D., 1981: A method for determining the single scattering albedo of clouds through observation of the internal scattered radiation field. *J. Atmos. Sci.*, **38**, 2031–2044.
- King, M. D., M. G. Strange, P. Leone, and L. R. Blaine, 1986: Multiwavelength scanning radiometer for airborne measurements of scattered radiation within clouds. *J. Atmos. Oceanic Technol.*, **3**, 513–522. King, M. D. (1981). *J. Atmos. Sci.* **38**, 2031–2044.
- King, M. D., L. F. Radke and P. V. Hobbs, 1990: Determination of the spectral absorption of solar radiation by marine stratocumulus clouds from airborne measurements within clouds. *J. Atmos. Sci.*, **47**, 894–907.
- King, M. D., 1992: Directional and spectral reflectance of the Kuwait oil-fire smoke. *J. Geophys. Res.*, **97**, 14545–14549.
- King, M. D., L. F. Radke, and P. V. Hobbs, 1993: Optical properties of marine stratocumulus clouds modified by ships. *J. Geophys. Res.*, **98**, 2729–2739.
- King, M. D., 1993: Radiative properties of clouds. *Aerosol-Cloud-Climate Interactions*, P. V. Hobbs, Ed., Academic Press, 123–149.
- Radke, L. F., J. A. Coakley, Jr., and M. D. King, 1989: Direct and remote sensing observations of the effects of ships on clouds. *Science*, **246**, 1146–1149.
- Nakajima, T., and M. D. King, 1990: Determination of the optical thickness and effective particle radius of clouds from reflected solar radiation measurements. Part I: Theory. *J. Atmos. Sci.*, **47**, 1878–1893.
- Nakajima, T., M. D. King, J. D. Spinhirne, and L. F. Radke, 1991: Determination of the optical thickness and effective particle radius of clouds from reflected solar radiation measurements. Part II: Marine stratocumulus observations. *J. Atmos. Sci.*, **48**, 728–750
- Tsay, S.C, M. D. King, and J. Y. Li, 1996: SCAR-B airborne spectral measurements of surface anisotropy. *SCAR-B Science Symposium 96*, Fortaleza, Brazil.

Appendix A. On-Line Resources

1. CAR Information Server:

This WWW home page located at <http://climate.gsfc.nasa.gov/~jyli/CAR.html>. Click on the navigation bar at the bottom of the main web page, you can obtain:

- a description of the CAR instrument;
- information on field experiments, data distributions, and examples of scientific results;
- programs for reading and visualizing the CAR HDF data;
- a list of references;
- contact information.

Wherever appropriate, links to other relevant web sites are also provided by this primary CAR information server.

2. Anonymous FTP site:

You may obtain a test CAR HDF data file and sample programs directly from the CAR web site, or by anonymous FTP to climate.gsfc.nasa.gov, then

login: ftp

password: <your-email-address>

change directory to `pub/jyli/CAR`

download README file for more detailed information.

REPORT DOCUMENTATION PAGEForm Approved
OMB No. 0704-0188

Public reporting burden for this collection of information is estimated to average 1 hour per response, including the time for reviewing instructions, searching existing data sources, gathering and maintaining the data needed, and completing and reviewing the collection of information. Send comments regarding this burden estimate or any other aspect of this collection of information, including suggestions for reducing this burden, to Washington Headquarters Services, Directorate for Information Operations and Reports, 1215 Jefferson Davis Highway, Suite 1204, Arlington, VA 22202-4302, and to the Office of Management and Budget, Paperwork Reduction Project (0704-0188), Washington, DC 20503.

1. AGENCY USE ONLY (Leave blank)		2. REPORT DATE March 1997	3. REPORT TYPE AND DATES COVERED Technical Memorandum	
4. TITLE AND SUBTITLE The Cloud Absorption Radiometer HDF Data User's Guide			5. FUNDING NUMBERS C-1269-25 Code 913	
6. AUTHOR(S) Jason Y. Li, Howard G. Meyer, G. Thomas Arnold, Si-Chee Tsay, and Michael D. King				
7. PERFORMING ORGANIZATION NAME(S) AND ADDRESS (ES) Goddard Space Flight Center Greenbelt, Maryland 20771			8. PERFORMING ORGANIZATION REPORT NUMBER 97B00041	
9. SPONSORING / MONITORING AGENCY NAME(S) AND ADDRESS (ES) National Aeronautics and Space Administration Washington, DC 20546-0001			10. SPONSORING / MONITORING AGENCY REPORT NUMBER NASA TM-104643	
11. SUPPLEMENTARY NOTES Li and Arnold: Applied Research Corporation, Landover, Maryland Meyer: Science Systems and Applications, Landover, Maryland Tsay and King: Goddard Space Flight Center, Greenbelt, Maryland				
12a. DISTRIBUTION / AVAILABILITY STATEMENT Unclassified - Unlimited Subject Category 31 Availability: NASA CASI (301) 621-0390.			12b. DISTRIBUTION CODE	
13. ABSTRACT (Maximum 200 words) The purpose of this document is to describe the Cloud Absorption Radiometer (CAR) Instrument, methods used in the CAR Hierarchical Data Format (HDF) data processing, the structure and format of the CAR HDF data files, and methods for accessing the data. Examples of CAR applications and their results are also presented. The CAR instrument is a multiwavelength scanning radiometer that measures the angular distributions of scattered radiation.				
14. SUBJECT TERMS User's Guide, Cloud Absorption Radiometer, Remote Sensing, Airborne			15. NUMBER OF PAGES 44	
			16. PRICE CODE	
17. SECURITY CLASSIFICATION OF REPORT Unclassified	18. SECURITY CLASSIFICATION OF THIS PAGE Unclassified	19. SECURITY CLASSIFICATION OF ABSTRACT Unclassified	20. LIMITATION OF ABSTRACT UL	