



Advanced Technology Composite Fuselage—Program Overview

*L. B. Ilcewicz, P. J. Smith, C. T. Hanson, T. H. Walker, S. L. Metschan, G. E. Mabson,
K. S. Willden, B. W. Flynn, D. B. Scholz, D. R. Polland, H. G. Fredrikson, J. T. Olson,
and B. F. Backman*
The Boeing Company • Seattle, Washington

NOTICE

FOR EARLY DOMESTIC DISSEMINATION

Because of its significant early commercial potential, this information, which has been developed under a U.S. Government program, is being disseminated within the United States in advance of general publication. This information may be duplicated and used by the recipient with the express limitation that it not be published. Release of this information to other domestic parties by the recipient shall be made subject to these limitations.

Foreign release may be made only with prior NASA approval and appropriate export licenses. This legend shall be marked on any reproduction of this information in whole or in part.

Date for general release April 30, 1999

Printed copies available from the following:

NASA Center for AeroSpace Information
800 Elkridge Landing Road
Linthicum Heights, MD 21090-2934
(301) 621-0390

FOREWORD

This document is one of nine complementary final technical reports on the development of advanced composite transport fuselage concepts. The work described was performed by the Boeing Commercial Airplane Group, Seattle, Washington, from May 1989 through December 1995 under contracts NAS1-18889 and NAS1-20013, Task 2. The contracts were sponsored by the National Aeronautics and Space Administration, Langley Research Center (NASA-LaRC) as part of the Advanced Composite Technology (ACT) program. Direction from NASA-LaRC was provided by M.J. Shuart, J.G. Davis, W.T. Freeman, and J.B. Nelson.

The nine documents comprising the final documentation for the NASA/Boeing ATCAS program include:

Advanced Technology Composite Fuselage

- **Program Overview (CR-4734).** *Synopsis of program approach, timeline and significant findings. Design synthesis considering manufacturing, materials, processes, structural performance, maintenance, and cost.*
- **Manufacturing (CR-4735).** *Baseline manufacturing and assembly approaches. Process and tooling developments, and manufacturing demonstration activities to address critical manufacturing issues.*
- **Materials and Processes (CR-4731).** *Baseline and alternative materials and processes. Material and process developments. Material performance.*
- **Structural Performance (CR-4732).** *Methods used for design sizing. Analysis and test activities supporting assessment of design development methodologies for critical performance issues.*
- **Repair and Damage Assessment Supporting Maintenance (CR-4733).** *Maintenance considerations in design. Detailed repair concepts for quadrant design. Fabrication, inspection, and analytical developments.*

Cost Optimization Software for Transport Aircraft Design Evaluation (COSTADE)

- **Overview (CR-4736).** *Synopsis of COSTADE initiative, including integration of cost, weight, manufacturing, design, structural analysis, load redistribution, optimization, and blending.*
- **Design Cost Methods (CR-4737).** *Components of cost analysis and their interactions. Theoretical framework for process-time prediction. Methods for developing and maintaining cost equations. Applications to ATCAS quadrant designs.*
- **User's Manual (CR-4738).** *COSTADE user instructions, including hardware requirements and installation procedures. Program structure, capabilities, and limitations. Basis of cost model and structural analysis routines. Example problems.*
- **Process Cost Analysis Database (CR-4739).** *Rationale for database framework. Database user's guide, including capabilities and limitations. ATCAS process step equations.*

Use of commercial products or names of manufacturers in this report does not constitute official endorsement of such products or manufacturers, either expressed or implied, by the Boeing Company or the National Aeronautics and Space Administration.

At completion of these contracts, Boeing program management included Bjorn Backman as Program Manager, Peter Smith as Technical Manager, and Larry Ilcewicz as Principal Investigator. Authors listed for this contractor report prepared portions of the document. The members (past and present) of the Boeing ACT contract team who contributed to the work described in this document include:

Program Management: Phil Whalley Ron Johnson Ray Horton Jordan Olson Bjorn Backman	Technical Aide: Bill Waltari	Developmental Manufacturing: Jose Valdez Ponci Puzon Bonnie Luck
Technical Management: Peter Smith	Materials and Processes: Dodd Grande David Scholz Karl Nelson Tony Falcone Brian Perkins	Test Laboratories: Ron Slaminko John Schneider Carl Preuss Joan Dufresne Tony Phillips Dan Moreillon Bill Hardrath
Principal Investigators: Randy Coggeshall Larry Ilcewicz	Manufacturing Technology: Tom May Kurtis Willden Val Starkey Tim Davies Mark Gessel Joe Hafenrichter Bob Matetich Ken Goodno Dick Curran Ken Dull Rob Biornstad Peter Lohr Stan Stawski Chris Harris Greg Bell Jan Koontz Rob Synder Tom Cundiff Gary Moon	Business Management: Jeff Heineman Marge Apeles Kira Goerlich
Structural Design: George Truslove Chris Hanson Ken Griess Mike Schram Stephen Metschan Mike Morris Tuan Le		QC and NDE Development: Ken Mackey Brian Lempriere Bill Fortig John Linn
Computing Support: Bob Lundquist Bill Koch Sterling Johnston		Weights: Glenn Parkan
Structural Analysis: Tom Walker Ernie Dost Gary Swanson Blake Flynn Gerald Mabson David Carbery Scott Finn Dan Murphy Bernhard Dopker David Polland William Avery Jerry Bodine Doug Graesser Andre Williams Mark Fedro Peter Grant Adam Sawicki Pierre Minguet	Cost Analysis: Kent Venters Will Gaylord Cal Pfahl David Tervo Len Witonsky Odo Bormke Robert Humphrey Michael Proctor Hans Fredrikson Dennis Stogin	Repair Development: Bert Bannink Mike Evens Sherry Marrese
	Fire Worthiness: Jim Peterson Thomas Murray	Customer Support: Dave Berg Jeff Kollgaard
		Materiel: Maureen Hughes Mark Jones Steve Ruth Doug Wood Christal Tyson-Winston Howard Lanie Mark McConnell Tom Hesketh

Industry And University Design-Build-Team Members

University of Washington:

Kuen Y. Lin
James Seferis
Zelda Zabinsky
Mark Tuttle

Stanford University:

Fu-Kuo Chang

Oregon State University:

Tim Kennedy

M.I.T.:

Paul Lagace
Tim Gutowski
David Hoult
Greg Dillon
Hugh McManus

Drexel University:

Jonathan Awerbuch
Albert Wang
Alan Lau
Frank Ko

University of Iowa:

Roderic Lakes

University of Utah:

William Bascom
John Nairn

University of Wyoming:

Donald Adams
Rhonda Coguill
Scott Coguill

U. of Cal. Santa Barbara:

Keith Kedward

Univ. of British Columbia:

Anoush Poursartip

Brigham Young University:

Ken Chase

San Jose State University:

Robert Anderson

Dow-UT:

Rich Andelman
Douglas Hoon

Sikorsky Aircraft:

Christos Kassapoglou

Northrop/Grumman:

Ravi Deo
Steve Russell
Bob Ley
Ram Vastava
Ram Ramkumar

McDonnell Douglas:

Benson Black

Lockheed Aero. Systems:

Tony Jackson
Ron Barrie
Bob Chu
Dan Skolnik
Jay Shukla
Bharat Shah
Lowell Adams
Lisa Ott

Fiber Innovations:

Steve Goodwin
Garrett Sharpless

Hercules Materials Co.:

Doug Cairns
David Cohen
Roger Stirling
Lynn Muir
Will McCarvill
Yas Tokita

Alliant Techsystems:

Carroll Grant
George Walker
Tammy Harris
Todd Brown
Mark Wheeler
Jon Poesch
Vern Benson

American Airlines:

Jim Epperson
Marcus Peter

Northwest Airlines:

Jim Oberg
Erik Restad
Mark Wolf

United Airlines:

Bob Bernicchi
John Player

Cherry Textron:

Howard Gapp

Sunstrand:

Glen Smith
Hossein Saatchi
Bill Durako

ICI Fiberite:

Erinann Corrigan
Russ Holthe

G.M.I.:

Roland Chemana

Intec:

Brian Coxon
Chris Eastland
Rod Wishart
Shreeram Raj
Don Stobbe

Zetec:

Chuck Fitch
Gregg Colvin

Draper Laboratory:

Ed Bernardon

Hexcel:

Stacy Biel
Julaine Nichols
Kevin Marshal

E. I. Du Pont De Nemours:

Jim Pratte
Hal Loken
Ginger Gupton

Materials Science Corp.:

Walt Rosen
Anthony Caiazzo

Structural Consultant:

John McCarty

EBCO Tooling:

Rich Roberts

TABLE OF CONTENTS

1.0	ABSTRACT	1-1
2.0	INTRODUCTION	2-1
2.1	BENEFITS FROM NASA FUNDING	2-1
2.2	ATCAS TEAM MEMBERS	2-3
2.3	DOCUMENT OUTLINE	2-4
3.0	BOEING ADVANCED COMPOSITES	3-1
3.1	TODAY'S TECHNOLOGY	3-1
3.2	FUTURE COMMERCIAL IMPLEMENTATION	3-5
3.2.1	A Path To Future Applications	3-7
3.2.2	Estimated Value of Composite Technology	3-9
4.0	ATCAS PROGRAM SCOPE	4-1
4.1	BASELINE FUSELAGE SECTION	4-1
4.2	FUSELAGE LOAD CONDITIONS	4-3
4.3	SCHEDULE	4-9
4.4	APPROACH	4-11
5.0	QUADRANT CONCEPT DEVELOPMENT	5-1
5.1	CROWN DESIGN AND MANUFACTURING PROCESSES	5-1
5.2	KEEL DESIGN AND MANUFACTURING PROCESSES	5-5
5.3	SIDE DESIGN AND MANUFACTURING PROCESSES	5-8
5.4	LONGITUDINAL AND CIRCUMFERENTIAL SPLICES	5-13
5.5	CRITICAL ISSUES	5-16
5.5.1	Full Barrel Assembly	5-16
5.5.2	Quadrant Fabrication	5-17
5.5.3	Flexible Tooling	5-17
5.5.4	Pre-cured Element Fabrication	5-17
5.5.5	Material & Process Control	5-18
5.5.6	Design Cost Relationships with Manufacturing Processes	5-18
5.5.7	Damage Tolerance	5-18
5.5.8	Strength and Stability	5-19
5.5.9	Internal Load Paths	5-20
5.5.10	Crash and Fire Worthiness	5-20
5.5.11	Systems Attachments and Protection	5-21
5.5.12	Composite to Metal Interface	5-21
5.5.13	Repair	5-21
5.5.14	Inspect and Quantify the Effects of Damage	5-22
5.5.15	Durability	5-22
6.0	COST AND WEIGHT ASSESSMENTS	6-1
6.1	TOTALS FROM DETAILED ESTIMATES VERSUS EXISTING ALUMINUM	6-2
6.2	DESIGN COST MODEL PREDICTIONS	6-6

6.3	CROWN	6-11
6.4	KEEL.....	6-12
6.5	SIDE.....	6-13
6.6	FUTURE QUADRANT CONSIDERATIONS.....	6-14
7.0	SYNOPSIS OF TECHNOLOGY DEVELOPMENT.....	7-1
7.1	MANUFACTURING.....	7-1
7.1.1	Quadrant Fabrication	7-4
7.1.1.1	Crown Panel Scale-up	7-7
7.1.1.2	Keel Panel Scale-up	7-8
7.1.1.3	Side Panel Scale-up	7-10
7.1.2	Precured Element Fabrication	7-11
7.1.3	Flexible Tooling	7-12
7.1.4	Full Barrel Assembly	7-13
7.2	MATERIAL AND PROCESSES	7-13
7.2.1	Tension Strength versus Toughness Trades	7-14
7.2.2	Compression Residual Strength	7-17
7.2.3	Bolted Joints Evaluations	7-19
7.2.4	Material and Process Control	7-20
7.2.5	Composite to Metal Interface	7-22
7.2.6	Fire Worthiness	7-22
7.3	STRUCTURES.....	7-22
7.3.1	Internal Load Paths	7-23
7.3.2	Detailed Strength & Stability Assessments	7-24
7.3.2.1	Crown Panel	7-25
7.3.2.2	Keel Panel	7-25
7.3.2.3	Side Panel	7-27
7.3.2.4	Circumferential and Longitudinal Panel Splices	7-31
7.3.3	Damage Tolerance	7-31
7.3.3.1	Tension Performance	7-32
7.3.3.2	Compression Performance	7-34
7.3.4	Bonded Frame Integrity	7-35
7.4	MAINTENANCE.....	7-38
7.4.1	Inspect and Quantify Effects of Damage	7-39
7.4.2	Sandwich Water Ingression	7-41
7.4.3	Repair	7-43
7.5	DESIGN COST MODEL DEVELOPMENT.....	7-45
7.5.1	Theoretical Framework	7-46
7.5.2	ATCAS Cost Database	7-48
7.5.3	COSTADE Software Utilities	7-50
8.0	CONCLUDING REMARKS.....	8-1
8.1	BENEFITS OF INTEGRATED PRODUCT DEVELOPMENT.....	8-1
8.2	CURRENT STATUS.....	8-2
8.3	RECOMMENDATIONS FOR FUTURE DEVELOPMENT.....	8-5
9.0	REFERENCES	9-1

1.0 ABSTRACT

Advanced composite technologies must earn their way into future commercial aircraft applications by adding value to the product and gaining customer acceptance. Composite technology with both cost and weight saving advantages over aluminum are required. The Advanced Technology Composite Aircraft Structures (ATCAS) program has studied transport fuselage structure with a large potential reduction in the total direct operating costs for wide-body commercial transports. Parallel Boeing development programs have pursued similar improvements for other primary composite structures. The combined databases collected to date suggest that future cost-effective applications are feasible.

Boeing's ATCAS program has successfully completed Phases A and B over a period of six and a half years. The baseline fuselage section used in ATCAS studies has a constant diameter of just over 20 feet and a length of 33 feet. The baseline section is immediately aft of the main landing gear wheel-well bulkhead and is representative of the constant diameter portion of Section 46 on Boeing airplanes. This section was selected because it contains many of the structural details and critical manufacturing issues found in a transport fuselage while avoiding higher program tooling costs for a non-constant section. For example, significant variation in design details occur in the baseline section due to relatively high body bending loads in the forward end which diminish, allowing transition to minimum-gage structure, in the aft end.

The baseline fuselage section was divided into four "quadrants", gaining the manufacturing cost saving advantage possible with larger composite panels. Crown (top panel), keel (belly panel), and side (including the passenger door and windowbelt) quadrant studies were performed sequentially over the course of the program. Key processes found to have the desired cost savings potential include (1) skins laminated by automatic fiber placement, (2) braided frames cured using resin transfer molding, and (3) panel bond technology that minimized mechanical fastening.

The design build team (DBT) approach used in ATCAS has been staged by continuous value assessments of the composite concepts under development. The cost and weight of the baseline fuselage barrel was updated to complete Phase B of the program. An assessment of the former, which included labor, material, and tooling costs, was performed with the help of design cost models developed under ATCAS. Crown, keel, and side quadrant cost distributions illustrate the importance of panel design configuration, area, and other structural details. Composite sandwich panel designs were found to have the greatest cost savings potential for most quadrants.

Key technical findings from ATCAS are summarized as an introduction to the other contractor reports documenting Phase A and B work completed in functional areas. The current program status in resolving critical technical issues is also highlighted.

2.0 INTRODUCTION

Boeing's Advanced Technology Composite Aircraft Structures (ATCAS) program (contract NAS1-18889) was initiated in May 1989 as an integral part of the NASA sponsored Advanced Composites Technology (ACT) initiative. Task 2 of Materials Development Omnibus Contract (MDOC, contract NAS1-20013) was awarded in November 1993 to extend the ATCAS work. Combined, these two contracts addressed concept selection and technology development (referred to as Phases A and B). An additional contract (NAS1-20553, referred to as Phase C) has been initiated to verify this technology at a large scale.

The primary focus of ATCAS has been to develop composite transport fuselage structure with significant cost savings over current aluminum technology. This, combined with composite weight advantages, indicate a large potential for future aircraft structure having increased value. The multi-functional ATCAS team achieved significant technology advancements during Phases A and B, spanning a timeframe from 1989 through 1995. This program has benefited greatly from NASA program and technical support in addressing numerous issues for selected composite fuselage concepts.

2.1 Benefits from NASA Funding

World dominance in transport aircraft sales by US. industry is threatened by foreign competitors. The lower left corner of Figure 2-1 shows the European consortium, Airbus Industrie, has captured market share at the expense of US. manufacturers. Boeing has remained the only US. aircraft manufacturer to meet the Airbus challenge without loss of market share. US. government research funding, such as the NASA ACT program, helps Boeing and other US. aircraft manufacturers to develop advanced technology and remain competitive in world markets.

Figure 2-1 shows one estimate of the world market for new commercial transport aircraft from 1995 through 2015. This estimate, which includes passenger and cargo transports, indicates a significant expansion in an already vital world market. Statistics shown in Figure 2-1 indicate the estimated worth of every one percent in market share over this time frame. It is nearly impossible to project increased commercial aircraft market share based on technology improvements without making major assumptions (e.g., customer needs, the competition's technology, and future business strategies). Assuming Boeing's current market share is maintained, Figure 2-1 shows large benefits to the US. economy in terms of revenue, jobs, and tax base.

Boeing is the world's largest producer of commercial transport aircraft, maintaining a market share of over 57% for the world and over 80% for the United States. This provides a large benefit to the US. economy. Approximately 75% of Boeing sales are exports, helping to reduce the US. trade deficit. Every \$1 billion in US. airplane sales creates about 30,000 labor years of work, of which 87% is performed in the US. The Boeing Commercial Airplane Group has spent up to \$10 billion a year on goods and

services produced by over 5,000 suppliers throughout the United States (see Figure 2-2). Maintenance of the United States aircraft industry's market position is critical for the preservation of high paying skilled jobs, a capable industrial base, and balance of trade.

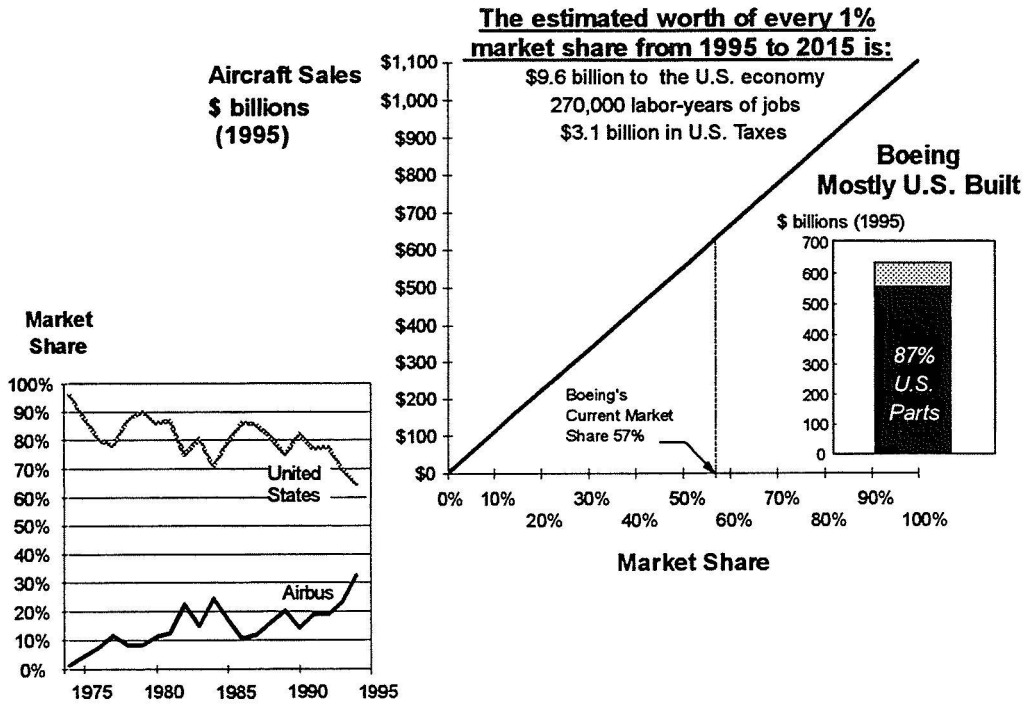

Figure 2-1: Estimates of future commercial transport market.

Average yearly purchases from U.S. suppliers in peak years (1987 - 1992)

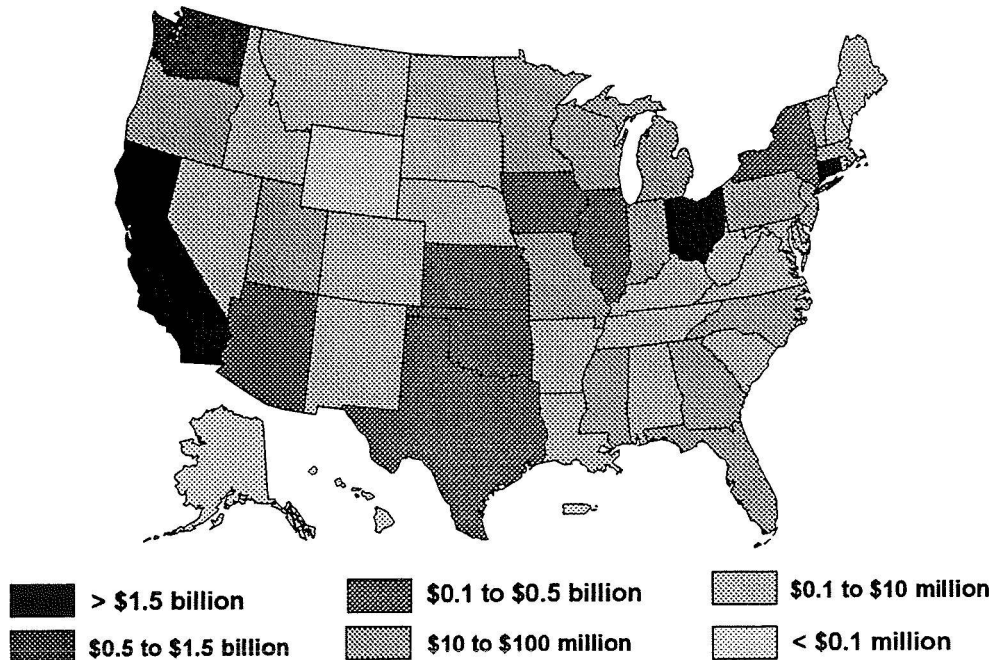

Figure 2-2: Boeing links to US suppliers.

2.2 ATCAS Team Members

As shown in Figure 2-1, Boeing airplanes are mostly built within the US. Nearly all states of the union benefit from Boeing's commercial transport aircraft market share. Figure 2-2 plots Boeing's average yearly purchases from suppliers in each state during recent peak sales years. Similarly, the ATCAS program also established teaming relationships with numerous industries and universities throughout the US. Organizations which supported ATCAS during the course of the program are shown in Figure 2-3. Key members from many of these organizations are listed in the Foreword of this Contractor Report. The combination of unique talents within all these organizations has proven very effective for technology development of composite fuselage structure.

University subcontracts supported by the ATCAS program (see Figure 2-3) reflect Boeing's commitment to college relations. Several lessons learned from university subcontracts are worthy of note. First, it is best to select baseline design & manufacturing concepts, define related technical issues, and collect some hardware data before establishing a subcontract. In other words, define problems that relate to the program focus. Second, the solution to many relevant problems require a multidiscipline approach, highlighting the need for close coordination between the design build team (DBT) members at Boeing and those performing the subcontract. Finally, sufficient manpower and time must be allocated to facilitate technology transfer between industry and academia. Schools which encouraged student co-op programs, and graduate students or faculty with industrial experience, helped minimize the coordination effort and maximize value of the output.

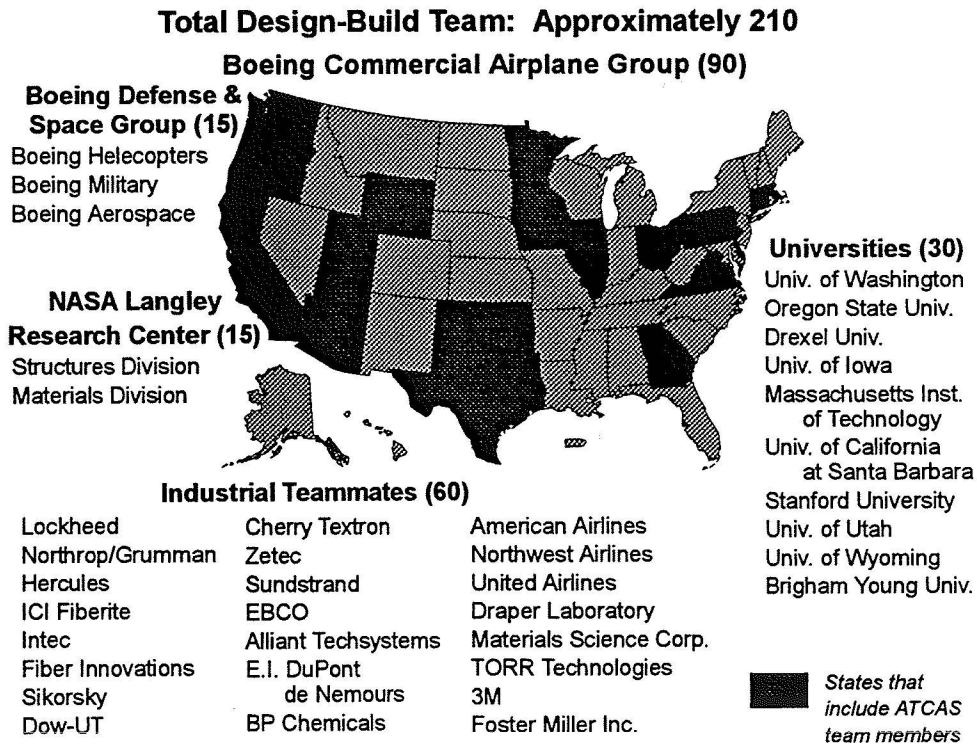

Figure 2-3: US. team members that have supported ATCAS.

2.3 Document Outline

The purpose of this report is fourfold: (1) to define the ATCAS program, (2) to describe baseline concepts, with an emphasis on those designs developed to some degree of validation at the end of Phase B, (3) to summarize cost and weight advantages versus state-of-the-art aluminum, and (4) to report on major technical accomplishments. More detailed accounts of specific functional areas of study can be found in other Boeing Contractor Reports identified in the Foreword. The current report consists of six main parts, Sections 3 through 8.

Section 3 summarizes past, present, and future use of advanced composite materials in Boeing aircraft. The value of affordable composite technology, such as that pursued by ATCAS, is estimated using a measure of the operating costs for wide-body transport aircraft. The technology development stages which must be completed to achieve a level of readiness needed for production commitments are discussed. A forecast of the likely order of future composite implementation in subsonic transport aircraft structure is also presented.

Section 4 provides a description of the ATCAS program scope. This includes a definition of the baseline vehicle, fuselage barrel section, and quadrants. Load paths for the baseline fuselage section are discussed. The schedule and DBT approach followed by ATCAS are also summarized in this section.

Section 5 presents the ATCAS crown, keel, and side quadrant panel concepts, with a special emphasis on design features recommended at the end of Phase B. Critical issues related to cost, design, manufacturing, and maintenance are also identified. Detailed design, manufacturing scale-up, and structural evaluations focused on some critical issues in most areas of the crown and keel quadrants. Studies addressing the side quadrant were primarily focused on the windowbelt.

Section 6 provides final Phase B assessments on the cost and weight of each quadrant. A synthesis of the cost components for each quadrant helps to identify key areas for future development. A comparison of the total barrel cost versus aluminum is also presented in this section.

Section 7 constitutes most of the report, providing a discussion of major program findings in all of the functional areas considered in ATCAS. This includes subsections on manufacturing, materials & processes, structures, maintenance, and the design cost model (worked under the initiative called Cost Optimization Software for Transport Aircraft Design Evaluation, COSTADE).

Section 8 provides a summary of the current status of composite fuselage development and recommendations for future study. Benefits derived from an integrated approach to product development are also discussed.

3.0 BOEING ADVANCED COMPOSITES

3.1 Today's Technology

During the past two decades, Boeing and other US. manufacturers have made large investments in composite technology for military and commercial aircraft structures. The rate of increasing composite implementation has been paced by considerations such as national defense, commercial economics, and resource dilution. US. commercial applications have lagged those of our military by about 10 years, as shown in Figure 3-1.

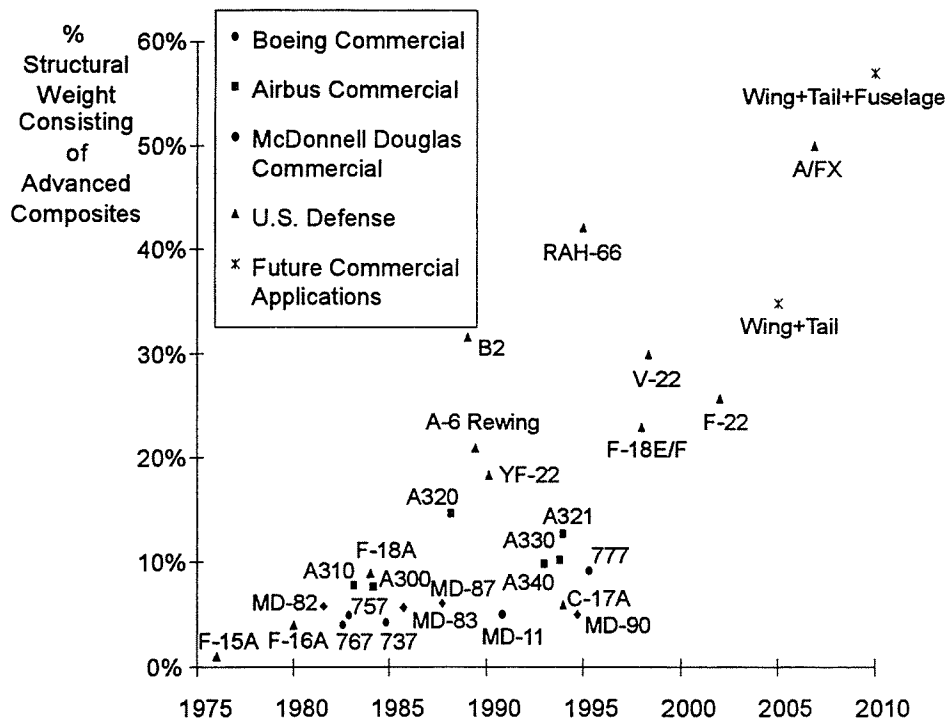

Figure 3-1: Percent use of advanced structural composites.

US. manufacturers' investment in composite research and development (R&D) has been augmented by government aeronautics R&D. This provided the technical basis for several commercial and military production programs. The combination of R&D and production has combined to yield an educated work force, manufacturing centers, equipment, process & material specifications, computing capabilities, design criteria, structures manuals, testing facilities, and supplier/manufacturer relationships.

In the late 1970s and early 1980s, the technical feasibility of composite structure for commercial airframes was evaluated. These studies were justified by potential weight savings and concerns about the rising cost of fuel. Several NASA-funded R&D programs culminated in prototype composite hardware that were certified and flown on Boeing 727 and 737 jets. The most significant of these efforts was five shipsets of 737-200 horizontal stabilizers that were certified in 1982 and entered service in 1984 (see Figure 3-2).

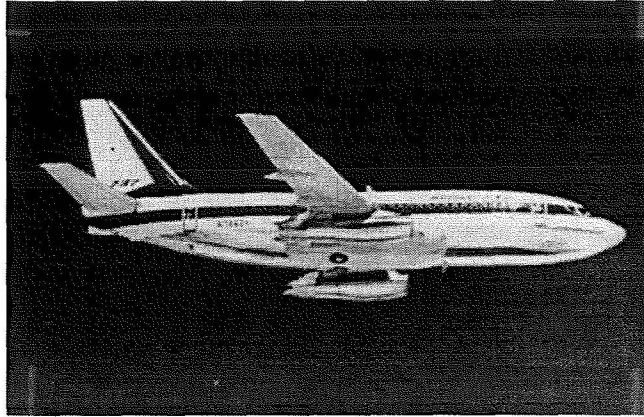

Figure 3-2: Five shipsets of composite horizontal stabilizers have been flown on 737 aircraft.

The NASA-ACEE/Boeing 737-200 composite horizontal stabilizer program, which ran from July 1977 to December 1981, resulted in the first primary structural application of advanced composite materials to a Boeing commercial aircraft. The objectives of this program (refs. 1 and 2, NASA Contract NAS1-15025), were to (1) design and fabricate an advanced composite stabilizer that met the same criteria as those for the existing B737-200 metal stabilizer but with 20% weight saving, and (2) to obtain realistic production cost data. Coupon, element, and subcomponent tests, and full scale ground testing of a left-hand stabilizer were performed to obtain FAA certification for commercial operations. Five shipsets of complete stabilizers were fabricated and assembled to B737-200 aircraft which commenced commercial airline operations in March 1984.

All technical program goals for the NASA-ACEE/Boeing horizontal stabilizer program were achieved. Boeing also obtained significant design, fabrication, assembly, test, and certification experience with composite primary structure during this program. Due to the limited production run, fabrication processes were essentially manual methods and the costs of the 737-200 composite stabilizers were found to not be competitive with metal stabilizers. The integrated team that Boeing formed for this NASA sponsored program proved to be very effective and was used as the model for the 777 composite empennage.

This and other NASA programs, such as the 727 composite elevator program (NAS1-14952) and the 737 spoiler program (NAS1-11668), provided the impetus for some commercial applications (i.e., numerous secondary structures on 737, 757, and 767 Boeing aircraft). However, most of the experience base in the 1980s was directed towards strategic military applications. Much of Boeing's composite resources were applied to primary structures for B2, V-22, and A6 programs shown in Figure 3-3.

Initial Boeing military applications were driven by weight, performance, configuration, and other mission requirements. Boeing's participation with Northrop Corp. and Vought Aerospace in the US. Air Force B2 stealth bomber program included responsibilities for the aft center section and outboard wing sections. Boeing developed and demonstrated composite fuselage and wing technology for the V22 Osprey (partners with Bell-Textron)

under US. Navy contract and is now applying it to the production airplane. The re-wing of A6 aircraft performed by Boeing for the US. Navy represents one of the largest US. composite primary structure production databases (178 shipsets). Boeing also worked with Lockheed under US. Air Force contract to develop and fabricate the first thermoplastic primary structure to be flown (F22 wing and body skin panels).

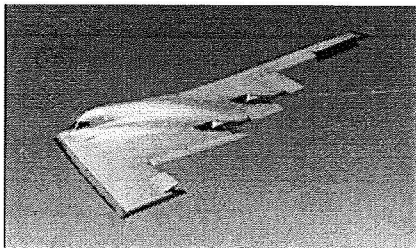

B-2
Largest application
(60-ft wing box)



A-6
Largest production run
(178 wing shipsets)

Boeing was committed to the development and production of composite primary structures for military airplanes during the 1980s.



V-22
Wing and fuselage development

Figure 3-3: Strategic US. defense applications in the 1980s made significant use of composites in primary structures.

Composite flight components fabricated under NASA-ACEE funding have been in service on Boeing commercial aircraft for over twenty years. Service exposure data collected for these parts has not indicated any durability or corrosion problems. For example, Figure 3-4 shows the flight data for the five shipsets of composite horizontal stabilizers that were funded by NASA contract no. NAS1-15025 and entered service in 1984. As shown, these stabilizers have combined for over 133,500 flight hours and 130,000 landings as of May, 1995. A stabilizer from a Markair airplane, that was removed from service in June, 1990 with 17,300 flight hours, was received at Boeing and torn down for inspection. The component was free from any significant fatigue or corrosion damage.

Despite certification of prototype Boeing 737 horizontal stabilizers in 1982, the commitment of resources to high performance military aircraft slowed further commercial developments for the remainder of the 1980s. This allowed Airbus to implement composite empennage on several commercial aircraft prior to Boeing doing so on the 777. Airbus' commercial production experiences with horizontal stabilizers includes fuel containment for A330/340.

Tail No.	Airline	Installation	Hours	Landings
N314DL	Delta	3-13-84	30,455	28,415
N307DL	Delta	3-16-84	30,020	27,918
N670MA*	Markair	5-11-84	17,302	19,295
N671MA	Markair	6-22-84	24,369	22,923
N672MA	Markair	8-18-84	31,360	30,806
			133,500	129,357

* Removed from service in 6/90

Figure 3-4: Flight data for NASA-ACEE/Boeing 737 horizontal stabilizers as of May, 1995.

Slow-downs in military applications by the late 1980s allowed Boeing to commit sufficient composite resources to commercial stabilizer, wing, and fuselage programs. Empennage and wing structures were studied for an unducted fan-powered, 150 passenger, 7J7 aircraft. The former included detailed design, fabrication, and test. Fuselage was addressed in the NASA-funded ATCAS effort which is described in this report. Studies performed for the 7J7, plus subsequent product development for a larger aircraft, provided the technical basis and confidence for Boeing's commitment to commercial production of 777 composite empennage structure. The Boeing 777 empennage completed certification in May, 1995 and several shipsets have recently entered service (see Figure 3-5).

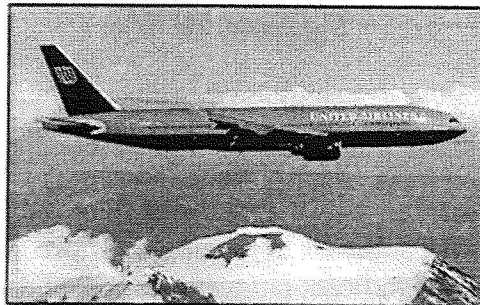

Figure 3-5: Boeing 777 aircraft use composites in primary empennage structure.

Composite development in the 1980s have provided a valuable resource for national defense and a technical foundation for primary aircraft structures. To date, military and commercial benefits of composites on Boeing airplanes include reduced weight (on the order of 20%), improved fatigue performance, and reduced corrosion. Additional military benefits relate to airplane configuration, low observable signature characteristics, stiffness, and dimensional stability.

Boeing's commitment to the 777 composite empennage has provided valuable data from the first large commercial production run. Since 1993, the 777 production program has made significant advancements which will benefit future composite applications at Boeing. The 777 manufacturing facility was brought on-line within cost projections and an aggressive schedule. Large reductions in the fabrication and assembly labor content for early shipsets indicate learning curve improvements which are steeper than previous military experiences. Numerous process and quality improvements have occurred since the start of the program. This includes advancements in assembly technology and design solutions which have led to reduced tooling costs for derivatives in the 777 family of aircraft.

3.2 Future Commercial Implementation

Boeing is committed to producing transport airplanes that reduce total operating costs and increase airline revenue. The Boeing Company designs, manufactures, and provides service support for a family of airplanes that meet customer needs in every commercial transport market. Delivering value has been the key to customer satisfaction in Boeing products. Figure 3-6 shows the current Boeing airplanes, representing 737, 757, 767, 777, and 747 families. Figure 3-7 shows the approximate range and number of seats for aircraft currently available from all major airframe manufacturers. Note that Boeing airplanes span a wider area in the graph than both other manufacturers combined.

Airlines have posed requirements for a number of new technologies, including advanced structural materials such as composites. Composite technology must add economic value by reducing total life cycle costs. Market pressures are forcing this to include lower airplane acquisition costs. Design and production costs for commercial airplanes must be lower. Maintenance costs for composite structures, including lost revenue due to down-time, cannot be greater than aluminum to avoid offsetting performance advantages from lighter weight. The maintenance and repair procedures for composite structures must also not require an extensive investment in special facilities and equipment.

Primary barriers to expanded composite applications in commercial transport wing and fuselage structures are threefold. First, reductions in manufacturing costs are needed to achieve the breakthrough decrease in total life cycle costs desired by airlines. Second, maintenance-related issues for composite structures must be resolved to gain full airline customer acceptance. Third, advancements in composite manufacturing, structures, and maintenance technology must be captured in a production-ready form to support DBTs. Future DBTs will be expected to meet increasingly aggressive timelines for cost-effective product definition and just-in-time production that meets changing market demands.



Figure 3-6: *Current Boeing transport airplanes.*

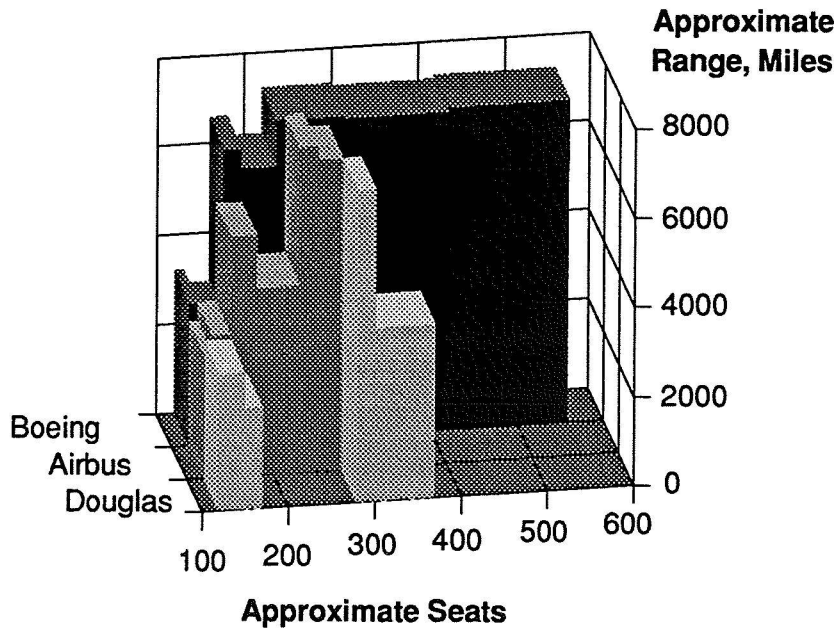

Figure 3-7: *Approximate range and seats for passenger aircraft currently on the market.*

3.2.1 A Path To Future Applications

As shown in Figure 3-7, Boeing's airplane families span the complete range and payload space for transport aircraft. This places Boeing in a unique position when considering new technologies. For example, Boeing desires to continue offering airplanes for this entire space, while seeking commonality between products as an advantage to airline customers. Assuming composite technologies continue to advance and achieve the desired value for future aircraft, the application of primary composite structures to all Boeing families will require time. For example, the current fleet of Boeing airplanes were developed over a period of several decades.

Ongoing production of the 777 empennage, including design and manufacturing solutions for derivative aircraft, provides a strong impetus for future composite applications. For example, this experience will directly establish an acceptable cost for subsequent composite empennage.

Future penetration of composites into the Boeing fleet will be paced by available resources (manpower and facilities) and advancements in technology to achieve superior value. As shown in Figure 3-8, the addition of wing and fuselage structures will likely occur incrementally. Each successive implementation of composite structures will consume more resources. The total resources needed at any one time includes those for new components (e.g., wing or fuselage) and those to sustain applications that subsist (e.g., empennage and secondary structures). As a result, strategic planning and employee training will be needed. This will become even more of an issue with future emphasis on reduced program cycle times.

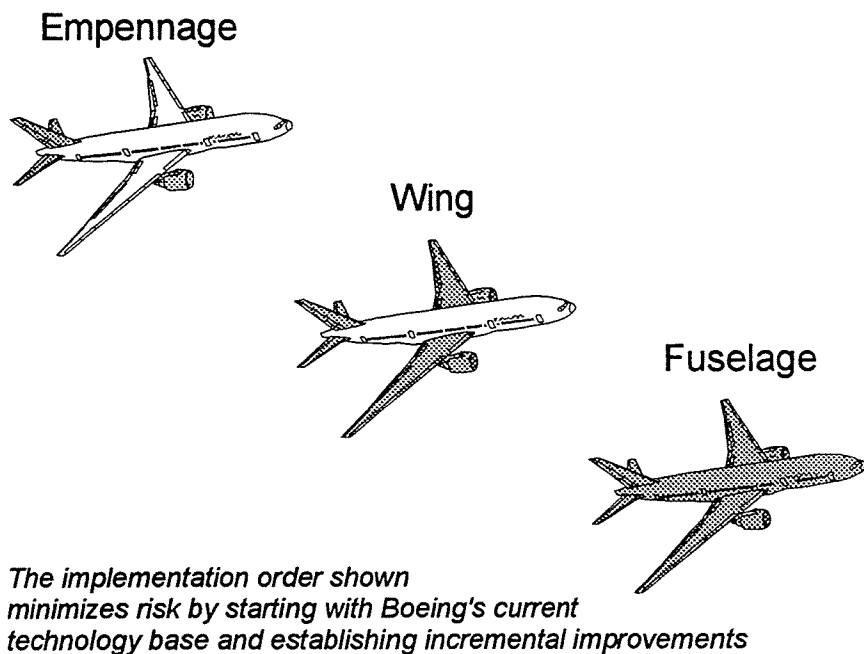

Figure 3-8: *One scenario for implementation of cost-optimized subsonic composite aircraft structures.*

The implementation scenario shown in Figure 3-8 suggests that primary wing structure might be a desirable Boeing application of composites beyond empennage. This is based on the similarity of wing and empennage (i.e., horizontal stabilizer) structures. Another reason for wing before fuselage could be that primary structures constitute approximately 75% of the wing's weight but only about 40% of its cost. Much of the cost of wing structure is in moving parts located in the leading and trailing edges. The effect of composite weight savings can be maximized while costs are incrementally reduced to achieve the value needed for primary wing applications. In fuselage, primary structures constitute most of the cost and weight. As will be discussed later, a composite fuselage also has significantly more technical challenges to solve prior to implementation.

A team was established in 1993 to integrate Boeing's composite development plans for commercial aircraft structures. This team consists of members from existing Boeing production programs, R&D (both internal and government-funded), and customer support. The team determines and updates strategies for composite structures development based on continuous value assessment of the technology, starting with an understanding of current production costs.

Boeing continues to pursue initiatives in each functional area of composite technology development. In manufacturing, processes crucial to achieving total production costs below metals are being pursued. Progress in solving service-related issues is being monitored to help identify the technology developments needed to gain customer acceptance. This includes maintenance R&D to ensure procedures evolve to achieve inspection, repair and down-time costs below metal. Structural design initiatives are focused on the integration of producible and dependable composite design concepts. The technologies discussed throughout this report are an integral part of Boeing's composite development plan.

A Boeing process was established to monitor the cost credibility and maturity of composite technologies. Figure 3-9 shows stages that are part of the process to help guide composite development from initial conception through production. Note that some overlap exists between timelines for each stage (e.g., Stages 3 & 4 are linked to support technology transfer to production). Exit criteria have been defined for every stage to track the progress of key technology deliverables in each functional area. Figure 3-10 shows several examples of potential deliverables.

In order to complete each development stage, Boeing composite initiatives must first provide the necessary data to pass cost evaluations, and second, upgrade technology deliverables to meet goals for the specific stage. Cost evaluation is a crucial task because inputs are required from design, manufacturing, and maintenance. Development funds increase commensurate with more rigorous cost evaluations and technology achievements for each of the first four stages shown in Figure 3-9. The use of representative structure and gated development ensures affordable technology readiness before committing to production. It is also consistent with the goal to develop technology in a form needed to reduce cycle times.

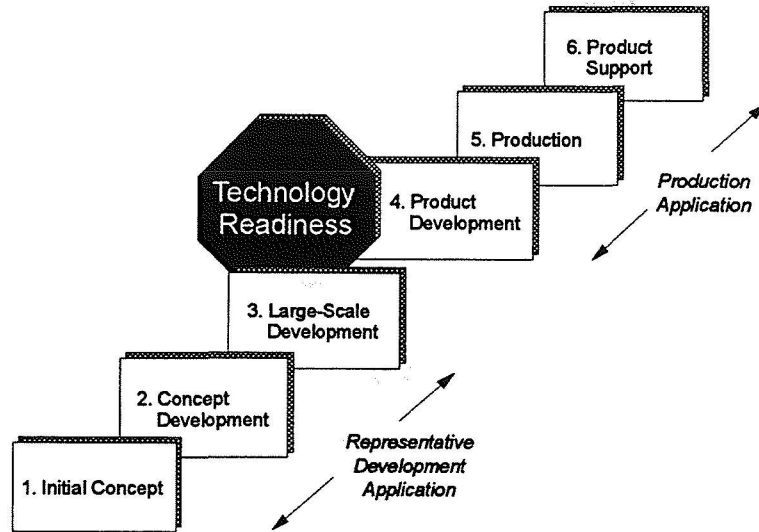

Figure 3-9: Boeing is staging composite development to ensure production readiness.

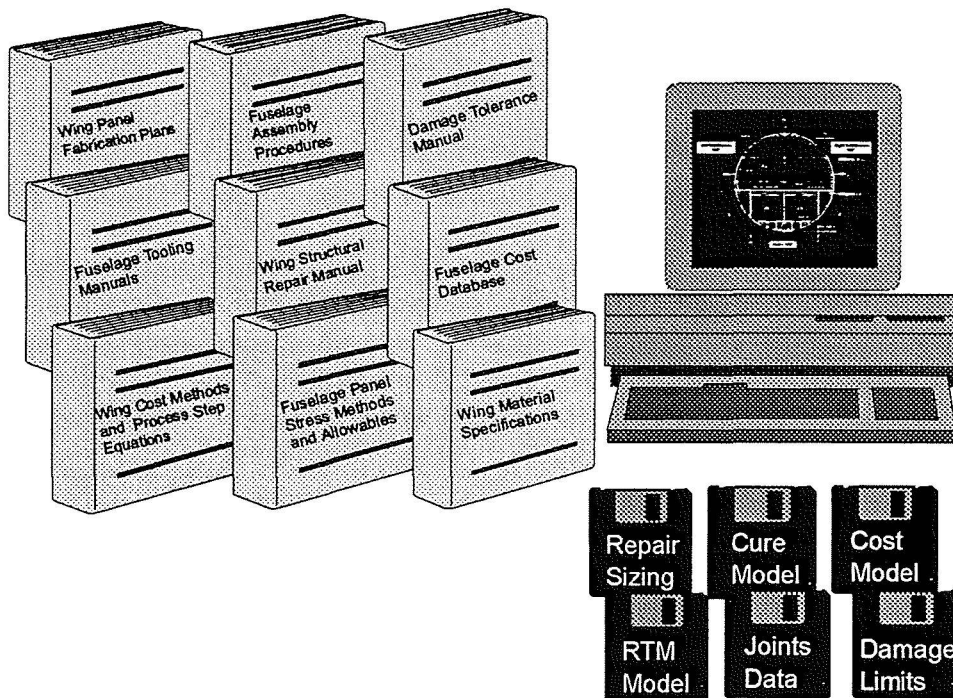

Figure 3-10: Examples of reliable define/build/maintain documentation and software.

3.2.2 Estimated Value of Composite Technology

Composite technology has the potential to improve the value of transport aircraft in a number of ways. Several numerical parameters, of interest to a potential airplane's owner, are available for comparing the value of new technology. Total direct operating cost (Total DOC) provides one of the best quantitative measures of the combined impact of

airplane acquisition costs, weight, fuel efficiency, and reliability. New technology that decreases the Total DOC is attractive to airlines. Figure 3-11 shows typical components of Total DOC for a wide-body commercial airplane. Note that ownership costs are part of the Total DOC which differs from another measure of value, Total Aircraft Related Operating Costs (TAROC), only in the exclusion of indirect costs (e.g., cabin crew, administrative, and landing fees).

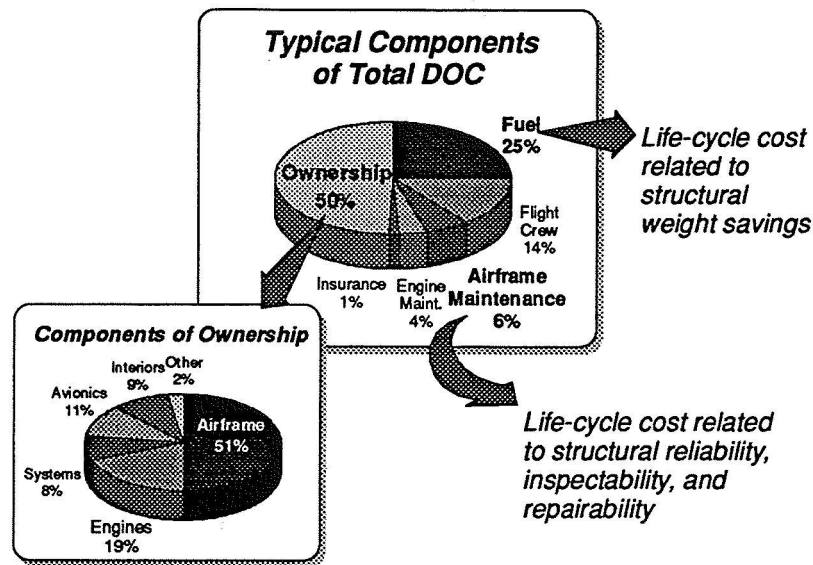

Figure 3-11: Value assessment of new technology.

With fuel prices at their current levels, Figure 3-11 shows that acquisition cost is the largest component of Total DOC. The current economic state of many airlines is such that they are unwilling to pay extra for new technologies, such as composite structures, that have the potential to pay back over time (e.g., reduced fuel costs due to weight savings). Instead, composite structures must provide both near and long term cost advantages. The insert at the bottom of Figure 3-11 shows that the airframe, including wing, fuselage, and empennage structure, represents approximately half the ownership costs.

Note that when composite structures were first introduced, fuel costs were high and represented a greater portion of the Total DOC than that shown in Figure 3-11. Figure 3-12 shows predictions of how total DOC reduces with structural weight savings for the entire airframe. Inserts in the figure show that structures represent the largest component of operating empty weight (OEW). Benefits of structural weight savings increase significantly when considering engines that are scaled to take full advantage of the weight savings. When determining how weight savings for any particular part of the aircraft decreases Total DOC, the total "structural weight savings" must first be calculated before using the graph in Figure 3-12. For example, 20% weight savings in primary wing structure results in a significantly lower number for total structural weight savings.

The graph in Figure 3-13 shows the predicted results of a simple analysis to convert the cost and weight savings potential of composite technology into Total DOC for

empennage, wing, fuselage, and their combination. The ranges which are illustrated represent uncycled (lower limit) and cycled (upper limit) predictions due to the uncycled savings goals for components shown in the table insert. The Total DOC savings potential is dependent on significant savings in both manufacturing cost and structural weight.

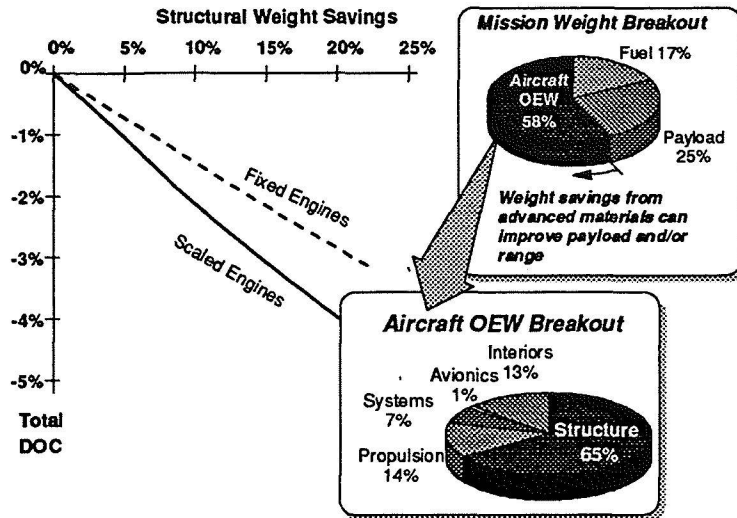

Figure 3-12: Estimates of the value of structural weight savings.

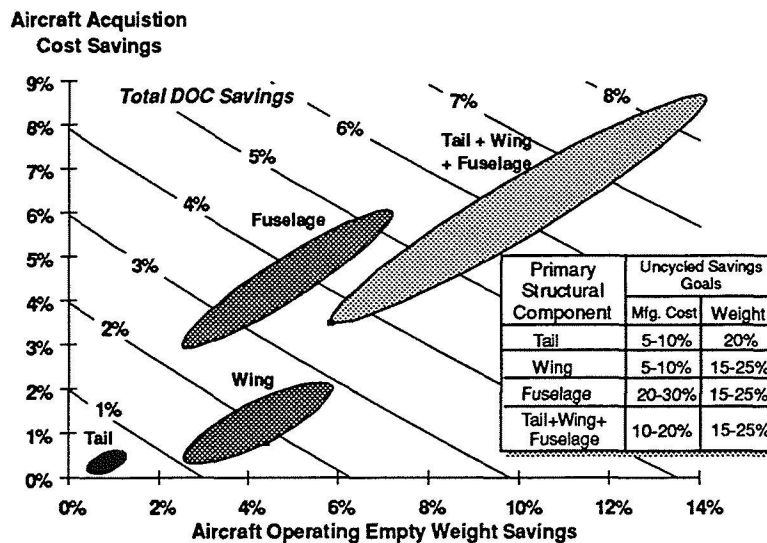

Figure 3-13: Estimates of total DOC improvements possible with composite cost and weight savings goals.

The fuselage cost saving goals shown in Figure 3-13 are significantly higher than those for wing, relating to specific incremental manufacturing improvements identified and the longer timeline until fuselage implementation. A realization of both these issues led to Boeing's desire to develop fuselage technology in the ACT program. Note that 10 to 20% cost or weight savings for any particular structural component result in small percentage changes in the aircraft acquisition costs, OEW, and Total DOC. However, small changes

in Total DOC directly impact airline earnings. Total DOC savings as high as shown in Figure 3-13 would represent advanced aircraft with huge benefits to airlines.

In addition to changes in total DOC for advanced composite structures technology, other economic measures are also important to customers. For example, composite weight savings can increase range and/or payload capacity. Such benefits provide flexibility in transport aircraft use, including the potential for expanded shipping markets. The improved fatigue performance and corrosion resistance of composite structures may also extend the useful life and/or decrease maintenance costs of transport aircraft. Although Total DOC can be used to quantify potential composite maintenance or life benefits, no attempts were made to do so in Figure 3-13.

The commercial aerospace industry is striving to reduce product cycle times (definition, production, and support), yielding affordable and reliable aircraft in time to capture aggressive markets of the future. Increased engineering efficiency is dependent on a strong tie between development and application DBTs. Strategies from the previous subsection also describe Boeing's commitment to capture the advanced technologies in forms suitable for rapid response to production needs.

Figure 3-14 shows the benefits of reduced product development cycle times, assuming the same non-recurring program costs but early entry into service. Note that this "cost of money" benefit can help reduce costs for either the manufacturer, user, or both. Potential Total DOC savings shown in the chart assume all of the savings achieved are passed on to the customers. A 12 month reduction in cycle time yields a benefit similar to that possible from composite wing technologies shown in Figure 3-14.

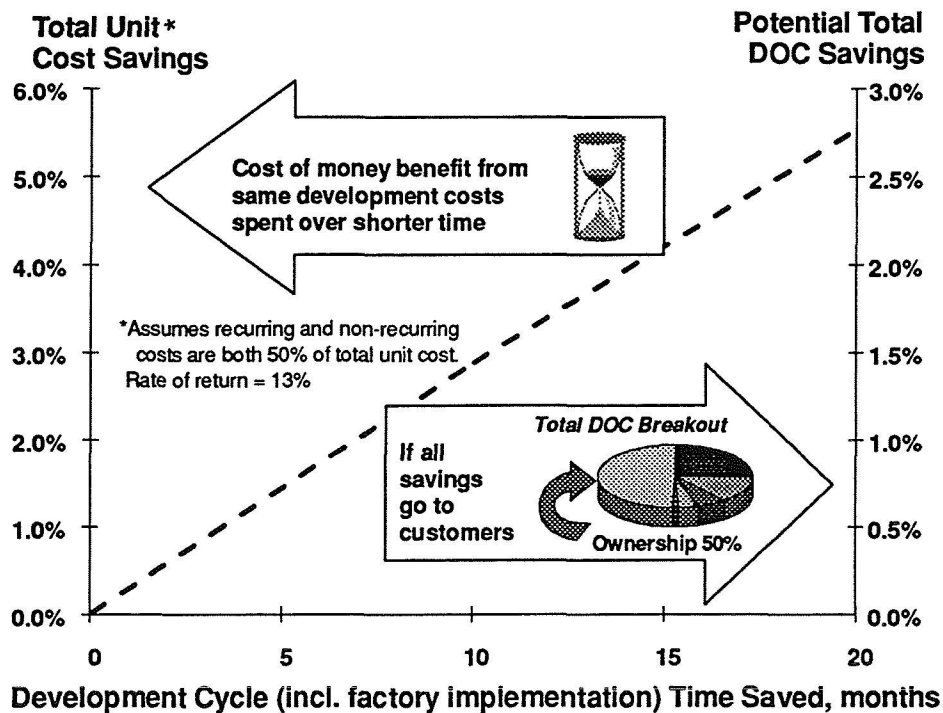

Figure 3-14: Estimated value of reduced cycle time to market.

4.0 ATCAS PROGRAM SCOPE

The primary objective of ATCAS has been *to develop an integrated technology and demonstrate a confidence level that permits the cost- and weight-effective use of advanced composite materials in primary structures of future aircraft with the emphasis on pressurized fuselages*. This objective is consistent with Boeing's strategies for the development of advanced composite technologies for transport aircraft structure.

Work performed in Phases A and B of the ATCAS program relate to all of the first stage (concept select) and part of the second stage (concept development) used to monitor technology readiness (see Figure 3-9).

The ATCAS program cost and weight goals, including aircraft resizing, are:

- 1.) 20 to 25% reduction in acquisition costs, and
- 2.) 30 to 50% reduction in structural weight.

These goals are expressed relative to state-of-the-art aluminum technology. Note that aircraft resizing for the weight saved yields both cost and weight benefits.

4.1 Baseline Fuselage Section

Figure 4-1 shows the baseline fuselage section used for ATCAS studies. It has a constant diameter of just over 20 feet, and a length of 33 feet. This section is immediately aft of the main landing gear wheel-well and is representative of Section 46 on a current widebody Boeing airplane.

Section 46 was selected because it contains many of the structural complexities and manufacturing issues found throughout the fuselage while avoiding higher program tooling costs associated with non-constant cross-sections. It contains window belts, cutouts for passenger doors and a large cargo door, passenger and cargo floors with stanchions, and very high keel beam loads introduced at the forward end of the belly. In addition, this section has high loads in the forward end that diminish to much lower loads in the aft end, allowing transition to minimum gage structure. Therefore, structural scale-up of the baseline section requires consideration of a wide range of critical design criteria and load cases, such that the resulting technology is applicable to other areas of the fuselage.

Also shown in Figure 4-1 are the four panel assemblies, called quadrants, comprising the ATCAS baseline barrel segment at the end of Phases A and B. Top, side, and bottom quadrants have been referred to as crown, side, and keel panels, respectively. The baseline crown is a stringer-stiffened skin concept, while both keel and side quadrants are sandwich panels. The keel quadrant is a panelized concept that transitions from a thick laminate (in the forward end) to sandwich construction (in the aft end). Due to resource limitations, ATCAS studies have assumed similar left and right side quadrants, eliminating the right side cargo door. However, many issues associated with the cutout reinforcement structure for the cargo door are addressed through passenger door cutout reinforcement developments.

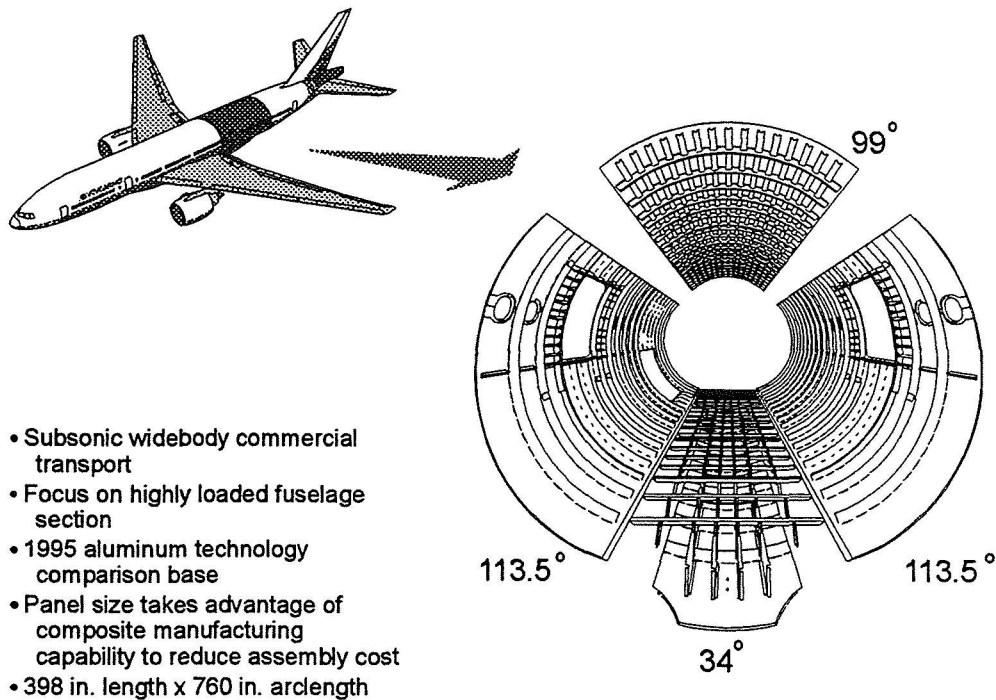

Figure 4-1: ATCAS fuselage barrel and quadrant definitions.

Some changes in the size of the ATCAS quadrants have occurred during the course of the program. For example, the original crown quadrant defined by a DBT chartered to select baseline concepts in 1990 (ref. 3) was smaller (i.e., 90°) than that shown in Figure 4-1. The crown's arc length was increased, based on the recommendations of a special DBT assembled in 1992, helping to reduce the size of each side quadrant. Additional recommended changes in the quadrant sizes prior to future developments that include full-scale demonstrations (e.g., increasing the keel quadrant arc length) will be discussed in Section 6.5.

The quadrant arrangement reduces the number of longitudinal splices from ten (typical of metal aircraft) to four. The only quadrant in Figure 4-1 comparable in size to a typical metal fuselage panel is the 34° keel. The metal fuselage is constrained to ten panels due to size limitations in rolling highly polished aluminum skins. However, automated riveting is used to reduce longitudinal splice assembly costs, and the rivets themselves cost pennies.

Large quadrant skin panels were selected for ATCAS to reduce panel assembly costs and leverage the size-related efficiencies of the automated fiber placement (AFP) process for laminated skins. The baseline section has the advantage of six less longitudinal splices which, for carbon composite structure, require the use of expensive titanium bolts rather than the low-cost aluminum rivets used in metal fuselage. However, the larger composite crown and side panels present significant technical issues, such as the handling and assembly of large, stiff structures. Typically during the assembly of current metal fuselage sections, the skins and stringers are left unfastened for approximately 30 inches at each circumferential splice so that the individual stringers can be "wiggled" for splice alignment. Some payoff also occurs in the assembly of frames at longitudinal splices. Accurate

control of the as-cured dimensional and positional tolerances for large panels with bonded element configurations is required to achieve the cost benefits of the quadrants.

4.2 Fuselage Load Conditions¹

The aft fuselage of a conventional commercial airplane is loaded as a beam by pitch and yaw maneuvers. Pitch maneuvers can induce high axial loads in the crown and keel with high shear in the side panels. Yaw maneuvers can induce high axial loads in the side panels. In addition to these flight induced loads the fuselage is loaded with internal pressure due to the need to maintain cabin conditions of no higher than 8000 feet, even though most commercial aircraft cruise at altitudes of 30,000 to 40,000 feet.

The dominant load cases vary for each area of the fuselage study section. The crown is dominated by pitch-axis body bending load cases that result in peak axial tension and lesser reversed compression. The keel is also dominated by pitch-axis body bending cases that induce high axial compression and lesser reversed tension loads. These load cases are amplified at the forward end due to large cutouts for the landing gear wheel well. Large shear conditions are induced in the transition region between the keel and side quadrants as the concentrated axial loads are redistributed to the lower aft fuselage. The side is critical for shear loading induced from pitch-axis bending as well as axial loading due to yaw-axis bending (e.g., engine-out and rudder maneuvers).

Additional load cases, including those with cabin pressure, are critical to all three fuselage areas in the circumferential direction. These are particularly important with respect to panel damage tolerance, fuselage frames, and longitudinal splice joints. Pressure loads must also be considered applied simultaneously with pitch and yaw maneuvers. Typical maximum operating pressure differential for a wide-body commercial airplane is 8.0-9.0 psi, with an "Ultimate" internal pressure alone case being two factors of the maximum cabin pressure relief valve setting (e.g., $2.0 \times 9.1 = 18.2$ psi).

As discussed above, critical loads for the section 46 crown and keel areas include axial loads, emanating from flight maneuvers, that vary from high at the forward end to relatively low at the aft end. Crown loads are easy to visualize because the only major cutouts that interrupt crown load paths are passenger doors that exist in the side quadrants. As a result, the task of blending structural details in the crown panel is relatively simple in comparison to other quadrants. Figures 4-2 and 4-3 show maximum crown tension and shear loads, respectively. Maximum tension loads gradually diminish moving forward to aft. Crown shear loads are relatively low except adjacent to the passenger door cutout.

The forward end of the keel panel in Section 46 has to redistribute huge axial compression loads related to a critical pitch maneuver. These loads are induced by fuselage cutouts for the center wing box and main gear cavities. In a metal aircraft, discrete keel beam chords

¹ Loads plotted in Figures 4-2 through 4-10 represent "Ultimate" conditions

introduce the high axial loads into Section 46. Axial compression loads typical of the keel beams of current wide-body aluminum airplanes can be as high as 600,000 lb in each of the two chords.

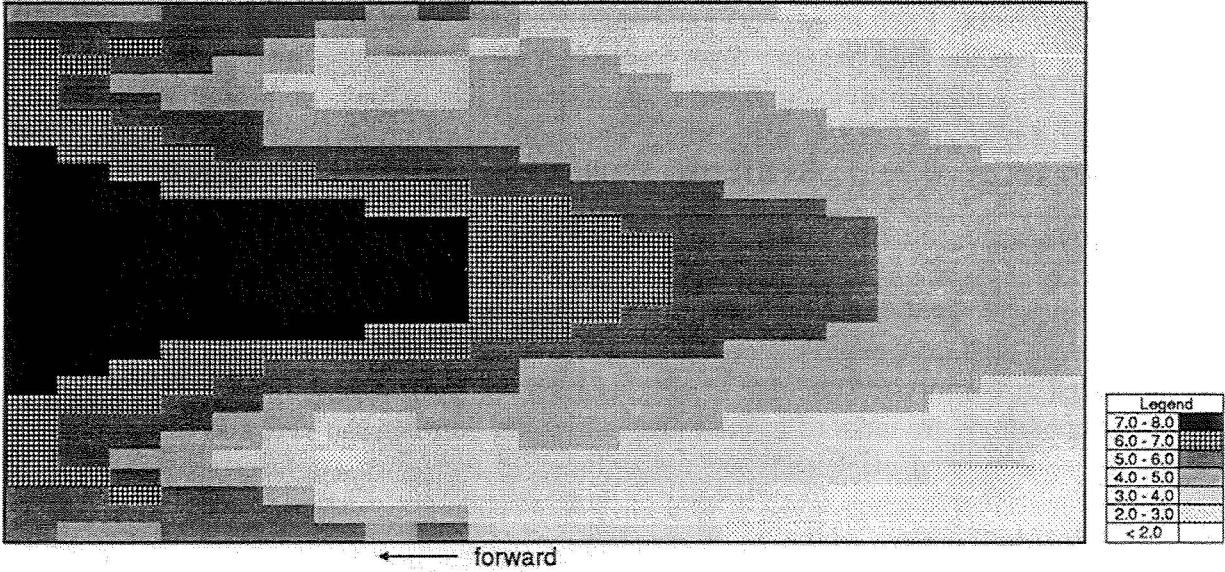

Figure 4-2: *Maximum tension loads (kips/in) in the crown quadrant.*

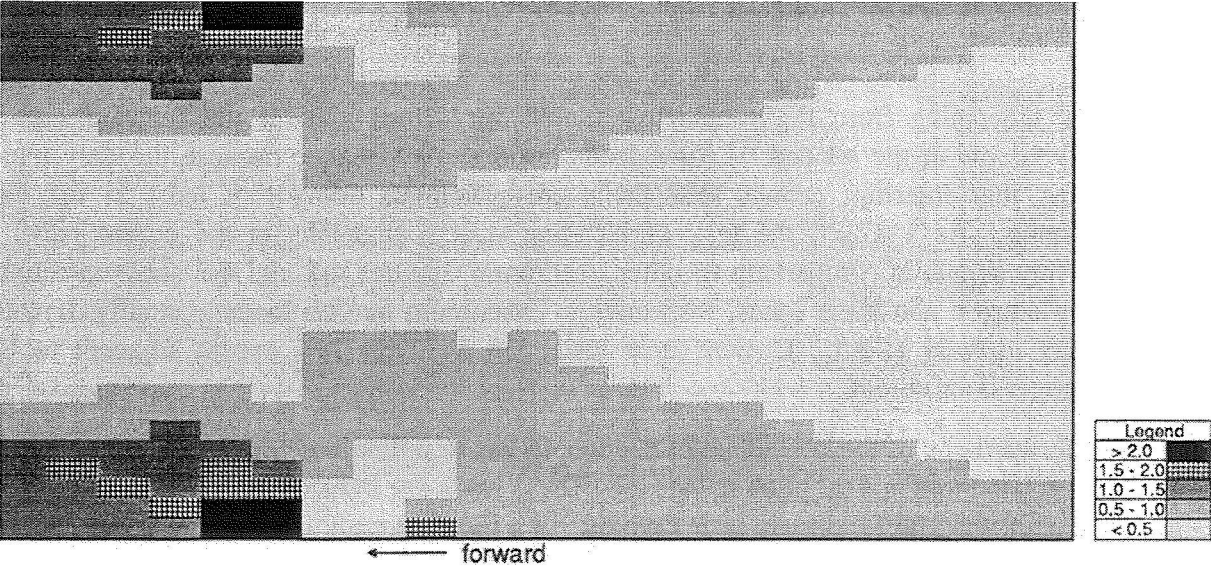

Figure 4-3: *Shear loads (kips/in) associated with maximum tension loads in the crown.*

Figures 4-4 and 4-5 present typical axial and shear load contours for a critical load case in the lower side and keel area of Section 46 in an aluminum fuselage. Loads shown in these figures were summarized from a finite element model (FEM) of the baseline metal fuselage, representing results based on typical aluminum stiffness and cross-sectional areas. The load contours plotted in these figures include only the loads distributed in the skin and stringers, not the loads occurring in the keel chords. Figures 4-4 and 4-5 help to show how the loads are perturbed by passenger door and right-hand side cargo door cutouts, and how the keel chord load redistribution interacts with the cargo door to produce unsymmetric keel and side panel load contours.

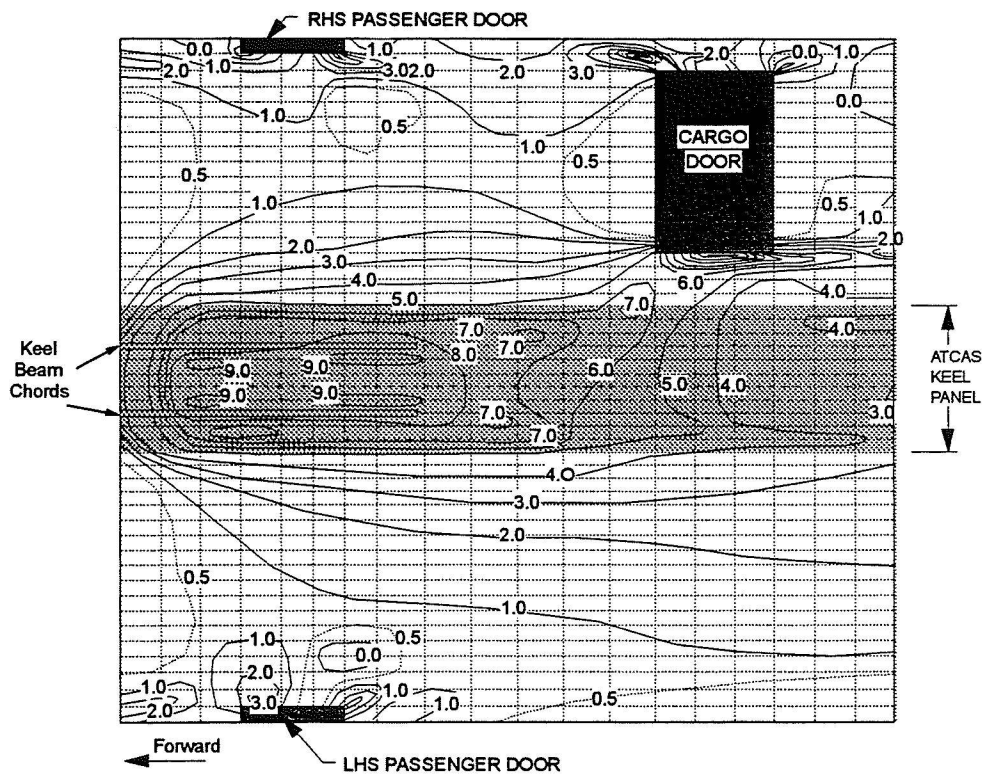

Figure 4-4: *Typical keel and lower side panel axial compression loads (Kips/in) for an aluminum fuselage.*

Figures 4-4 and 4-5 also give a sense of how load redistribution due to cutouts affect the keel and side panel design details. In order to meet airplane weight and mission goals, the structure must be efficiently tailored for the load contours associated with door and wheel well cutouts. For example, on the metal fuselage, the aluminum skin thickness changes from 0.07 inch. in minimum gage areas to 0.50 inch. (including the bear strap reinforcement) at the passenger door cutouts, and up to 0.30 inch. at the forward end of the keel panel, with discrete keel beam chords each having an area of 12.0 in².

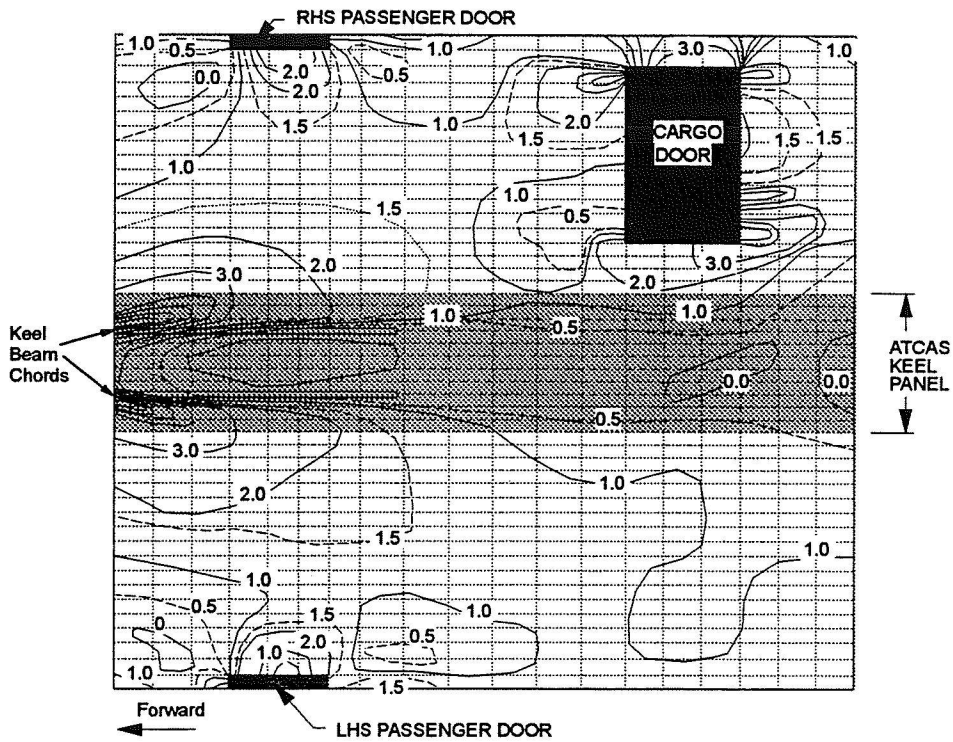

Figure 4-5: Typical keel and lower side panel shear loads (Kips/in) for an aluminum fuselage.

Compression and shear loads for the composite keel quadrant are shown in Figures 4-6 and 4-7, respectively. The ATCAS panelized keel design, first introduced in ref. 4, effectively smears the concentrated loads reacted from discrete chords into a more even distribution in the forward end. As previously mentioned, the rear cargo door cutout was eliminated from the ATCAS Section 46 design. As a result, the aft keel has a more symmetric load distribution than that illustrated in Figures 4-4 and 4-5.

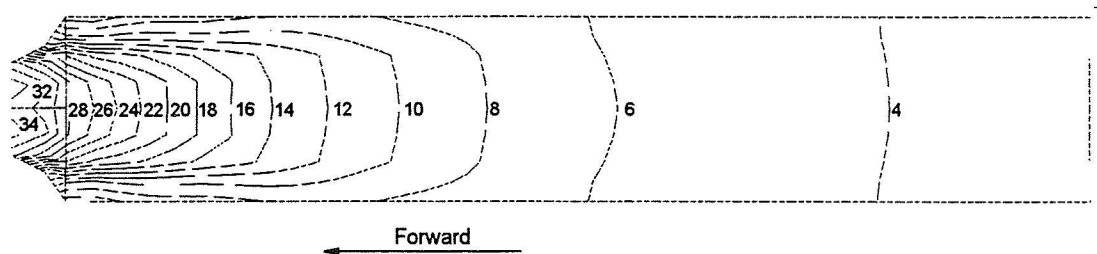

Figure 4-6: Maximum compression loads (Kips/in) in the composite keel quadrant.

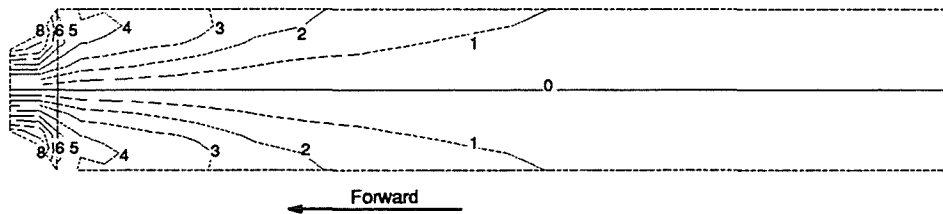

Figure 4-7: *Maximum shear loads (kips/in) in the composite keel quadrant.*

Unlike the crown and keel, the side quadrant is affected by numerous load cases (ref. 5). Critical loads for the side panels include a) shear combined with internal pressure, and b) either tension or compression axial loads combined with internal pressure. Figures 4-8, 4-9, and 4-10 summarize the maximum axial tension, compression, and shear for critical side panel load cases. Redistribution of keel loads are evident at the bottom of these figures. The passenger door is seen to have an effect similar to that predicted by the metal FEM model in Figures 4-4 and 4-5. Note loads induced by the overwing longeron, which is forward and below the door cutout.

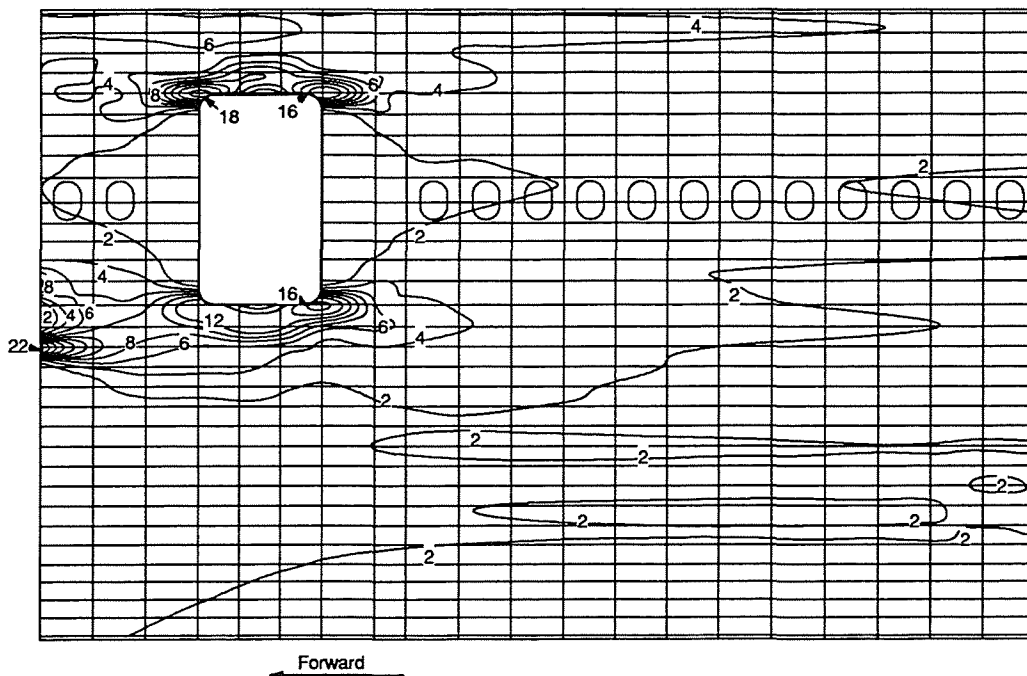

Figure 4-8: *Maximum axial tension loads (kips/in) in the composite side quadrant.*

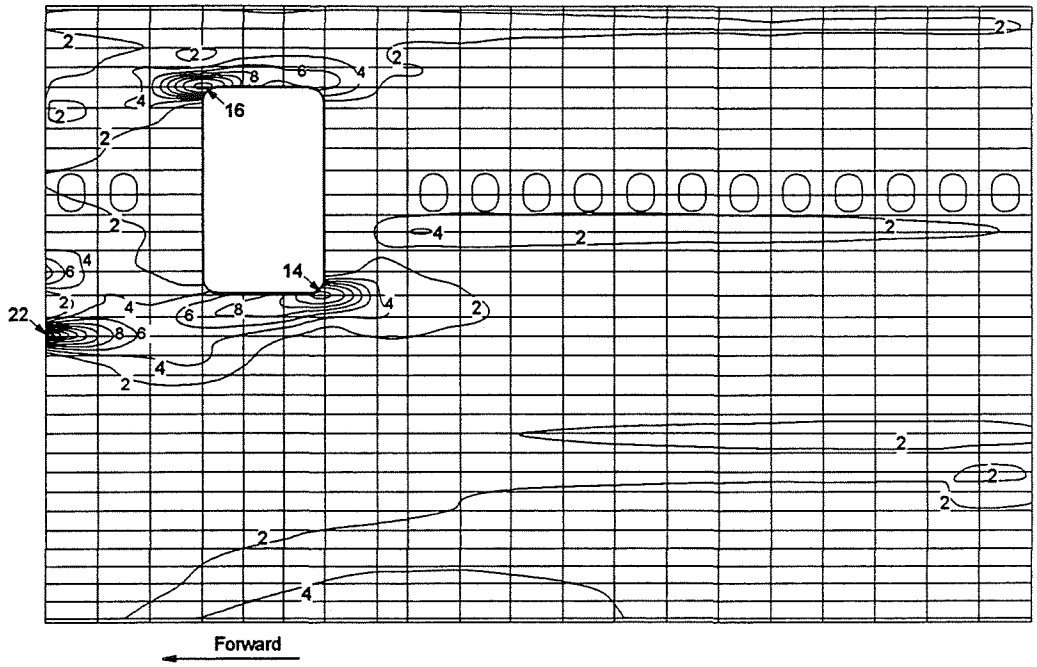

Figure 4-9: Maximum axial compression loads (kips/in) in the composite side quadrant.

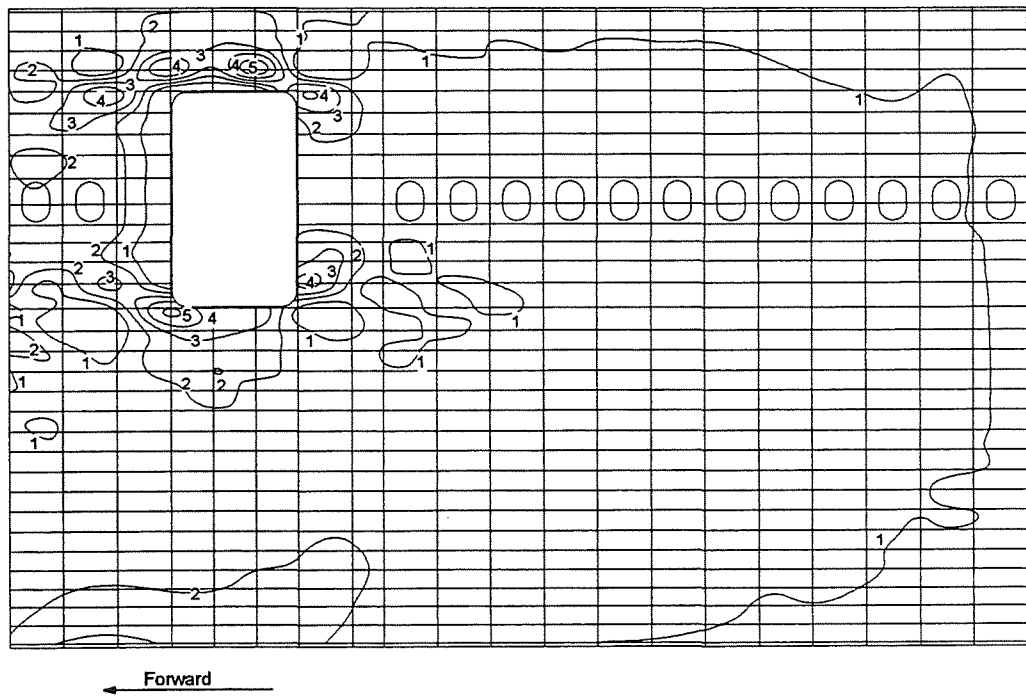

Figure 4-10: Maximum shear loads (kips/in) in the composite side quadrant.

The side panel is also dominated by numerous design details interacting with the overall fuselage loading that exacerbate local load levels. Examples of these are load path discontinuities caused by passenger door cutouts, windows, and major attachments (e.g., over-wing longeron and floor structure). A wide range of load conditions must be considered for the side due to these local details. For instance, ground conditions are critical for some elements of the door reinforcement structure while emergency landing conditions must be considered for the circumferential frames and the passenger and cargo floor support structure.

In order to meet the cost and weight saving goals versus a metal fuselage, ATCAS keel and side quadrants must be efficiently tailored for the major load redistribution associated with door and wheel well cutouts. Additional discussions of the loads used for fuselage design, including a description of the composite FEM internal loads model, can be found in ref. 6.

4.3 Schedule

Timelines for the ATCAS program outlined a critical path for concept selection, and then focused development of the associated technologies. This sequence was followed for each quadrant. Figure 4-11 shows the Phase A/B schedules, including milestones that culminate in the selection of design and manufacturing concepts for each quadrant. Figure 4-12 shows the Phase A/B schedules with milestones for major hardware demonstrations that occurred during the course of the program.

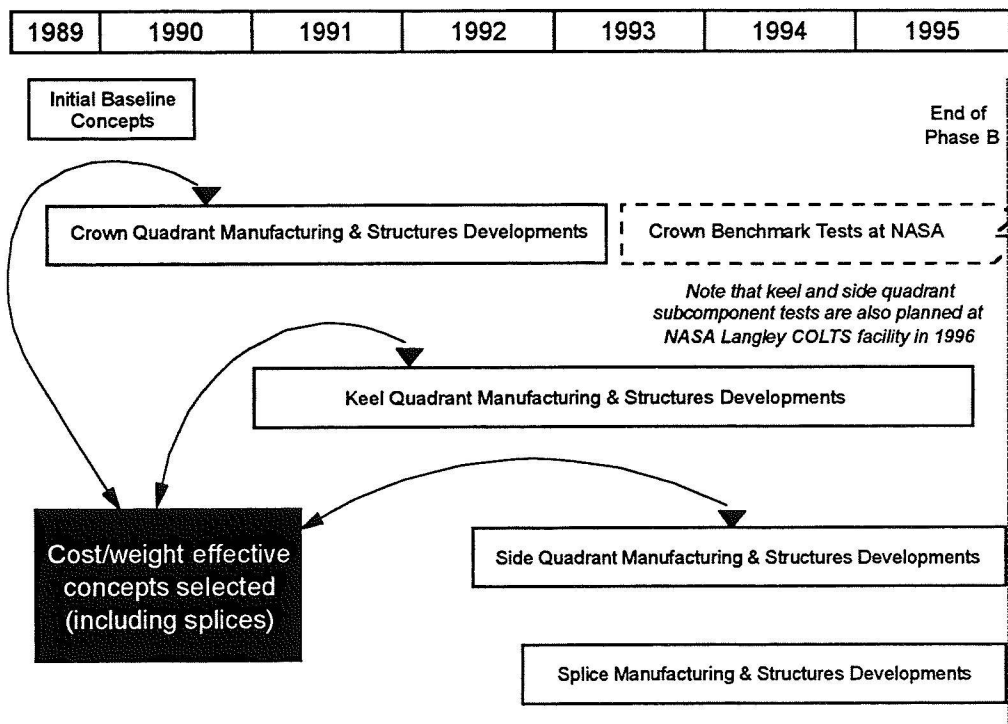

Figure 4-11: Top-level schedule used in Phases A and B, showing milestones for cost and weight trade studies.

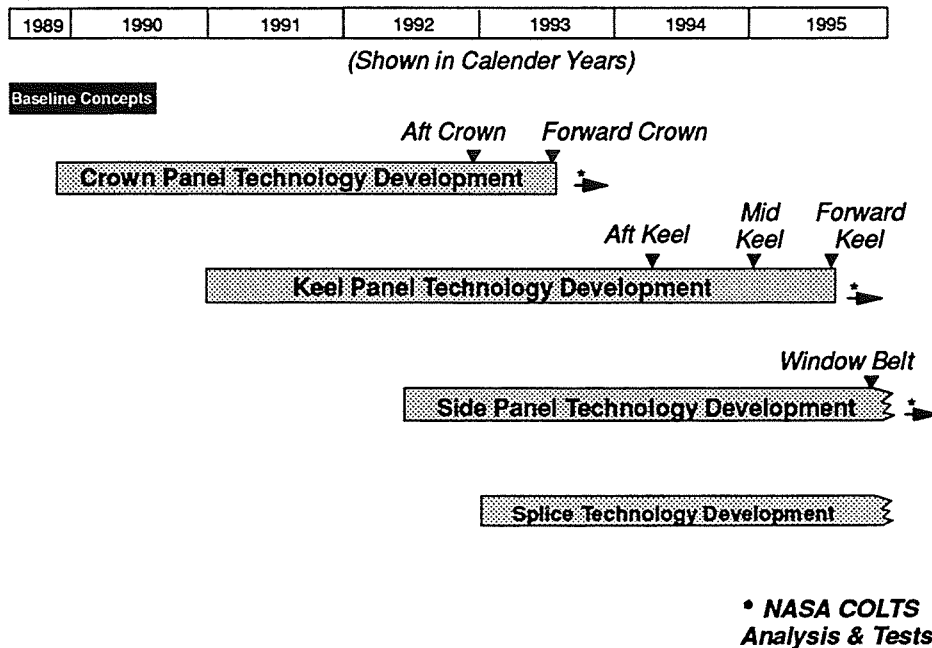

Figure 4-12: Top-level schedule used in Phases A and B, showing milestones for major hardware demonstration.

As shown in Figure 4-11, baseline design and manufacturing concepts were selected for all quadrants in the first year, helping to focus other NASA Advanced Composite Technology (ACT) initiatives. Only the crown concept was subjected to rigorous cost and weight trades in 1990 (see ref. 3). Cost and weight trades resulting in the selection of a sandwich keel quadrant were completed in 1991 and are documented in ref. 4. Side quadrant development was delayed until 1992 due primarily to manpower limitations. A cost and weight trade for the left side quadrant was completed at the start of 1994, resulting in a change in the baseline concept from a stringer-stiffened skin panel to sandwich (ref. 5). Discussions in Section 6 will highlight the importance of sandwich designs and manufacturing processes to achieving ATCAS program cost saving goals.

Major hardware demonstrations were performed for areas of the fuselage section identified in Figure 4-12, each having unique design details and manufacturing challenges. All such demonstrations started with the detailed design and fabrication of curved panels having dimensions on the order of 7 ft. by 10 ft. Loads used for the former were characteristic of that portion of the full-scale quadrant under investigation. Many major hardware demonstrations had multiple purposes. For example, time trials and manufacturing tolerance measurements were crucial to the cost and producibility databases, respectively. Most panels were also used in structural tests performed at Boeing or NASA. In addition, some panels were used for maintenance trials (i.e., aft crown and mid keel panel repair) prior to structural evaluation.

A unique database was generated for each quadrant. Most developments for the baseline crown concept (a hat-stiffened panel with bonded frames) ended in 1993. The large

number of major panels fabricated for the crown addressed the repeatability of advanced manufacturing processes (refs. 7 and 8). Benchmark crown panel tests using a pressure box at Boeing and NASA Langley Research Center have been focussed on damage tolerance. The NASA tests are still in progress. The three classes of sandwich keel hardware demonstrations included: (i) minimum gage aft panels (10 ply facesheets), (ii) a panel for the mid portion with increased facesheet gage (30 plies), and (iii) a panel having ply build-ups representative of the forward keel. Additional evaluations for these panels included stability, damage tolerance, repair, and load redistribution. Finally, side quadrant demonstrations were limited to two windowbelt panels which will be tested under various combined load scenarios.

4.4 Approach

The DBT approach selected for use in ATCAS was initially described in ref. 3. As discussed in ref. 9, this approach has evolved during the program to become more efficient, minimizing the number of meetings needed to direct team activities and make program decisions. Some of the improvements over time can be attributed to maintaining a core ATCAS team with minimum reassignment of members to other activities in their respective companies. Another key to improved efficiency was to empower smaller teams with responsibilities for specific tasks, including control of an allocated portion of the budget and detailed schedules. This was particularly beneficial for those tasks that involved coordination between team members inside and outside Boeing.

Figure 4-13 shows the four steps used for Phase A/B studies in each quadrant. As discussed in greater detail by ref. 10, these steps have proven crucial to the initial development of cost-effective ATCAS technologies with limited production experience. The first step in Figure 4-13 identifies a value-added concept. The second and third steps continually update the fourth, which relates to cost credibility and the associated technology database. The available resources (manpower and budget) and design complexity led to some differences in the timelines and progress achieved for each quadrant. As a result, the relative timelines in Figure 4-13 represent an average of that occurring for the crown, keel, and side quadrant studies.

During the first step, global evaluation, concepts were selected based on cost and weight trade studies for the design and manufacturing space of interest. Representative design detail was considered in global evaluation to establish manufacturing pre-plans and perform a bottoms-up cost estimate. This step of the DBT approach also yielded descriptions of manufacturing and technical issues for the selected concept, helping to focus subsequent development efforts.

The second step, local optimization, marked the start of detailed design development for the selected concept. This step in the approach was supported by process trials and building block tests. Local cost and weight trades included the preliminary use of design tools for structural sizing and cost prediction. This led to the definition of major hardware demonstrations. During local optimization, functional disciplines also integrated their efforts to maximize the results generated per available budget. For example, process

trials were often used for structural tests, yielding building block data and some understanding of the effects of manufacturing "defects".

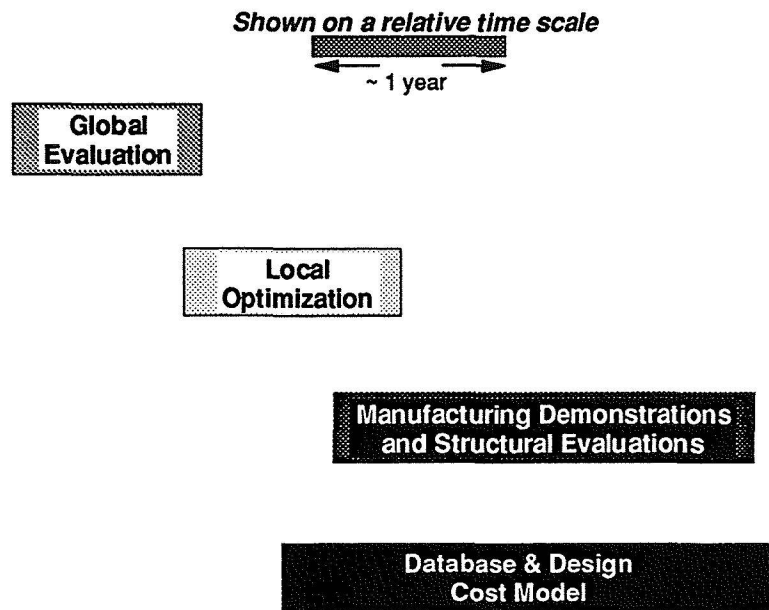

These steps have been applied to crown, keel, and left side quadrants

Figure 4-13: Steps in the ATCAS technical approach.

Figure 4-13 shows that major manufacturing demonstrations and structural evaluations were performed following local optimization. Phase B scaleup resulted in the fabrication of curved subcomponent panels, including stiffeners, frames, and other design features. Milestones shown in Figure 4-12 represent areas of the fuselage chosen for major manufacturing and test evaluations. Manufacturing, structures, and maintenance studies performed in ATCAS always included correlation with supporting analyses to help update technology tools that represent the database.

The final step in the ATCAS approach shown in Figure 4-13 ran parallel to major manufacturing and test evaluations. It was used to capture the database for the design and manufacturing space that was explored. This included updates to the design cost model or other pertinent technology tools that document recommended design, manufacturing, or maintenance practices. In cases where additional concept development is needed (e.g., side quadrant), documented results include a better definition of problems that require more work and/or plans for further scaleup activities.

All technology tools developed as part of the fourth step in the ATCAS approach will be used for the next stage of composite fuselage development, including the definition of large scale hardware demonstrations and other sections of the fuselage barrel. Subsequent steps, similar to the last three in Figure 4-13, are also envisioned as cycles that update the database in preparation for production applications (see ref. 10).

5.0 QUADRANT CONCEPT DEVELOPMENT

As discussed in the previous section, global evaluation activities resulted in the choice of a skin/stringer configuration for the crown, and sandwich construction for the keel and side quadrants [refs. 3-5]. The evaluation process was initiated first for the crown, then the keel, and finally the side quadrant. The relative maturity of the databases supporting each quadrant's development is similarly staggered. As a result, insights on the ATCAS crown concept are more extensive than those for the keel, which are more than those for the side. However, the keel and side databases are complementary since both involve sandwich design concepts.

This section starts with a synopsis of crown, keel, and side quadrant evolution. The configuration considered baseline at the end of Phase B will be highlighted for each quadrant. A more complete description of representative design details for each quadrant can be found in other ATCAS reports (refs 3 - 5, 33). Longitudinal and circumferential splice concepts are also presented, although detailed design has been limited by a lack of manufacturing and structural scale-up in this area during Phases A and B. Finally, critical technical issues for the ATCAS fuselage barrel are summarized in Section 5.5 as a prelude to discussions on cost assessments and technical progress in Sections 6 and 7.

5.1 Crown Design and Manufacturing Processes

The crown panel design is depicted in Figure 5-1. The stiffened skin design features cocured longitudinal hat-section (closed) stringers and cobonded J-section circumferential frames. The stringer spacing, which ranged from 12 to 17 inches during different stages of concept development, is 14 inches in Figure 5-1. The frames, spaced nominally at 21 inches, contain cutouts (referred to as mouseholes) to permit continuous stringers. The mouseholes necessitate flanges on the frames to ensure bending-stiffness continuity across the frame-stringer intersection. A discussion of the critical margins of safety for the baseline crown design shown in Figure 5-1 is presented in ref. 6.

The baseline manufacturing approach for crown panels involves AFP of skin charges on a convex mandrel. The stringer charges are fabricated using automated tape layup, and are then hot drape formed into a female tool using elastomeric mandrels. The skin and stringers are cocured on a hard outer-mold-line (OML) tool with semi-rigid inner-mold-line (IML) cauls. Braided/resin-transfer-molded (RTM) frames are cobonded to the skin during the same cure. Additional details on manufacturing methods can be found in ref. 8.

Skin, stringers, and frames used a standard modulus carbon fiber (Hercules AS4) in untoughened epoxy matrices. This selection was based on cost and weight trades that suggested that more expensive fiber types were not worth the weight savings possible in crown quadrant applications. The matrix used for the frame RTM process (Shell RSL 1895) was different than that used in skin and stringers (Fiberite 938). Additional details on the materials and processes can be found in ref. 11.

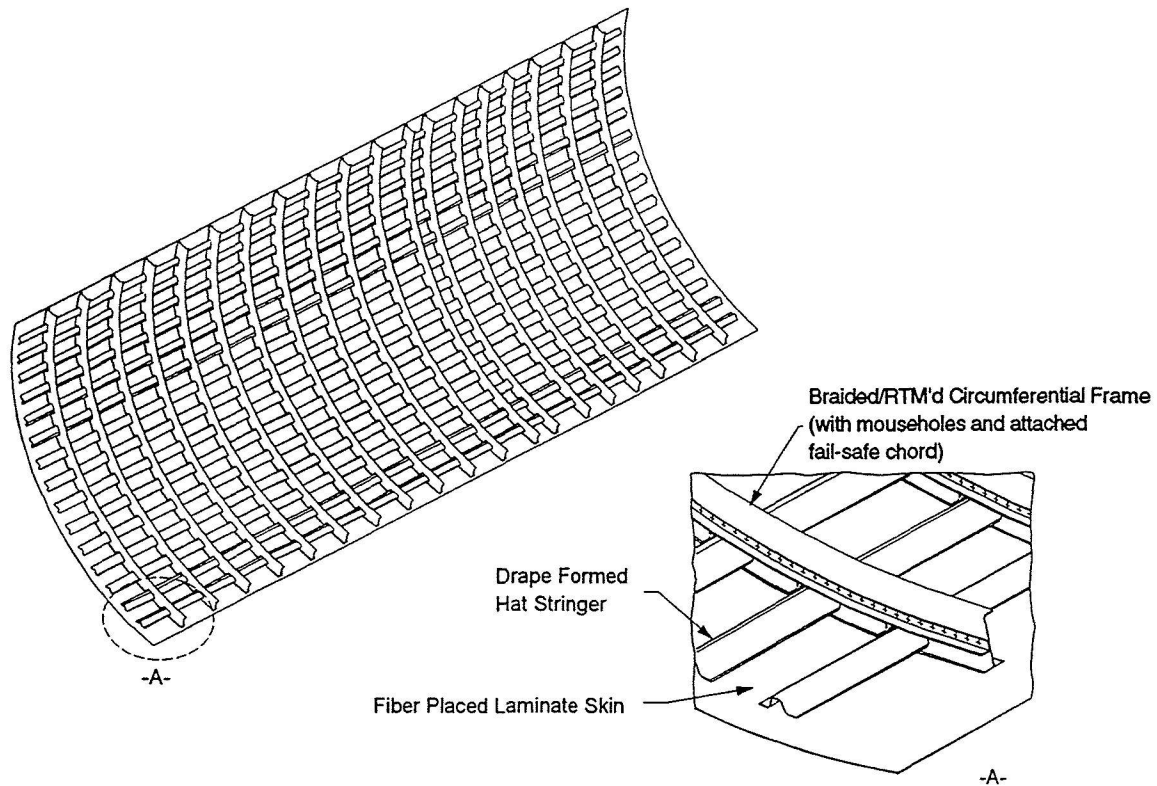

Figure 5-1. Baseline crown panel configuration.

Design development of the crown concept selected in global evaluation started at the end of 1990. This was the first attempt to apply local optimization. In 1991, detailed design, building block tests, and process trials were performed to optimize the crown panel structure. During this time, a software tool for design cost modeling and structural analysis was developed to support cost and weight trade studies (ref. 12). The most critical design detail affecting cost in these studies was stringer spacing, due to its impact on numerous process steps. Near the end of 1991, an ACT initiative was established to enhance the software tool supporting design. As a contract modification to the ATCAS program, this initiative became known as Cost Optimization Software for Transport Aircraft Design Evaluation, COSTADE, (ref. 13-15).

The first crown design developed in local optimization utilized relatively soft skin and hard stringer layups (as related to laminate modulus in the quadrant axial direction). This design minimized both cost and weight and was damage tolerant but proved to be difficult to fabricate, causing warpage and tool entrapment problems in the initial crown manufacturing scale-up (ref. 9). Subsequent crown concept development using COSTADE evaluated a design that had improved producibility, while expanding the quadrant size from a 90°- to a 99°-segment (ref. 16). The resulting design had skin and stringer layups with stiffnesses that were more closely matched than that developed initially.

Near the end of ATCAS Phase A and B crown studies, additional COSTADE runs were performed using updated design criteria and the database generated through May, 1993 (ref. 17). Results from these studies confirmed the selection of crown materials and led to further potential improvements in skin and stringer layups, increasing the axial stiffness of both. The benefit of this crown design variation was that it improved producibility, repairability, and bonded frame integrity, while meeting more stringent axial damage tolerance criteria. The only reservation of this crown design variation was that the increased axial stiffness required additional fuselage analysis, tending to increase the crown loads while decreasing keel loads (ref. 18). However, such a shift in the loads may also be desirable, considering that composite structures are generally more efficient under tension than compression.

As mentioned in the previous paragraphs, early crown designs did not balance manufacturing, maintenance, and structural performance, while optimizing for cost and weight. The ability to balance all of the important design characteristics is directly related to the corresponding database. The advanced processes and innovative designs selected by ATCAS, in pursuit of aggressive cost and weight-savings goals, required sufficient data generation to isolate the key design and process drivers. For example, the original damage tolerance criteria, residual strength database, and related analysis methods for axial and hoop load cases were incomplete, leading to skin and stringer layups optimized for pressure damage containment. As a result, the axially soft skin layup (as compared to the stiffness in the hoop direction) had lower axial damage tolerance and was very difficult to repair. Bearing/bypass issues for the bolted repair led to a complex design with an inordinate number of fasteners.

Since the crown represented the first quadrant pursued by ATCAS, it also helped define the approach described in Section 4.3. Figure 5-2 shows the concept development steps applied to each quadrant. Initially, it was felt that the database generated during local optimization would provide the necessary insights to establish final design definition for manufacturing and structural evaluations. Experiences from the crown improved the ATCAS approach, primarily through the realization that subscale data available during local optimization was not sufficient to complete detailed evaluation. In addition, maintenance developments for the crown did not begin until after local optimization was completed. In subsequent studies, maintenance was given earlier attention. As shown in Figure 5-2, local optimization evolved to become the development step that provided the initial database and a design starting point for larger hardware evaluations.

Crown studies also indicated that the main purpose of manufacturing demonstrations and structural evaluations (middle step in Figure 5-2) was to update the technology database (final step in Figure 5-2). Such technology includes reliable define/build/maintain documentation and software discussed in Section 3.2.1. It was determined that larger manufacturing scale-up and demonstration articles were crucial to ensuring (1) fabrication developments leading to accurate process step definition, (2) design producibility, and (3) consideration of typical manufacturing variations and process-induced performance traits in structural assessments. As a result, overall concept development became dependent on the studies performed with sufficient subcomponent panel sizes.

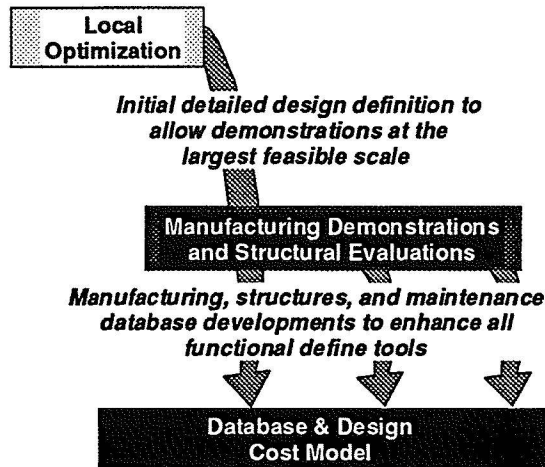

Figure 5-2: Second, third, and fourth steps in the ATCAS approach.

Figure 5-3 shows the relative size difference between panels manufactured in Phases A and B versus the full-scale quadrant panels. Initial cure trials performed for local optimization used panel sizes less than or equal to the 3 ft. by 5 ft. curved panels shown in the figure. While these small panels yielded some useful information on the cure cycle and tooling details at stiffener and frame intersections, they were not large enough to provide the necessary information on manufacturing processes and tolerances. The ATCAS DBT selected larger 7 ft. by 10 ft. curved panels for the middle step in Figure 5-2. This size appears to be sufficient for determining if selected design concepts and processes have potential cost savings at the quadrant scale.

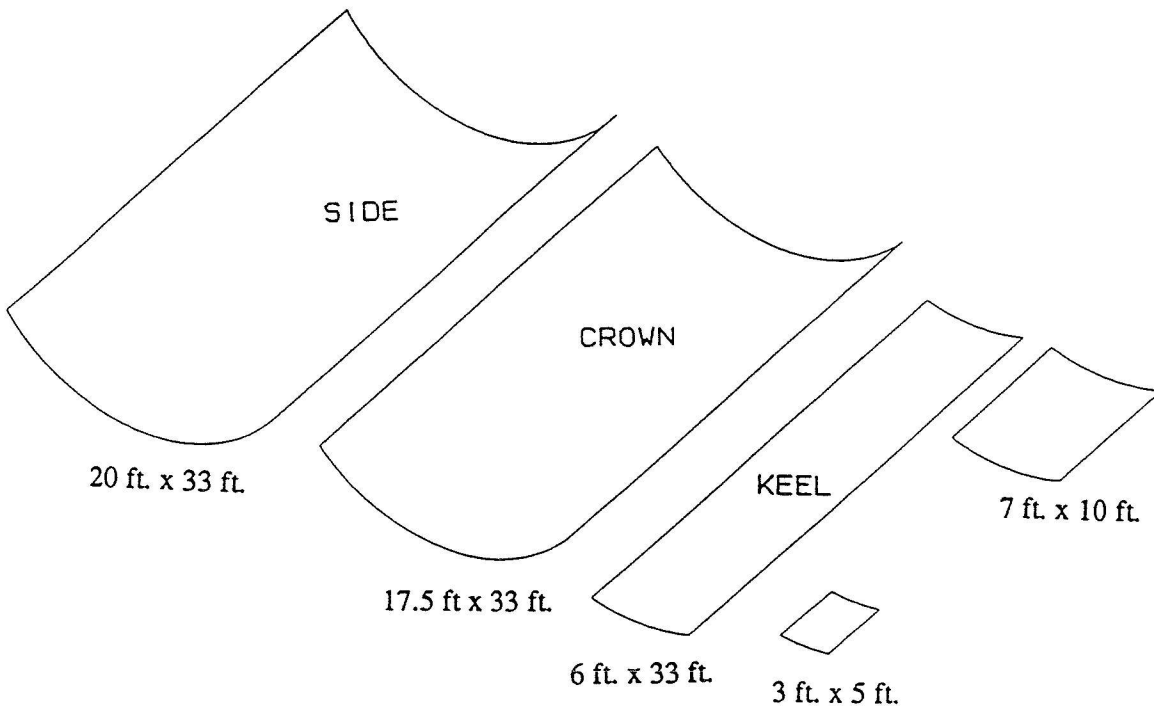

Figure 5-3: Large panel manufacturing demonstration.

Development of the ATCAS crown concept ended in 1993. Subsequent tests at NASA Langley have continued to evaluate structural performance. The primary crown design detail still in question at the end of Phase B relates to the use of a bonded frame with mouseholes that have no attachment to the hat stringers (see insert in Figure 5-1). Structural performance (e.g., discrete source damage arrestment) and reliability issues for this detail are discussed in ref. 6. Section 6.2 addresses cost and weight implications of a change to mechanically fastened frames. Note that some of the benchmark crown subcomponent panels fabricated and tested in ATCAS also evaluated a bolted frame design variation (ref. 6 and 7).

5.2 Keel Design and Manufacturing Processes

The keel panel design (Figure 5-4) utilizes a thick laminate to redistribute the high compressive keel chord loads at the forward end. The design transitions to sandwich construction as the loads redistribute towards the sides and diminish further aft. The thick laminate acts as a panelized keel chord by distributing the equivalent material of discrete keel chords (typical of conventional fuselage structure) across a wider panel area. This structure reacts a 1.4 million pound compression load induced by cavities in the fuselage shell (i.e., center wing box and landing gear wheel well), located forward of Section 46. Ply drops and core tapers are balanced such that a constant panel thickness — and therefore constant inner panel radius — is maintained to maximize frame commonality, thereby reducing fabrication tooling costs (ref. 10). Discussions on critical margins of safety for the baseline keel design shown in Figure 5-4 are presented in ref. 6.

Sandwich panel edges incorporate full-depth close-outs (rather than ramped-down edges) to simplify the frame contour interface, increase the edge bending stiffness, and provide the necessary structure for splice joint attachment. With this full-depth panel edge, the close-outs must protect the core from moisture ingress. The circumferential frames are cobonded constant J-sections. Longitudinal intercostals are required in the forward frame bays to stabilize the panel in the area of highest compression load. The attached cargo floor structure consists of discrete precured, pultruded floor beams and stanchions which are mechanically fastened to the frames.

The keel panel manufacturing approach is similar to that of the crown in the use of AFP, braided/RTM frames, OML cure tooling, and semi-rigid IML cauls. Additionally, individual honeycomb core pieces must be rough machined, heat formed to curvature, spliced together with the precured close-outs into a core blanket, and final machined prior to panel cure. The precured frames and intercostal attachment chord elements are cobonded to the sandwich panel. The intercostals are mechanically fastened to the attachment chords and cargo floor stanchions. Additional details on the manufacturing methods can be found in ref. 8.

Keel sandwich skins, frames, intercostals, floor beams, stanchions, and edge close-outs all used a standard modulus carbon fiber (AS4). This selection was based on cost and weight trades that suggested more expensive fiber types were not worth the weight savings possible in keel quadrant applications. The skins used a moderately toughened epoxy

matrix (Hercules' 8552) to balance desirable manufacturing properties with impact damage resistance, hot/wet strength, and notch sensitivity. This differed from the matrix selected for the crown, based on keel design drivers. The matrix used for the frame RTM process (3M's PR-500) was also different than that used in crown development (RSL 1895). The latter was not available at the time of keel studies. Note that Lockheed was responsible for the design and development of keel frames under their ACT contract (NAS1-18888). The keel honeycomb core material was Hexcel's HRP-3/16, changing in density from 12 lb/ft³ to 8 lb/ft³ moving from forward to aft portions of the panel. Additional details on the keel materials and processes can be found in ref. 11.

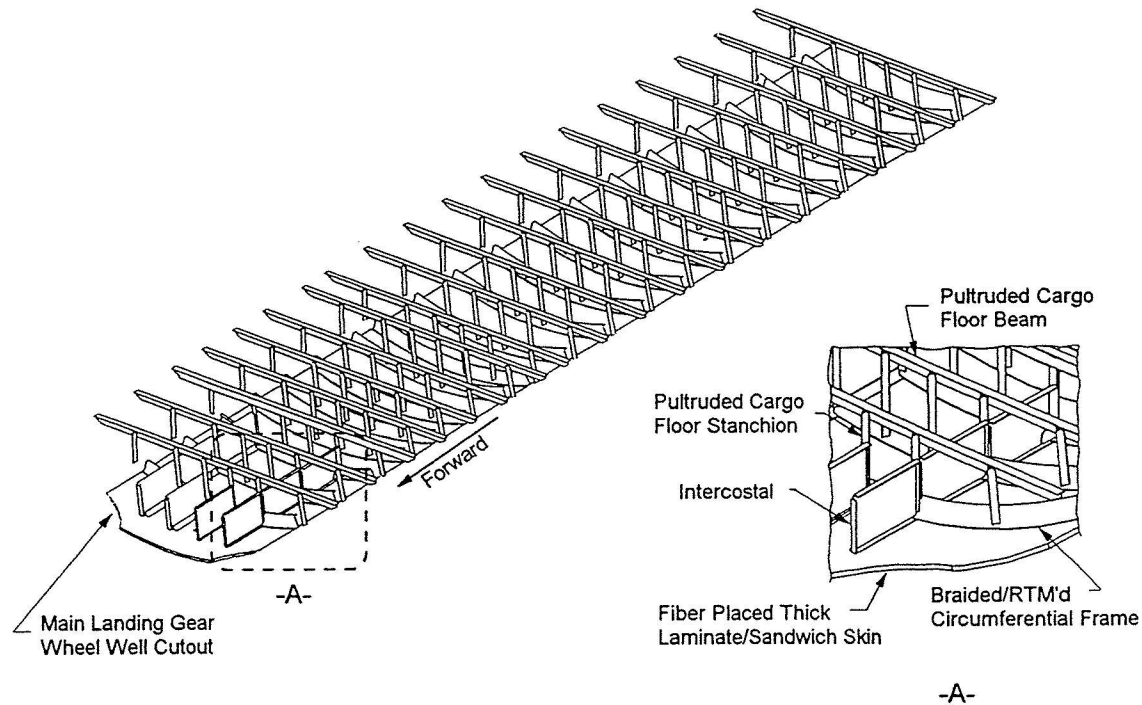

Figure 5-4. Baseline keel panel configuration.

Local optimization of the keel quadrant started in 1992. Most of keel concept development performed through 1994 concentrated on updating the skin panel design (ref. 19). A plan view of the panel bond assembly in Figure 5-5 shows the transitions from a solid laminate to a sandwich panel. As mentioned before, this transition is constrained such that a constant panel gage is maintained. This helps to eliminate part count and, hence, reduce cost. The design cost tool, COSTADE, was used to explore design options within the constant panel height constraint (ref. 20). More detailed analyses, including finite elements, were also performed for the forward keel to address stability, load redistribution, stress concentrations (tabouts and intercostal attachments), and the circumferential splice (see Section 7.3). A keel sandwich panel design, with the facesheet moduli shown in Figure 5-5, was selected based on the combined results of COSTADE and detailed analyses. This design underwent a detailed design review with Boeing fuselage and composites experts in the fall of 1994.

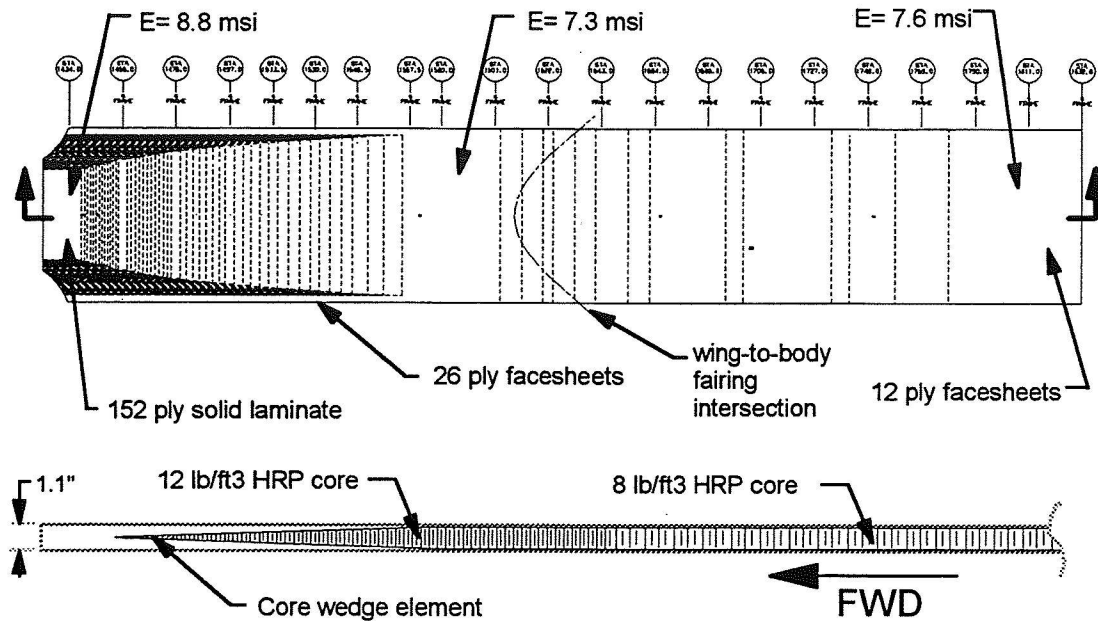

Figure 5-5: Keel Panel Design Details

The first focus of manufacturing scale-up and structural evaluation was on minimum gage structure typical of the aft keel (1993). This was followed by work involving the mid keel (1994), and finally, the forward panel details (1995). The initial aft panel design ramped the edges from sandwich to laminate at longitudinal splices. This design feature was eliminated after initial studies identified manufacturing (ref. 21) and structural issues. Two improved keel to side longitudinal splice design concepts are illustrated in Section 5.4. Mid keel studies culminated with the fabrication of a large panel having 30-ply facesheets, which was used for bonded repair trials and a structural compression test. Significant efforts were applied in 1994 and 1995 to develop a cure cycle suitable for both thick laminate and sandwich portions of the keel design (ref. 22). A load redistribution panel was designed and fabricated for the forward keel to address AFP, core blanket fabrication, panel bond, and load path analysis issues. Sections 7.1 and 7.3 will continue discussions of the ATCAS keel manufacturing and structural studies. Refs. 6 and 8 also provide greater details on these subjects.

Keel quadrant studies included examination of sandwich panel close-out designs, fabrication processes, and bolted joint performance. Close-outs replaced honeycomb core material at sandwich panel edges where an improved barrier to moisture ingress and enhanced structural performance were required. Various concepts traded the ease of fabrication, weight savings, structural performance, and durability. Ref. 11 provides a summary of the results of some keel close-out elements (both longitudinal and circumferential splice concepts) that were built and tested. Some of the manufacturing demonstration panels described in the previous paragraph included candidate close-out designs and processes. Future efforts are needed in this area to optimize the design details and processes.

After Phase B keel concept development was completed, compression damage tolerance was found to depend on facesheet thickness. Residual strength test results indicated significant material property improvements for sandwich panels with thick laminated facesheets (versus those assumed in design, which were derived from test data for sandwich panels with thin facesheets). Referring back to Section 5.1, the final crown design variation (increased axial stiffness) would decrease keel loads. The combined effect of improved compression residual strength properties and lower keel loads will reduce the gage of the solid laminate in the front end of the keel. This will, in turn, allow the panel gage over the rest of the keel to also reduce (i.e., overall keel panel thickness is determined by design drivers in the forward end)

Another design issue given some attention during keel concept development was provisions for penetrations and external attachments associated with airplane systems. These are fairly common in the forward half of the keel, where the panel is covered by the wing-to-body fairing. There are bilge drain holes all along the length of the keel. There are also systems elements such as the VHF antenna shown in Figure 5-6. The metal structure contains a number of intercostals and clips to provide support for this antenna. One ATCAS concept entails embedding a triaxially braided composite tube in the keel panel that can accommodate fastener clamp-up loads and also provide reinforcement for the antenna.

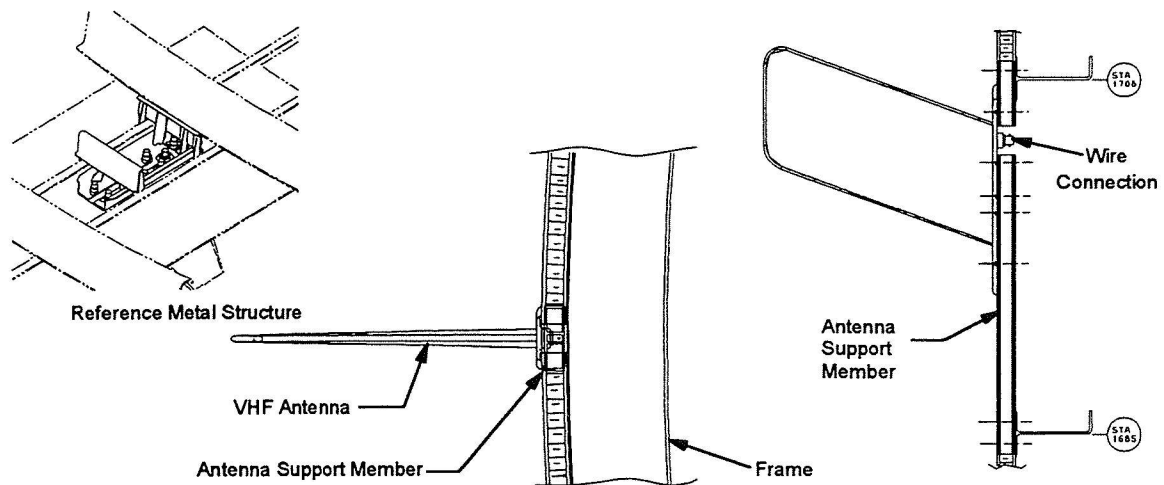

Figure 5-6: Keel design details - antenna support structure

5.3 Side Design and Manufacturing Processes

The side panel design is shown in Figure 5-7. Most of the basic side skin-panel design features, materials, and manufacturing approach are similar to the keel panel. Additional full-depth close-outs are included at the window cutouts. The window and door reinforcement elements are precured and mechanically fastened to the skin panel, with the exception of the passenger-door auxiliary frames, which are cobonded during panel cure. The passenger floor structural elements are precured (pultruded or drape formed) and

mechanically fastened upon fuselage-section assembly. Discussions on critical margins of safety for the baseline side design shown in Figure 5-7 are presented in ref. 6. The focus of Phase B side manufacturing developments were on window-belt structure. Complementary efforts by Lockheed developed an alternate window-belt concept, involving ramped core details and IML tooling (NAS1-18888, refs. 23-26).

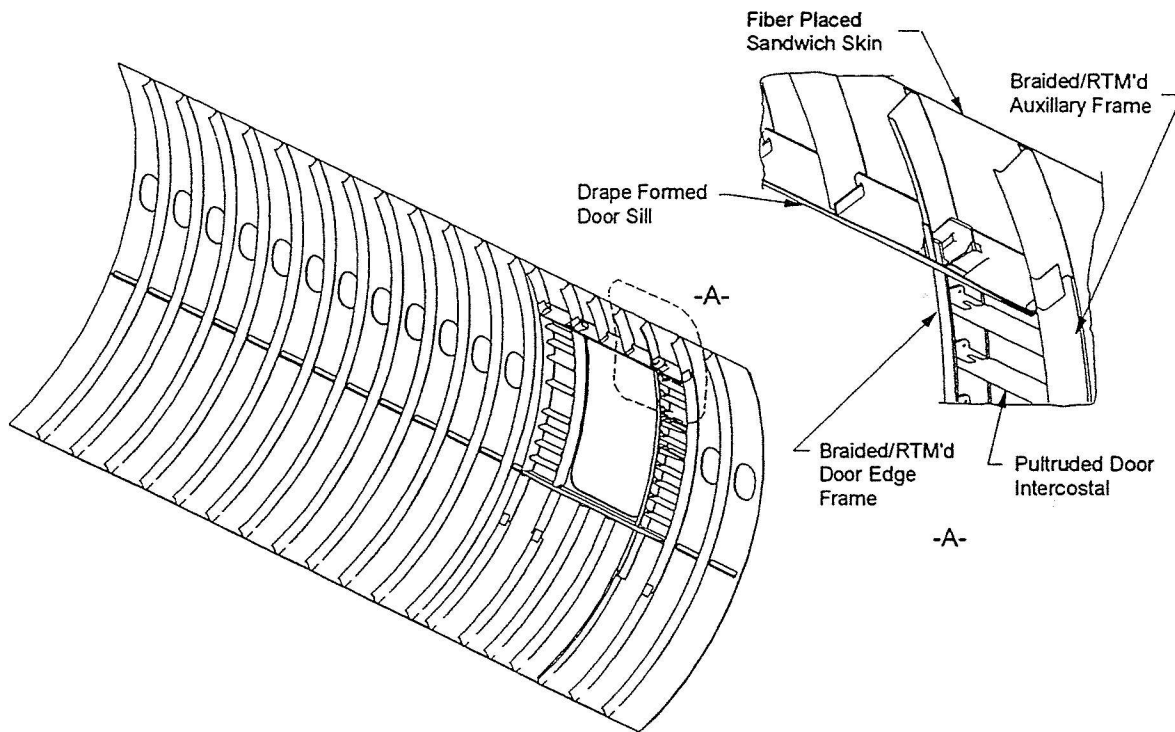

Figure 5-7. Baseline side panel configuration (passenger floor structure omitted for clarity).

Some differences exist between materials used in the keel and side. Side element designs for door sill chords, door intercostals, and passenger floor beams and stanchions used an intermediate modulus carbon fiber (IM6). These selections were based on the importance of stiffness in these elements. All other composite components in the side quadrant used a standard modulus carbon fiber (AS4). Again, cost and weight trades suggested that more expensive fiber types were not worth the weight savings possible in most side quadrant applications. The same resin matrices selected for the keel were used in the side quadrant, depending on the material form and process used for specific detailed parts. Honeycomb core material selected for the side panel was Korex-1/8, with a density of 4.5 lb/ft³. This differs from the keel core selection based on side panel trade studies which indicated affordable weight savings. Lockheed was responsible for the design and development of side circumferential frames and window ring frames under their ACT contract (NAS1-18888, refs. 23-26). Northrop had ATCAS subcontracts to support the design and manufacturing development of selected passenger door design details (e.g., braided/RTM auxiliary door frames). Additional details on side materials, processes and manufacturing methods can be found in refs. 8 and 11.

The selection of a sandwich design concept in side global evaluation (ref. 5) represented a major milestone in the ATCAS program. As discussed in Section 6.1, this decision was driven by the cost savings potential of sandwich concepts. The selection of a sandwich side quadrant also allowed joint development of side and keel technology in 1994 and 1995. Seven technical issues for sandwich structure were identified as critical items to address in this development. They are listed as follows:

- **Reliable & cost-effective design details**
(including assessments of good and bad service experiences)
- **Sandwich close-outs, attachments, and splices**
- **Manufacturing scale-up & detail strength evaluation**
- **Bonded frame integrity**
- **Sandwich panel repair**
- **Sandwich environmental durability**
- **Sandwich damage tolerance**

This section will focus on a review of the first issue. A synopsis of progress with the others is presented in Section 7, including references for reports with more detailed discussion of the ATCAS database.

The first step of designing reliable and cost-effective structural details is to try to understand the history of sandwich parts that are currently flying in the commercial aircraft fleet. Taken as a whole, this is a complex task. There are design and fabrication quality issues from the manufacturer's side. From the airlines, insights range from horror stories to outstanding success, depending on who is consulted. Given these limitations, the facts and data that are currently available are the detailed reports that were received from the airlines on parts involved in the NASA-sponsored ACEE programs. These include composite sandwich parts, such as the ones shown in Figure 5-8, which were designed and manufactured to replace metal components that served the same function. Five shipsets of 727-Elevators have accumulated more than 331,000 hrs./189,000 cycles total in the fleet, and 108 737-Spoilers have accumulated more than 2,888,000 hrs./3,781,000 cycles total. The service exposure data collected for these parts has not indicated any durability or corrosion problems.

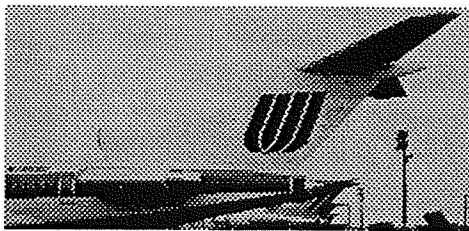

727 Elevator

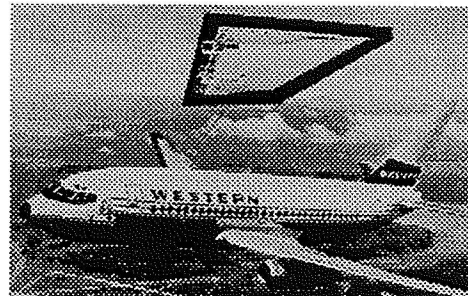

737 Spoiler

Figure 5-8: Sandwich panel design precedents.

Many production graphite-epoxy sandwich parts, such as trailing edge panels, engine cowls, landing gear doors, and fairings have demonstrated weight reduction, delamination resistance, fatigue improvement and corrosion prevention. Some thin-gage graphite-epoxy sandwich panels have had poor service records, due to issues such as fragility or inclusion of non-durable design details (e.g., improper core edge close-outs). One item that could have led to some of the design problems may be insufficient technology transfer from development efforts such as the successful NASA-ACEE programs.

Activities performed to support side quadrant development have utilized COSTADE in refining panel design details. The upper picture in Figure 5-9 shows how the side panel was segregated into zones during global evaluation. The worst loads in each zone dictated panel design for that entire region. The COSTADE analysis broke the side panel into 220 elements, with blending routines keeping track of ply layups across the panel so as to minimize starts and stops in ply layups. The lower graphic in Figure 5-9 shows the side panel zones used in COSTADE analysis, with shading that represents the shear stiffnesses per unit width for corresponding design optimization. Much of the upper aft portion of the panel is designed by damage resistance criteria (at least eight plies per facesheet); therefore, the resulting stiffnesses are slightly lower than the lightest shade of elements seen elsewhere. Since the keel is redistributing the load away from the narrow load path at the forward end, its stiffnesses are the same as or higher than the lower side, with values climbing up over 1 million lb./in. Door padup regions are not highlighted because their stiffness exceeds the darkest shade used in Figure 5-9. While the shear stiffness per unit width is less than 350,000 lb./in away from significant load redistribution areas such as the forward keel or door cutout, they are still higher than the crown.

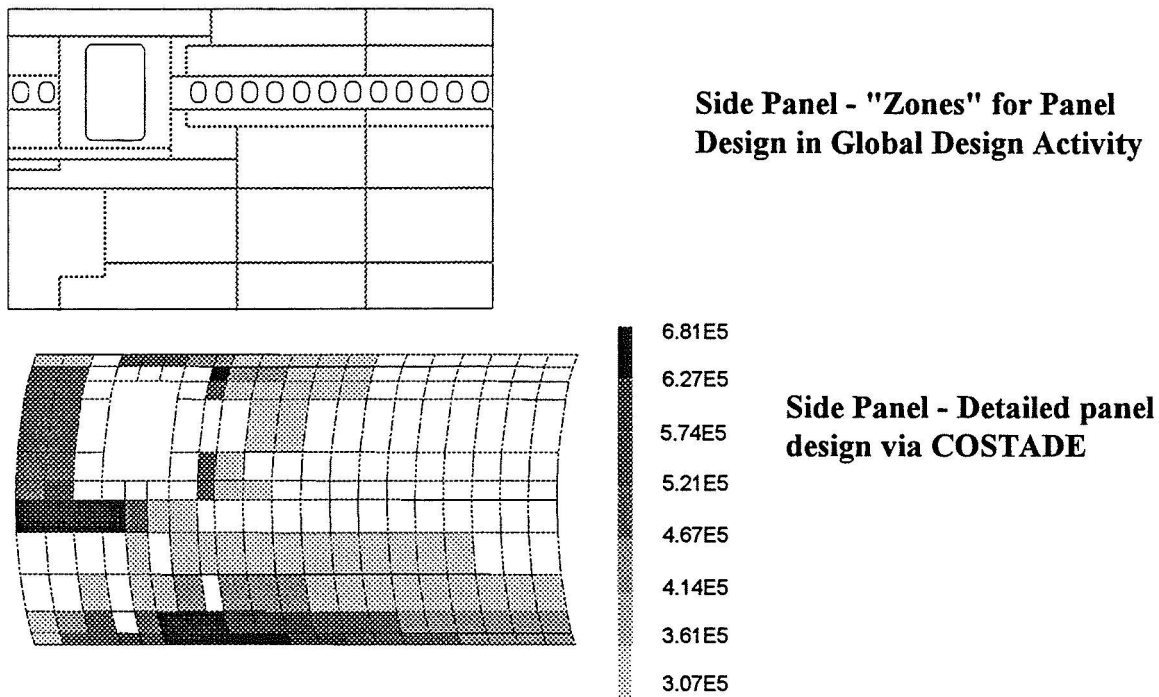

Figure 5-9: Side panel design refinement using COSTADE.

The window belt region received only preliminary evaluation during the side panel global evaluation study. However, significant detailed analysis of this area was performed in 1994 and 1995 to support the design definition of subcomponent panels for manufacturing scale-up and structural evaluation. Several window belt design details have been investigated for a number of load cases from the forward end of Section 46. The window belt area selected for study represented a zone with relatively high loads but without any local influence from the over-wing longerons. The variables considered included layup, number of plies, window belt doubler width, window frame shape and size, and window close-out material and configuration.

Finite element analyses helped to (a) optimize the layup and width of the window belt doubler, (b) consider simpler window frame geometry (see Figure 5-10), and (c) assess differences in close-out details for the full-depth window cutout. The standard window frame in Figure 5-10 was designed to be equivalent to the original aluminum window frame, whereas the reduced height design (denoted "S" in the figure) takes advantage of the full-depth window cutout and the lack of a need for skin panel buckling restraint. Section 7.3 will give a synopsis of the finite element results. Additional details and associated results for all the configurations that were studied are given in refs. 18 and 27.

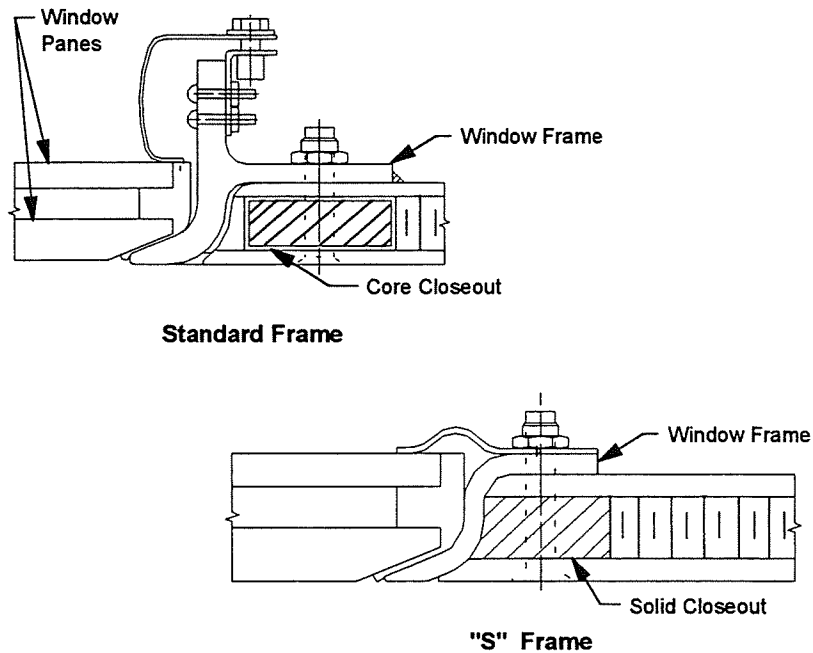

Figure 5-10: Alternate window frame design details.

Concurrent with the design study, selected window belt manufacturing processes have been under development, culminating in the fabrication of two 7-foot by 10-foot manufacturing demonstration panels with representative structural detail. Section 7.1 summarizes the associated process developments leading to these demonstrations and the subcomponent panel quality and cured tolerance measurements. Additional details on side manufacturing developments can be found in refs. 8, 23, and 28-30.

An extensive amount of design work remains to be accomplished in side quadrant concept development. As discussed in the previous paragraphs, the only detailed design work conducted for the side quadrant includes (i) zone refinement and extensive panel sizing activities using COSTADE and (ii) some detailed trade studies and sizing for windowbelt structure. Concepts identified during the side global design activity with the most attractive cost and weight reduction (see Sections 6.1 and 6.4), such as increased frame spacing (shown in Figure 5-11) or fabricating a full barrel without longitudinal splices, have yet to be studied in detail. This is largely due to Phase B resource limitations and the fact that these innovative concepts have synergistic impact on the design (both structural and systems interface) and manufacture of the entire barrel.

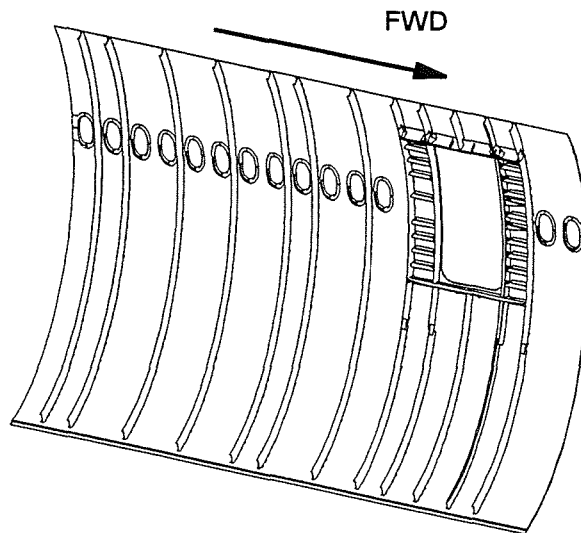
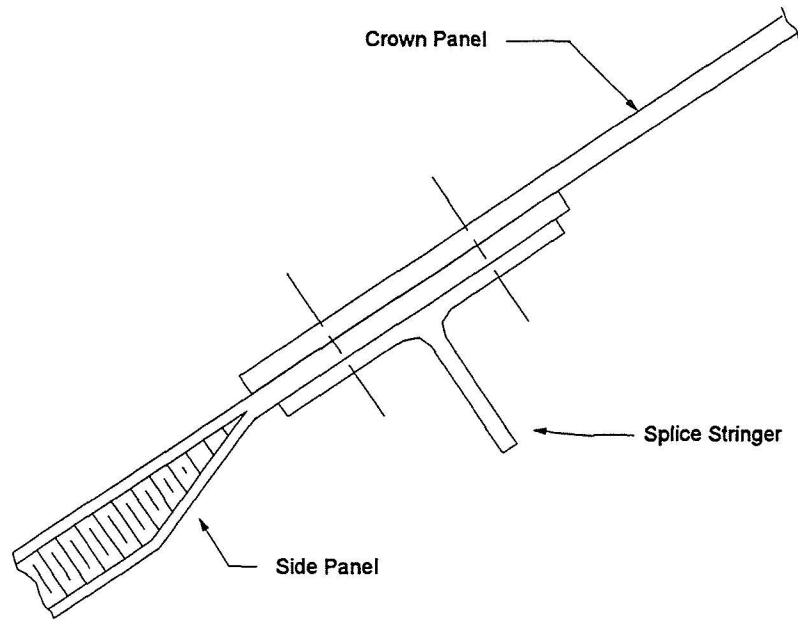

Figure 5-11: Increased frame spacing panel design concept.

5.4 Longitudinal and Circumferential Splices

Concepts for longitudinal splices between crown, keel, and side quadrants have been considered during ATCAS Phases A & B global and local studies. The same can be said for the forward and aft circumferential splices in each quadrant. Some element process trials, structural tests, and analyses were performed for both longitudinal and circumferential splice concepts. Manufacturing scale-up and structural evaluation of subcomponent splice panels require subsequent phases of study.

Some longitudinal splice concepts considered in ATCAS are shown in Figure 5-12. These lap splice concepts depend on the configuration of panels being joined (i.e., sandwich or skin/stringer). Different panel close-out concepts, ranging from solid laminate to hollow braided tubes, have been considered. Circumferential splice concepts are shown in Figure 5-13. Circumferential splice close-outs for sandwich keel and side panels are solid, and include partial rampdowns to accommodate external splice plates, while maintaining a smooth aerodynamic outer surface. The forward keel splice is more complex due to details in the wheel well cutout area and the magnitude of loads to be transferred from the keel beam.



a. Crown-to-Side Panel Splice.

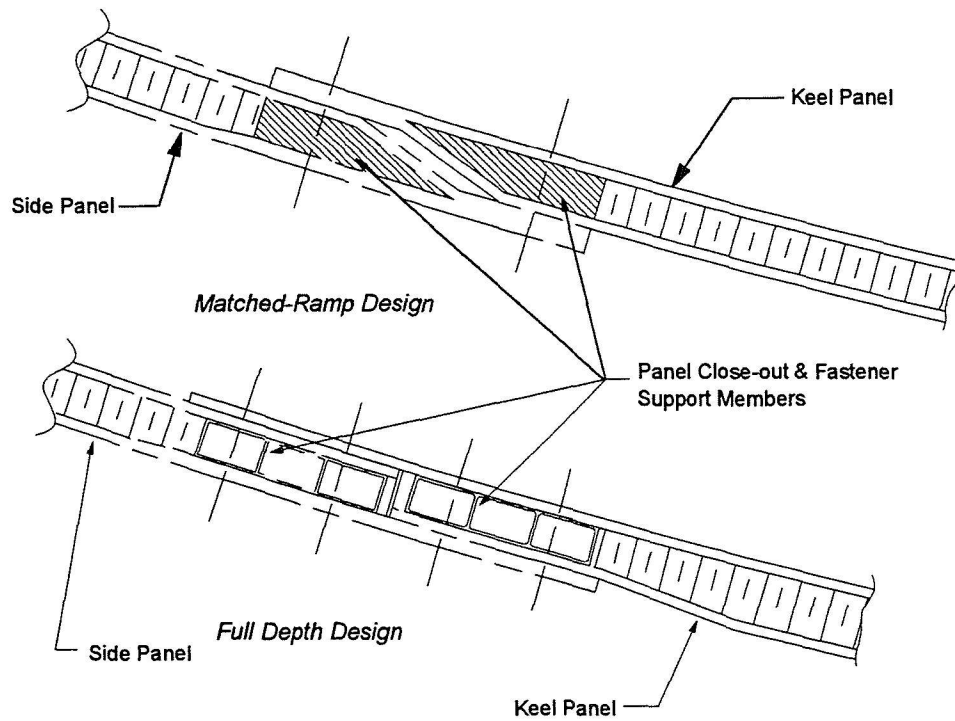

b. Keel-to-Side Panel Splice Concepts.

Figure 5-12: ATCAS design concepts for longitudinal splices.

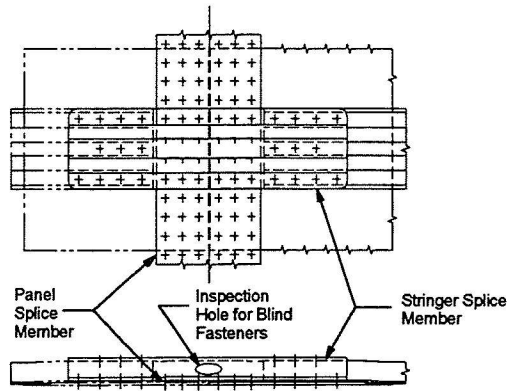

a. Crown (Skin/Stringer)
Circumferential Panel Splice

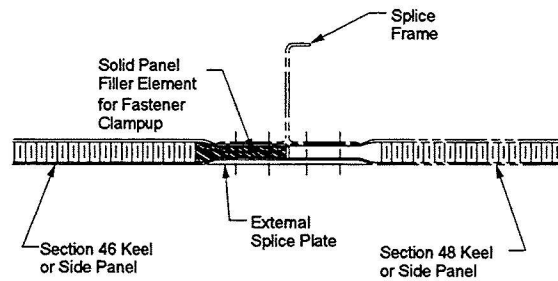

b. Aft Keel or Side (Sandwich)
Circumferential Panel Splice

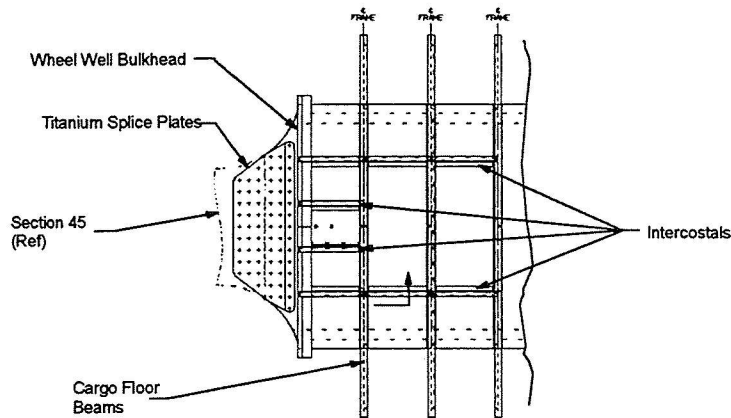

c. Forward Keel Circumferential Splice

Figure 5-13: ATCAS design concepts for circumferential splices.

5.5 Critical Issues

Fifteen technical issues for baseline composite fuselage concepts were recognized as critical areas of technology development during the course of ATCAS studies. These issues appear in the low level boxes shown in Figure 5-14. Sections 5.5.1 through 5.5.15 provide a brief introduction of what each issue involves. Four elements of risk are also shown in Figure 5-14 as column headings that classify different types of issues. All critical issues combine to affect the overall program risk, denoted as the cost-optimized fuselage barrel in the figure. A complete set of issues were considered during concept selection. Many issues were also addressed in manufacturing demonstrations and structural evaluation. For example, the issues listed in Section 5.3 for ATCAS sandwich concept development are a subset of those shown for the integrated fuselage in Figure 5-14.

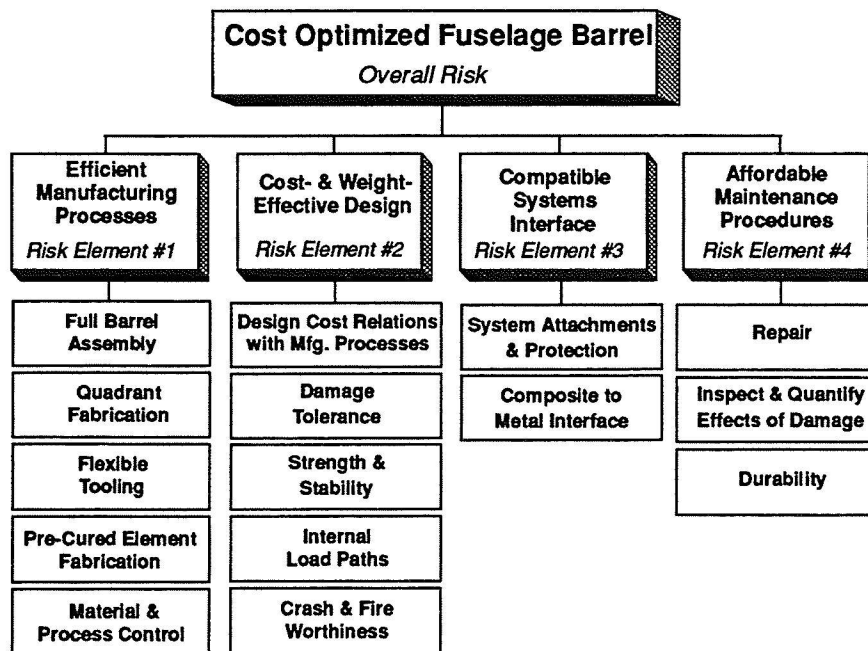

Figure 5-14: Critical fuselage issues for baseline ATCAS concepts.

5.5.1 Full Barrel Assembly

Assembly of the full barrel, including panel and floor-structure subassembly, is a major cost center. The assembly costs of composite configurations must be minimized to counteract their higher material costs (composite and titanium fasteners) and achieve the desired cost advantages over metallic configurations. Lower costs are possible with ATCAS large quadrant panel sizes through a reduced number of major splices. Cocured and cobonded elements included with ATCAS baseline concepts also minimize subassembly operations assuming the cured element location tolerances and overall panel dimensional stability is achieved.

Additional assembly cost reductions can be obtained through changes in the tooling requirements and improved drilling/fastening methods. Assembly tolerance payoff of the

large configured ATCAS quadrant panels, however, is reduced due to their higher stiffness. To avoid the high costs of shimming joined interfaces, manufacturing tolerances critical to the assembly process must be identified and controlled. Fabrication and assembly capabilities must also be integrated with design methods to provide robust splice designs.

5.5.2 Quadrant Fabrication

To achieve program cost goals for composite fuselage, cost-effective fabrication processes for large configured quadrant panels must be developed. These processes must meet dimensional tolerance requirements that are acceptable for barrel assembly. Specifically, efficient layup of large tailored skin panels and stiffening elements, and subsequent control of panel thickness, element location, and panel deformations during cure are required. Methods for machining, forming, and splicing honeycomb core and for transferring and locating skins and core blankets during panel bond assembly must also be suitable for large quadrant sizes and element locational-accuracy requirements (e.g., window close-outs, attachment inserts).

Predictive methods (e.g., panel cure and warpage models) for determining the effects of design, tooling and process modifications on cured-panel characteristics support the cost-effective development of acceptable designs. Material and manufacturing-induced properties that are representative of selected processes must be quantified to perform such analysis. Results from subscale manufacturing trials can also help calibrate the models. The improved analysis can then be extrapolated to predict full-scale structure.

5.5.3 Flexible Tooling

Tooling for precured element fabrication, panel cure, and barrel assembly should compensate for design modifications related to typical loads updates and configuration changes without major rework. The importance of this issue will continue to increase into the twenty-first century as manufacturing agility is required for market-driven variations in product forms.

Many tooling concepts currently used for curing composite parts and assembling fuselage components require dedicated tools for each part. Extensive rework or complete replacement is often needed to accommodate design modifications. Tooling flexibility increases individual tool costs, but reduces the number needed and accommodates a range of design changes. However, it may also reduce tolerance control. An optimum balance must be sought between tooling flexibility, production requirements, and cycle-time.

5.4.4 Pre-cured Element Fabrication

Processes for full-scale precured composite elements with representative detail must be developed to meet manufacturing tolerance and cost goals for quadrant fabrication and barrel assembly. Proper tool design is required to attain uniform fiber/resin distributions and part cure. Dimensional tolerance control, which is influenced by processing parameters, part size, design details, and tool design, is necessary to maximize bondline

strengths and minimize splicing costs. Reliable surface preparation methods for bonded elements are also necessary to ensure consistent bondline strengths.

5.5.5 Material & Process Control

Efficient material and process control methods must be developed to ensure consistent performance of composite structures at an acceptable cost. Manufacturing costs are adversely affected by poor part quality (rework, repair, high scrap rates) and excessive dimensional variation (assembly difficulties, tolerance stack-up, shimming), while the associated variations in structural performance necessitate conservative design practices. Relationships between part quality and structural performance can be used to minimize total part cost by eliminating unnecessary limits on manufacturing tolerances and process parameters. In-line and post-fabrication inspection methods are required to control key attributes and ensure adequate structural performance.

The repeatability of automated processes, relative to traditional manual fabrication methods, should allow more efficient process control techniques to be applied. Fiber-tow prepregging, AFP, braiding, RTM, and pultrusion processes are evolving technologies for which process control methods are currently being established. Existing technologies such as honeycomb core manufacture, which have been optimized for secondary structure, may require improved process control methodologies for primary structural applications. The same may be true of the cure processes for large parts with highly varying design detail.

5.5.6 Design Cost Relationships With Manufacturing Processes

Design of cost- and weight-effective fuselage requires consideration of aircraft mission requirements and objectives, structural performance, and manufacturing costs. Traditional approaches of optimizing structural weight prior to addressing manufacturing methods result in excessively costly designs. Manufacturing process costs must therefore be considered throughout the design process. Materials must also be selected to balance performance and cost.

Cost-effective manufacturing methods alone are not sufficient to guarantee low costs. Subsequent design refinements must be directed to ensure the efficient use of selected processes. Individual manufacturing process efficiencies can strongly affect overall factory flow, and the associated rate tooling and factory space requirements. Cost prediction techniques for fabrication and assembly methods are needed for considering these aspects throughout the design process. As discussed in Section 3.2.2, procedures and design tools used to assess costs must be compatible with future desires to reduce product definition cycle times.

5.5.7 Damage Tolerance

Damage tolerant composite designs and the associated database must be developed to achieve safety standards which meet or exceed those of current aircraft structures. Important fuselage-related aspects include combined loads, damage-tip surface deformations resulting from internal pressure, and dynamic pressure release for discrete

source threats. The critical damage types (e.g., most severe, but least visible) must also be determined and growth characteristics understood to support damage tolerant design and affordable maintenance practices for selected composite concepts.

Specific issues related to ATCAS baseline design concepts include:

- (a) selection of specific material/laminate combinations,
- (b) effectivity and degradation of bonded frame and stringer attachments to the skins,
- (c) effects of eliminating direct stringer-to-frame structural clips in the crown,
- (d) lack of axial tear straps for damage arrestment in sandwich panel designs, and
- (e) behavior of sandwich skins related to load redistribution between facesheets in the presence of through-thickness damage asymmetries.

5.5.8 Strength and Stability

Complimentary stress analysis and allowables methods are needed to accurately predict the strength and failure mode of critical structural details for efficient structural configurations. Predictive techniques must account for the curvature and highly-varying combined loads present in fuselage structure. Efficient load paths near areas of significant variation in structural detail must be developed by iterating the design, local analyses, and global loads model results. Methods for extending subscale test results to full-scale configured structure are required to ensure time- and cost-effective application of the technology. Consideration of material forms, fiber architectures, layups, configurations, scale-induced attributes, and manufacturing processes during stiffness and strength characterization is critical.

Important stiffness-related issues include:

- (a) load distribution in the vicinity of splices and discontinuities, including cutouts, ply-drops and impact damage;
- (b) stability performance of sandwich structure in the presence of combined compression/shear loading, disbanded and/or damaged facesheets, frame and/or intercostal details, and rapidly varying facesheet thicknesses, and
- (c) load redistribution in post-buckled stiffened-skin concepts.

Strength issues include:

- (a) combined loads effects,
- (b) fastener load share, nonlinear bearing response, load redistribution, and failure in multi-fastener splices,
- (c) interactions with major cutouts, and
- (d) failure modes of medium- and heavy-gage sandwich structure, thick solid laminates, textile fiber architectures, and skin/frame bondlines.

5.5.9 Internal Load Paths

Verified analytical techniques for simulating internal load paths in aircraft structure are needed for confident design development. Significant load variations are present in fuselage structure due to the presence of large cutouts (e.g., doors, wheel wells). Composite material anisotropy, post-buckling behavior, low transverse properties, and possible non-local response significantly alter internal load distributions from those of isotropic metal materials. Flexibility and local failure in mechanically-fastened joints also affect distributions.

Representation of composite behaviors in global models for the several hundred load cases typically considered in production programs is currently limited by constraints on model size, solution cost, and schedules. Advancements in computational speed/storage and modeling/interpretation tools, however, are beginning to relieve these constraints. Semi-empirical material properties and structural representations may be required to accurately predict general load distributions with linear solution of global models.

5.5.10 Crash and Fire Worthiness

Fuselage structural configurations need to protect passengers from specified crash loads, and provide some protection during post-crash fires to allow time for passengers to escape from the aircraft. Requirements (i.e., FAR 25.561) and objectives related to emergency landings and ditching for current aircraft types are designed to provide passengers with a reasonable chance of surviving the impact and evacuating the airplane. Structures supporting seats and interior components must be designed to withstand inertial loads in such situations without failure or deformation which would impede subsequent passenger egress. Emergency evacuation doors must be resistant to structural deformations that would cause them to jam during such landings. The design of composite fuselage structure to meet current emergency landing requirements is not expected to result in additional weight.

Current requirements and objectives related to post-crash fire protection were developed around the ability to evacuate passengers from aircraft with aluminum fuselages. Criteria need to be established for composite fuselages to ensure equivalent safety levels. The key concern is whether the use of composite materials would adversely affect passenger evacuation. Composite materials are expected to offer better stiffness and strength retention in a fire than aluminum, thereby delaying loss of structural integrity. In addition, composites have been shown to be more resistant to burn-through than aluminum and are expected to be more effective in protecting the passenger compartment from an external fire. Composites are also expected to act as a better thermal insulator, reducing the risk of auto-ignition and smoke emission from interior materials. However, the composite material itself may ignite, introducing fire into the airplane interior. Smoke evolved by the composite on the cabin side may enter the passenger cabin and inhibit passenger egress. Generation of combustible smoke could result in a flash fire within the fuselage cabin.

5.5.11 Systems Attachments and Protection

Composite fuselage designs must consider systems interfaces (e.g., attachments, interiors support structure, penetrations, lightning protection) to ensure total cost savings over conventional fuselage structure. Design details associated with these systems often increase part complexity, eroding cost and/or weight savings. Lightning protection systems, if required, often involve the addition of metallic fiber coatings, meshes, or straps.

Local padups and mechanically fastened attachments may be required for some systems, depending on specific load levels. Fastened attachments and penetrations in sandwich panels must not provide moisture ingress paths. The effects of local inserts used for these sandwich design details on manufacturing processes (e.g., core blanket fabrication) and cured panel tolerances will also need to be understood.

5.5.12 Composite to Metal Interface

Technology to interface composite and metal structural components must be resolved for optimized fuselage structures utilizing advantages of both classes of materials. Areas of significant metallic applications likely include the wing-to-body intersection (e.g., wing carry-through structure, main landing gear fittings) and the nose section. Solutions to the composite to metal interface issues may also allow earlier application of composite components in fuselage structure.

Important issues include safety, corrosion, mechanical joints, and durability. Efficient electrical isolation schemes at composite-to-aluminum interfaces are needed to inhibit galvanic corrosion of the aluminum. The differing stiffnesses and thermal expansion properties can also induce significant loadings where the materials are joined, affecting load sharing, static strength, and durability.

5.5.13 Repair

The acceptance of composite fuselage technology by production and airline maintenance personnel requires repairable design details, damage tolerant designs, and cost-effective and reliable repair methods. Repair issues must be considered throughout the design process to ensure development of cost-effective, repairable concepts that achieve a balance between structural weight and inspection/repair frequency. Joint efforts involving the appropriate personnel from both the manufacturer and airline can also help ensure the necessary maintenance technology is developed.

Maintenance procedures must be developed which allow economical operation of the aircraft while retaining the high safety levels exhibited by present technology. Clear, accurate instructions for rapid assessment and disposition of detected damage must be based on structural capability. Multiple repair options (e.g., bolted vs. bonded, temporary vs. permanent) and material/concept commonality across multiple locations will aid in minimizing airline maintenance costs. Efficient and reliable repair processes must be developed to address a range of damage scenarios, structural detail and on-airplane access. Inspection methods are required to ensure proper repair of critical damage.

Reliable analytical methods are also needed to ensure that repairs satisfy structural requirements.

5.5.14 Inspection and Quantification of the Effects of Damage

Cost-effective inspection methods suitable for aircraft maintenance are required for detecting and characterizing potential in-service damage. Damage resistant materials and structural design details are needed to minimize the need for repairs in service and to ensure long-term durability. Methods for quantifying the effects of damage on structural strength are necessary for rapid assessment and disposition of detected damage. Reliable non-destructive evaluation (NDE) procedures for damage characterization and models for predicting damage growth are needed to support these methods.

5.5.15 Durability

Demonstrating the durability of composite structures is essential to obtaining airline acceptance of composite fuselage design concepts. The durability of sandwich structures, full-depth sandwich splices, and bonded attachments are of particular concern. Materials and design details resistant to fatigue damage or defect growth under fatigue loads are also desirable. Accurate models for predicting fatigue damage formation and growth, and growth of manufacturing defects are needed to establish appropriate inspection intervals.

Environmental effects on material and structural performance must also be considered in design. Materials must be resistant to degradation by exposure to typical aviation fluids. Sandwich facesheets and core close-outs must be resistant to moisture ingress. Core materials must also be resistant to moisture migration from local ingress points such as those caused by barely visible damages.

6.0 COST AND WEIGHT ASSESSMENTS

Cost and weight assessments have been performed in the ATCAS program since 1990. The DBT approach to select initial concepts involved some modification to the serial process routinely applied by industry (i.e., design, followed by the definition of a manufacturing plan which, in turn, facilitates cost and weight estimates). The main difference in the initial concept selection applied by ATCAS related to the communication created between functional disciplines, allowing some parallel processing of the design and manufacturing data that affect cost. Over time, the ATCAS database and cost modeling tools established under the COSTADE initiative (ref. 14) allowed more efficient cost estimates of the evolving design and manufacturing concepts. The evolution of ATCAS cost and weight assessments formed the basis of a theoretical framework for design cost modeling. This framework is described in detail by ref. 10.

Cost estimates performed by ATCAS followed the ACT cost groundrules (see Table 6-1). Although capital costs are not directly assessed, recurring and nonrecurring wrap rates imply a burden factor which indirectly accounts for some capital costs. Future studies plan to consider a more rigorous assessment of the capital costs for specific concepts.

ACT Ground Rules for Recurring Costs:

1. Production is based on a total of 300 shipsets at a rate of 5 shipsets per month.
2. Labor is estimated at the detail process level.
3. Machine times are based on performance data provided in the automation plan.
4. Material is based on total area or volume required to produce a part, including an appropriate process-based utilization rate.
5. All costs are based on 1995 dollars.
6. Recurring labor wrap rate is assumed to be \$100/hr.

ACT Ground Rules for Nonrecurring Costs:

1. Rate tooling is included to support a monthly rate of 5 shipsets.
2. The estimate assumes that all innovative ideas created for technology of 1995 will be obtainable.
3. The estimate assumes a dedicated facility and equipment to minimize factory flow and hand labor.
4. Capital equipment and facilities costs are not included.
5. Nonrecurring labor wrap rate is assumed to be \$75/hr.

General Approach Used By ATCAS: *Cost assessments used detail design and manufacturing definitions, and continuous discussions between the DBT and cost estimating group. An automated factory was assumed for definition of equipment and tooling. Focus was on (1) efficient processes, (2) the reduction of part count and handling steps, (3) low cost composite materials, and (4) the combination of manufacturing operations where beneficial.*

Table 6-1: Ground rules for ATCAS cost estimates.

This section of the report is broken into six main parts. The first compares the cost and weight savings potential of ATCAS concepts with state-of-the-art aluminum. The costs shown versus metal in Section 6.1 utilize detailed estimating procedures applied during the course of ATCAS. At the start of Section 6.2, cost predictions from detailed estimates are compared to those obtained with the ATCAS design cost model completed in 1995. The rest of Section 6.2 describes components of design cost model predictions for the entire ATCAS barrel. Sections 6.3 through 6.5 discuss components of the design cost model predictions for each quadrant. Section 6.6 provides some insights on possible changes in the quadrant panel sizes for subsequent phases of ATCAS.

6.1 Totals from Detailed Estimates versus Existing Aluminum

Throughout the program, composite concepts have been compared to aluminum. Although more mature than composite technologies, aluminum processes have continued to advance. For example, more efficient weight tailoring of detail aluminum parts has become possible with high speed machining.

The current aluminum baseline used in ATCAS trade studies represents existing 1995 practices for transport fuselage structure. The assumed factory includes specialized, highly automated, manufacturing cells. Skins consisting of polished aluminum alloy are high speed milled, stretched, and roll formed. Extruded and roll-formed stringers are also tailored utilizing high speed machining. Stretch formed frames are chemically milled. Precise automated assembly procedures are used to minimize tooling.

Structural optimization related to a detailed understanding of the fuselage load paths have led to lighter-weight aluminum designs. Process advancements, such as high speed machining, have made such weight savings affordable. The weight of aluminum concepts have also decreased because allowable design stress levels have increased for some advanced alloys. As will be discussed in Section 7.2 and 7.3, properties such as fracture toughness and fatigue resistance are crucial to damage tolerant fuselage design. Key processes for advanced aluminum alloys, such as skin forming, have been demonstrated at a large scale, allowing production applications.

As discussed in Section 4.2 and 4.3, each quadrant has been subjected to global cost and weight evaluations to select concepts for manufacturing, structures, and maintenance developments. Due to the large panel size and considerable design detail, the most extensive global evaluation was performed for the left side quadrant in 1993 and 1994 (refs. 5, 31 and 32). The cost and weight space for skin-stringer and sandwich thermoset composite concepts considered in this study are shown in Figure 6-1. Sandwich concepts were found to have significantly higher cost savings potential and possible weight advantages; however, also thought to have greater technical risks. Note that the full potential of composite concepts shown in Figure 6-1 have not been quantified (i.e., resizing for weight saved will yield lower loads and other benefits, e.g., smaller engines).

Cost savings potential for the composite sandwich concepts plotted in Figure 6-1, represent a significant breakthrough in fuselage technology. The baseline composite

concept (located roughly in the middle of the space shown in the Figure 6-1) has 80% reductions in both the number of detail parts and fasteners versus aluminum. Advanced composite fabrication processes found to be efficient include AFP for skin lamination, textile/RTM for frames, a pre-assembled honeycomb core blanket, and a low-pressure autoclave cure cycle. Material costs are kept relatively low by using an inexpensive graphite/epoxy skin material and the low buy-to-fly ratio possible with AFP. The sandwich concept and an outer mold line (OML) tooling approach was thought to provide some tolerance payoff in subassembly prior to cure. This was also thought to yield design flexibility for airplane growth (e.g., skin gage/honeycomb core thickness trades to achieve the required load carrying capability).

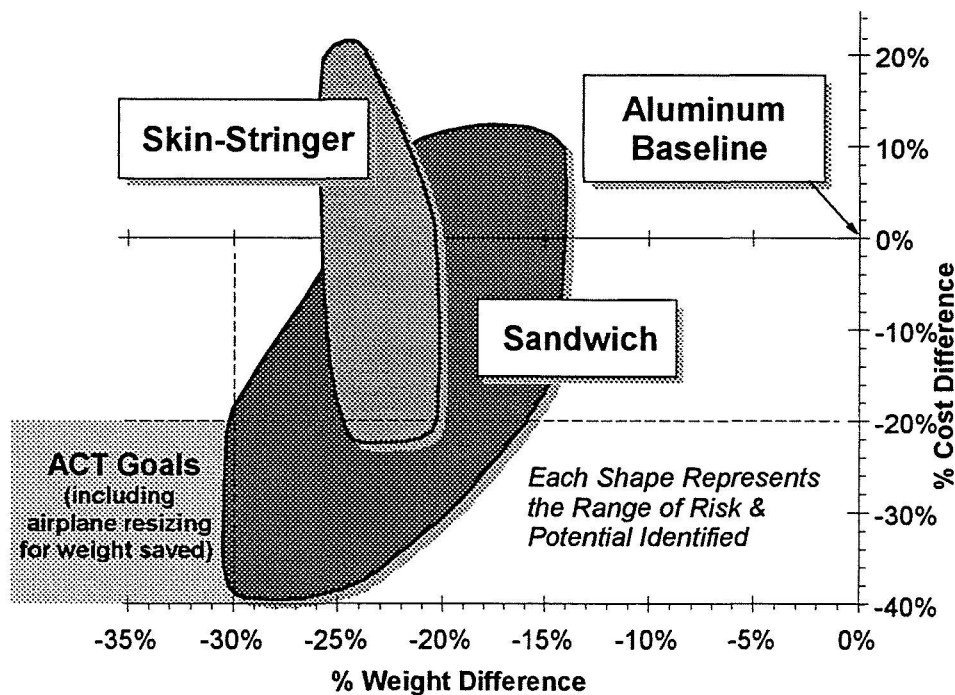

Figure 6-1: *Cost and weight space for side quadrant concepts considered in ATCAS.*

Side global evaluation included risk analyses of design and manufacturing parameters that could increase cost and/or weight. These risk analyses led to points that populate the upper and right-hand portions of the space for skin/stringer and sandwich concepts in Figure 6-1 (see refs. 5 and 28 for details). One example of the risk analysis performed relates to composite material costs. The ATCAS studies assumed a lower material cost than today's market based on the potential cost reduction possible with higher quantities required for transport fuselage applications. A risk analysis assuming current material costs led to nearly a 10% increase in the total costs of side baseline concepts (ref. 5). A similar risk was quantified for the keel, while the total effect on the crown approached 20% (ref. 9). In addition to bounding an important aspect of risk, this example shows the importance of base material cost to affordable composite fuselage structure.

Side global evaluation also included potential analyses of design and manufacturing parameters that could decrease cost and/or weight. These potential analyses led to points that populate the lower and left-hand portions of the space for skin/stringer and sandwich concepts in Figure 6-1 (see refs. 5 and 28 for details). Much of the potential for side skin/stringer concepts relates to reduced shimming in assembly and the use of hat stiffeners instead of Js. The sandwich side concept also has some possible payoff due to decreased shimming but most of the potential benefits relate to advanced designs with reduced part count (e.g., increased frame spacing). This will be discussed later.

Based on cost and weight potential, the side quadrant DBT, which included members from Boeing, Lockheed, Northrop, and Sikorsky, selected the sandwich concept in early 1994. This superseded the 1990 "baseline" side quadrant (skin-stringer with bonded frames, ref. 3) which was selected without the benefit of rigorous cost and weight evaluations. The sandwich issues identified in Section 5.3 have been addressed in ATCAS since the side concept selection. Although a change to sandwich was perceived to contain more technical risks at the time, program developments in 1994 and 1995 indicate that these risks can be overcome. The cost and weight savings potential of sandwich concepts also still appears feasible.

During the course of developments for each quadrant, process steps and design details have been updated, requiring periodic revision to costs and weights. Figure 6-2 shows the 1995 total cost and weight comparison for the ATCAS barrel section. The composite cost savings meet ACT goals even without airplane resizing. A more rigorous evaluation with airplane resizing, including representative designs for other composite fuselage sections and internal loads analysis, will be required to meet ACT weight saving goals with the current concepts. Additional design progress with other fuselage sections are required to pass subsequent development stages before composite fuselage implementation at Boeing.

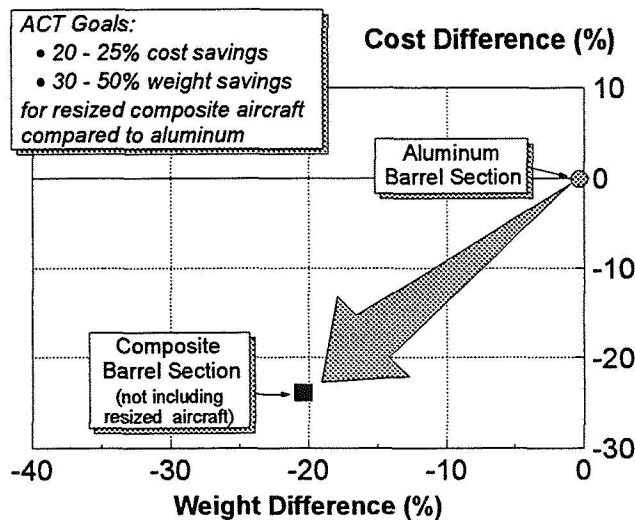

Figure 6-2: Total potential cost and weight savings for aft fuselage barrel section.

Table 6-2 lists the total cost projections for baseline metal and composite barrel sections (using ACT groundrules). Also shown are total cost changes predicted if the current baseline crown concept (hat-stiffened skin with bonded, mouse-holed frames) is converted to alternate concepts. The ATCAS program has recently considered such changes based on crown manufacturing evaluations, structural tests, and side concept selection.

	300 SS (\$M) ★	% Cost Savings
<i>Baseline Metal Barrel</i>	407	—
<i>Baseline Composite Barrel</i>	309	24.0
<i>a) Substitute bolted frames in crown</i>	319	21.7
<i>b) No shimming of bolted frames</i>	317	22.2
<i>c) Substitute sandwich crown</i>	311	23.5

★ All costs are based on ACT groundrules for constant burdened recurring (\$100/hr) and nonrecurring (\$75/hr) labor rates, independent of the process

Table 6-2: Predicted changes in cost with modifications to the crown design.

Composite cost differences in Table 6-2 reveal the effect of changing from the baseline crown quadrant to alternate concepts that include bolted frames and frame/stringer flange connections (hat-stiffened skin), or sandwich construction (with bonded frame). Note that the baseline crown design remains the lowest cost for relatively simple structural detail that is characteristic of this quadrant. There are also some weight penalties associated with changes to alternate crown concepts (ref. 33). Although the baseline crown design has some cost advantages, it was not deemed suitable for other ATCAS quadrants due to manufacturing and structures issues related to the widely spaced hat-stiffeners and the bonded mouse-holed frames. Design solutions to these issues eliminated the cost benefits. Large manufacturing demonstrations for the alternate, bolted crown design were fabricated in 1992 (refs. 7 and 34). Large aft keel manufacturing efforts in 1993 and 1994 addressed structural details similar to those for a sandwich crown design (refs. 22, 28, and 35). Technical discussions in remaining subsections will further highlight why the alternate concepts in Table 6-2 may be preferred over the current baseline crown design.

Figure 6-3 projects other cost benefits that may be possible with sandwich design concepts. The ATCAS program has started to evaluate the effects of increased frame spacing as related to side quadrant design details (refs. 27 and 33). The Beech Starship sandwich design eliminated most frames (some reinforcement was used between facesheets in selected locations) and the associated costs in pressurized fuselage for a civil aircraft (ref. 36). Over the last year the potential cost savings associated with a 360° barrel concept, eliminating the quadrants and remaining longitudinal splices, have also been investigated. Note that the cost savings potential of this concept is greater than that documented in past reports (refs. 31 and 32). This relates to significantly less process

steps (e.g., tool transfer and cleaning) identified in a more complete assessment of the cost potential for 360° concepts. Studies over the last year provide better insights into the potential cost savings and associated technical issues; however, efforts to fully understand increased frame spacing and 360° concepts for transport aircraft require an extensive look at all quadrants. Figure 6-3 suggests that such efforts are warranted.

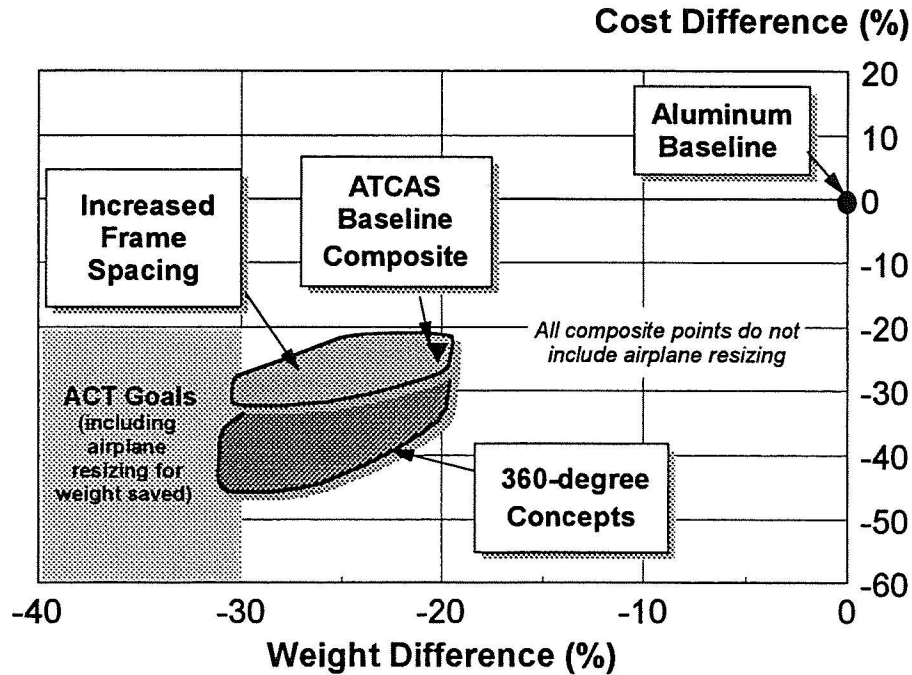

Figure 6-3: Estimates of potential improvements with further sandwich panel developments.

6.2 Design Cost Model Predictions

Detailed estimating procedures were used to predict the cost of baseline ATCAS concepts since the program start. Initial development of a more rigorous approach to cost assessment was completed near the end of Phase B (1995). This included design cost methods (ref. 10), COSTADE (ref. 14), and the associated database for ATCAS concepts (ref. 37). These tools will allow the DBT to more effectively share responsibility in obtaining credible cost predictions. At the end of Phase B, cost analysis tools were used to predict approximately 80% of the total ATCAS baseline concept costs. The remaining 20% include parts developed with the help of subcontractors (e.g., passenger door cutout reinforcement). In subsequent phases of ATCAS, the database supporting design cost model predictions will be continually updated per the best available information on evolving design and process details.

Figure 6-4 shows a comparison of predictions from detailed estimates and the design cost model for ATCAS quadrants. The latter generally predicts higher costs, with the biggest relative difference occurring for the keel. As mentioned above, about 20% of the design cost model predictions are treated as constants that were obtained from detailed estimates.

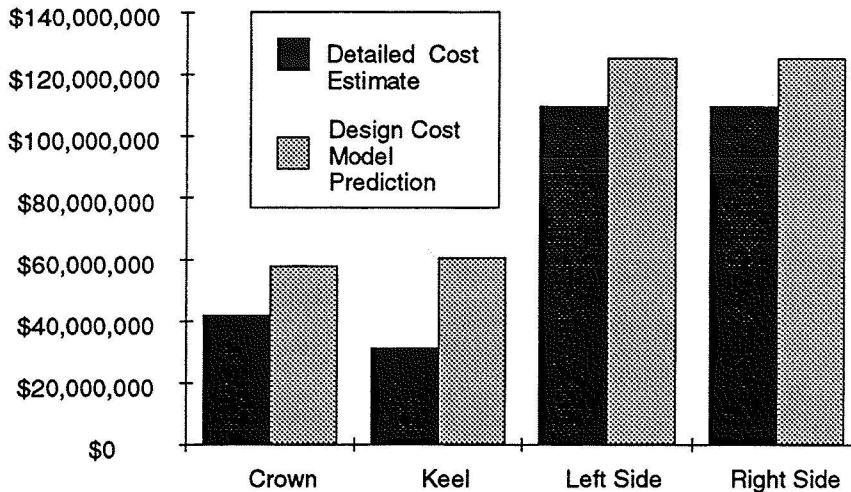

Figure 6-4: *Differences in the two methods that have been used for ATCAS cost assessments.*

The side quadrants, which are assumed to be the same for ATCAS study purposes, dominate the barrel cost primarily due to their size. The smallest relative difference between the detailed estimate and design cost model prediction occurs for the side panels. The detailed estimate for the side panel was performed in 1994. The detailed estimate for a crown quadrant panel was updated in 1993, but that for the keel represents ATCAS cost insights in 1992. Since all cost model predictions represent 1995 insights, it is reasonable to expect that the best correlation with a detailed estimate would be that for the side. Future work will further evaluate differences between detailed estimates and cost model predictions.

Other factors leading to some differences in the two methods used by ATCAS to predict cost include (a) updates in nonrecurring tooling estimates, (b) slight variations in material costs, (c) fundamental divergence in the equations used to predict process time, and (d) the addition of some quadrant inspection costs. The tooling cost estimates have generally increased as the program progressed and better process definition was achieved. The material cost database also expanded with time, leading to some small increases in this important cost center. Labor equations for the design cost model converged to steady state velocities (i.e., constant rates), while detailed estimates followed a power law that generally predicted shorter process times (ref. 10). Finally, the inclusion of quality inspection costs were not required by ACT groundrules.

Figure 6-5 shows the major components of total predictions by the design cost model. Recurring labor appears to have the largest portion of the total cost. As discussed in ref. 10, wrap rates used to convert process times into labor costs using the ACT cost estimating groundrules, imply some burdening for capital costs. The use of constant rates that are independent of the process center can be misleading versus those calculated for an actual factory. The other two major cost components shown in Figure 6-5, nonrecurring tooling and recurring material, constitute nearly the same percentage of the total.

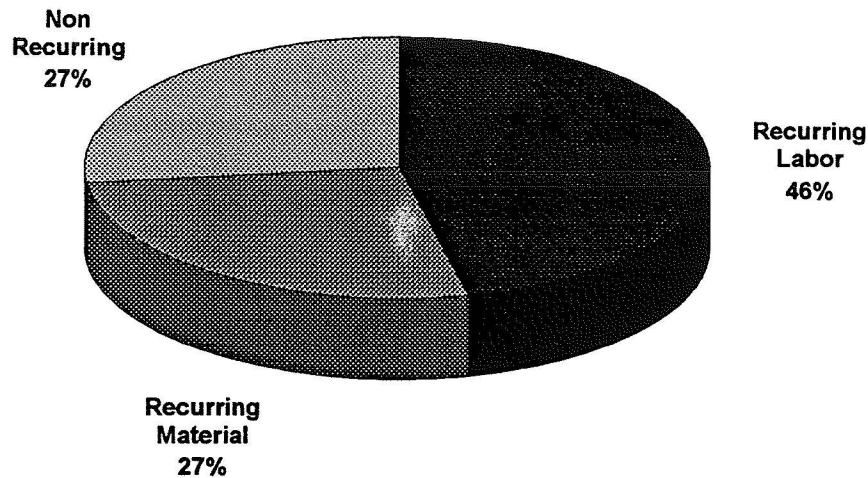

Figure 6-5: Major cost components of the ATCAS baseline concepts.

Different components of the material costs are shown in Figure 6-6. Prepreg tow constitutes the vast majority of structural weight in quadrant skin panels, and despite low AFP scrap rates, it results in nearly one-third of the total material costs. The next highest material cost center is for mechanical fasteners, which are generally titanium bolts for ATCAS baseline designs.

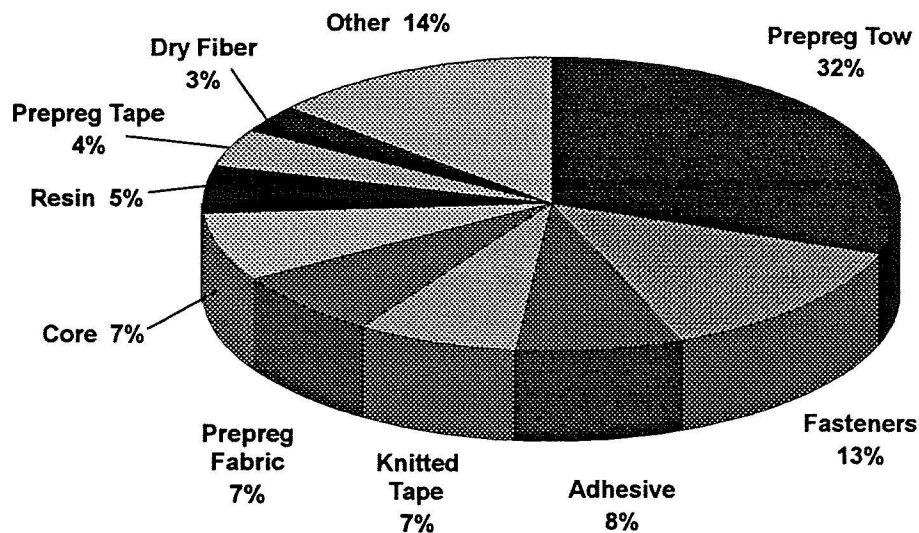

Figure 6-6: Components of recurring material costs.

As mentioned above, ATCAS tooling costs have generally increased since the program start. This relates to a better understanding of the processes and factors affecting tooling costs (e.g., substructure, handling fixtures, dimensional stability, & durability). Figure 6-7 shows the design cost model predictions for 80% of the tools used to fabricate and assemble 300 shipsets of the baseline fuselage barrel section at a rate of 5 shipsets/month. The remaining 20% of tooling costs were predicted from previous detailed estimates. Tooling costs in Figure 6-7 are dominated by those needed for quadrant panel fabrication.

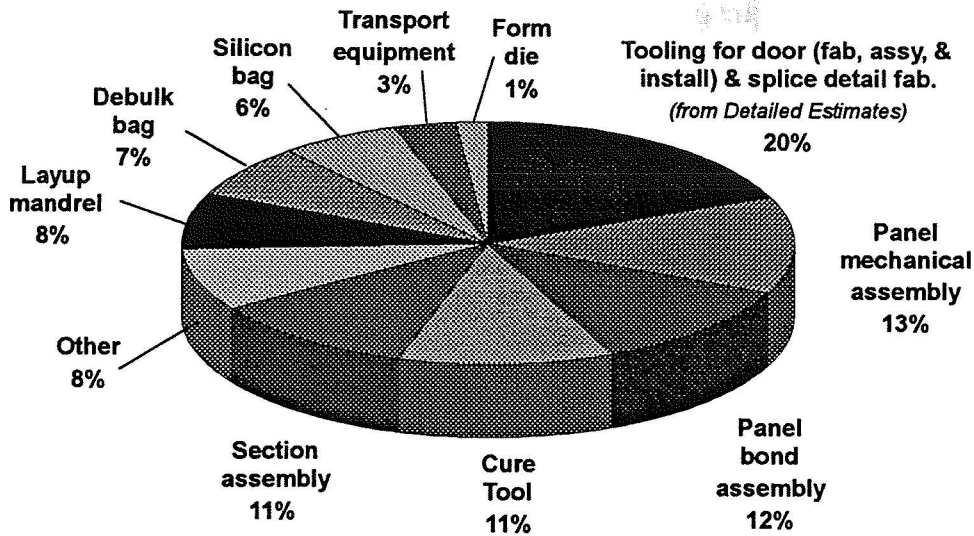

Figure 6-7: Components of tooling costs.

In addition to a dependence on the production rate, the amount of tooling depends on part commonality, processing times, and other factors that affect factory flow. For example, delays in moving parts between cells may occur due to processing constraints, ergonomic issues, maintenance, and quality rejection. Factory simulations must combine with process time predictions to establish credible tool utilization rates. As a result, tooling cost assessments must be continually updated based on the available database.

Figure 6-8 categorizes design cost model labor predictions into classes of process steps. Note the dominance of tasks to "position", "remove", or "layup" parts during fabrication and assembly. Refs. 10 and 37 provide additional details on the cost equations, critical design variables, and process coefficients that result in the summary shown in Figure 6-8. Again, 20% of labor costs were still based on detailed estimates at the end of Phase B.

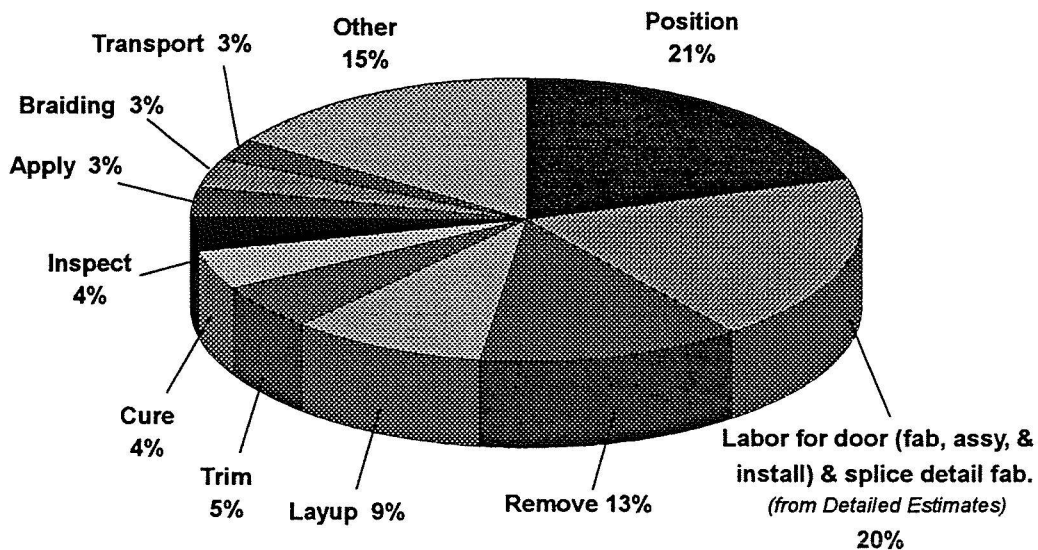

Figure 6-8: Components of recurring labor costs.

Figures 6-9 and 6-10 provide two additional ways of presenting the components of total costs (for 300 shipsets), including material, labor, and tooling. In Figures 6-9, costs are represented as a function of the major process cells (which each sum the costs assigned to multiple process steps, leading to a category of detailed part fabrication or assembly). Components of the top four processes are discussed in detail by ref. 10. Each is dominated by differing factors. For example, tow placement costs are dominated by the costs of large quantities of prepregged tow needed to fabricate all of the quadrant skins. The cost of braided/RTM frames is dominated by labor, while tooling and labor are major parts of panel bond assembly costs. The costs to assemble quadrants into a barrel include significant material (i.e., fasteners), labor, and tooling components.

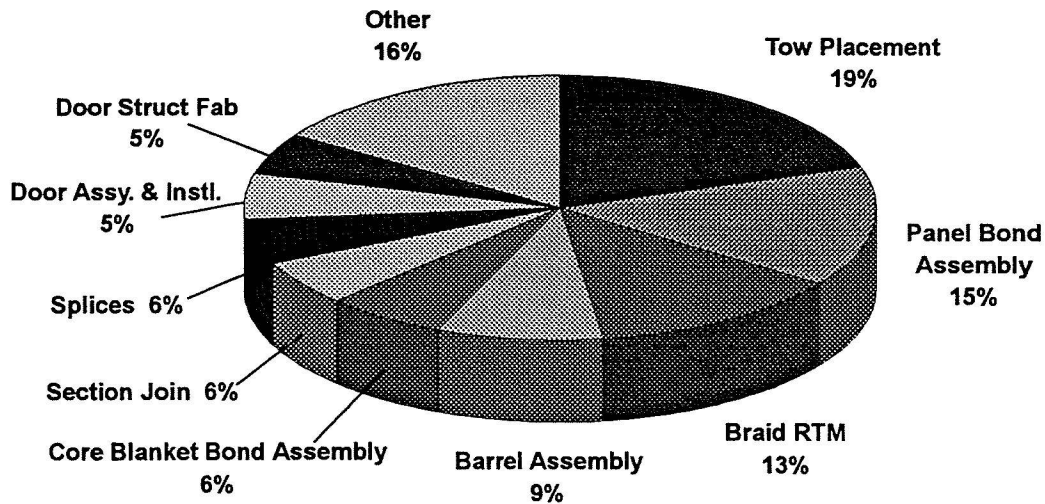

Figure 6-9: Total costs for major processes.

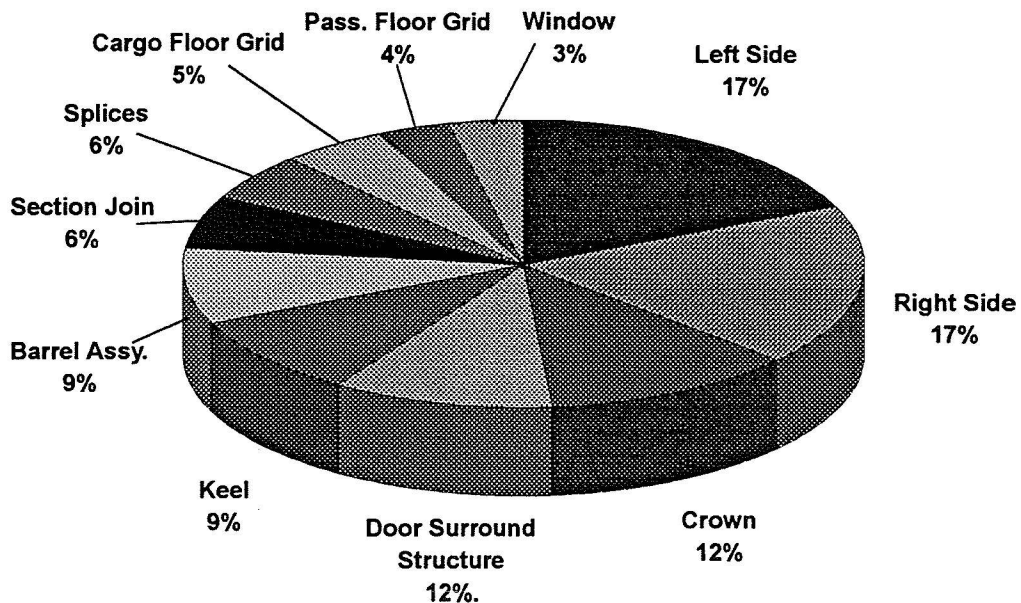

Figure 6-10: Total costs for major components.

Figures 6-10 presents cost components for detailed parts or major assemblies. As summarized in Figure 6-11, the combined cost and weight of the two side quadrants dominate approximately two-thirds of the total. The former can also be derived from Figure 6-10, considering that door, window, passenger floor, and assembly components (i.e., a share of the costs of barrel assembly and section join linked to the quadrant perimeter) are lumped with each side panel when calculating total quadrant costs. Sections 6.3 through 6.5 will briefly discuss factors dominating the cost of each quadrant.

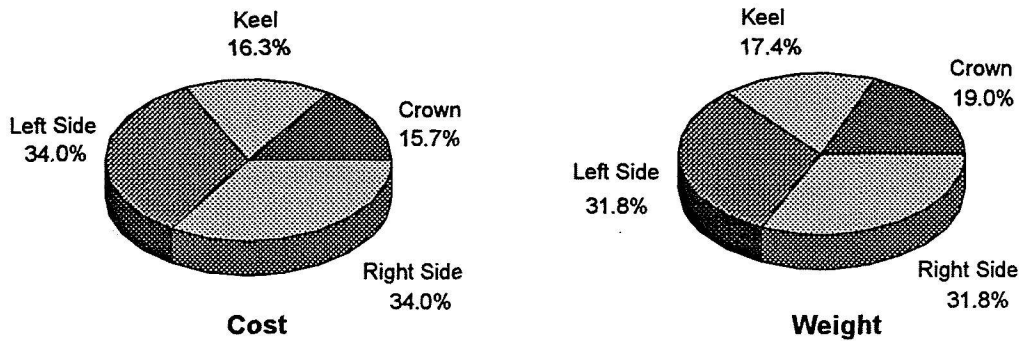

Figure 6-11: Total cost and weight distribution for ATCAS quadrants.

6.3 Crown

Figure 6-12 shows cost components of detailed part fabrication and major assembly operations associated with the crown quadrant. This includes all of the processes needed to incorporate crown panels into fuselage structure. There is no one fabrication or assembly component that dominates the costs shown in Figure 6-12. Note that the label "splices" refers to the fabrication of detailed parts used in quadrant splices (e.g., longitudinal splice stringers and circumferential skin splice plates). The label "installation" accounts for one half of the assembly labor and tooling cost of attaching the crown quadrant to (1) the left & right side panels, and (2) forward & aft fuselage sections.

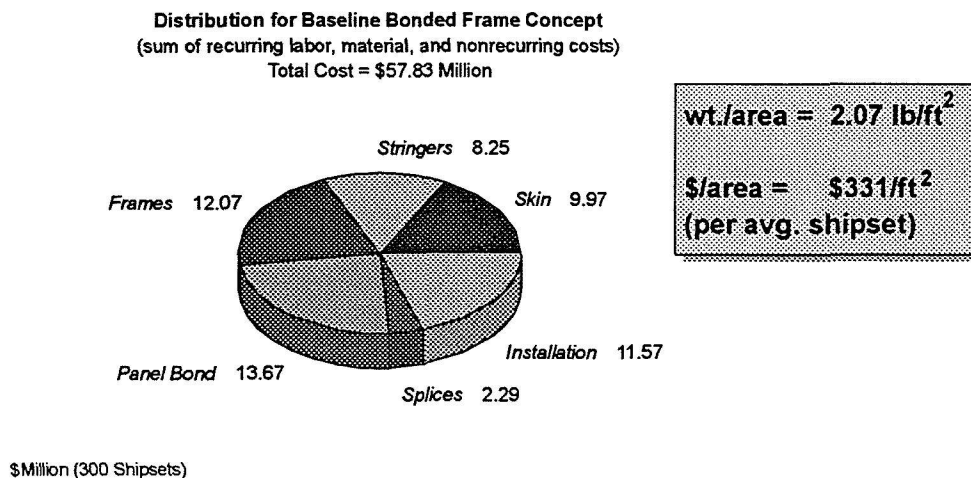

Figure 6-12: Crown quadrant cost centers.

The average crown cost and weight are expressed per unit panel area in the shaded insert added to the upper right hand corner of Figure 6-12. Both these measures for the crown are significantly lower than other baseline quadrants. Note that the measure of cost per unit area has been found to be a more revealing parameter than cost per unit weight (i.e., the main cost component related to composite structural weight is that of material).

Significant cost and weight differences exist between the baseline crown quadrant and alternate concepts studied during the course of Phase B (see discussion associated with Table 6-2). Alternates with higher cost and weight have been considered due to greater risks identified for the baseline (e.g., integrity of bonded frames with large mouseholes).

A sandwich concept has been considered to obtain commonality (e.g., materials, processes) with other quadrants and minimize the issues associated with bonded frames. The latter will be discussed in Section 7.3. Commonality is a significant benefit when considering technology development costs, maintenance issues, and material costs (i.e., larger order volumes generally reduce raw material costs). The sandwich crown cost and weight described in Table 6-2 was derived in global evaluation. Since ATCAS sandwich databases (including processes, design details, and structural properties) have increased considerably since this timeframe, some improvement in the cost and weight may be possible in future studies.

Alternate bolted-frame crown concepts have the least technical risk but highest costs. One issue that may make a stringer-stiffened crown quadrant design with bolted frames appear attractive is final barrel assembly. Barrel assembly consists of joining side panels to the keel, and then closing out the barrel by attaching the crown. It may be desirable to have the local "flexibility" of a stringer-stiffened crown panel with bolted frames (as compared to a sandwich-stiffened panel) for the last stage of barrel assembly, so as to help take up manufacturing tolerances. For example, if frames were left unbolted approaching the edge of the crown skin panel until after a splice is made with the side panel frames, some assembly payoff appears possible.

6.4 Keel

Figure 6-13 shows cost components of detailed part fabrication and major assembly operations associated with the keel quadrant. This includes all of the processes needed to incorporate keel panels into fuselage structure. As evident from Figure 6-13, installation dominates the costs in this quadrant. The category of installation accounts for one half of the cost of attaching the keel quadrant to (1) the left & right side panels, and (2) forward & aft fuselage sections. Installation also includes the attachment of cargo floor structure (e.g., stanchions and cargo floor beams) and intercostals. The cost to layup laminated keel skins using AFP is also an important cost center. Much of this relates to material costs and design complexity associated with the forward keel structure, which transitions from a thick laminate to sandwich.

The average keel cost and weight expressed per unit panel area appear in the shaded insert added to the upper right hand corner of Figure 6-13. Both these measures for the keel are

significantly higher than other baseline quadrants. Comparing Figures 6-12 and 6-13, the keel cost per unit area is seen to be approximately three times higher than that for the crown. Much of this increased cost is due to a cargo floor and load transitions near the wheel well cutout, causing greater design complexity in installation and detailed part fabrication. Despite the smaller keel panel size, greater weight per unit area also tends to increase the structure's relative cost per unit area (i.e., total weight is directly linked to material costs). Note that the keel panel is roughly one-third the size of the crown panel, but close to the same weight due to higher loads.

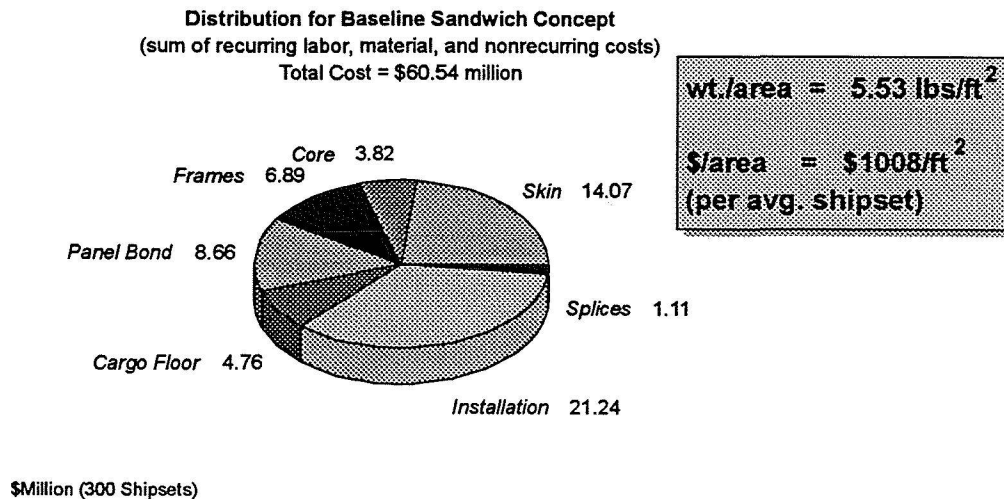

Figure 6-13: Keel quadrant cost centers.

6.5 Side

Figure 6-14 shows cost components of detailed part fabrication and major assembly operations associated with side quadrants. This combines all of the processes needed to incorporate side panels into fuselage structure, including door cutout reinforcement and passenger floor structure. As was the case for keel structure, installation and skin layup are important side cost centers. Installation accounts for one half of the cost of attaching a side quadrant to (1) the crown & keel panels, and (2) forward & aft fuselage sections. Installation also includes the mechanical attachment of (a) passenger floor structure such as stanchions and beams, and (b) passenger door cutout reinforcement.

The average side cost and weight expressed per unit panel area appear in the shaded insert added to the upper right hand corner of Figure 6-14. Both these measures for the side fall between average values for other quadrants. The crown has lower wt./area and \$/area, while the keel has higher wt./area and \$/area. The large size of the side quadrant, combined with the fact that much of the panel is designed by minimum gage requirements, offsets much of the added weight of the passenger door reinforcement and floor elements. Therefore, the weight per unit area is closer to the crown than the keel.

The side quadrant cost per unit area appears related to the observation that much of the side is minimum gage structure with design features similar to a sandwich crown; while the overwing longeron, side quadrant cutouts (door and window), and passenger floor attachments lead to added design complexity over an area roughly the size of the keel. As a result, one may expect the side quadrant to have a cost per unit area close to an average of that for the crown and keel quadrants. Comparing the values listed in Figures 6-12, 6-13, and 6-14, the side cost per unit area is seen to be 1.89 and 0.62 times that for the crown and keel, respectively.

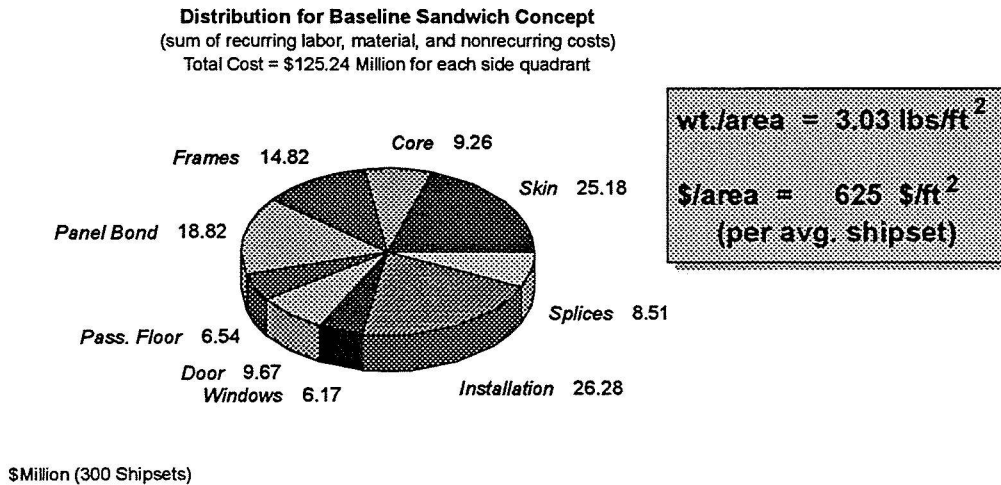

Figure 6-14: Side quadrant cost centers.

6.6 Future Quadrant Considerations

The original definition of the four quadrants (crown, keel, and two side panels) resulted from consideration of the cargo door cutout and a desire to keep the longitudinal splices of these panels from complicating cutout design details. For example the crown-to-side panel splice was placed well above the upper passenger door sill, and the side-to-keel panel splice was placed below the lower cargo door sill. This resulted in uneven sized panels in which the crown was a 90° segment, the two side panels were 118°, and the keel was 34° (ref. 3). At the start of 1992, an ATCAS DBT increased the crown segment to 99°, decreasing both side quadrants to 113.5°, while holding the keel at 34°. This configuration remained baseline through Phase B of the program (see Figure 4-1).

Design experiences from Phases A and B have led the team to further reconsider the definition of quadrant panel sizes for subsequent phases of fuselage development. Several potential changes in quadrant panel sizes have been considered. Most of these are driven by issues identified during keel detailed design. In retrospect, the decision to place the longitudinal side-to-keel panel splice below the lower cargo door was a poor one. The primary issues relate to (a) wheel well and cargo door load redistribution passing through the longitudinal keel-to-side panel splices, and (b) cargo floor attachment at these splices. Both these issues brought forth a desire to increase the keel quadrant size, minimizing load transitions through the longitudinal splice and simplifying cargo floor attachment.

One of the alternate quadrant panel configurations under consideration by the team is shown in Figure 6-15. In this configuration, the keel panel has been increased to the largest quadrant size, moving the longitudinal keel-to-side panel splices such that the right-side splice is close to the mid-point of the cargo door cutout. This location has the advantage of minimizing loads at the splice due to axial load shadows from the cargo door cutout and an increased distance away from major compression load redistribution occurring in the forward keel. The increased keel quadrant size also moves both longitudinal splices away from cargo floor attachments. In the configuration shown in Figure 6-15, the crown and side quadrants are equally sized, providing commonality in tooling.

One of the initial activities anticipated at the start of Phase C will be to re-configure quadrant panel sizes in the ATCAS fuselage section. Several other alternates to the Phase B baseline (Figure 4-1) and that shown in Figure 6-15 will be considered. Other design issues that need to be addressed include interface with systems. The sandwich panel design details that provide some of the system attachments have higher loads than those that have undergone preliminary design in the keel. In addition to the design issues that have been exposed in each of the Phase B quadrants, there are some general issues that need attention by the Phase C DBT considering alternate quadrant configurations. Some of the other items of interest for continued study are: warpage and tolerance control for assembly of full-scale panels; thick facesheet damage tolerance; alternative material and processing options for repair; and nondestructive evaluation (NDE) methods.

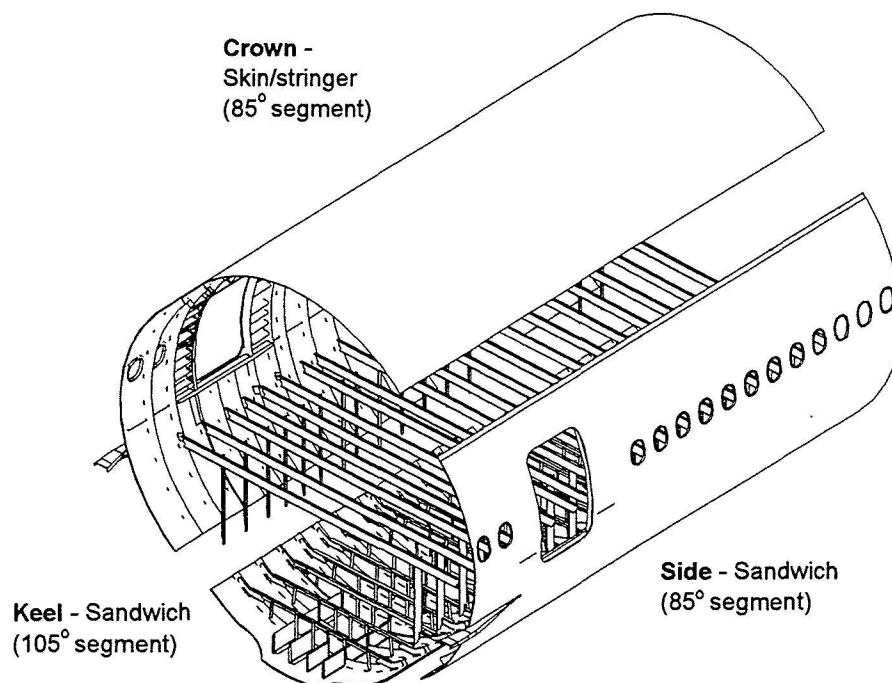

Figure 6-15: Candidate ATCAS Phase C quadrant configuration.

7.0 SYNOPSIS OF TECHNOLOGY DEVELOPMENT

Phases A and B have been focused on integrated technology development of baseline concepts selected for the ATCAS fuselage study section. In order to ensure an integrated technology database, program schedules had to align tasks performed by functional disciplines such as manufacturing and structures. This was achieved, as discussed in Section 4, using an approach that involved DBTs. A large DBT was used for concept selection in each quadrant. Smaller DBTs were assigned tasks in subsequent technology development. Continuous assessments of the total concept value performed by the larger DBT and progress in solving specific technology hurdles pursued by the smaller DBTs were tracked to a critical path schedule. This proved to be an efficient way of monitoring the development of technology which met program goals. It also ensured ATCAS team members had a view of how their contribution affected overall program direction. Section 5 described the baseline concepts, including updates in the designs and manufacturing processes that have occurred as the database expanded since the program start. Section 6 presented the cost and weight of ATCAS baseline concepts at the end of Phase B.

Significant results from the ATCAS program will be highlighted in this section. Results have been broken into five key areas; (1) manufacturing, (2) materials and processes, (3) structures, (4) maintenance, and (5) design cost modeling. A synopsis of the technology developments in each of these areas will be covered in Sections 7.1 through 7.5, respectively. Other ATCAS contractor reports created at the end of Phase B go into greater depth for each of these subjects. These reports will be referenced as needed to abridge discussions.

7.1 Manufacturing

This section highlights major manufacturing achievements that occurred during Phases A and B of the ATCAS program. Manufacturing issues that include quadrant fabrication (Section 7.1.1), precured element fabrication (Section 7.1.2), flexible tooling (Section 7.1.3), and full fuselage section assembly (Section 7.1.4) will all be discussed. Most progress to date, involving some efforts to understand each of these issues, relates to fabrication scale-up for crown, keel, and side panels. This panel fabrication will be covered in Section 7.1.1 (i.e., 7.1.1.1 through 7.1.1.3 for crown, keel, and side, respectively). Manufacturing technology developed for ATCAS is discussed in greater depth by ref. 8.

The ATCAS DBT approach began work in each quadrant with a global cost/weight evaluation of full-scale panels. This resulted in the selection of design concepts and manufacturing pre-plans with potential to achieve ACT goals. The latter included a factory layout of process and assembly cells. Figures 7-1 and 7-2 illustrate the layout used for sandwich side quadrant fabrication and section assembly, respectively. Processing cells in Figure 7-1 include (1) AFP for skin lamination, (2) core blanket fabrication (forming, splicing, and machining), (3) braided/RTM frames, (4) panel subassembly on OML cure tools, (5) autoclave cure, (6) panel trim, and (7) ultrasonic inspection.

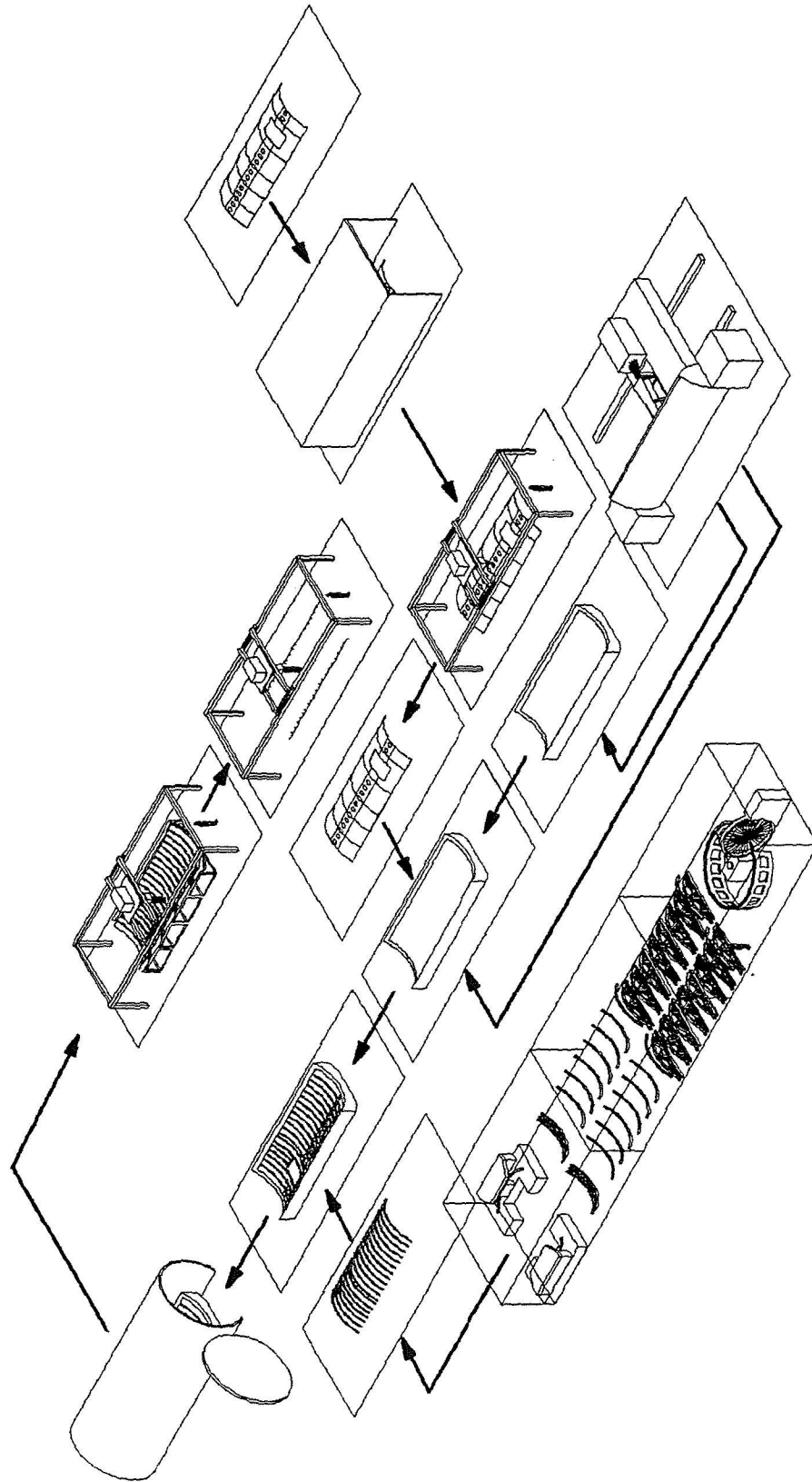

Figure 7-1: ATCAS baseline side panel fabrication cells.

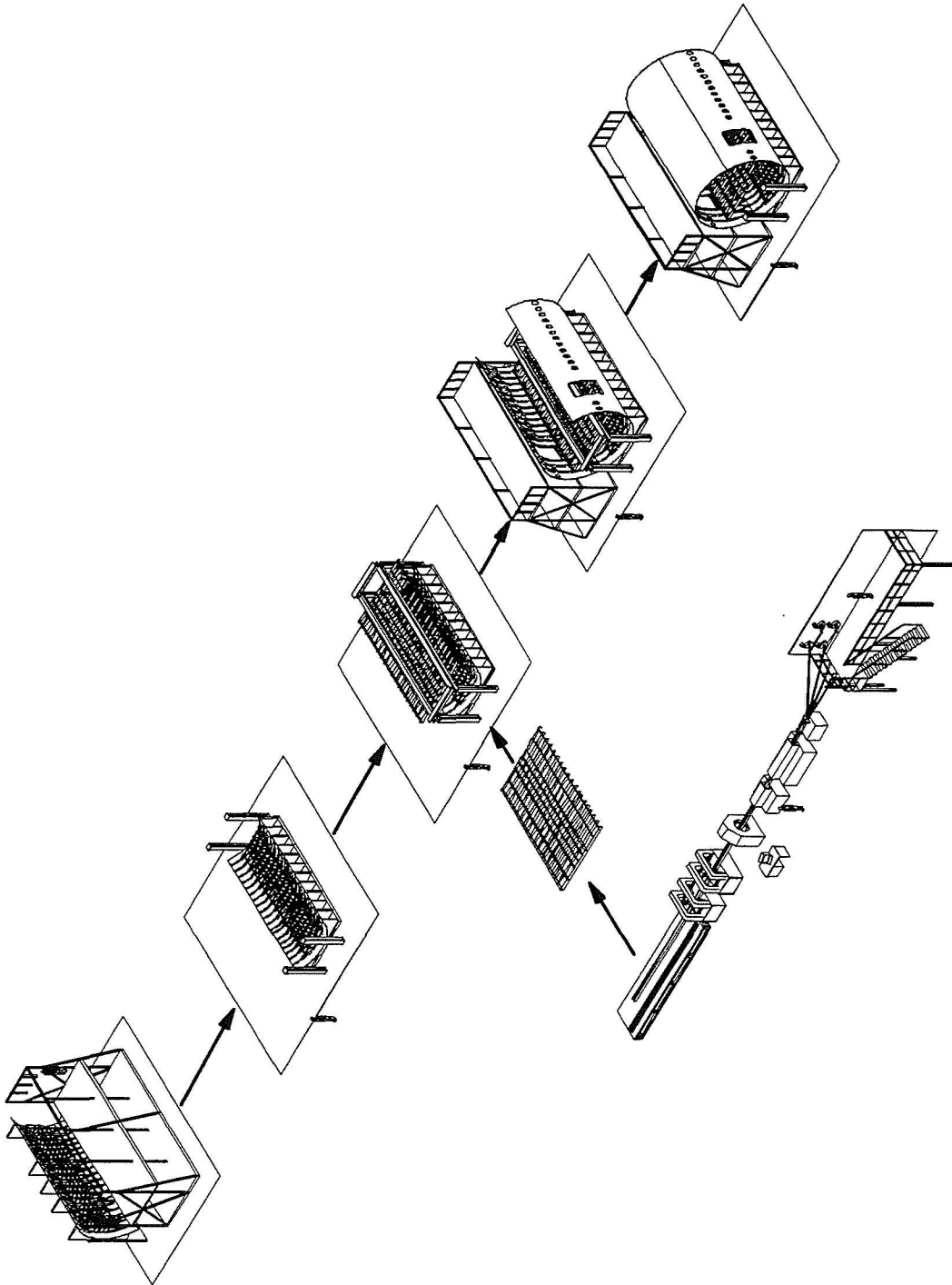

Figure 7-2: ATCAS baseline fuselage section assembly cells.

Cost and weight assessments performed in ATCAS included window, door cutout reinforcement, and floor installation. Only floor installation is evident in the factory schematic shown in Figure 7-2. Also included in cost and weight analyses were fuselage section assembly steps to achieve longitudinal quadrant splices, and circumferential splices to join adjacent body sections. Note that only half of the cost and weight of circumferential splices were added to get totals for the fuselage section. Assembly cells in Figure 7-2 include (1) pultrusion/continuous RTM for floor beams and stanchions, (2) cargo floor installation to the keel quadrant, (3) passenger floor subassembly and installation, (4) side to keel longitudinal splices, and (5) crown to side longitudinal splices.

The vast majority of manufacturing developments performed in Phases A and B of the ATCAS program relate to the fabrication processes shown in Figure 7-1. As discussed in Section 5.1, the largest scale selected for manufacturing demonstration (curved subcomponent panels on the order of 7 ft. by 10 ft) was determined during crown quadrant developments. This panel size appears large enough to adequately demonstrate process steps, tooling, and some tolerance control. Subsequent stages of development will require additional investment in tools to address other important scaling issues.

7.1.1 Quadrant Fabrication

Manufacturing trade studies by the ATCAS DBT suggested that large composite fuselage panels, referred to as quadrants, have potentially lower costs than aluminum technology. This relates to projected cost benefits of AFP and the reduced assembly labor for bonded design concepts (co-cured hat stiffened or sandwich panels with co-bonded frames) and less longitudinal splices (i.e., 4 instead of 10) due to the larger panel sizes. All ATCAS baseline design concepts are relatively stiff bonded structures where tolerance control is essential to achieving the assembly cost savings possible with quadrants. Little payoff is possible from assembly pullup because large forces are needed to distort such structures into shape due to their relatively high bending stiffness. As a result, the as-cured panels must achieve locational tolerance control and dimensional stability (i.e., minimal warpage).

Cost-effective manufacturing techniques with perceived scale-up potential have been aggressively pursued. Several fabrication processes were developed through subscale demonstration panels to corroborate the cost savings potential of ATCAS concepts. Key developments performed at the subcomponent panel scale included:

- (a) AFP for tailored fuselage skins,
- (b) reliable panel cure tooling,
- (c) configured panel process trials, and
- (d) manufacturing tolerance control.

The AFP process has been used to fabricate numerous large contoured skins (Figure 7-3). Related process development efforts focused on controlling laps, gaps, and ply thickness variations, and on attaining high processing rates. AFP machine modifications were identified and implemented to increase lay-up rate and reduce process anomalies. Material width-tolerance variations and tack/impregnation quality were found to significantly

impact lay-up rates. Cure process models were used to develop efficient autoclave cycles that simultaneously cure thick laminates and thin-facesheet sandwich configurations typical of the keel quadrant.

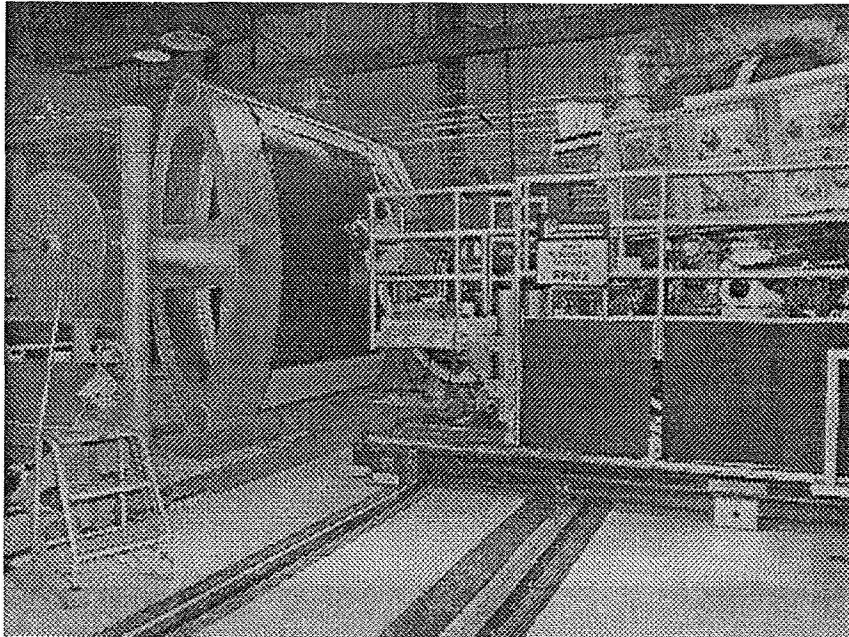

Figure 7-3: *Automated fiber placement of a fuselage subcomponent skin (approximately 7 ft. by 7 ft.).*

Panels have been successfully fabricated using hard OML tooling with semi-rigid IML cauls in both skin/stringer and sandwich configurations. Manufacturing plans developed for cost/weight evaluation of each quadrant included assumed processes for skin-charge transfers and for core machining, forming, splicing and location. During fabrication of stringer-stiffened and sandwich subcomponent panels manual techniques were used for transferring skin charges and handling/locating the core (Figure 7-4). Methods feasible for full-scale parts have been used for core blanket forming, splicing and stabilization. Studies of methods to minimize thickness-tolerance build-up in sandwich structure included core-stabilization techniques that allow accurate machining and core blanket handling, and eliminate core movement during panel cure.

Most configured panels fabricated to date were extensively inspected for panel warpage and element locations (e.g., Figure 7-5). Movement of cobonded frames on skin/stringer and sandwich panels has been observed, and is likely related to thermal and chemical shrinkage and out-of-plane displacements caused by the cobonded elements settling into the skin. Finite element (FE) modeling techniques for predicting panel warpage identified edge variation, tooling, process control, spring-in at stiffening element radii, nonlinear effects (geometric & material), and thermal mismatch between bonded elements as major contributors to the observed behaviors (ref. 38). Analytical extension of subscale results to full-scale quadrants is needed in subsequent phases of development to support assessment of critical panel bond assembly requirements and barrel assembly methods.

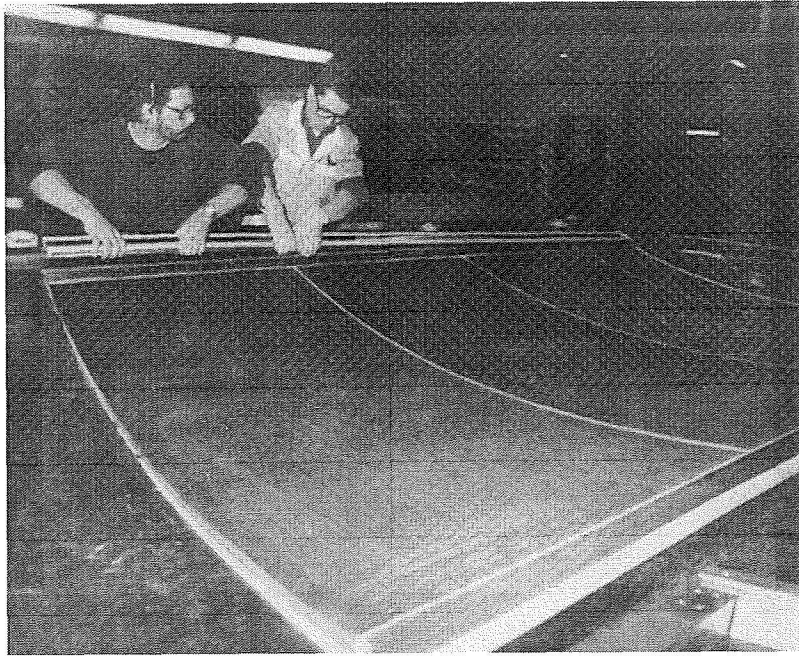

Figure 7-4: *Manual keel panel subcomponent assembly.*

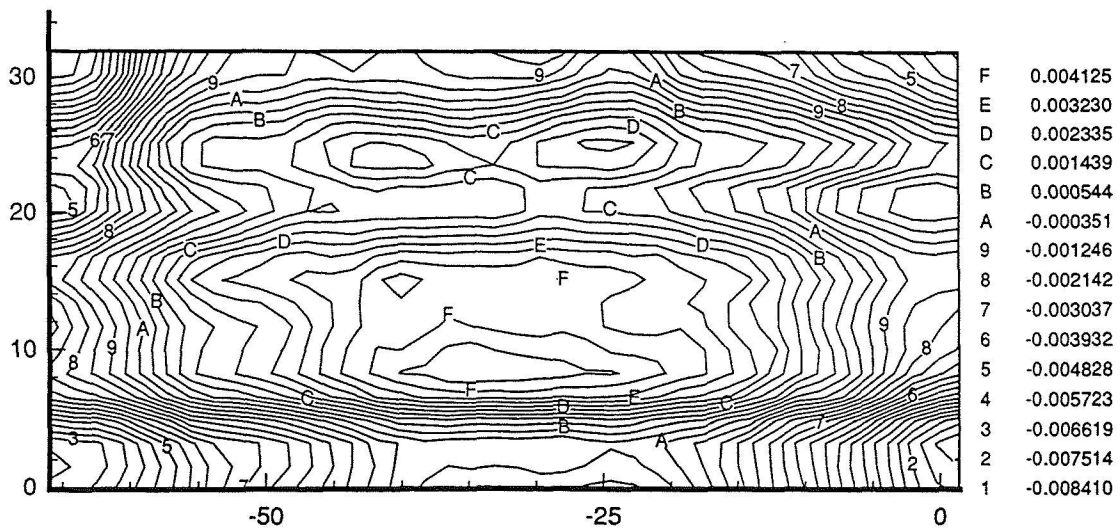

Figure 7-5: *Measured out-of-plane deformations of a forward keel subcomponent resulting from cure-induced residual stresses (all dimensions are inches).*

7.1.1.1 Crown Panel Scale-up

As discussed in Section 5.1, the ATCAS DBT selected a hat-stiffened skin with cobonded frames for baseline manufacturing development in the crown quadrant. The baseline material used for skin and stiffeners was AS4/938. Skins were laminated using AFP. The AFP process allowed cost-effective fabrication of intraply hybrid (graphite/fiberglass) skins in which each ply in the laminate had a repeatable pattern of AS4/938 and S2/938 tows. As discussed in the next subsection, this material form proved to have superior damage tolerance. The hat-stiffeners were drape-formed from flat tow- or tape-placed laminates and cocured to the skin using elastomeric tooling inserts. Braided frames were fabricated in a batch RTM process and machined to include stringer mouseholes for bonding to the panel during final cure. An OML cure tool plus low-cost inner mold line (IML) tooling aids and a reusable cure bag were utilized for final panel fabrication in an autoclave. A limited number of crown panels were fabricated with bolted frames instead of bonded frames as alternates to the baseline concept.

In addition to Boeing, Hercules Structures (now Alliant Techsystems), and Fiber Innovations played important roles in the crown process development. Figure 7-6 shows one of nine large crown manufacturing demonstration panels that were fabricated in 1991 and 1992. Funding to fabricate five of these panels came from another NASA contract that has supported ATCAS development, Boeing's NAS1-19349 (ref. 7). The AFP, panel subassembly and autoclave cure for all nine large crown panels was performed at Hercules (subcontracts to Boeing and Hercules' NAS1-18887). Fiber Innovations fabricated more than 50 braided/RTM frames with lengths up to 8 feet to support this effort.

Significant efforts were spent in early crown concept development to integrate design and manufacturing process details. A DBT was assigned to solve problems uncovered in the initial crown panel fabrication scale-up trials. These included cured panel anomalies (e.g., stiffener cross-sectional distortions, porosity, and delamination), warpage, stiffener mandrel entrapment, and tooling problems. Detailed accounts of the design and process solutions successfully obtained by this crown DBT was documented in ref. 9.

A complete assessment of crown manufacturing development was covered in refs. 8 and 34. The crown manufacturing database includes recommended tooling approaches, optimized process steps, and cured panel dimensional tolerance data (thickness, warpage, and element location). Much of the focus for design cost model development came in the evaluation of crown manufacturing technologies. Cost studies have been performed to calibrate relationships between crown design details and manufacturing steps (see refs. 10, 14, and 37 for additional summaries on the ATCAS cost database). Despite the pursuit of hat-stiffened designs, many crown process steps are similar to those in manufacturing plans for sandwich keel and side panels.

A number of manufacturing hurdles need to be resolved prior to further manufacturing scale-up of the baseline crown design. Based on dimensional tolerance data collected and analysis performed to date, tooling correction factors will be established to minimize assembly costs. Material and process controls must be established for the AFP skin and braided frames. Inspection standards are also needed to evaluate critical bondline areas.

Skin fiber distortions and element sinkage (strongest for precured frames) have been observed near the skin intersection with bonded frame and stiffener elements. The effect of these process defects on structural performance must be understood or cure tooling enhancements that minimize their occurrence need to be developed. As discussed earlier, mouseholed bonded frames are potentially structurally inadequate for a hat-stiffened skin, and alternate bolted frame or sandwich concepts will be considered for the crown panel.

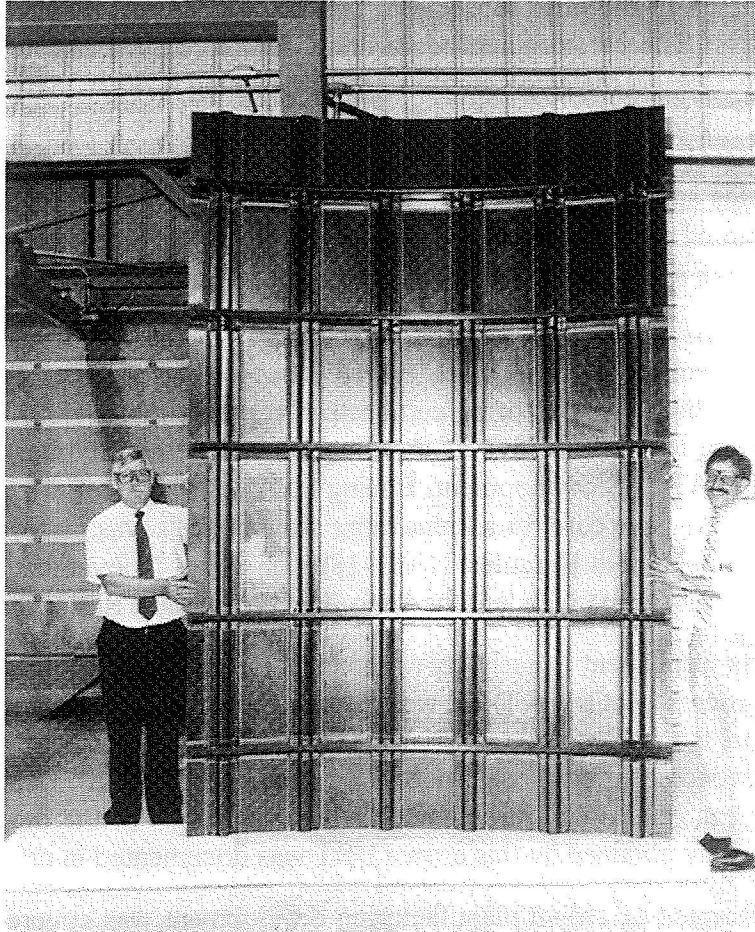

Figure 7-6: Crown manufacturing demonstration (7 ft. x 10 ft.)

7.1.1.2 Keel Panel Scale-up

As discussed in Section 5.2, an innovative sandwich concept was selected as baseline for keel panel manufacturing development. The conventional metal design, that included two large keel beam chords to carry fuselage compression loads through the wheel well cavity area, was replaced by a "panelized keel chord" design concept that was more cost- and weight-effective for composites. As axial loads redistribute moving aft of the wheel well, the composite keel panel transitions from thick laminate to sandwich, while maintaining constant OML and IML surfaces. Braided/RTM frames that are cobonded to the sandwich panel were also selected for the keel quadrant. Pultrusion was chosen for most elements that support the cargo floor.

Load transitions, penetrations, attachments, and cargo floor installation make the keel quadrant a much more difficult manufacturing challenge than the crown. Alliant Techsystems (formerly Hercules Structures) supported the development of efficient and accurate AFP add/drop capabilities needed to laminate tapered skins in the forward keel. Splicing, forming, and machining process steps for high-density core were developed at Boeing. A relatively low-pressure autoclave cure cycle and tooling for processing panels that transition from thick laminate to sandwich was developed by Boeing with technical support from Hercules (AS4/8552 material), Intec, and universities. The same OML cure tool used for the crown was also used for keel sandwich panel fabrication. The Lockheed ACT program (NAS1-18888) developed braided/RTM frames which were cobonded to the ATCAS sandwich panels. Development work was also performed for sandwich panel edge close-outs, including efforts by Boeing, Fiber Innovations, and Intec.

Large manufacturing demonstration panels were successfully fabricated for aft, mid, and forward areas of the keel quadrant (refs. 28 - 30). Significant efforts were spent in early aft keel concept development to study sandwich fabrication issues for core processes (forming, machining, splicing and stabilization), edge design details, and the cure cycle. These problems were solved for the minimum-gage aft keel by the end of 1993.

Prior to fabricating the curved panels for the mid and forward keel, several flat panels (see Figure 7-7) with thick-laminate-to-sandwich transitions were processed to verify the low-pressure cure cycle developed for keel design details (ref. 13). Micrographs shown in Figure 7-7 are indicative of the high quality panels fabricated using the AS4/8552 material and the ATCAS cure cycle. This major ATCAS technical achievement, which included the selection of a material with robust processing traits and validation of a suitable cure cycle, helped give the DBT confidence to pursue sandwich for the side quadrant.

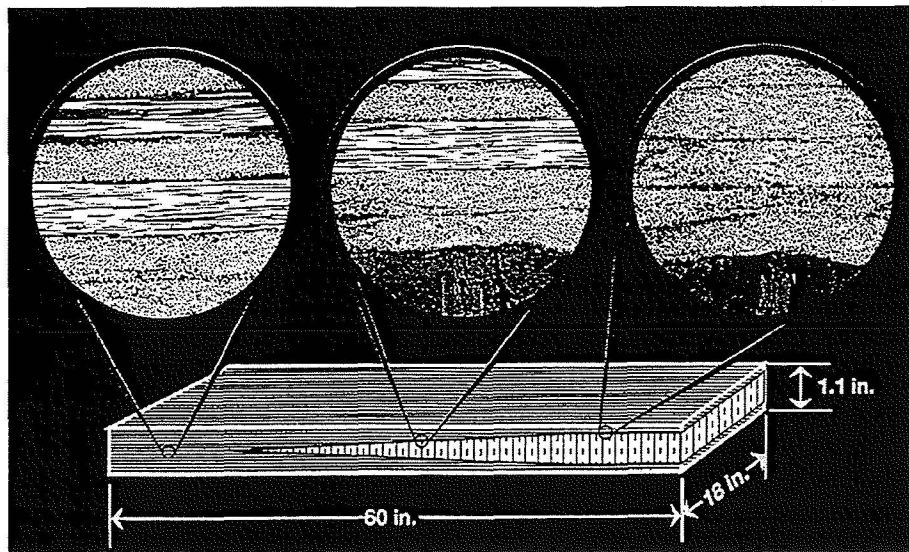

Figure 7-7: Keel cure cycle development trials.

7.1.1.3 Side Panel Scale-up

Manufacturing developments for the sandwich side quadrant did not begin until 1994; however, complementary efforts in the keel were active since 1992. The side quadrant has several unique manufacturing issues in addition to those being addressed for the keel. These include skin panel and framing element fabrication developments related to door and window cutout design details. The process control of locational tolerances and warpage for the large (22 ft. x 32 ft.), highly tailored, sandwich side panel is also crucial to passenger floor installation and barrel assembly. Significant point to point variations in loads and design drivers throughout the large side quadrant make this a difficult task. The goal is to develop a comprehensive understanding of which structural details can achieve the desired producibility at an affordable total manufacturing cost.

Phase B manufacturing demonstrations for the side quadrant were limited to configured window-belt panels and door framing elements in ATCAS Phase B (refs. 27, 29, and 30). Figure 7-8 shows an ATCAS window-belt panel which was machined and prepared for pressurebox testing at NASA Langley. Baseline materials for the sandwich side panel included Hercules' AS4/8552 for the skin and DuPont's Korex for the core. As discussed, the former was also used in keel developments. Trade studies selected the lower density Korex core material for side developments due to significant weight savings with minimal cost increase (ref. 22). This selection led to additional core forming and machining process developments to support the side (ref. 30).



Figure 7-8: Side manufacturing demonstration (7 ft. x 10 ft.).

In addition to braided/RTM circumferential frames, Lockheed supplied Boeing with window frames and also pursued an alternate window-belt sandwich design concept through their NASA contract (NAS1-18888, refs. 23 - 26). Boeing evaluated OML tooling and the full-depth window cutout design concept shown in Figure 7-8 (including a braided/RTM window close-out, ref. 33), while Lockheed pursued IML tooling and a ramped down window cutout in collaborative efforts. These joint developments allowed the fuselage side DBT to directly compare the producibility of key design variations in

panels up to 7 ft. x 10 ft. Details of this evaluation, including implications to subsequent phases of the ATCAS program, are provided in ref. 8.

Manufacturing developments for the passenger door structure were addressed in the form of fabrication trials for braided/RTM edge frame elements at Northrop/Grumman. Figure 7-9 shows the design configuration selected with representative complexity for these trials. This element features variation in web and chord flange thickness necessitating variation in the triaxially braided preform architecture as indicated in Figure 7-9. Details on this developmental effort are also contained in ref. 8.

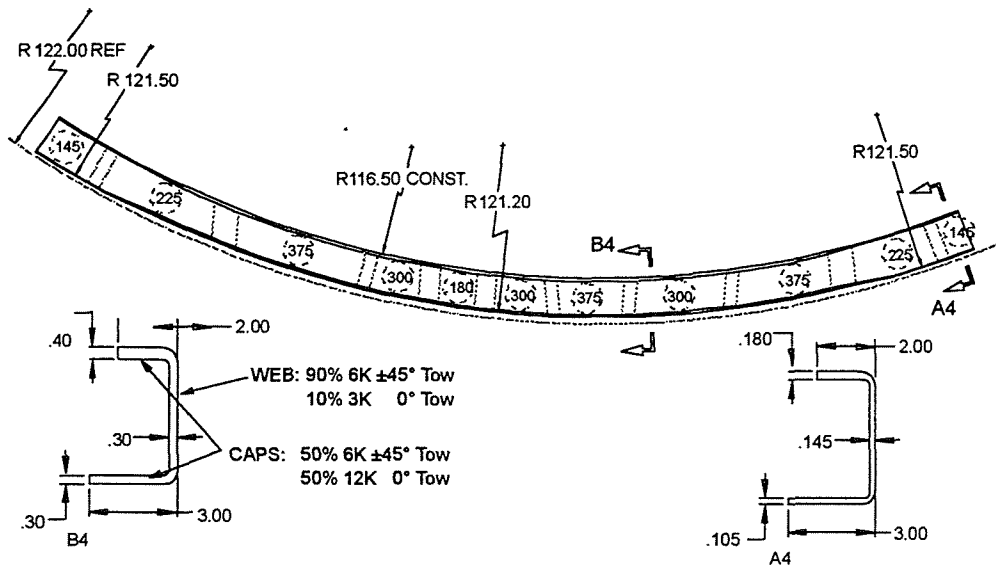

Figure 7-9: Configuration for Northrop/Grumman manufacturing demonstration of a passenger door edge frame.

7.1.2 Precured Element Fabrication

Detailed cost studies of manufacturing methods to produce precured primary structural elements identified pultrusion and RTM of textile preforms as having cost saving potential. Candidate fuselage elements for pultrusion processes include passenger and cargo floor beams, intercostal attachment chords, and cargo floor stanchions. Candidate elements for textile/RTM processing include circumferential frames, window frames, passenger door cutout reinforcement members, and sandwich close-out elements. Companies involved in process development for various braided/RTM elements used by ATCAS included Lockheed (NAS1-18888, refs. 23 - 26), Fiber Innovations, Northrop/Grumman, and Boeing (NAS1-18889, NAS1-20013, NAS1-19349, & NAS1-18954).

The RTM process using braided fiber preforms for circumferential J-frames was developed for subscale crown, keel, and side panel configurations (Figure 7-10). Preform fabrication and cure processing developed for these frames demonstrated part repeatability suitable for structural applications. Fabrication cost and part quality measurements were found to support initial cost trade study findings (ref. 10). Future advancements in braided/RTM processing should include cost-effective tailoring of frame cross-sections (e.g., Figure 7-9) and, hence, the ability to compete with high-speed machining of equivalent metal parts.

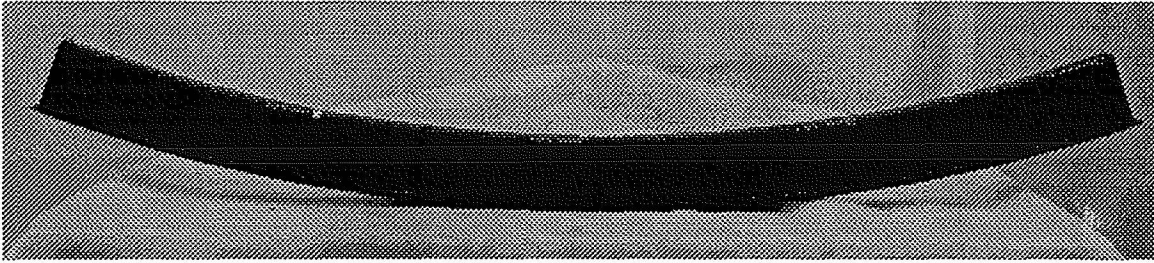

Figure 7-10: Braided/resin transfer molded circumferential frame (approximately 8 ft. long).

RTM technology was also used to successfully fabricate elements for full-depth sandwich panel edge close-outs, both at splices and window cutouts. Good tolerance control has been achieved in splice close-outs fabricated to date. Sandwich panel window close-outs, such as those shown in Figure 7-11, have been fabricated using S-2 glass or AS4 carbon fiber braided in a 2-D triaxial architecture over syntactic foam filled honeycomb mandrels. References 8 and 11 provide additional details on precurred element fabrication.

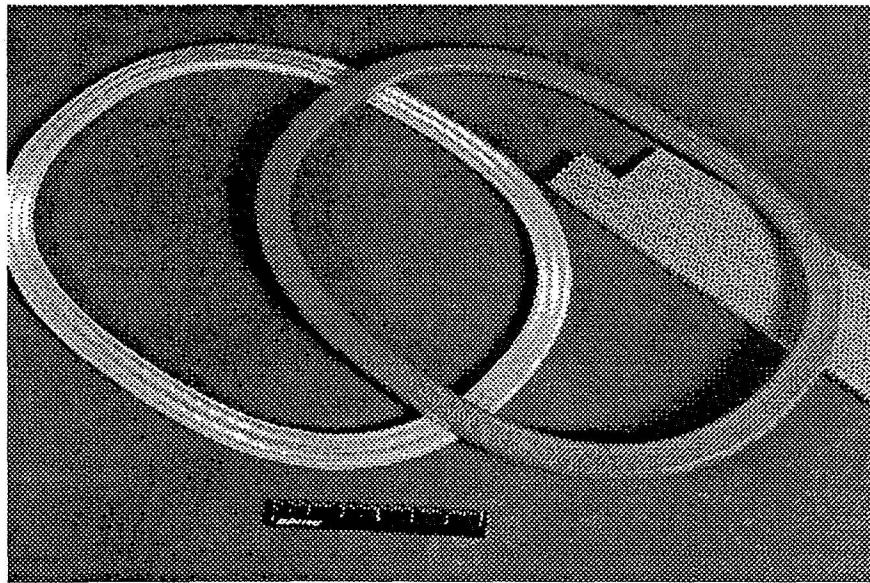

Figure 7-11: Braided/resin transfer molded window close-outs.

7.1.3 Flexible Tooling

The OML cure tool approach pursued by Boeing throughout Phase A/B allows panel thickness changes without violating OML aerodynamic shape constraints. Semi-rigid IML caul plates were used in combination with this approach to control resin flow and thickness variations (Figure 7-12). This technique successfully addressed several design variations during subscale manufacturing demonstrations of both skin/stringer and sandwich configurations, with minimal impact on tooling cost. A rigid IML cure tool concept was pursued by Lockheed for a sandwich window-belt panel (under their ACT Phase A/B funding) in order to (1) exploit element locational-control potential and (2) evaluate the flexibility of this alternate tooling approach.

Although assembly tooling has not been specifically addressed, element location tolerances were measured for subcomponent panels. Significant shrinkage was observed on these panels; however, the panel-to-panel shrinkage variations were not great. More work is needed to ensure that assembly tooling addresses the magnitude and variations in element location and other requirements related to design modifications.

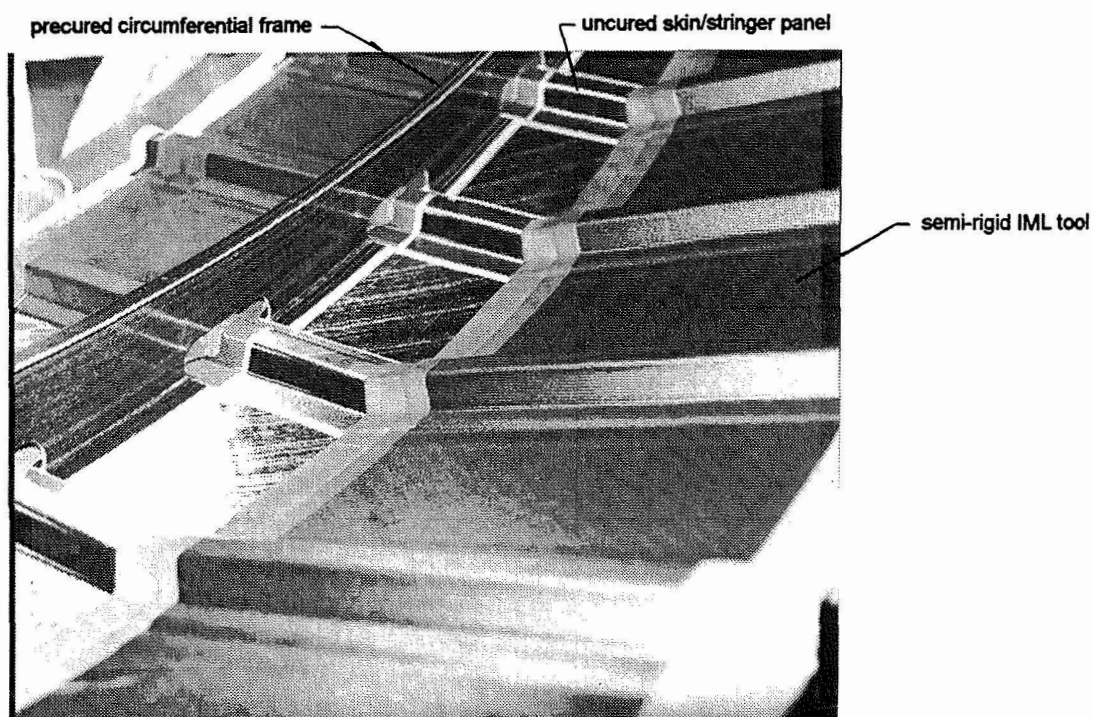

Figure 7-12: *Semi-rigid IML caul plates used to control resin flow and thickness variations in crown panel subcomponents.*

7.1.4 Full Barrel Assembly

Manufacturing development for fuselage section assembly received limited attention in Phases A/B due to evolving quadrant designs. Splice designs were considered during quadrant design development, as were assembly cost components (e.g., shimming, drilling, fastener installation). Assembly issues were included in a manufacturing process study conducted for each quadrant panel, identifying high labor content, shimming, and inflexible tooling as significant cost elements. Panel warpage and element location data collected during Phase A/B panel fabrication were evaluated to support prediction of full-scale assembly pull-up forces and tooling cost assessments.

7.2 Material and Processes

This section summarizes major ATCAS achievements on issues that closely associate an understanding of materials and processes. The focus will be on those materials and processes considered baseline and/or scaled in significant manufacturing demonstrations

for Phases A and B of the program. Technology for several advanced materials and processes pursued during the course of the program did not advance to a level of maturity that would allow them to be considered in major hardware. A more complete documentation of ATCAS material and process studies, including most of those evaluated at some point in the program can be found in ref. 11.

7.2.1 Tension Strength versus Toughness Trades

At the start of ATCAS, very little information existed to support the design of composite structures with large damage sizes (i.e., required for damage tolerant design practices, including consideration of discrete source issues). A large database has been collected in ATCAS on composite notch sensitivity (tension and compression) and structural residual strength (ref. 39). The data and supporting analyses have led to some understanding of material, laminate, structural, and manufacturing variables crucial to damage tolerant design. Subsequent studies are required to quantify the effects of combined loads (including compression, shear, and pressure), dynamic pressure containment, and additional damage scenarios.

The damage tolerance issues for approximately 70% of a typical wide-body commercial fuselage (minimum gage) are dominated by pressure. Other fuselage areas depend on axial tension load cases and corresponding damage tolerance issues. Sufficient tensile residual strength is required to meet the associated design goals in these fuselage areas. Figure 7-13 shows tensile residual strength curves plotted from small and large notch data for alloys used in aluminum fuselage and for composite laminates studied in ATCAS.

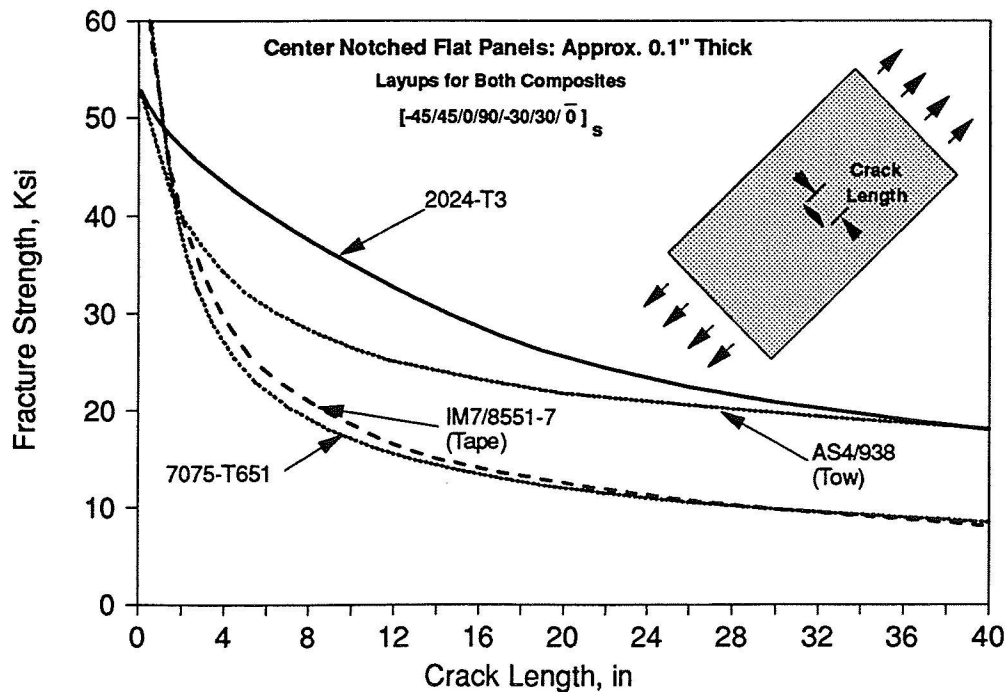

Figure 7-13: Tension residual strength curves for aluminum and composite materials.

A large database supports the metals curves shown in Figure 7-13, while ATCAS residual strength tests for IM7/8551-7 tape and AS4/938 tow-placed laminates include notch sizes up to 12 in. (refs. 40 and 41). A strength versus toughness trade is apparent in both classes of materials. For example, 7075-T651 and IM7/8551-7 both have high undamaged strengths but lower fracture toughness (i.e., greater notch sensitivity as shown by the rate of decrease in residual strength with increasing notch size) than the other two materials. The lower toughness relates to the small damage zones that occur at a loaded notch tip in 7075-T651 and IM7/8551-7 and the resulting inability to relieve local stress intensity.

The 2024-T3 aluminum in Figure 7-13 gets its relatively high fracture toughness from crack tip yielding (i.e., plasticity), while AS4/938 gets relief from the notch tip stress intensity through other mechanisms such as fiber breakage and delaminations. These same mechanisms lead to relatively low small notch strengths for both 2024-T3 and AS4/938. This phenomenon, referred to as fracture resistance in metals, depends on crack length and specimen size. The curve for AS4/938 has a different shape than that for 2024-T3. This is likely due to a differing relationship between composite local failure and panel width. Such composite stress relief mechanisms also mask a high fracture toughness until tested with larger notch and panel sizes. Lower tensile residual strengths with large damage for IM7/8551-7 tape and a relatively hard layup indicate composites that resist some modes of matrix damage (often referred to as "tough") may not be suitable for fuselage skins.

Figure 7-14 shows the tensile strength versus toughness property trades for several other metals considered in fuselage structures and some composite laminates tested during ATCAS. The X-axis in Figure 7-14 plots two measures of tensile strength (yield for aluminum and open hole tension for composite), while the Y-axis plots the effective fracture toughness determined from tests and analysis for large notches (thin plate K_C for aluminum and translaminar K_C for composite). Both composite laminates and aluminum alloys tend to follow a tensile strength versus toughness trade in which materials with the highest strength also tend to have the lowest toughness and vice versa. Due to differing failure modes, the translaminar fracture toughness shown in Figure 7-14 does not directly correlate with the interlaminar fracture toughness used in delamination analysis.

Analysis methods used by ATCAS to extrapolate from the largest notch tested (ranging from 2.5 in. to 12 in.) to the effective K_C in Figure 7-14 for a 20 in. notch are described in several references (refs. 6, 7, 11, 17, 38, 39, 40, 41). Data trends for most composite laminates showed linear elastic fracture mechanics to be inaccurate for scaling small-notch results to sizes critical for damage tolerance evaluations. Some improved correlations were obtained for a wide range of notch lengths using semi-empirical laws based on reduced singularities and R-curve approaches. The most promising analyses for predicting a wide range of notch sizes and specimen geometries, while still having practical use in the simulation of structural configurations, were based on a strain softening model of notch tip damage growth. Strain softening material laws in conjunction with nonlinear FE modeling predicted the ATCAS experimental data trends by simulating the growth of a reduced-stiffness damage zone and resulting load redistribution. The unloading curve for strain softening infers significant notch-tip fiber failure occurs before structural collapse, a pre-catastrophic failure mechanism which was confirmed by de-ply experiments.

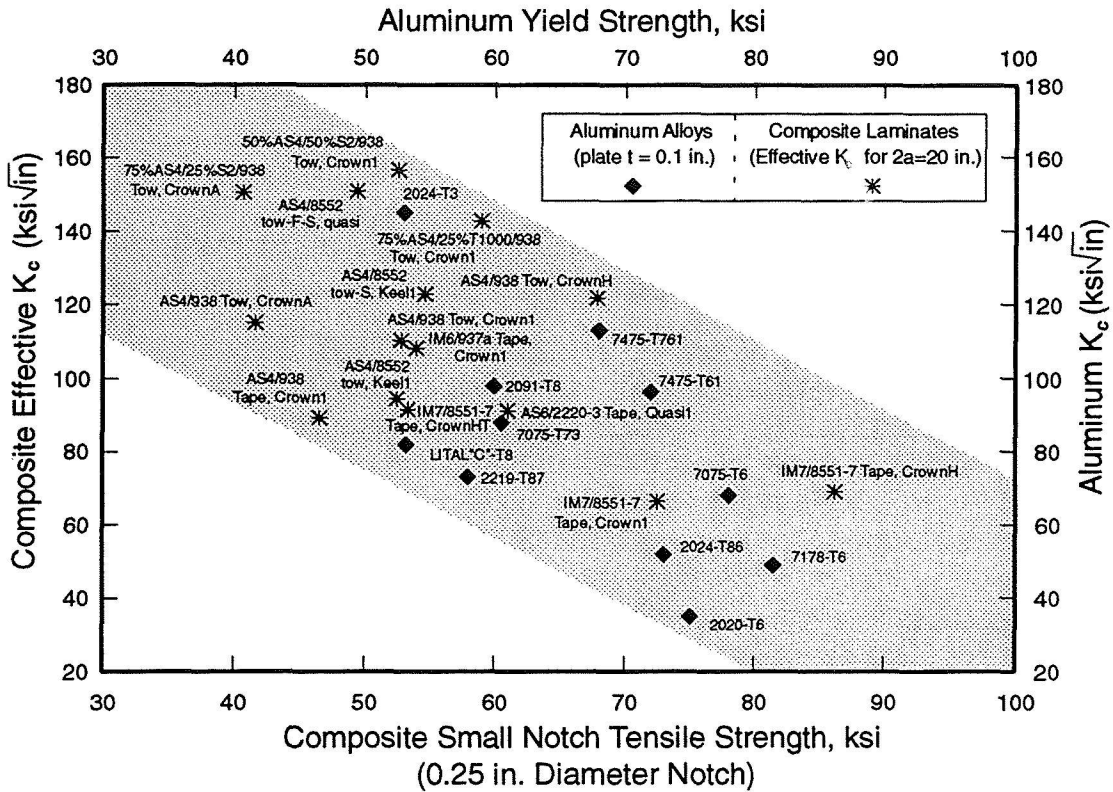

Figure 7-14: Tension strength versus toughness trades for metals and laminated composites.

Specific material, process, and layup identities were established for each point plotted in Figure 7-14 due to the myriad of factors that were found to affect the tensile fracture properties of laminates tested during the ATCAS program. Fabrication processes used for lamination (see Section 7.2.4) were found to have a strong effect on both static and high-rate tension fracture performance. Intraply hybridization with fiberglass or higher strain-to-failure graphite prepreg tow was also found to provide a 20 to 30 percent increase in tension fracture performance. Other factors found to be important included fiber type, matrix type, sandwich construction, and surface fabric layers.

As an example of the complex interactions affecting tensile fracture performance refer back to Figure 7-13. An axially-stiff layup for a material with a brittle matrix yields significantly greater large notch strength (and effective fracture toughness) than does the same layup used for a material with a toughened matrix and higher strain-to-failure fiber. However, the transverse (soft) direction of the same layup yields uniquely different trends when comparing residual strength curves for the same two materials. Synergistic effects such as these resulted in designations (identifying the specific material, process, and layup) analogous to those applied to distinguish unique characteristics of aluminum alloys (e.g., % constituents, heat treatment). An overall comparison of trends seen in the ATCAS database did yield some insights for predicting the effects of layup in preliminary design. However, residual strength analyses supporting damage tolerant design and maintenance will likely require data for specific details of the material, process, and layup.

7.2.2 Compression Residual Strength

Compression notch sensitivity data is most critical to keel and side quadrant design. As a result, data collected in ATCAS has been limited to sandwich panels. Unlike tension, the compression notched strength has been found to have much less dependence on material, laminate, structures, and manufacturing variables (ref. 11 and 39). Figure 7-15 shows average compression notched strength results for sandwich panels with different facesheet materials, core types, and a wide range of laminate layups (with and without fabric surface plies). The majority of data is for facesheet thicknesses on the order of 0.09 in. In stress space, most of the data tends to clump in a band, suggesting little difference in notched compression properties. The only exceptions are data points for sandwich panels with facesheet thickness increased to 30 plies (0.22 in.).

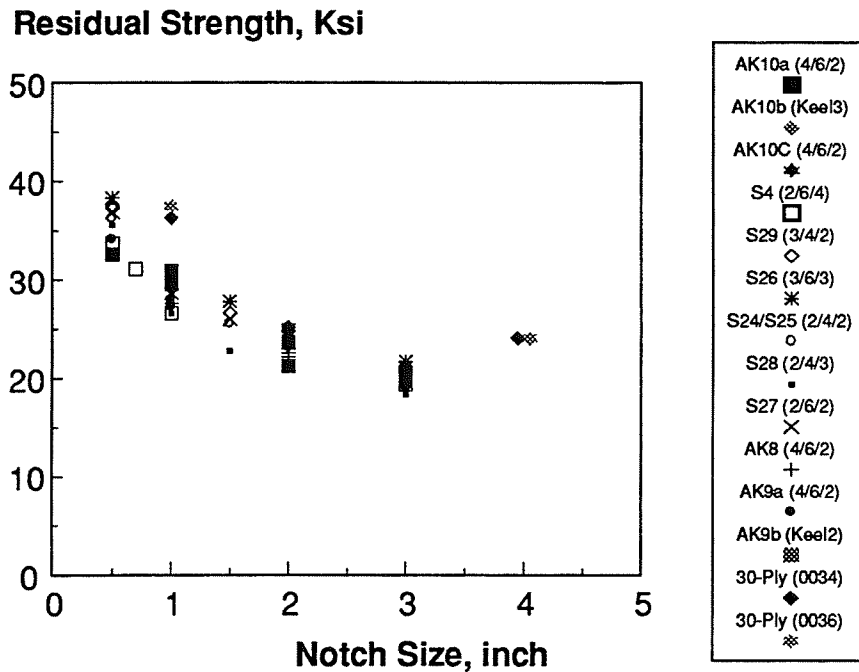

Figure 7-15: ATCAS compression notched strength results.

Additional compression notched strength data available at Boeing (including solid laminates) has also shown trends similar to those in Figure 7-15. As shown schematically in Figure 7-16, the strongest effect on compression notched strength appears to be laminate thickness. Failure of notched laminates having distinctly different stiffness at the same stress level indicate that an increased percentage of angle plies (i.e., ± 45) result in greater global strain to failure. As is the case for crippling, this behavior may suggest a compression failure mechanism driven by local stability. Another indication that local stability is the dominant mechanism comes from the observation that matrix toughness has little or no effect on the notched compression strength.

Compression notch sensitivity has not been reported as an issue for metal, presumably due to lack of problems with local instability (e.g., no fiber kinking mechanism). As a result,

allowable stresses increase significantly for aircraft structures subjected to high compression loads (e.g., forward areas of ATCAS keel quadrant or upper surface of a transport wing). In order for composite materials to compete with 7000-series aluminum alloys in such applications, the improvements in notched compression strength with increased laminate thickness must be quantified for design. In addition to the thickness effect shown in Figure 7-16, other factors likely to affect local stability (e.g., environment and notch geometry) need to be evaluated in subsequent phases of ATCAS.

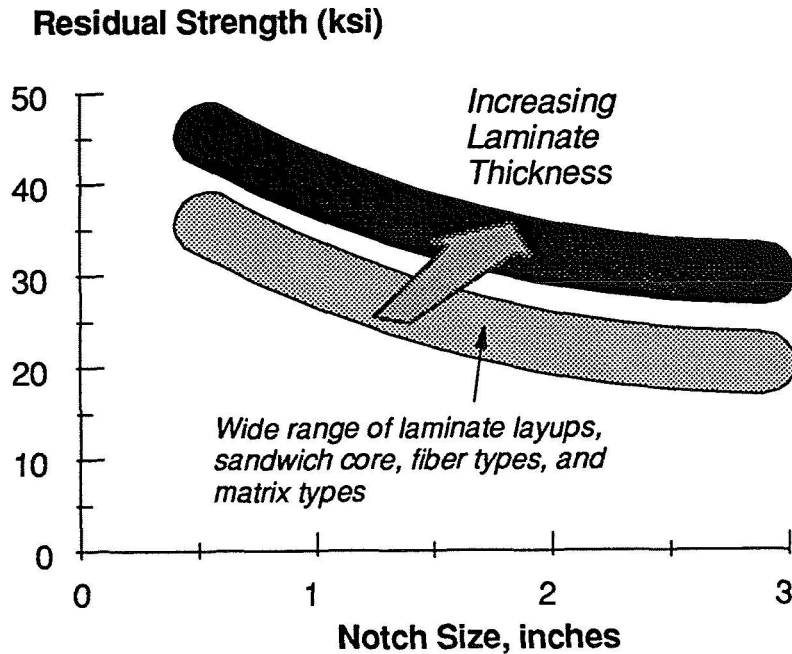

Figure 7-16: Compression notch sensitivity.

Reference 6 summarizes other ATCAS studies that showed both post-impact and notched compression residual strengths can be analyzed using a similar approach. The primary difference comes in the additional steps needed to characterize changes in the local stress concentration due to impact damage (e.g., sublaminar stability and local load redistribution). Nondestructive evaluation (NDE) procedures, used in ATCAS to quantify the effects of arbitrary impact damage found in service, are discussed in Section 7.4.

Strain softening analyses have been successfully extended to compression of sandwich structure with single-face impact damages and notches through both facesheets (ref. 38). As one might expect, based on unique failure mechanisms in composite laminates, the strain softening laws used for compression are distinctly different than those used for tension (refs. 6 and 11). The same has been found for other materials (e.g., ref. 42). Figure 7-17 shows that interactions between local softening, stability and impact damage growth were predicted. The combined experimental database and analysis scaling laws should enable accurate compression residual strength predictions needed for damage tolerant design and structural repair manuals. This will also be discussed in Section 7.4.

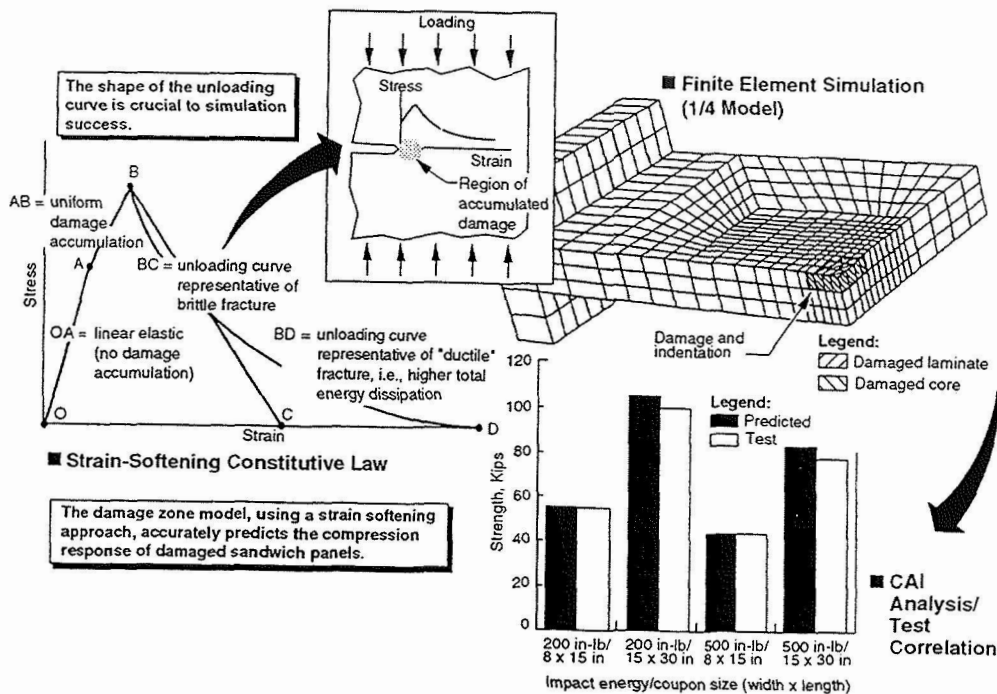

Figure 7-17: Finite element simulations of sandwich post-impact compression tests using a strain softening approach.

7.2.3 Bolted Joints Evaluations

Although structural subcomponent tests were not performed in ATCAS Phases A and B, bearing/bypass properties of candidate skin materials were characterized and some critical splice element tests were performed. Details of these test results and supporting analyses can be found in ref. 11.

Bearing/bypass test results for AFP laminates were found to be close to those obtained previously for tape laminates. A strong correlation between the bypass strain-at-failure and linear-elastic stress concentration factor was observed. Bearing strength was found to be independent of layup. Some intraply hybrids were found to exhibit an inhomogeneous bearing/bypass response dependent on the bolt hole location. Unique properties were also observed for braided/RTM architectures used in ATCAS framing elements.

Predictions of uniaxial bearing/bypass strength were consistent with test results for tension bearing/bypass interactions. Transverse-bearing/compression-bypass strength predictions were found to be conservative. This likely relates to the use of open-hole (instead of filled-hole) compression strength for the bypass failure criteria.

Initial studies on the bolted joint performance of candidate sandwich core close-out design concepts were also performed. Adequate performance was obtained, but future efforts should be able to identify more optimal design details.

7.2.4 Material and Process Control

Significant experience with cost-effective composite processes has resulted in an understanding that will support future process control efforts. A considerable manufacturing and test database for AFP was generated using several prepreg tow materials, each of which was procured at various stages in the development of the fiber prepregging process. Key prepreg tow material attributes believed to affect part manufacturing cost and performance were identified. Significant process-induced performance traits were observed in many of the test panels fabricated using AFP, demonstrating the need for process control. Figure 7-18 provides an example of such differences seen in the tensile fracture performance. The fiber type, matrix type, % constituents, and laminate layup are the same for all results shown in this figure. The main difference is in using AFP or hand-laid tape for laminate fabrication. Note that the most significant differences in Figure 7-18 are not evident until notch sizes greater than one inch. The pulse-echo amplitude map shown in Figure 7-19 for a configured crown panel fabricated using AFP indicates repeatable skin variations which may be responsible for improved fracture properties.

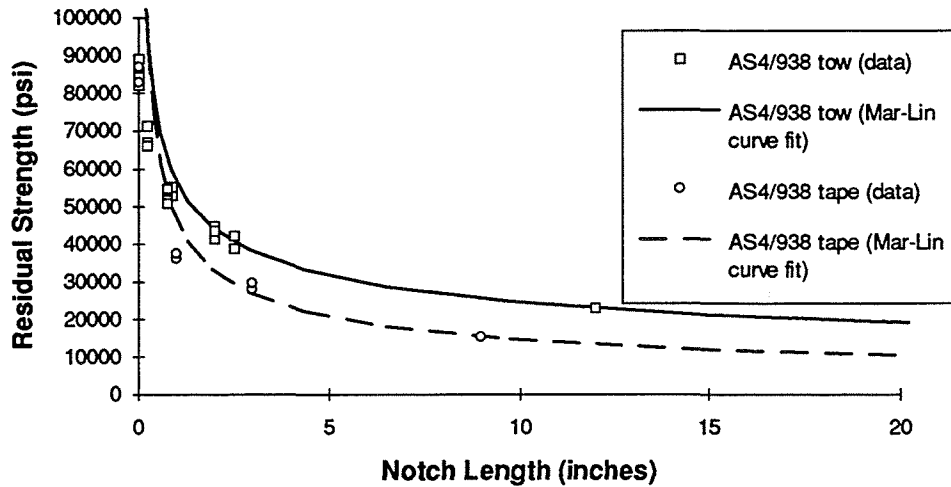

Figure 7-18: Results of notched tension tests on AFP (tow) and tape laminates of the same nominal material.

Intraply hybrid laminates and braided materials considered in ATCAS applications are shown on the left and right sides of Figure 7-20, respectively. These material forms have been found to have unique attributes for transport fuselage structure, including reduced notch sensitivity. These improved properties are not clearly evident in small coupon tests because the area for load redistribution is insufficient, leading to strong size effects. Figure 7-20 lists some of the other benefits and challenges of these materials. It is crucial to realize that specific attributes may (1) allow changes in requirements and (2) minimize issues for implementing such materials into production. For example, factory inspection procedures commonly used for tape laminates apply relatively high ultrasonic frequencies (e.g., 5 MHz) to detect small defects. These high frequencies interpret the inhomogeneity in intraply hybrids and braided materials as defects (see the ultrasonic scan of a hybrid laminate with center impact in the lower left corner of Figure 7-20). However, the

reduced notch sensitivity of these material forms provides confidence to use lower frequency ultrasound for inspection.

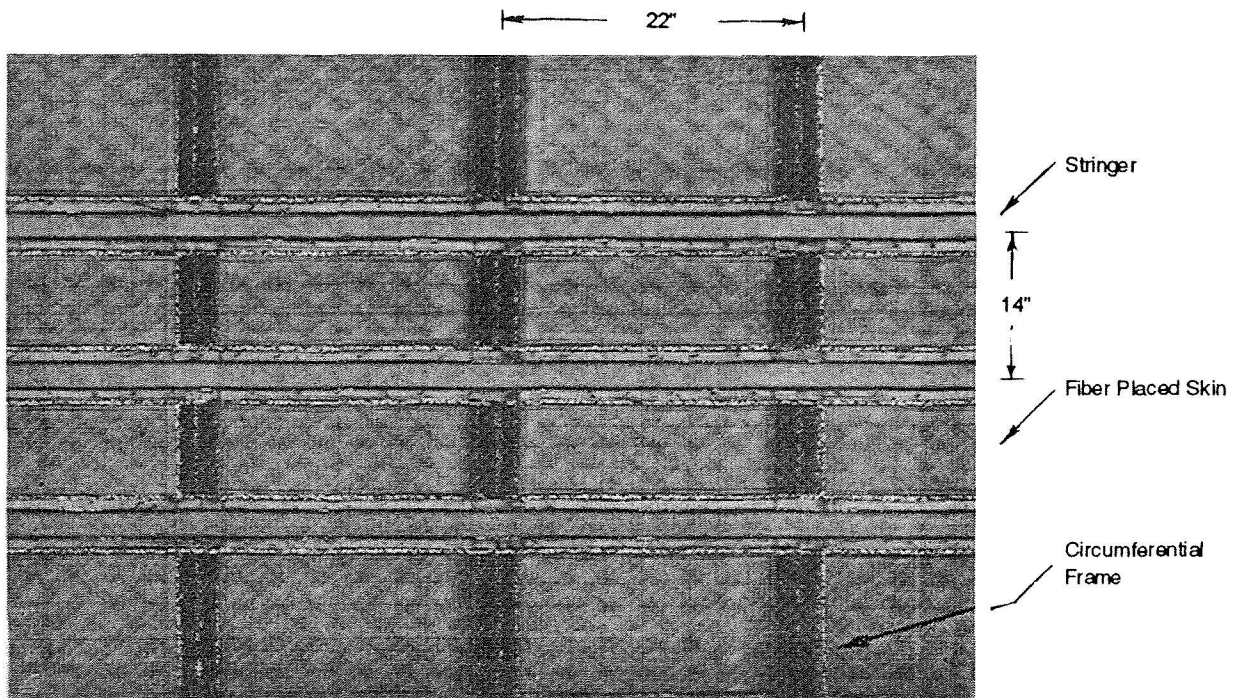
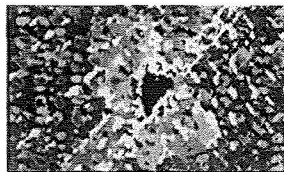
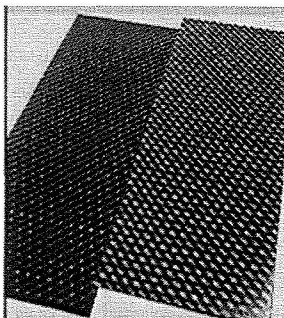

Figure 7-19: Inspection results for a crown subcomponent panel that used AFP to laminate the skin.



Tow-placed AS4/S2/938 intraply hybrid skins

Benefits

- Low-cost base materials
- Automated processes
- Complex part geometries
- Dimensionally stable
- Superior damage tolerance

Challenges

- Scaling laws
- Design criteria
- Adaptable tooling
- Factory repair
- Inspection procedures

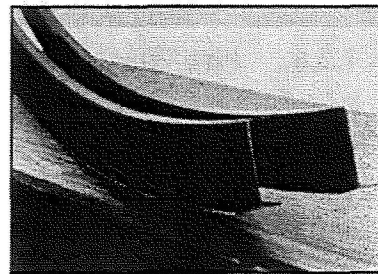

AS4/RSL 1895 triaxial braided frames

Figure 7-20: Advanced material forms pursued by ATCAS.

Fabrication of circumferential frames and full-depth sandwich close-outs using textile/RTM technology indicated process improvements are required to meet goals for tolerance-control. Tests of flat textile/RTM specimens also indicated the need for strict process control due to a strong dependence of structural properties on fiber architecture and fiber volume. References 8 and 11 provide additional details for these issues.

Traditional inspection methods (e.g., pulse-echo, TTU, X-ray) were used to characterize all configured panels that were fabricated in ATCAS. Difficulties were noted and development requirements were identified for applying these techniques to specific design details (e.g., frame/skin bondlines, hat-stringers). The ability of TTU techniques to identify delaminations in both sandwich facesheets was demonstrated, although their ability to detect facesheet porosity was not established. Structural analyses and tests were also conducted to evaluate the effects of defects on frame/skin bondline strength. This will be discussed further in Section 7.3.4.

7.2.5 Composite to Metal Interface

Fiberglass isolation was added to all designed aluminum-to-composite interfaces to avoid galvanic corrosion. For metallic parts, the increased stiffness and material/machining costs associated with titanium were contrasted with the isolation requirements for aluminum. In general, titanium was selected for fasteners and splice plates, while aluminum was chosen for external attachment brackets and most internal reinforcement fittings. Local loads induced by differing thermal expansion characteristics of such elements have generally not been considered in studies performed to date. A more systematic approach to facilitate the interface between composite skin panels and metal elements may be achieved through the use of fiberglass/epoxy fabric plies for entire IML and OML surfaces.

7.2.6 Fire Worthiness

Standard flammability and smoke release tests for fuselage interiors were conducted on materials being considered for fuselage skins and stiffening elements. The primary concern was whether the use of composites would result in a greater hazard to passengers and crew during aircraft evacuation in the case of a post-crash fuel-fed external fire. A summary of coupon tests performed on baseline ATCAS materials can be found in ref. 11. Future studies will need to address the behavior of configured structure in conditions of a post-crash fuel-fed external fire such that appropriate design requirements and objectives can be established.

7.3 Structures

This section summarizes major ATCAS achievements on structural issues. The focus will be on the design details considered baseline and/or scaled in manufacturing demonstrations for Phases A and B of the program. Technology for some advanced structural concepts pursued during the course of the program did not advance to a level of maturity that would allow them to be considered in major hardware. A more complete documentation of structural evaluations performed in Phases A and B of ATCAS can be found in ref. 6.

7.3.1 Internal Load Paths

Initial structural sizings were performed with internal load distributions based on a metallic fuselage design. During the last three years of ATCAS, a full-barrel FE model consisting of Phase A/B composite quadrant designs was developed to assess global fuselage response. This effort was performed under a complementary NASA contract with Boeing (Task 3 of NAS1-19349). Figure 7-21 shows a 1994 version of the model. Internal load distributions were generated using this model in conjunction with five critical external load cases, selected to represent the several hundred cases that define the full loads envelope.

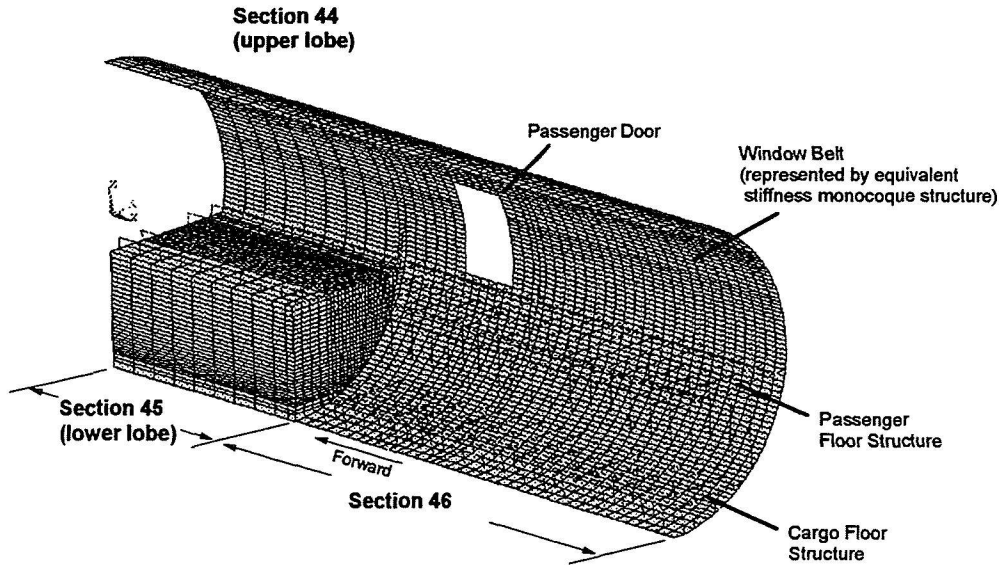

Figure 7-21: Finite element reference model used to determine internal loads within the study section (right half shown).

The model shown in Figure 7-21 underwent several refinements over time. These included (a) updates to quadrant panel stiffnesses, (b) revisions to passenger door cutout structure, (c) mesh refinements (keel tabout and discrete windows), and (d) additions of splice padups, intercostals and discrete frame shear attachments. As discussed in refs. 6 and 18, most of these refinements were found to improve the sharpness of internal load distributions.

Results generated from global models of the ATCAS quadrants supported design refinement of Phase A/B concepts. For example, internal load distributions were used in COSTADE analyses to perform sensitivity studies and update quadrant designs. Some of these studies resulted in significant changes in the stiffnesses of quadrant concepts, indicating a need to perform some iteration with the global internal loads model. An iteration performed with a relatively stiff crown design was found to result in some shift in the crown and keel loads distribution for the critical pitch-axis, body bending case (ref. 18). Software enhancements were developed towards the end of ATCAS, enabling the efficient transfer of element stiffnesses between global F.E. loads models and COSTADE. The benefits of this utility are discussed further in Section 7.5.3.

The results of global loads models were also used to prescribe boundary conditions for local FE analyses such as summarized in Section 7.3.2 and discussed in greater detail by refs. 6 and 18. This included efforts associated with the forward keel, passenger doors, and windowbelt. Correlation with structural tests helped to evaluate model accuracy in simulations of local design details (e.g., ply drops, cutouts, and bonded frame effectivity). Subsequent phases of the program will continue to enhance model accuracy in support of detailed strength prediction (i.e., stress concentrations, load redistribution, and failure criteria).

7.3.2 Detailed Strength & Stability Assessments

Complimentary stress analysis and allowables methods were pursued to 1) support the efficient design of structural configurations and 2) accurately predict the strength and failure mode of critical details. Several requirements were established in pursuit of such tools. First, predictive techniques must account for the curvature and highly-varying combined loads present in fuselage structure. Second, local load paths near areas of significant variation in structural detail must be developed from global loads model results. Third, methods for extending subscale test results to full-scale configured structure are required to ensure time- and cost-effective application of the technology. Finally, consideration of material forms, fiber architectures, layups, scale-induced attributes, and production processes during stiffness and strength characterization is critical.

Structural developments followed the ATCAS approach, including strong manufacturing integration, while considering other requirements described in the previous paragraph. In order to minimize the development costs, this approach used estimated allowables and closed-form analyses to quickly establish preliminary designs with representative details. These designs led to the fabrication of panels with sufficient size and enough detail to be meaningful for both manufacturing and structural evaluation.

In many cases, the hardware produced for the ATCAS program found multi-uses in structural evaluations. Large configured panels were often (1) instrumented, and tested to evaluate local load paths or stability, then (2) damaged and tested to failure to get large-flaw residual strength data, and then (3) remaining undamaged parts of the panel were machined into numerous elements and coupons (e.g., bonded frame pull-off, bolted joints, smaller-flaw residual strength, basic material allowables). Most tests with structural details were subjected to more rigorous analyses than used in preliminary design, including F.E. The combined detailed analysis and test results helped judge if some refinement in the design sizing and allowables approach was required to enhance predictive accuracy. In many cases some form of scaling was required.

Structural evaluations performed during the ATCAS program indicated the importance of manufacturing integration, while focusing coupon investigations on specific gages and layups of interest. Generally, only a small perturbation was needed to update structural details following initial tests. This iteration was used to convert the preliminary design to one that met all structural requirements. Any further material or structural allowables still deemed necessary after the first round of tests were generated for specific structural

details considered in refined designs. In addition to the inherent efficiency of such an approach, the importance of larger scales of evaluation became evident.

Important stiffness-related issues studied in ATCAS included (a) load distribution in the vicinity of splices and discontinuities, including cutouts, ply-drops and impact damage; (b) stability performance of sandwich structure in the presence of combined loading (compression/shear/pressure), disbanded and/or damaged facesheets, frame and/or intercostal details, and rapidly varying facesheet thicknesses, and (c) load redistribution in post-buckled stiffened-skin concepts. Strength issues included (a) combined loads effects, (b) bearing yielding, load redistribution, and failure in multi-fastener splices, (c) interactions with cutouts (windows, passenger doors, etc.), and (d) failure modes of medium- and heavy-gage sandwich structure, thick laminates, textile fiber architectures, and skin/frame bondlines.

Relevant analytical techniques and experimental databases have been developed. Boundary conditions from linear elastic FE loads models were applied to linear and nonlinear analyses of more detailed models to improve understanding of load distributions in the forward keel (e.g., see Figure 7-22) and side panels. Simplified methods for critical structural behaviors of each quadrant were developed and implemented into computer tools (e.g., spreadsheets, COSTADE), allowing more complete evaluation of alternative concepts during design development. Databases were also collected for a range of materials and forms, including AFP laminate and sandwich structure, as well as textile composites.

7.3.2.1 Crown Panel

Significant progress has been made in understanding critical failure modes for the crown, using combinations of analysis and test. Due to relatively simple load cases and lack of structural cutouts in the crown, the attention was directed to damage tolerance and bonded frame integrity. Soft-inclusion modeling of impacted stringer crippling tests was successfully accomplished. These results were incorporated in a nonlinear FE simulation of a multi-bay crown stability test panel that included impact damage to the skin and stringers, and a delaminated frame (see Section 7.3.3.2). Detailed FE analyses were used to develop test methods and interpret results for crown frame/skin bondline strength, including the mousehole area (see Section 7.3.4). Extensive modeling of crown tests supported development of the pressure-box test fixture. Correlations with several pressure-box tests were used to enhance modeling strategies required in extending results to fuselage configurations (see Section 7.3.3.1).

7.3.2.2 Keel Panel

Keel activities initially focused on the aft end of the fuselage section, characterized by relatively thin sandwich facesheets. Nonlinear FE techniques have successfully predicted unidirectional-compression sandwich stability tests. Generalized plane-strain models have been successfully applied to limited aft-keel frame pull-off and push-in tests, predicting failure modes and loads from simple coupon configurations (see Section 7.3.4).

Test and analysis of thicker mid-keel sandwich configurations were addressed in Phase B activities performed in 1994 and 1995. Other activities towards the end of Phase B addressed load redistribution and stability tests of forward keel configurations, and characterization of thick laminates representative of the forward keel splice region.

Detailed F.E. models, such as that shown in Figure 7-22, were used to analyze and design the forward keel to redistribute very large compression loads from the keel beam. Dark elements in the background of Figure 7-22 are the undeflected keel and lower side; the light elements indicate a non-linear deflection of this structure. Because there is so much interaction between the configured keel and lower side panels, it was necessary to include the lower side panel in this model. The running load introduced at the forward end is approximately 34 kips/inch. For the resulting stability analysis, uniform displacement was applied to the model over an approximated portion of the section 43 keel beam (which is bolted to the forward end of the section 46 keel panel with titanium splice plates). The aft end of this section was modeled to react the loads across its width, and the lower aft end is fixed in place.

The finite element model shown in Figure 7-22 used shell elements for the laminate facesheets, frames, and intercostals; solid elements for the core; and beam elements for the floor beams, roller trays, and stanchions. All structure simulated in the model was geometrically correct (no offsets, lumping, or smearing). The model encompassed 13,980 nodes and 13950 elements, which led to approximately 60000 degrees of freedom. Sandwich facesheets have a "ply-by-ply" representation in the model, allowing a detailed view of the strain patterns.

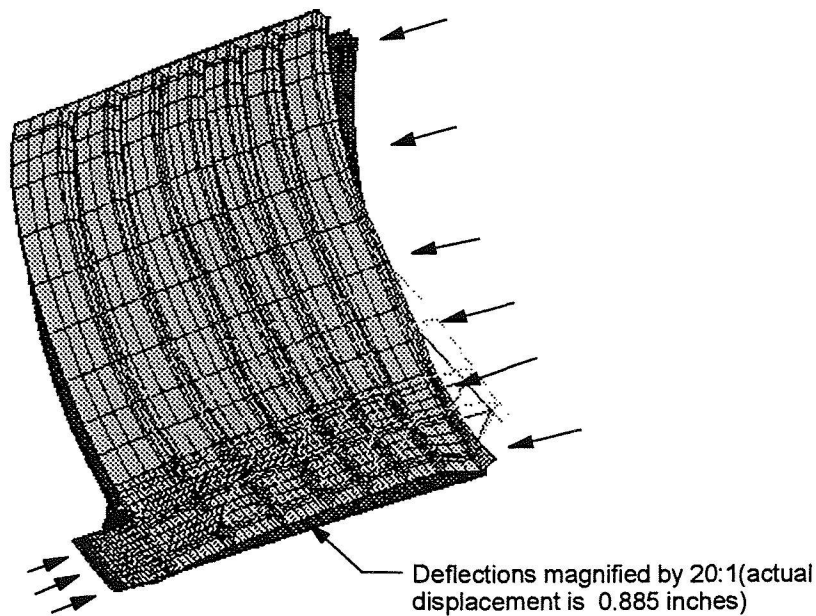

Figure 7-22: *Detailed finite element analysis of keel to side compression load redistribution and stability.*

Several linear finite element runs (of several different designs) were also performed using the model shown in Figure 7-22 to understand the nature of peak panel strains. Ply drop schemes that maintained additional $\pm 45^\circ$ plies along the edge of the keel panel were found to be more effective at redistributing the concentrated tab loads into the lower side panels. The keel panel was predicted to fail at approximately 138% of design ultimate load, leading to the deflected shape shown. The failure is specifically predicted to occur in bearing/bypass of the loads entering the tab at the forward bolted joint, and further modeling work and bolt data for thick laminates are needed to arrive at a better understanding of the failure. Additional detailed results from this model are covered in ref. 18.

A large panel with ply build-ups, core insert details, and an inplane tab characteristic of the forward keel was designed for manufacturing demonstration and compression load redistribution tests at NASA Langley. This panel was successfully fabricated in 1995. Goals of the subsequent compression tests at NASA include an assessment of overall load paths, stress concentrations, and stability. Analysis performed to date using an F.E. model with similar resolution to that shown in Figure 7-22 helped define recommended load and boundary conditions.

7.3.2.3 Side Panel

Much of the side quadrant has structure similar to that found in the aft keel. Most Phase A/B activities to characterize the strength and stability of sandwich details unique to the side quadrant were limited to window-belt panels and passenger door cutout reinforcement structure. Two window-belt subcomponent panels were scheduled for test at NASA Langley, starting in 1995. Most of the detailed analysis performed for the passenger door was done under subcontract with Northrop/Grumman. The only hardware designed and built for this effort was the door edge frame members discussed in Section 7.1.1.3 (see Figure 7-9).

The first window-belt panel was fabricated for pressure-box tests at NASA Langley. Figure 7-23 shows this pressure-box test panel which was machined from the manufacturing demonstration panel shown in Figure 7-8. The basic panel design for this subcomponent was based on side global evaluation results with the cutout doubler detail defined using the RARICOM Raleigh-Ritz-based cutout analysis method (refs. 27 and 43). A detailed F.E. model was subsequently used to generate strain and deflection predictions under the proposed test scenarios and analyze the effects of the pressure-box test fixture. A number of different loading sequences for this two-window test panel were analyzed and tested (ref. 27). Goals of these pressure-box studies were to evaluate:

- (a) strain distributions near skin doublers and window cutouts,
- (b) the effectivity of bonded circumferential braided/RTM frames,
- (c) the effectivity of bolted braided/RTM window ring frames and full-depth closeouts,
- (d) removal of the center body frame to evaluate effects of increased frame spacing, and
- (e) damage accumulation from a flaw introduced near the window cutout.

The sandwich windowbelt panel shown in Figure 7-23 successfully completed all test sequences near the end of Phase B. A comparison of analysis and test results for this panel is planned in Phase C to achieve all goals listed above.

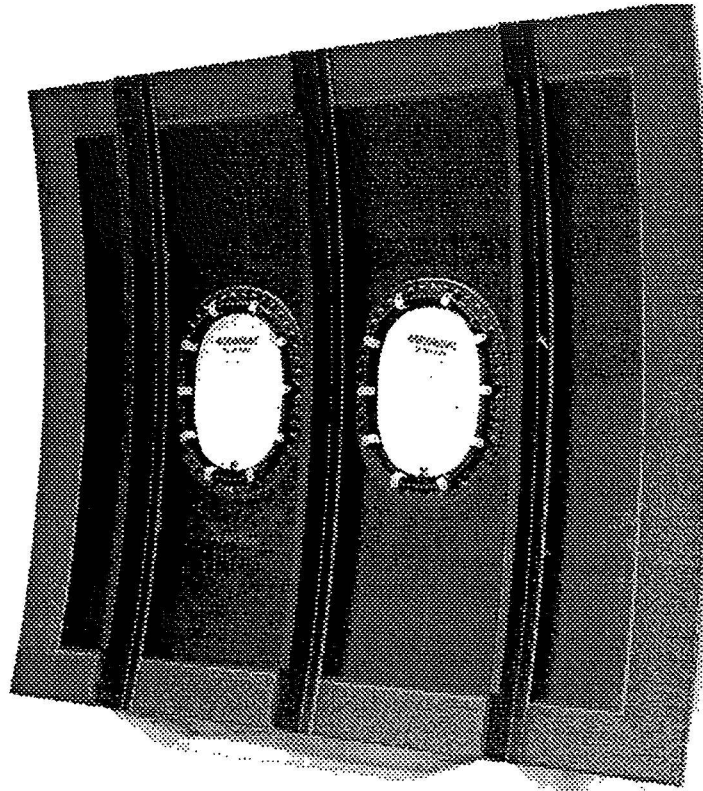

Figure 7-23: Window belt pressure box test panel.

An analytical study was undertaken to further optimize the windowbelt design, particularly in regards to the effects of shear loading, which is a dominant design driver for the window belt. Detailed finite element analyses were performed for a side panel windowbelt segment consisting of three frames, three full-depth core close-outs, and three windows. These analyses led to significant design refinements. First, the doubler thickness was reduced but its width was increased. In addition, these analyses indicated that a simpler, lower-cost, window frame was acceptable (see Figure 5-10). Finite element results for the original design (as represented by the test panel in Figure 7-23) and the reconfigured design are shown in Figure 7-24 for shear loading combined with internal pressure. Additional details of the analysis are documented in refs. 18 and 27.

Another design option considered for the side quadrant was a concept with increased frame-spacing (from 21 inches to 42 inches). Local finite element results for such a configuration, using loads from the forward end of Section 46, indicated some minor shifts in peak windowbelt strains (ref. 18). When the frame spacing is increased to 42 inches, the strains increase by approximately 4% compared to a 21 inch frame spacing, when subjected to the maximum shear loading combined with internal pressure. Although increased frame spacing may present problems in other areas (e.g., floor structure interface), this result and the high potential for cost savings justify future evaluations.

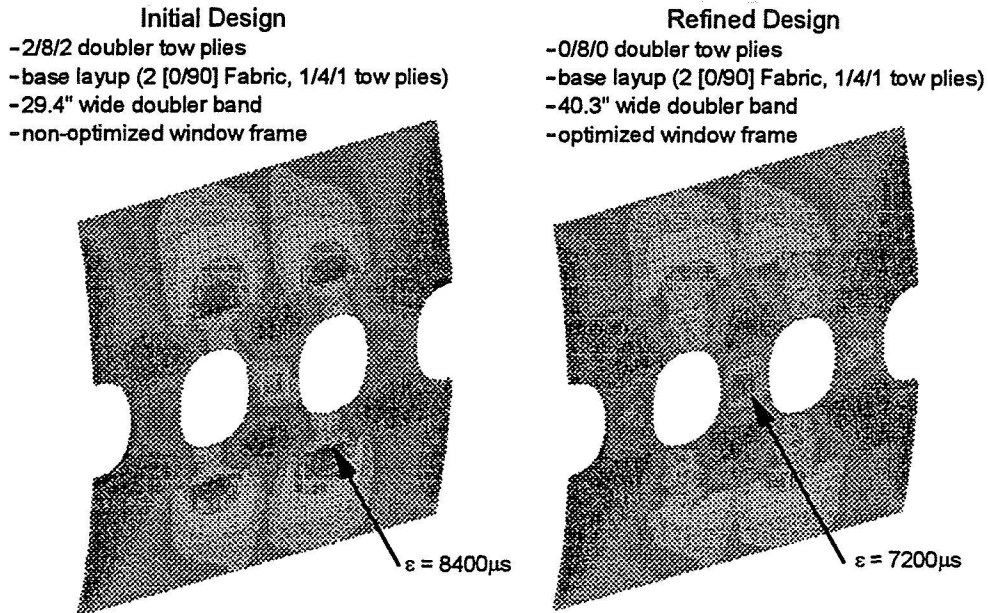

Figure 7-24: Comparison of peak strains for original and optimized windowbelt designs.

The optimized design, whose analysis results are shown in Figure 7-24, was used as a basis for design of the second windowbelt sandwich panel (see Figure 7-25). This 7 ft. by 10 ft panel was successfully fabricated at the end of Phase B. It will be used for manufacturing and structural assessments.

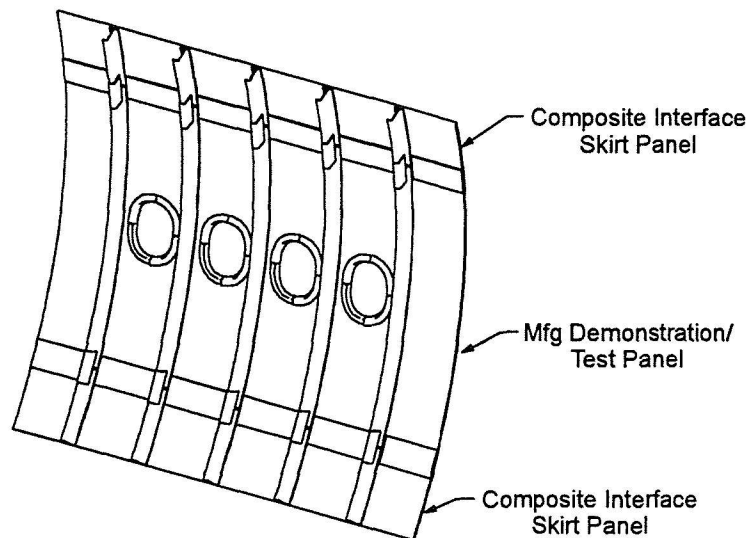

Figure 7-25: Second manufacturing demonstration panel configured for testing in the D-Box facility.

Following manufacturing tolerance evaluations and test preparation, the panel shown in Figure 7-25 will be delivered to NASA Langley in the first quarter 1996 for testing in the D-box test facility. As indicated in the figure, composite skirt panels will be fabricated and mechanically fastened to the window-belt panel to meet the D-box's 120-inch by 120-inch aperture. Preliminary test plans build on results obtained from pressure box testing, with the important addition of shear loading. Both undamaged strain surveys and damage tolerance evaluations are planned. Maximum design loads for the panel are 2500 lb/in axial, 18.2 psi internal pressure, and 1350 lb/in shear.

Collaborative efforts between Boeing and Northrop/Grumman led to passenger door design refinements. The latter has been involved in structural analysis of door details using optimization capabilities of the ASTROS (Automated Structural Optimization System, ref. 44) finite element code. This analysis has used boundary conditions from Boeing's global internal loads model (ref. 18). An ASTROS local model of the passenger door structure as shown in Figure 7-26. A total of forty-four design variables were defined within the ASTROS model, controlling features such as skin thickness and layup, and sill, edge and auxiliary frame flange, cap and web thicknesses. Results of this model are discussed in refs. 27 and 43.

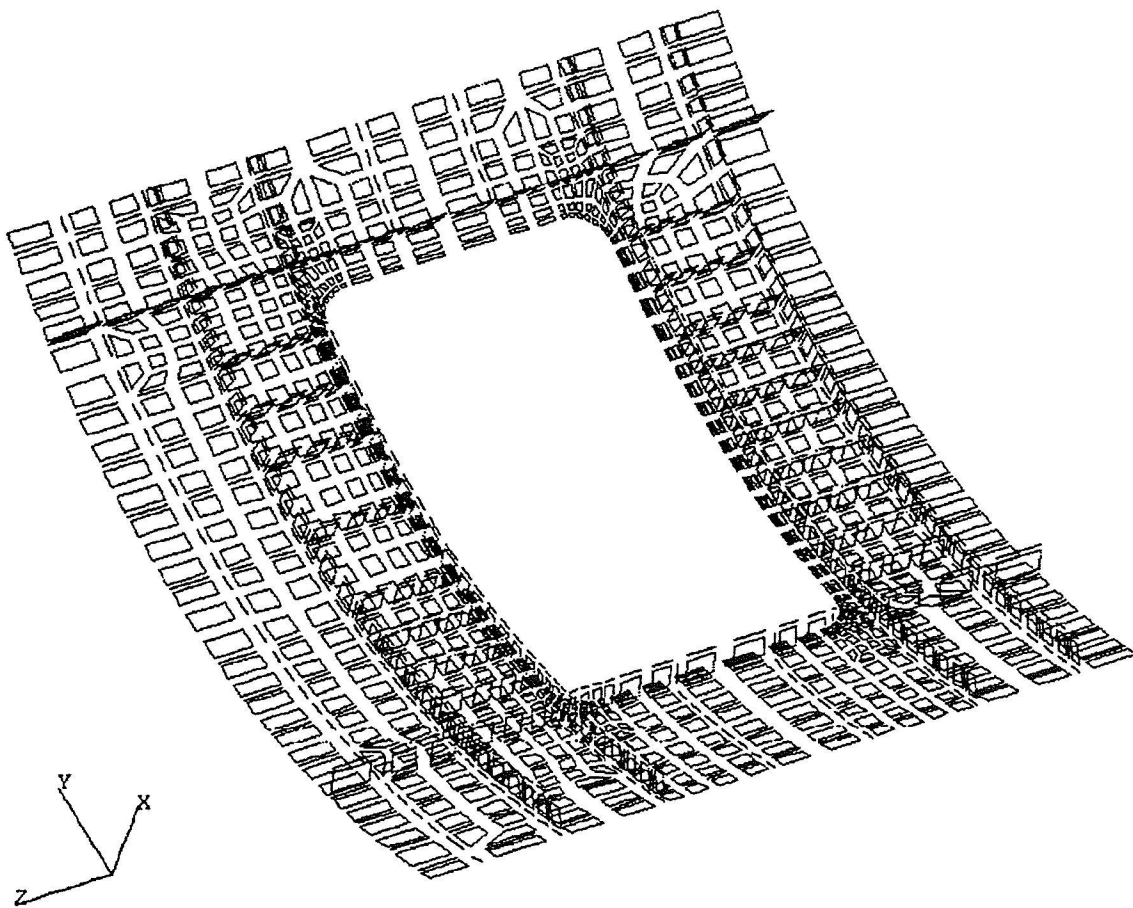

Figure 7-26: ASTROS passenger door cutout finite element model.

7.3.2.4 Circumferential and Longitudinal Panel Splices

Characterization of splice behavior for both skin/stringer and sandwich panel configurations has been limited. Basic bolted joint characterization tests have been conducted on AFP carbon/epoxy and hybrid carbon/glass/epoxy laminate coupons (ref. 11). Some experimental and nonlinear FE studies of bolted joints for a forward keel splice have been performed (refs. 11 and 45).

Sandwich panel splice concepts that have been investigated during Phase A/B of ATCAS are shown in Figure 7-27. Prior to the fabrication of a splice test panel, splice details such as the full-depth longitudinal splice shown on the bottom left of this figure were fabricated as part of large manufacturing demonstration panels. The web of the close-out was only 0.04 inches thick, which was not thick enough to handle fastener clamp-up loads. Subsequent close-out designs modified this detail by using solid laminate sections for fastener support. The "matched-ramp" longitudinal splices, shown on the right of Figure 7-27, and the symmetrically tapering circumferential splice were also fabricated to get test coupons. Static and fatigue tests have been performed with elements representing all three of the splice sections shown in Figure 7-27 (ref. 11).

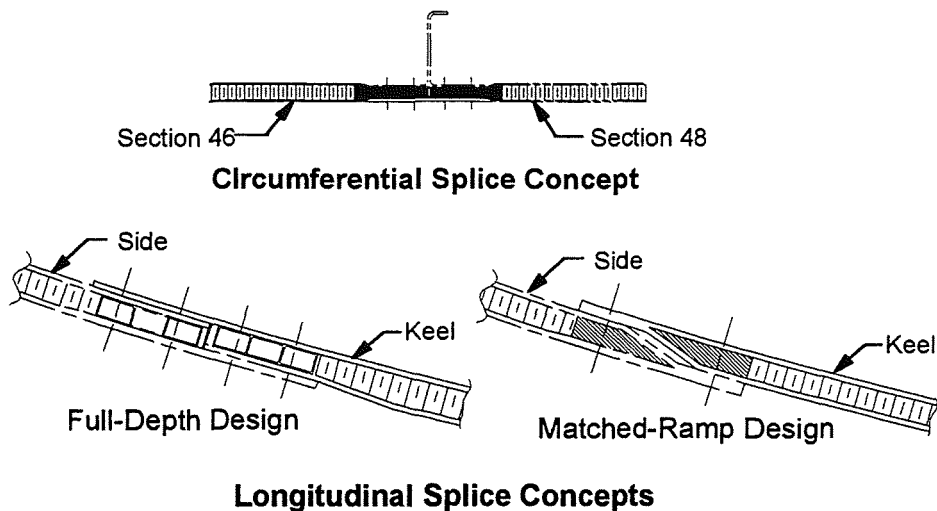

Figure 7-27: Development of sandwich panel close-outs.

7.3.3 Damage Tolerance

As discussed in Sections 7.2.1 and 7.2.2, a significant database has been collected in ATCAS on composite notch sensitivity (tension and compression). Several structural evaluations, involving analyses and tests, have also been performed. The combined database and supporting analyses have led to some understanding of material, laminate, structural, and manufacturing variables crucial to composite fuselage. This subsection gives a brief synopsis of the ATCAS structural damage tolerance work performed to date. References 6, 7, 17, 38, 39, 40, and 46 provide a more thorough description. Subsequent studies are required to quantify the effects of combined loads (including compression, shear, and pressure), dynamic pressure containment, fatigue, and other damage scenarios.

Structural tests and analyses have evaluated the ability of selected ATCAS skin/stringer and sandwich configurations to meet fuselage damage tolerance requirements and design goals. Key factors affecting damage tolerance performance include notched strength properties for laminated skins, structural configurations, and load transfer from damaged skin to bonded elements (frames or stiffeners). Notched strength properties have proven to be one of the most dominating factors for ATCAS designs. For example, the advantages of intraply hybridization to large-notch, tension fracture strength have been found to translate to structural configurations in Phase A/B (see Figure 7-28). Structural test results have also confirmed the need to consider inelastic responses in residual strength predictions, including the damage growth and resulting load redistribution. Application of the strain-softening approach to predict damage growth in structural configurations has been successful, but simulations of reduced load transfer to discrete bonded elements had not been completed by the end of Phase B.

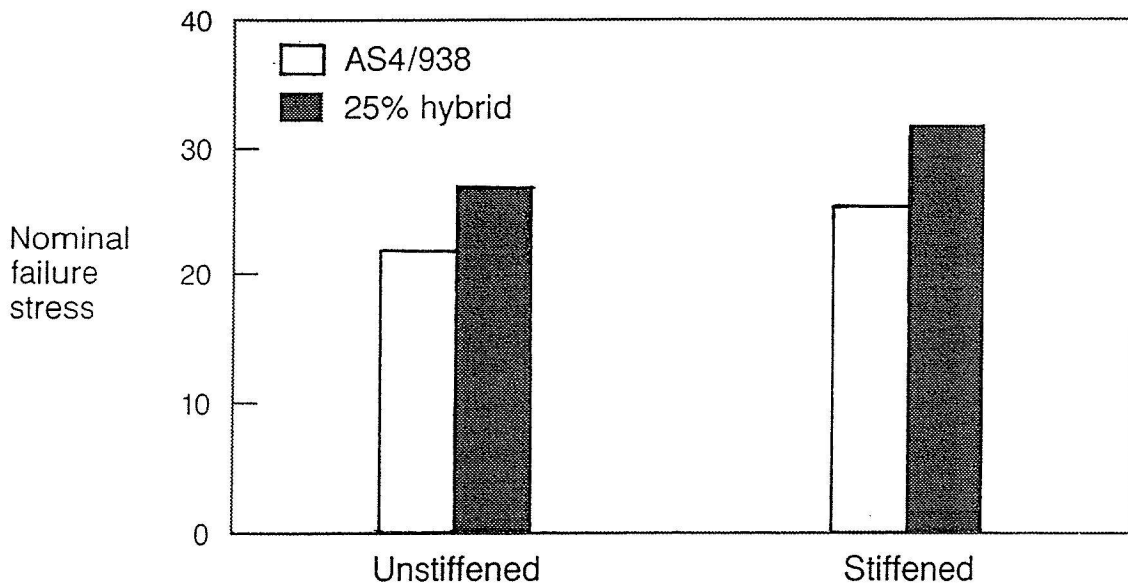

Figure 7-28: Residual strengths of unstiffened and stiffened fracture panels tested for crown designs.

7.3.3.1 Tension Performance

Both axial and hoop damage tolerance were evaluated for crown structure. The former considered high axial loads for critical pitch-axis, body-bending, maneuvers with penetrating damage that severed skin and hat stringers. Hoop damage tolerance included pressure load cases (with and without body-bending) and penetrating damage that severed the skin and circumferential frames.

Discussions of axial damage tolerance tests performed for ATCAS crown panels can be found in references 6, 9, 17, 38, 39, and 46. Figure 7-28 shows nominal failure stresses for two flat, 5-stringer, crown panels that represented the largest scale tested for axial loads in Phases A/B. Similar failure modes and nonlinear, inelastic load transfer was

observed as damage growth in each panel approached the arresting stringer. However, as discussed in reference 9, a relatively simple residual strength analysis was found to accurately predict the failure of these two panels. This analysis was based on skin large-notch fracture properties, skin stiffness, stringer spacing, and stiffening ratio.

Benchmark pressure-box tests for configured crown panels have been ongoing since 1992. These tests were defined to study hoop damage tolerance, ultimate strength, and bonded frame integrity for curved, configured panels. A total of nine panels will be tested to evaluate several variations in crown design detail (e.g., bonded vs. bolted frames). Figure 7-29 shows one of the five crown panel tests performed in the pressure-box fixture to date. The test fixture was built and the first two tests were performed at Boeing (ref. 47). In 1993, the Boeing-built fixture was transported to NASA Langley and reassembled for subsequent tests. Note that the sandwich window-belt panel described in Section 7.3.2.3 was also tested in the pressure-box shown in Figure 7-29.

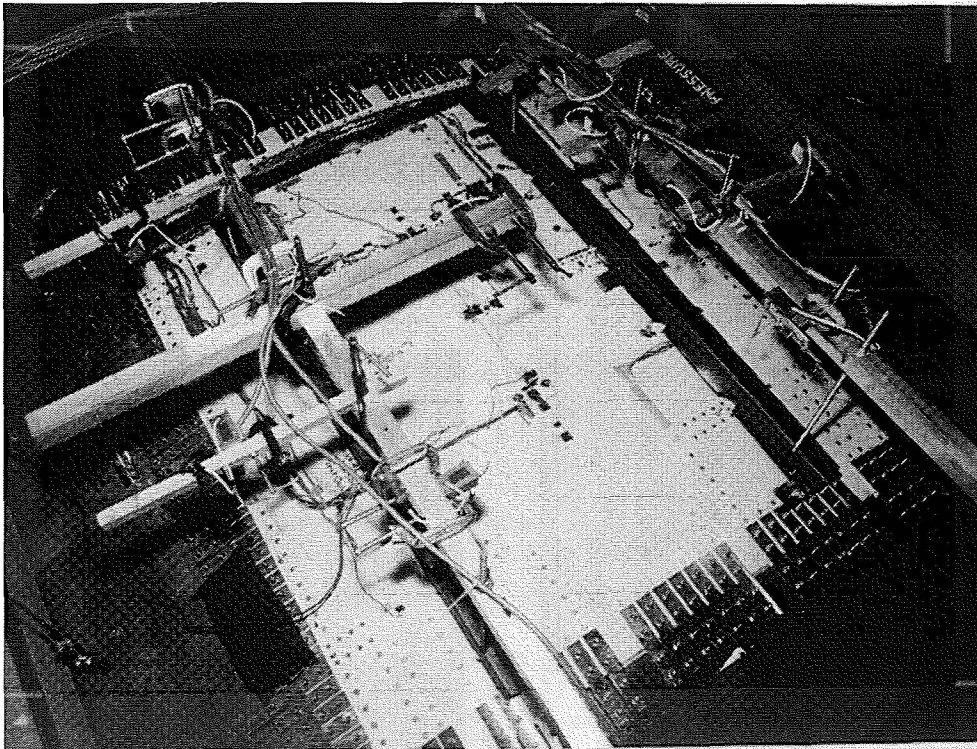

Figure 7-29: Pressure-box structural test set-up.

Bolted frame crown designs tested in the pressure box have been found to have adequate pressure capability and damage tolerance. Intraply hybrid skins were found to have superior damage tolerance, sustaining 15 psi internal pressure with large discrete source damage. Graphite/epoxy panel designs, having close to the same areal density, failed similar tests at approximately two-thirds of this pressure level. Additional discussion on hoop damage tolerance tests performed using the pressure box and supporting analyses can be found in references 6, 7, 39, 47, 48, and 49.

Another focus of pressure-box testing has been on bonded frame design details. Early failure occurred to one pressure-loaded panel subjected to high axial loads. Fracture of this panel appears related to biaxial load introduction and the associated higher stresses at the test panel edges near axial fixture attachments (ref. 48). Analyses indicate that metal doublers that were bonded to outside skin bays increased stresses near outer frames in this test panel. Bonded metal doublers were used for high axial load introduction rather than bolted attachments because the test panel had relatively soft axial stiffness and was believed to have insufficient bearing/bypass capability. During the course of panel failure analysis, high axial tension loads were also found to aggravate the pressure pillowing load and moment distribution for bonded frame pull-off. Additional analysis showed that a relatively stiff panel design identified at the end of crown studies (see discussion in Section 5.1) would lower the effects of high axial loads on pressure pillowing moments and eliminate the need for bonded metal doublers in pressure-box testing. This improved skin design also needs to be checked for damage tolerance as related to the mousehole detail.

7.3.3.2 Compression Performance

Work in compression damage tolerance was performed for the forward crown and aft keel. Figure 7-30 shows two major compression tests that were performed at NASA Langley in support of designs in these areas. Note that the maximum compression loads for the forward crown (skin/stringer design) and aft keel (sandwich design) were similar. Special test fixturing (panel edge and frame attachments) was designed to simulate fuselage loading. Before evaluating a range of damage scenarios, each test also accessed panel stability.

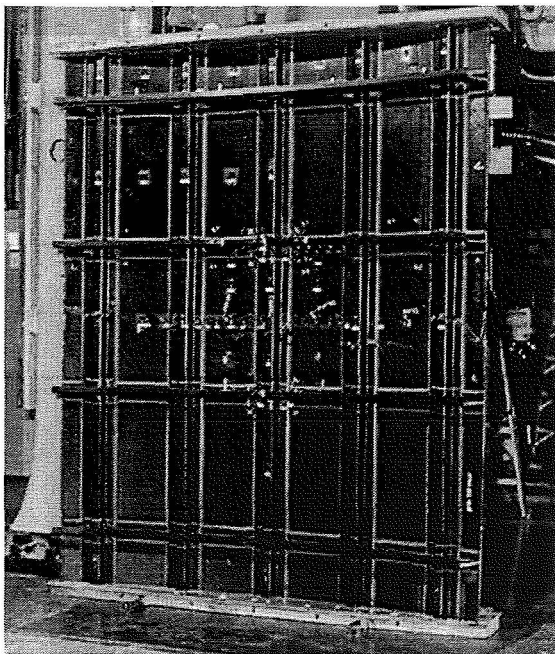

Forward crown

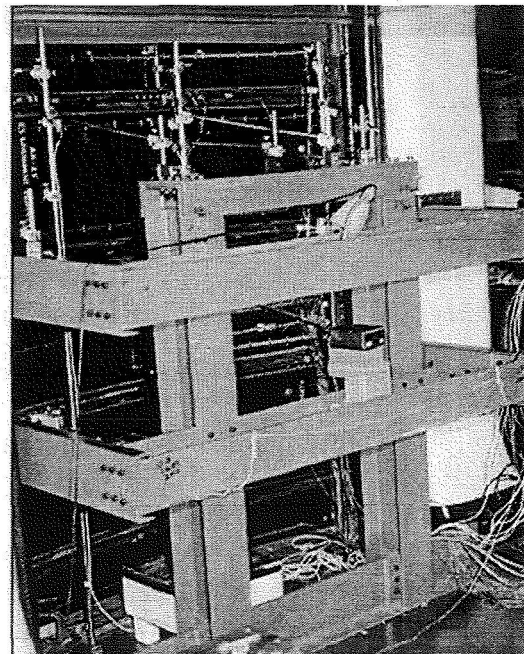

Aft keel

Figure 7-30: Major axial compression tests and analysis.

Analysis and test results for the forward crown panel shown in Figure 7-30 have been documented (ref. 50). Damage scenarios included barely visible impact in critical locations and a portion of a frame removed to simulate debonding. The latter was repaired before testing the panel to failure. Results from this forward crown test indicated that the hat-stiffened panel with bonded, mouseholed frame had more than sufficient capability for crown compression stability and damage tolerance requirements.

Analysis and test results for the aft keel panel shown in Figure 7-30 have been documented (refs. 38 and 39). A range of damage scenarios and load cases were analyzed for this test panel in order to obtain the maximum amount of experimental data. Damage scenarios that increased in severity were added to the panel and failure predictions were used to define peak loads such that the panel did not fail until the final loading sequence. Damage included barely visible impact on the OML, a 4 in. penetration in the OML facesheet, and an 8 in. penetration through both facesheets. The interactions between local softening, stability and damage growth were well predicted for all cases. The complete series of tests successfully demonstrated each associated design goal and the panel failed in the last loading sequence at seven percent above the predicted load.

As discussed in previous sections, a number of major keel and side test panels were fabricated near the end of Phase B. A "forward keel" test panel was designed and fabricated to evaluate the redistribution of high compression loads near significant skin ply drops and a tabout simulating the wheel well cutout. Window-belt panels for both the Boeing and Lockheed sandwich designs were also fabricated and prepared for combined load testing at NASA Langley (ref. 51). Structural tests for these panels are planned in 1996 and 1997. Some damage scenarios will be considered for both forward keel compression load redistribution and window-belt combined load tests. Subcomponent tests and analyses for combined load conditions, including compression, shear, and pressure, are crucial to continued advancements in composite fuselage technology. A complete evaluation of the effects of large cutouts (e.g., doors), major splices, and explosive decompression will ultimately require structural tests with a configured fuselage section.

7.3.4 Bonded Frame Integrity

The baseline design concept in each quadrant includes bonded frames. As discussed in previous sections, the crown has a skin/stiffened design, while the keel and sides use sandwich. Figure 7-31 shows that sandwich construction has much greater resistance to bonded frame pull-off failures, such as those occurring due to cabin pressure loads. This directly relates to the increased bending stiffness of sandwich skin panels. Note that pull-off loads for both skin-stringer and sandwich designs increase with skin and facesheet thickness, respectively. Only small improvements in pull-off strength have been noted when increasing sandwich panel facesheet thickness from 10 to 30 plies. Note that core debond failure was observed only in sandwich tests with thin facesheets.

The pull-off strengths shown in Figure 7-31 are indicative of test results obtained for shear-dominated loading. This is the critical load condition for sandwich designs which

fail due to peak stresses below the frame web. In the case of the skin/stringer design, lower pull-off forces than those shown in Figure 7-31 were noted when using longer loading spans due to an increased peeling moment at the edge of the frame. For moment-dominated cases, pull-off force is not a good measure of bonded element strength.

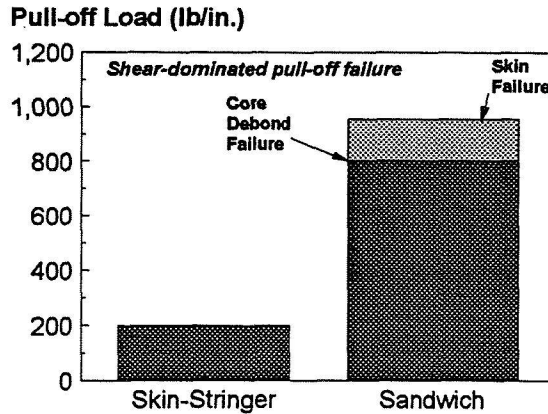

Figure 7-31: Bonded frame pull-off strengths for crown and keel design concepts (see test specimen & fixture in Fig. 7-34).

Pressure pillowing analysis performed to support building block tests and fuselage design helped establish procedures for scaling element pull-off test results to the configured crown structure (refs. 6, 7, 52 and 53). This analysis revealed that peak peeling stresses occur for the crown skin/stringer design at the edge of the frame flange. Figure 7-32 shows a micrograph cross-section of this area at the start of failure. Cracking in a resin rich ridge, followed by matrix crack growth to three plies deep in the skin, occurs prior to delamination growth. Preferred growth in the skin relates to the lower toughness of AS4/938 material. Numerous tests supporting this effort, including an evaluation of variations in design and manufacturing details, were also performed as part of a subcontract with Drexel University (ref. 54).



Figure 7-32: Frame pull-off failure in skin-stiffened crown design.

The mouseholed structural detail found in the baseline crown design (see the test specimen in Figure 7-33) aggravates local frame bondline peeling and skin tensile stresses for cabin pressure and high axial load cases (refs. 53 and 55). As discussed in Section 7.1.1.1, this area also complicates panel fabrication issues. Ongoing pressure-box testing at NASA Langley is currently assessing whether the bonded mousehole region of the crown design has sufficient structural integrity. In late 1995, a pressure-box test was performed to evaluate the effect of two ultimate pressure load cases on bonded mousehole strength. The bonded frame crown design was found to meet these requirements, while sustaining minimal matrix damage and delamination in a resin rich zone located at the frame flange edge within the mousehole (ref. 6). The combined case of high axial loads and pressure still requires attention in future pressure-box tests.

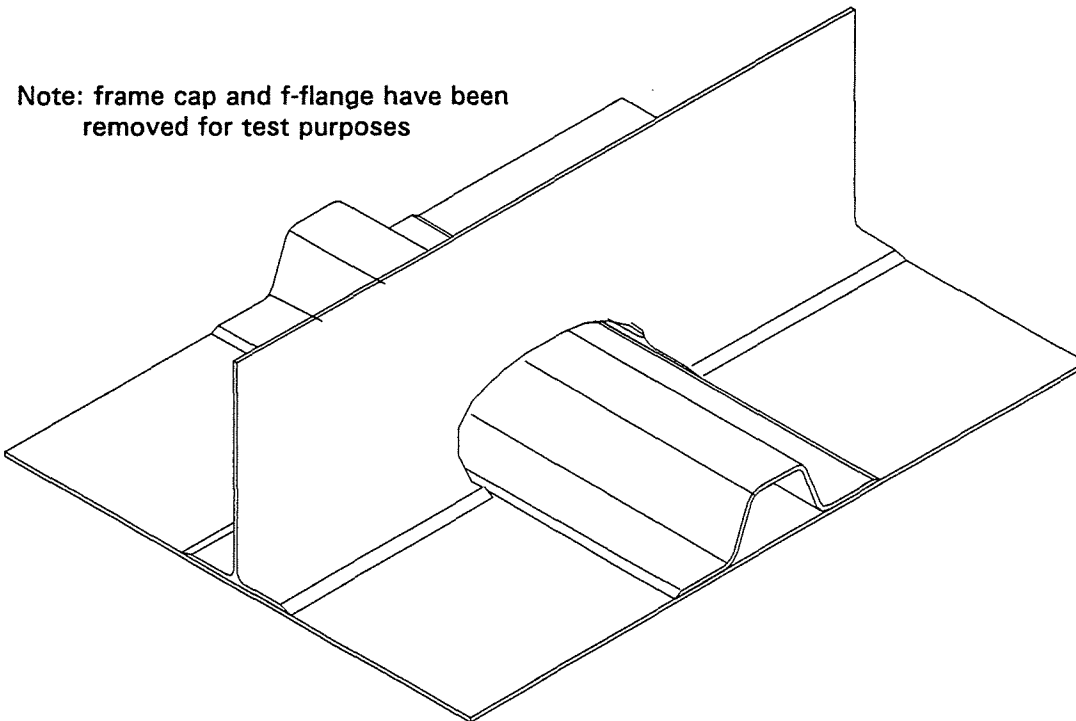

Figure 7-33: Test specimen to evaluate mousehole crown design detail at the intersection of bonded frames and hat-stiffeners.

Demonstration of the durability of composite structures is also essential to obtaining airline acceptance of composite fuselage design concepts. The durability of sandwich structures and bonded attachments are of particular concern. Materials and design details resistant to fatigue damage or defect growth under fatigue loads are also desirable. Accurate models for predicting fatigue damage formation and growth, and growth of manufacturing defects are needed to establish appropriate inspection intervals. Fatigue tests of crown and keel configurations were conducted to assess frame/skin bondline response, both with and without defects (e.g., Figure 7-34). These tests suggested that each configuration had some sensitivity to fatigue, but at loads that were well above ultimate requirements. The crown mouseholed design detail requires more work to ensure structural durability for at least 20 years of service typical for commercial aircraft.

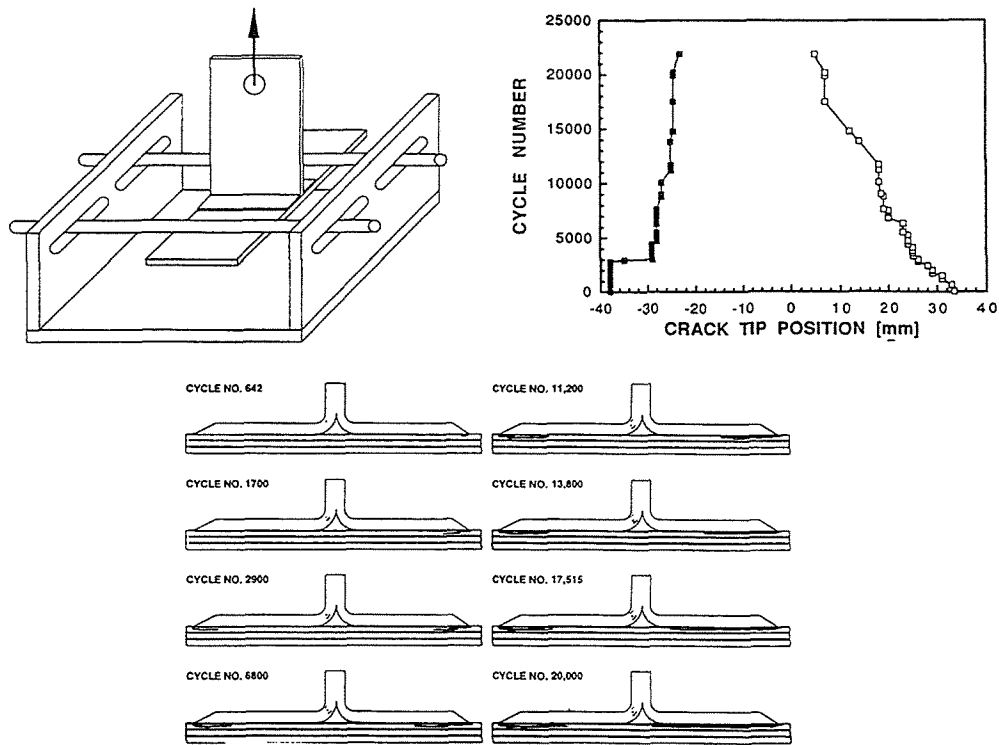

Figure 7-34: Fatigue crack extension for a bonded crown frame element subjected to extreme pull-off loads.

7.4 Maintenance

This section summarizes major ATCAS achievements on maintenance-related issues. Affordable maintenance technology is crucial to airline acceptance of composites in transport aircraft structures. This was pointed out early in the ACT program by the steering committee which recommended more efforts are needed to address the "ilities", including inspectability, repairability, reliability, durability, and, in general, maintainability. Figure 7-35 shows the maintenance development guidelines which were adopted per this recommendation during Phase B of the ATCAS composite fuselage program. A more complete documentation of structural durability and maintenance-related evaluations performed in Phases A and B of ATCAS can be found in references 11 and 56, respectively. Additional details are also presented in references 38, and 57 - 59.

A cornerstone of the ATCAS maintenance development philosophy shown in Figure 7-35 is damage tolerance. Tension and compression notch sensitivity curves discussed in Sections 7.2.1 and 7.2.2 can help supplement the structural residual strength database needed to assess the allowable damage limits (ADL) and critical damage thresholds (CDT) defined in Figure 7-35. The ADL allows quick determination of the need for repair during scheduled inspection. The CDT should be sufficient to allow safe aircraft operation between inspection intervals. Knowledge of the residual strength curve, structural load

paths, and inspection capabilities should allow determination of both ADL and CDT as a function of location for the entire structure.

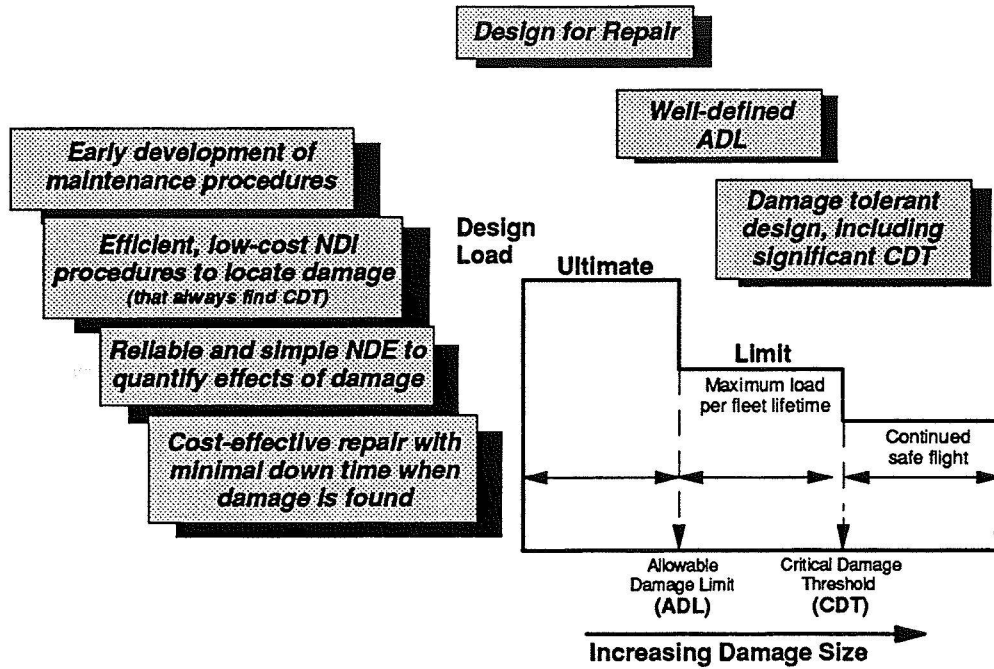

Figure 7-35: Rules for maintainable composite structure.

Inspection and repair applicable to a service environment must also be considered during design selection. Subsequent design concept developments should include parallel efforts to establish maintenance procedures in each of these areas. Composite repair processes, inspection methods, and any required investment in equipment should be affordable to airlines. Nondestructive inspection (NDI) and evaluation (NDE) procedures used during scheduled maintenance will need to be practical for damage location and quantitative disposition, respectively. Ultrasonic NDE methods should only be used to assess the effects of damage found by more easily performed NDI procedures (e.g., visual).

7.4.1 Inspect and Quantify Effects of Damage

Common damage threats for composite structure include (1) impacts caused by accidental vehicle collision or foreign objects (e.g., runway debris, hail, tool drop), (2) overheated surfaces, (3) lightning strike, (4) erosion, or (5) other environmental effects (e.g., UV exposure, moisture uptake, or thermal cycles) which can also degrade existing damage (ref. 60). There is often little or no detailed information on the event that caused the damage found in service (e.g., impactor geometry, energy levels, time since occurrence). As a result, studies involving standard impacts have limited direct benefits to maintenance. Procedures are needed to quantify the extent of damage and its effect on residual strength. These procedures will also help simplify the required repair (e.g., number of plies and scarf area for bonded repairs).

Preliminary impact studies have been performed for structural design details in all ATCAS quadrants (refs. 11, 19, 22, and 57). As related to maintenance, the main purpose of these studies was to (1) understand critical damage characteristics (i.e., those which are least visible, while having the strongest effect on residual strength) and (2) develop suitable NDI and NDE procedures.

The most complete impact study was a designed experiment performed for stiffened structure with skin gages typical of the ATCAS baseline crown design (ref. 57). This study evaluated the effects of a wide range of impact threats on resulting damage to differing material and structural configurations. Important intrinsic (material, laminate, and structural) and extrinsic (impact scenarios, impactor characteristics, and environment) variables affecting characteristic damage states were identified, and NDE methods capable of assessing the size and stiffness of damaged regions were demonstrated. Different impact locations on the structure (e.g., stiffener flange, skin midbay) were also evaluated. Dynamic finite element analyses, such as those illustrated in Figure 7-36, were used to help simulate an interaction between specific combinations of intrinsic variables and impact events. Other studies performed in ATCAS used structural analyses and tests to evaluate the effects of impact damage on laminate strength and stability, stringer crippling, skin/stringer panel stability, sandwich panel strength and stability, and frame/skin bondline strength (refs. 6, 11, 19, 38, 40, 50, 53, and 63).

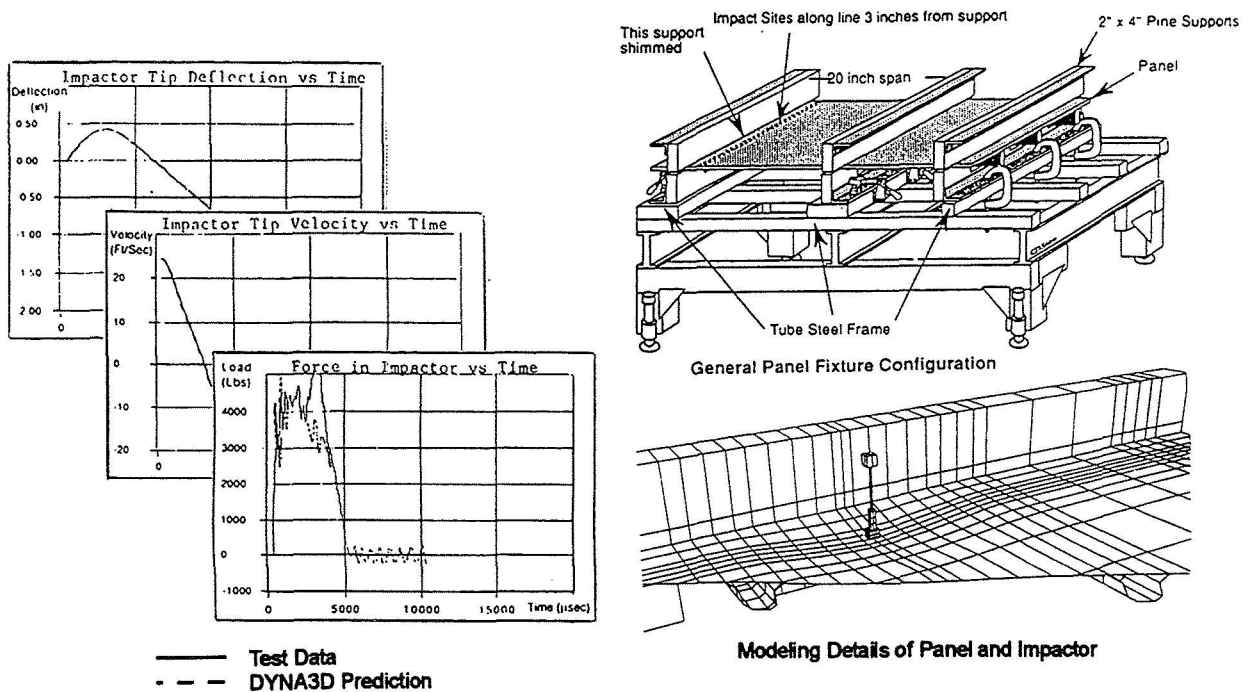
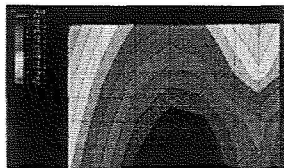

Figure 7-36. Results from finite element simulation of three-stringer composite panel impact tests correlate well with experimental measurements.

Results from the impact designed experiment (Ref. 57) and thermal distortion analyses (Ref. 38) both indicated that the use of a detailed visual inspection to detect potential composite damage may be suitable for NDI but it appears limited as applied to NDE. The left side of Figure 7-37 shows how "back-side" damage to a laminated composite structure can affect local distortion on the front surface of a panel (ref. 38). Efficient techniques for performing a detailed visual inspection over large structural surface areas exist (refs. 61 and 62); however, the total inspection costs (including the equipment acquisition costs) for such procedures must be acceptable to airlines.

The right side of Figure 7-37 shows an NDE method pursued in ATCAS for quantifying the effects of impact damage. This method, which was referred to as an "automated coin tap" by airlines participating in an ATCAS DBT, appears to have promise as a reliable procedure for use in-service. Good correlation has been found between the reduced local stiffness experimentally measured by Lamb wave dispersion and out-of-plane mechanical loading devices (ref. 57). Other methods evaluated in these experiments had little or no correlation with the mechanical load measurements.

Efficient methods to find damage
(analytical simulations of local distortion)



Undeformed surface contour

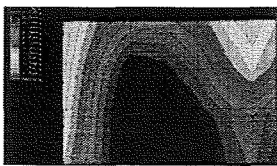

Deformed surface contour

Reliable methods to quantify damage
(Lamb wave dispersion developments)

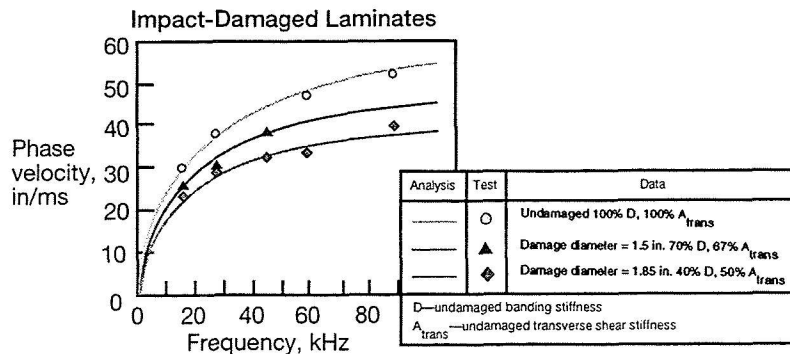
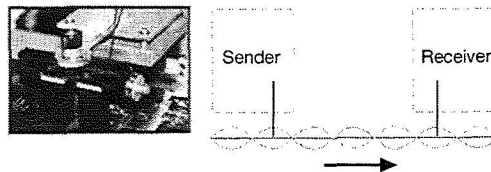

Figure 7-37: Support for procedures to locate and characterize damage.

7.4.2 Sandwich Water Ingression

The ATCAS selection of sandwich design concepts for side and keel quadrants has brought out concerns for durability issues related to water ingression. Studies performed at Boeing (ref. 11) and the University of Iowa (ref. 64) attempted to isolate water and moisture transport mechanisms in sandwich structure. Studies at Boeing focussed on (i) core permeability, (ii) core and facesheet integrity (resistance to matrix cracking under static and fatigue loads), and (iii) ground/air/ground cycles for sandwich panels with

portions of the core exposed to moisture. The University of Iowa had a subcontract to study moisture vapor and liquid water transport mechanisms between cells exposed to high humidity environments and those isolated by distance. The experimental apparatus designed for these tests embedded relative humidity sensors in the remote honeycomb cells. The goal of all of these efforts was to help identify reliable sandwich design details, material types, and manufacturing processes that achieve commercial service durability goals for primary structure. In as much as environmental durability studies take significant time, they are expected to continue into Phase C of ATCAS.

Figure 7-38 shows some key results found to date in Boeing sandwich durability studies. Tests were performed to evaluate how the cells in a honeycomb panel respond to fluctuating environments. Some of the honeycomb cells were directly exposed to the environment, as is possible in service when local damage occurs, while the internal behavior of remote cells with sealed facesheets was monitored.

Flight Cycle Test - Phase II: Single Cycle Thermal Exposure
(holding pressure constant at 2.15 psia, with no humidity)

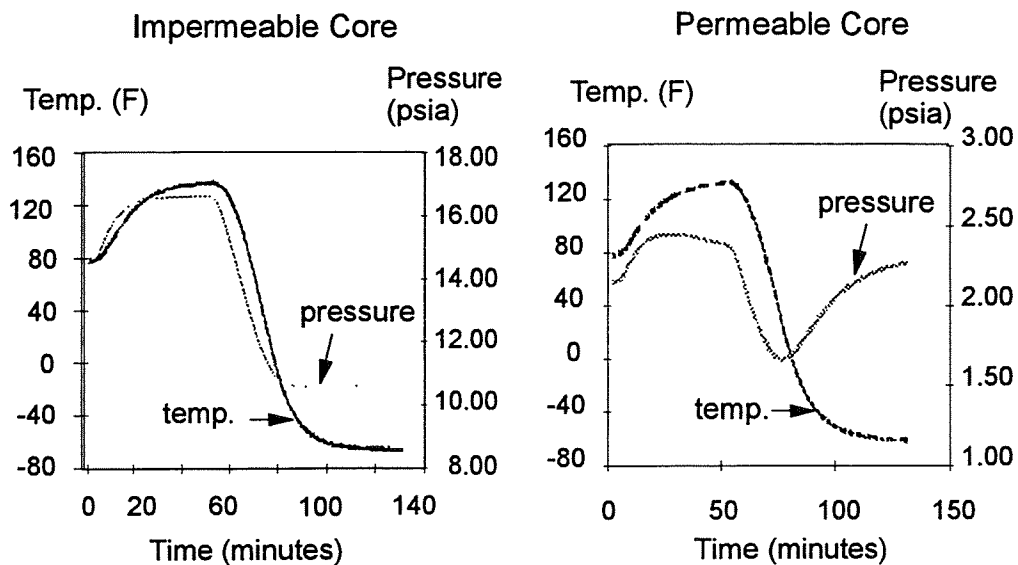

Figure 7-38: Sandwich panel water ingress studies.

In the set of experiments shown in Figure 7-38, the internal pressure and temperature of remote honeycomb cells was monitored while the entire panel was subjected to an environment with constant outside pressure and variable temperature. Note that the internal response of a core material with cell walls judged to be impermeable to air behaved as an ideal gas trapped inside a constant volume (changes directly related to temperature variations) while a "permeable core" had internal pressure which constantly tended to equilibrium with the chamber. These results suggested that permeable cores may have an accelerated moisture transport mechanism in which moisture vapor and condensed water in exposed cells can be pumped throughout the honeycomb panel while pressure equilibrium is reached during aircraft landing. Additional details on these studies are given in reference 11.

X-rays were taken periodically for the Boeing water ingestion panels subjected to ground/air/ground cycles. After more than 500 cycles, X-rays indicated traces of water ingestion in some of the cells adjacent to exposed cells in most samples tested. The permeable cells had more penetration than those that were not permeable; however, the rate of movement was slow in all cases. Data available at the end of Phase B was not able to distinguish whether the slow migration was related to natural diffusion processes or a breakdown in the honeycomb cell wall as a function of freeze/thaw mechanisms. Additional confusion came in experimental evidence suggesting greater tendencies along one area of the cells directly exposed to the moisture source, as opposed to other areas that were also exposed. Continued measurements of the resistance to moisture movement into Phase C of ATCAS should prove important in defining inspection intervals for sandwich design detail.

Long term tests performed at the University of Iowa, without cyclic temperature and humidity conditions, suggested that moisture transport between impermeable honeycomb cells is a very slow process (reference 64). Tests involving thermal spikes and permeable core had somewhat different response than those performed with baseline materials and constant temperatures. Diffusion analysis for cellular solids such as composite honeycomb panels should be performed in the future to help model these transport processes. In addition to supporting an understanding of moisture vapor and liquid water ingestion, such analyses would also help predict the time required for extraction prior to bonded sandwich repair.

7.4.3 Repair

The development of structural repair procedures for ATCAS designs began in 1992. American Airlines maintenance personnel played an important role in these developments. The baseline repair processes for hat-stiffened crown and sandwich keel designs involved bolted and bonded procedures, respectively.

An American Airlines mechanic is shown performing the bolted repair for an ATCAS crown panel in Figure 7-39 (ref. 58). Repair designs for this panel required significant F.E. analysis as part of a subcontract performed at Oregon State University. This effort was also supported by repair coupon tests. The F.E. analyses, coupon test results, and analysis correlations from this work are documented in reference 56. The panel shown in Figure 7-39 is currently waiting to be tested in the pressure box at NASA Langley.

The crown was the only ATCAS fuselage quadrant that did not establish maintenance procedures until after base structural designs for manufacturing scaleup were set, resulting in unnecessarily complex repair designs and processes (refs. 56 and 58). A change to the stiffer crown design discussed in Section 5.1 would eliminate this complexity, restating the need to consider maintenance early in the design process.

Figure 7-40 shows sandwich bonded repair trials performed at American. Similar repairs were completed for a 30-ply mid keel panel which was tested in uniaxial compression at NASA (ref. 59). In order to avoid large scarf angles for bonded patch repairs to sandwich panels with thick facesheets, F.E. analysis supported the development of mid keel repair

designs. These analyses and the mid keel compression test performed at NASA Langley are also documented in reference 56.

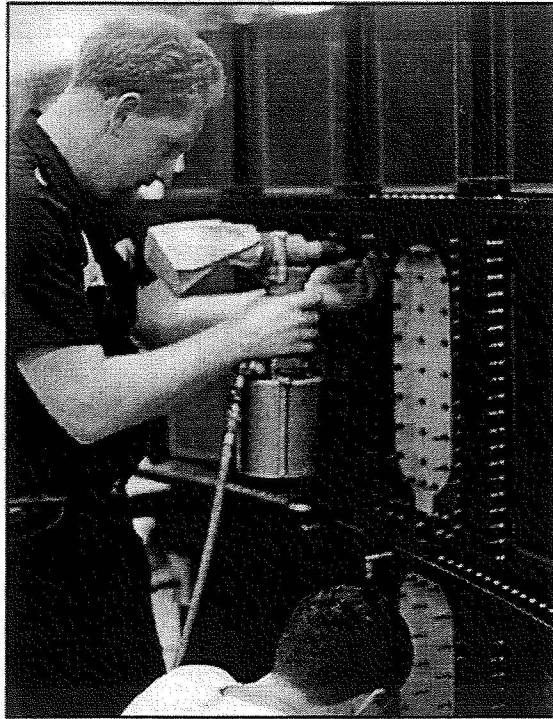

Figure 7-39: Aft crown bolted repair at American Airlines.

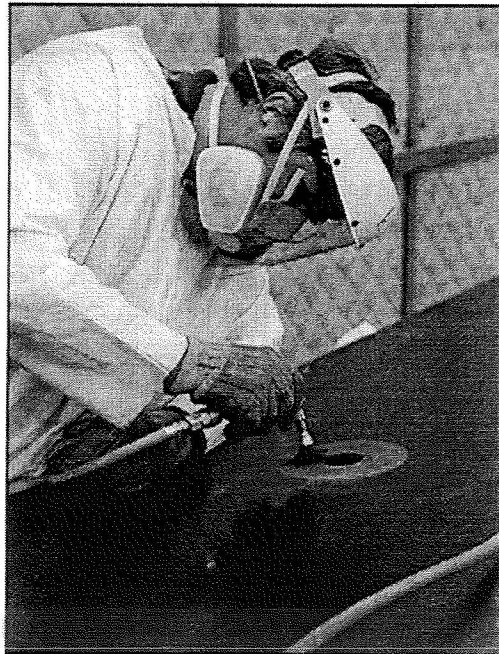

Figure 7-40: Mid keel bonded repair at American Airlines.

7.5 Design Cost Model Development

Since the start of the ACT program, cost has been the top issue to resolve for expanded composite applications. Past composite development approaches of optimizing structural weight prior to addressing manufacturing methods has traditionally resulted in costly designs. As discussed in Section 4.3, ATCAS has considered material and manufacturing costs as a major part of the design process throughout Phases A/B of the program. Materials must be selected to balance performance and cost. The development of cost-effective manufacturing processes is also not sufficient to guarantee low costs. Parallel design efforts must focus on concepts that ensure the efficient use of these processes. The issues are not limited to recurring costs. Manufacturing process efficiencies can strongly affect overall factory flow, and the associated rate tooling and factory space requirements.

Cost prediction tools, including documented methods, software, and the required databases, can benefit each stage of design development. Numerous recent publications have suggested that the majority of production costs are set by early design decisions. Although it is hard to argue with such a statement, it may be better to state that *the lower limit of production costs are strongly affected by early decisions*. Preliminary tools can be used to select concepts and guide cost-effective composite developments. However, it is crucial that such tools evolve with an integrated database to capture a thorough understanding of the desired design details for efficient factory flow. Fabrication costs can be adversely affected by incorporating local design details that are incompatible with the chosen manufacturing processes. Established cost prediction tools are needed for accurate and timely DBT support during production design definition when a program attempts to *achieve the lower limit of production costs while optimizing product value for each customer's needs*.

The ATCAS program began work on a design cost model in 1990. Original efforts were performed by Boeing and a subcontract with the University of Washington. The original software developed was called UWCODA. In 1991, this effort was expanded in a modification to the ATCAS contract (see ref. 13). Objectives for this effort included:

- i) develop an understanding of design details critical to manufacturing cost,
- ii) develop a theoretical framework, general enough to model design/cost relationships for both current and evolving processes,
- iii) incorporate design constraints to help ensure concepts analyzed for cost are also structurally sound,
- iv) develop methods to analyze the effects of design details on manufacturing tolerances and add appropriate model constraints,
- v) develop and adapt a "blending function" which enables the model to cost-effectively blend design details over variations in load,
- vi) combine i) through v) into a software package called Cost Optimization Software for Transport Aircraft Design Evaluation (COSTADE), and
- vii) verify the design cost model with available data,

The code UWCODA was expanded to meet these objectives and renamed COSTADE.

Figure 7-41 shows the many facets of COSTADE that relate to cost and product value. Cost modules directly predict the effect of design variables on fabrication and assembly costs. Manufacturing and blending modules constrain the design within acceptable producibility limits, controlling point to point design variation, panel warpage, and tolerance stack-up. Weight assessments can be coupled with cost to pursue designs with optimum product value. Other modules provide utilities for efficient design development, affecting the nonrecurring costs related to cycle time. Subcontracts with Massachusetts Inst. of Tech. (MIT), Univ. of Washington, Sikorsky Aircraft, Northrop/Grumman Corp., and Dow-UT have supported Boeing in this effort.

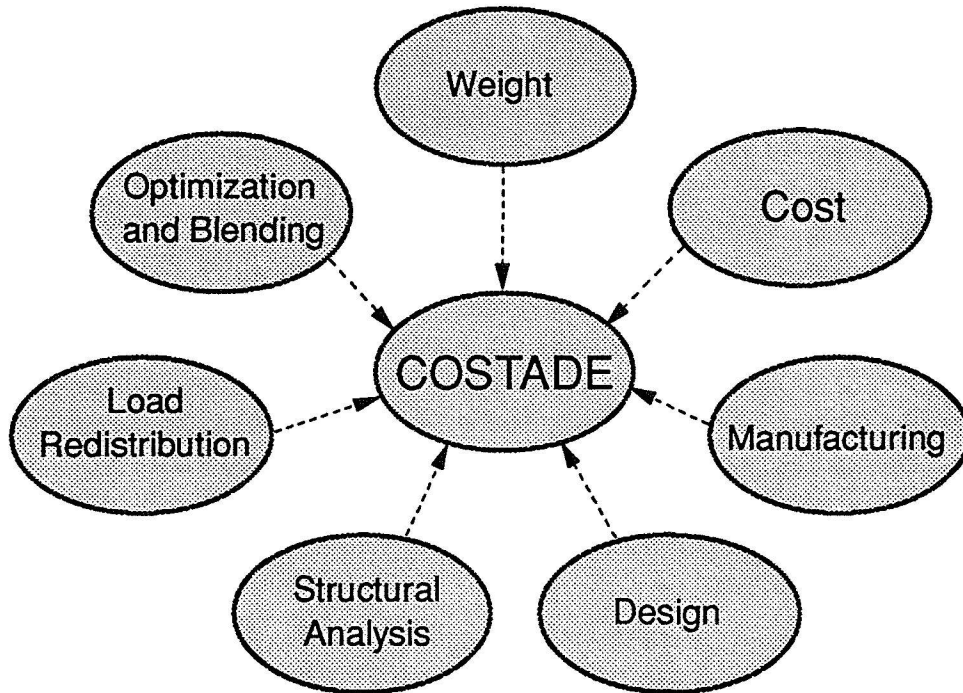

Figure 7-41: Cost Optimization Software for Transport Aircraft Design Evaluation

Four contractor reports were compiled at the end of Phase B to document the COSTADE initiative. As a result, summary discussions contained in the following subsections have been abbreviated. A more complete overview of COSTADE, which focuses on its capabilities and applications, is given in reference 14. Theoretical framework developed in ATCAS for design cost assessment, including (a) the mathematical basis established at MIT, (b) approach to characterize the processes in a selected factory, and (c) composite fuselage results, is documented in reference 10. The COSTADE users manual and ATCAS process cost analysis database are presented in references 15 and 37, respectively.

7.5.1 Theoretical Framework

One of the most important benefits of the COSTADE initiative has been interactions between team members with diverse backgrounds. Figure 7-42 provides an overview on the expected evolution of cost models during Boeing development stages leading to

production. The framework established to mature advanced technology through stages of development is integrally related to the DBT approach used in ATCAS (reference 10). Insights derived during COSTADE development have been used to help define a process, whereby strong company interactions between structures, manufacturing, finance, and facilities organizations are required to efficiently generate the necessary cost databases.

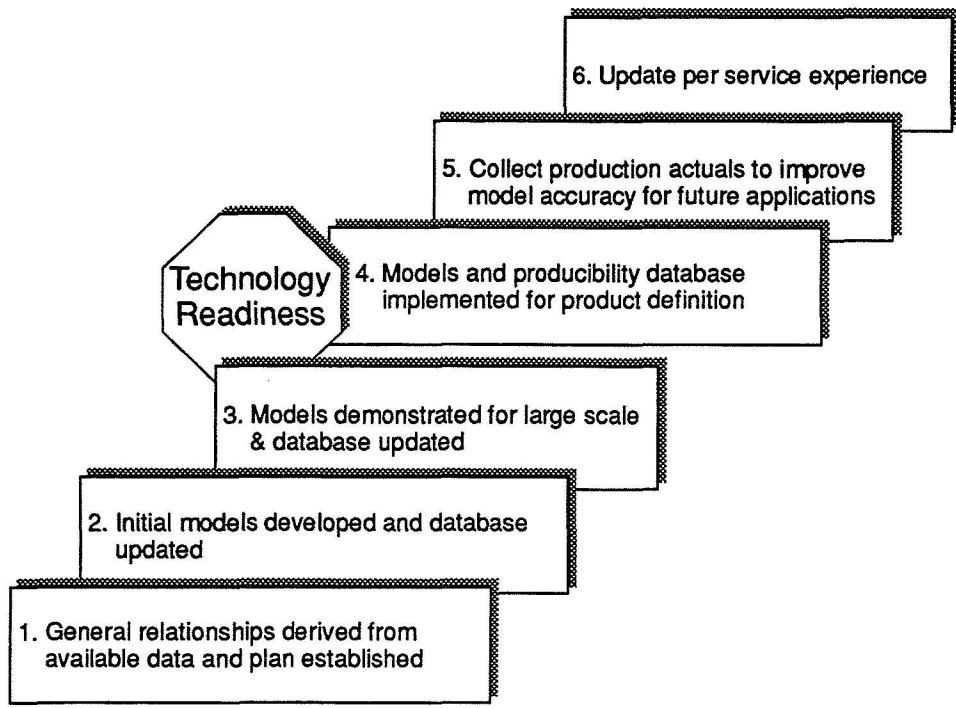

Figure 7-42: Stages of cost model development.

Applications for a design cost model change with the stages of development and product implementation shown in Figure 7-42. As described in Figure 7-43, three main types of applications are envisioned, each crucial to guiding the DBT at different stages. Early applications for a design cost model (i.e., Stages 1 and 2) focus on quantifying benefits of the technology and guiding developments. Approaching the implementation of a particular product (i.e., Stages 3 and 4), the model will help optimize the design configuration and define the manufacturing facility. Finally, a design cost model can help complete product definition with an assessment of how specific design details affect process flow and the resulting manufacturing cost.

Past industrial cost models have generally been empirical, lacking a theoretical basis. Therefore, their application to advanced technology that has little database were limited. The development of mathematical theories linking manufacturing cost to design variables were pursued in a MIT subcontract (refs. 10, 65-67). Equations with common functional forms were developed and procedures were identified for determining coefficients that have physical meaning. The combined mathematical basis and recommended procedures to create and update cost equations provide the theoretical framework for cost assessment of advanced technology (ref. 10). This effort has also provided a non-proprietary,

educational basis that should prove useful for training and communication between different disciplines involved in the various stages of development.

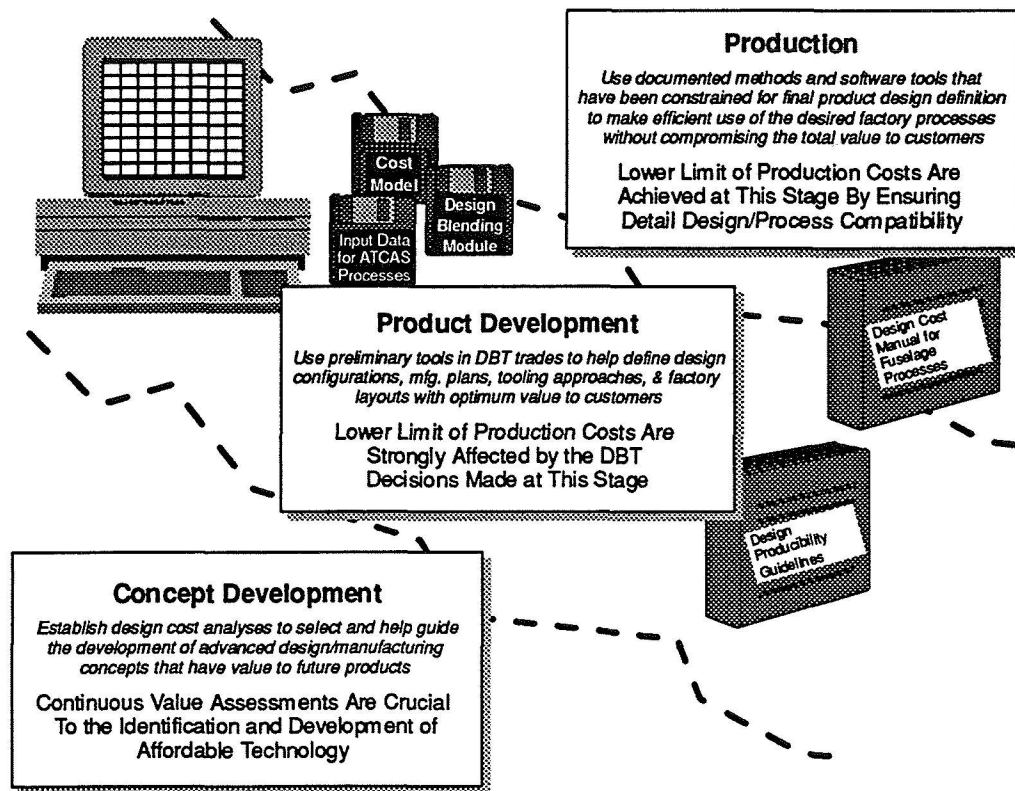

Figure 7-43: Three Applications of a Design Cost Model.

7.5.2 ATCAS Cost Database

Initial cost assessments for each ATCAS quadrant were based on projected material costs and comprehensive manufacturing plans. Each process (e.g., AFP, core machining) was subdivided into steps (e.g., tool cleaning, hole drilling), and cost predictions for each step extrapolated from existing data, where available, or estimated using physical insights. Some preliminary factory simulations determined tooling, machine, and space requirements. Using groundrules (see Table 6-1) established early in the ACT program, quadrant costs were generated through the summation of individual cost elements. As discussed in Section 6-1, credible comparative estimates for state-of-the-art metallic structure were generated to evaluate progress towards achieving cost and weight targets.

As part of the COSTADE initiative, Boeing and MIT have converted over two hundred process-step based relationships to a consistent mathematical basis. The first-order equation forms used for most of these equations are shown in Table 7-1. Equation sets which represent the ATCAS factory were used to predict composite costs presented in Section 6.2. As a result, detailed estimates that took several months to perform in past ATCAS trade studies have been replaced by a design cost model that provides timely and repeatable results.

$$t \approx \left[\left(\frac{\text{Setup}}{\text{Run}} \right) + \left\{ \left(\frac{\text{Delay}}{\text{Operation}} \right) + \sqrt{\left(\frac{x}{v_o} \right)^2 + \left(\frac{2\tau}{v_o} \right) x} \right\} \left(\frac{\text{Operations}}{\text{Run}} \right) \right] \frac{(\text{Parts}/\text{Shipset})}{(\text{Lots}/\text{Run})(\text{Parts}/\text{Lot})}$$

$$t \approx \left[\left(\frac{\text{Setup}}{\text{Run}} \right) + \left\{ \left(\frac{\text{Setup}}{\text{Ply}} \right) \frac{\text{Plies}}{\text{Run}} + \frac{x_1}{v_{o1}} + \frac{x_2}{v_{o2}} + \frac{x_3}{v_{o3}} \right\} \right] (\text{Runs}/\text{Shipset})$$

Table 7-1: *Most common process step equations used in the ATCAS cost analysis database (ref. 37).*

The theoretical basis and process cost analysis database established for composite fuselage designs will allow the ATCAS DBT to continue maturing cost insights. The equations in Table 7-1 can be used to predict labor times for either individual or accumulated process steps. Labor rates are used to convert times to dollars. The ACT cost estimating groundrules do not explicitly account for equipment and facilities. Instead wrap rates of \$100/hour and \$75/hour were used for recurring and nonrecurring labor, respectively. At Boeing and other companies, equipment and facilities costs are an important part of the decision process for developing and implementing new technologies such as composites. During the development of cost models and database preprocessors for COSTADE, allowances were made to expand the tool beyond ACT cost groundrules in future applications. As shown in the product development application in Figure 7-43, design cost models are recommended in support of resource planning.

Each process-step equation developed for ATCAS are based on design variables (e.g., part geometry and weight) critical to the resulting costs. Detailed estimates generated during quadrant cost trades and relevant existing data supported characterization of the model coefficients. Figure 7-44 shows the key design variables affecting total ATCAS costs. A complete documentation of the variables can be found in references 10 and 37.

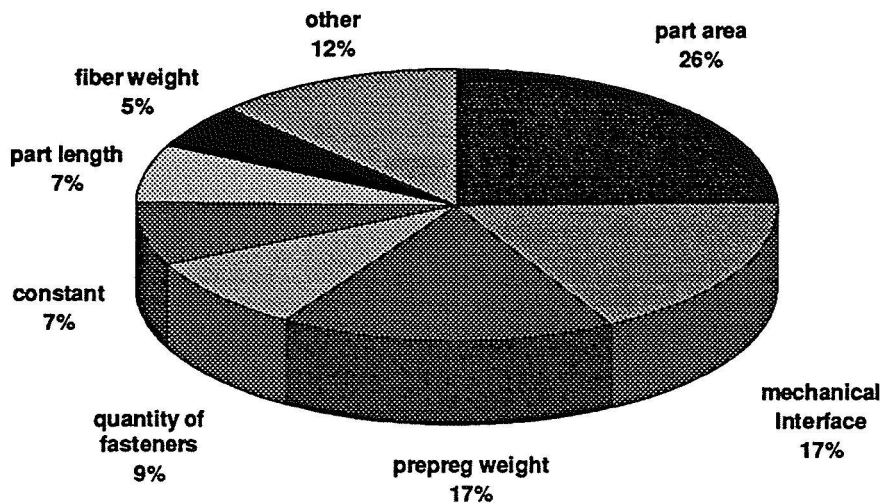

Figure 7-44: *The percentage of total costs per design variable type.*

Example results from an ATCAS cost equation used for ply layup in the AFP process are shown in Figure 7-45. The curves in this figure plot process labor times for the same ply area but different ply aspect ratios. Note the relationship between ply angle and process time changes as a function of ply geometry, indicating significant interaction.

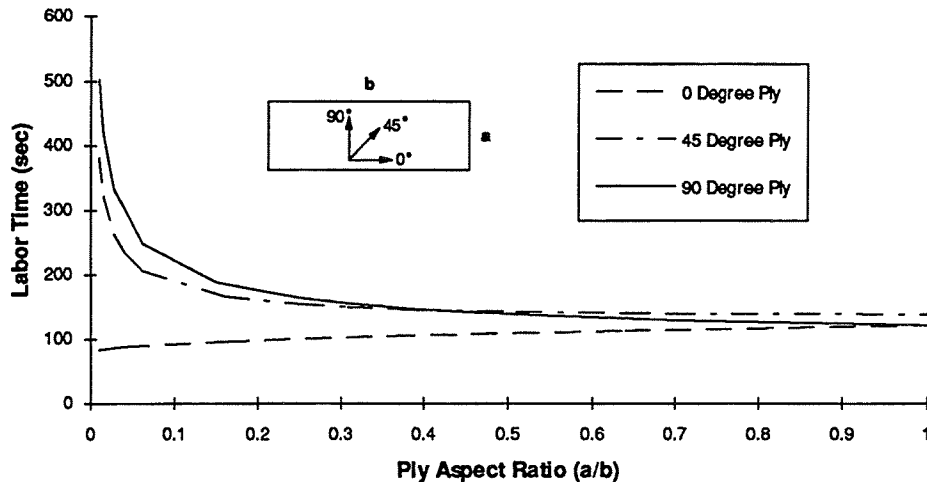

Figure 7-45: Labor required for AFP layup has been characterized as a function of ply shape and ply orientation.

7.5.3 COSTADE Software Utilities

As shown schematically in Figure 7-41, the software tool called COSTADE supports many aspects of cost-effective and efficient design optimization. Cost, manufacturing, and structural algorithms within COSTADE use existing skin/stringer and sandwich databases to ensure structural integrity and manufacturability. Blending modules combine a series of point designs into a compatible panel definition. Multiple loading conditions and discrete characteristics of design variables associated with composite structures (e.g., integer number of plies) are accommodated. Links to FE loads models allow the effects of stiffness changes on load distributions to be addressed during the optimization process.

Blending and optimization software utilities developed for COSTADE at the University of Washington are worthy of special mention (refs. 68 and 69). The top of Figure 7-46 describes some benefits attained from these utilities, which enable DBTs to simultaneously assess the cost and weight of viable designs that meet structural requirements.

Blending has been crucial to allowing the practical cost and weight optimization of producible structural designs. The blending utility effectively links design details to cost predictions, point by point structural analyses, and other model constraints. The primary issue that blending helps solve is that costs are calculated over the continuous surface of a component while stress analyses are performed to determine the margins of safety at points in the loads space. In design optimization, point by point selection of design detail must recognize how structural continuity affects producibility and cost. Blending utilities help to select local design details based on what is optimum for the panel as a whole.

- Ensures producible designs
- Multiple load cases & M.S. checks
 - e.g., 220 element side design
- Large reduction in cycle time
- Links to internal loads analyses will yield additional efficiencies

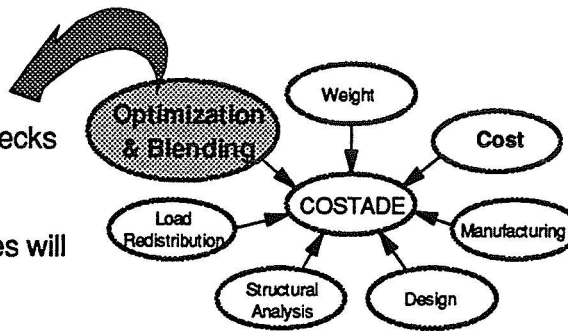

Crown Panel Designs

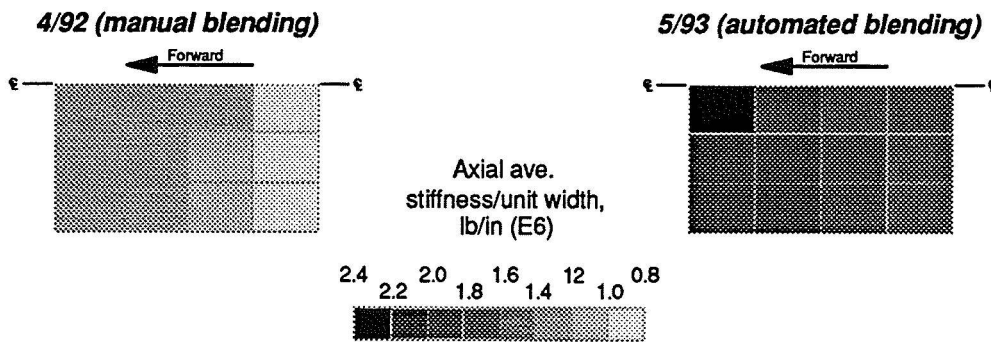

Figure 7-46: Blending structural designs.

The ability to perform local analyses that recognize the effects of neighboring points is crucial to the design of affordable aircraft structure. Initial COSTADE analyses performed in ATCAS were labor intensive and required manual blending of designs. The bottom of Figure 7-46 shows crown panel designs generated in 1992 (ref. 12) and in 1993 (ref. 17) using manual and automated blending, respectively. The former effort required significant amounts of design constraint and took roughly 10 times as long to complete. This example helps to illustrate the advantages of COSTADE blending capabilities.

One of the primary schedule, manpower, and manufacturing cost drivers occurring during production design relates to the time-consuming iterations that occur with internal loads analyses. Efforts supporting ATCAS fuselage design near the end of Phase B developed a link between global internal loads analyses and COSTADE design optimization (refs. 18, 14, 15, 70, and 71). The related longterm goal is to establish guidelines, procedures, and software utilities that allow rapid iteration between internal load updates and design refinement. Note that the two designs in Figure 7-46 resulted in significant differences in the axial crown panel stiffness. Although the two were designed to the same original internal loads, one or both will cause significant changes in these loads after iterating new crown stiffness in the global fuselage model. This example is particularly relevant to the ATCAS crown design discussed in previous sections. Desirable benefits in manufacturing, damage tolerance, repair, and bonded frame strength occur with the relatively stiff crown design; however, shifts in the internal load must be evaluated.

The optimization capability of COSTADE allows rapid exploration of the complex interactions associated with aircraft design criteria, fabrication cost, manufacturing constraints, and structural weight. It has been successfully used to determine important cost trends for major design variables, evaluate differing load redistribution methods, select initial configurational details (e.g., layups), and quickly refine designs for updated loads and test results. For example, COSTADE optimization results in Figure 7-47 show how cost and weight changes as a function of stiffener spacing (ref. 12).

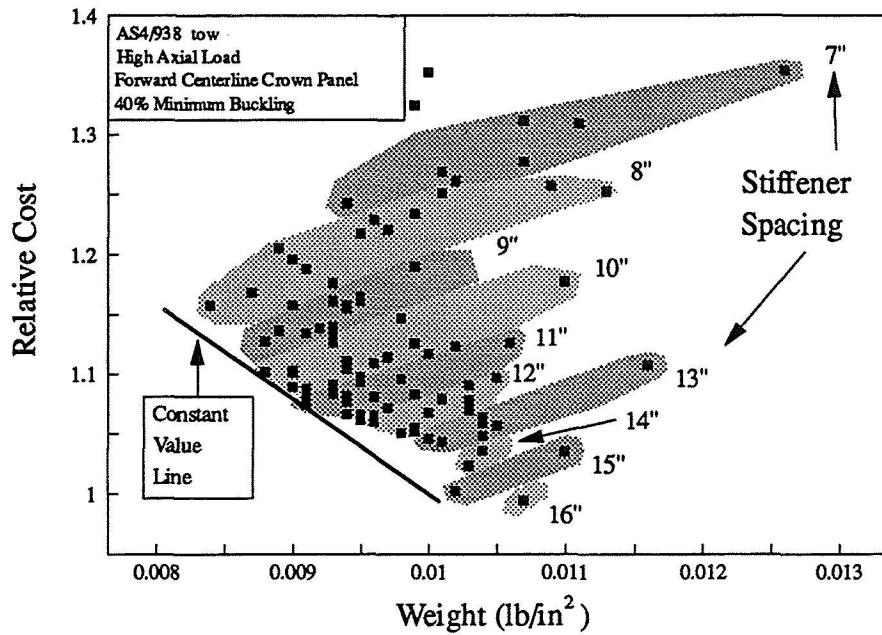

Figure 7-47: COSTADE crown panel analyses identified important cost/weight trends related to stiffener spacing.

8.0 CONCLUDING REMARKS

8.1 Benefits of Integrated Product Development

The integrated approach used for technology development in the ATCAS program matured over time. Figure 8-1 lists seven guidelines that were derived based on ATCAS experiences. Many of these formed a basis for Boeing's initiatives discussed in Section 3.2.1 to stage composite structural development.

The first guideline in Figure 8-1 relates to continued cost evaluation of the composite technology as it is developed. Manufacturing, structures, and maintenance insights will improve as technical issues are resolved and the database expands. Changes in the Total DOC versus state-of-the-art aluminum is a good measure of the success of each stage of development. The second, third, and fourth guidelines suggest that design details should be addressed early in manufacturing and maintenance development efforts. Technology in each functional area should also mature at the same rate, instead of developments in series (e.g., repair issues should be addressed from the start). In addition, scale-up and repetitive demonstrations provide valuable data that should be collected as early as feasible.

1. *Continuous total cost assessment is crucial*
2. *Consider design detail and manufacturing scale-up early in process development*
3. *Critical evaluation of manufacturing and maintenance issues must support design decisions at each stage of development*
4. *Perform multiple fabrication and repair trials with critical details*
5. *Strong manufacturing-induced performance traits have been noted for advanced composite processes*
6. *Building block tests/analysis should consider the largest structural scale feasible early in design development*
7. *Design cost model that integrates functional databases has potential to be a very useful tool for hardware applications*

Figure 8-1: Guidelines established from integrating functional efforts in the ATCAS program.

The fifth and sixth guidelines in Figure 8-1 relate to ATCAS experiences in evaluating fuselage structural issues. For example, processes such as AFP were found to yield differing fracture properties that became most evident in the largest scale of mechanical

testing. Numerous other examples of links between manufacturing processes and structural performance can also be given. As is the case for metal aircraft structure, findings from ATCAS reinforce the need for integrated development of manufacturing processes and structural details.

The final guideline in Figure 8-1 relates to ATCAS developments of design cost utilities (methods, databases, and software tools, e.g., COSTADE and PCAD). As the ATCAS database expanded, these utilities have been updated to support a DBT in each stage of design/manufacturing refinement. Future enhancements, in preparation for composite fuselage applications, will continue to focus on timely analyses that ensure a program can efficiently meet cost- and weight-saving goals.

8.2 Current Status

All program goals established in the contract were met by the end of ATCAS Phase B. Figure 8-2 shows ATCAS progress in the staging procedure used by Boeing to judge technology readiness (see Section 3.2.1). As shown, all functional areas have been addressed in parallel, yielding similar levels of technology status. A more detailed assessment of the progress in each functional area is given in the other Contractor Reports documenting ATCAS Phase A/B results (see notes in Figure 8-2).

Stage	Initial Concept	Concept Development	Large-Scale Development	Product Development	Production (reduced cycle design/build)	Product Support
Functional Technology	<i>Representative Development Application</i>			<i>Production Application</i>		
Cost Evaluation <i>(details in refs. 10, 14, 15, & 37)</i>	●	◐	○	○	○	○
Structural Design <i>(details in refs. 6 & 11)</i>	●	◐	○	○	○	○
Manufacturing <i>(details in ref. 8)</i>	●	◐	○	○	○	○
Maintenance <i>(details in ref. 56)</i>	●	◐	○	○	○	○

Key		
●	◐	○
Complete	Active	Not Started

Figure 8-2: Maturity of enabling composite fuselage technology.

The purpose of this entire Contractor Report was to overview Phases A and B progress in the ATCAS program. Figures 8-3 through 8-5 summarize the program further as broken into three main categories: manufacturing, structures, and design cost model developments. Note that material/process and maintenance issues are addressed under both manufacturing and structures headings.

Manufacturing Developments (Including fabrication and repair processes)

- **Hard OML/soft IML cure tooling demonstration for skin/stiffened and sandwich designs**
- **Stiffened crown panels scaled to 7 ft. x 10 ft.**
 - Semi-rigid IML tooling for intricate panel bond with pre- & uncured elements; accommodates design changes (patent received in 1993)
 - Joint Hercules/Boeing AFP studies for curved panels including graphite/glass intraply hybrids
 - Braided/RTM frames fabricated with sufficient tolerance control to enable cobonding
 - Efficient hat-stringer drape forming and tooling approach
 - Manufacturing tolerance database for a range of design variables
 - Repetitious panel and element fabrication to optimize process steps
- **Mechanically attached crown repair demonstration supported by American Airlines**
- **Forward, mid, and aft sandwich keel panels scaled up to approximately 7 ft. x 10 ft.**
 - Semi-rigid IML tooling for sandwich panel bond with pre-cured elements
 - Cure cycle & material specifications to fabricate structure transitioning from thick laminate to sandwich
 - Braided/RTM close-outs for splices and tolerance control of panel edges
 - Interface with Lockheed ACT contract in optimizing frames for sandwich designs
 - High density honeycomb core forming/splicing/stabilization schemes
- **Bonded repair demonstration for mid keel panel (30 ply facesheets), supported by American Airlines**
 - Temporary and permanent bonded repair trials for keel sandwich panels
- **Window-belt sandwich panels scaled to 7 ft. x 10 ft.**
 - Semi-rigid IML tooling for sandwich panel bond with pre-cured elements (circumferential frames & window close-outs)
 - Joint Hercules/Lockheed/Boeing AFP studies for full-depth & ramped cutout designs
 - Honeycomb core machining/forming/splicing/stabilization schemes for maximum tolerance payoff
- **Warpage analysis methodologies to support cured panel tolerance control**
 - Simulate as-cured configured panels, including edge effects and cutouts, to achieve attachment and splice payoff

Figure 8-3: Manufacturing highlights from ATCAS Phases A & B.

Structures Developments (including material performance & maintenance procedures)

- **Designed structural experiment & supporting analyses for impact damage**
 - Stiffened design, material, laminate, and impact variables critical to damage states
 - Flexural wave NDE approach to quantitative damage characterization
 - Recommended approach to revise impact design criteria for affordable supportability (allowable damage limits for repair and critical damage thresholds for damage tolerance)
- **Crown database**
 - Manufacturing-induced structural properties noted for AFP and braided processes (e.g., large notch tensile strength)
 - Tensile strength (small notch) versus toughness (large notch) trade for laminate, manufacturing process, and material combinations
 - Axial and hoop damage tolerance panel tests/analyses confirmed crown designs with bolted frames
 - Demonstrated extension of unconfigured fracture data to predict configured panel response using semi-empirical methods
 - Compression element and panel stability tests/analyses confirmed crown designs with bonded frames
 - Bonded frame pull-off and pressure-box studies uncovered issues with bonded frame details (i.e., bondline integrity near mouseholes & soft skin layup under high axial load cases)
 - Repair building block tests and analysis supported the design of a mechanically-attached patch repair for large penetrating damage
- **Keel database**
 - Notched compressive strength did not benefit from enhanced matrix toughness but did seem to depend on laminate thickness
 - Minimum-gage sandwich design found to have sufficient impact resistance and compression after impact properties
 - Large notch compression strength found to be a design driver (experimental/analysis procedures for measuring compression scaling laws)
 - Bonded frame pull-off and push-in found to be sufficient for sandwich panel pressure pillowing and stability, respectively
 - Aft keel building block tests/analysis methods were verified by structural test with a large curved sandwich panel
 - Mid keel analysis supported the design of bonded patch repairs verified by structural test with a large curved sandwich panel
 - Forward keel analysis and tests evaluated load redistribution and effects of structural details on strength, leading to large test panel design
- **Side database**
 - Large and small notch database generated for compression, tension, laminate and sandwich variables supporting side design
 - Test evaluation of sandwich design resistance to moisture ingress and migration and panel in-plane moisture vapor transport
 - Structural analysis and pressure-box test demonstrated performance of sandwich window-belt cutout design details (combined load structural test validation is planned in the NASA COLTS facility)
- **Initial test database and analysis to evaluate splice mechanical strength and environmental durability of close-out design details**
- **Strain softening analysis for progressive damage growth simulations**
 - Verified scaling accuracy for a range of unconfigured panel sizes and preliminary assessment with structural configurations
- **Cursory evaluation of fire worthiness for fuselage test elements**

Figure 8-4: Structures highlights from ATCAS Phases A & B.

Design Cost Model Developments (including methods, databases, and software)

- Theoretical framework and mathematical basis established for design cost modeling
- Relational database called PCAD (Process Cost Analysis Database) created for equations predicting 80% of the costs of the ATCAS barrel
- General cost algorithm established to accept existing cost models
- Process step level cost equations for ACT processes
- Design software tool called COSTADE (Cost Optimization Software for Transport Aircraft Design Evaluation) created to integrate structural analysis, design cost, and manufacturing tolerance methods
 - Interface for internal loads iterations
 - Practical and efficient software for structural blending & optimization
 - User manual and other support documentation
- Crown, keel, and side applications uncovered cost/weight interactions
 - Captured ATCAS Phase A and B database to support Phase C design

Figure 8-5: Design cost model highlights from ATCAS Phases A & B.

8.3 Recommendations for Future Development

Figure 8-6 lists key deliverables for completing Stage 2 of Boeing's procedures used to judge technology readiness. Benchmark tests at NASA, additional side manufacturing demonstrations, and fuselage splice developments (longitudinal & circumferential) are the main hardware activities needed to complete Stage 2. Documents and software defining recommended cost, design, material, process, and maintenance procedures are also required. Figure 8-6 also lists some of the highlights of large-scale developments for composite fuselage. Note that the Stage 3 activities expand to other fuselage sections. Plans for ATCAS Phase C include efforts to complete much of Stages 2 and 3.

Much of the technology developed by ATCAS also applies to other U.S. composite initiatives. As a result, numerous indirect benefits from the ATCAS contract will be realized long before a composite fuselage enters service. Figure 8-7 highlights some of the

technology that has been shared to benefit other groups, inside and outside Boeing. The Boeing Company is pleased to have been a part of Phases A and B of the ACT program.

What is Needed to Complete Stage 2 ?

- total production facility cost est.
- representative detailed design, subscale mfg. trials, & subcomponent tests for all quadrants & splices
- preliminary design, material, & process documents
- draft SRM

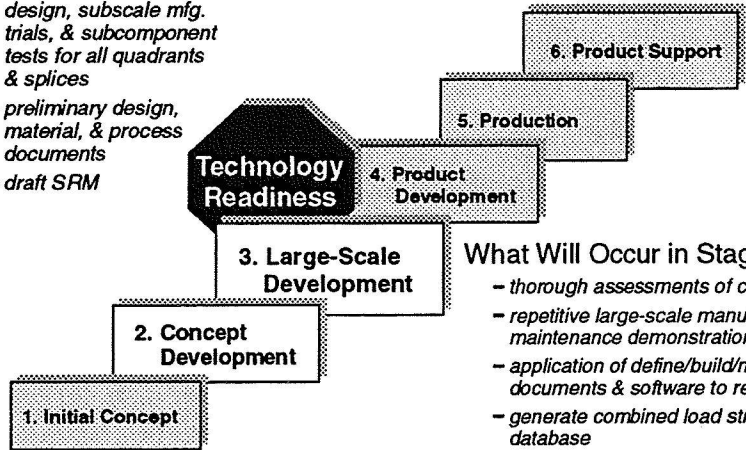

What Will Occur in Stage 3 ?

- thorough assessments of cost credibility
- repetitive large-scale manufacturing & maintenance demonstrations
- application of define/build/maintain documents & software to rest of fuselage
- generate combined load structural database
- achieve airline customer acceptance of maintenance procedures
- apply database to other fuselage sections

Figure 8-6: Transition to large scale development.

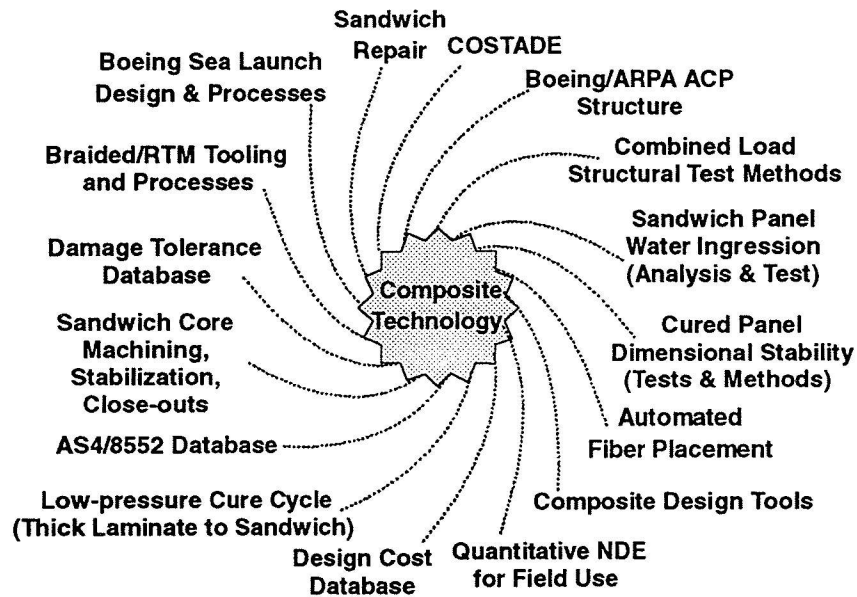

Figure 8-7: Indirect benefits from ATCAS developments.

9.0 REFERENCES

1. Aniversario, R., Harvey, S., McCarty, J., Parsons, J., Peterson, D., Pritchett, L., Wilson, D., and Wogulis, E.: "Design, Ancillary Testing, Analysis, and Fabrication Data for the Advanced Composite Stabilizer for Boeing 737 Aircraft, Volume I - Technical Summary," NASA CR 3648, April, 1983.
2. Aniversario, R., Harvey, S., McCarty, J., Parsons, J., Peterson, D., Pritchett, L., Wilson, D., and Wogulis, E.: "Full Scale Testing, Production, and Cost Analysis Data for the Advanced Composite Stabilizer for Boeing 737 Aircraft, Volume I - Technical Summary," NASA CR 3649, April, 1983.
3. Ilcewicz, L., Walker, T., Willden, K., Swanson, G., Truslove, G., and Pfahl, C.: "Application of a Design-Build-Team Approach to Low Cost and Weight Fuselage Structure," NASA CR 4418, November, 1991.
4. Flynn, B., Morris, M., Metschan, S., Swanson, G., Smith, P., Griess, K., Schramm, M., Willden, K., and Humphrey, R.: "Global Cost and Weight Evaluation of Fuselage Keel Design Concepts," NASA CR 4541, December, 1993.
5. Polland, D.R., Finn, S.R., Griess, K.H., Hafenrichter, J.L., Hanson, C.T., Ilcewicz, L.B., Metschan, S.L., Scholz, D.B., and Smith, P.J., "Global Cost and Weight Evaluation of Fuselage Side Panel Design Concepts," NASA CR-4730, 1997.
6. Walker, T.H., Minguet, P.J., Flynn, B.W., Carbery, D.J., Swanson, G.D., and Ilcewicz, L.B.: "Advanced Technology Composite Fuselage - Structural Performance," NASA CR-4732, 1997.
7. Walker, T., Ilcewicz, L., Bodine, J., Murphy, D., and Dost, E.: "Benchmark Panels," NASA CR-194969, Aug., 1994.
8. Willden, K.S., Flynn, B.W., Gessel, M., Harris, C.G., Scholz, D.B., and Stawski, S., "Advanced Technology Composite Fuselage - Manufacturing," NASA CR-4735, 1997.
9. Ilcewicz, L., Smith, P., and Horton, R.: "Advanced Composite Fuselage Technology," *Third NASA/DOD Advanced Composite Technology Conference*, NASA CP-3178, 1992, pp. 97-156.
10. Ilcewicz, L.B., Mabson, G.E., Metschan, S.L., Proctor, M.R., Tervo, D.K., Fredrikson, H.G., Gutowski, T.G., Neoh, E.T., and Polger, K.C.: "Cost Optimization Software for Transport Aircraft Design Evaluation - Design Cost Methods," NASA CR-4737, 1996.
11. Scholz, D.B., Dost, E.F., Flynn, B.W., Ilcewicz, L.B., Lakes, R.S., Nelson, K.M., Sawicki, A.J., and Walker, T.W.: "Advanced Technology Composite Fuselage - Materials and Processes," NASA CR-4731, 1997.

12. Swanson, G., Ilcewicz, L., Walker, T., Graesser, D., Tuttle, M., and Zabinsky, Z.: "Local Design Optimization for Composite Transport Fuselage Crown Panels," *Second NASA/DOD Advanced Composite Technology Conference*, NASA CP-3154, 1991, pp. 243-262.
13. Freeman, W., Ilcewicz, L., Swanson, G., and Gutowski, T.: "Designers' Unified Cost Model," *Second NASA/DOD Advanced Composite Technology Conference*, NASA CP-3154, 1991, pp. 27-46.
14. Mabson, G.E., Ilcewicz, L.B., Graesser, D.L., Metschan, S.L., Proctor, M.R., Tervo, D.K., Tuttle, M.E., and Zabinsky, Z.B.: "Cost Optimization Software for Transport Aircraft Design Evaluation - Overview," NASA CR-4736, 1997.
15. Mabson, G.E., and Graesser, D.L.: "Cost Optimization Software for Transport Aircraft Design Evaluation - User's Manual," NASA CR-4738, 1996.
16. Swanson, G.D., Metschan, S. L., Morris, M.R., and Kassapoglou, C.: "The Effects of Design Details On Cost and Weight of Fuselage Structures," *Third NASA/DOD Advanced Composite Technology Conference*, NASA CP-3178, 1992, pp. 601-622.
17. Ilcewicz, L., Walker, T., Murphy, D., Dopker, B., Scholz, D., Cairns, D., and Poe, C., Jr.: "Tension Fracture of Laminates for Transport Fuselage Part 4: Damage Tolerance Analysis," *Fourth NASA/DoD Advanced Composites Technology Conference*, NASA CP-3229, 1993, pp. 265-298.
18. Carbery, D., Finn, S., Murphy, D., Dopker, B., Mabson, G., and Hutchinson, M.: "Global/Local Analysis of Internal Load Paths in Support of Composite Fuselage," *Sixth NASA/DOD/ARPA Advanced Composite Technology Conference*, NASA CP-3326, 1996.
19. Avery, W., Flynn, B., Hanson, C., Scholz, D., Murphy, D., Carbery, D., Dopker, B., Williams, A., and Ilcewicz, L.: "Design and Structural Development of a Composite Fuselage Keel Panel," *Fifth NASA/DOD Advanced Composite Technology Conference*, NASA CP-3294, 1995, pp. 463-495.
20. Mabson, G.E., Flynn, B.W., Ilcewicz, L.B., and Graesser, D.L.: "The Use of COSTADE in Developing Commercial Aircraft Fuselage Structures", AIAA-94-1492, *Proceedings of 35th AIAA/ASME/ASCE/AHS/ASC SDM Conference*, Hilton Head, SC, Apr. 18-20, 1994.
21. Gessel, M., Willden, K., Benson, V., and Grant, C.: "Manufacturing Development for Advanced Fuselage Keel Structure," *Tenth DOD/NASA/FAA Conference on Fibrous Composites in Structural Design*, Hilton Head, SC, Report # NAWCADWAR-94096-60, Nov. 1-4, 1993.
22. Scholz, D., Nelson, K., Avery, W., Flynn, B., Eastland, C., Stobbe, D., Hubert, P., Johnston, A., and Poursartip, A.: "Material and Process Developments for Composite Fuselage Sandwich Structure," *Fifth NASA/DOD Advanced Composite Technology Conference*, NASA CP-3294, 1995, pp. 257-284.

23. Skolnik, D., Shukla, J., Harris, C., and Wheeler, M.: Fabrication and Manufacturing Development of Composite Fuselage Window-Belt Structure, Sixth NASA/DOD/ARPA Advanced Composite Technology Conference, NASA CP-3326, 1996.
24. Barrie, R., Chu, R., Ott, M., and Osborne, P.: Fuselage Side Panel Development, Design Trade Studies, Sixth NASA/DOD/ARPA Advanced Composite Technology Conference, NASA CP-3326, 1996.
25. Jackson, A.: Development of Textiles for Aircraft Primary Structures - An Overview, Sixth NASA/DOD/ARPA Advanced Composite Technology Conference, NASA CP-3326, 1996.
26. Shukla, J., Chu, R., Skolnik, D., and Wu, S.: Recent Advances in Resin Transfer Molding of Textile Preforms, Sixth NASA/DOD/ARPA Advanced Composite Technology Conference, NASA CP-3326, 1996.
27. Polland, D., Walker, T., Smith, P., Griess, K., Dopker, B., and Russell, S.: Structural Development of Composite Fuselage Cutouts: Windowbelt and Door Reinforcements, Sixth NASA/DOD/ARPA Advanced Composite Technology Conference, NASA CP-3326, 1996.
28. Willden, K., Stawski, S., Harris, C., Hafenrichter, J., Grant, C., Brown, T., and Skolnik, D.: "Composite Fuselage Manufacturing Development," *Fifth NASA/DOD Advanced Composite Technology Conference*, NASA CP-3294, 1995, pp. 237-255.
29. Willden, K., Biornstad, R., Harris, C., Stawski, S. and Skolnik, D.: Fabrication for Cost Effective Composite Fuselage Barrel Assembly. Sixth NASA/DOD/ARPA Advanced Composite Technology Conference, NASA CP-3326, 1996.
30. Harris, C., Willden, K., Matetich, R., Stawski, S., Harris, T., and Skolnik, D.: Manufacturing Development of Composite Fuselage Panels. Sixth NASA/DOD/ARPA Advanced Composite Technology Conference, NASA CP-3326, 1996.
31. Smith, P., Ilcewicz, L., and Olson, J.: Advanced Technology Composite Fuselage. *Fifth NASA/DOD Advanced Composite Technology Conference*, NASA CP-3294, 1995, pp. 1-32.
32. Griess, K., Hafenrichter, J., Humphrey, R., Metschan, S., Parkin, G., Polland, D., and Chu, R.: Design Development of a Composite Fuselage Side Panel, *Fifth NASA/DOD Advanced Composite Technology Conference*, NASA CP-3294, 1995, pp. 497- 524.
33. Hanson, C., Griess, K., Flynn, B., Mabson, G., Polland, D., Walker, T. and Dopker, B.: Design Integration of a Composite Aft Fuselage Barrel Section, Sixth NASA/DOD/ARPA Advanced Composite Technology Conference, NASA CP-3326, 1996.

34. Willden, K., Gessel, M., Davies, T., Mabson, G., Grant, C., and Brown, T.: Fuselage Crown Manufacturing Technology Verification, *Fourth NASA/DOD Advanced Composite Technology Conference*, NASA CP-3229, 1993, pp. 95-123.
35. Olson, J., Smith, P., and Ilcewicz, L.: Advanced Composite Fuselage Technology. *Tenth DOD/NASA/FAA Conference on Fibrous Composites in Structural Design*, at Hilton Head, SC, Report # NAWCADWAR-94096-60, Nov. 1-4, 1993.
36. Wong, R.: Sandwich Construction in the Starship, *37th International SAMPE Symposium*, Mar. 1992, pp. 186-197.
37. Proctor, M., and Metschan, S., Cost Optimization Software for Transport Aircraft Design Evaluation - Process Cost Analysis Database (PCAD) v. 2.0 User's Manual, CR-4739, 1996.
38. Dopker, B., Ilcewicz, L., Murphy, D., and Biornstad, R.: Composite Structural Analyses Supporting Affordable Manufacturing and Maintenance, *Sixth NASA/DOD/ARPA Advanced Composite Technology Conference*, NASA CP-3326, 1996.
39. Walker, T., Scholz, D., Flynn, B., Dopker, B., Bodine, J., Ilcewicz, L., Rouse, M., McGowen, D., and Poe, C., Jr., Damage Tolerance of Composite Fuselage Structure, *Sixth NASA/DOD/ARPA Advanced Composite Technology Conference*, NASA CP-3326, 1996.
40. Walker, T.H., Avery, W.B., Ilcewicz, L.B., Poe, C.C., Jr., and Harris, C.E., Tension Fracture of Laminates for Transport Fuselage - Part I: Material Screening, *Second NASA Advanced Composite Technology Conference*, NASA CP-3154, 1991, pp. 197-238.
41. Walker, T.H., Ilcewicz, L.B., Polland, D.R., and Poe, C.C., Jr., Tension Fracture of Laminates for Transport Fuselage - Part II: Large Notches, *Third NASA Advanced Composite Technology Conference*, CP-3178, 1992, pp. 727-758.
42. Bazant, Z., and Cedolin, L., *Stability of Structures*, Oxford University Press, 1991.
43. Russell, S.R., Hangen, J., and Palm, T.E., A Weight-Efficient Design Strategy for Cutouts in Composite Transport Structures, *Third NASA Advanced Composite Technology Conference*, CP-3178, 1992, pp. 879-897.
44. Johnson, E.H., and Venkayya, V.B., Automated Structural Optimization System (ASTROS), USAF Contract report AFWAL 88-TR-88-3208, Vol. 1 - Theoretical Manual, 1988.
45. Cohen, D., Cairns, D.S., Avery, W.B., and Abdallah, M.G., Analysis and Testing of Thick Automated Tow Placed Joint Structures, *Fourth NASA/DOD Advanced Composite Technology Conference*, NASA CP-3229, 1993, pp. 181-204.

46. Walker, T.W., Ilcewicz, L.B., Polland, D.R., Bodine, J.B., and Poe, C.C., Jr., Tension Fracture of Laminates for Transport Fuselage - Part 3: Structural Configurations, *Fourth NASA/DoD Advanced Composites Technology Conference*, NASA CP-3229, 1993, pp. 243-263.
47. Smith, P.J., Bodine, J. B., Preuss, C.H., and Koch, W.J., Design, Analysis, and Fabrication of a Pressure Box Test Fixture for Tension Damage Tolerance Testing of Curved Fuselage Panels, *Third NASA Advanced Composite Technology Conference*, CP-3178, 1992, pp. 789-805.
48. Rouse, M., Ambur, D., and Wang, J., Evaluation of Damaged and Undamaged Fuselage Panel Responses Subjected to Internal Pressure and Axial Tension, Sixth NASA/DOD/ARPA Advanced Composite Technology Conference, NASA CP-3326, 1996.
49. Wang, J., Poe, C., and Ambur, D., Residual Strength Prediction of Fuselage Panel with Discrete Source Damage, Sixth NASA/DOD/ARPA Advanced Composite Technology Conference, NASA CP-3326, 1996.
50. McGowan, D., Young, R., Swanson, G., and Waters, A.: Compression Tests and Nonlinear Analyses of a Stringer- and Frame- Stiffened Graphite-Epoxy Fuselage Crown Panel, Fifth NASA/DOD/ARPA Advanced Composite Technology Conference, NASA CP-3294, 1995, pp. 321-350.
51. Ambur, D., Rouse, M., Starnes, J., and Shuart, M., Facilities for Combined Loads Testing of Aircraft Structures to Satisfy Structural Technology Development Requirements, Fifth NASA/DOD/ARPA Advanced Composite Technology Conference, NASA CP-3294, 1995, pp. 73-91.
52. Minguet, P. Fedro, M., O'Brien, T.K., Martin, R., and Ilcewicz, L.: Development of Structural Test Simulating Pressure Pillowing Effects in a Bonded Skin/Stringer/Frame Configuration, Fourth Advanced Composite Technology Conference, NASA CP-3229, 1993, pp. 863-880.
53. Minguet, P., and O'Brien, T.K., Analysis of Test Methods for Characterizing Skin/Stringer Debonding Failures in Reinforced Composite Panels, *Proceedings of the 12th ASTM Symposium on Composite Materials: Testing and Design*, Montreal, May 1994.
54. Ku, J., McShane, H., Rao, B., Lau, A., and Awerbuch, J., Effect of Manufacturing Procedures On the Quality of the Skin/Frame Composite Structures of an Aircraft Fuselage, Final Report for Drexel University subcontract to ATCAS, June 12, 1994.
55. Wang, J., Davila, C., Sleight, D., and Krishnamurthy, T., Crown Panel Stiffener-Frame Intersection Structural Integrity Analysis, Fifth NASA/DOD Advanced Composite Technology Conference, NASA CP-3294, 1995, pp. 351-368.

56. Flynn, B.W., Bodine, J.B., Dopker, B., Finn, S., Griess, K.H., Hanson, C.T., Harris, C.G., Nelson, K.M., Walker, T.H., Kennedy, T.C., and Nahan, M.F., "Advanced Technology Composite Fuselage - Repair and Damage Assessment Supporting Maintenance," NASA CR-4733, 1997.
57. Dost, E., Avery, W., Finn, S., Grande, D., Huisken, A., Ilcewicz, L., Murphy, D., Scholz, D., Coxon, B., and Wishart, R.: Impact Damage Resistance of Composite Fuselage Structure, NASA CR-4658, 1997.
58. Bodine, J., Flynn, B., Gessel, M., Griess, K., Ilcewicz, L., Swanson, G., Nahan, M., and Epperson, J.: Repair of Composite Fuselage Panels, Fifth NASA/DOD/ARPA Advanced Composite Technology Conference, NASA CP-3294, 1995, pp. 439-462.
59. Flynn, B., Griess, K., Dopker, B., Harris, C., Nelson, K., Evans, M., Epperson, J., and McGowan, D.: Repair Developments for Sandwich Fuselage Structure, Sixth NASA/DOD/ARPA Advanced Composite Technology Conference, NASA CP-3326, 1996.
60. Harris, C.E.: Assessment of Practices in Supporting Composite Structures in the Current Fleet, Fourth NASA/DoD Advanced Composites Technology Conference, NASA CP-3229, 1993, pp. 21-35.
61. Komorowski, J., Gould, R., Karpala, F., and Hageniers, O.: Inspection of Aircraft Structures Using *D* Sight, *39th International SAMPE*, 1994.
62. Reynolds, R., Karpala, F., Clarke, D., and Hageniers, O.: Theory and Applications of a Surface Inspection Technique Using Double Pass Retroreflection, *Optical Engineering*, 32 (9), Sept., 1993, pp. 2122-2129.
63. Swanson, G.D., Wishart, R.E., and Eastland, C.C.M., Compression Test Results for Stiffened Composite Fuselage Structure, *Fourth NASA/DOD Advanced Composite Technology Conference*, NASA CP-3229, 1993, pp. 125-179.
64. Cise, D.M., *Investigations Into the Nature of Moisture Ingression in Honeycomb Core Sandwich Panels*, MS Thesis, University of Iowa (under the direction of Prof. R.S. Lakes), Dec., 1995.
65. Gutowski, T., Hoult, D., Dillon, G., Neoh, E., Muter, S., Kim, E., and Tse, M., Development of a Theoretical Cost Model for Advanced Composite Fabrication, *Composites Manufacturing*, Vol. 5, No. 4, 1994, pp. 231- 239.
66. Neoh, E., Gutowski, T., Dillon, G., Framework for Estimating Fabrication Time of Advanced Composites Manufacturing Processes, 40th International SAMPE Symposium and Exhibition, Anaheim, CA, May, 1995.
67. Neoh, E. T., "Adaptive Framework for Estimating Fabrication Time of Advanced Composites Manufacturing Processes," Massachusetts Institute of Technology, PHD Dissertation, Department of Mechanical Engineering, Aug., 1995.

REPORT DOCUMENTATION PAGE			Form Approved OMB No. 0704-0188	
Public reporting burden for this collection of information is estimated to average 1 hour per response, including the time for reviewing instructions, searching existing data sources, gathering and maintaining the data needed, and completing and reviewing the collection of information. Send comments regarding this burden estimate or any other aspect of this collection of information, including suggestions for reducing this burden, to Washington Headquarters Services, Directorate for Information Operations and Reports, 1215 Jefferson Davis Highway, Suite 1204, Arlington, VA 22202-4302, and to the Office of Management and Budget, Paperwork Reduction Project (0704-0188), Washington DC 20503.				
1. AGENCY USE ONLY (Leave Blank)		2. REPORT DATE April 1997	3. REPORT TYPE AND DATES COVERED Contractor Report	
4. TITLE AND SUBTITLE Advanced Technology Composite Fuselage - Program Overview			5. FUNDING NUMBERS C NAS1-18889 C NAS1-20013 (Task 2) WU 510-02-13-01	
6. AUTHOR(S) L.B. Ilciewicz, P.J. Smith, C.T. Hanson, T.H. Walker, S.L. Metschan, G.E. Mabson, K.S. Willden, B.W. Flynn, D.B. Scholz, D.R. Pollard, H.G. Fredrikson, J.T. Olson, and B.F. Backman				
7. PERFORMING ORGANIZATION NAME(S) AND ADDRESS(ES) The Boeing Company P.O. Box 3707 Seattle, WA 98124-2207			8. PERFORMING ORGANIZATION REPORT NUMBER	
9. SPONSORING / MONITORING AGENCY NAME(S) AND ADDRESS(ES) National Aeronautics and Space Administration Langley Research Center Hampton, VA 23681-0001			10. SPONSORING / MONITORING AGENCY REPORT NUMBER NASA CR-4734	
11. SUPPLEMENTARY NOTES Langley Technical Monitor: W.T. Freeman, Jr.				
12a. DISTRIBUTION / AVAILABILITY STATEMENT RESTRICTED Publicly Available Subject Category 24			12b. DISTRIBUTION CODE	
13. ABSTRACT (Maximum 200 words) The Advanced Technology Composite Aircraft Structures (ATCAS) program has studied transport fuselage structure with a large potential reduction in the total direct operating costs for wide-body commercial transports. The baseline fuselage section was divided into four "quadrants", crown, keel, and sides, gaining the manufacturing cost advantage possible with larger panels. Key processes found to have savings potential include (1) skins laminated by automatic fiber placement, (2) braided frames using resin transfer molding, and (3) panel bond technology that minimized mechanical fastening. The cost and weight of the baseline fuselage barrel was updated to complete Phase B of the program. An assessment of the former, which included labor, material, and tooling costs, was performed with the help of design cost models. Crown, keel, and side quadrant cost distributions illustrate the importance of panel design configuration, area, and other structural details. Composite sandwich panel designs were found to have the greatest cost savings potential for most quadrants. Key technical findings are summarized as an introduction to the other contractor reports documenting Phase A and B work completed in functional areas. The current program status in resolving critical technical issues is also highlighted.				
14. SUBJECT TERMS Advanced Composite Technology Program; Transport fuselage; Overview; Cost and weight reduction; Manufacturing; Materials and processes; Structures; Damage tolerance; Maintenance; Design cost model			15. NUMBER OF PAGES 140	
			16. PRICE CODE	
17. SECURITY CLASSIFICATION OF REPORT Unclassified	18. SECURITY CLASSIFICATION OF THIS PAGE Unclassified	19. SECURITY CLASSIFICATION OF ABSTRACT Unclassified	20. LIMITATION OF ABSTRACT	