

IN-27
027 259

Creep and Rupture Strength of an Advanced CVD SiC Fiber

J.C. Goldsby
Lewis Research Center
Cleveland, Ohio

H.M. Yun
Cleveland State University
Cleveland, Ohio

James A. DiCarlo
Lewis Research Center
Cleveland, Ohio

April 1997



National Aeronautics and
Space Administration

Trade names or manufacturers' names are used in this report for identification only. This usage does not constitute an official endorsement, either expressed or implied, by the National Aeronautics and Space Administration.

Creep and Rupture of an Advanced CVD SiC Fiber

J.C. Goldsby

National Aeronautics and Space Administration
Lewis Research Center Cleveland, Ohio

H. M. Yun

Cleveland State University, Cleveland, Ohio

J. A. DiCarlo

National Aeronautics and Space Administration
Lewis Research Center Cleveland, Ohio

Abstract

In the as-produced condition the room temperature strength (~6 GPa) of Textron Specialty Materials' 50 mm CVD SiC fiber represents the highest value thus far obtained for commercially produced polycrystalline SiC fibers. To understand whether this strength can be maintained after composite processing conditions, high temperature studies were performed on the effects of time, stress, and environment on 1400 °C tensile creep strain and stress rupture on as-produced, chemically vapor deposited SiC fibers. Creep strain results were consistent, allowing an evaluation of time and stress effects. Test environment had no influence on creep strain but 1 hour annealing at 1600 °C in argon gas significantly reduced the total creep strain and increased the stress dependence. This is attributed to changes in the free carbon morphology and its distribution within the CVD SiC fiber. For the as-produced and annealed fibers, strength at 1400 °C was found to decrease from a fast fracture value of 2 GPa to a 100-hr rupture strength value of 0.8 GPa. In addition a loss of fast fracture strength from 6 GPa is attributed to thermally induced changes in the outer carbon coating and microstructure. Scatter in rupture times made a definitive analysis of environmental and annealing effects on creep strength difficult.

Introduction

Ceramic matrix composites are leading candidates for advanced materials for use under severe conditions. Potential reinforcements for these composites are chemically vapor deposited (CVD) silicon carbide (SiC) polycrystalline fibers. These fiber materials offer high thermal conductivity, high as-produced strength, high stiffness, and has the potential to retain these properties for long times to 1400 °C. The recently developed developmental 50 mm CVD SiC fiber (SCS-X) from Textron Specialty Materials has the highest room temperature strength (6 GPa) of any polycrystalline SiC fiber currently available. In addition, a carbon-rich microstructure suggests rupture and creep resistance of these fibers will be better than Textron's standard SCS-6 fiber [1]. In an earlier study [2] showed through bend stress relaxation tests, performed under constant strain, that the 50 mm fiber possessed greater relaxation resistance than the SCS-6 fiber. These authors also showed that annealing the fiber to temperatures above 1400 °C further improved the bend stress relaxation behavior. Based upon the suggested reinforcement potential of the 50 mm CVD SiC fiber the purpose of this investigation was to obtain a preliminary evaluation of time, stress, environment, and annealing influences on the strength retention of this fiber under conditions of interest for ceramic composites.

Experimental Procedure

Figures 1 and 2 illustrate experimental set-ups for air and vacuum creep testing. Aluminum cold grips attached the fiber to the test frame and strain measuring instrumentation, well outside the hot

zone of the furnace. Creep and rupture testing were performed at 1400 °C under dead weight loading conditions. The load was applied at room temperature, then the fiber was subjected to a rapid temperature increase (100 °C/min) to the test temperature. The duration of these tests was from 0.001 up to 147 hr, however tests which exceeded 100 hr without fiber failure were interrupted. The applied stresses were between 300 and 3000 MPa. The upper limit was selected based upon fast fracture strength measurements made on these fibers at room temperature after 100 hr exposure in argon gas from 1400 to 1600 °C [1]. Annealing treatments for this study was performed in the test furnace at 1600 °C in argon gas for 1 hour prior to the creep strain measurements at 1400 °C.

Two variations of the 50 mm CVD SiC fibers (SCS-X) developed by Textron Specialty Materials were studied in this investigation. The spooled fibers were designated A and B, with spool B containing more carbon in its microstructure than spool A fiber. Figure 3 illustrates schematically the microstructure of the 50 mm fiber in comparison to the SCS-6 fiber [2]. The cross section of the fiber reveals that microstructurally the SiC sheath of the 50 mm fiber is similar to the inner SiC morphology of the SCS-6 fiber.

Results and Discussion

Figure 4 shows the data of [1] for room temperature strength of the spool B fiber after being annealed in air for 2 min and in argon from 1 to 100 hr. From Figure 4, it can be seen that the as-produced strength of 6 GPa decreases with increasing temperature of exposure, and appears to level off above 1400 °C to about 2 GPa. Reference 1 attribute this major strength degradation primarily to loss of the crack blunting capability of the carbon-rich coating on the SiC sheath. This allows creation of critical surface flaws which lead to fiber failure. The data in Figure 4 also shows that, during long-time creep testing in argon at 1400 °C, fiber strength degrades due to thermal aging, however the exact aging mechanism is not clear. On the other hand, thermal aging mechanisms in air remove the protective carbon coating during the early stages of creep, where continual oxidation may then damage the exposed SiC surface which eventually lead to strength degradation. For the purpose of this study, Figure 4 suggests that the initial applied creep-rupture stress should be no greater than 2 GPa in order to obtain 100 hr creep test data. Figure 5 illustrates as-produced fiber creep behavior at 1400 °C as function of spool and environment. For a stress of 890 MPa, creep strains did not exceed 1.5% in 100 hr. Under these test conditions, creep was mostly transient in character with a power law-time dependence ($t^{1/3}$). Slight differences in creep strain (0.2%) exist between vacuum and air data for spool A. For the same environmental conditions (vacuum), spool B Fiber creeps more than spool A Fiber.

The effects of annealing (1600 °C for one hour in an argon atmosphere with no applied load) on tensile creep strain, with an applied stress of 1380 MPa, are illustrated in Figure 6. In general the annealed fibers show a large reduction in the total creep strain as compared with the as-produced spool A fiber. The transient creep stage decreased and a steady state regime became evident. Another important annealing effect was a change in the stress dependent creep strain (Figure 7). Stress dependence on 100 hr creep strain for the as-produced and annealed fibers changed from 2 to 4 for these respective cases. Within the data scatter, the stress exponent for as-produced fibers is independent of spool or environment. Creep behavior of Figures 4 and 5 suggest a two term power law expression for the total creep strain up to 100 hr at 1400 °C as,

$$\epsilon = K_1 \sigma^{n_1} t^{p_1} + K_2 \sigma^{n_2} t^{p_2} \quad (1)$$

where K is an arbitrary constant and the applied stress σ possess the exponents $n_1 = 2$ and $n_2 = 4$ while the time t is raised to the $p_1 = 1/3$ and $p_2 = 1$ powers for the respective terms. Hence two

dominant flow mechanisms are active, giving rise to transient and steady state creep behavior. The first term on the right hand side of Eq. 1 gives rise to transient behavior in the as-produced fiber (mechanism 1) and the second term to reduced transient and steady state creep behavior in the annealed fiber (mechanism 2). Previous TEM studies [1] suggest that mechanism 1 is probably controlled by the migration and redistribution of free carbon in the grain boundaries, which results in a lack of pinning agents necessary to prevent grain boundary sliding. On the other hand, the high stress dependence (indicative of dislocation controlled creep) for the annealed fibers suggests that a relatively carbon-free SiC sheath may allow an increase in dislocation mobility causing mechanism 2. Figure 7 indicates mechanism 2 may also be active for long-times and relatively high applied stress in the as-produced fibers. That is a noted reduction in rupture strength with time follows nearly the same time dependence as the reduction in strength after annealing with no applied stress (c.f. Figure 4). Figure 8 summarizes rupture results in terms of rupture time versus applied stress. While a wide scatter in rupture times is evident, a general trend toward reduced strength with increasing time is evident. For all tested fibers, average rupture strength after 100 hr at 1400 °C is approximately 800 MPa which is significantly higher than the 300 MPa observed for other polycrystalline SiC fibers produced by polymer pyrolysis [3].

Conclusions

While the carbon-rich coating has a significant influence on the high as-produced room temperature strength of the developmental 50 mm CVD fiber, even with the coating effectively removed, this fiber is still the strongest currently available small diameter SiC fiber up to 1400 °C for 100 hr in inert and air environments. The fiber's creep and rupture performances are apparently related to the slightly carbon-rich microstructure which inhibits grain growth and grain boundary sliding. Annealing the fiber imparts excellent creep resistance, possibly by stabilizing the free carbon in the fiber microstructure. Sources of the wide scatter in rupture strength have yet to be determined.

References

1. Bhatt, R.T., Garg, A. and Hull, D.R., "Microstructural and Strength Stability of a Developmental CVD SiC Fibers," TM-107008, prepared for the proceedings of the 96th Annual Meeting and Exposition of the American Ceramic Society, Indianapolis, Indiana, April 24-28, 1994 (1995).
2. Morscher, G.N., Lewinsohn, C.A., Bakis, C.E., Tressler, R.E. and Wagner, T., "Comparison of Bend Stress Relaxation and Tensile Creep of CVD SiC Fibers," Journal of the American Ceramic Society, volume 78, number 12 pp. 3244-3252, (1995).
3. Hurst, J.B., Yun, H.M. and Gorician, D. "Creep and Stress Rupture Behavior of Sintered SiC Fibers," Presented at the 18th Annual Conference and Exposition on Composites, Materials and Structures, (Restricted Sessions), Cocoa Beach, Florida, January 9-14, 1994.
4. Ning, X. J. and Pirouz, P., "The Microstructure of SCS-6 SiC Fiber" Journal of Materials Research, volume 6, number 10, p. 2234-46 (1991).
5. Lewinshohn, C.A., Giannuzzi, L.A. Bakis, C.E. and Tressler, R.E. "An Investigation of the Creep Behavior and Microstructural Changes During Creep of CVD Silicon Carbide Monofilaments" HITEMP Review 1993, volume III, NASA CP-19117, pp. 86-1 to 86-11 (available from NASA CASI), 1993.

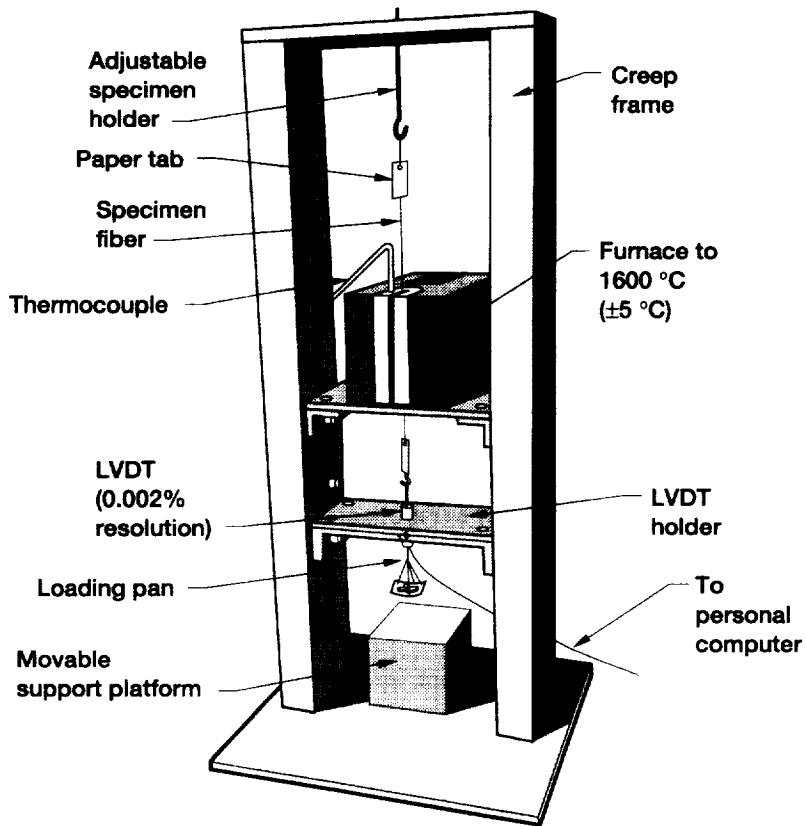

Figure 1.—Apparatus used to determine tensile creep in air using dead loading system.

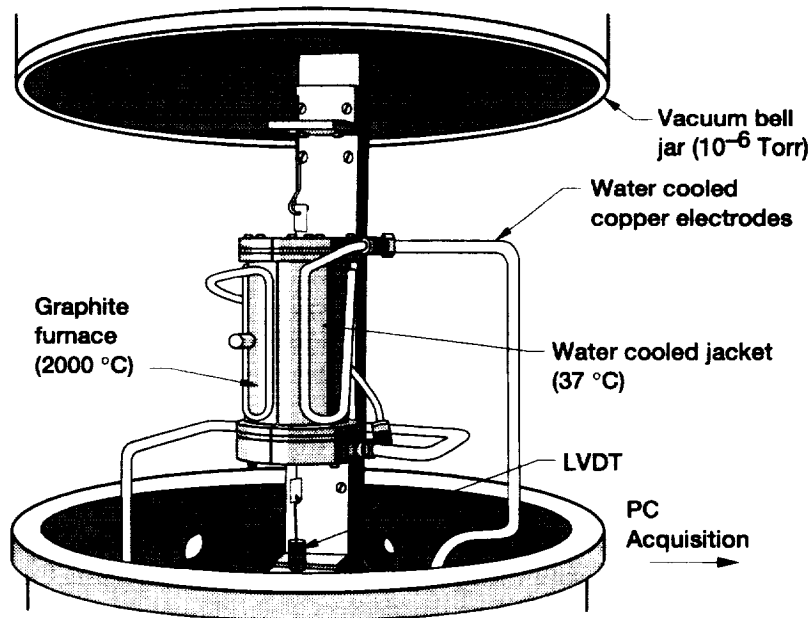

Figure 2.—Apparatus used to determine tensile creep testing in vacuum using dead loading system.

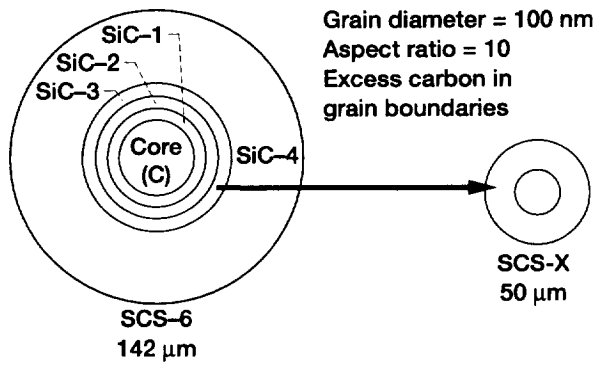

Figure 3.—Schematic layout of the CVD SiC SCS series fibers [2,4].

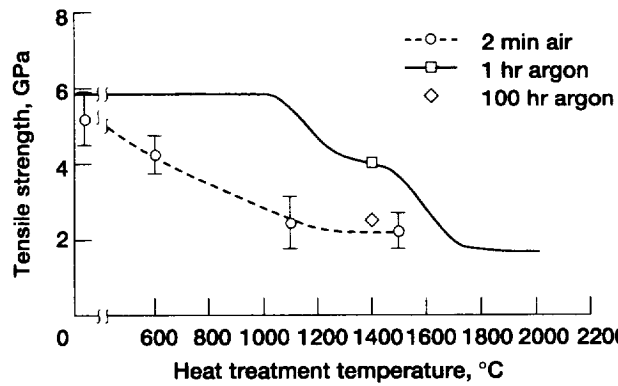

Figure 4.—Effects of temperature on the room temperature strength of heat treated 50 μm SCS-X fibers [1].

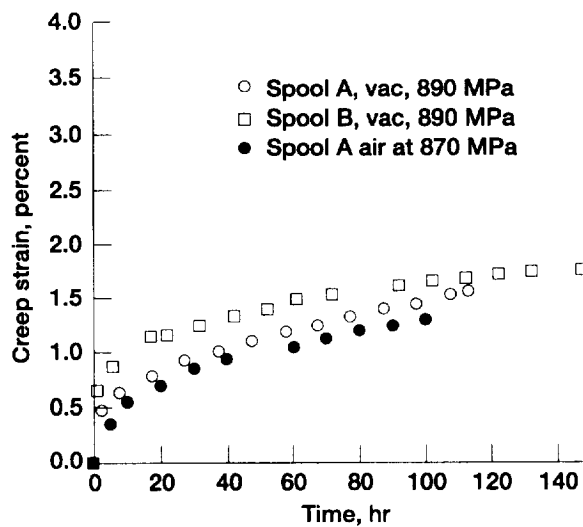

Figure 5.—Creep behavior of 50 μm SCS-X fibers at 1400 °C.

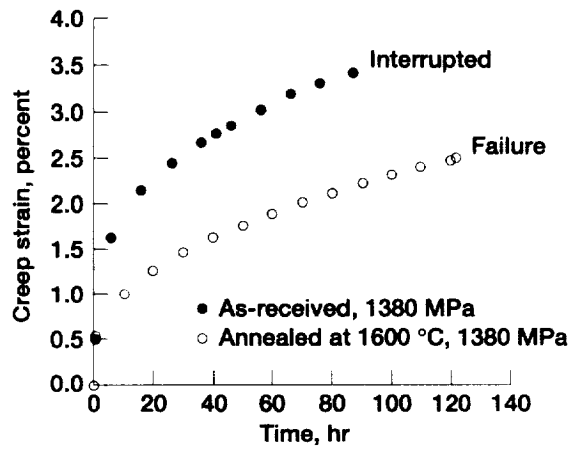

Figure 6.—Effects of annealing on creep behavior of 50 μm SCS-X fibers at 1400 $^{\circ}\text{C}$.

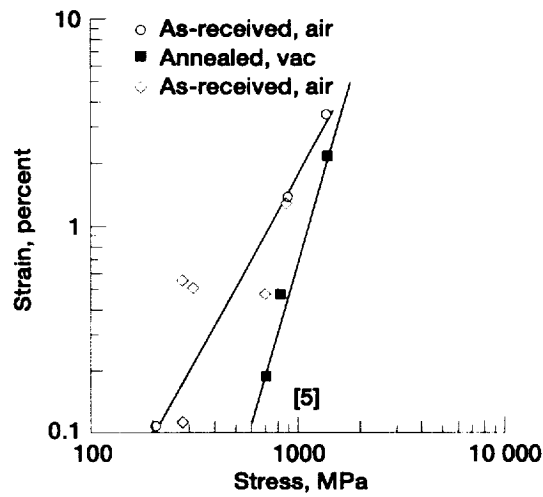

Figure 7.—Effects of stress on 100 hr creep strain of 50 μm CVD SCS-X fibers.

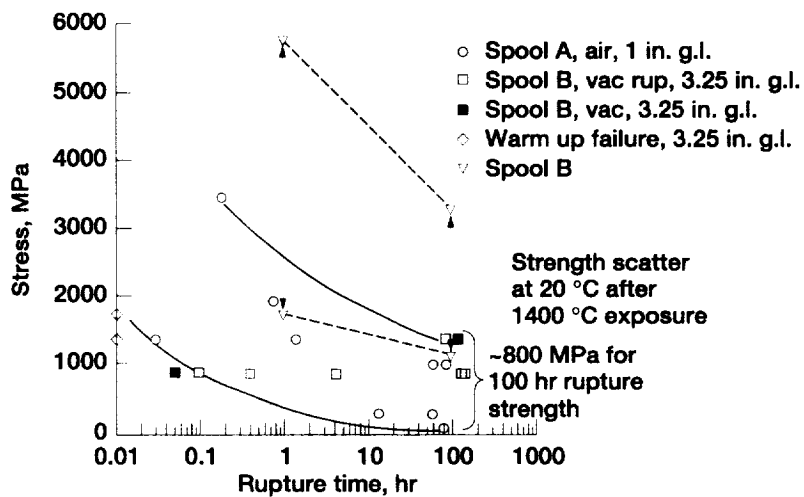

Figure 8.—Stress rupture behavior at 1400 $^{\circ}\text{C}$ of 50 μm CVD SCS-X fibers.

REPORT DOCUMENTATION PAGE

Form Approved
OMB No. 0704-0188

Public reporting burden for this collection of information is estimated to average 1 hour per response, including the time for reviewing instructions, searching existing data sources, gathering and maintaining the data needed, and completing and reviewing the collection of information. Send comments regarding this burden estimate or any other aspect of this collection of information, including suggestions for reducing this burden, to Washington Headquarters Services, Directorate for Information Operations and Reports, 1215 Jefferson Davis Highway, Suite 1204, Arlington, VA 22202-4302, and to the Office of Management and Budget, Paperwork Reduction Project (0704-0188), Washington, DC 20503.

1. AGENCY USE ONLY (Leave blank)		2. REPORT DATE April 1997	3. REPORT TYPE AND DATES COVERED Technical Memorandum	
4. TITLE AND SUBTITLE Creep and Rupture Strength of an Advanced CVD SiC Fiber			5. FUNDING NUMBERS WU-505-63-12	
6. AUTHOR(S) J.C. Goldsby, H.M. Yun, and J.A. DiCarlo				
7. PERFORMING ORGANIZATION NAME(S) AND ADDRESS(ES) National Aeronautics and Space Administration Lewis Research Center Cleveland, Ohio 44135-3191			8. PERFORMING ORGANIZATION REPORT NUMBER E-10536	
9. SPONSORING/MONITORING AGENCY NAME(S) AND ADDRESS(ES) National Aeronautics and Space Administration Washington, DC 20546-0001			10. SPONSORING/MONITORING AGENCY REPORT NUMBER NASA TM-107368	
11. SUPPLEMENTARY NOTES J.C. Goldsby and J.A. DiCarlo, NASA Lewis Research Center; H.M. Yun, Cleveland State University, Cleveland, Ohio 44115 and NASA Resident Research Associate at Lewis Research Center. Responsible person, J.C. Goldsby, organization code 5130, (216) 433-8250.				
12a. DISTRIBUTION/AVAILABILITY STATEMENT Unclassified - Unlimited Subject Categories 27 and 39 This publication is available from the NASA Center for AeroSpace Information, (301) 621-0390.			12b. DISTRIBUTION CODE	
13. ABSTRACT (Maximum 200 words) In the as-produced condition the room temperature strength (~6 GPa) of Textron Specialty Materials' 50 μm CVD SiC fiber represents the highest value thus far obtained for commercially produced polycrystalline SiC fibers. To understand whether this strength can be maintained after composite processing conditions, high temperature studies were performed on the effects of time, stress, and environment on 1400°C tensile creep strain and stress rupture on as-produced, chemically vapor deposited SiC fibers. Creep strain results were consistent, allowing an evaluation of time and stress effects. Test environment had no influence on creep strain but 1 hour annealing at 1600°C in argon gas significantly reduced the total creep strain and increased the stress dependence. This is attributed to changes in the free carbon morphology and its distribution within the CVD SiC fiber. For the as-produced and annealed fibers, strength at 1400°C was found to decrease from a fast fracture value of 2 GPa to a 100-hour rupture strength value of 0.8 GPa. In addition a loss of fast fracture strength from 6 GPa is attributed to thermally induced changes in the outer carbon coating and microstructure. Scatter in rupture times made a definitive analysis of environmental and annealing effects on creep strength difficult.				
14. SUBJECT TERMS Creep; SiC; Fiber; Ceramic; Stress rupture; Composite; CMC			15. NUMBER OF PAGES 9	
			16. PRICE CODE A02	
17. SECURITY CLASSIFICATION OF REPORT Unclassified	18. SECURITY CLASSIFICATION OF THIS PAGE Unclassified	19. SECURITY CLASSIFICATION OF ABSTRACT Unclassified	20. LIMITATION OF ABSTRACT	