

THERMODYNAMIC STUDIES OF HIGH TEMPERATURE MATERIALS VIA KNUDSEN CELL MASS SPECTROMETRY

36-25

NATHAN S. JACOBSON and Michael P. Brady*
NASA Lewis Research Center
Cleveland, OH 44135

The Knudsen Cell technique is a classic technique from high temperature chemistry for studying condensed phase/vapor equilibria. It is based on a small enclosure, usually about 1 cm in diameter by 1 cm high, with an orifice of well-defined geometry. This forms a molecular beam which is analyzed with mass spectrometry. There are many applications to both fundamental and applied problems with high temperature materials. Specific measurements include vapor pressures and vapor compositions above solids, activities of alloy components, and fundamental gas/solid reactions (ref. 1).

The basic system is shown in Fig. 2. Our system can accommodate a wide range of samples, temperatures, and attachments, such as gas inlets. It is one of only about ten such systems world-wide.

In order to obtain precise data, there are a number of critical experimental issues. These include selection of an inert Knudsen cell material, uniform temperature throughout the cell and accurate temperature measurement. A common problem in all types of mass spectrometry is to identify the gases ('parent molecules') which form a particular peak in the mass spectrometer. This is done via the mass-to-charge ratio, isotopic abundances, and various other techniques (ref. 1). It is also critical to separate the background composition from a given peak. This is accomplished with the shutter shown in Fig. 2. Finally the measured ion current must be converted to a vapor pressure and/or thermodynamic activity. A standard of known vapor pressure, such as gold or silver, is used to calibrate the system. In our twin cell configuration, this calibration is done *in-situ* as an integral part of each experiment.

Two examples will be discussed. First consider the vaporization of a cylindrical alumina combustor in a stream of high temperature combustion gases. This problem is illustrated in Figs. 6-8. The problem is to determine how hot the combustor can be before volatility becomes a limiting issue. In general, vapor pressures greater than $\sim 10^{-6}$ bar lead to recession rates greater than 10 mils/10,000 hrs, which are not acceptable for long term operation (ref. 2). To do this calculation, Knudsen cell measurements on Al-O(g) species together with estimates on Al-O-H(g) species are needed (refs. 3 and 4). These are put into a free energy minimization program together with the combustion gas composition (ref. 5). The results are shown in Fig. 8. At temperatures greater than 2170 K, volatility becomes a limiting issue.

* Formerly NRC Associate at NASA LeRC, Currently at Oak Ridge National Laboratory

The second example is thermodynamic activity measurements in the Ti-Al and Ti-Al-X systems. These are important for many applications including: prediction of oxidation properties (i.e. will TiO or Al₂O₃ be the stable oxide?) (ref. 6), prediction of alloy/fiber reactions (ref. 7), and phase diagram assessments. For these measurements, we use a unique twin cell flange for comparing the alloy to the standard *in-situ*. This is illustrated in Figs. 10 and 11. Measurements were made of aluminum activity and where possible titanium activity. The Ti-Al phase diagram is shown in Fig. 12 and sample measurements about the γ -TiAl phase field are shown in Fig. 13. These have been shown consistent with measurements of other investigators. A critical issue in oxidation is understanding the effect of alloying elements. For example it is known chromium promotes oxide formation. Is this by increasing Al activity and decreasing Ti activity? Measurements are currently underway to determine this. Al activity measurements are shown in Fig. 15.

A brief description of high temperature Knudsen cell mass spectrometry has been given. It has been used many years on many systems. However it continues to provide useful applied and fundamental data on high temperature materials. NASA LeRC has a unique facility for this technique. Two specific examples are discussed: vaporization of Al₂O₃ and thermodynamic activity measurements for Ti-Al-X alloys.

References:

1. Hilpert, K.: "Chemistry of Inorganic Vapors" in Structure and Bonding 73, Springer-Verlag, Berlin, 1990.
2. Jacobson, N. S.: High Temperature Durability Considerations for the HSCT Combustor", NASA TP 3162, January 1992.
3. Paule, R. C.: Mass Spectrometric Studies of Al₂O₃ Vaporization Processes. High Temp. Sci., vol. 8, no. 3, 1976, pp. 257-266.
4. Chase, M. W., Jr., et. al., eds.: JANAF Thermochemical Tables, 3rd Edition, American Chemical and American Physical Society, New York, NY, 1985.
5. Eriksson, G. A. and Hack, K.: ChemSage—A Computer Program for the Calculation of Complex Chemical Equilibria, Met. Trans. vol. 21B, 1991, pp. 1013-1023.
6. Brady, M. P., et. al.: The Oxidation and Protection of Gamma Titanium Aluminides, JOM, vol. 48, no. 11, 1996, pp. 46-50.
7. Misra, A. K.: Reaction of Ti and Ti-Al Alloys with Alumina, Met. Trans. vol. 22A, 1991, pp. 715-721.

Knudsen Cell Technique

- Classic technique from High Temperature Chemistry to study solid/vapor equilibria.
- Small cell, well defined orifice—form molecular beam to analyze vapor, generally with mass spectrometry.
- Many applications to high temperature materials.

Fig. 1

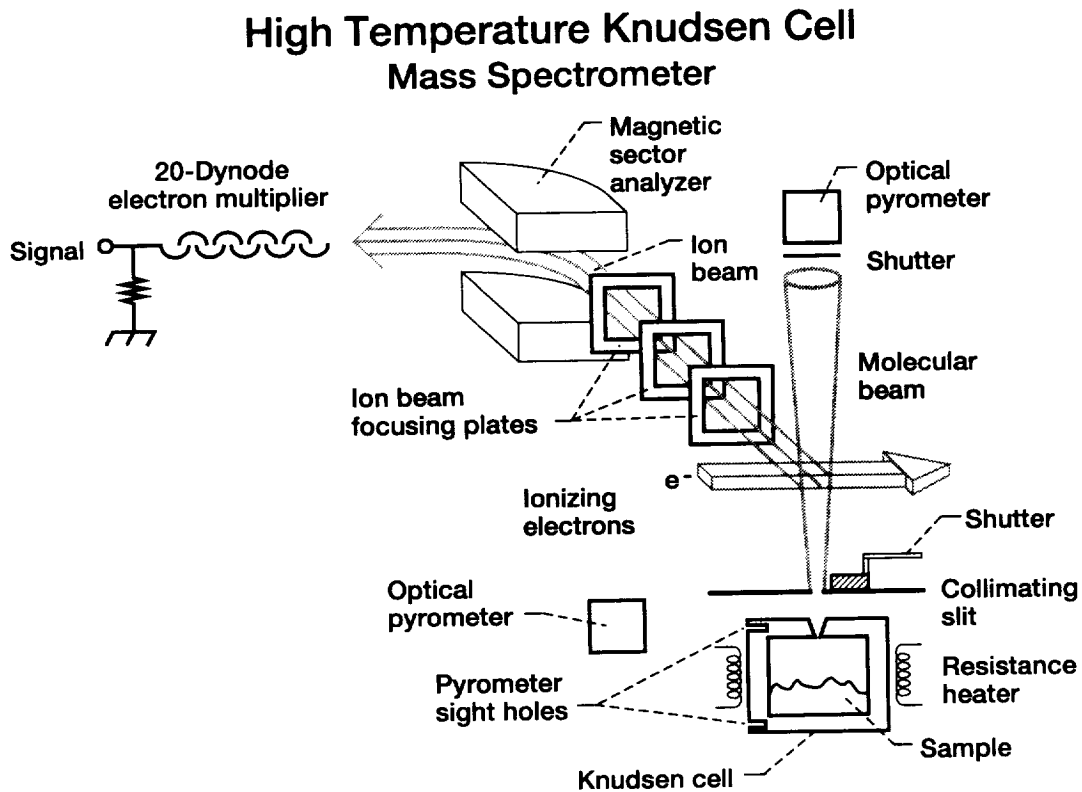

Fig. 2

CD-91-52433

Knudsen Cell Measurements

- **Basic and applied problems:**
 - Vapor pressures above solids
 - Activities of alloy components
 - Gas/solid reactions
- **Much of the tabulated thermodynamic data is from this technique.**
- **Only about 10 laboratories worldwide have this capability.**

Fig. 3

Critical Experimental Issues

- **Knudsen Cell:**
 - Inert container material.
 - Uniform temperature.
 - Accurate temperature measurement.
 - Use melting points of pure materials to calibrate.
- **Identify the gases which form a particular peak in mass spectrometer.**
- **Separate background from signal.**
- **Relate intensity to vapor pressure.**

Fig. 4

Types of Measurements

- Identify vapor species—e.g., $\text{Al}_2\text{O}(\text{g})$ over $\text{Al}_2\text{O}_3(\text{s})$.
- Determine absolute vapor pressures.
- Heats of vaporization
 - Second law: Slope of $\ln P$ vs. $1/T = \Delta H/R$
- Compare vapor pressure of an alloy component to that of a pure metal.
 - $a(\text{A}) = P(\text{A})/P^\circ(\text{A})$
- Leak in external gas—look at gas/solid reaction.

Fig. 5

Example 1: Vaporization of Alumina

- Actual problem: cylindrical alumina combustor with a stream of hot combustor gases (N_2 , O_2 , CO_2 , H_2O)
- How hot can we make the alumina before volatility becomes an issue?
- Long term operation < 10 mils/10,000 hr — $< 10^{-6}$ bar

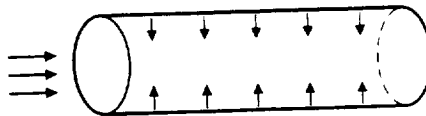

Fig. 6

Equilibrium Vaporization of Al_2O_3 into a Vacuum

- R. C. Paule, H. Temp. Sci. 8, 257 (1976) + many other Knudsen Cell Studies.
- Main reactions:
 - $\text{Al}_2\text{O}_3 = 2 \text{Al}(\text{g}) + 3 \text{O}(\text{g})$
 - $\text{Al}_2\text{O}_3 = 2 \text{AlO}(\text{g}) + \text{O}(\text{g})$
 - $2 \text{O}(\text{g}) = \text{O}_2(\text{g})$
- Suppressed by oxygen.

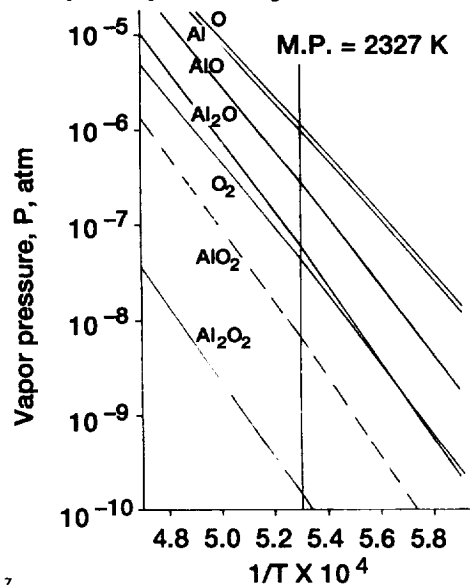

Fig. 7

Equilibrium Vaporization of Al_2O_3 into a Combustion Atmosphere

- Use thermodynamic data from Knudsen Cell investigations and estimates for Al-O and Al-O-H
- Computer code which considers all vaporization reactions:

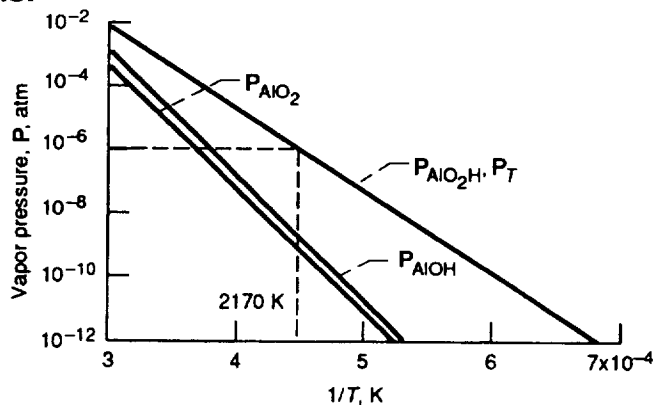

Fig. 8

Example 2: Thermodynamic Activity Measurements in Ti-Al and Ti-Al-X

- Activity: “Escaping tendency”—ratio of vapor pressure of metal in alloy to pure metal—tells how tightly bound metal is in alloy.
- Uses:
 - Predict oxidation characteristics.
 - Predict alloy/fiber reactions (Misra, Met. Trans. 22A, 715 (1991)).
 - $3\text{Ti} + \text{Al}_2\text{O}_3 = 3\text{TiO} + 2\text{Al}$
 - Phase diagram assessments.

Fig. 9

Double Cell Technique

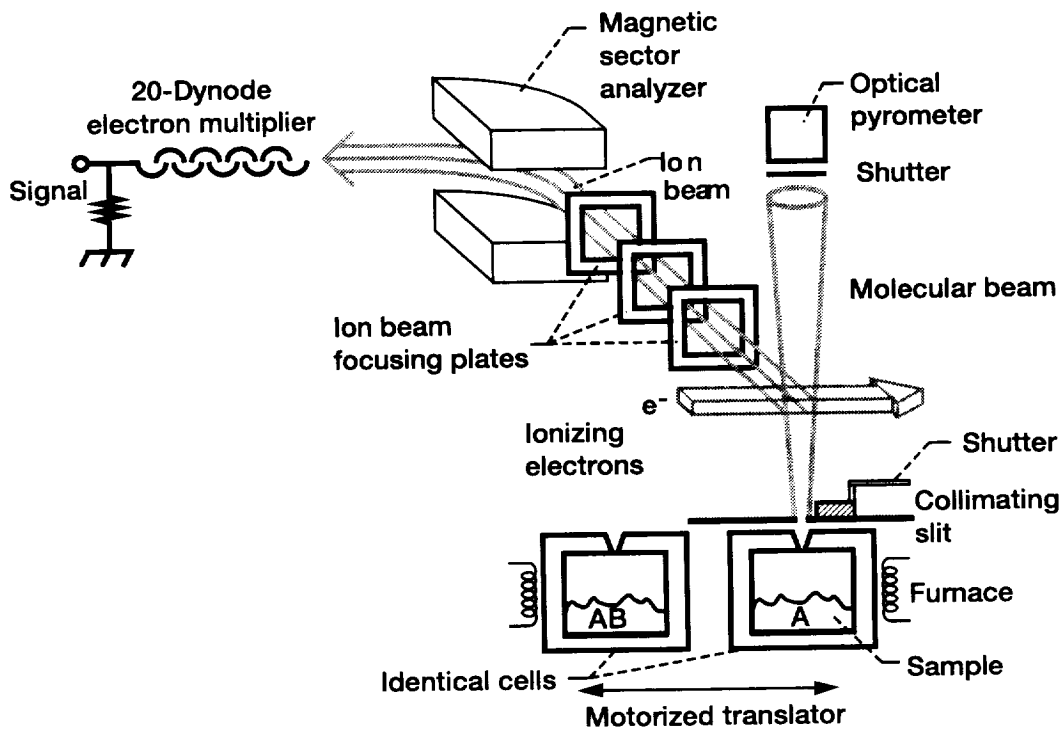

Fig. 10

CD-93-85925

Knudsen Cell Flange

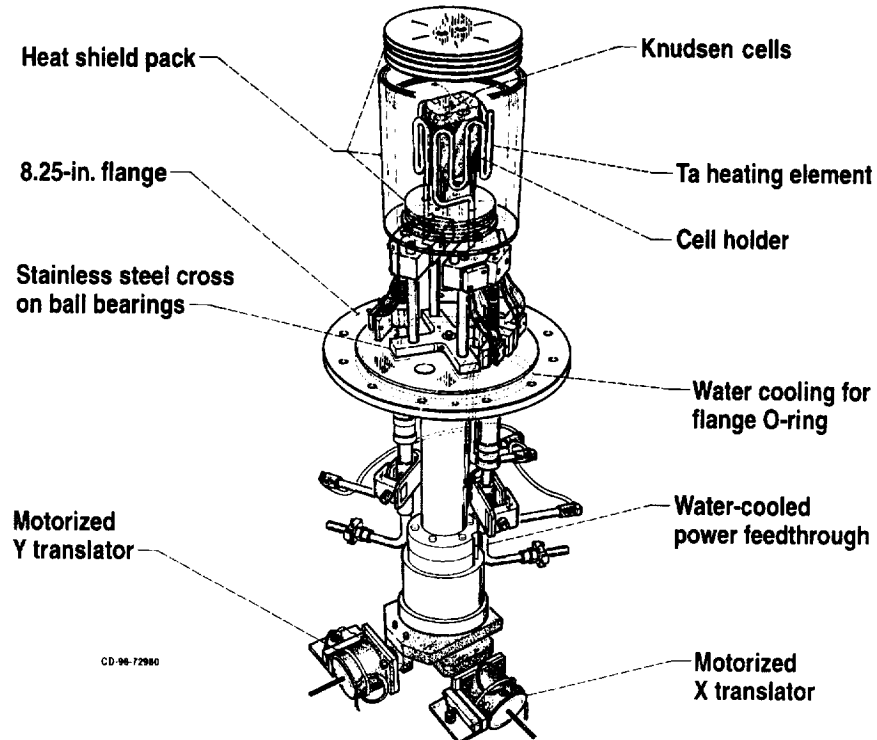
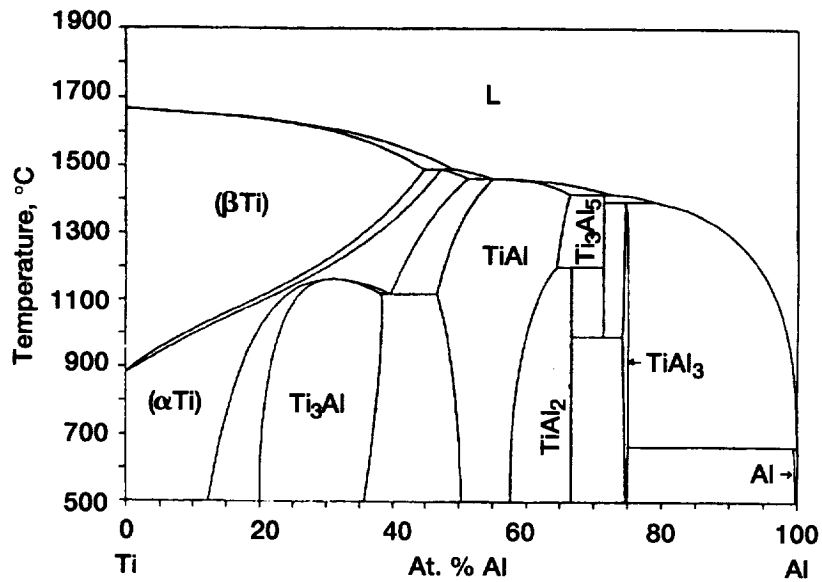

Fig. 11

Ti-Al Phase Diagram



Kattner, Lin, and Chang, *Met. Trans.* 23A, 2081 (1992).
Focus on γ -TiAl and adjacent two phase regions.

Fig. 12

Al Activity Data Near γ -Ti-Al

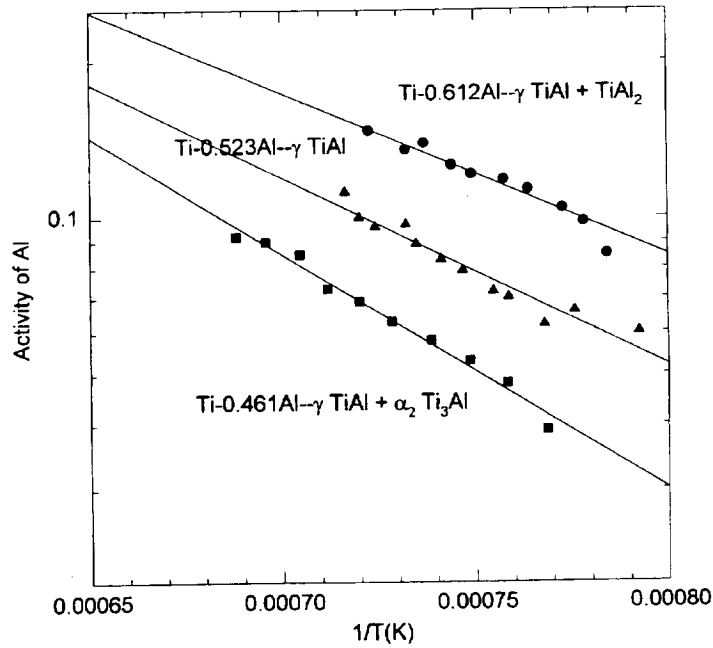

Fig. 13

Ti-Al-X Studies

- Alloying additions (esp. Cr) promote Al_2O_3 formation and limit TiO formation.
- Is this by increasing $a(\text{Al})$ and decreasing $a(\text{Ti})$?
- Examine
 - Ti-48Al-2Cr Ti-48Al-13Cr
 - Ti-48Al-2Nb Ti-48Al-13Nb
 - Ti-48Al-2Nb-2Cr
- Work in progress—currently looking at $a(\text{Ti})$

Fig. 14

Activity of Al in Ti-Al-X Alloys

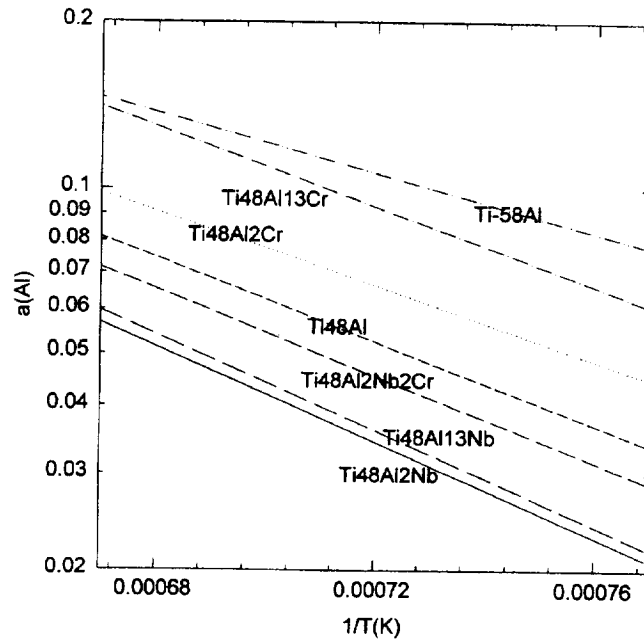

Fig. 15

Summary

- **Classic experimental technique for studying solid/vapor equilibria.**
 - Unique facility at NASA LeRC.
- **Experimental Technique**
 - Inert cell.
 - Precise temperature measurement.
 - Convert ion intensities to partial pressures.
- **Many, many applications. Two examples:**
 - Vaporization of Al_2O_3 .
 - Thermodynamics of Ti-Al-X alloys.

Fig. 16