

NASA/TM-97-206224



Performance of an Electro-Hydrostatic Actuator on the F-18 Systems Research Aircraft

*Robert Navarro
Dryden Flight Research Center
Edwards, California*

October 1997

The NASA STI Program Office . . . in Profile

Since its founding, NASA has been dedicated to the advancement of aeronautics and space science. The NASA Scientific and Technical Information (STI) Program Office plays a key part in helping NASA maintain this important role.

The NASA STI Program Office is operated by Langley Research Center, the lead center for NASA's scientific and technical information. The NASA STI Program Office provides access to the NASA STI Database, the largest collection of aeronautical and space science STI in the world. The Program Office is also NASA's institutional mechanism for disseminating the results of its research and development activities. These results are published by NASA in the NASA STI Report Series, which includes the following report types:

- **TECHNICAL PUBLICATION.** Reports of completed research or a major significant phase of research that present the results of NASA programs and include extensive data or theoretical analysis. Includes compilations of significant scientific and technical data and information deemed to be of continuing reference value. NASA's counterpart of peer-reviewed formal professional papers but has less stringent limitations on manuscript length and extent of graphic presentations.
- **TECHNICAL MEMORANDUM.** Scientific and technical findings that are preliminary or of specialized interest, e.g., quick release reports, working papers, and bibliographies that contain minimal annotation. Does not contain extensive analysis.
- **CONTRACTOR REPORT.** Scientific and technical findings by NASA-sponsored contractors and grantees.
- **CONFERENCE PUBLICATION.** Collected papers from scientific and technical conferences, symposia, seminars, or other meetings sponsored or cosponsored by NASA.
- **SPECIAL PUBLICATION.** Scientific, technical, or historical information from NASA programs, projects, and mission, often concerned with subjects having substantial public interest.
- **TECHNICAL TRANSLATION.** English-language translations of foreign scientific and technical material pertinent to NASA's mission.

Specialized services that complement the STI Program Office's diverse offerings include creating custom thesauri, building customized databases, organizing and publishing research results . . . even providing videos.

For more information about the NASA STI Program Office, see the following:

- Access the NASA STI Program Home Page at <http://www.sti.nasa.gov>
- E-mail your question via the Internet to help@sti.nasa.gov
- Fax your question to the NASA Access Help Desk at (301) 621-0134
- Telephone the NASA Access Help Desk at (301) 621-0390
- Write to:
NASA Access Help Desk
NASA Center for AeroSpace Information
800 Elkridge Landing Road
Linthicum Heights, MD 21090-2934

NASA/TM-97-206224



Performance of an Electro-Hydrostatic Actuator on the F-18 Systems Research Aircraft

*Robert Navarro
Dryden Flight Research Center
Edwards, California*

National Aeronautics and
Space Administration

Dryden Flight Research Center
Edwards, California 93523-0273

October 1997

NOTICE

Use of trade names or names of manufacturers in this document does not constitute an official endorsement of such products or manufacturers, either expressed or implied, by the National Aeronautics and Space Administration.

Available from:

NASA Center for AeroSpace Information
800 Elkridge Landing Road
Linthicum Heights, MD 21090-2934
Price Code: A16

National Technical Information Service
5285 Port Royal Road
Springfield, VA 22161
Price Code: A16

PERFORMANCE OF AN ELECTRO-HYDROSTATIC ACTUATOR ON THE F-18 SYSTEMS RESEARCH AIRCRAFT

Robert Navarro

NASA Dryden Flight Research Center
P.O. Box 273
Edwards, California 93523-0273
USA

ABSTRACT

An electro-hydrostatic actuator was evaluated at NASA Dryden Flight Research Center, Edwards, California. The primary goal of testing this actuator system was the flight demonstration of power-by-wire technology on a primary flight control surface. The electro-hydrostatic actuator uses an electric motor to drive a hydraulic pump and relies on local hydraulics for force transmission. This actuator replaced the F-18 standard left aileron actuator on the F-18 Systems Research Aircraft and was evaluated throughout the Systems Research Aircraft flight envelope. As of July 24, 1997 the electro-hydrostatic actuator had accumulated 23.5 hours of flight time. This paper presents the electro-hydrostatic actuator system configuration and component description, ground and flight test plans, ground and flight test results, and lessons learned. This actuator performs as well as the standard actuator and has more load capability than required by aileron actuator specifications of McDonnell-Douglas Aircraft, St. Louis, Missouri. The electro-hydrostatic actuator system passed all of its ground tests with the exception of one power-off test during unloaded dynamic cycling.

NOMENCLATURE

A/C aircraft
ADC analog to digital converter
ATP acceptance test procedure
BIT built-in-test
°C degree Celsius
CPU computer processing unit

DAC digital to analog converter
DCI Dynamic Controls, Incorporated,
Dayton, Ohio
EHA electro-hydrostatic actuator
°F degree Fahrenheit
FCC flight control computer
FCS flight control system
FMET failure mode and effects test
FWT flightworthiness test procedure
g gravity
H/W hardware
Hz Hertz
IBIT initiated built-in-test
Ibox interface box
lbf pound-force
LMCS Lockheed-Martin Control Systems,
Johnson City, New York
LVDT linear variable differential transformer
MCT Mos Control Thyristor
MDA McDonnell-Douglas Aircraft, St. Louis,
Missouri
MDC McDonnell-Douglas Corporation, Long
Beach, California
MIL-STD- Response Multiplex Data Bus
1553 (Military Standard)
ms milliseconds
mV millivolts
NASA National Aeronautics and Space
Administration
PCME power control and monitoring

	electronics
PCU	power conversion unit
PBW	power-by-wire
ram	shaft of the actuator
SOV	shutoff valve (solenoid operated valve)
SRA	Systems Research Aircraft
V	voltage
WPAFB	Wright-Patterson Air Force Base

INTRODUCTION

The F-18 Systems Research Aircraft (SRA) [1], (fig. 1), at the National Aeronautics and Space Administration (NASA) Dryden Flight Research Center (DFRC) is a dual-purpose test bed benefiting both commercial and military developments. A primary goal is to identify and flight test new technologies on the SRA that will be beneficial to subsonic, supersonic, hypersonic, or space applications. One of these technologies is the electro-hydrostatic actuator (EHA) system, provided by Wright-Patterson Air Force Base (WPAFB), Dayton, Ohio. Using the EHA eliminates the central hydraulic system and reduces complexity, maintenance and support personnel. The two interface boxes (Ibox) and the power conversion unit (PCU) used for these tests were provided by Dynamic Controls, Incorporated (DCI), Dayton, Ohio. Lockheed-Martin Control Systems (LMCS), Johnson City, New York, integrated the actuator, motor, pump, and electronics. Dowty Aerospace, Duarte, California; Vickers, Jackson, Mississippi; and Electromech, Wichita, Kansas, provided the actuator, pump, and electric motor.

Testing the EHA system demonstrated in flight power-by-wire (PBW) technology on a primary flight control surface. For this test the EHA (fig. 2) replaced the standard F-18 left aileron actuator on the SRA. The flight test program consisted of several maneuvers throughout the SRA flight envelope. This report presents EHA test results during the maneuvers and compares them to the standard aileron actuator. Lessons learned during ground testing are also presented.

SYSTEM DESCRIPTION

The SRA was retrofitted with a larger left wing hinge half to accommodate the larger size of the EHA (fig. 3). Figure 4 shows the EHA integrated into the left wing of the SRA.

The EHA system consists of the following elements:

- The electro-hydrostatic actuator (EHA)
- Two independent interface boxes (Ibox)
- One power control and monitoring electronics (PCME) unit
- One power conversion unit (PCU)
- The pilot control panel located in the F-18 SRA cockpit

Figure 5 shows the interface of the EHA components and the two flight control computers (FCC's). The FCC's (FCC ch 1 and FCC ch 4) generate servo-current position commands which are fed to the Iboxes, one Ibox for each FCC channel. The Iboxes receive the servocurrent position commands from the FCC's, generate commands to the PCME and generate a simulated feedback response to the FCC's. The simulated feedback is used for loop closure and to fool the FCC's into thinking that there is a standard actuator on board. The PCME receives the command signals generated by the Iboxes, then compares these signals to verify that they are within a set limit and averages them into a single command signal for the EHA. The EHA feeds status and health information back to the PCME to be used for fault detection. The PCU provides the high power necessary to the EHA through the PCME. Figure 6 shows the location of the EHA system components in the SRA.

Two EHA systems sets, PCME and EHA, were delivered to DFRC as a primary and a backup. The sets were not interchangeable and they were classified as set 1 and set 2. To meet performance requirements, each EHA motor resolver had a specific calibration constant, which was coded into the software of the PCME. Therefore, the EHA and PCME were paired together by the resolver calibration constant. Thus, replacing one of the units would require a software modification to the PCME for the calibration constant of the resolver.

The Electro-Hydrostatic Actuator

The EHA utilizes a single positive displacement bidirectional bent-axis pump driven by a single three-phase, permanent magnet motor. The motor direction determines ram extension or retraction. The 41.5 lb actuator is designed to require no active cooling. The EHA contains a hydraulic fluid accumulator which is packaged together with fluid components, and a bypass shutoff valve (SOV). The hydraulic integrated manifold contains two back-to-back check valves, two cross-port pressure relief valves and the solenoid operated shutoff valve with an internal damping orifice. The two back-to-back check valves allow the reservoir to replenish fluid in the balanced actuator cylinder. Cross-port pressure relief valves are used to protect the actuator, mounting structure, and aileron surface from overpressure and overstress. The SOV disengages the actuator ram from the motor and pump assembly, reverts cycling the fluid through an orifice from one side to the other of the balanced actuator ram, to provide the trail-damped mode. The EHA also uses a linear variable differential transformer (LVDT) and a resolver for position feedback. It has a temperature transducer and a pressure transducer for status and health information used by the PCME. The LVDT measures ram position, the temperature transducer measures motor winding temperature, the pressure transducer measures reservoir pressure, and the resolver measures motor rotor position and velocity.

The Power Control and Monitoring Electronics

The electronics required for controlling the power and position commands to the EHA and the monitoring of the actuator responses are located in the PCME unit (fig. 7). The PCME is equipped with an 115 V ac cooling fan and weighs approximately 20 lb. The electronics monitoring provides continuous fault monitoring and transfers the actuator to the trail-damped mode when any failure is detected. The PCME communicates with the SRA FCC's through the two Iboxes. The inputs to the PCME provide commands for actuator mode and position. These actuator command signals are translated by the PCME hardware and software into motor current commands through appropriate control laws which enable the actuator to be driven to its desired position. The PCME is responsible for actuator position, motor velocity, and current (acceleration) loop closures. In

addition, the PCME software provides BIT capabilities to test the PCME computer hardware, sensors, servoelectronics and actuator mechanics.

The PCME receives the high power ± 135 V dc from the PCU and translates it to current commands for the EHA through the Mos Controlled Thyristors (MCT). Regenerative energy from the EHA is stored in capacitors. Any excess regenerative energy is dissipated through an external resistor bank.

The Interface Boxes

The Iboxes (fig. 8) provide the interface between the F-18 FCCs and the EHA system. The Iboxes provide the two FCC channels (FCC ch1 and FCC ch4) with all the required loop closures. Two Iboxes are used, one for each FCC channel. The Iboxes receive the servocurrent position commands from the FCC's, generate the commands to be sent to the PCME, and generate the simulated feedback responses to the FCC's. The Iboxes also provide monitoring of the research actuator through the system and allow research and performance data to be monitored through a MIL-STD-1553 Response Multiplex Data Bus (1553 data bus) [2].

The PCME reports health status of the EHA system to the Iboxes. Once the Iboxes receive a failure, the simulated position feedback to the FCC's recognize open position feedback as a failure. Once the FCC's recognize the failure, it de-energizes the SOV output signal which causes the Iboxes to command the EHA system into a trail-damped mode. The PCME also de-energizes the SOV.

The Iboxes are designed to self-monitor internal functions. Because there is no cross-channel communications between the Iboxes, discrepancies between the two channel position commands received by the FCC's cannot be detected by the Iboxes. Therefore, each Ibox splits the servocurrent position commands into two redundant paths to generate position command signals for the PCME. The two command signals are compared and their differences calculated. If the difference is not within a set limit a failure is declared and the position feedbacks are opened to the FCC's, transferring the EHA system to the trail-damped mode. The Ibox self-monitoring system includes failures of power supply, software and central processing unit (CPU).

The Power Conversion Unit

The PCU (fig. 9) provides the ± 135 V dc, which powers the EHA system. The PCU takes the 115 V ac, 400 Hz, three-phase F-18 aircraft power and converts it to ± 135 V dc, which is delivered to the PCME. The PCME then sends the high power through the MCT's to the motor windings. The PCU is fused with two 35-amp fuses to protect the aircraft electrical systems and EHA system.

The Pilot Control Panel

The pilot control panel contains control switches for various experiments integrated into the SRA. Four control push-button switches and a toggle switch are allocated for the EHA system as follows (fig. 10).

- *The Ibox mode* switch commands the EHA system to be in Normal or Test mode, Normal mode puts the system in normal operation mode and Test mode is selected when performing an aircraft flight control system (FCS) BIT.
- *The IBIT button* commands the EHA system initiated BIT. IBIT is used by the PCME to verify the failure logic used to monitor correct operation of the EHA prior to aircraft takeoff (weight-on-wheels is needed to invoke IBIT). After a successful completion of IBIT the button is lit to indicate a passed condition for the test.
- *The reset button* is used to reset the EHA system after IBIT or a failure. The system only resets with weight-on-wheels (aircraft on ground).
- *The PCME BIT enable switch*, in the off position, prevents one Ibox from sending an IBIT command to the PCME which prevents initiating an IBIT on the ground. It is used as a precaution to prevent an IBIT in flight.
- *The left aileron disable switch* allows the pilot to actively de-energize the SOV valve and transfer the EHA into a trail-damped mode.

GROUND TEST PLAN AND DESCRIPTION

The ground test plan includes the acceptance test procedure (ATP) and flightworthiness test procedure (FWT) conducted by LMCS. These procedures were derived from the EHA statement of work produced by WPAFB, which referenced the MDA aileron actuator specification. The validation test procedures conducted by DFRC were developed in response to

the requirements set up by the statement of work, LMCS ATP, and FWT.

Testing by LMCS included electrical, mechanical, and thermal testing necessary to qualify the EHA and PCME in the F-18 environment. The EHA portion of the testing also included pressure stresses. In addition to the ATP and FWT, the PCME contained a preflight and continuous built-in-test (BIT) to verify the system operation.

Flightworthiness Test Plan

The flightworthiness test (FWT) plan covered the environmental portion for the EHA system. This test is a comprehensive one and ensures design requirements are met for the EHA and PCME. The FWT is comprised of the following tests:

- Altitude and rate of change
- Temperature (continuous, intermittent and shock)
- Voltage power transients (28 V dc and 270 V dc)
- Vibration (resonance, sinusoidal and random)
- Impact shock
- Threshold and Linearity
- Endurance
- Limit load
- Output force
- Ultimate load
- Insulation resistance
- Nondestructive inspection

Validation test

The validation test objectives for the EHA were met by fully integrating the system with the F-18 Ironbird. The F-18 Ironbird has hydraulically operated horizontal stabilators, rudders and ailerons. Other F-18 surfaces are simulated using analog actuator models. The Ironbird also includes a test bench to perform open-loop and stand-alone testing of the FCC's. The validation test objectives consisted of a functional test, continuous operation test, frequency and rate limit test, and the failure mode and effects test (FMET).

Functional test—The functional test confirmed the following operations of the EHA system:

- Perform a successful EHA reset
- Perform EHA BIT successfully multiple times and consecutively
- Perform full-up and full-down commands successfully
- Perform aircraft RIG mode operation successfully
- Perform EPAD BIT in all flap settings successfully
- Perform aircraft FCS IBIT and Test Group 10 BIT successfully
- Perform hardware simulation and data recording functional checks

Continuous test—The continuous test ensured that the EHA system operated under normal conditions for an extended period of time. The test consisted of operating the EHA for five (5) 1-hour segments at 0.3 Hz sinusoidal and are listed as follows:

- Amplitude of 50 percent of full stroke
- Aileron biased at 6° up
- Aileron biased at 0° deflection
- Flap switch set at half-flap setting (30° down)
- Flap switch set at Up/Auto setting (0°)

Amplitude for some of the tests listed were adjusted to clear the stops of the actuator.

Frequency response and rate limit test—The frequency response test was conducted to obtain open-loop and closed-loop response of the left (EHA) and right (standard actuator) ailerons. The requirement is that the difference between the left and right ailerons should not exceed 0.5 dB in gain and 5° in phase. The open- and closed-loop frequency response test was performed using the small amplitude log sweep at 5 percent of full stroke command over a frequency range from 0.1 Hz to 15 Hz. The rate limit test was performed with the EHA system using a square wave input sweep with an amplitude of 95 percent of full scale with a constant frequency of 0.1 Hz.

Failure modes and effects test—The purpose of FMET is to obtain failure mode responses and effects

of failures on the EHA system. The FMET test consisted of actuator signal management failures, cockpit signal management failures and power failures during a simulated test condition. The actuator signal management failures consisted of interrupting signals upstream and downstream of Iboxes, and verifying that the EHA fails to a trail-damped mode during a simulated flight condition. The cockpit signal management failures included inhibiting individual discrete signals during a simulated flight condition at different flap settings. The power failures consisted of interrupting power to components during a simulated flight condition.

Actuator signal management upstream of Iboxes.

Failures for the actuator signal management upstream of Iboxes consisted of interrupting the following signals at a simulated condition of Mach 0.6, at an altitude of 25,000 ft during an aileron reversal, and verifying EHA fails to a trail-damped mode on channels 1 and 4:

- Left aileron command
- Left Aileron LVDT excitation
- Left Aileron SOV
- Left Aileron pressure switch
- Left Aileron ram position
- Biasing aileron command

Actuator signal management downstream of Iboxes.

For the actuator signal management downstream of Iboxes, failures consisted of interrupting the following signals at a simulated flight condition of Mach 0.6, at an altitude of 25,000 ft during an aileron reversal, while verifying EHA fails to a trail-damped mode on channels 1 and 4:

- Position command
- Biasing position command
- Position command PCME fault tolerance detection
- Shutoff of actuator
- Position command fail
- Fail-safe mode

Cockpit Signal Management. The cockpit signal management failures include inhibiting individual discrete signals at a simulated level flight of 160 kn

and an altitude of 25,000 ft. The requirements are to (1) verify EHA fails to a trail-damped mode when commanded by the disable switch, (2) verify the EHA system does not reset through the reset switch, (3) verify the EHA system does not perform a BIT through the EHA IBIT switch, and (4) verify IBIT is not performed without weight-on-wheels discretes.

Component Power Failures. The power failures tests consisted of interrupting power to the following components at a simulated flight condition of Mach 0.6 and an altitude of 25,000 ft during an aileron reversal while verifying EHA fails to a trail-damped mode: (1) Iboxes, (2) PCME, (3) High power to PCME through PCU, and (4) High power to actuator (all motor windings).

FLIGHT TEST DESCRIPTION

A test matrix was developed after the ground test demonstrated that the EHA meets standard F-18 aileron actuator requirements. The test points were devised using the F-18 simulation to map the F-18 envelope with q-bar and aileron hinge moment as the primary variables. The flight test matrix was broken into the following three phases, functional checks, envelope mapping and mission profiles and were flown in that order. All three flight test phases performed the following maneuvers; doublets, windup turns, aileron reversals, straight and level turns, lateral frequency sweeps, and aerobatic maneuvers. A gradual hinge-moment buildup approach was used in testing the EHA. Each phase of flight test was completed by conducting the maneuvers with medium-rate half-stick inputs and evaluating the performance of the EHA. A visual inspection of the EHA was performed between the first three flights. Upon completing the first three phases of flights, evaluating the data, and verifying by visual inspection that no anomalies were found on the EHA; the phases of flights were repeated conducting the maneuvers with abrupt full-stick inputs. The EHA was required to complete 25 hours of flight time. The functional checks phase was flown at a safe altitude of 25,000 ft and mach 0.4. The envelope mapping phase of flights included altitudes of 10,000 ft, 20,000 ft, 35,000 ft and 40,000 ft with mach numbers ranging from 0.54 to 1.6. The mission profiles phase included the following aerobatic maneuvers; Wingover, Barrel Roll, Aileron Roll, 4-Point Roll, 8-Point Roll, Split S, Loop, Immelman, Cloverleaf, Cuban 8 and the Chinese Immelman.

TEST RESULTS

Ground and flight test results are described next. Tables and figures are used to more clearly delineate results.

Ground Test Results

The EHA successfully passed the ATP, FWT, and validation tests (functional, continuous and frequency). Table 1 through 4 illustrate requirements and test results. Figure 11 shows that the EHA and standard open-loop frequency are within MDA aileron small amplitude specification limits. Figure 12 shows that the EHA tracks closely to the standard actuator in the open-loop frequency response.

The FMET tests and results are presented in tables 5 through 8. The EHA system successfully passed all FMET tests with the exception of one of the power failures (table 8). The power failures were devised to be tested during an in-flight (simulation) dynamic maneuver (aileron reversal). During the 28 V dc power failure test of the PCME, the EHA system went to a trail-damped mode as designed, but the power transient caused damage to the MCT's. Results from troubleshooting indicated that the inverter drive using the MCT's was sensitive to loss of 28 V dc power transients during dynamic cycling of the aileron (loaded and unloaded). The same test was conducted previously with a static actuator (uncommanded) and it did not damage any MCT's in the PCME. The cycling rate threshold that caused the failure was not determined. No correction was incorporated into the hardware and the MCT failure was accepted as a low probability and severity risk.

Flight Test Results

The EHA has successfully flown on the SRA since January 1997, and as of July 24, 1997 it has accumulated 23.5 hours of flight time. Table 9 summarizes the first five flights, which include the in-flight failures and their causes.

The first EHA (set 1) flight took place on January 16, 1996, on flight 564. Approximately 9 min into the flight, the EHA system went into a trail-damped mode as designed. The SRA landed safely without extra effort from the pilot. Set 1 was qualified by similarity because it had completed and passed the ATP and validation testing. Set 1 environmental testing was waived since the second EHA system

(set 2) had completed and passed environmental testing. During troubleshooting of the in-flight failure, it was found that the PCME would not detect an open motor phase during normal operation mode. An open motor phase is detected by the preflight BIT. Open motor phase failure detection was incorporated in the PCME software. In addition, load tests were performed to quantify the effect of open phases to the dynamic stiffness of the actuation system. It was determined that the EHA would have sufficient dynamic stiffness with one open phase.

The second EHA system (set 2) was first flown on November 4, 1996, on flight 583 and successfully completed aircraft functional flight checks. The second flight was flown on November 12, 1996, on flight 584 and included an aircraft engine cycling test. The engine cycling test requires an engine shutdown and restart in flight. During the first engine shutdown (right engine) the EHA system went into a trail-damped mode. The cause of the EHA in-flight shutdown was a power surge caused by switching to the left generator, because the right engine is coupled with the right generator. During this generator transition (less than 50 ms) the power surge is propagated through the 28 V dc control power to the PCME. The MCT's in the PCME were damaged because of the power surge during engine power down. A power surge filtering circuit was installed on the 28 V dc power to the PCME to reduce power transients to the PCME during engine shutdowns.

While set 2 was being repaired, set 1 (qualified by similarity) was installed in the aircraft. The cause of the flight 564 failure was suspected to be the loss of 28 V dc power in the power supply internal to the PCME. All components of the power supply were tested and no anomalies were found. A vibration problem was speculated to be the cause, so set 1 was vibrated to the worst-case axis. This vibration test did not reproduce the failure. Set 1 was reflown on January 10, 1997, on flight 585 and shortly after takeoff the EHA system went into a trail-damped mode. The failures of set 1 for the two flights, 564 and 585, were correlated to altitude. Both in-flight failures occurred at an altitude of slightly above 11,000 ft. The failure was reproduced in an altitude chamber and the cause of the shutdown was determined to be arcing. The leads in the power supply would arc to a circuit board located above the power supply at higher altitudes. The arcing was

stopped by adding a layer of capton tape between the leads and the circuit board.

Figure 13 and 14 show the in-flight failures of flight 564 and 585, respectively. Trace 1 shows how the EHA position feedback departs from the average position command at the time of failure. The average position command is designed to move to a positive 1.9 volts, hardover down, once the EHA system has failed. This hardover down command during a failure was incorporated to minimize the differential between the ailerons in case the EHA system inadvertently came back online, particularly when the aircraft is close to the ground. The EHA is in a trail-damped mode once a failure has been detected. Trace 2, with the standard actuator aileron position inverted and trim removed, is plotted against the EHA aileron position. As illustrated, the EHA position departs from standard actuator position at the time of failure as it fails to a trail-damped mode. Trace 3 illustrates SRA altitude at the time of failure.

Set 2 was integrated into the SRA again and began flying on January 16, 1997 with medium rate inputs. As of July 24, 1997, the EHA system, set 2, had completed 24 flights [3] totaling 23.5 hours of flight time and has flown flawlessly. Table 10 illustrates the maximum and minimum temperatures the PCME and EHA experienced and the maximum hinge moment measured.

Figure 15 through 18 show typical test maneuvers. Trace 1 illustrates tracking of the EHA position feedback with the average position command. The timelag between command and feedback is approximately 30 ms and is associated with data sampling. In trace 2 the standard actuator aileron position is inverted and trim is removed, and then plotted against the EHA aileron position. Here the EHA performs as well as the standard actuator. Trace 3 shows the EHA hinge moment, a negative hinge moment puts the actuator in tension and a positive hinge moment puts the actuator in compression. Figures 19 and 20 illustrate the test points where the EHA actuator stalled. Figure 21 shows a test point where the standard actuator stalled and the EHA did not.

CONCLUDING REMARKS

The ground test procedures were conducted to verify that the electro-hydrostatic actuator and the power

control and monitoring electronics components met design requirements and were qualified as flightworthy for the F-18 aircraft.

The ground testing phase pointed out that the Mos Control Thyristors which are used for power control in the power control and monitoring electronics unit, are sensitive to a loss of 28 V dc power transients during dynamic cycling of the actuator (loaded and unloaded). Mos Control Thyristor's are a new technology and the manufacturer did not have sufficient test data to characterize the performance of them.

The flight test plan was devised to test and evaluate the electro-hydrostatic actuator performance throughout the F-18 Systems Research Aircraft flight envelope. The electro-hydrostatic actuator position feedback tracked well with the position command and the system has flown flawlessly since the addition of the 28 V dc power surge filter to the power control and monitoring electronics unit. The electro-hydrostatic actuator did stall twice, as expected, at high hinge moment maneuvers where the external load was greater than the maximum output load. The electro-hydrostatic actuator appears to have more load capability than required by actuator specifications, and has performed as well as the standard actuator throughout the envelope of the F-18 Systems Research Aircraft. General performance of the electro-hydrostatic actuator is good. The fail-safe design and trail-damped mode worked well after three in-flight failures were encountered. Pilots indicate that flying with an electro-hydrostatic actuator on the F-18 Systems Research Aircraft feels the same as if a standard actuator were on board.

LESSONS LEARNED

The following lessons were learned throughout the EHA system program.

Controller to actuator interchangeability: In order to meet position accuracy requirements, the system is calibrated as a controller and actuator set. Two sets were provided to DFRC for testing, a primary set and a backup set. Thus, the units are not interchangeable. Replacing any one of the units requires a software modification to the calibration constant of the motor resolver. Software management is an issue, especially developing acceptable tests to prove system

functionality, confirm successful software loading, and minimum acceptance criteria. It would have been beneficial to the program to have interchangeable units.

Open phase detection: The PCME detected an open phase during the pre-flight BIT on the ground but did not detect an open phase to the actuator during normal operation. A design modification was required to provide continuous detection on an open motor phase. In addition, load tests were performed to quantify the effect of open phases to the dynamic stiffness of the actuation system. It was determined that the EHA would have sufficient dynamic stiffness with one open phase. It is recommended that input and output power paths of all components be tested.

Avionics power transients: Transients in avionics 28 V dc power may result in damage of the MCT's. There were two contributing factors in the analysis of this failure. First, the avionics 28 Vdc power and the 270 V dc actuator control power were completely isolated, which resulted in a hot 270 V dc bus during the avionics 28 V dc power failure tests. Second, the MCT's, which uses avionics power, did not ensure a fail-safe position of switching cells with loss of the 28 V dc power gate drive. As a result, the cells could short the 270 V dc buses and damage controller hardware (MCT's). A power surge filtering circuit was incorporated to handle the control power of the MCT as backup devices to handle temporary power spikes or surges. Our experience with the MCT indicated that they are sensitive to power surges and that they require constant non-interruptible control power. The PCME was designed with the understanding that the 28 V dc was on a non-interruptible (battery backed-up) bus. The 28 Vdc bus in the aircraft is backed up with a battery, but the switching time to the battery or good generator (of less than 50 ms) was not pointed out in the design requirements.

Flight qualified by similarity: Two in-flight failures were experienced because the PCME set 1 was qualified by similarity. All tests were completed on set 1 with the exception of the environmental test. In addition to necessary tests, when qualifying components by similarity it is recommended to include environmental tests that reveal workmanship

variations or provide a thorough detailed component specification set of documents and inspection processes, so non-conforming parts or processes will be evident.

REFERENCES

[1] Sitz, Joel R., *F-18 Systems Research Aircraft Facility*, NASA TM-4433, Dec. 1992.

[2] *Aircraft Internal Time Division Command/Response Multiplex Data Bus*, MIL-STD-1553 (DOD), Sept. 8, 1986.

[3] Systems Research Aircraft, NASA F/A-18 # 845, Flight Report, Flights 583-590, FR-97-01 and Flights 591-600, FR-97-02, 1997.

[4] *Aircraft Electric Power Characteristics*, MIL-STD-704(DOD), May 1, 1991.

Table 1. Electro-hydrostatic actuator acceptance test procedure results.

Parameter	Units	Requirement	PCME and actuator results
Actuator sensor BIT		actuator shutdown at sensors shorted/grounded	passed
Position command match	mv	ch 1 = ch 2 = 0 ± 50 ch 1 cmd = 0	passed
Position command mismatch	V	ch 4 cmd = ± 2.1 & ch 4 cmd = ± 1.9	passed
Bus voltage too low (270 V)	V	V _{bus} = 190 ± 10	passed
Demand BIT		pass BIT	passed
Hot/cold temp test of PCME at -40	°C	Perform BIT and normal operation for 2 min	passed
Hot/cold temp test of PCME at 71	°C		passed
Output stall force	lbf	13107 ± 500	13300
	sec	10 minimum	> 30 minimum
Steady load	lbf	5000 ± 500	5100
	min	20 minimum	> 20 minimum
Ram output stroke	in. (mechanical)	± 2.25	± 2.25
	in. (electrical)	± 2.19	± 2.19
No load ram velocity	in./sec	6.7 minimum	7.7 minimum
Load vs rate			
load	lbf	6329	6329
rate	in./sec	4.88 minimum	6.0 minimum
Frequency response			
±0.5 percent command	Hz/dB/deg.	7/-7.25/92 maximum	7/-3.272/66
±5.0 percent command	Hz/dB/deg.	7/-7.25/92 maximum	7/-3.27/65
Hysteresis	percent of full stroke	0.1	0.080
Threshold	percent of full stroke	0.05	0.0375
Linearity	percent of full stroke	± 0.5	± 0.1875
Dynamic stiffness	lbf/in.	270,000 minimum	282,000

Table 2. Flightworthiness test results.*

Parameter	Units	Requirement
Altitude	ft	70,000
Rate of change	ft/min	40,000
Temperature		
Continuous	°F	-40 to 160
Intermittent	°F	180 10 min
Shock	°F	-40 to 160
Input power variations		
28 V dc transients	V	MIL-STD-704[4]
28 V dc steady and ripple test	Hz	MIL-STD-704[4]
270 V dc transient	V	MIL-STD-704[4]
Vibration (each axis)		
Resonant survey	Hz	per MDC A3376 5 to 2000
Dwell at resonance	Hz	44.8 & 49.8
Sine Cycling	Hz	5 to 50 to 5
Random	Hz	50 to 2000
Shock (each axis)		
half-sine		
g	g	20-z, 15 x and y, EHA
time	msec	35-z, 15 x and y, PCME 11
Threshold	in.	first motion not to exceed 0.002 in. command
Linearity	percent of full stroke	±0.5
Endurance	cycles	500,000
Limit load		
25° up	lbf	12,093 (compression)
0° neutral	lbf	15,800 (tension)
45° down	lbf	13,106.67 (tension)
Output force		
Compression	lbf	12,093 for 10 sec
Tension	lbf	13,106.67 for 10 sec
Ultimate load		
25° up	lbf	18,140 (compression)
0° neutral	lbf	23,700 (tension)
45° down	lbf	19,660 (tension)

*PCME and EHA, passed.

Table 3: Validation functional test results.*

Parameter	Requirement
EPAD-reset	Multiple times
EPAD BIT (Up/Auto)	Multiple times
Commands	
Full up, deg	25
Full down, deg	42
A/C Rig Mode	No failures
EHA BIT	
Half flaps	No failures
Full flaps	No failures
A/C FCS IBIT	No failures
A/C test group 10 BIT	No failures

*PCME and EHA, passed.

Table 4. Validation continuous test results.*

Parameter	Requirement
0.3 Hz sinusoidal at	
Amplitude	50 percent of full stroke (- stack)
Aileron biased	6° up
Aileron Biased	0°
Half-Flap	~30° down
Up/Auto	~0°

*PCME and EHA, passed.

Table 5: Validation FMET results (failure upstream of Iboxes).*

Parameter	Requirement
Interrupt command	
channel 1	Open
channel 4	Open
Interrupt LVDT exc.	
channel 1	Open
channel 4	Open
Interrupt SOV	
channel 1	Open
channel 4	Open
Interrupt pressure switch	
channel 1	Open
channel 4	Open
Interrupt ram position	
channel 1	Open
channel 4	Open
Bias command	
channel 1	± 8 percent of command
channel 4	± 8 percent of command

* PCME and EHA, passed.

Table 6: Validation FMET results (failure downstream of Iboxes).*

Parameter	Requirement
Interrupt command	
channel 1	Open
channel 4	Open
Interrupt PCME fault tolerance detection	
channel 1	Open
channel 4	Open
Interrupt SOV	
channel 1	Open
channel 4	Open
Interrupt command fail	
channel 1	Open
channel 4	Open
Interrupt fail safe mode	
channel 1	Open
channel 4	Open
Bias command	
channel 1	±8 percent of command
channel 4	±8 percent of command

*PCME and EHA, passed.

Table 7: FMET validation cockpit signals failures.*

Parameter	Requirement
Inhibit discrete signals of disable switch	
Inhibit 1	Open
Inhibit 2	Open
Inhibit 1 & 2	Open
Inhibit discrete signals of reset switch	
Inhibit 1	Open
Inhibit 2	Open
Inhibit discrete signals of IBIT switch	
	Inhibit 1 Open
	Inhibit 2 Open

* PCME and EHA, passed.

Table 8: Validation FMET Power failures.

Parameter	Requirement	PCME and actuator results
Interrupt Power		
Ibox 1	Remove 28 V dc	Passed
Ibox 4	Remove 28 V dc	Passed
Interrupt Power PCME		
	Remove 28 V dc	Passed (static EHA) Failed (cycling EHA)
Interrupt Power PCU		
	Remove ± 135 V dc	Passed
Interrupt Power EHA windings		
	Remove ± 135 V dc	Passed

Table 9: Flight test summary.

Date	Flight number	EHA/PCME hardware, set	Failure
1-16-96	564	1	Power supply arcs above 11,000 ft causing MCT damage in PCME.
11-4-96	583	2	None
11-12-96	584	2	Power transient during in-flight engine shutdown caused MCT damage in the PCME
1-10-97	585	1	Power supply arcs above 11,000 ft causing MCT damage in PCME. Same as the in-flight failure in flight 564.
1-16-97	586	2	(No Failures have been encountered to date since this flight.) None.

Table 10: Flight results.

Parameter	Result	Flight Condition
Warmest Temperature		
EHA	35 °C	Mach 0.42, Altitude 25,000 ft
PCME	44 °C	Mach 0.7, Altitude 25,000 ft
Coldest Temperature		
EHA	1.25 °C	Prior to takeoff
PCME	-1.77 °C	Mach 0.6, Altitude 25,000 ft
Highest Hinge Moment	57,300 in-lbf	Mach 1.6, Altitude 35,000 ft, q-bar 890 lbf/ft ²



EC93 42065-06

Figure 1. Systems Research Aircraft (SRA).

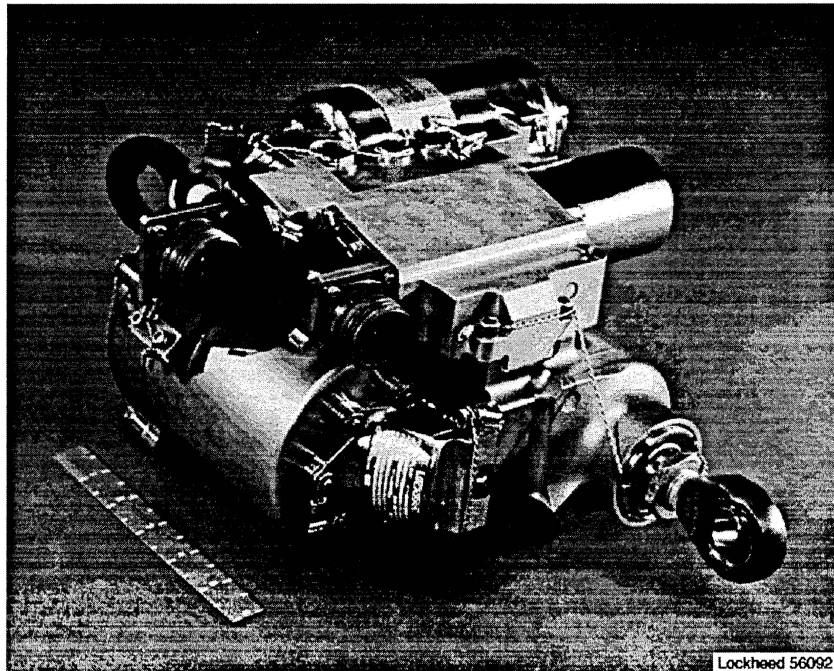

Source: Lockheed Martin Control Systems, Johnson City, New York

Figure 2. Electro-hydrostatic actuator (EHA).

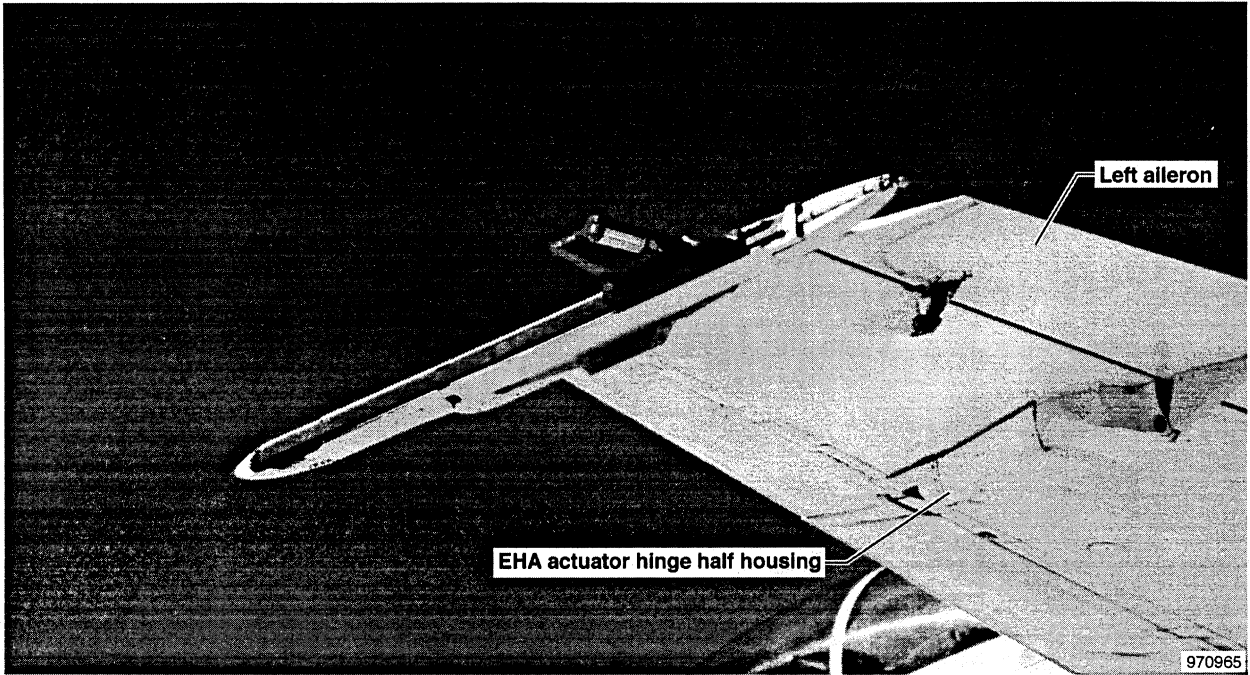

Figure 3. Hinge half housing.

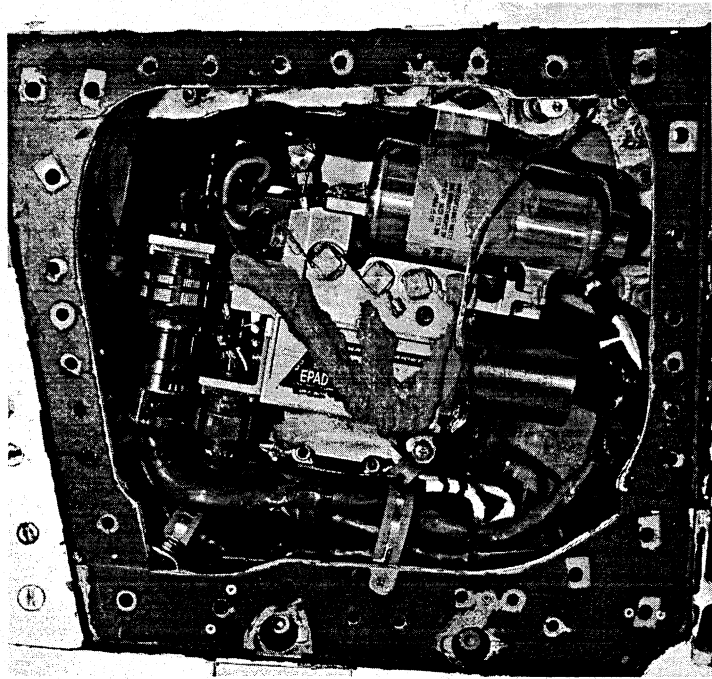
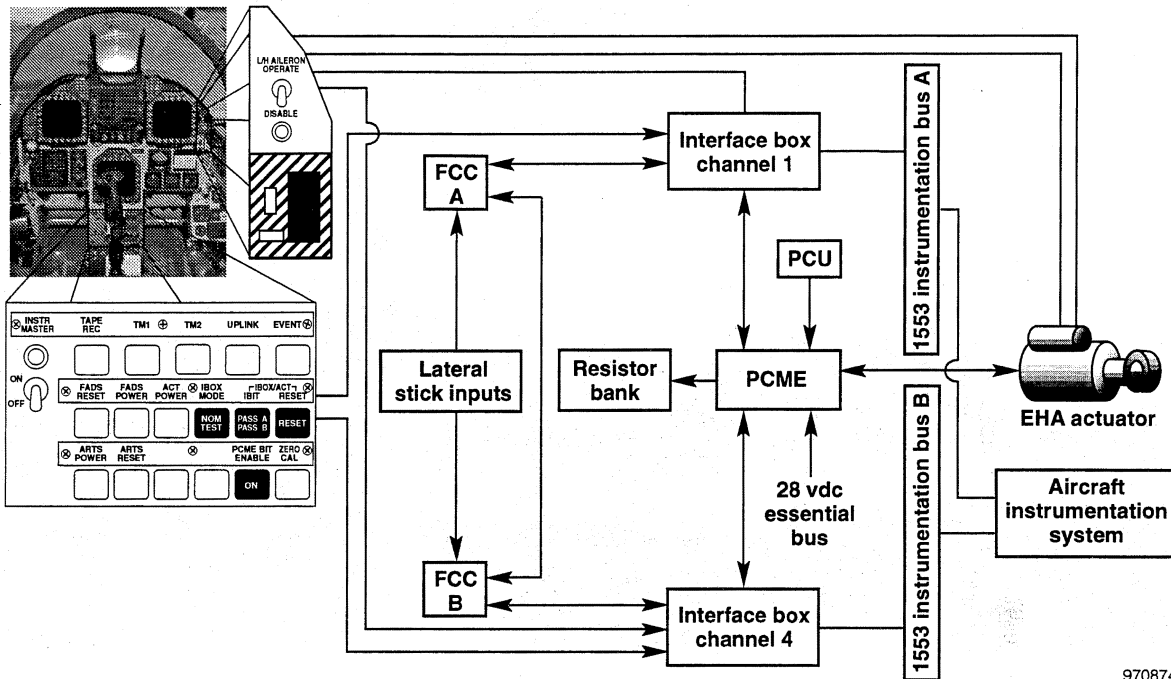
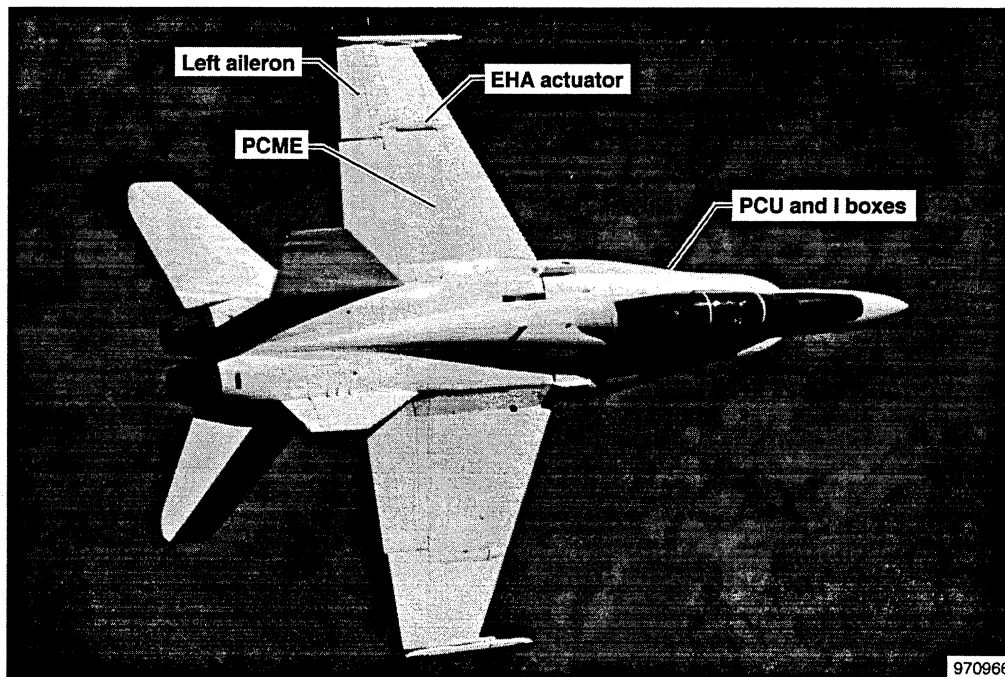

Figure 4. Electro-hydrostatic actuator installed in SRA.



970874

Figure 5. Systems Research Aircraft system architecture.



970966

Figure 6. Electro-hydrostatic actuator system component locations on SRA.

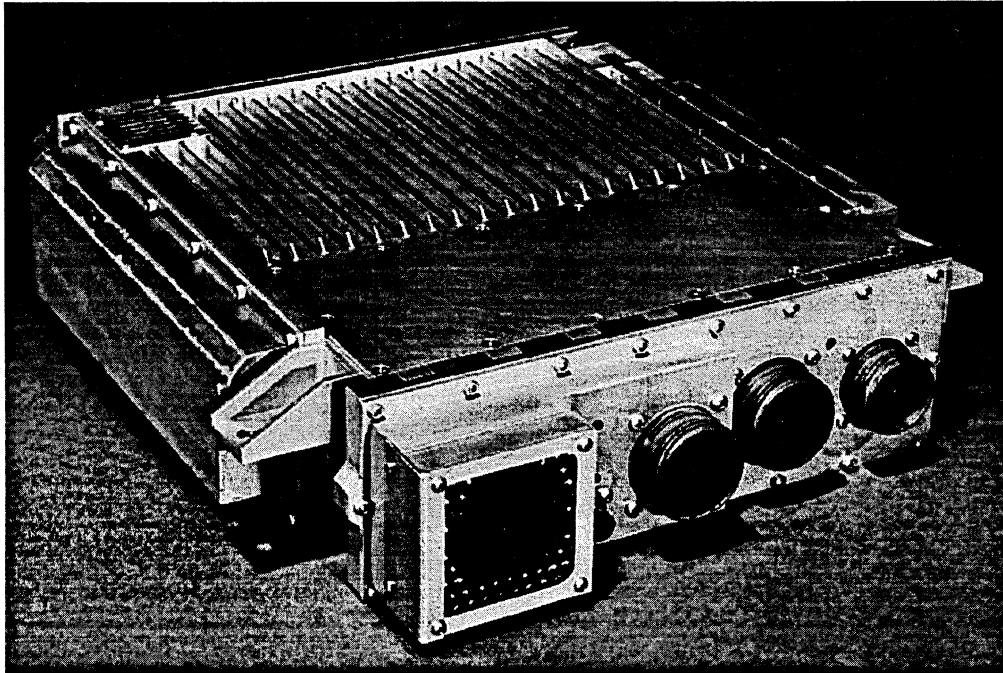

EC93-41023-03

Figure 7. Power control and monitoring electronics (PCME).



EC93 41023-09

Figure 8. Interface box (Ibox).

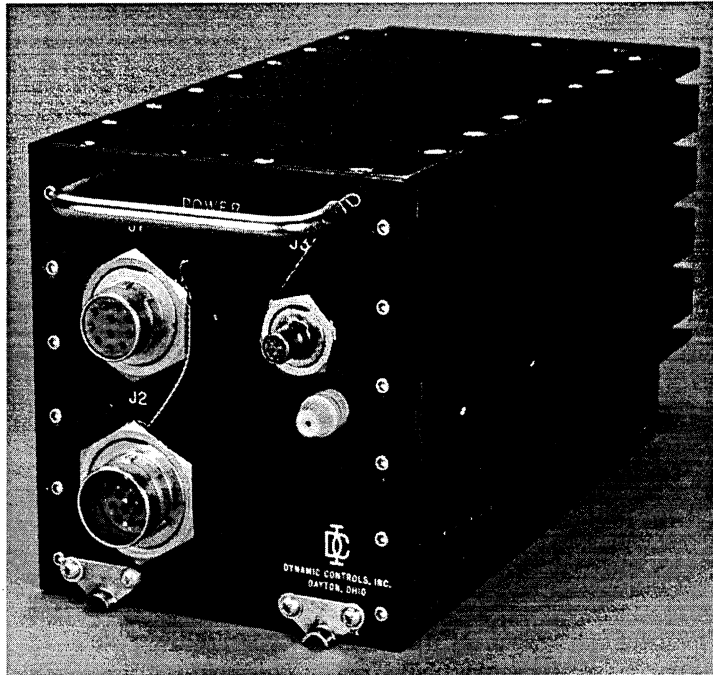

EC93 43334-01

Figure 9. Power conversion unit (PCU).

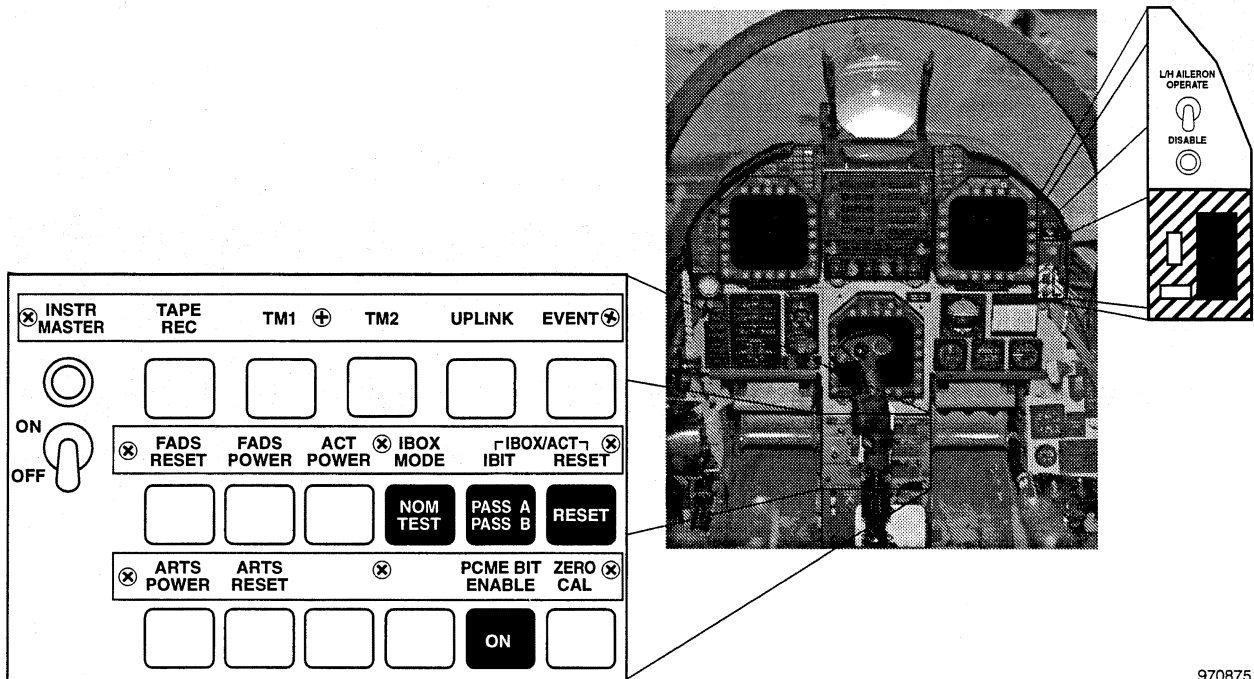
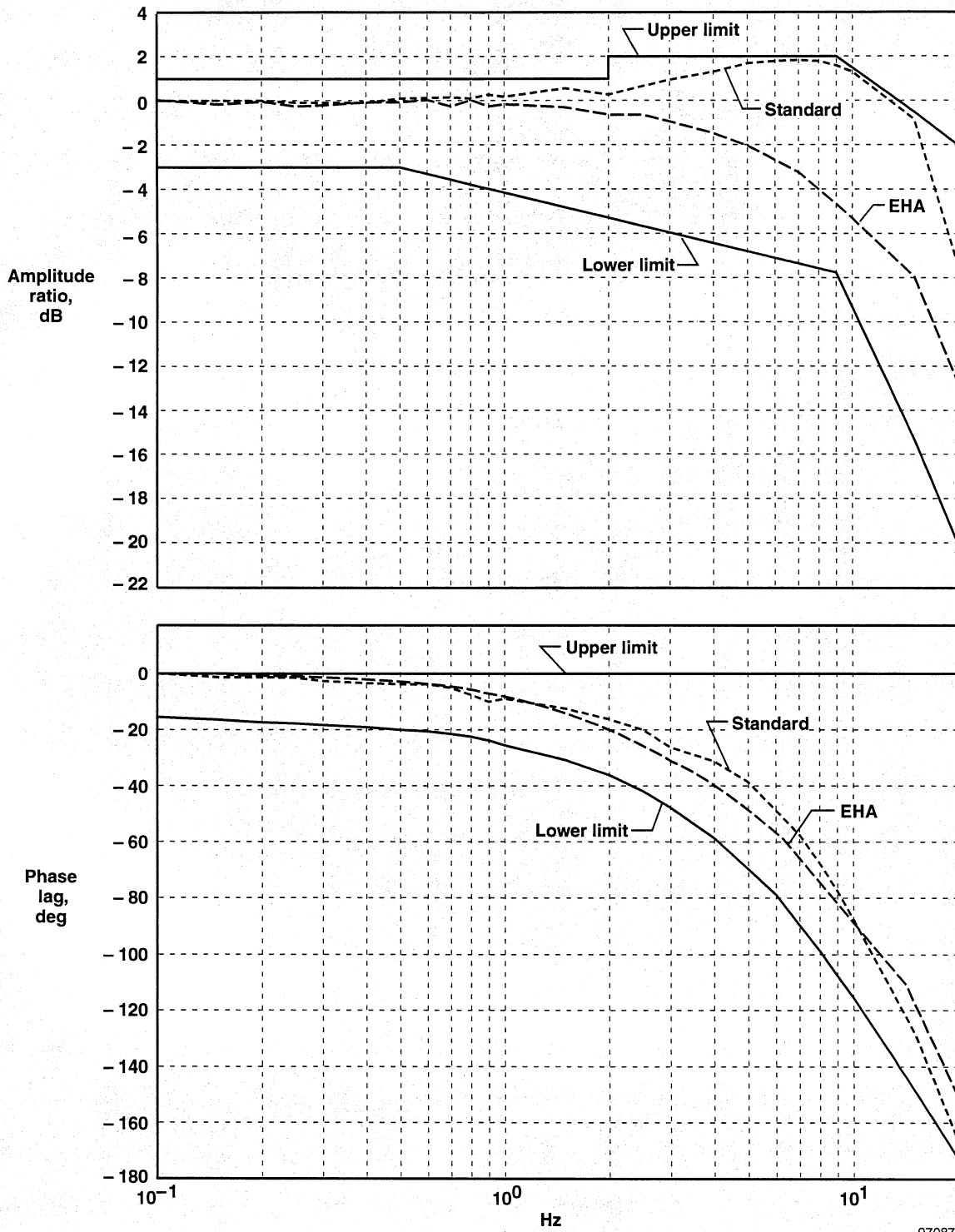

Figure 10. Electro-hydraulic actuator disable switch and control panel in cockpit.

970875



970876

Figure 11. Electro-hydrostatic actuator and standard actuator open-loop small amplitude frequency response.

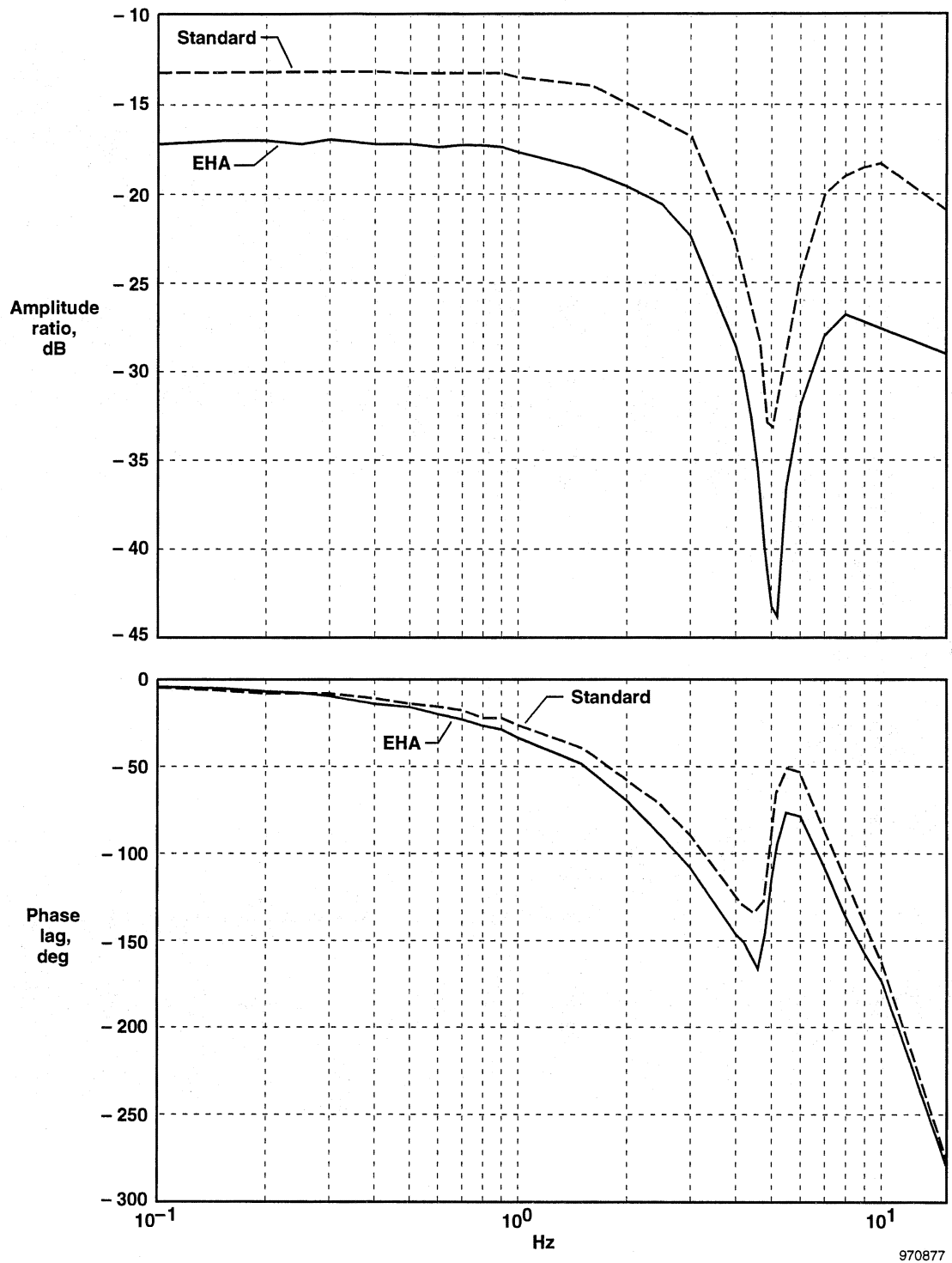

970877

Figure 12. Electro-hydrostatic actuator and standard actuator closed-loop small amplitude frequency response.

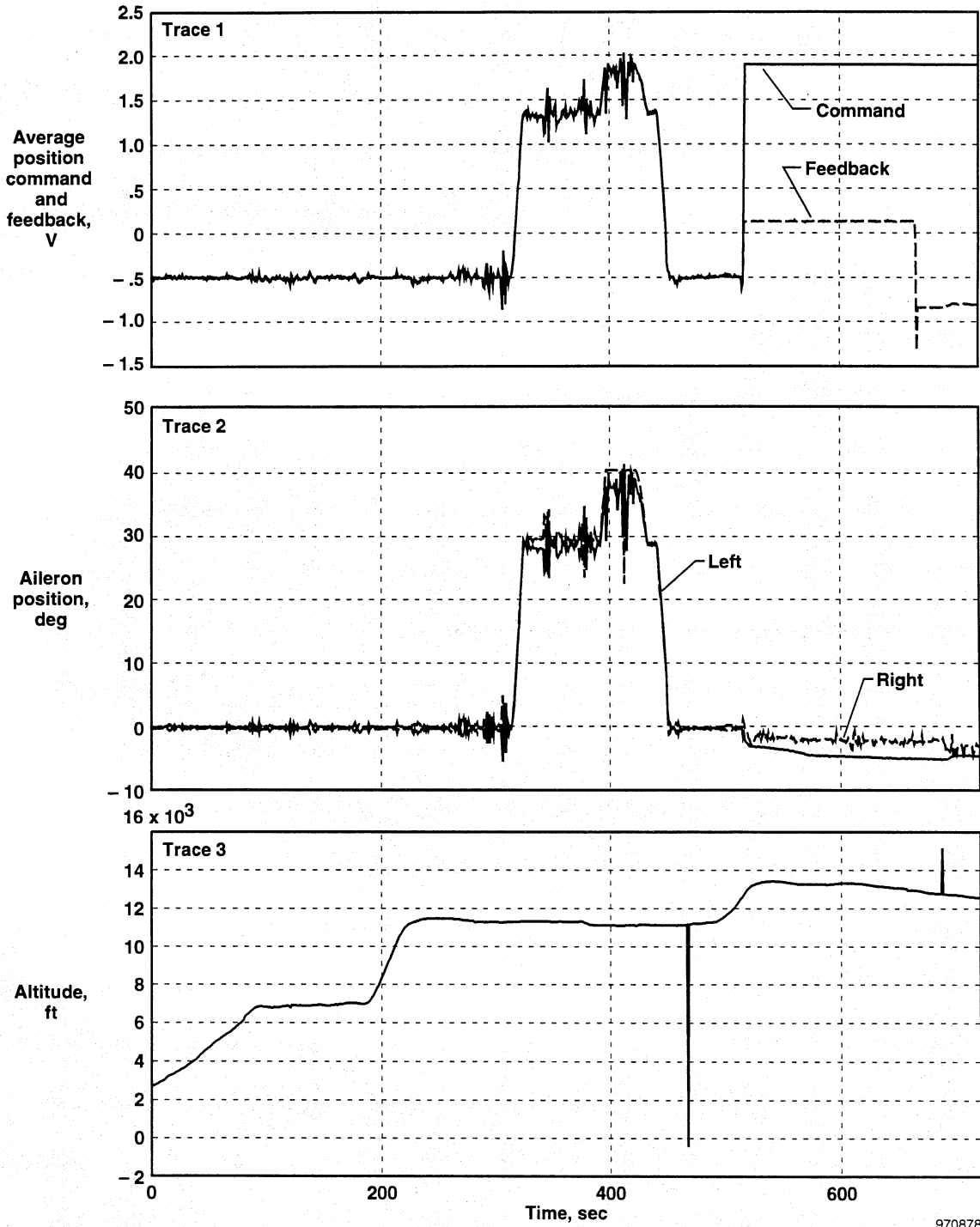

970878

Figure 13. In-flight failure, January 16, 1996, flight 564.

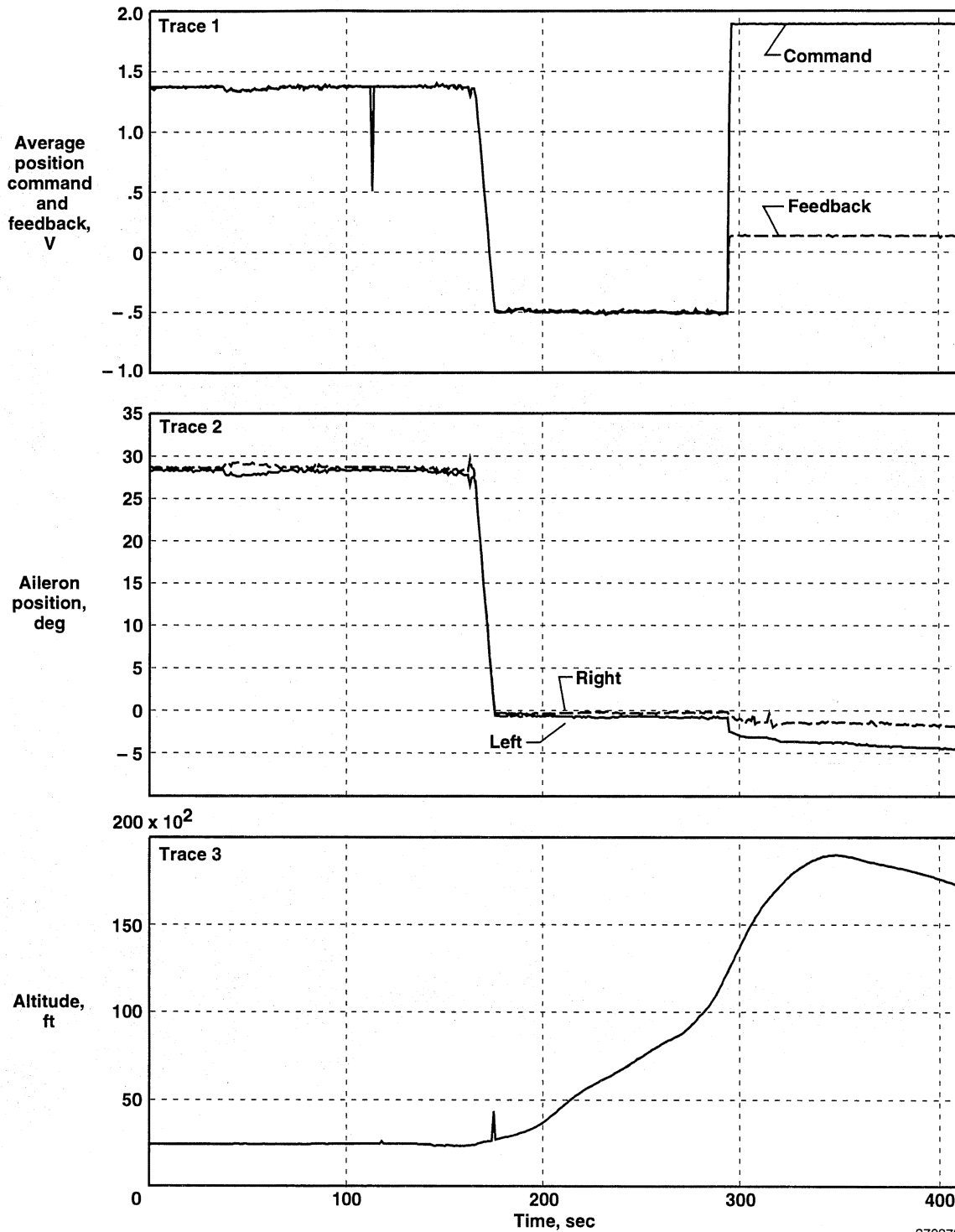

970879

Figure 14. In-flight failure, January 10, 1997, flight 585.

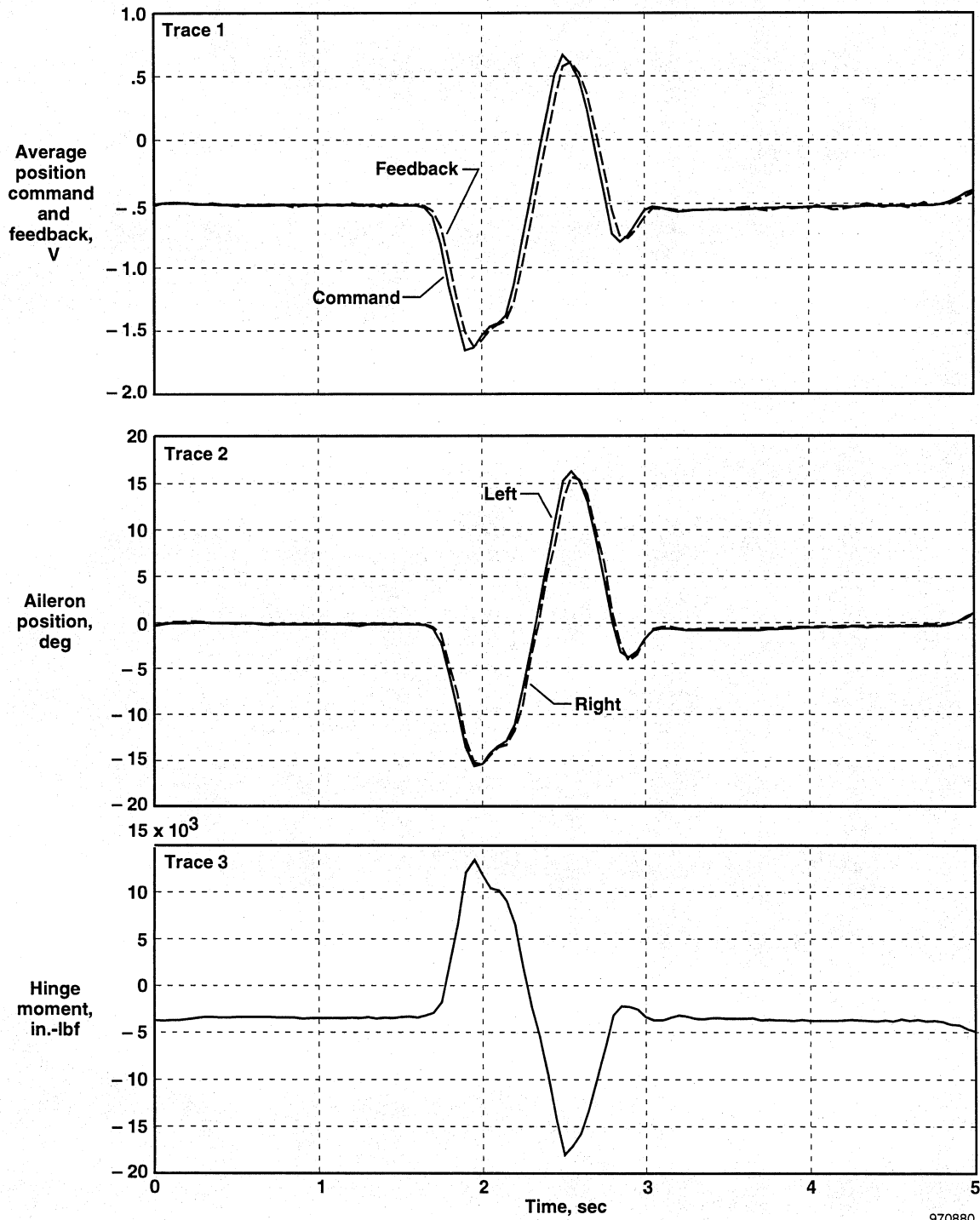

970880

Figure 15. Abrupt roll doublet—full stick (left).
 $M=0.72$, altitude=25,000 ft, $q\text{-bar}=284 \text{ lbf/ft}^2$.

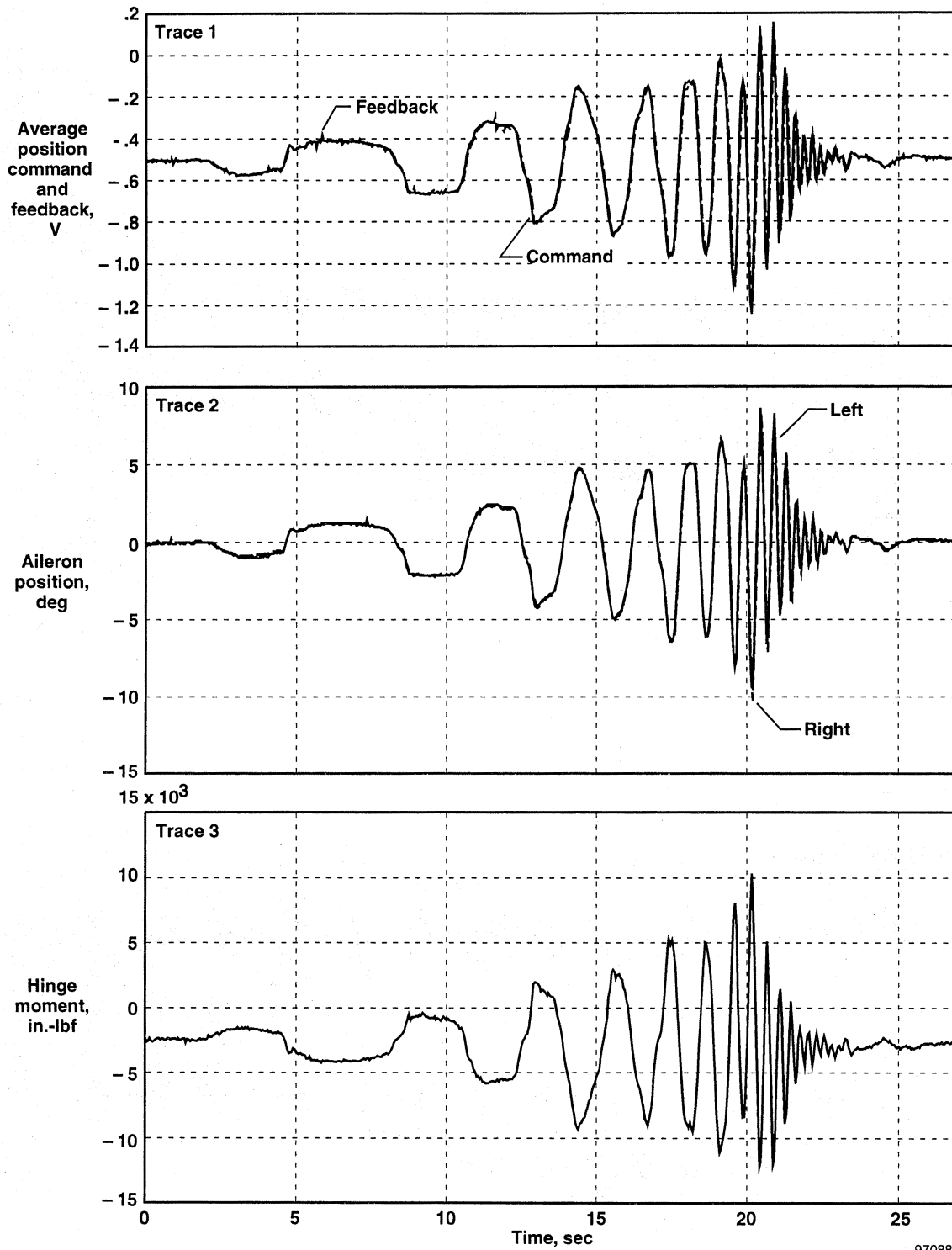

970881

Figure 16. Slow—fast lateral frequency sweep.
 $M=0.83$, altitude=25,000 ft, $q\text{-bar}=376 \text{ lbf/ft}^2$.

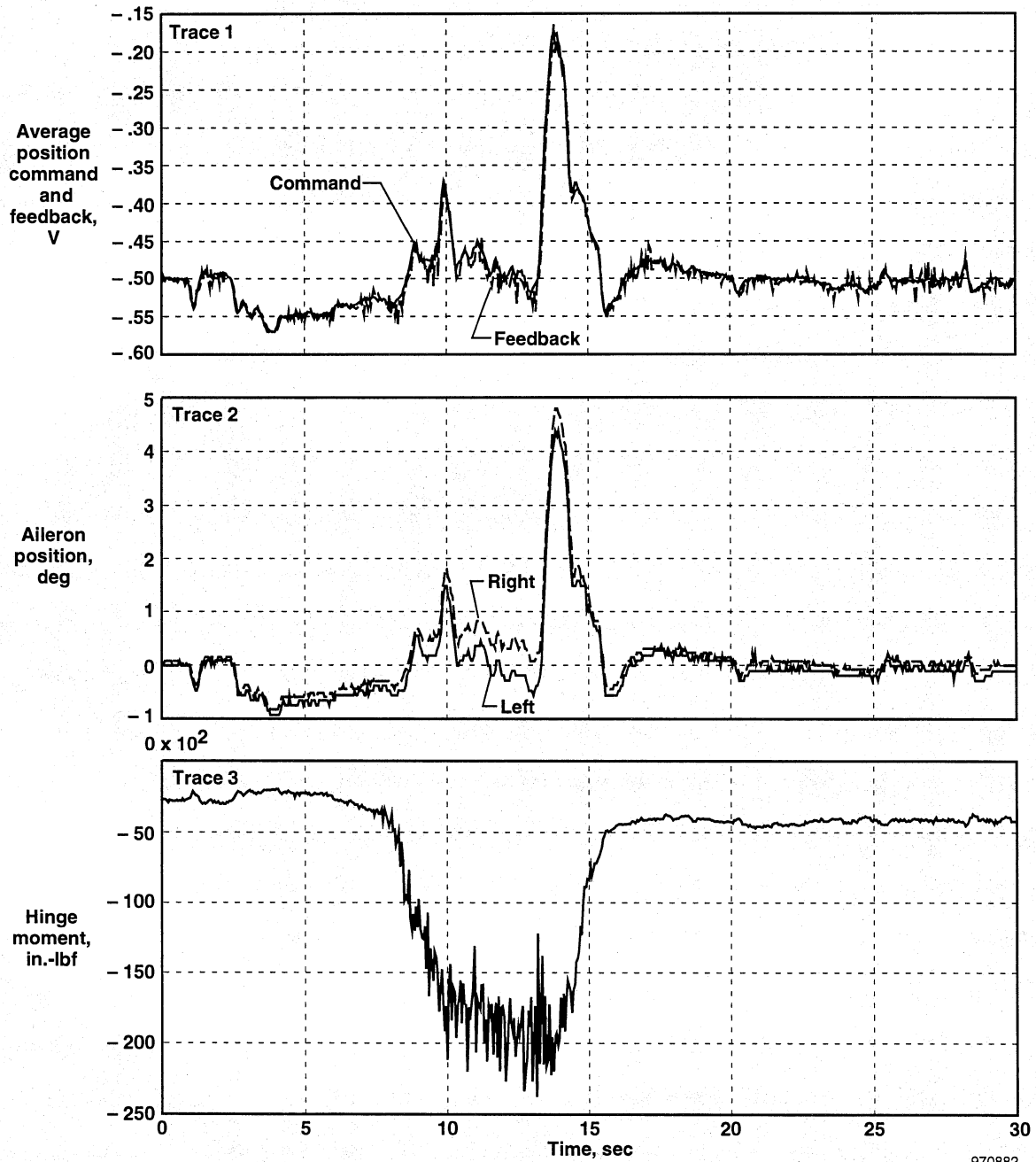

970882

Figure 17. Windup turn to $20^\circ \alpha$.
 $M=0.83$, altitude=25,000 ft, $q\text{-bar}=376 \text{ lbf/ft}^2$.

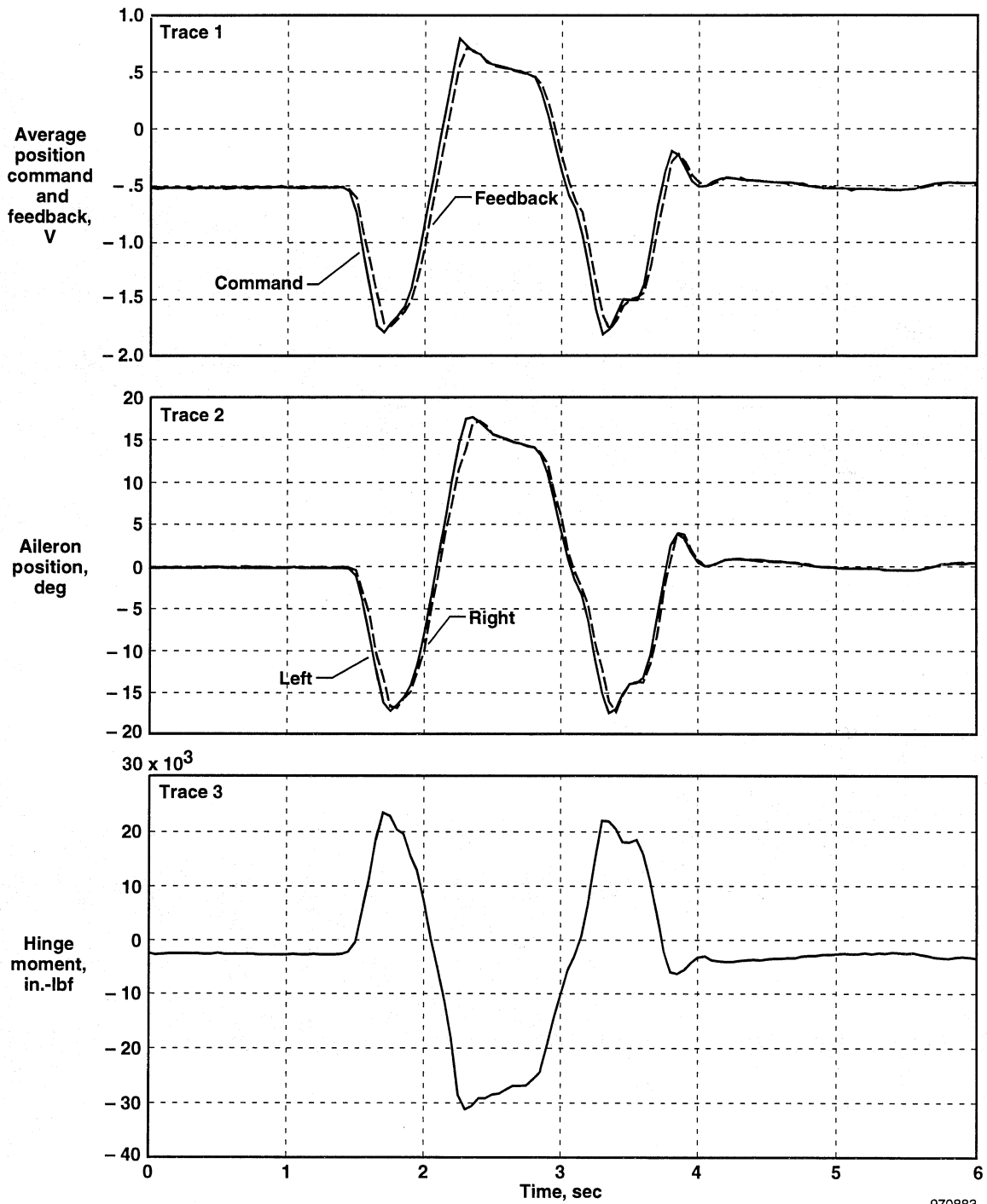

970883

Figure 18. Abrupt aileron reversal—full stick (left).

$M=0.84$, altitude=25,000 ft, $q\text{-bar}=382 \text{ lbf/ft}^2$.

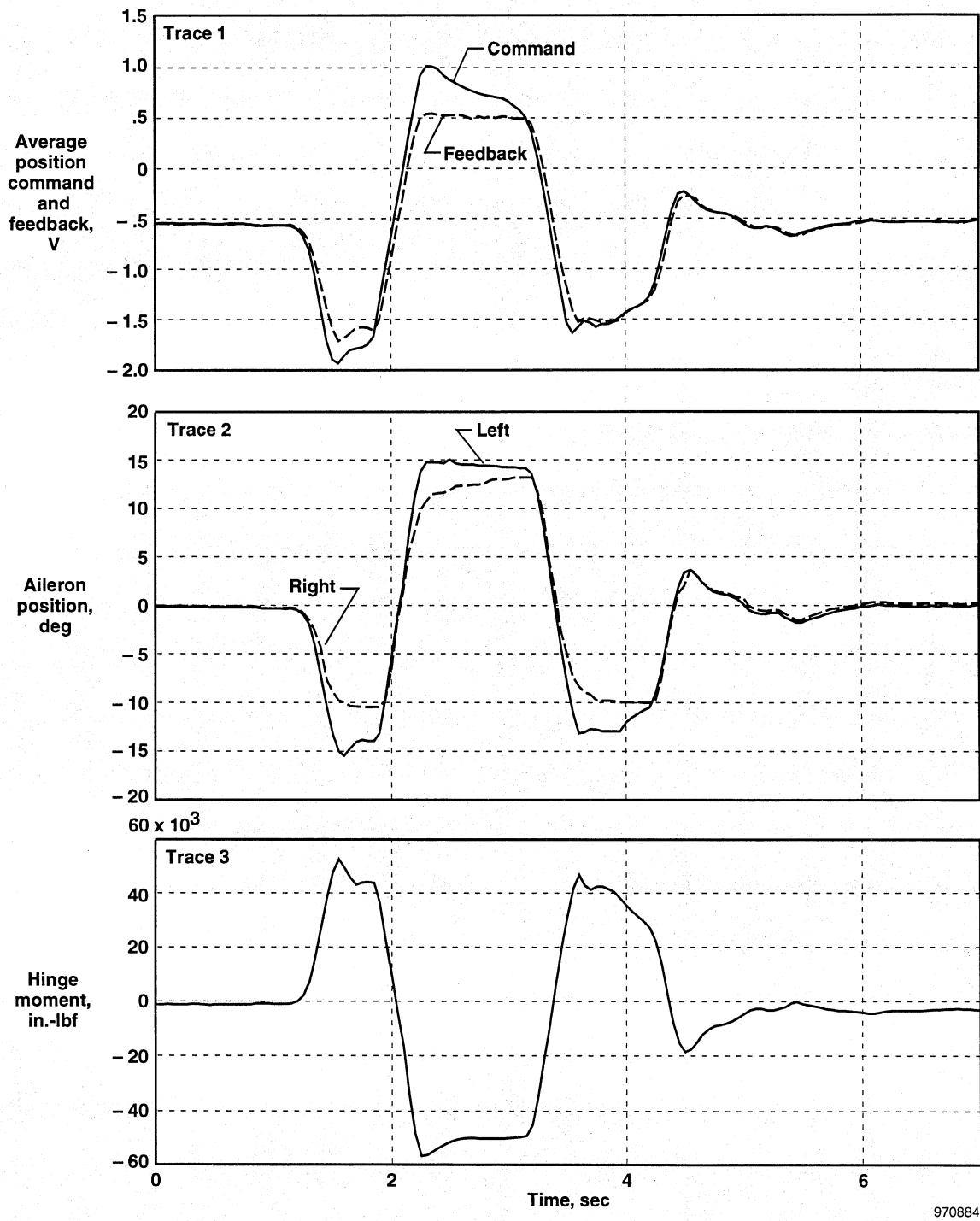

970884

Figure 19. Aileron reversal—half stick (left).
 $M=1.58$, altitude=34,000 ft, $q\text{-bar}=890$ lbf/ft².

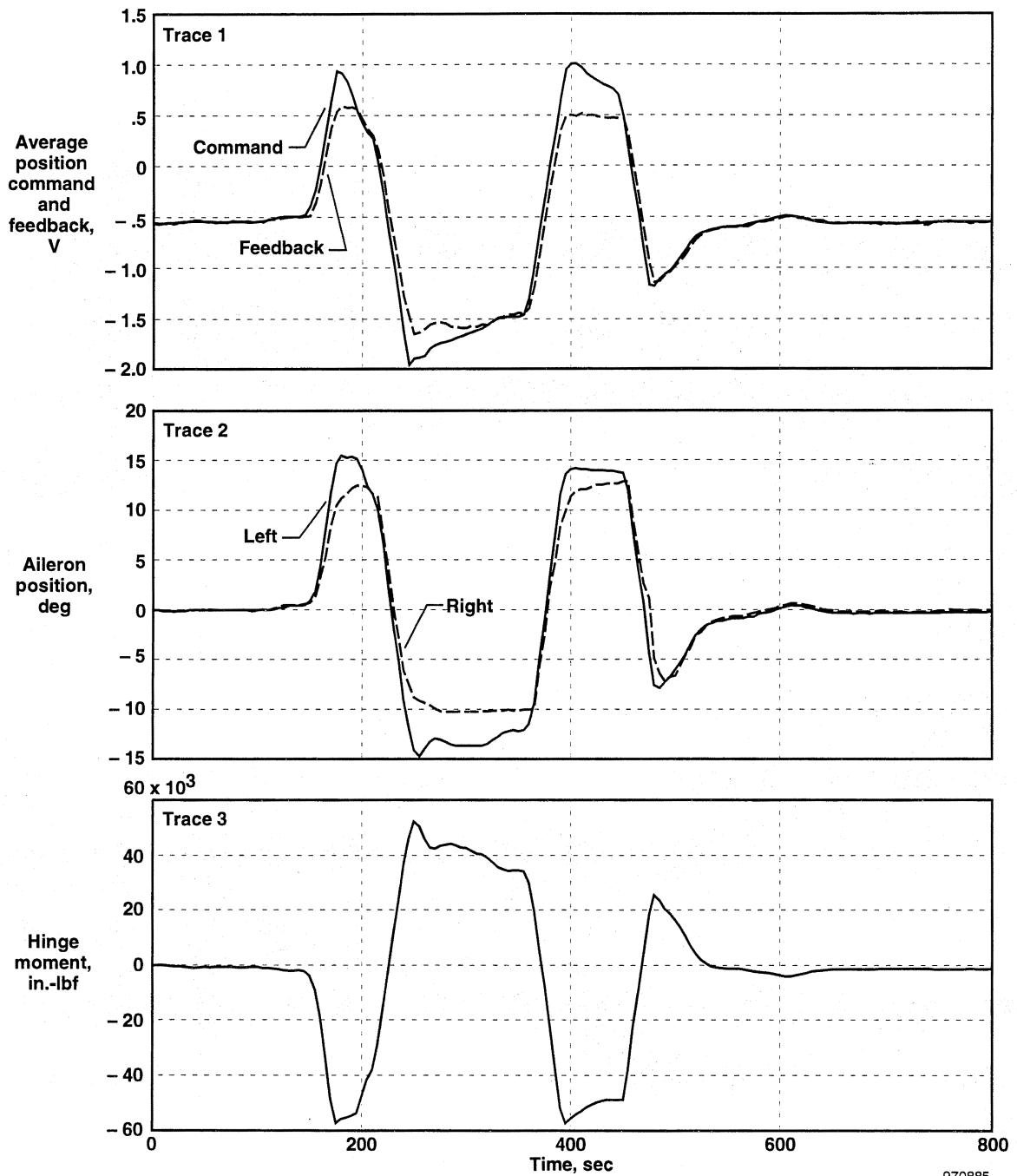

970885

Figure 20. Abrupt aileron reversal—full stick (right).

$M=1.6$, altitude=34,000 ft, $q\text{-bar}=925$ lbf/ft².

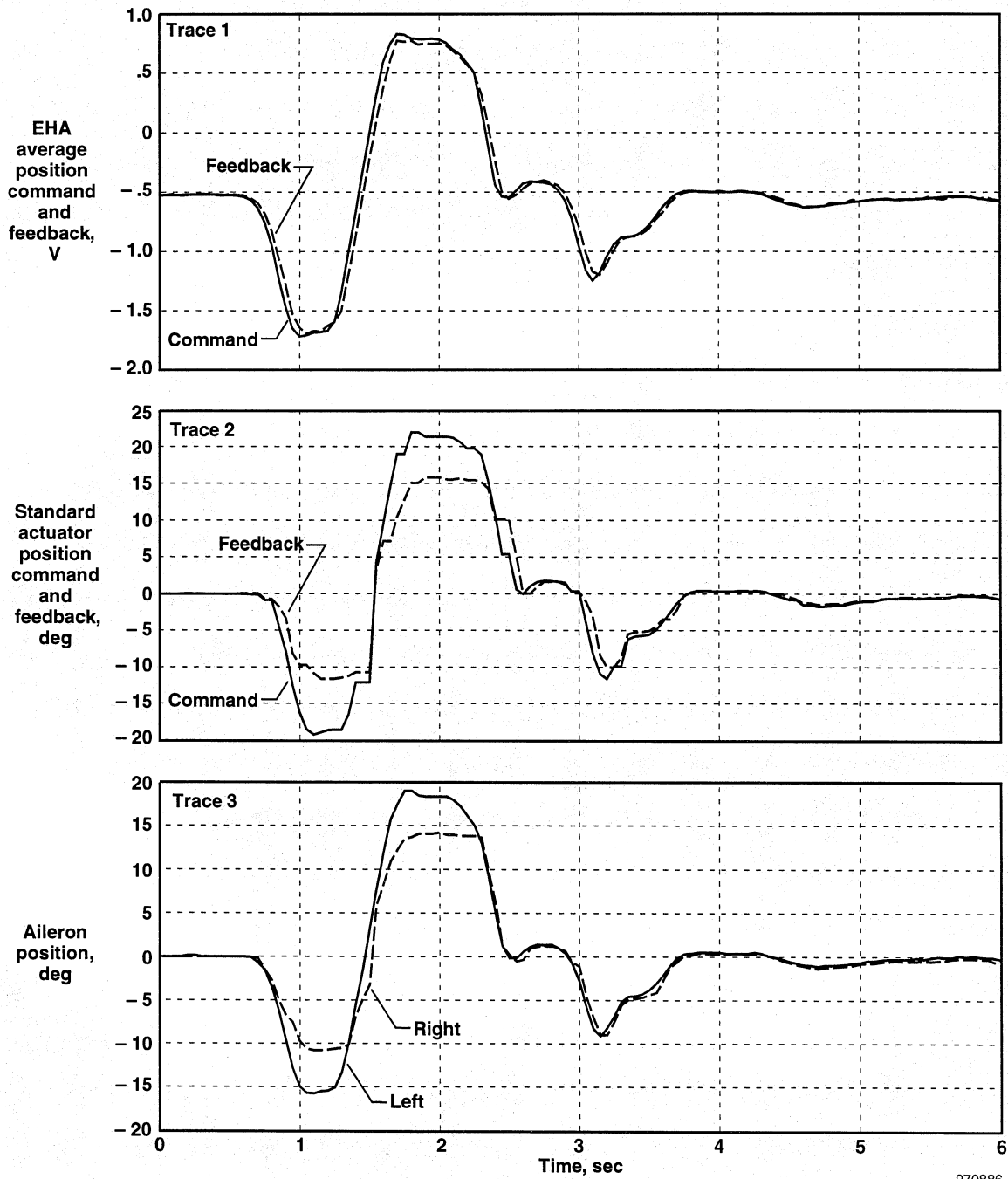

970886

Figure 21. Abrupt aileron reversal—full stick (left).

$M=0.95$, altitude=20,000 ft, $q\text{-bar}=600 \text{ lbf/ft}^2$.

REPORT DOCUMENTATION PAGEForm Approved
OMB No. 0704-0188

Public reporting burden for this collection of information is estimated to average 1 hour per response, including the time for reviewing instructions, searching existing data sources, gathering and maintaining the data needed, and completing and reviewing the collection of information. Send comments regarding this burden estimate or any other aspect of this collection of information, including suggestions for reducing this burden, to Washington Headquarters Services, Directorate for Information Operations and Reports, 1215 Jefferson Davis Highway, Suite 1204, Arlington, VA 22202-4302, and to the Office of Management and Budget, Paperwork Reduction Project (0704-0188), Washington, DC 20503.

1. AGENCY USE ONLY (Leave blank)		2. REPORT DATE October 1997	3. REPORT TYPE AND DATES COVERED Technical Memorandum	
4. TITLE AND SUBTITLE Performance of an Electro-Hydrostatic Actuator on the F-18 Systems Research Aircraft			5. FUNDING NUMBERS 529-31-14-00-36-00-SRA	
6. AUTHOR(S) Robert Navarro				
7. PERFORMING ORGANIZATION NAME(S) AND ADDRESS(ES) NASA Dryden Flight Research Center P.O. Box 273 Edwards, California 93523-0273			8. PERFORMING ORGANIZATION REPORT NUMBER H-2210	
9. SPONSORING/MONITORING AGENCY NAME(S) AND ADDRESS(ES) National Aeronautics and Space Administration Washington, DC 20546-0001			10. SPONSORING/MONITORING AGENCY REPORT NUMBER NASA/TM-97-206224	
11. SUPPLEMENTARY NOTES Presented at the 16th Digital Avionics Systems Conference, Irvine, California, October 26-30, 1997				
12a. DISTRIBUTION/AVAILABILITY STATEMENT Unclassified—Unlimited Subject Category 05			12b. DISTRIBUTION CODE	
13. ABSTRACT (Maximum 200 words) An electro-hydrostatic actuator was evaluated at NASA Dryden Flight Research Center, Edwards, California. The primary goal of testing this actuator system was the flight demonstration of power-by-wire technology on a primary flight control surface. The electro-hydrostatic actuator uses an electric motor to drive a hydraulic pump and relies on local hydraulics for force transmission. This actuator replaced the F-18 standard left aileron actuator on the F-18 Systems Research Aircraft and was evaluated throughout the Systems Research Aircraft flight envelope. As of July 24, 1997 the electro-hydrostatic actuator had accumulated 23.5 hours of flight time. This paper presents the electro-hydrostatic actuator system configuration and component description, ground and flight test plans, ground and flight test results, and lessons learned. This actuator performs as well as the standard actuator and has more load capability than required by aileron actuator specifications of McDonnell-Douglas Aircraft, St. Louis, Missouri. The electro-hydrostatic actuator system passed all of its ground tests with the exception of one power-off test during unloaded dynamic cycling.				
14. SUBJECT TERMS Electro-hydrostatic actuator, F-18 Systems Research Aircraft, performance, ground test, flight test			15. NUMBER OF PAGES 37	
			16. PRICE CODE AO3	
17. SECURITY CLASSIFICATION OF REPORT Unclassified	18. SECURITY CLASSIFICATION OF THIS PAGE Unclassified	19. SECURITY CLASSIFICATION OF ABSTRACT Unclassified	20. LIMITATION OF ABSTRACT Unlimited	

National Aeronautics and
Space Administration
Code JTT
Washington, D.C. 20546-0001
USA
Official Business
Penalty for Private Use, \$300

SPECIAL FOURTH-CLASS RATE
POSTAGE AND FEES PAID
NASA
PERMIT No G27



POSTMASTER: If Undeliverable (Section 158
Postal manual) Do Not Return

19970034702

update ~~list~~
metadata

to TM
