



International Space Station Cathode Life Testing

George C. Soulas and Timothy R. Sarver-Verhey
NYMA, Inc., Brook Park, Ohio

Prepared for the
25th International Electric Propulsion Conference
sponsored by the Electric Propulsion Society
Cleveland, Ohio, August 24-28, 1997

Prepared under Contract NAS3-27186

National Aeronautics and
Space Administration

Lewis Research Center

Available from

NASA Center for Aerospace Information
800 Elkridge Landing Road
Linthicum Heights, MD 21090-2934
Price Code: A03

National Technical Information Service
5287 Port Royal Road
Springfield, VA 22100
Price Code: A03

International Space Station Cathode Life Testing

George C. Soulas and Timothy R. Sarver-Verhey
NYMA, Inc.
NASA Lewis Research Center Group
Brook Park, OH 44142

Four hollow cathode assembly (HCA) life tests were initiated at operating conditions simulating on-orbit operation of the International Space Station plasma contactor. The objective of these tests is to demonstrate the mission-required 18,000 hour lifetime with high-fidelity development model HCAs. HCAs are operated with a continuous 6 sccm xenon flow rate and 3 A anode current. On-orbit emission current requirements are simulated with a square waveform consisting of 50 minutes at a 2.5 A emission current and 40 minutes with no emission current. One HCA test was terminated after approximately 8,000 hours so that a destructive analysis could be performed. The analysis revealed no life-limiting processes and the ultimate lifetime was projected to be greater than the mission requirement. Testing continues for the remaining three HCAs which have accumulated approximately 8,000 hours, 10,000 hours, and 11,000 hours, respectively, as of June 1997. Anode and bias voltages, strong indicators of cathode electron emitter condition, are within acceptable ranges and have exhibited no life- or performance-limiting phenomena to date.

Introduction

A hollow cathode-based plasma contactor system has been baselined for use on the International Space Station to reduce spacecraft electrical charging.¹ The plasma contactor system provides a low impedance connection to space plasma with a hollow cathode assembly (HCA). The operational requirements of the HCA include an electron emission capability of up to 10 A and an operational lifetime of 18,000 hours.¹ Several component-level tests, including a hollow cathode² and cathode heater³ life tests and an accelerated ignition life test,⁴ are being conducted to demonstrate compliance to mission requirements.

The objective of the life tests described in this paper is to demonstrate the mission-required 18,000 hour lifetime with high-fidelity development model HCAs. Four development model HCAs are being tested with conditions simulating on-orbit operation. Because fabrication of the spaceflight HCAs needed to be initiated prior to completion of the life tests, one of the tests was terminated after approximately 8,000 hours so that a destructive analysis could be performed. This was done so that confidence could be established in its design.

Apparatus

Hollow Cathode Assembly

A development model HCA is shown in Fig. 1 and is described in detail in Ref. 1. The four development model HCAs used in this test program are designated HCA-003, -006, -010, and -013. Slight differences

between the development model and spaceflight designs exist. The differences are minor (e.g. HCA-003 and -006 have different mounting flanges and electrical connectors), however the designs are functionally identical. Hence, these differences do not impact the validity of the life test results described herein.

Configuration and Power Supplies

Each HCA emits current to an external anode that acts as a bias for extracting the simulated spacecraft charge control current. A photograph and schematic of a HCA-bias anode arrangement are shown in Figs. 1 and 2, respectively. Each HCA has a bias plate that is mounted downstream of the HCA. All HCA-bias anode arrangements and their respective power supplies are electrically isolated from each other, and from vacuum facility ground. Commercial power supplies are used to operate the HCA heater and discharge. A breadboard ignitor supply⁵ is used to ignite all HCA discharges.

Test Support Hardware

The xenon gas feed systems, vacuum facility, and instrumentation are described in detail in Ref. 6. Parameters monitored during life testing include currents, voltages, xenon flow rates, and vacuum pressures.

Test Procedures and Operating Conditions

Cathode conditioning and ignition procedures used in these tests are the same as those for the spaceflight HCAs.¹ Whenever the HCA was exposed to air, cathode conditioning procedures were conducted to remove contaminants from the cathode electron emitter prior to

testing.⁶ The HCA discharge was ignited by initiating xenon flow and powering the anode and ignitor power supplies after heating the cathode for a fixed period.⁴ Once ignition occurred, the ignitor and heater power supplies were turned off and the discharge was allowed to stabilize. A performance evaluation of the HCA was then typically conducted during which anode voltages were measured as a function of xenon flow rate at a fixed anode current. The life test was then initiated (or resumed).

HCA operating conditions are listed in Table 1. On average, the Space Station will require electron emission current from the HCA for approximately 50 minutes of the 90 minute orbital period.⁷ Because the HCA is a self-regulating device, the emission current is controlled by the space plasma potential. In this test program, the emission current is controlled by the bias power supply and the resulting voltage is monitored. Although the HCA is designed to provide an electron emission current of up to 10 A, the maximum sustained electron emission current is anticipated to be approximately 2.5 A during this 50 minute period, termed the emission period.⁷ During the remaining 40 minutes of the orbit, termed the idle period, no electron emission current is required. The on-orbit operating sequence is thus simulated with a square waveform consisting of 50 minutes at a 2.5 A bias current and 40 minutes with no bias current. This bias current square waveform is repeated, while the anode current and xenon flow rate are maintained at 3 A and 6 sccm, respectively.

Although the majority of testing was conducted with the nominal operating conditions described above, there were deviations to these conditions at the start of life testing. Life testing was first initiated on HCA-006 at a 2 A anode current. After 1,100 hours of life testing, the anode voltage exhibited unstable behavior during idle periods. This behavior worsened until testing was interrupted at hour 1,672. Investigations revealed that the unstable voltage was due to a low cathode electron emitter temperature. An anode current of 3 A was found to provide stable operation with appropriate margin. This current was, subsequently, used as the operating condition.

HCA-006 was also initially operated with a 30 minute emission period. A plane change in the proposed Space Station orbit, however, resulted in an increase in the required emission period to 50 minutes. This change was implemented on HCA-006 at hour 2,863.

Life testing was initiated on HCA-003, -010, and -013 after hour 2,863 of HCA-006. These HCAs were, therefore, operated with a 3 A anode current and 50 minute emission period, as indicated in Table 1.

HCA-010 was briefly operated in an on-off mode to support a plasma contactor system trade study examining xenon usage. During operation in this mode, the HCA discharge was ignited just prior to each

emission period and extinguished at the start of each idle period. The on-off mode was initiated at hour 2,370 and was changed back to continuous-on mode after hour 6,445.

Results and Discussion

To date, there have been 30 test interruptions, all unrelated to HCA operation. The interruptions occurred as a result of facility or test support equipment failures, and they have not affected the performance of the HCAs.

Typical anode and bias potential profiles are shown in Fig. 3. Because anode and bias voltages reach stable values at the end of idle and emission periods, these end-of-period voltages are plotted against accumulated operating time to simplify analysis of HCA condition. These data along with ignition times and performance evaluations (i.e. anode voltages as a function of xenon flow rate) are used to assess the condition of each HCA during life testing.

HCA Performance Evaluations

Figure 4 shows performance evaluation profiles for each HCA. HCA anode voltages were averaged from all profiles measured to date. As Fig. 4 shows, all HCAs have exhibited similar behavior, with minor differences attributable to differences in cathode-anode spacing. Performance evaluation voltages at 6 sccm have varied within a maximum bandwidth of 5.5 V over the course of the life tests. This bandwidth is similar to that observed in a successful 28,000 hour hollow cathode life test.²

Life Test Performance

HCA-006 accumulated 8,030 hours of operation, after which testing was voluntarily interrupted. HCA-003, -010, and -013 have accumulated 10,860, 7,766, and 10,254 hours of operation, respectively, as of June 1997. Figures 5-8 show the anode and bias voltages at the end of idle and emission periods for each HCA. Indications of performance degradation, such as increasing anode or bias voltages with accumulated operating time, have not been observed in any of the testing to date. Maximum end-of-period anode and bias voltage bandwidths for each HCA are shown in Table 2. HCA anode and bias voltages have varied within a maximum bandwidth of 5.2 V.

The time required to ignite the HCA discharge from the application of cathode heater power has generally been less than 6 minutes for all HCAs, which is characteristic for this HCA design.¹ Ignition times for HCA-010 were typically within 3.7-4.0 minutes during the 4,358 ignitions accumulated in on-off mode. Ignition times greater than 6 minutes occurred during the initial

series of ignitions following HCA fabrication, which is typical,¹ and during the most recent HCA-003 ignition, which was approximately 12 minutes. The cause for the recent increase in the HCA-003 ignition time is unknown and its effect on the condition of the HCA is also unclear because anode and bias voltages have been nominal to date. The cause of this increase is presently being investigated.

HCA Destructive Analysis

The testing of HCA-006 was voluntarily terminated at hour 8,030 so that a destructive analysis could be performed. The analysis included visual inspections, measurements of critical dimensions, scanning electron microscopy for surface, weld joint, and braze joint conditions, and an energy dispersive x-ray analysis for surface chemistry and deposition.

Critical dimensions, including the cathode and anode orifice diameters and channel lengths, exhibited negligible changes. Pre- and post-test photographs of the downstream cathode orifice plate are shown in Fig. 9. Although the orifice plate surface was noticeably textured from ion bombardment, some surface scratches incurred during its fabrication were still visible. No erosion of the heater was found, including the downstream end closest to the discharge. Neither the anode nor cathode orifice channels showed significant erosion or deposition. The upstream cathode orifice plate exhibited no erosion and only some surface deposition. This deposition consisted of cathode electron emitter and tube material.

The conditions of the anode and cathode plates and their orifice dimensions lead to two conclusions about HCA operating conditions. First, any contaminants within the xenon gas, such as oxygen- and carbon-bearing compounds, were insufficient to limit cathode life. None of the wear phenomena associated with a contaminated cathode, such as deposition of volatilized emitter material within the orifice channel and on the upstream cathode plate surface,⁸ were observed. Second, the selection of operating parameters (i.e. xenon flow rate and anode current) and of critical cathode and anode dimensions (i.e. orifice diameters and channel lengths) were appropriate for the operating conditions.

The conditions of both cathode and anode tube-to-disc weld joints and all braze joints exhibited negligible changes. Although there was metallic deposition on the upstream and downstream surfaces of the isolator between the cathode and anode, no conduction path was formed and the condition of the isolator suggests that this deposition mechanism will not be a significant issue for the spaceflight HCAs.

A photograph of the electron emitter interior surface is shown in Fig. 10. Visual inspection of the surface found it to be in good condition. None of the

large depositions and formations which resulted in life issues in previous tests^{8,9} were identified. The Fig. 10 photograph and schematic show impregnate coating the upstream region along approximately 75% of the overall emitter length. The remaining downstream region exhibited formations that could be divided into three equally spaced regions. These regions included (from upstream to downstream): 1) large deposits of impregnate; 2) barium-tungsten formations; and 3) tungsten crystal formations and increased surface porosity. These formations and depositions are consistent with a successful, short duration test operated at a higher emission current.⁸

In summary, critical cathode and anode dimensions remained unchanged after 8,030 hours of operation. The electron emitter surface also appeared to be in good condition. Finally, all other critical design features such as the heater, cathode and anode weld joints, braze joints, and the isolator were intact and showed no life- or performance-limiting phenomena. From these findings, the ultimate lifetime was projected to be greater than the 18,000 hour mission requirement.

Conclusions

Four hollow cathode assembly life tests were initiated at operating conditions simulating on-orbit operation of the International Space Station plasma contactor. The objective of these tests is to demonstrate the mission-required 18,000 hour lifetime with high-fidelity development model HCAs. Emission current requirements are simulated with a square waveform consisting of 50 minutes at a 2.5 A emission current and 40 minutes with no emission current. One of the HCAs was tested for 8,030 hours, after which a destructive analysis was performed. The destructive analysis revealed no significant life- or performance-limiting phenomena and the ultimate lifetime was projected to be greater than the 18,000 hour mission requirement. Testing continues on the three remaining HCAs which have accumulated 10,860 hours, 7,766 hours, and 10,254 hours, respectively, as of June 1997. Ignition times from the application of cathode heater power have generally been less than 6 minutes. Anode and bias voltages are within acceptable ranges and have exhibited no life- or performance-limiting phenomena to date.

References

¹Patterson, M.J., et al., "Space Station Cathode Design, Performance, and Operating Specifications," IEPC Paper No. 97-170, August 1997.

²Sarver-Verhey, T.R., "28,000 hour Xenon Hollow Cathode Life Test Results," IEPC Paper No. 97-168, August 1997.

³ Soulas, G.C., "Status of Hollow Cathode Heater Development for the Space Station Plasma Contactor," AIAA Paper No. 94-3309, July 1994.

⁴ Zakany, J.S. and Pinero, L., "International Space Station Cathode Ignition Testing Status at 32,000 Cycles," IEPC Paper No. 97-167, August 1997.

⁵ Hamley, J.A., et al., "Development of a Power Electronics Unit for the Space Station Plasma Contactor," IEPC Paper No. 93-052, September 1993.

⁶ Soulas, G.C., "Multiple Hollow Cathode Wear Testing for the Space Station Plasma Contactor," AIAA Paper No. 94-3310, June 1994.

⁷ Personal Communication, Katz, I., S-Cubed Division of Maxwell Labs, San Diego, CA, July 1994.

⁸ Verhey, T.R. and Patterson, M.J., "Microanalysis of Extended-Test Xenon Hollow Cathodes," AIAA Paper No. 91-2123, June 1991.

⁹ Sarver-Verhey, T.R., "Extended Testing of Xenon Ion Thruster Hollow Cathodes," AIAA Paper No. 92-3204, July 1992.

Table 1 Life test operating conditions

HCA Designation	Life Test Hours ^a	On-off Cycles ^b	Anode Current, A	Bias Current, A	Emission Period, min	Idle Period, min	Comments
HCA-006	0-1,672	0	2	2.5	30	60	Low Anode Current & Reduced Emission Period
	1,672-2,863	0	3	2.5	30	60	
	2,863-8,030	0	3	2.5	50	40	
HCA-003	0-10,860	0	3	2.5	50	40	
HCA-010	0-2,370	0	3	2.5	50	40	HCA On-Off Operation
	2,370-6,445	4,358	3	2.5	50	40	
	6,445-7,766	0	3	2.5	50	40	
HCA-013	0-10,254	0	3	2.5	50	40	

^a As of June 1997. Testing is on-going for HCA-003, -010, and -013.

^b HCA discharge is extinguished during the idle periods.

Table 2 Life test voltage bandwidths

HCA Designation	Accumulated Hours ^a	Idle Period Anode, V	Voltage Bandwidths	
			Emission Period Anode, V	Bias, V
HCA-003	10,860	4.6	2.3	3.2
HCA-006 ^b	8,030	2.7	1.7	1.8
HCA-010	7,766	5.2	4.2	3.4
HCA-013	10,254	5.2	3.5	3.3

^a As of June 1997.

^b As of hour 1,672.

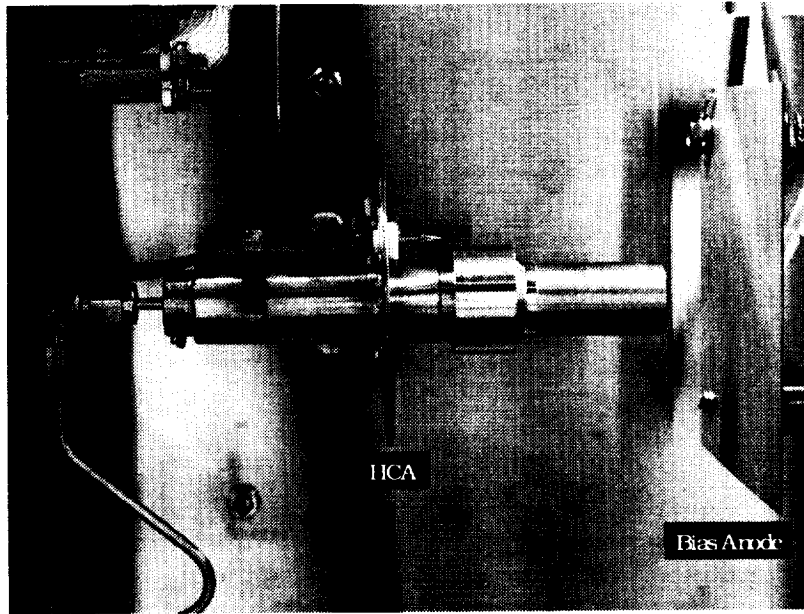

Fig. 1 Photograph of an HCA-bias anode arrangement.

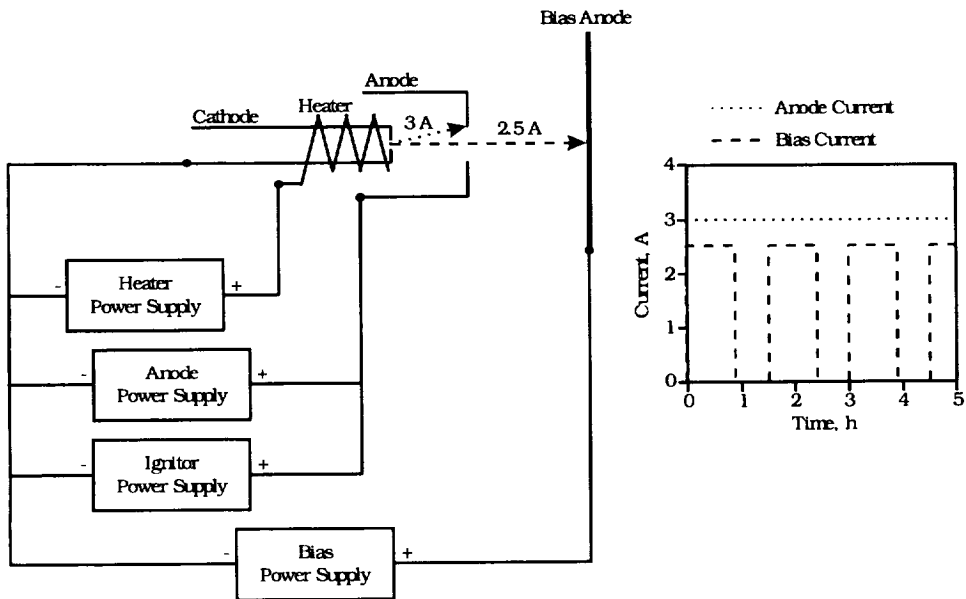

Fig. 2 Schematic of the HCA-bias anode arrangement and current profiles.

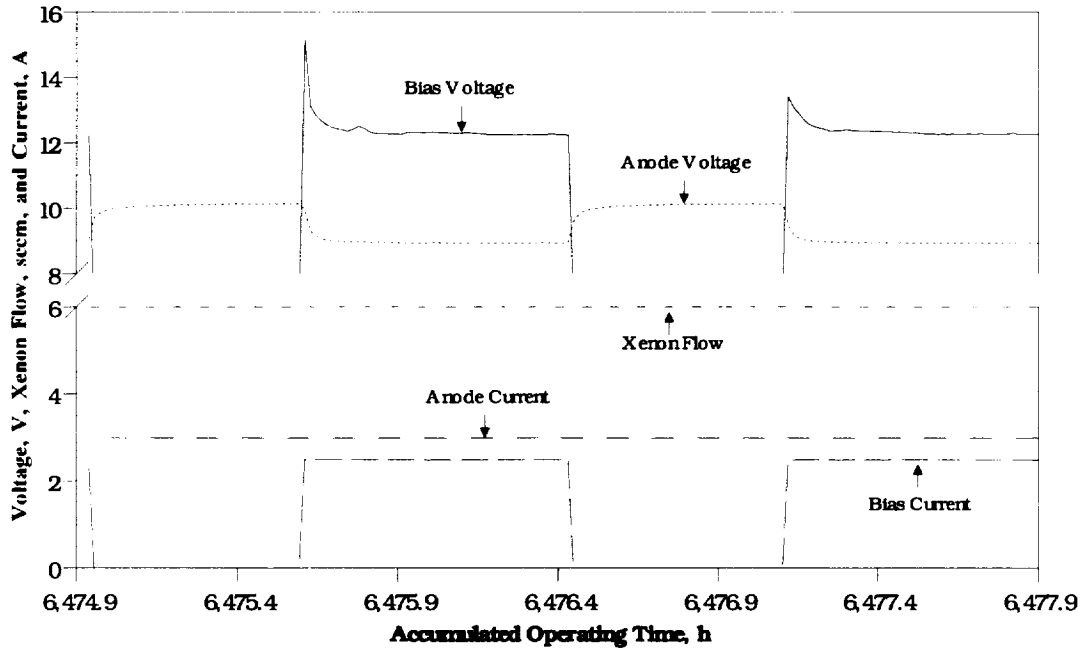

Fig. 3 Typical anode and bias voltages throughout life testing for HCA-010.

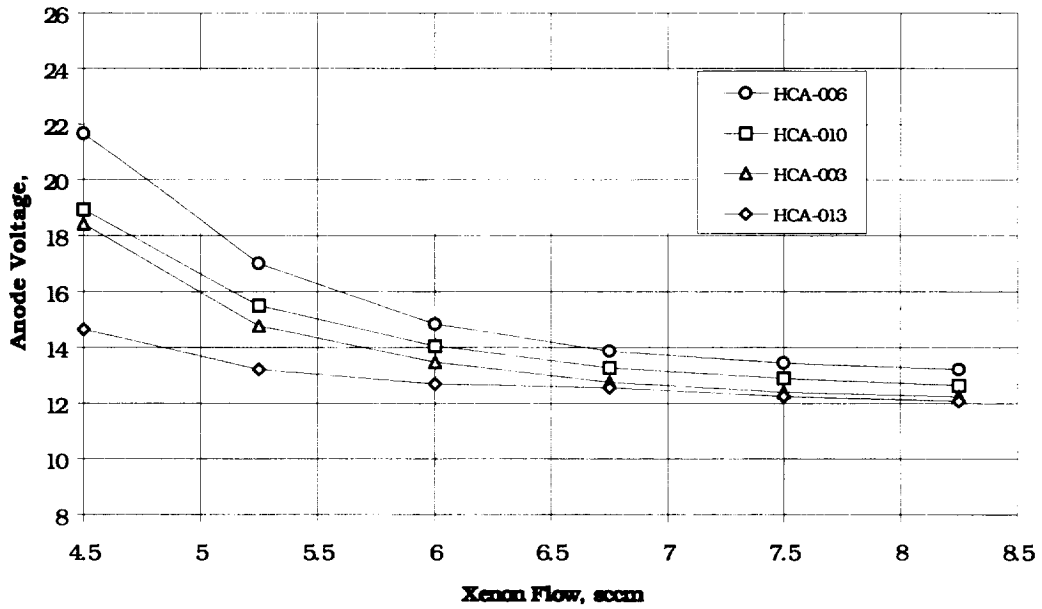

Fig. 4 Performance evaluation profiles at a 3 A anode current.

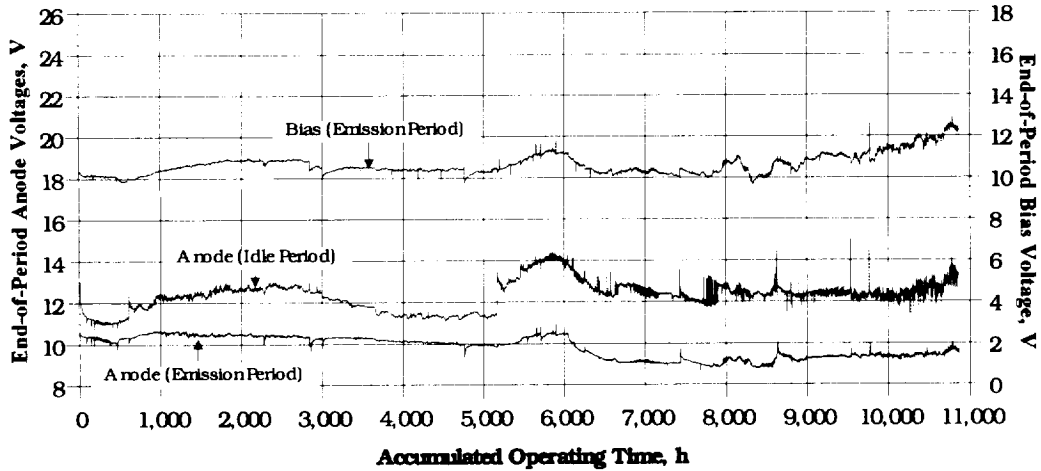

Fig. 5 HCA-003 life test anode and bias voltages at the end of idle and emission periods.

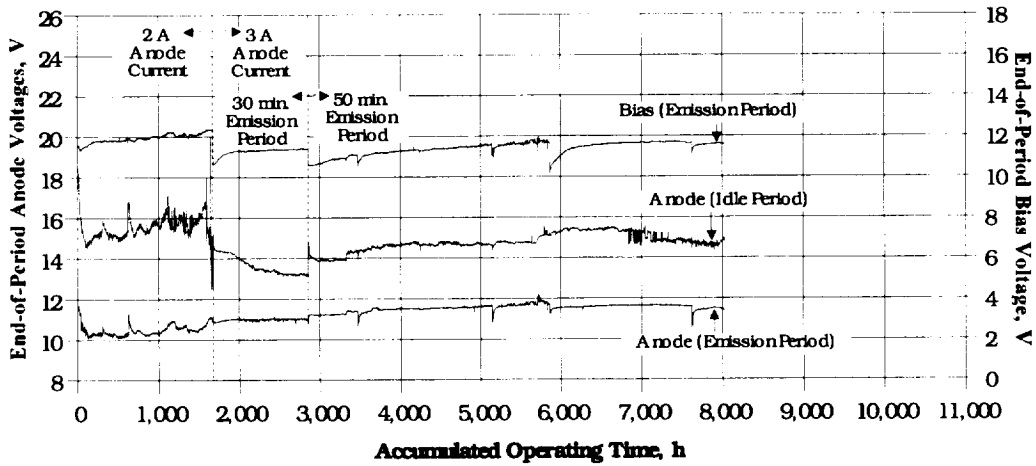

Fig. 6 HCA-006 life test anode and bias voltages at the end of idle and emission periods.

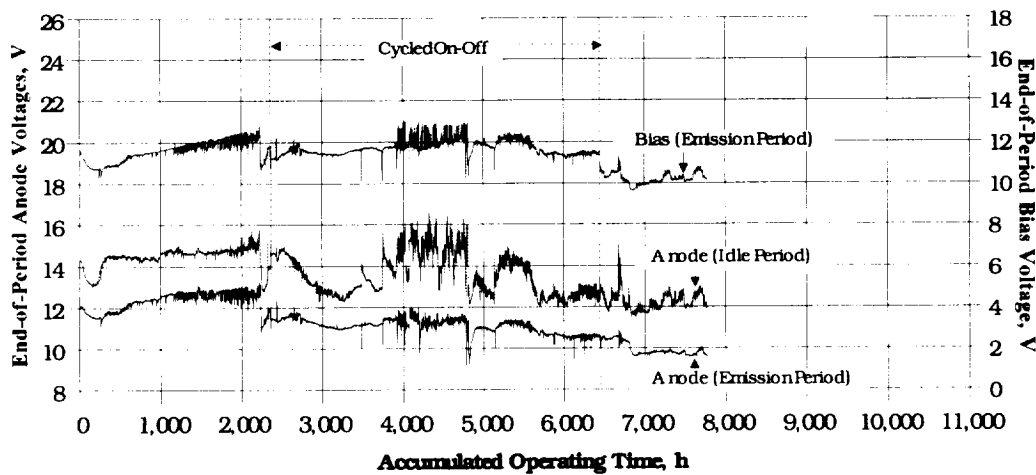

Fig. 7 HCA-010 life test anode and bias voltages at the end of idle and emission periods.

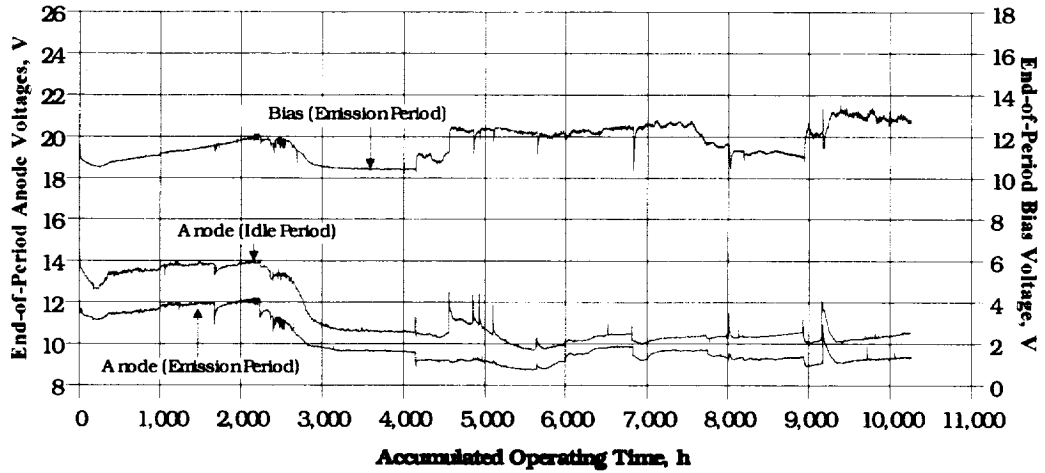

Fig. 8 HCA-013 life test anode and bias voltages at the end of idle and emission periods.

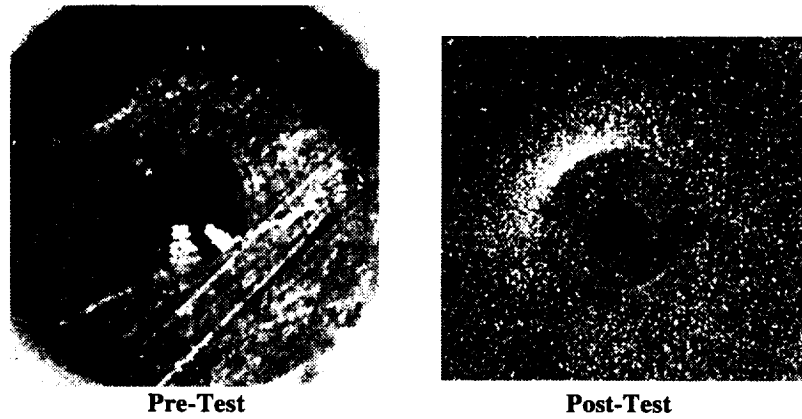

Fig. 9 HCA-006 pre- and post-test cathode orifice plate (downstream side).

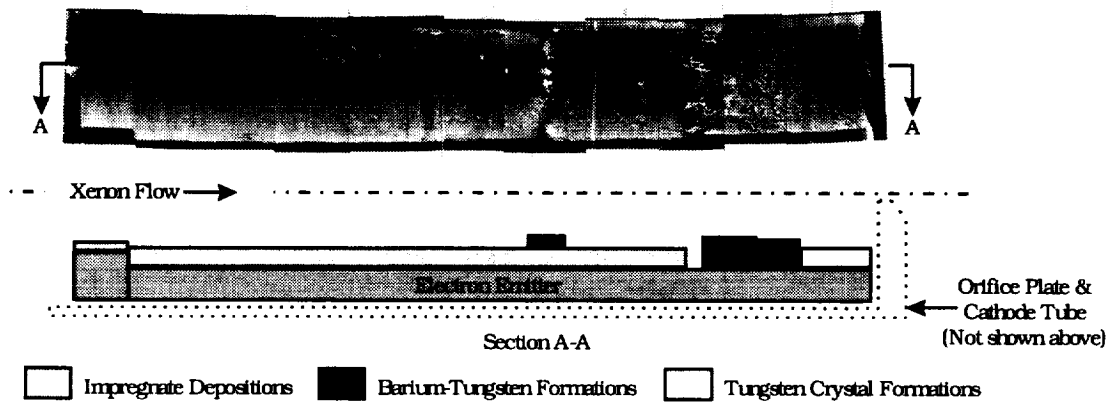

Fig. 10 HCA-006 post-test cathode electron emitter: photograph and cross-sectional schematic.

REPORT DOCUMENTATION PAGE

Form Approved
OMB No. 0704-0188

Public reporting burden for this collection of information is estimated to average 1 hour per response, including the time for reviewing instructions, searching existing data sources, gathering and maintaining the data needed, and completing and reviewing the collection of information. Send comments regarding this burden estimate or any other aspect of this collection of information, including suggestions for reducing this burden, to Washington Headquarters Services, Directorate for Information Operations and Reports, 1215 Jefferson Davis Highway, Suite 1204, Arlington, VA 22202-4302, and to the Office of Management and Budget, Paperwork Reduction Project (0704-0188), Washington, DC 20503.

1. AGENCY USE ONLY (Leave blank)		2. REPORT DATE November 1997	3. REPORT TYPE AND DATES COVERED Final Contractor Report	
4. TITLE AND SUBTITLE International Space Station Cathode Life Testing			5. FUNDING NUMBERS WU-477-72-10-00 NAS3-27186	
6. AUTHOR(S) George C. Soulas and Timothy R. Sarver-Verhey				
7. PERFORMING ORGANIZATION NAME(S) AND ADDRESS(ES) NYMA, Inc. 2001 Aerospace Parkway Brook Park, Ohio 44142			8. PERFORMING ORGANIZATION REPORT NUMBER E-10967	
9. SPONSORING/MONITORING AGENCY NAME(S) AND ADDRESS(ES) National Aeronautics and Space Administration Lewis Research Center Cleveland, Ohio 44135-3191			10. SPONSORING/MONITORING AGENCY REPORT NUMBER NASA CR-97-206230 IEPC 97-166	
11. SUPPLEMENTARY NOTES Prepared for the 25th International Electric Propulsion Conference sponsored by the Electric Propulsion Society, Cleveland, Ohio, August 24-28, 1997. Project Manager, Mike Patterson, Power & On-Board Propulsion Technologies Division, NASA Lewis Research Center, organization code 5430, (216) 977-7481.				
12a. DISTRIBUTION/AVAILABILITY STATEMENT Unclassified - Unlimited Subject Categories: 20 and 18 This publication is available from the NASA Center for AeroSpace Information, (301) 621-0390.			12b. DISTRIBUTION CODE Distribution: Nonstandard	
13. ABSTRACT (Maximum 200 words) Four hollow cathode assembly (HCA) life tests were initiated at operating conditions simulating on-orbit operation of the International Space Station plasma contactor. The objective of these tests is to demonstrate the mission-required 18,000 hour lifetime with high-fidelity development model HCAs. HCAs are operated with a continuous 6 sccm xenon flow rate and 3 A anode current. On-orbit emission current requirements are simulated with a square waveform consisting of 50 minutes at a 2.5 A emission current and 40 minutes with no emission current. One HCA test was terminated after approximately 8,000 hours so that a destructive analysis could be performed. The analysis revealed no life-limiting processes and the ultimate lifetime was projected to be greater than the mission requirement. Testing continues for the remaining three HCAs which have accumulated approximately 8,000 hours, 10,000 hours, and 11,000 hours, respectively, as of June 1997. Anode and bias voltages, strong indicators of cathode electron emitter condition, are within acceptable ranges and have exhibited no life- or performance-limiting phenomena to date.				
14. SUBJECT TERMS Hollow cathode; Hollow cathode assembly; Plasma contactor; Neutralizer; Ion thruster; Hall thruster			15. NUMBER OF PAGES 14	
			16. PRICE CODE A03	
17. SECURITY CLASSIFICATION OF REPORT Unclassified	18. SECURITY CLASSIFICATION OF THIS PAGE Unclassified	19. SECURITY CLASSIFICATION OF ABSTRACT Unclassified	20. LIMITATION OF ABSTRACT	