

NASA/TM-97-206272

1N-15  
045 667

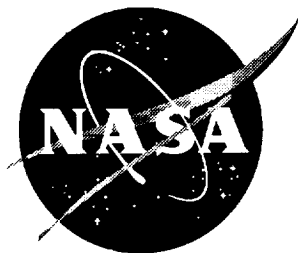

# International Space Station (ISS) Accommodation of a Single U.S. Assured Crew Return Vehicle (ACRV)

*Daniel D. Mazanek, Michelle A. Garn, and Patrick A. Troutman  
Langley Research Center, Hampton, VA*

*Yuan Wang, Renjith R. Kumar, and Michael L. Heck  
Analytical Mechanics Associates, Inc., Hampton, VA*

---

December 1997

## *The NASA STI Program Office ... in Profile*

Since its founding, NASA has been dedicated to the advancement of aeronautics and space science. The NASA Scientific and Technical Information (STI) Program Office plays a key part in helping NASA maintain this important role.

The NASA STI Program Office is operated by Langley Research Center, the lead center for NASA's scientific and technical information. The NASA STI Program Office provides access to the NASA STI Database, the largest collection of aeronautical and space science STI in the world. The Program Office is also NASA's institutional mechanism for disseminating the results of its research and development activities. These results are published by NASA in the NASA STI Report Series, which includes the following report types:

- **TECHNICAL PUBLICATION.** Reports of completed research or a major significant phase of research that present the results of NASA programs and include extensive data or theoretical analysis. Includes compilations of significant scientific and technical data and information deemed to be of continuing reference value. NASA counter-part of peer reviewed formal professional papers, but having less stringent limitations on manuscript length and extent of graphic presentations.
- **TECHNICAL MEMORANDUM.** Scientific and technical findings that are preliminary or of specialized interest, e.g., quick release reports, working papers, and bibliographies that contain minimal annotation. Does not contain extensive analysis.
- **CONTRACTOR REPORT.** Scientific and technical findings by NASA-sponsored contractors and grantees.

- **CONFERENCE PUBLICATION.** Collected papers from scientific and technical conferences, symposia, seminars, or other meetings sponsored or co-sponsored by NASA.
- **SPECIAL PUBLICATION.** Scientific, technical, or historical information from NASA programs, projects, and missions, often concerned with subjects having substantial public interest.
- **TECHNICAL TRANSLATION.** English-language translations of foreign scientific and technical material pertinent to NASA's mission.

Specialized services that help round out the STI Program Office's diverse offerings include creating custom thesauri, building customized databases, organizing and publishing research results ... even providing videos.

For more information about the NASA STI Program Office, see the following:

- Access the NASA STI Program Home Page at <http://www.sti.nasa.gov>
- E-mail your question via the Internet to [help@sti.nasa.gov](mailto:help@sti.nasa.gov)
- Fax your question to the NASA Access Help Desk at (301) 621-0134
- Phone the NASA Access Help Desk at (301) 621-0390
- Write to:  
NASA Access Help Desk  
NASA Center for AeroSpace Information  
800 Elkridge Landing Road  
Linthicum Heights, MD 21090-2934

NASA/TM-97-206272

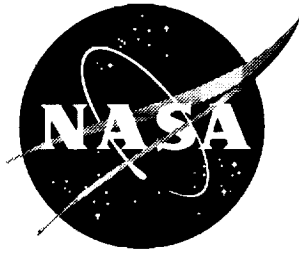

# International Space Station (ISS) Accommodation of a Single U.S. Assured Crew Return Vehicle (ACRV)

*Daniel D. Mazanek, Michelle A. Garn, and Patrick A. Troutman  
Langley Research Center, Hampton, VA*

*Yuan Wang, Renjith R. Kumar, and Michael L. Heck  
Analytical Mechanics Associates, Inc., Hampton, VA*

National Aeronautics and  
Space Administration

Langley Research Center  
Hampton, Virginia 23681-2199

---

December 1997

---

Available from the following:

NASA Center for Aerospace Information (CASI)  
800 Elkridge Landing Road  
Linthicum Heights, MD 21090-2934  
(301) 621-0390

National Technical Information Service (NTIS)  
5285 Port Royal Road  
Springfield, VA 22161-2171  
(703) 487-4650

## **Executive Summary**

The following report was generated to give the International Space Station (ISS) Program some additional insight into the operations and issues associated with accommodating a single U.S. developed Assured Crew Return Vehicle (ACRV). During the generation of this report, changes in both the ISS and ACRV programs were factored into the analysis with the realization that most of the work performed will eventually need to be repeated once the two programs become more integrated. No significant issues associated with the ISS accommodating the ACRV were uncovered. Kinematic analysis of ACRV installation showed that there are viable methods of using Shuttle and Station robotic manipulators. Separation analysis demonstrated that the ACRV departure path clears the Station structure for all likely contingency scenarios. The payload bay packaging analysis identified trades that can be made between payload bay location, Shuttle Remote Manipulator System (SRMS) reach and eventual designs of de-orbit stages and docking adapters.

# Table of Contents

1.0 Introduction .....	1
2.0 Background .....	1
3.0 Configuration Assessment .....	1
3.1 ISS Configuration .....	1
3.2 ACRV Configuration .....	3
4.0 Assumptions and Requirements .....	3
4.1 Single ACRV .....	3
4.2 Delivery of ACRV .....	4
4.3 Berthing or Docking .....	4
4.4 Attach Mechanism Location on the ACRV .....	4
4.5 Contingency Orbiter Docking Port .....	4
4.6 Utility Connections .....	4
4.7 Fluids .....	5
4.8 ACRV Power during Berthing Operations .....	5
4.9 Concurrent Orbiter and ACRV Operations .....	5
4.10 Unpowered Station .....	5
4.11 Initial Separation $\Delta V$ .....	5
5.0 Kinematic Assessment of ACRV Installation and Swap-Out .....	5
5.1 Installation Assumptions and Motion Constraints .....	5
5.2 ACRV Manifest Location and Berthing Interface .....	6
5.2.1 ACRV Attachment and Berthing Interface .....	6
5.2.2 ACRV Manifest Location within the Orbiter Payload Bay .....	6
5.2.3 Orbiter C.G. Determination .....	8
5.3 Grapple Fixture Locations .....	10
5.4 Installation Scenario .....	11
5.5 Swap-Out Scenario .....	17
6.0 ACRV Separation Trajectory Analysis .....	21
6.1 Analysis Assumptions .....	21
6.1.1 ISS Operating Conditions .....	21
6.1.2 ACRV Separation Configuration .....	23
6.1.3 ACRV Initial Separation Velocity .....	23
6.2 Separation Analysis Results .....	23
6.2.1 In-Plane and Out-of-Plane Motion Results .....	26
6.2.2 ISS/ACRV Minimum Distance Results .....	
35	
7.0 Assessment of ACRV Impacts on ISS .....	41
7.1 ISS Control Analysis .....	41
7.2 ISS Microgravity Analysis .....	43
7.3 ISS Resource Utilities .....	43
8.0 Conclusions/Summary .....	44
9.0 References .....	45

## List of Figures and Tables

Figure 3.1-1:	ISS Configuration Top View .....	2
Figure 3.1-2:	ISS Configuration Side View .....	2
Figure 3.2-1:	ACRV Configuration .....	3
Figure 5.2.2-1:	Aft ACRV Position in the Orbiter Payload Bay .....	7
Figure 5.2.2-2:	Forward ACRV Position in the Orbiter Payload Bay .....	8
Figure 5.2.3-1:	ACRV and Orbiter Composite C.G. Locations for ACRV Aft Position .....	9
Figure 5.2.3-2:	ACRV and Orbiter Composite C.G. Locations for ACRV Forward Position .....	9
Figure 5.3-1:	ACRV Grapple Fixture Locations .....	10
Figure 5.4-1:	SSRMS Grapples ACRV in Orbiter Bay using the FRGF Located on the Modified PMA .....	11
Figure 5.4-2:	SSRMS Installs the ACRV on the U.S. Habitation Module .....	12
Figure 5.4-3:	SSRMS Grapples the ACRV on the Port Side FRGF on the Modified PMA .....	13
Figure 5.4-4:	SSRMS Installs ACRV using the Port Side FRGF on the Transition Section .....	14
Figure 5.4-5:	SRMS Grapples the ACRV in the Orbiter Bay .....	15
Figure 5.4-6:	SRMS Hands the ACRV to the SSRMS using the Aft FRGFs .....	16
Figure 5.5-1:	SSRMS Hands the ACRV to the SSRMS .....	17
Figure 5.5-2:	SSRMS Grapples the Replacement ACRV in the Orbiter Bay while the SRMS Holds the Original ACRV .....	18
Figure 5.5-3:	SSRMS Installs the Replacement ACRV on the ISSA .....	19
Figure 5.5-4:	SRMS Places the Original ACRV in the Orbiter Bay .....	20
Figure 6.1.1-1:	ISS "Free Drift" Attitude History (No Angular Rate Offsets) .....	22
Figure 6.1.1-2:	ISS "Free Drift" Attitude Rates (No Angular Rate Offsets) .....	22
Table 6.2-1:	Separation Results Summary Chart for ACRV $\Delta V = 0.05$ m/s .....	24
Table 6.2-2:	Separation Results Summary Chart for ACRV $\Delta V = 0.10$ m/s .....	24
Table 6.2-3:	Separation Results Summary Chart for ACRV $\Delta V = 0.20$ m/s .....	25
Figure 6.2.1-1:	In-Plane Motion for No ISS Angular Rate Offsets .....	28
Figure 6.2.1-2:	Out-of-Plane Motion for No ISS Angular Rate Offsets .....	28
Figure 6.2.1-3:	In-Plane Motion for ISS $\omega_x = -0.65$ deg/s .....	29
Figure 6.2.1-4:	Out-of-Plane Motion for ISS $\omega_x = -0.65$ deg/s .....	29
Figure 6.2.1-5:	In-Plane Motion for ISS $\omega_x = +0.65$ deg/s .....	30
Figure 6.2.1-6:	Out-of-Plane Motion for ISS $\omega_x = +0.65$ deg/s .....	30
Figure 6.2.1-7:	In-Plane Motion for ISS $\omega_y = -0.65$ deg/s .....	31
Figure 6.2.1-8:	Out-of-Plane Motion for ISS $\omega_y = -0.65$ deg/s.....	31
Figure 6.2.1-9:	In-Plane Motion for ISS $\omega_y = +0.65$ deg/s .....	32
Figure 6.2.1-10:	Out-of-Plane Motion for ISS $\omega_y = +0.65$ deg/s .....	32
Figure 6.2.1-11:	In-Plane Motion for ISS $\omega_z = -0.65$ deg/s .....	33
Figure 6.2.1-12:	Out-of-Plane Motion for ISS $\omega_z = -0.65$ deg/s .....	33
Figure 6.2.1-13:	In-Plane Motion for ISS $\omega_z +0.65$ deg/s .....	34

Figure 6.2.1-14: Out-of-Plane Motion for ISS $\omega_z = +0.65$ deg/s .....	34
Figure 6.2.2-1: Minimum Distance Between ACRV and ISS ISS $\omega_x = +/-0.65$ deg/s and ACRV $\Delta V = 0.05$ m/s .....	37
Figure 6.2.2-2: Minimum Distance Between ACRV and ISS ISS $\omega_x = +/-0.65$ deg/s and ACRV $\Delta V = 0.10$ m/s .....	37
Figure 6.2.2-3: Minimum Distance Between ACRV and ISS ISS $\omega_x = +/-0.65$ deg/s and ACRV $\Delta V = 0.20$ m/s.....	38
Figure 6.2.2-4: Minimum Distance Between ACRV and ISS ISS $\omega_y = +/-0.65$ deg/s and ACRV $\Delta V = 0.05$ m/s .....	38
Figure 6.2.2-5: Minimum Distance Between ACRV and ISS ISS $\omega_y = +/-0.65$ deg/s and ACRV $\Delta V = 0.10$ m/s .....	39
Figure 6.2.2-6: Minimum Distance Between ACRV and ISS ISS $\omega_y = +/-0.65$ deg/s and ACRV $\Delta V = 0.20$ m/ .....	39
Figure 6.2.2-7: Minimum Distance Between ACRV and ISS ISS $\omega_z = +/-0.65$ deg/s and ACRV $\Delta V = 0.05$ m/s .....	40
Figure 6.2.2-8: Minimum Distance Between ACRV and ISS ISS $\omega_z = +/-0.65$ deg/s and ACRV $\Delta V = 0.10$ m/s .....	40
Figure 6.2.2-9: Minimum Distance Between ACRV and ISS ISS $\omega_z = +/-0.65$ deg/s and ACRV $\Delta V = 0.20$ m/s .....	41
Figure 7.1-1: ISS with ACRV Attached-Nominal Operations Attitude History .....	42
Figure 7.1-2: ISS with ACRV Attached - Nominal Operations Attitude Rates .....	42
Figure 7.2-1: ACRV Impact on ISS One Microgravity Region .....	43



## **List of Acronyms**

<b>ACRV</b>	<b>Assured Crew Return Vehicle</b>
<b>ADASS</b>	<b>Articular Dynamic Analysis of Spacecraft Systems</b>
<b>BC</b>	<b>Ballistic Coefficient</b>
<b>CMG</b>	<b>Control Moment Gyro</b>
<b>DOF</b>	<b>Degree-of-Freedom</b>
<b>ESA</b>	<b>European Space Agency</b>
<b>ERA</b>	<b>ESA Robotic Arm</b>
<b>FRGF</b>	<b>Flight Release Grapple Fixture</b>
<b>GN<sub>2</sub></b>	<b>Gaseous Nitrogen</b>
<b>HAB</b>	<b>U.S. Habitation Module</b>
<b>IP</b>	<b>In-Plane</b>
<b>ISS</b>	<b>International Space Station</b>
<b>LVLH</b>	<b>Local Vertical - Local Horizontal</b>
<b>OOP</b>	<b>Out-of-Plane</b>
<b>PDGF</b>	<b>Power Data Grapple Fixture</b>
<b>PMA</b>	<b>Pressurized Mating Adapter</b>
<b>RCS</b>	<b>Reaction Control System</b>
<b>SRMS</b>	<b>Shuttle Remote Manipulator System</b>
<b>SSRMS</b>	<b>Space Station Remote Manipulator System</b>
<b>TEA</b>	<b>Torque Equilibrium Attitude</b>
<b>TTC</b>	<b>Time To Clear</b>



## **1.0 Introduction**

The purpose of this study was to update and expand upon a previous study performed in November 1995, detailing where and how an Assured Crew Return Vehicle (ACRV) would interface with the International Space Station (ISS). The final report resulting from the previous study was entitled "International Space Station/Crew Return Vehicle Interface Final Report" (Ref. 1). Subsequent to Ref. 1, several changes have occurred which affect the accommodation of an ACRV on the ISS. These changes include significant modifications to the Russian hardware attached to the ISS, as well as the baseline program adopting the accommodation of a single U.S. ACRV. In addition, the ACRV configuration geometry has been modified to allow for the return of all six crew members using a single ACRV. Previously, the ACRV allowed for the return of only four crew members, and therefore two ACRVs were required to be attached to the ISS. Ref. 1 extensively describes various attachment locations, scenarios, and physical interfaces associated with accommodating multiple ACRVs on the ISS. This study focuses on accommodating a single ACRV solely on the U.S. side of the space station. Based on the above changes, the two main objectives of this study were to provide a kinematic assessment of the installation and swap-out of the updated ACRV, and assess the separation characteristics of the ACRV for an uncontrolled ISS with worst case angular rates, as well as a "free drift" reference case. A single accommodation location was assumed for this study, with the ACRV attached to a modified Pressurized Mating Adapter (PMA) located on the nadir end of the U.S. Habitation module (HAB).

## **2.0 Background**

The primary mission of the ACRV is to bring ISS personnel back to the Earth in case of illness, injury or other contingency requiring evacuation of the space station vehicle. The ACRV must be easily accessible to the ISS crew and allow for the timely separation of the ACRV from the station in case of an emergency. The proposed on-orbit stay time for the ACRV is as long as one year, and therefore the ACRV and ISS both must be able to accommodate this kind of extended connection.

## **3.0 Configuration Assessment**

The ISS configuration studied in this analysis was Assembly Complete (Stage-41 1E) as described in Ref. 2. This is the final stage of the baseline assembly sequence and the point at which the current ISS assembly sequence is complete. It is at this point that the ACRV is required to be fully operational to support ISS contingency operations.

### **3.1 ISS Configuration**

Figures 3.1-1 and 3.1-2 show top and sides views, respectively, of the ISS Assembly Complete configuration assumed for the kinematic and separation analysis performed in this study. Figure 3.1-2 shows the attached location of the ACRV on the nadir end of the U.S. HAB module. Note that the two figures are not shown to the same scale.

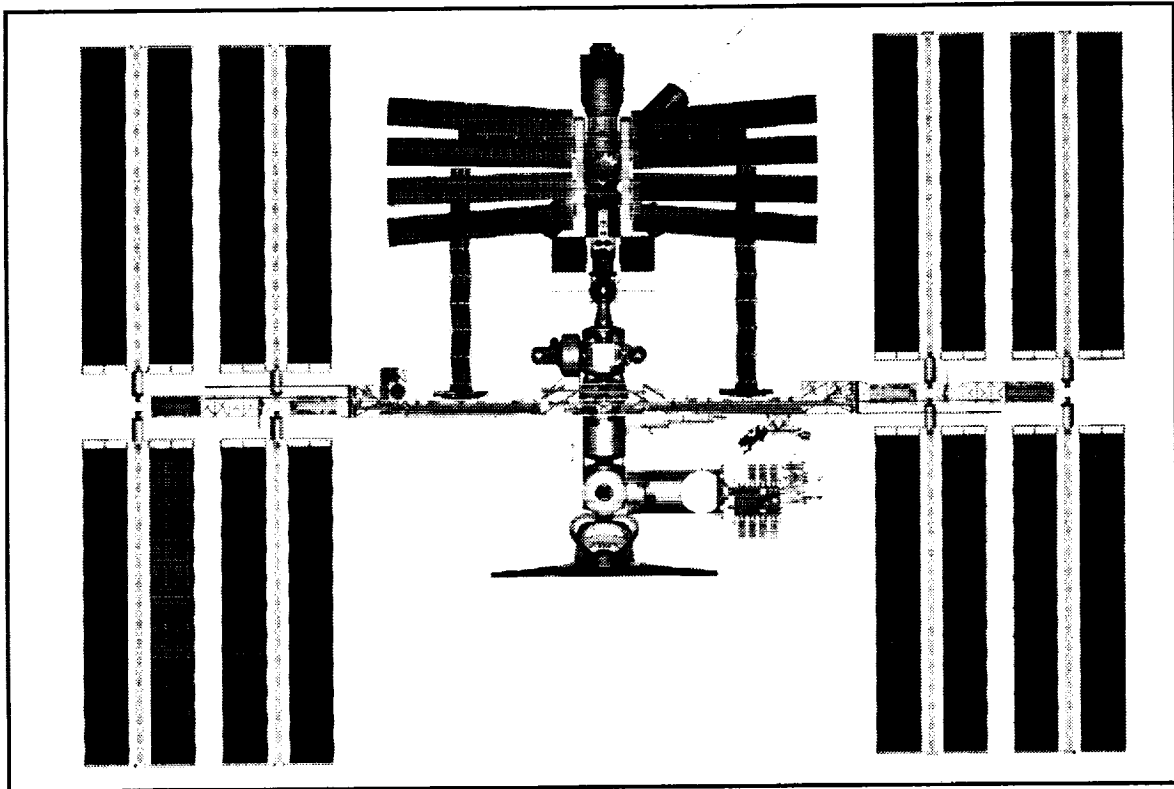

Figure 3.1-1: ISS Configuration Top View

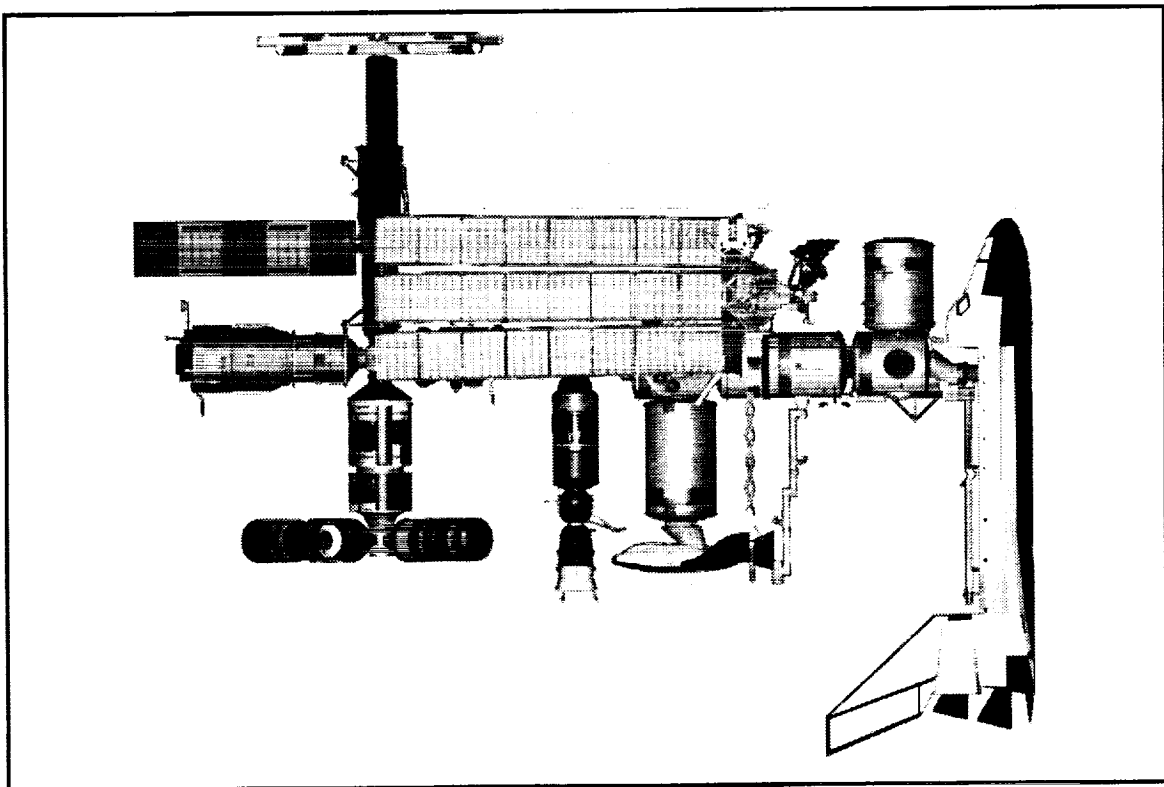

Figure 3.1-2: ISS Configuration Side View

### 3.2 ACRV Configuration

Figure 3.2-1 depicts the ACRV configuration and the masses assumed for this study. The centerline of the ACRV hatch is located at ACRV station 210 inches, which is 204.05 inches aft of the spacecraft's nose.

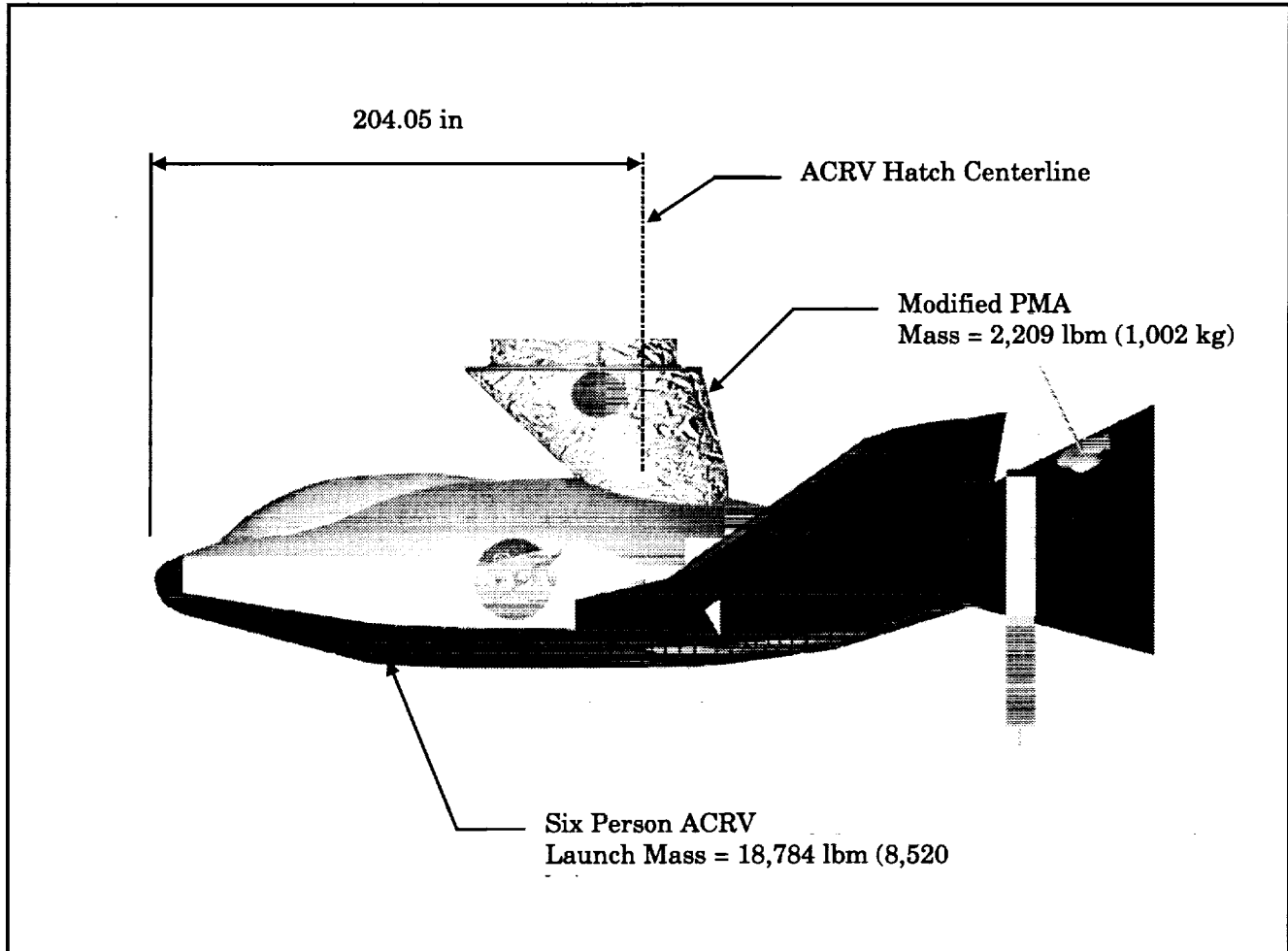

Figure 3.2-1: ACRV Configuration

### 4.0 Assumptions and Requirements

The following assumptions and requirements were primarily derived from Ref. 1 and have been repeated here to provide a complete outline of the assumptions and requirements that drive the ISS accommodation of the ACRV.

#### 4.1 Single ACRV

A single six person U.S. ACRV configuration was assumed for this study along with a single Russian Soyuz Module, which is the current NASA requirement for the space

station. This allows the U.S. ACRV to return the entire six person ISS crew in the event of a major systems failure, which might occur between Space Shuttle Orbiter visits.

#### **4.2 Delivery of ACRV**

The U.S. ACRV is transferred to the orbiting ISS using the Space Shuttle Orbiter.

#### **4.3 Berthing or Docking**

Since the ACRV is brought up by another vehicle, and this vehicle either attaches directly to the station, or hovers in close proximity, it is assumed that the robotic arms are used to remove the ACRV from its carrier vehicle. Since the robotic arms are incapable of providing the required force for docking, the ACRV is berthed, with a robotic arm, to its attach location. There are three robotic arms available to perform this function, depending on the scenario. These are the Shuttle Remote Manipulator System (SRMS), the Space Station Remote Manipulator System (SSRMS) and the European Space Agency (ESA) Robotic Arm (ERA). Only the SRMS and SSRMS were assumed for this analysis. The type of grapple fixtures used for these operations is assumed to be a standard Flight Releasable Grapple Fixture (FRGF).

#### **4.4 Attach Mechanism Location on the ACRV**

The attach mechanism for the ACRV is assumed to be on top of the fuselage, not in the nose of the vehicle. Because of the shape of the vehicle and its required aerodynamic properties for return through the atmosphere, it is impractical to locate the attach mechanism in the nose. The size of the attach mechanism that the station uses also directly impacts the aerodynamic properties of the ACRV. These attach mechanisms are described extensively in Ref. 1.

#### **4.5 Contingency Orbiter Docking Port**

There are two locations on the current space station configuration where the Orbiter can dock. The primary location is on the front of the U.S. Laboratory Module on Node 2 and is designated PMA2 (Pressurized Mating Adapter). The contingency docking location is on the nadir port of the U.S. Habitation module and is designated PMA3. In the current Space Shuttle Program philosophy, it is required to have a contingency orbiter docking location. However, this is the only possible location on the U.S. provided elements for the six person ACRV, and is the attach location assumed in this study. Given that the docking mechanism on the station is passive (has no active components) it is considered unlikely that a failure of the primary port will cause the need for the contingency port to be used. Therefore, it is not an unreasonable assumption at this point, to locate one ACRV on the nadir HAB port.

#### **4.6 Utility Connections**

The ACRV will require TBD kW of power from the station while attached. It is also assumed that the station can provide 140 cubic feet per minute of air with a drag on duct to allow the ACRV to maintain thermal control.

#### **4.7 Fluids**

If any fluids are required by ACRV, it will be on a contingency basis. The fluids required are O<sub>2</sub>, N<sub>2</sub> and H<sub>2</sub>O. These fluids would be resupplied via a carry-on canister (such as a K-bottle) or a hardline connection.

#### **4.8 ACRV Power during Berthing Operations**

Since the ACRV is assumed to be berthed using some combination of robotic arm operations, it must be able to withstand some TBD time without power. This is necessary because the type of grapple fixture assumed, the FRGF, has no capability to transfer power.

#### **4.9 Concurrent Orbiter and ACRV Operations**

It is assumed that if an Orbiter was attached to the space station, it would be utilized first for returning crew. Then, if more crew than the orbiter could carry needed to return, the ACRV would be used next. This approach precludes the possibility of the ACRV contacting an attached orbiter when released.

#### **4.10 Unpowered Station**

In the event that the station is unpowered, the ACRV must still be able to release itself from the station and return.

#### **4.11 Initial Separation $\Delta V$**

It is assumed that the attach mechanism provides the initial  $\Delta V$  when the ACRV separates. The use of the GN<sub>2</sub> RCS thruster system to provide additional  $\Delta V$  was not addressed in this study.

### **5.0 Kinematic Assessment of ACRV Installation and Swap-Out**

#### **5.1 Installation Assumptions and Motion Constraints**

As mentioned previously, the following assumptions were made for this study. The Orbiter is docked to PMA2 which is located on the front of the U.S. Laboratory module and the nadir U.S. Habitation module port is used for the ACRV installation and swap-out. A two foot minimum clearance is required between any portion of the SRMS and the orbiter or ISSA structure (defined in NSTS 07700, Volume XIV, Appendix 8). This two foot clearance envelope was also assumed for the SSRMS. It was also assumed

that the SRMS and the SSRMS must have a minimum 30 degree angle away from fully extended at the elbow joint.

## **5.2 ACRV Manifest Location and Berthing Interface**

### **5.2.1 ACRV Attachment and Berthing Interface**

The berthing interface between the ACRV and ISS is assumed to be a modified PMA, which is located on the upper surface of the ACRV. The center of the hatch is located at ACRV station X = 210 inches which locates it 204.05 inches aft of the ACRV nose as shown in Figure 3.2-1.

The PMA is shortened in order to fit within the Orbiter bay 14.5 foot dynamic clearance envelope when it is attached to the ACRV. The station robotic arm does not provide enough force to dock the ACRV to the station therefore a Common Berthing Mechanism (CBM) must actually perform the installation. The station arm moves the ACRV to within the capture envelope and then the CBM takes over and begins the latching process. The CBM is located on the modified PMA which has a Smooth Magnetic Interface (SMI) as the attachment fixture on the ACRV end. The SMI connects to the ACRV and when detached leaves a flat aerodynamic surface.

### **5.2.2 ACRV Manifest Location within the Orbiter Payload Bay**

Two Orbiter bay locations for the ACRV were compared for installation and swap-out. In the first position, the ACRV is supported in the Orbiter coordinate system in X, Y, and Z by trunnions and a keel fitting at  $X_0 = 1175.20$  inches with the nose forward in the bay and the hatch facing out of the bay (Figure 5.2.2-1).

The ACRV must be located in the Orbiter bay with the nose forward in order to meet launch load constraints. The ACRV is moved forward in the Orbiter bay 40.5 inches for the second position (Figure 5.2.2-2). This is done to provide an installation option where the SSRMS can reach a grapple fixture located on the transition section of the ACRV which will be discussed in Sections 5.4 and 5.5.

In Figures 5.2.2-1 and 5.2.2-2, the outlined box indicates the space required to accommodate a Spacehab module in the Orbiter cargo bay. Note that in the forward position a Spacehab module will not fit in the bay. In the aft position a Spacehab module will fit but the two foot clearance requirement is violated.



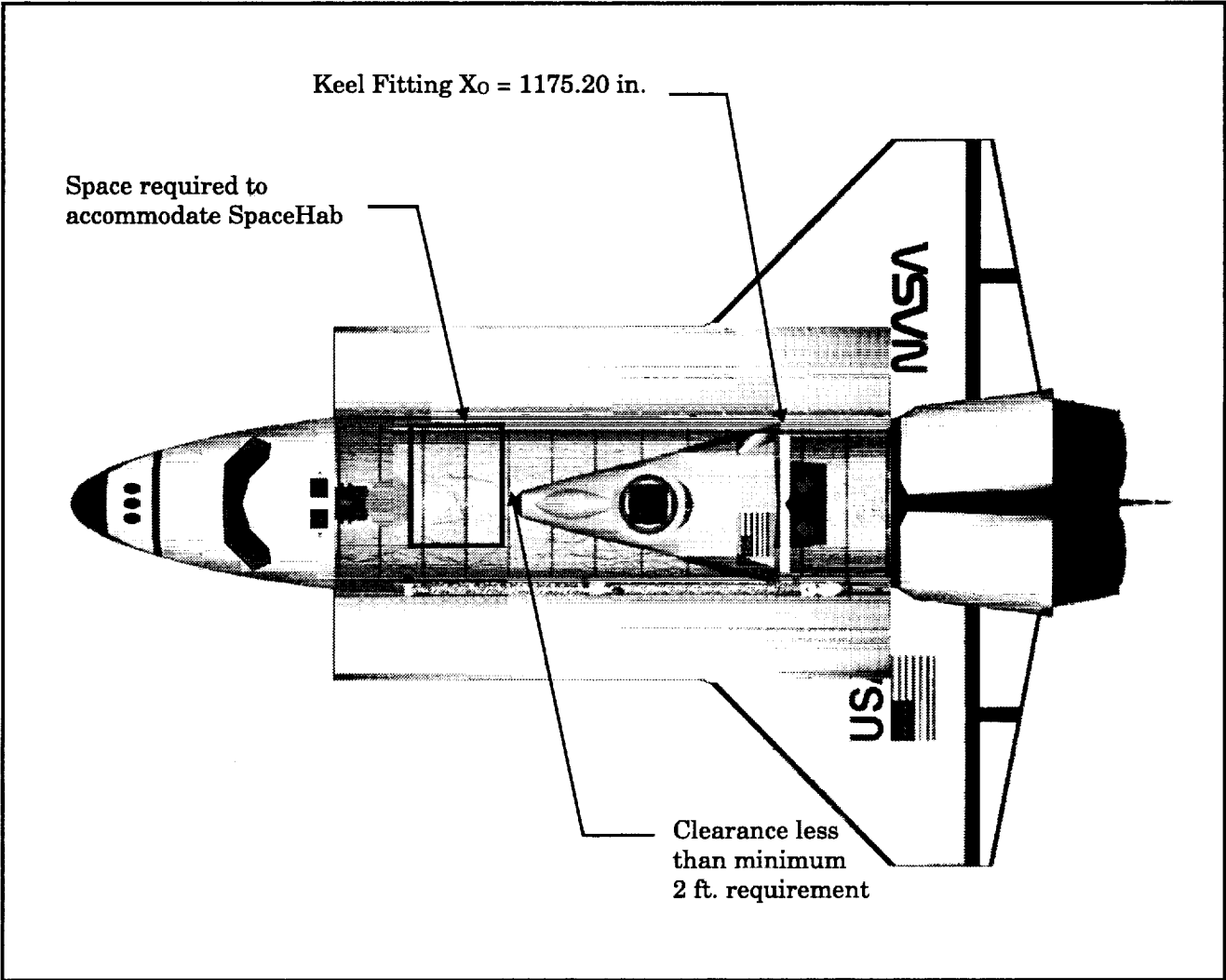

Figure 5.2.2-1: Aft ACRV Position in the Orbiter Payload Bay

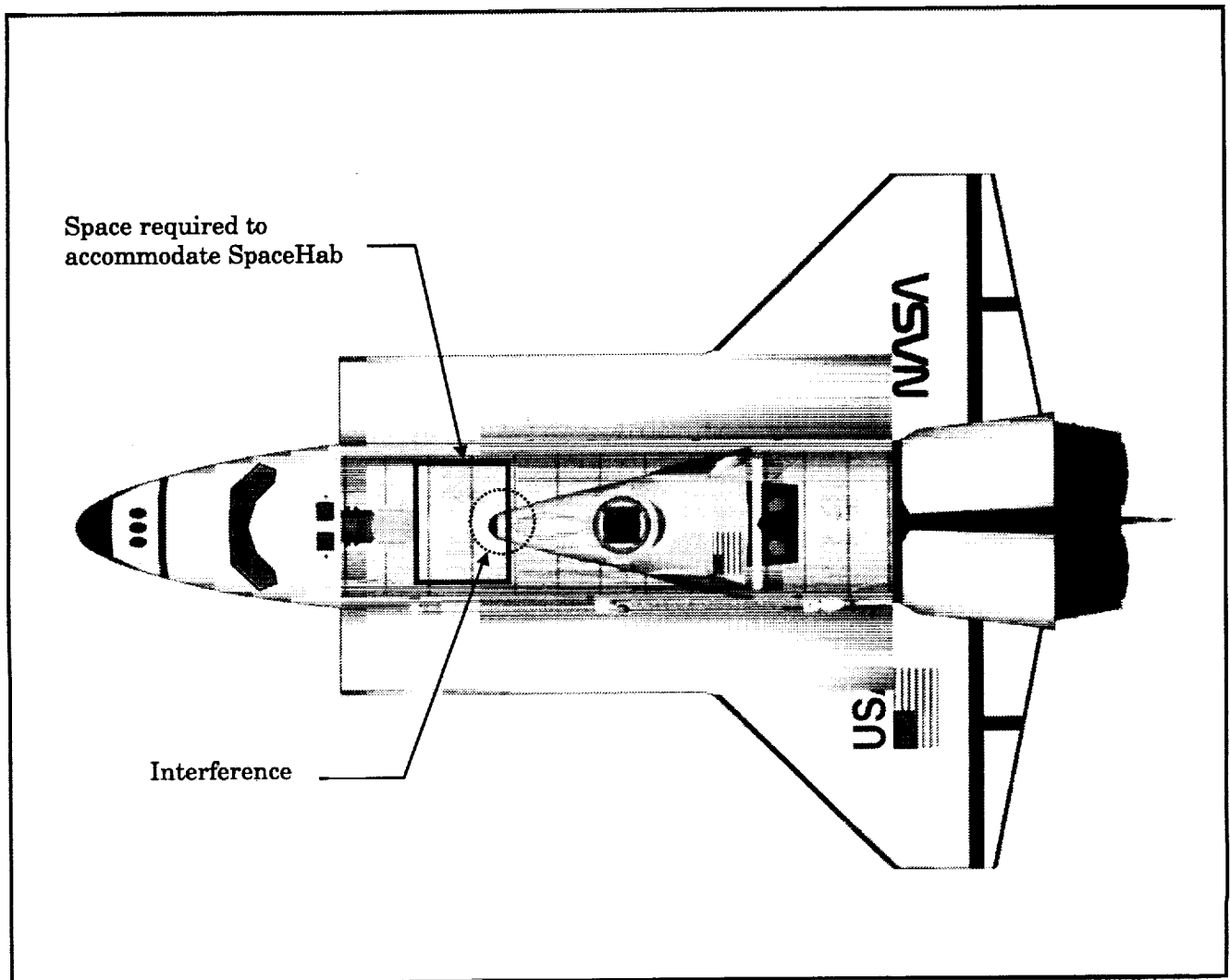

Figure 5.2.2-2: Forward ACRV Position in the Orbiter Payload Bay

### 5.2.3 Orbiter C.G. Determination

Figure 5.2.3-1 depicts the ACRV and Orbiter C.G. positions for the ACRV in the aft position required for the SSRMS to reach a grapple fixture on the transition structure. Assuming an ACRV mass of 18,784 lbm (8,520 kg) and a modified PMA mass 2,209 lbm (1,002 kg), the composite Orbiter/Cargo C.G. is located at  $X_0 = 1080.3$  inches, which is within the Orbiter C.G. limits. The mass of any required attach hardware was assumed to be 1,219 lbm (553 kg) and the C.G. was assumed to be at the same  $X$ -location as the ACRV. If the ACRV is located in the forward position (Figure 5.2.3-2), the composite C.G. is located at slightly outside of the forward No Deploy limit for the orbiter at  $X_0 = 1076.1$  inches. Since there is significant mass margin, the addition of ballast to bring the composite C.G. within the Orbiter limits should be feasible.

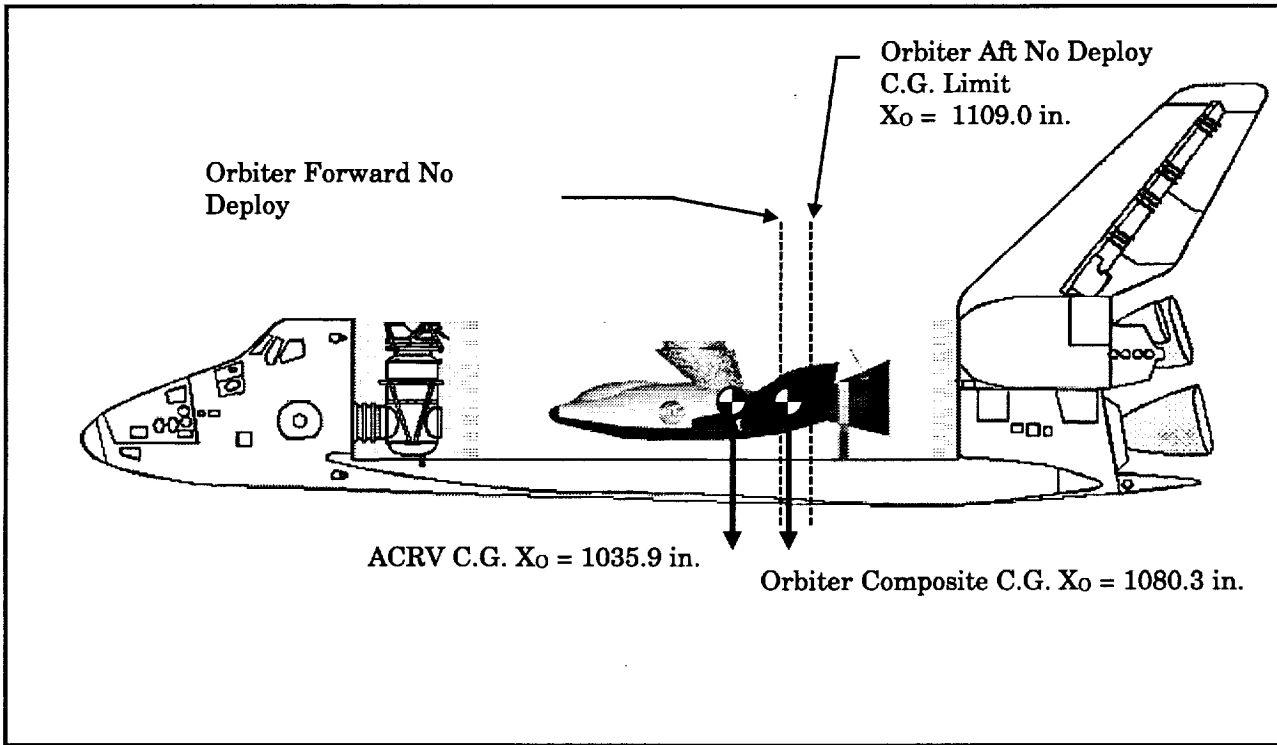

Figure 5.2.3-1: ACRV and Orbiter Composite C.G. Locations for ACRV Aft Position

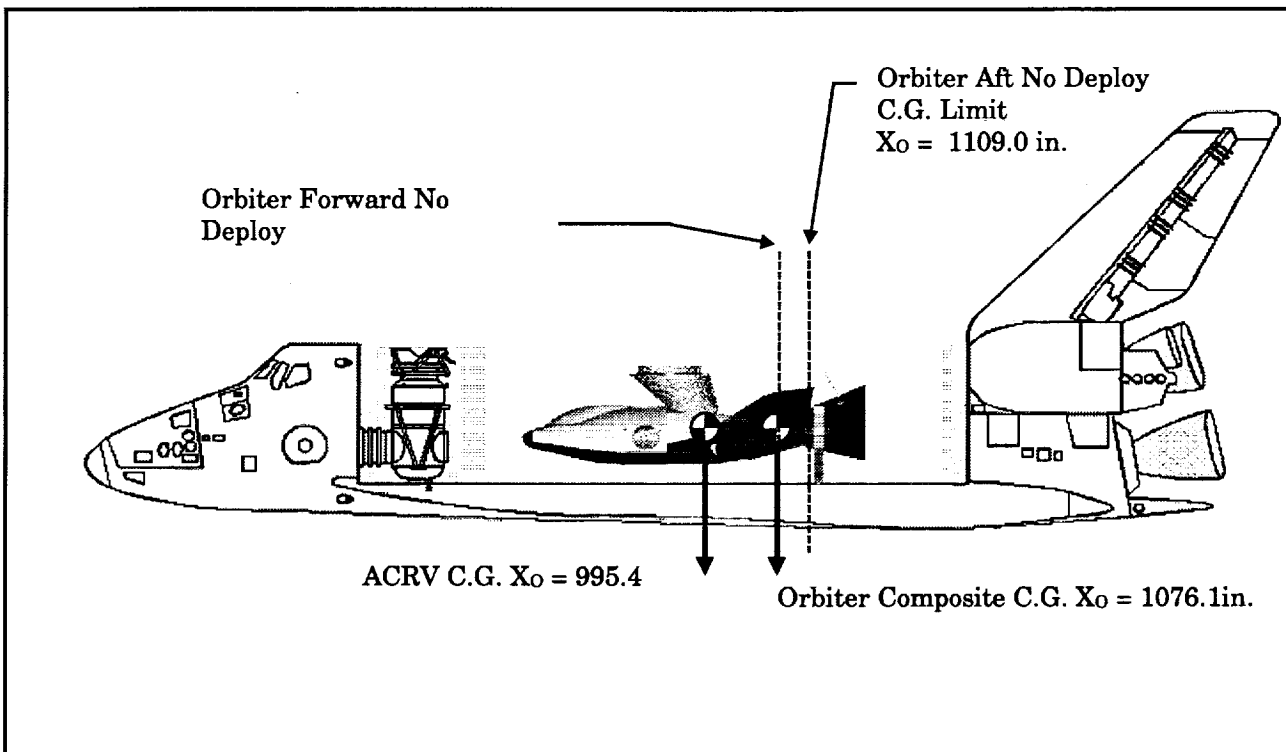

Figure 5.2.3-2: ACRV and Orbiter Composite C.G. Locations for ACRV Forward Position

### 5.3 Grapple Fixture Locations

The SSRMS and the SRMS were the two robotic arms utilized for this analysis. The station robotic arm was located on the power data grapple fixture (PDGF) on the U.S. Laboratory module for these operations. The distance from the mobile transporter to the Orbiter bay is too large to be able to use the SSRMS from the mobile transporter. Three FRGF locations on the ACRV were considered. Two of these locations are required. One FRGF is located on the modified PMA and the other two are located on the transition stage (Figure 5.3-1). The method chosen for ACRV installation and swap-out dictate which two grapple fixtures are required.

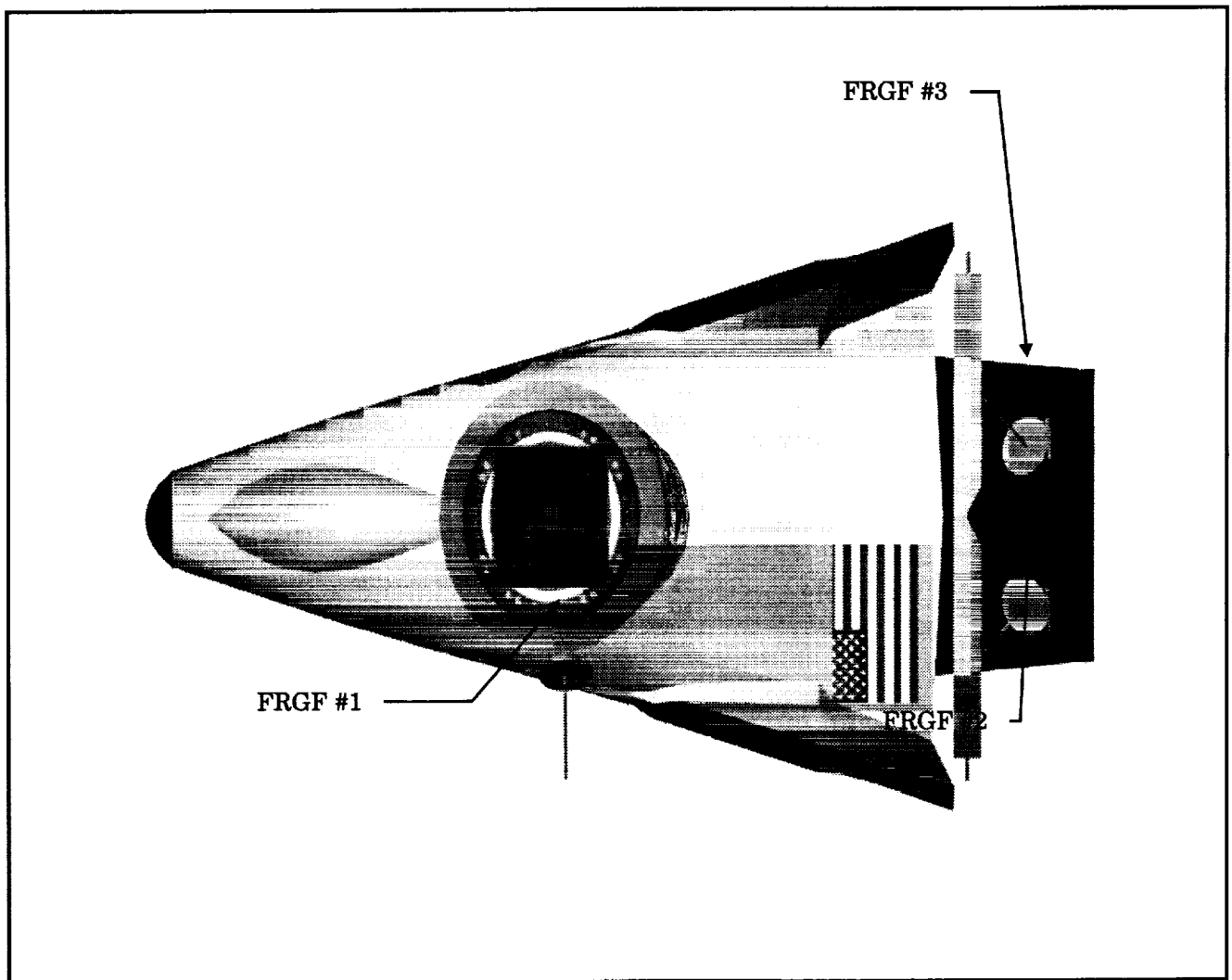

Figure 5.3-1: ACRV Grapple Fixture Locations

## 5.4 Installation Scenario

The ACRV can be installed using the SSRMS alone. When the ACRV is located in the aft position, the SSRMS grapples the FRGF located on the modified PMA as shown in Figure 5.4-1.

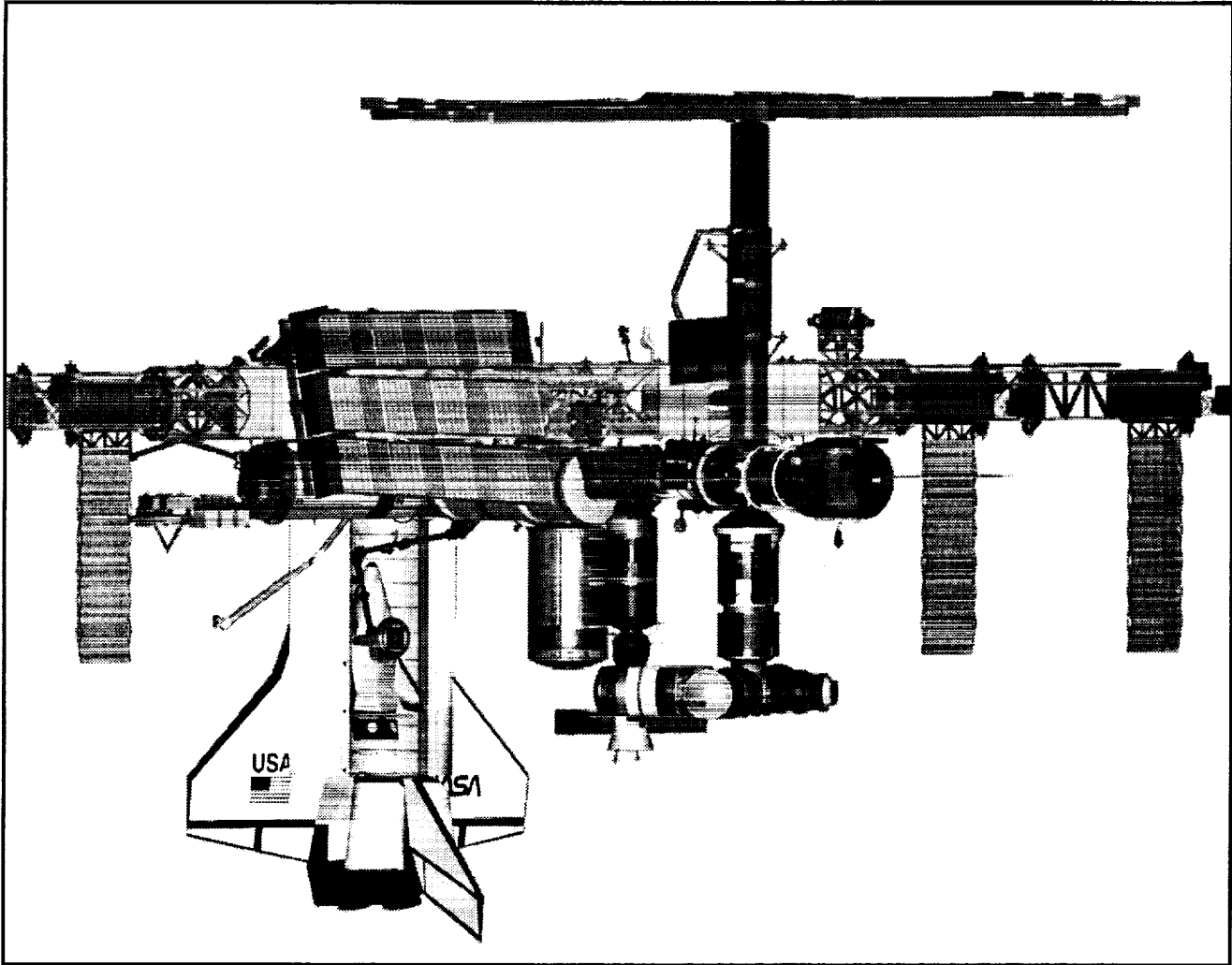

Figure 5.4-1: SSRMS Grapples ACRV in Orbiter Bay using the FRGF Located on the Modified PMA

The SRMS needs to be deployed before this operation to allow for clearance between it and the SSRMS. The SSRMS then removes the ACRV from the Orbiter bay and places it on the nadir U.S. Habitation module port (Figure 5.4-2).

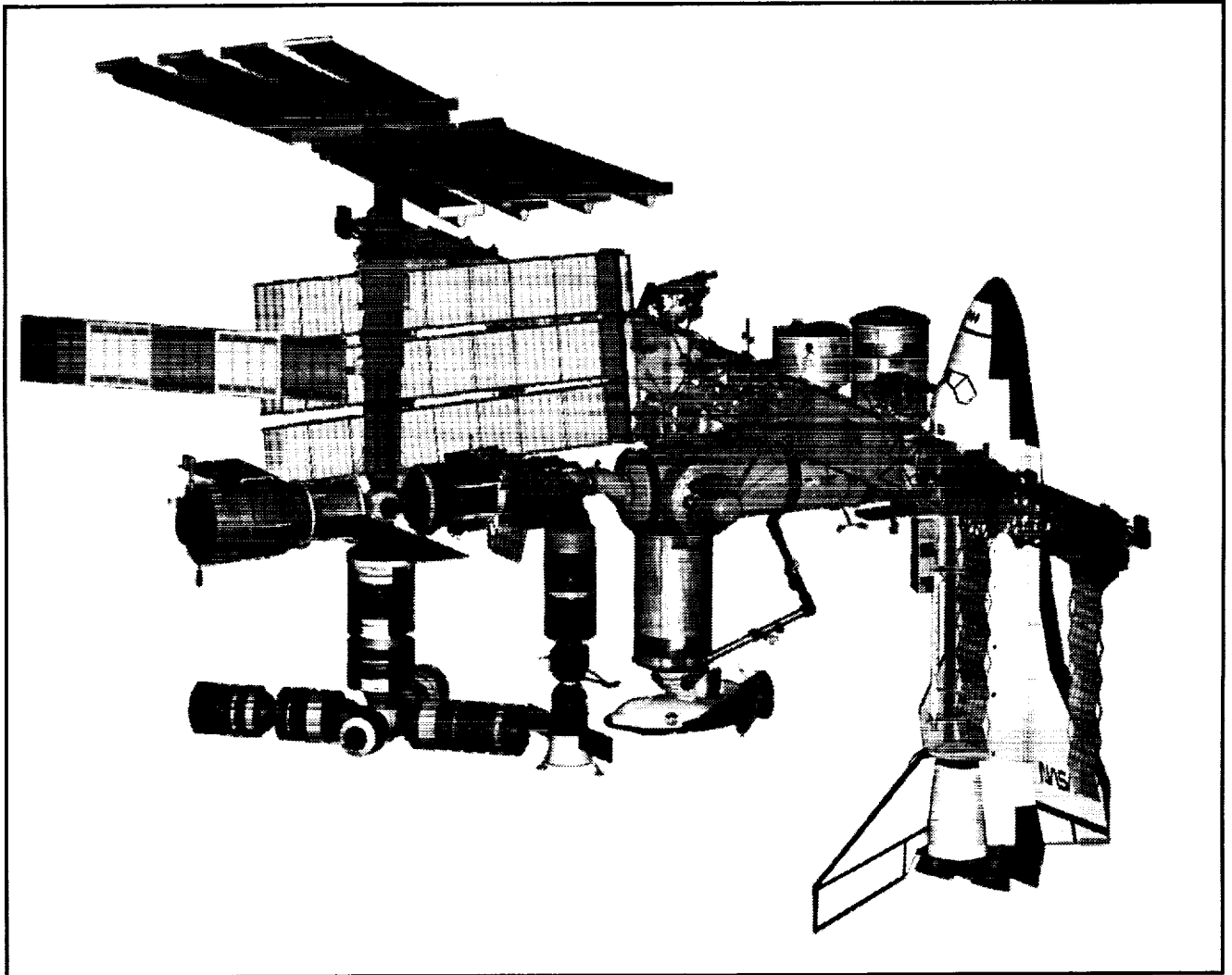

Figure 5.4-2: SSRMS Installs the ACRV on the U.S. Habitation Module

The SSRMS can not reach the two grapple fixtures located on the transition stage when the ACRV is in the aft bay location. In order for the SSRMS to reach the port side FRGF on the transition section of the ACRV, the ACRV needs to be located in the forward position discussed above (Figure 5.4-3).

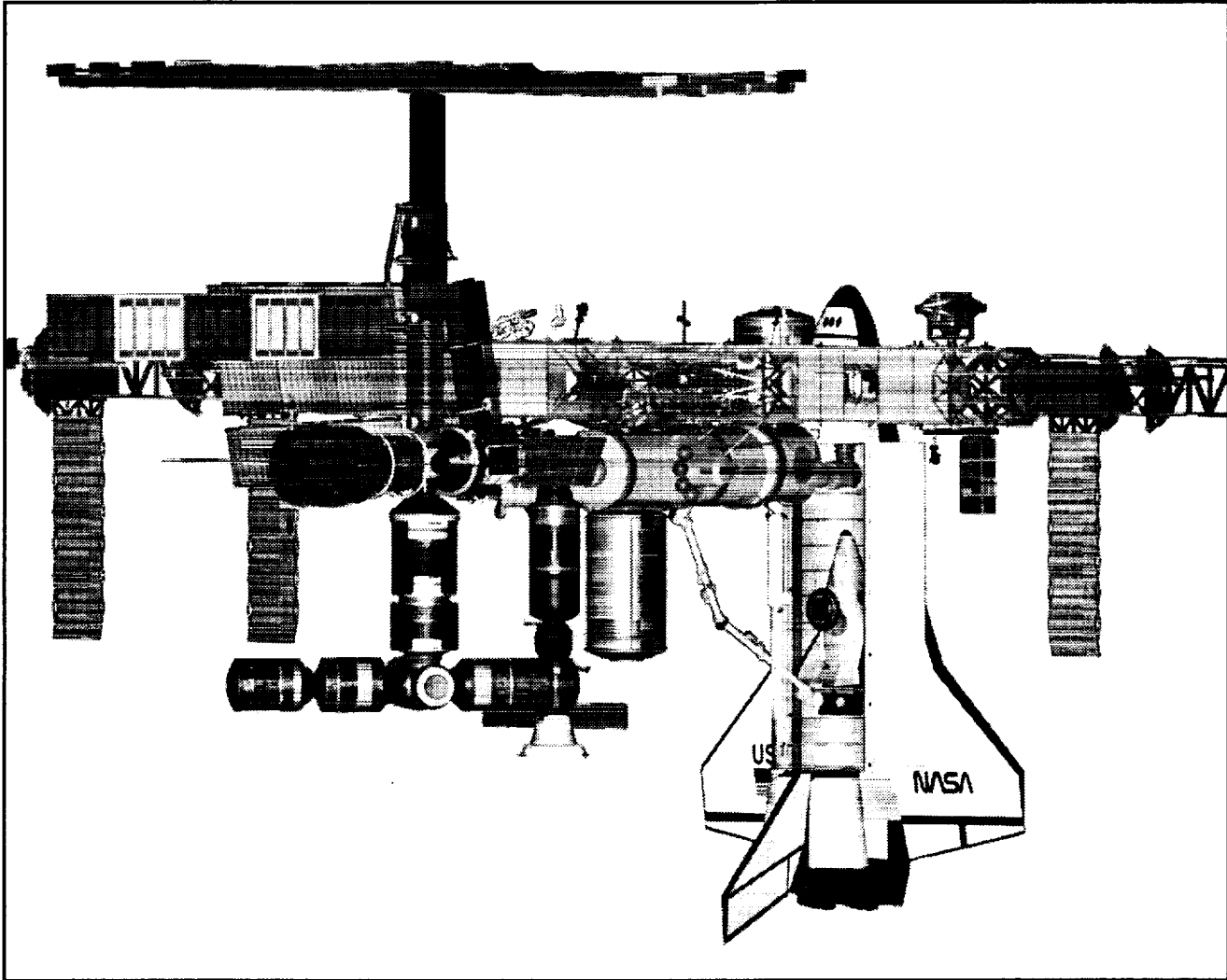

Figure 5.4-3: SSRMS Grapples the ACRV on the Port Side FRGF on the Modified PMA

The ACRV would have to be further forward in the Orbiter bay in order to reach the starboard side grapple fixture on the ACRV. The SSRMS then removes the ACRV from the payload bay and places it on the station (Figure 5.4-4).

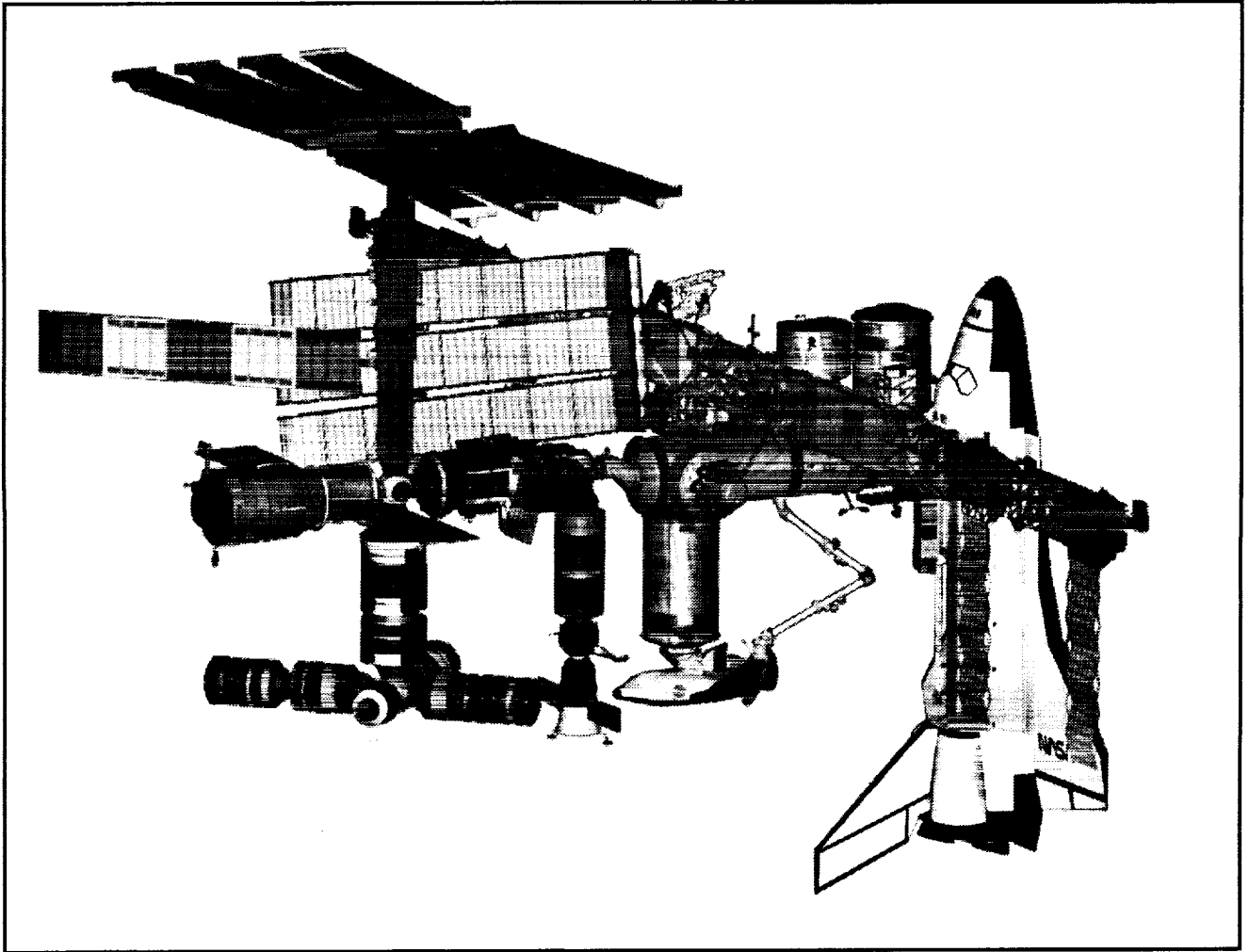

Figure 5.4-4: SSRMS Installs ACRV using the Port Side FRGF on the Transition Section



Another option would be to use the aft ACRV location, grapple the ACRV with the SRMS (Figure 5.4-5), hand the ACRV to the SSRMS (Figure 5.4-6), and then use the SSRMS to place the ACRV on the station. The SRMS can reach all three grapple fixtures on the ACRV in either the forward or aft location.

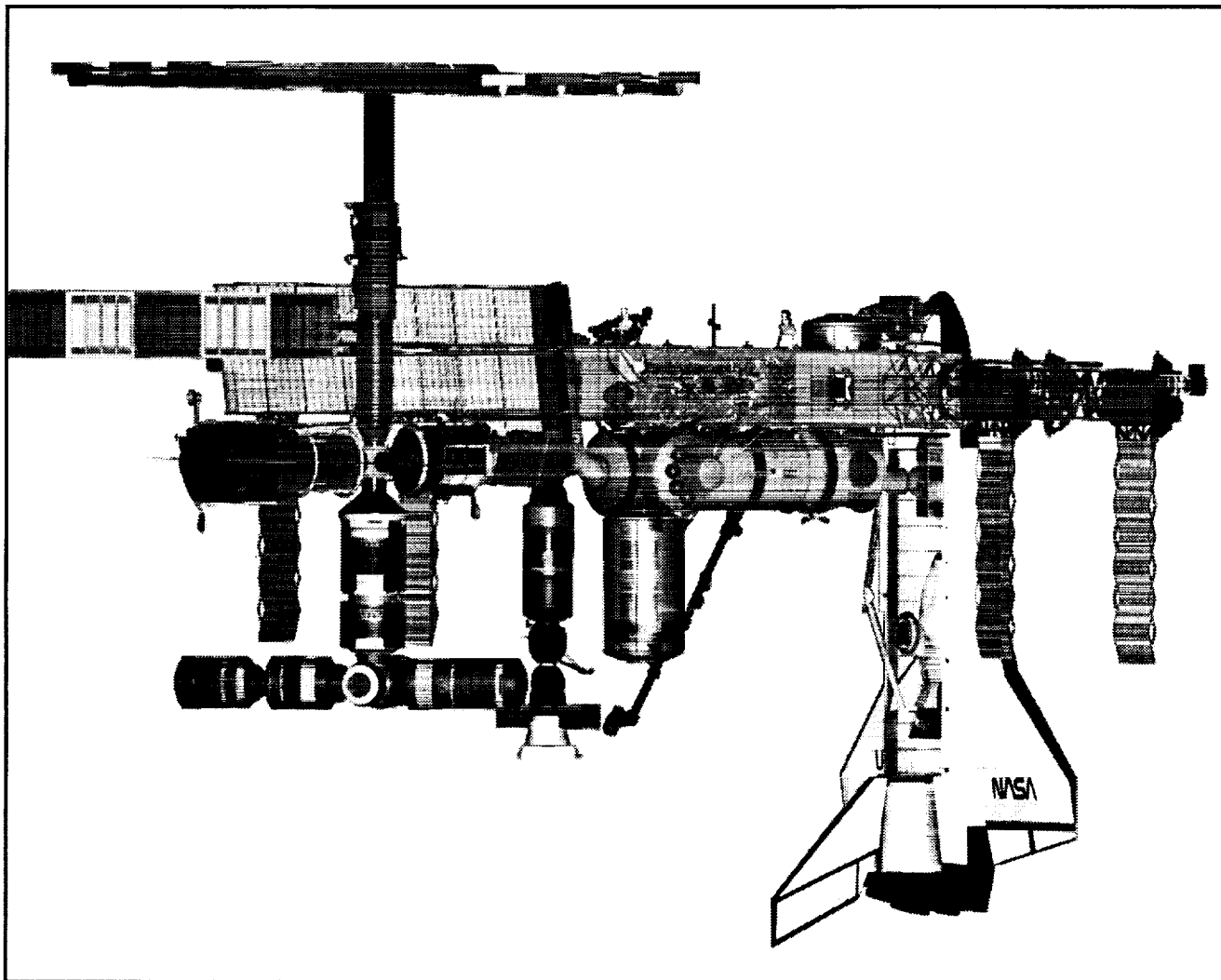

Figure 5.4-5: SRMS Grapples the ACRV in the Orbiter Bay

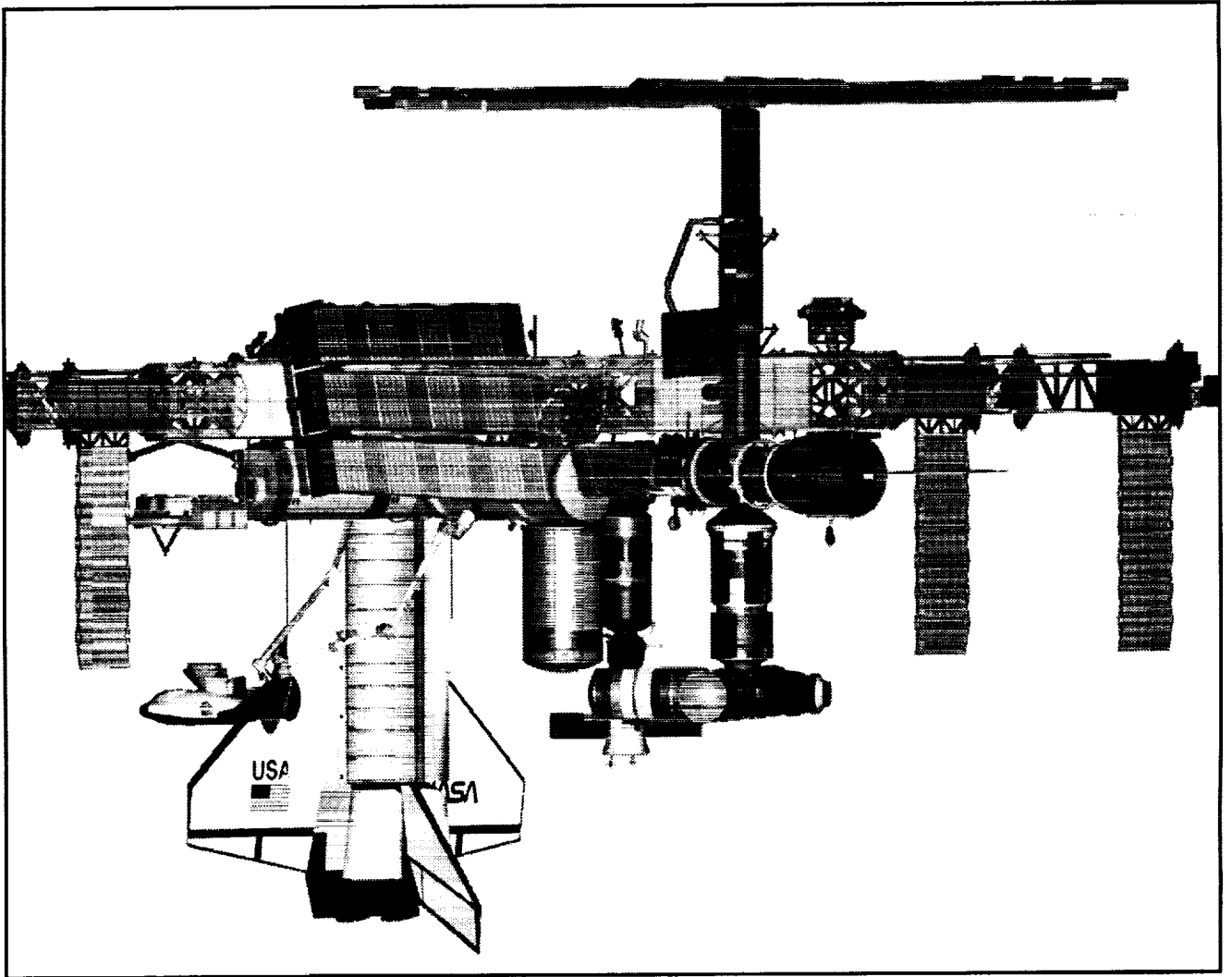

Figure 5.4-6: SRMS Hands the ACRV to the SSRMS using the Aft FRGFs

## 5.5 Swap-Out Scenario

The SSRMS removes the current ACRV from the nadir U.S. Habitation module and hands it to the SRMS (Figure 5.5-1).

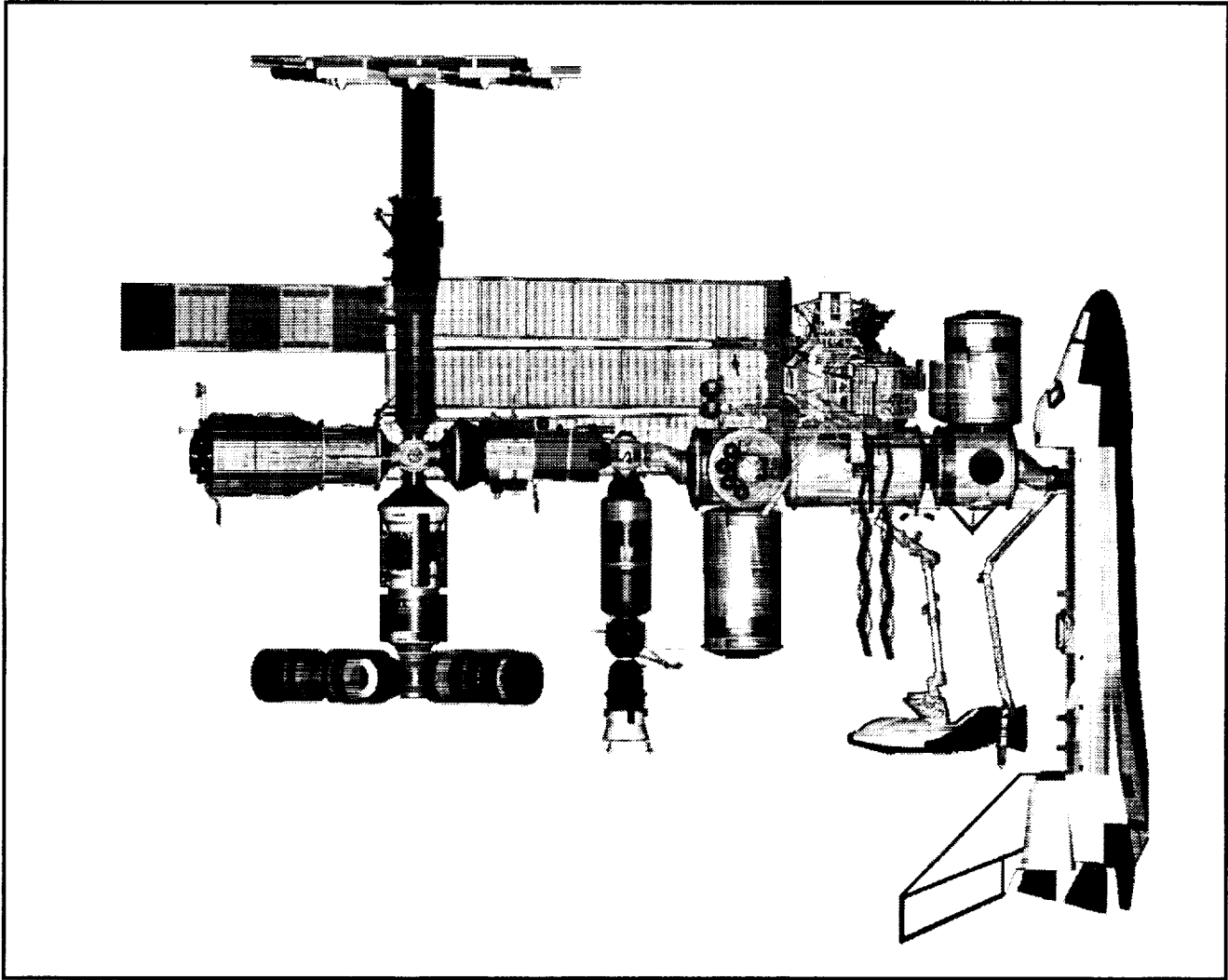

Figure 5.5-1: SSRMS Hands the ACRV to the SRMS

One of the installation sequences that uses the SSRMS alone is then performed. If the replacement ACRV is in the aft position, each ACRV will require its own modified PMA so that the station arm can grapple the FRGF located on the modified PMA (Figure 5.5-2).

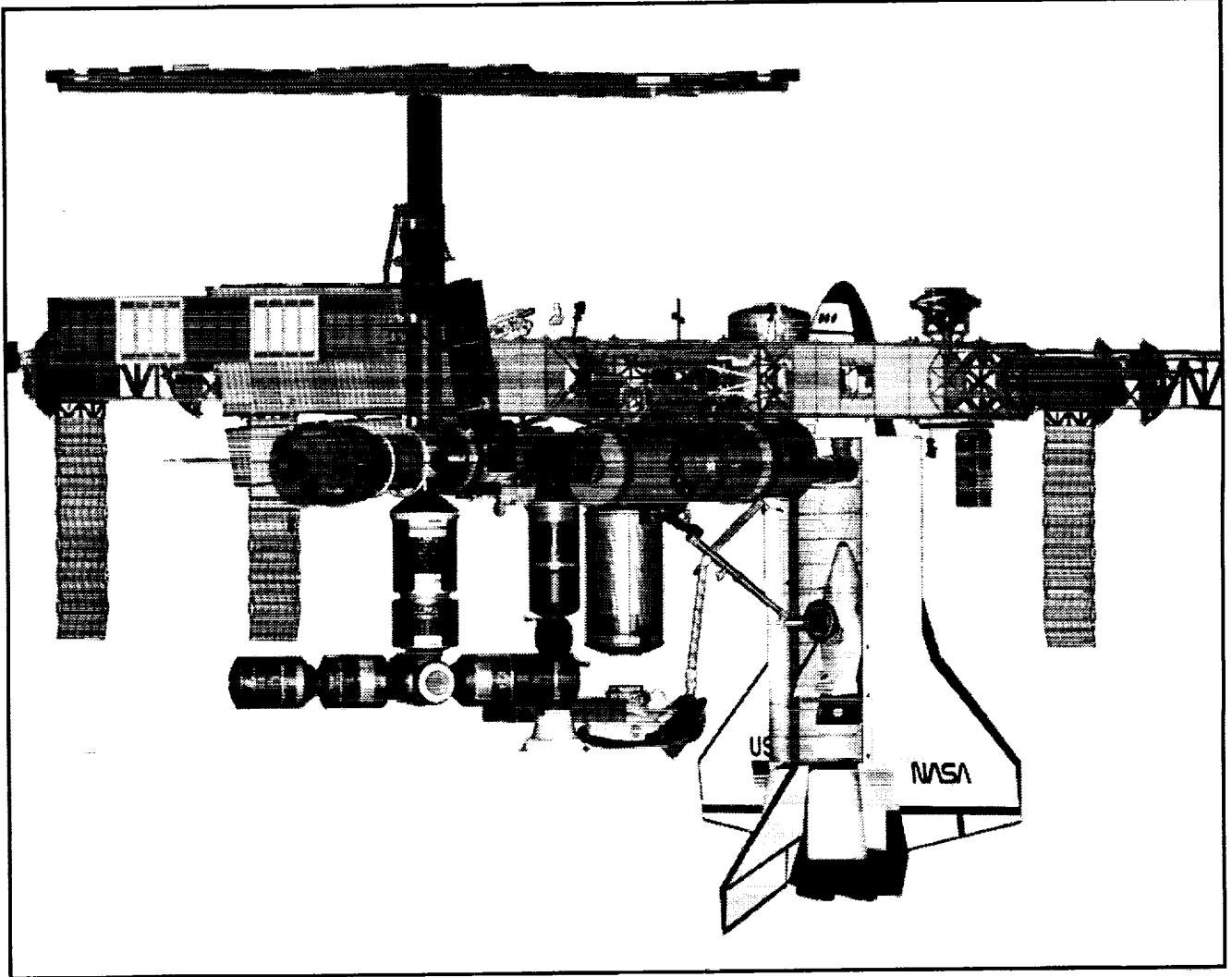

Figure 5.5-2: SSRMS Grapples the Replacement ACRV in the Orbiter Bay while the SRMS Holds the Original ACRV

If the replacement ACRV is located in the forward position, the second modified PMA is not necessary, however, there is a concern with the center of gravity location for the system when the ACRV is located in the forward position. These concerns are discussed in section 5.2.3. After the SSRMS has installed the replacement ACRV (Figure 5.5-3), the SRMS places the original ACRV in the Orbiter bay (Figure 5.5-4).

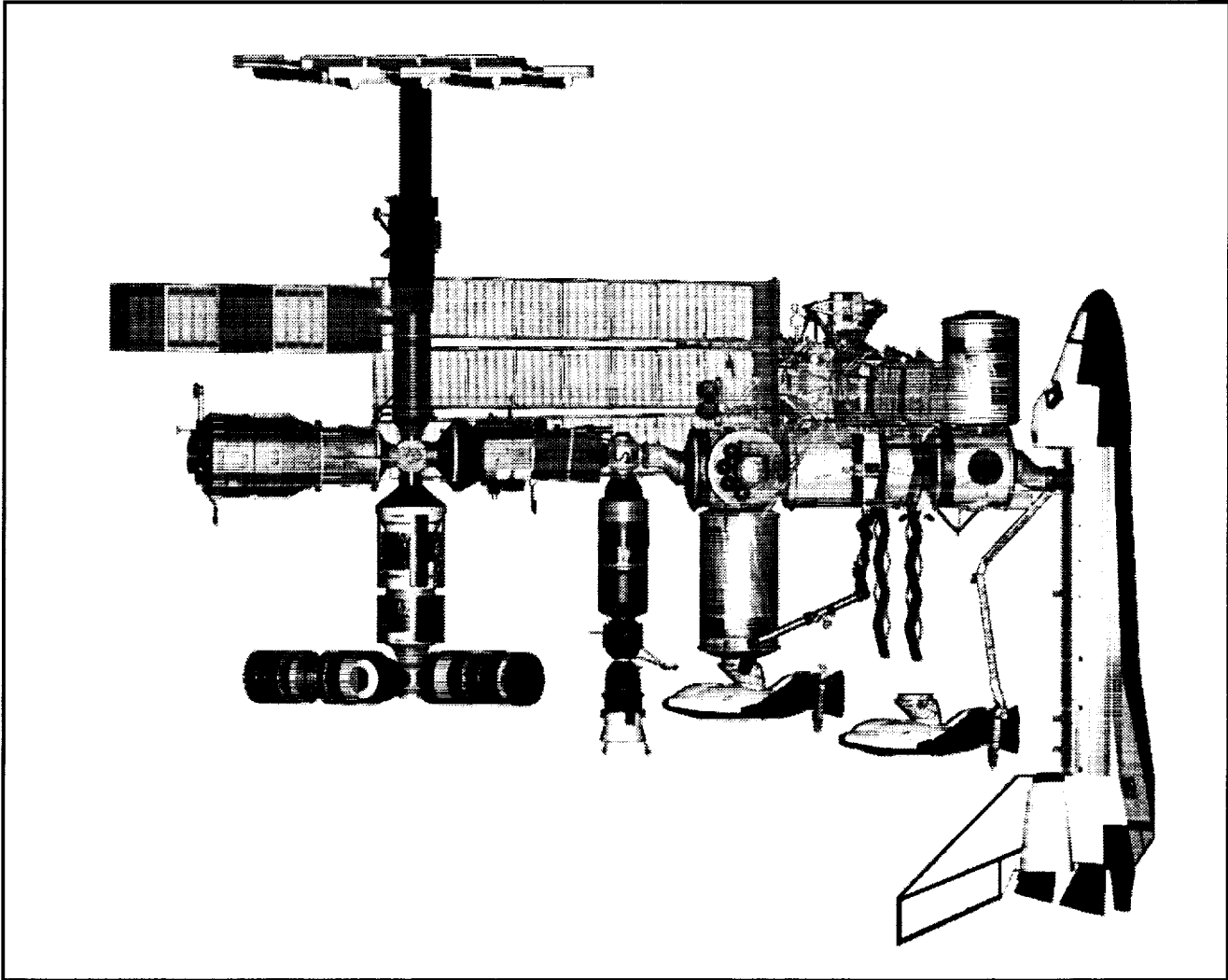

Figure 5.5-3: SSRMS Installs the Replacement ACRV on the ISSA

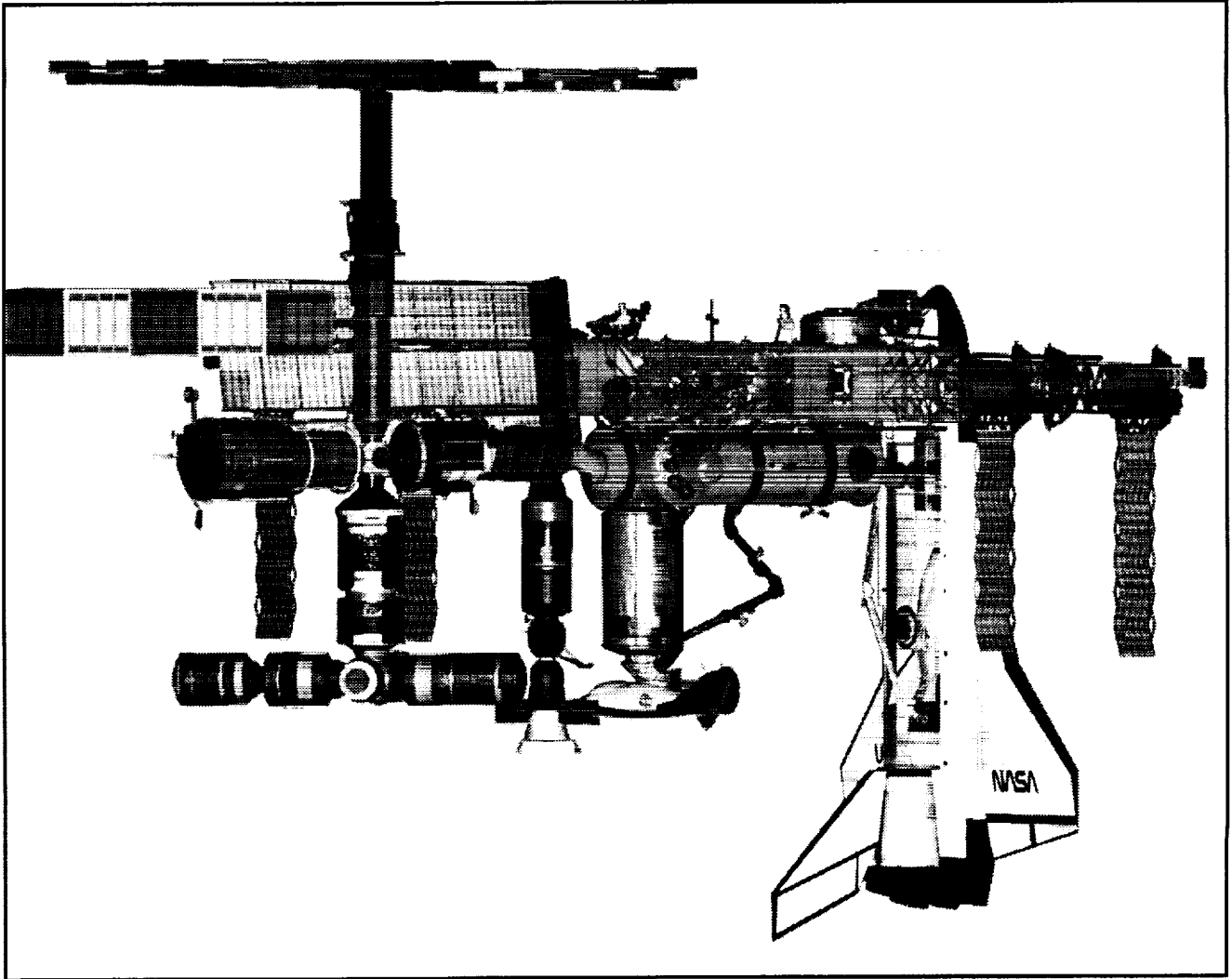

Figure 5.5-4: SRMS Places the Original ACRV in the Orbiter Bay

## **6.0 ACRV Separation Trajectory Analysis**

### **6.1 Analysis Assumptions**

The separation analysis was performed using the ADASS module of IDEAS<sup>2</sup>, an interdisciplinary analysis and design software developed at LaRC. ADASS is a six degree-of-freedom (6 DOF), rigid body simulation software tool. All separation simulations assume that the ISS and ACRV are in a 51.6 degree inclination orbit and are initially at an altitude of 230 nautical miles with a control design atmosphere ( $\text{Flux}_{10.7} = 230$ ,  $A_p = 140$ ). The simulations also assume that the ACRV is in a passive mode with regards to attitude control and secondary separation thrusting, due to the fact that the design of the ACRV is still on-going and no well defined attitude control system was available for analysis purposes. In addition, tip off rates due to the offset between the ACRV center of gravity (c.g.) and separation point were not analyzed due to c.g. position uncertainties. As the design of the ACRV becomes more defined, these parameters could be included in future separation trajectory analyses performed using ADASS.

#### **6.1.1 ISS Operating Conditions**

ACRV separation analyzed in this study was performed assuming an ISS Assembly Complete configuration initially oriented at its Torque Equilibrium Attitude (TEA) with all articular parts locked at their initial orientations (alpha and beta angles equal to 0.0 degrees). The ISS is assumed to nominally be operating in an LVLH flight mode. The initial attitude for all separation analyses was -2.9, -9.4, 0.8 degrees (Yaw-Pitch-Roll). Worst case angular rate offsets of +/- 0.65 deg/s were assumed about each ISS body axis as well as a baseline case ("free drift") with zero angular rate offsets (only orbit rate). The rates assumed are quite large considering that it takes the ISS nearly one orbit before it begins to "tumble" in an uncontrolled mode with no initial angular rate offsets. However, due to the uncertainty of the failure mode (i.e., thruster malfunction, explosive decompression, etc.), and the time between failure and station evacuation, these rates were assumed to attempt to provide an upper bound on the ISS attitude rates to highlight separation trajectory issues. A plot of the ISS attitude history for this free drift case is shown in Figure 6.1.1-1 and the accompanying attitude rates are shown in Figure 6.1.1-2.

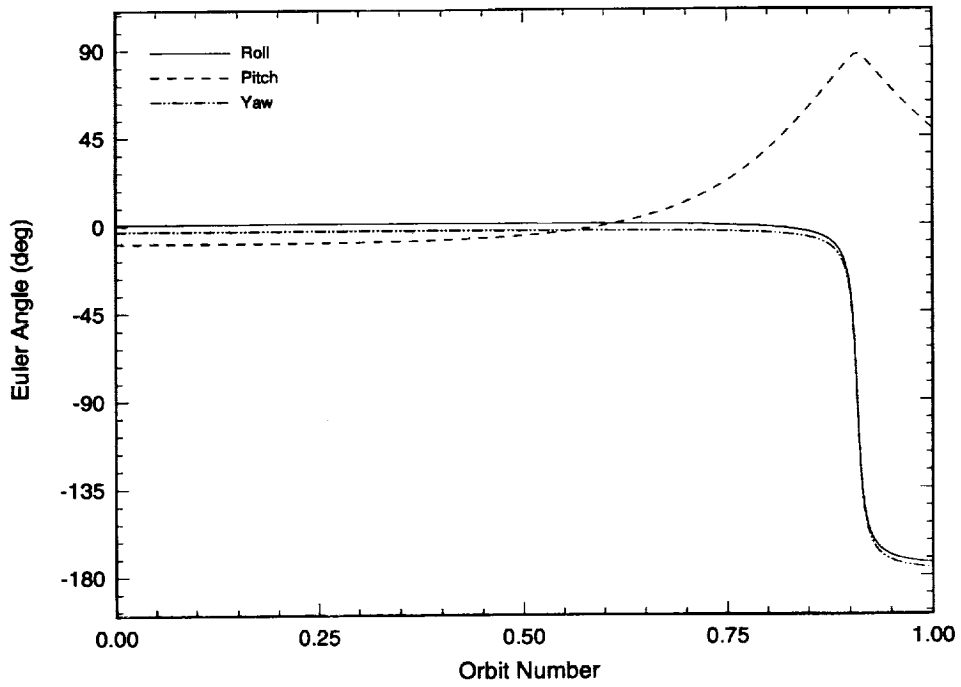

Figure 6.1.1-1: ISS "Free Drift" Attitude History (No Angular Rate Offsets)

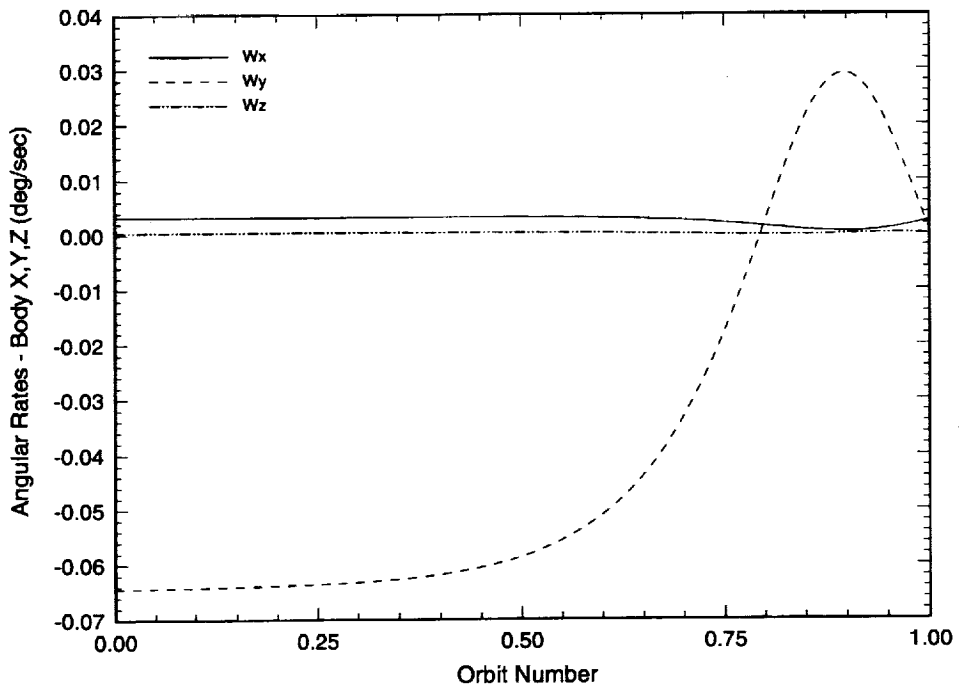

Figure 6.1.1-2: ISS "Free Drift" Attitude Rates (No Angular Rate Offsets)



### **6.1.2 ACRV Separation Configuration**

The ACRV is assumed to be attached to a modified PMA located on the nadir end of the U.S. HAB with the separation direction along the positive ISS body z-axis. The rear of the ACRV is oriented along the positive ISS body x-axis, which is primarily oriented in the velocity direction. The ACRV is assumed to have a minimum ballistic coefficient (BC) of 175 kg/m<sup>2</sup> and a maximum BC of 550 kg/m<sup>2</sup> depending on its orientation (projected area) with respect to the relative velocity vector.

### **6.1.3 ACRV Initial Separation Velocity**

Three initial separation  $\Delta V$ s from the ISS were assumed for each ISS angular rate offset analyzed. These three  $\Delta V$ s were 0.05, 0.10, and 0.20 m/s. These separation velocities were assumed to be non-propulsive, resulting from a spring loaded mechanism between the ISS and ACRV. Significantly higher separation rates are possible using the proposed ACRV GN<sub>2</sub> RCS thruster system, and would result in much better separation characteristics. Therefore, these simulations serve to identify the minimum separation velocities required under “worst case” ISS angular rates.

## **6.2 Separation Analysis Results**

The results of the separation analysis are presented in a tabular form in Tables 6.2-1 through 6.2-3, followed by two sets of complementary plots in Sections 6.2.1 and 6.2.2. Each table summarizes the results of a particular ACRV initial separation velocity, and highlights three important discriminators which measure the success of an ACRV departure for a given set of initial conditions. The first row of each table shows the minimum distance between the ACRV and ISS during the separation. A P symbol indicates that the distance between the two spacecraft is always increasing, while a T symbol indicates that a recontact has occurred. For simulations where the rotation of the ISS and departure path of the ACRV result in a decrease in the separation distance of the two vehicles, the minimum distance between them is shown in meters. The second row shows the time, in seconds, required for the ACRV to clear the ISS vicinity. This time is defined as the time required for the c.g. to c.g. distance of the two spacecraft to become greater than a distance equal to the sum of two reference radial distances defining the maximum envelope for each spacecraft (A complete discussion is provided in the section describing Figures 6.2.2-1 through 6.2.2-9). The third row lists the downrange separation distance between the ACRV and ISS after one orbit, assuming no orbital maneuvers are performed by either vehicle.

	No $\omega$	$-\omega_x$	$+\omega_x$	$-\omega_y$	$+\omega_y$	$-\omega_z$	$+\omega_z$
<b>Minimum ACRV/ISS Distance During Separation (m)</b> (P = always increasing) (T = recontact)	P	T	T	14.0	3.0	P	P
<b>Time To Clear ISS Vicinity (s)</b>	760	N/A	N/A	350	500	730	720
<b>Downrange Separation after 1 orbit (m)</b>	630	400	690	3280	-1860	520	560

Table 6.2-1: Separation Results Summary Chart for ACRV  $\Delta V = 0.05$  m/s

	No $\omega$	$-\omega_x$	$+\omega_x$	$-\omega_y$	$+\omega_y$	$-\omega_z$	$+\omega_z$
<b>Minimum ACRV/ISS Distance During Separation (m)</b> (P = always increasing) (T = recontact)	P	T	T	17.7	5.6	P	P
<b>Time To Clear ISS Vicinity (s)</b>	580	N/A	N/A	290	410	490	490
<b>Downrange Separation after 1 orbit (m)</b>	770	530	830	3440	-2100	660	700

Table 6.2-2: Separation Results Summary Chart for ACRV  $\Delta V = 0.10$  m/s

	No $\omega$	$-\omega_x$	$+\omega_x$	$-\omega_y$	$+\omega_y$	$-\omega_z$	$+\omega_z$
<b>Minimum ACRV/ISS Distance During Separation (m)</b> (P = always increasing) (T = recontact)	P	4.0	4.1	28.9	15.2	P	P
<b>Time To Clear ISS Vicinity (s)</b>	290	240	240	210	280	290	290
<b>Downrange Separation after 1 orbit (m)</b>	1040	810	1110	3750	-2220	930	980

Table 6.2-3: Separation Results Summary Chart for ACRV  $\Delta V = 0.20$  m/s

The first plots (Figures 6.2.1-1 through 6.2.1-14) show the In-Plane (IP) and Out-of-Plane (OOP) motion of the ACRV for each ISS angular rate offset studied. Each figure shows the relative motion between the c.g. of the ACRV and the c.g. of the ISS (plotted in a LVLH oriented reference frame) for all three ACRV  $\Delta V$  separation values. The x-axis for each plot is the downrange separation distance (X) and the y-axis shows either the altitude change (Z) or the OOP motion of the ACRV (Y). The time period for each of these plots is one orbit.

The second set of plots (Figures 6.2.2-1 through 6.2.2-9) depict the minimum distance between the ISS and ACRV for each ISS angular rate offset and each ACRV  $\Delta V$  as a function of time. A software algorithm was developed to read in the c.g. motion determined by ADASS along with the geometry data representing the ACRV and ISS, and output the minimum distance between the two spacecraft. A minimum distance of zero indicates that a recontact occurred between the ACRV and ISS during the separation simulation. The geometry of the two spacecraft are compared only for time steps when the ACRV and ISS are within a distance equal to the sum of two reference radial distances defining the maximum envelope for each spacecraft. The maximum distance from the c.g. to all the points which defined the geometry is calculated for each spacecraft. These distances are used to define spheres around the ACRV and ISS. The actual reference radial distances used for these simulations were approximately 5 meters for the ACRV and 71 meters for the ISS. When the ACRV c.g. and ISS c.g. are within the sum of these two radii, each point of the ISS geometry is evaluated to determine the closest point to the ACRV. Outside of this reference distance, simply the distance between the ISS c.g. and the ACRV c.g. is plotted. Therefore, the point at which there is an obvious discontinuity in the plot curve indicates the time it takes the ACRV to “clear the vicinity” of the ISS (provided that a recontact did not occur).

## 6.2.1 In-Plane and Out-of-Plane Motion Results

Figures 6.2.1-1 and 6.2.1-2 show the IP and OOP motion for the cases with no initial angular rate offset applied to the ISS. These plots demonstrate that the ACRV has a separation motion that causes the ACRV to go below and in front of the ISS. Assuming that the ACRV does not perform any orbital maneuvers, the downrange separation distance between the ACRV and ISS after one orbit is approximately 630m for a  $\Delta V$  of 0.05 m/s, 770 m for a  $\Delta V$  of 0.10 m/s, and 1040 m for a  $\Delta V$  of 0.20 m/s. The OOP motion is approximately one meter or less for each  $\Delta V$  simulated, due to the small initial attitude offsets.

Figures 6.2.1-3 and 6.2.1-4 show the IP and OOP motion for the cases with an initial angular rates offset of -0.65 deg/s applied about the ISS body x-axis. The separation motion also shows the ACRV to go below and in front of the ISS. The downrange separation is reduced for each  $\Delta V$  compared to the no rate simulations, due to the separation velocity component in the positive velocity direction resulting from the ISS angular motion. The distance is approximately 400 m for a  $\Delta V$  of 0.05 m/s, 530 m for a  $\Delta V$  of 0.10 m/s, and 810 m for a  $\Delta V$  of 0.20 m/s. The OOP motion is much greater than in the no rate simulations and is approximately 140 m for each  $\Delta V$  simulated due to the OOP separation velocity component added to the ACRV by the large negative  $\omega_x$  applied to the ISS.

Figures 6.2.1-5 and 6.2.1-6 show the IP and OOP motion for the cases with an initial angular rates offset of +0.65 deg/s applied about the ISS body x-axis. The separation motion also shows the ACRV to go below and in front of the ISS. The downrange separation is increased for each  $\Delta V$  compared to the no rate simulations, due to the separation velocity component in the negative velocity direction resulting from the ISS angular motion. The distance is approximately 690 m for a  $\Delta V$  of 0.05 m/s, 830 m for a  $\Delta V$  of 0.10 m/s, and 1110 m for a  $\Delta V$  of 0.20 m/s. The OOP motion is opposite of that shown for the negative  $\omega_x$  simulation, but the distance is approximately the same magnitude (140 m) for each  $\Delta V$  simulated.

Figures 6.2.1-7 and 6.2.1-8 show the IP and OOP relative motion for the case with an initial angular rate offset of -0.65 deg/s applied about the ISS body y-axis. The separation motion initially has the ACRV falling below and behind the ISS for a brief period. However, the ACRV eventually moves in front of the ISS due to large separation velocity component in the negative velocity direction. This simulation has the largest downrange separation on any of the angular rate cases simulated. The downrange distance is approximately 3280 meters for a  $\Delta V$  of 0.05 m/s, 3440 meters for a  $\Delta V$  of 0.10 m/s, and 3750 meters for a  $\Delta V$  of 0.20 m/s. The OOP motion is between 6 and 7 meters for the range of  $\Delta V$ s simulated, due to the combination of the ISS being initially oriented at its TEA and the negative rotational velocity applied about the body y-axis.

Figures 6.2.1-9 and 6.2.1-10 show the IP and OOP relative motion for the case with an initial angular rate offset of +0.65 deg/s applied about the ISS body y-axis. The separation motion initially has the ACRV falling below and in front of the ISS for a brief period, but the tangential velocity imparted on the ACRV causes it to go into a higher orbit and subsequently fall behind the ISS. This is the only case simulated that results in the ACRV having negative downrange separations after one orbit. The downrange distance is approximately -1860 meters for a  $\Delta V$  of 0.05 m/s, -2100 meters for a  $\Delta V$  of 0.10 m/s, and -2220 meters for a  $\Delta V$  of 0.20 m/s. The OOP motion is between 7 and 8 meters for the range of  $\Delta V$ s simulated, and is basically opposite of that resulting from the negative  $\omega_y$  applied in the previous simulation case.

Figures 6.2.1-11 and 6.2.1-12 show the IP and OOP relative motion for the case with an initial angular rate offset of -0.65 deg/s applied about the ISS body z-axis. The downrange distance is only affected minimally by the negative  $\omega_z$  applied, and is approximately 520 meters for a  $\Delta V$  of 0.05 m/s, 660 meters for a  $\Delta V$  of 0.10 m/s, and 930 meters for a  $\Delta V$  of 0.20 m/s. The OOP motion is substantial due to the negative y-axis velocity imparted on the ACRV due to negative body z-axis rotational velocity applied. This is a result of the c.g. of the composite ISS being aft of the ACRV at separation. The maximum OOP separation is approximately 38 meters for each of the  $\Delta V$ s simulated.

Figures 6.2.1-13 and 6.2.1-14 show the IP and OOP relative motion for the case with an initial angular rate offset of +0.65 deg/s applied about the ISS body z-axis. Again, the downrange distance is only affected minimally by the  $\omega_z$  applied (this time positive), and is approximately 560 meters for a  $\Delta V$  of 0.05 m/s, 700 meters for a  $\Delta V$  of 0.10 m/s, and 980 meters for a  $\Delta V$  of 0.20 m/s. The OOP motion is basically opposite of that in shown Figure 6.1-12 for the same reasons discussed above, and the maximum OOP separation is approximately 36 meters for each of the  $\Delta V$ s simulated.

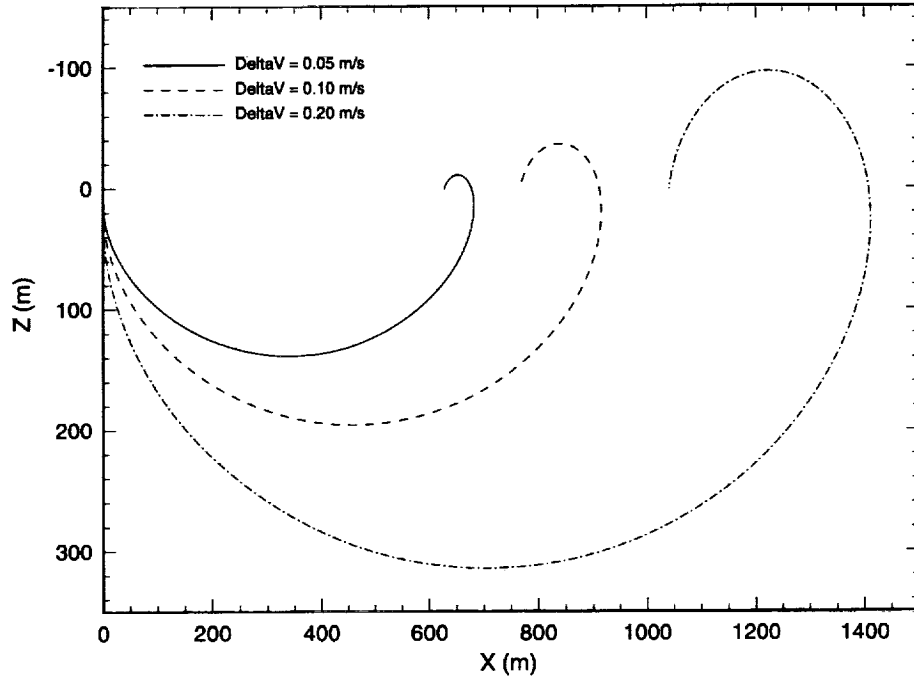

Figure 6.2.1-1: In-Plane Motion for No ISS Angular Rate Offsets

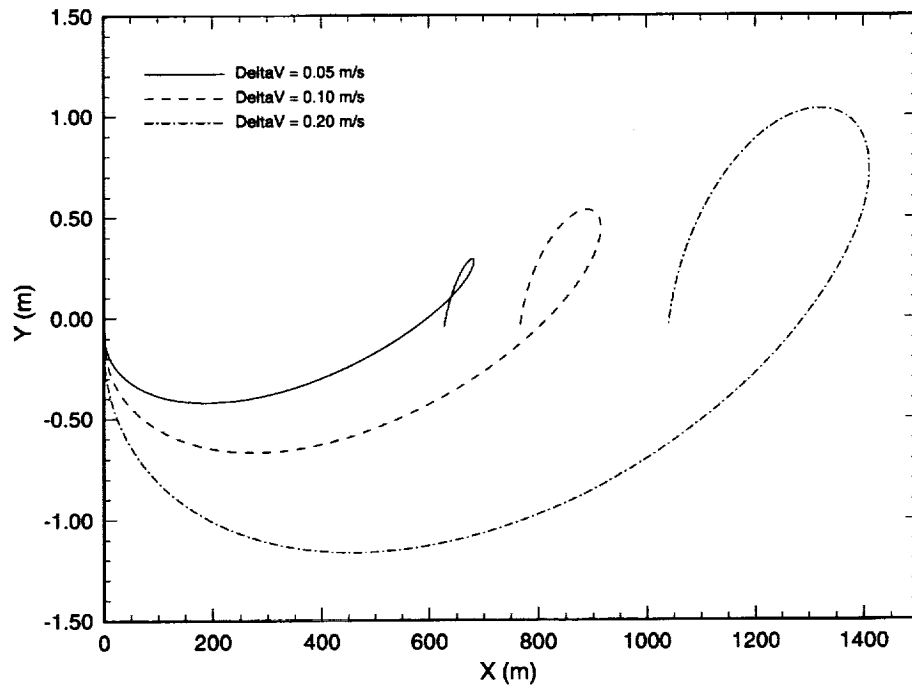

Figure 6.2.1-2: Out-of-Plane Motion for No ISS Angular Rate Offsets

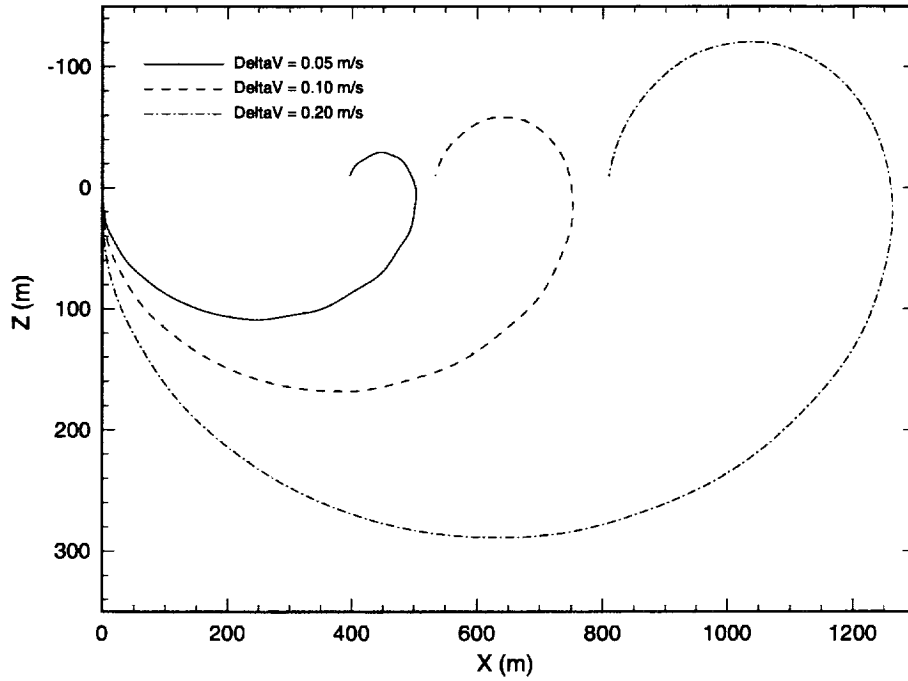

Figure 6.2.1-3: In-Plane Motion for ISS  $\omega_x = -0.65$  deg/s

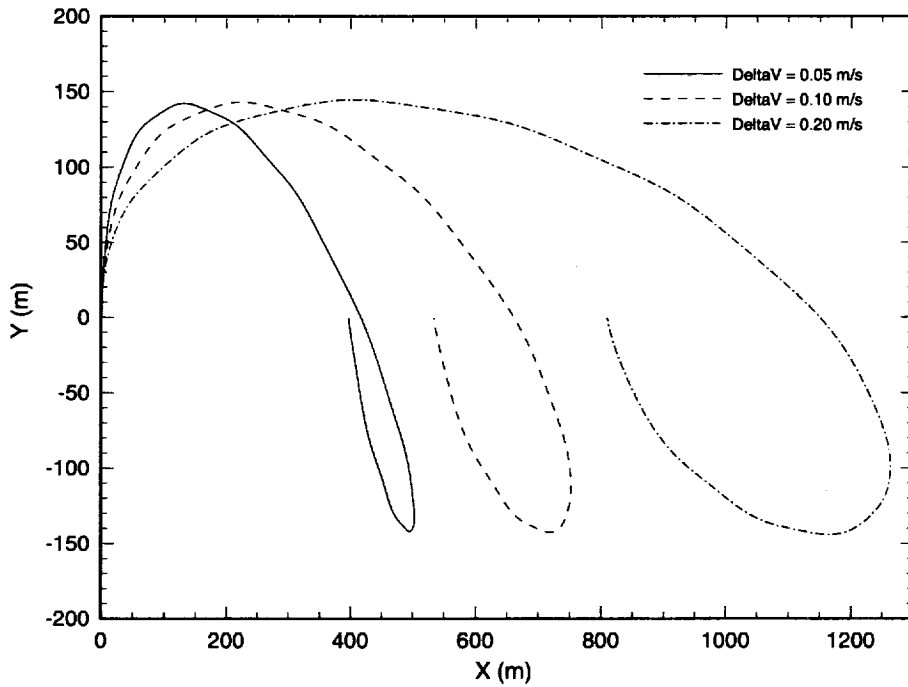

Figure 6.2.1-4: Out-of-Plane Motion for ISS  $\omega_x = -0.65$  deg/s

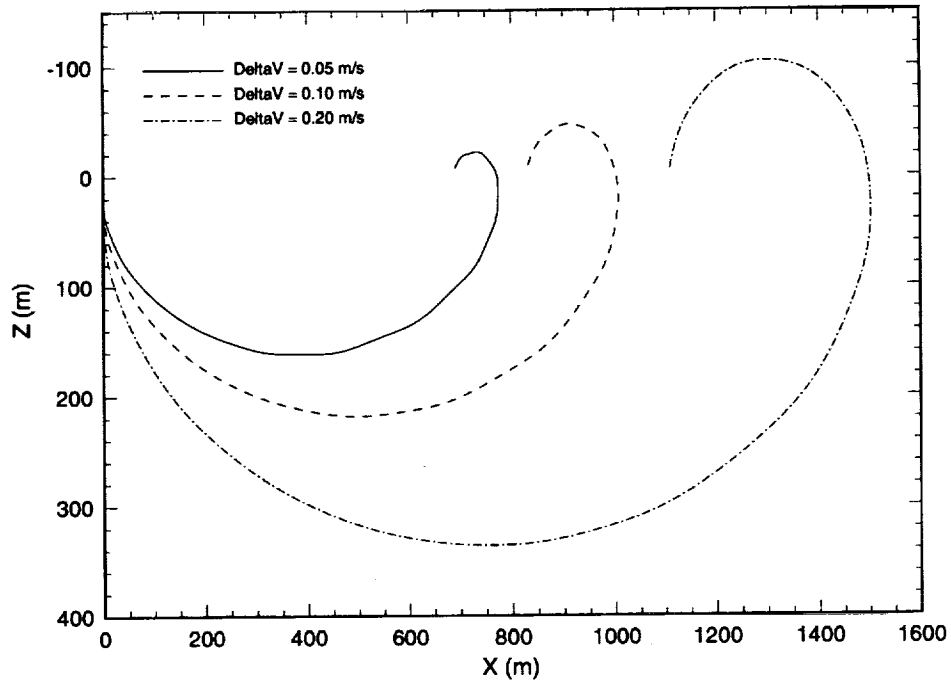

Figure 6.2.1-5: In-Plane Motion for ISS  $\omega_x = +0.65$  deg/s

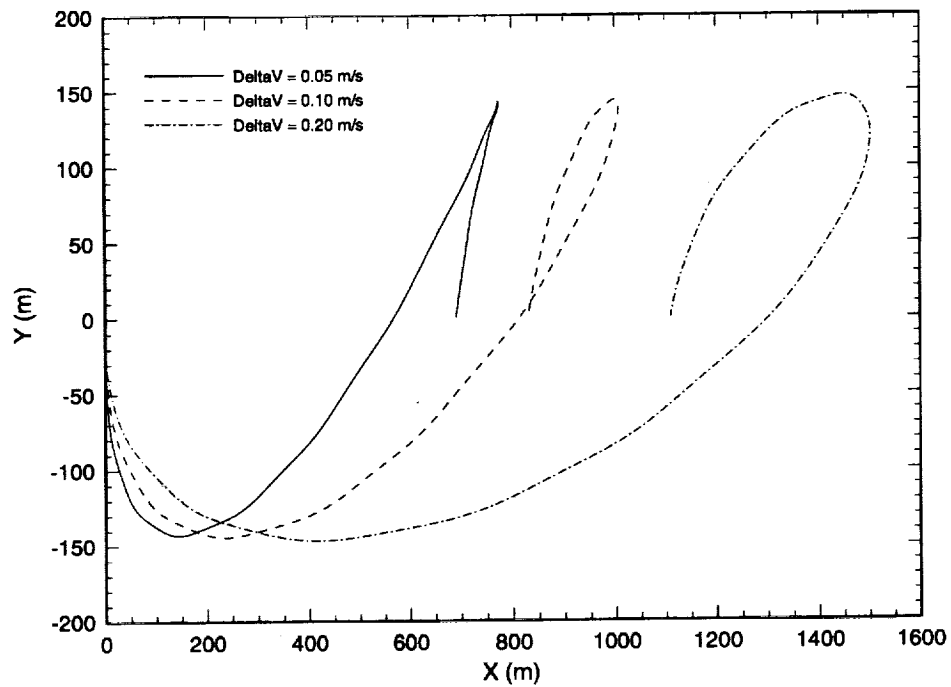

Figure 6.2.1-6: Out-of-Plane Motion for ISS  $\omega_x = +0.65$  deg/s



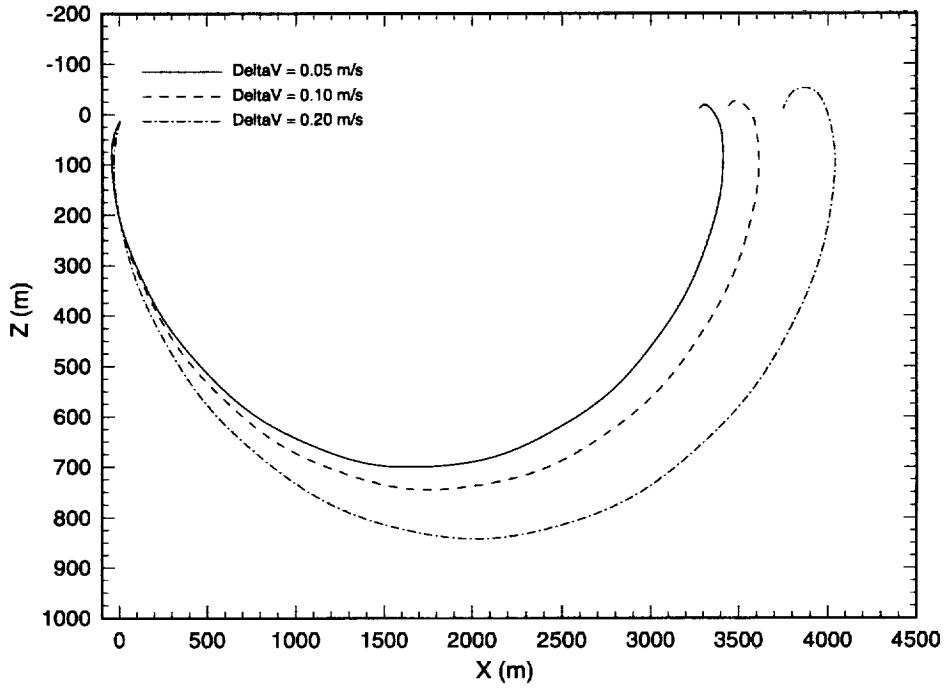

Figure 6.2.1-7: In-Plane Motion for ISS  $\omega_y = -0.65$  deg/s

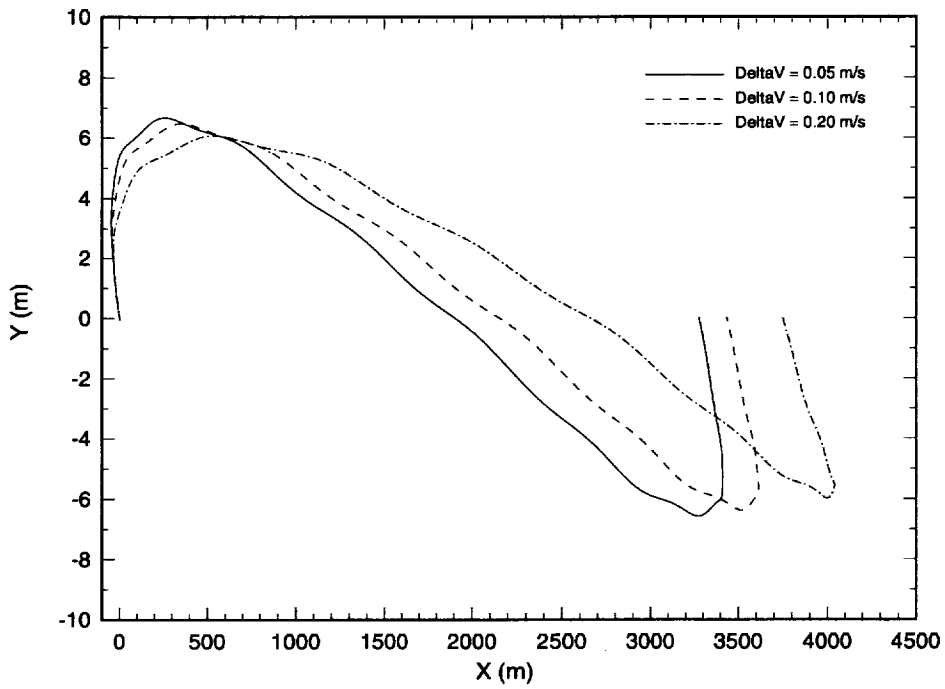

Figure 6.2.1-8: Out-of-Plane Motion for ISS  $\omega_y = -0.65$  deg/s

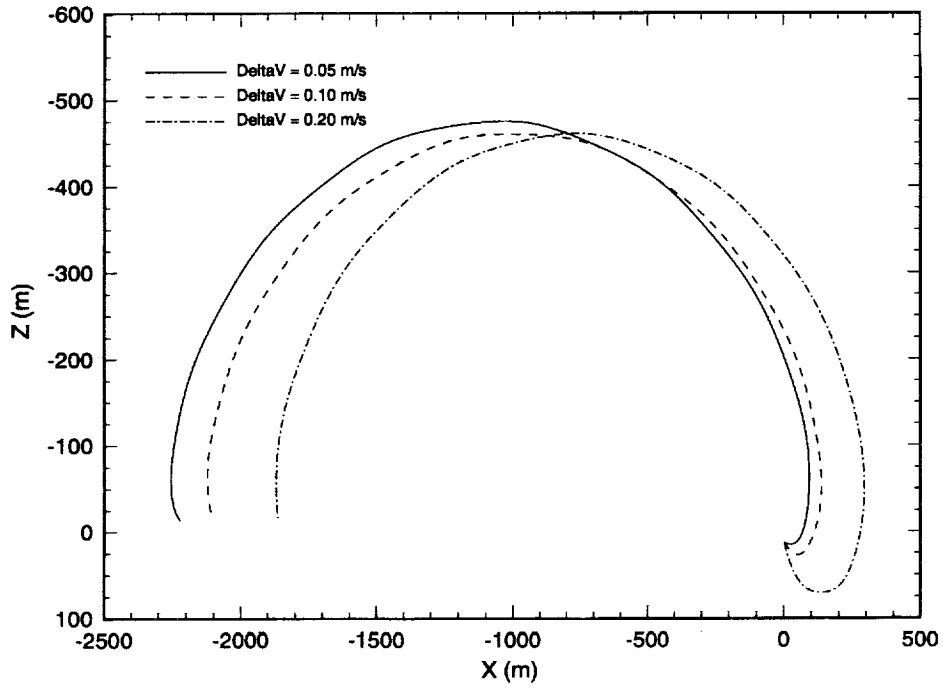

Figure 6.2.1-9: In-Plane Motion for ISS  $\omega_y = +0.65$  deg/s

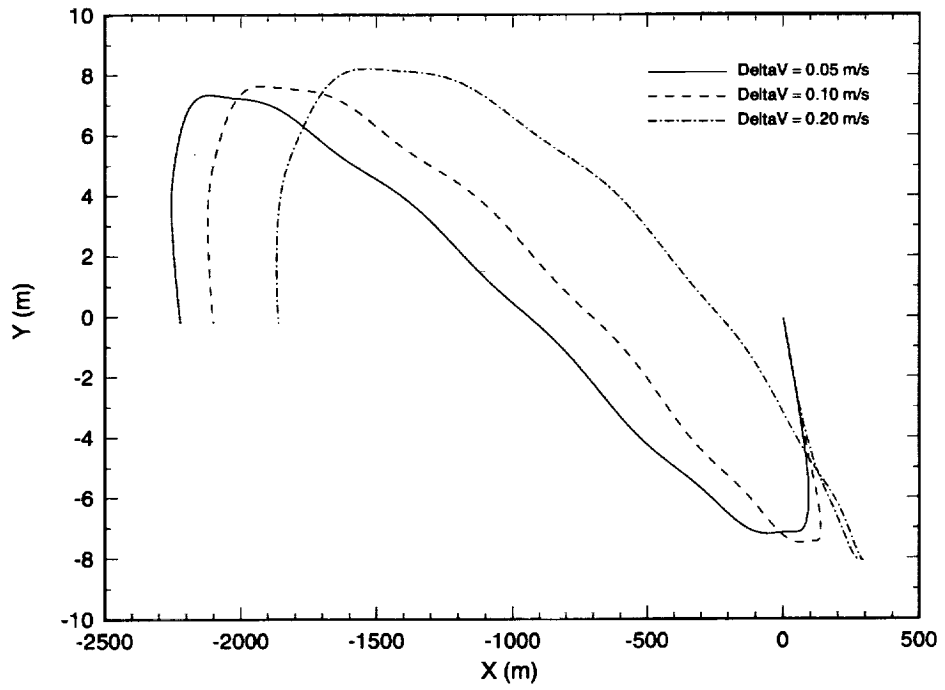

Figure 6.2.1-10: Out-of-Plane Motion for ISS  $\omega_y = +0.65$  deg/s

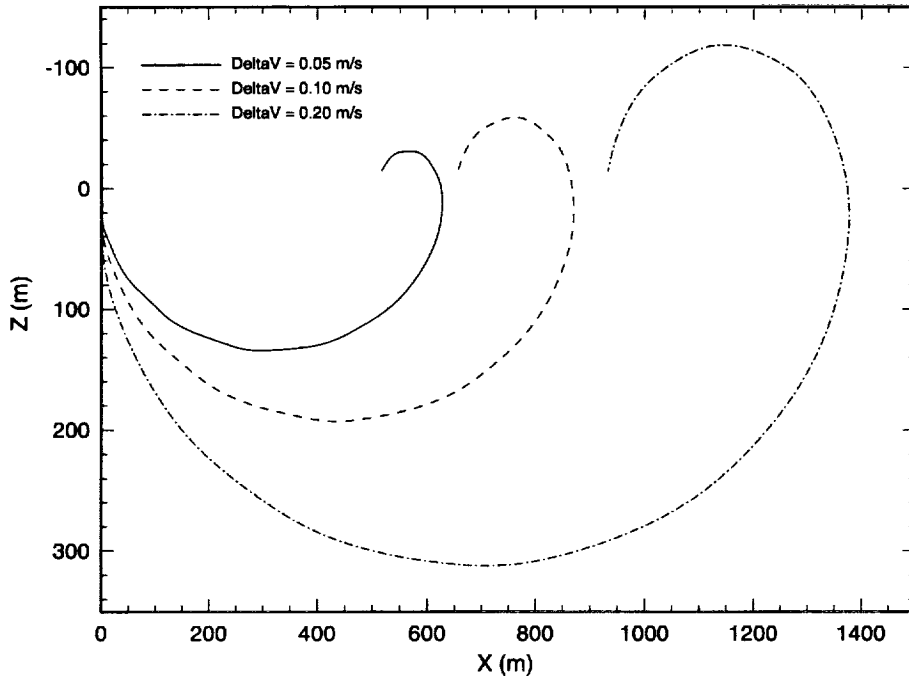

Figure 6.2.1-11: In-Plane Motion for ISS  $\omega_z = -0.65$  deg/s

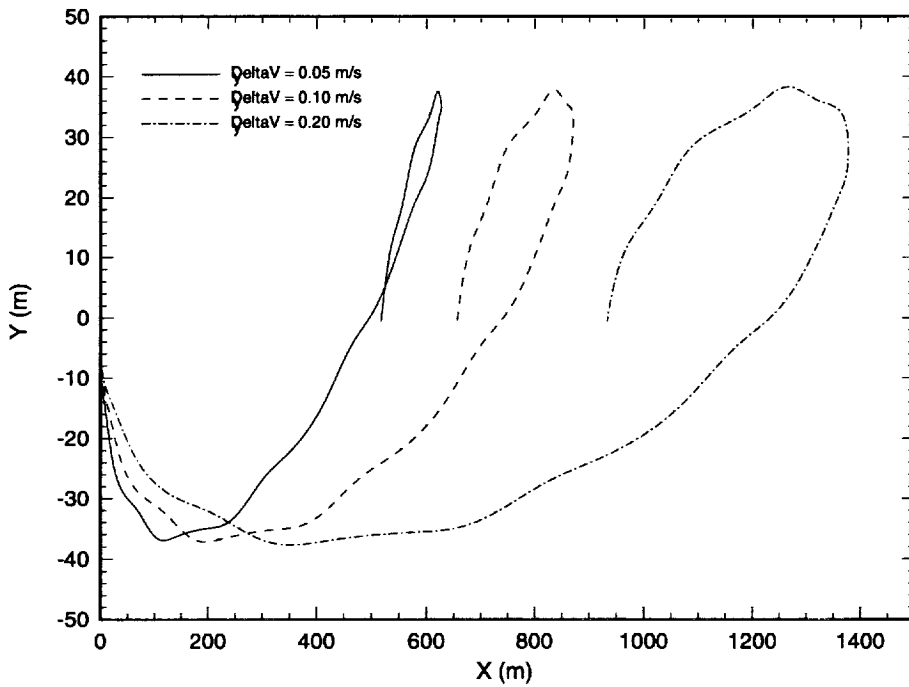

Figure 6.2.1-12: Out-of-Plane Motion for ISS  $\omega_z = -0.65$  deg/s

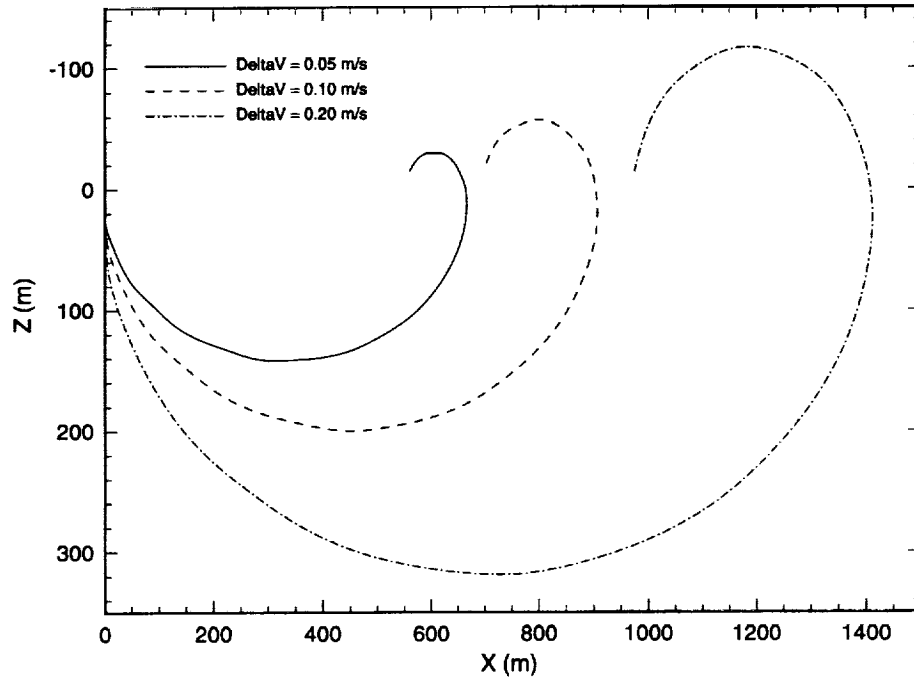

Figure 6.2.1-13: In-Plane Motion for ISS  $\omega_z +0.65$  deg/s

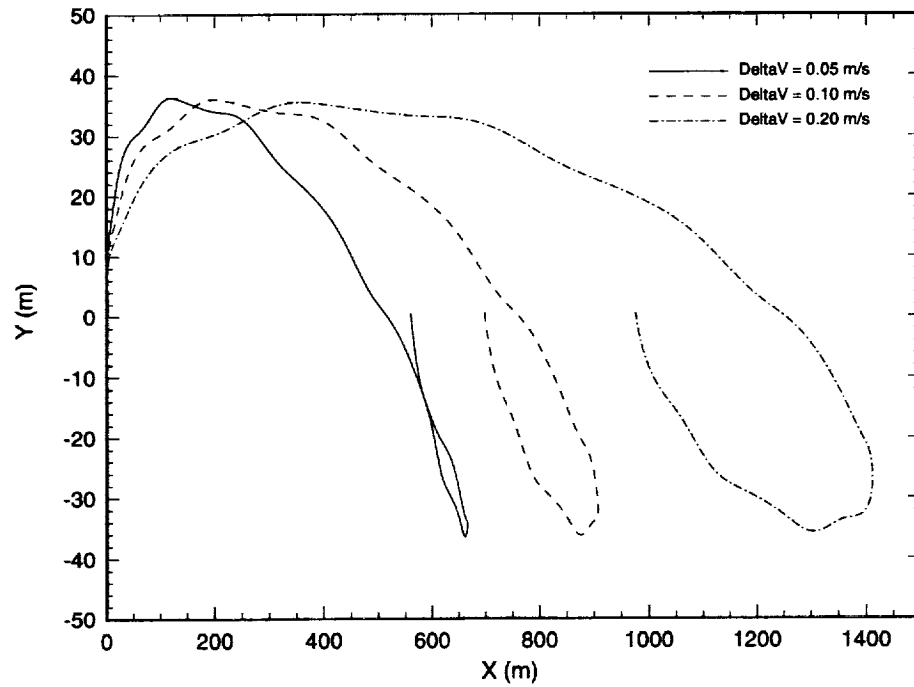

Figure 6.2.1-14: Out-of-Plane Motion for ISS  $\omega_z = +0.65$  deg/s

## 6.2.2 ISS/ACRV Minimum Distance Results

The previous figures depict the overall c.g.-c.g. motion of the two spacecraft during departure. Of greater importance is how close the ACRV and ISS come to each other during the separation. Figures 6.2.2-1 through 6.2.2-9 plot the minimum distance between the ACRV and the ISS for the three  $\Delta V$ s studied and the  $\pm 0.65$  deg/s angular velocity applied to each ISS body axis direction, as well as the “free drift” case for the appropriate  $\Delta V$ . As described in section 6.2, the discontinuity in each plot curve indicates the point in time when the ACRV has, by definition, cleared the vicinity of the ISS. At this point the c.g. to c.g. distance is plotted rather than the minimum distance between the ACRV and the ISS.

Figure 6.2.2-1 shows that for a  $\Delta V$  of only 0.05 m/s, ACRV recontact with the ISS occurs at 230 seconds for the  $\omega_x = +0.65$  deg/s case and at 220 seconds for the  $\omega_x = -0.65$  deg/s case. The ACRV does not have sufficient time to clear the integrated truss assembly and collides with the truss near the photovoltaic arrays as the station rotates about its body x-axis. The no angular rate case clearly shows a steady increase in minimum separation distance and clears the vicinity of the ISS in 760 seconds.

Figure 6.2.2-2 shows that the same recontact problem exists for a  $\Delta V$  of 0.10 m/s for both  $\omega_x$  angular rates. The recontact occurs slightly farther down the ISS truss, but actually occurs slightly sooner due to the combination of the greater  $\Delta V$  and the tangential velocity caused by the  $\omega_x$  of the ISS. The recontact time is approximately 180 seconds for both the positive and negative  $\omega_x$  cases. For the no angular rate case, the time to clear (TTC) the vicinity of the ISS decreases to around 580 seconds due to the larger  $\Delta V$ .

Figure 6.2.2-3 shows that a  $\Delta V$  of 0.20 m/s is sufficient for the ACRV to clear the ISS even with “worst case” body x-axis rates of  $\pm 0.65$  deg/s. The ACRV does however still come within 4.0 meters at 160 seconds after separation for the negative  $\omega_x$  case, and 4.1 meters at 180 seconds for the positive  $\omega_x$  case. The TTC for both cases is 240 seconds. For the no angular rate case, the TTC is 290 seconds for the largest  $\Delta V$  studied in this analysis.

There are no recontact issues for any of the  $\omega_y$  cases. However, for the positive  $\omega_y$  cases, there should be some concern with the proximity of some of the ISS hardware to the ACRV when the station rotates rapidly about its body y-axis. Specifically, the Russian Progress module located at the aft end of the ISS comes within 3.0 meters of the ACRV for a  $\Delta V$  of 0.05 m/s as shown in Figure 6.2.2-4. Conversely, the additional separation velocity due to a negative  $\omega_y$  angular rate offset actually allows for better separation distances than the no angular rate case. The ACRV does begin to come closer to the ISS briefly, but the separation distance is still approximately 14.0 meters as the ISS rotates toward the departing ACRV. The TTC for negative  $\omega_y$  case is only 350 seconds, and increases to 500 seconds for the positive  $\omega_y$  case. Both of these TTCs are shorter than the no angular rate case.

Figure 6.2.2-5 shows that for a  $\Delta V$  of 0.10 m/s, the minimum distance is increased to 5.6 meters at 230 seconds for the positive  $\omega_y$  case and 17.7 meters at 140 seconds for the negative  $\omega_y$  case. The TTCs for these simulations are reduced to 410 and 290 seconds for the positive and negative  $\omega_y$  cases, respectively. Once again, the negative  $\omega_y$  shows larger separation distances than the no angular rate case.

Figure 6.2.2-6 shows the separation performance for a  $\Delta V$  of 0.20 m/s. The minimum distance is again increased. The minimum distance is 15.2 meters at 150 seconds for the positive  $\omega_y$  case and 28.9 meters at 160 seconds for the negative  $\omega_y$  case. Note that for this case the separation distance is almost always increasing, only briefly does the distance decrease slightly during the separation. The TTCs for this combination ACRV  $\Delta V$ s and ISS angular rates are 280 and 210 seconds for the positive and negative  $\omega_y$  cases, respectively.

Finally, Figures 6.2.2-7 through 6.2.2-9 show that there are no separation issues with any of the  $\Delta V$ s studied with regards to an  $\omega_z$  of +/- 0.65 deg/s. The ISS rotating about its body z-axis, either positively or negatively, has no significant impact on the ACRV which is departing along the positive ISS body z-axis. At no point in time is the minimum distance between the two spacecraft ever decreasing and the TTC for both the positive and negative  $\omega_z$  cases are almost the same as the no angular rate case for each ACRV  $\Delta V$ - approximately 720 seconds for a  $\Delta V$  of 0.05 m/s, 490 seconds for a  $\Delta V$  of 0.10 m/s, and 290 seconds for a  $\Delta V$  of 0.20 m/s.

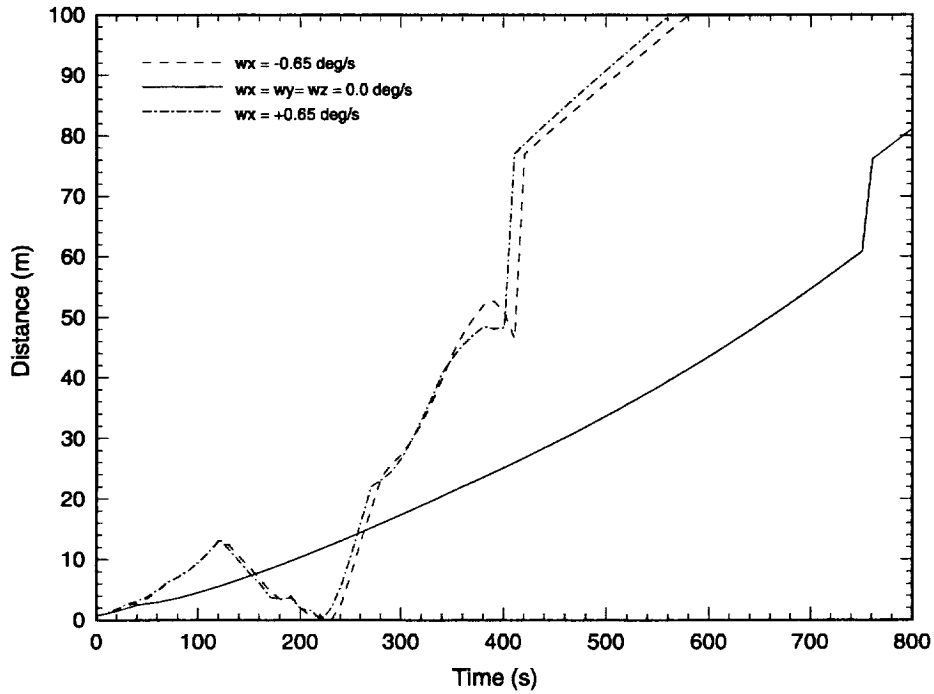

Figure 6.2.2-1: Minimum Distance Between ACRV and ISS  
 ISS  $\omega_x = \pm 0.65 \text{ deg/s}$  and ACRV  $\Delta V = 0.05 \text{ m/s}$

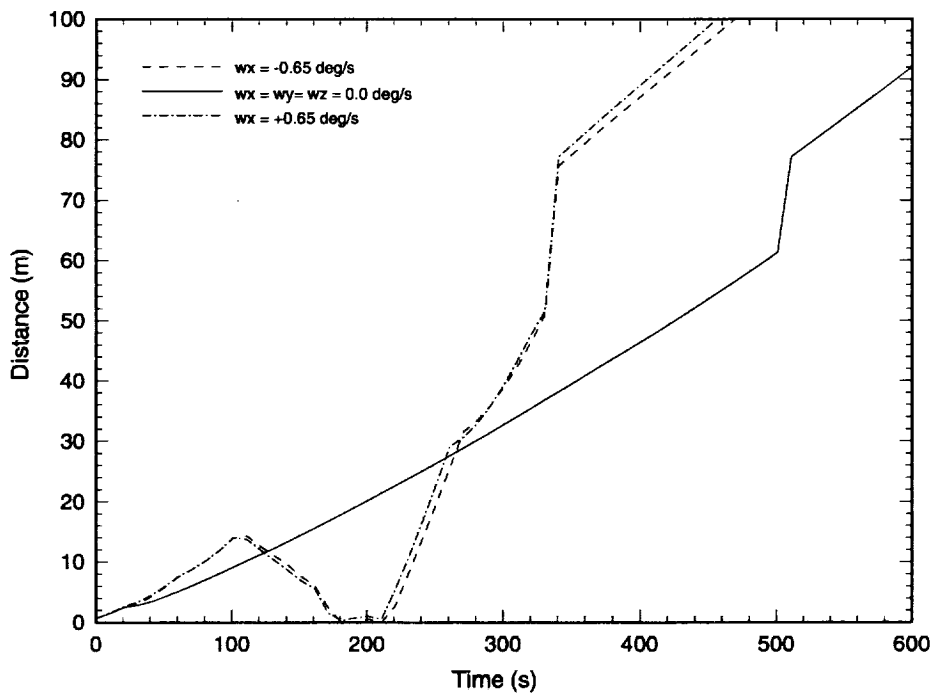

Figure 6.2.2-2: Minimum Distance Between ACRV and ISS  
 ISS  $\omega_x = \pm 0.65 \text{ deg/s}$  and ACRV  $\Delta V = 0.10 \text{ m/s}$

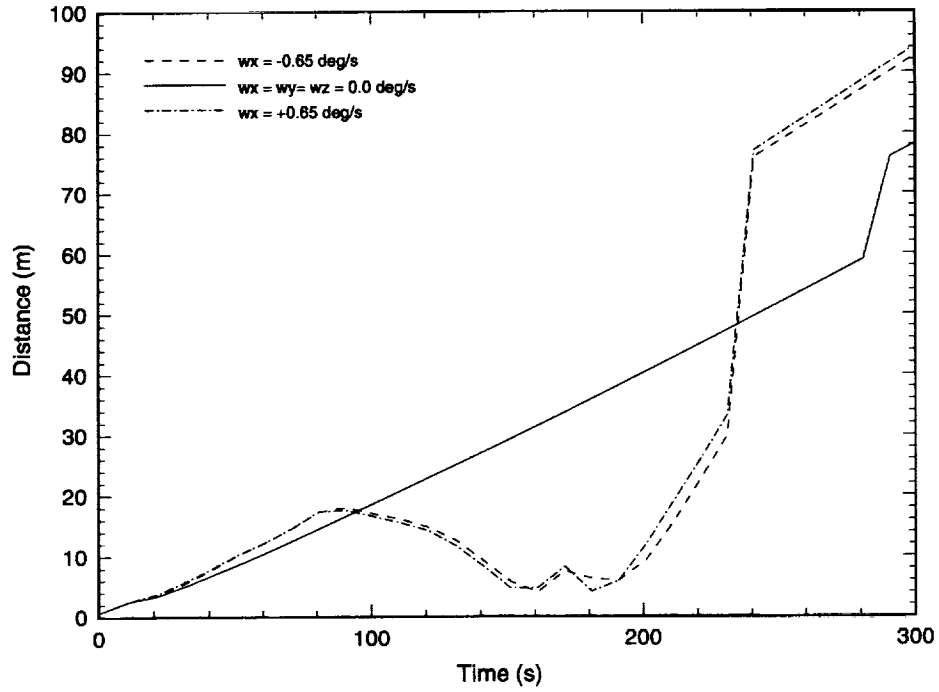

Figure 6.2.2-3: Minimum Distance Between ACRV and ISS  
 ISS  $\omega_x = \pm 0.65$  deg/s and ACRV  $\Delta V = 0.20$  m/s

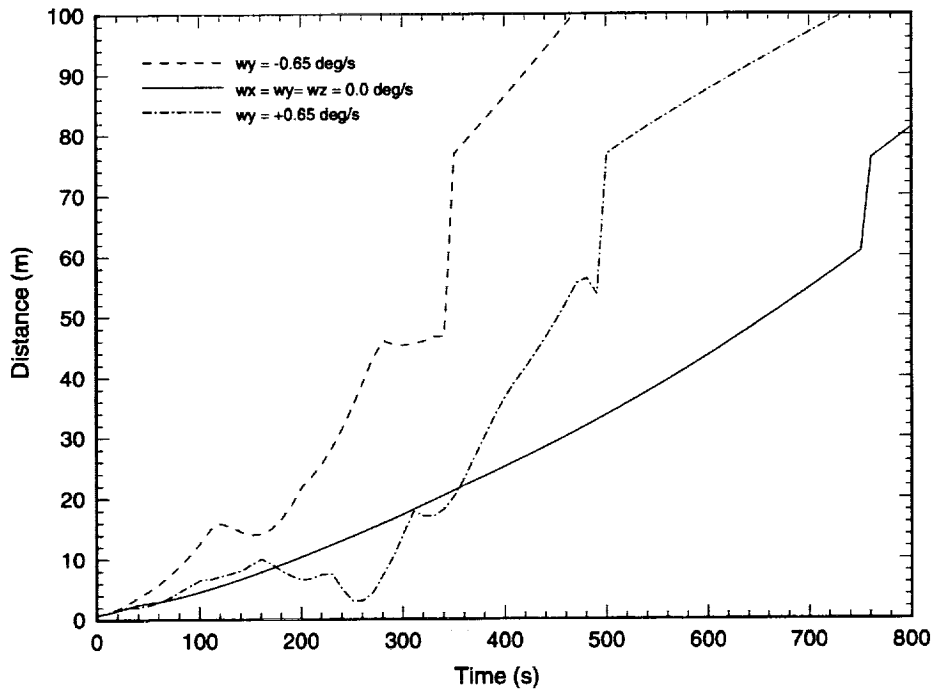

Figure 6.2.2-4: Minimum Distance Between ACRV and ISS  
 ISS  $\omega_y = \pm 0.65$  deg/s and ACRV  $\Delta V = 0.05$  m/s



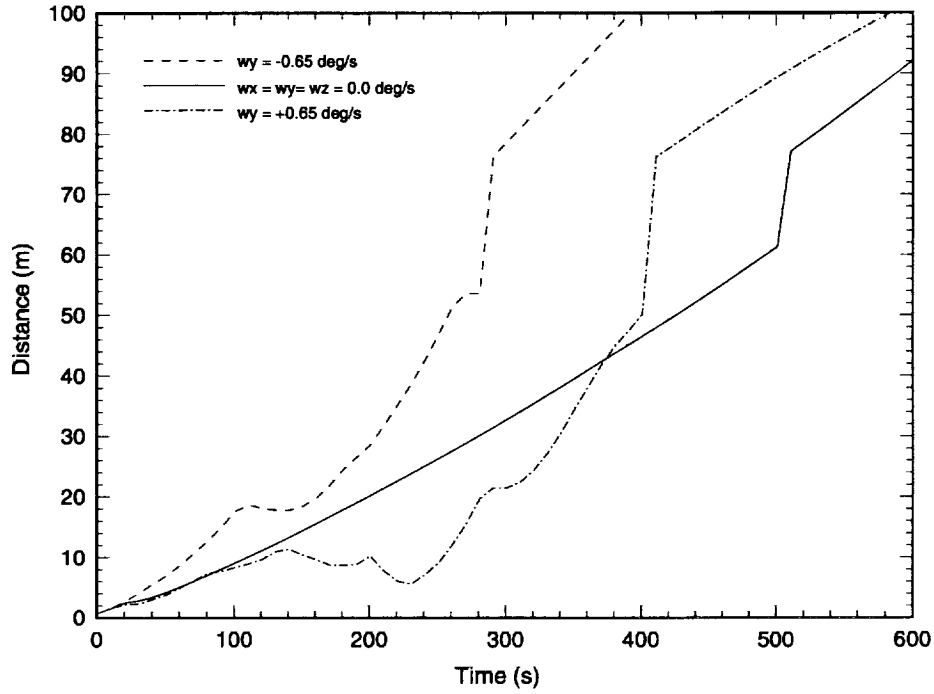

Figure 6.2.2-5: Minimum Distance Between ACRV and ISS  
 ISS  $\omega_y = \pm 0.65$  deg/s and ACRV  $\Delta V = 0.10$  m/s

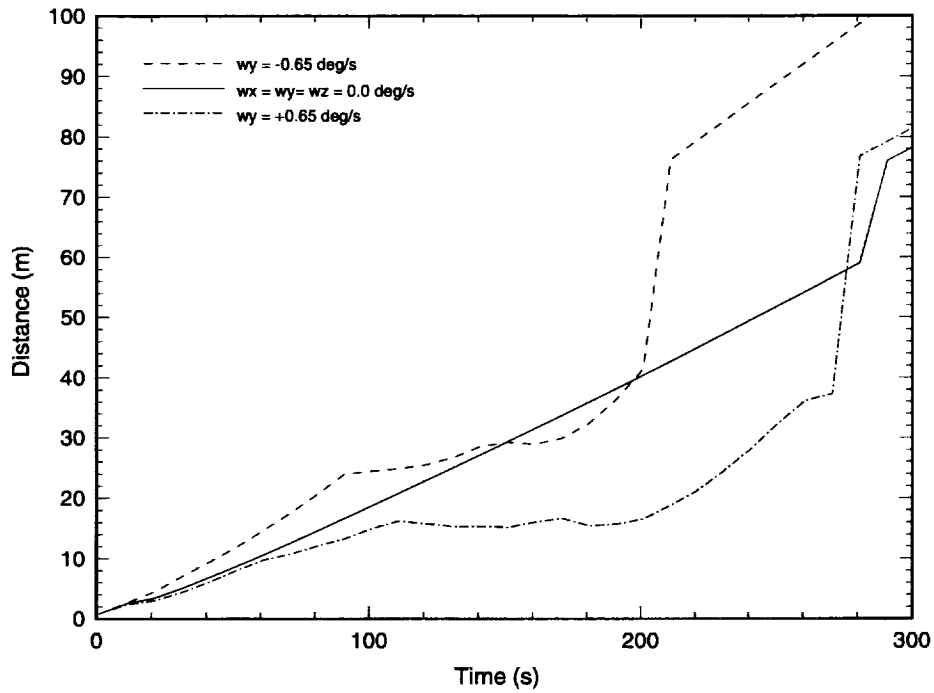

Figure 6.2.2-6: Minimum Distance Between ACRV and ISS  
 ISS  $\omega_y = \pm 0.65$  deg/s and ACRV  $\Delta V = 0.20$  m/s

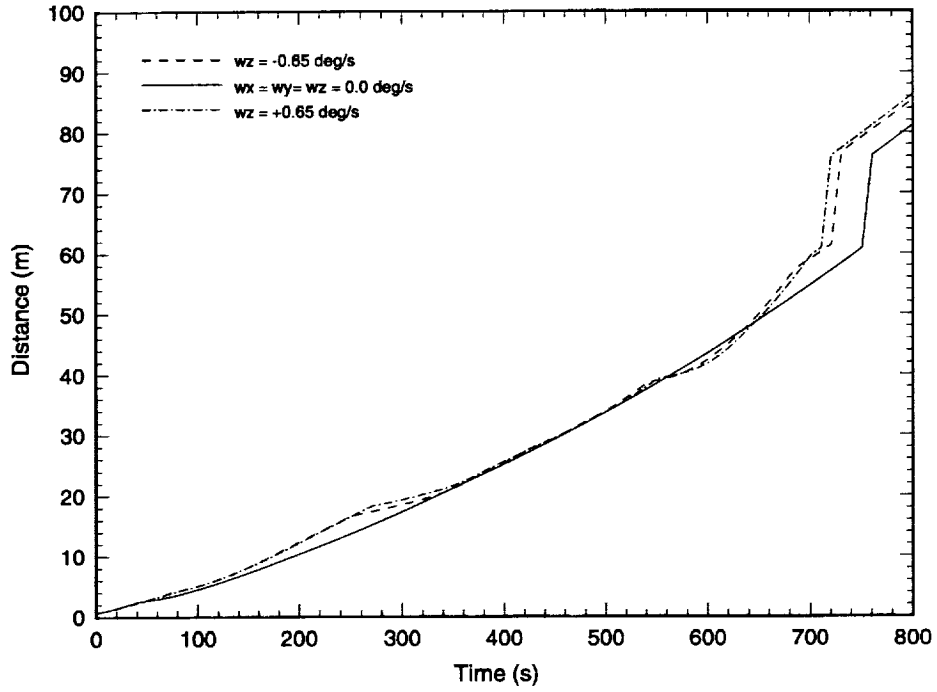

Figure 6.2.2-7: Minimum Distance Between ACRV and ISS  
ISS  $\omega_z = \pm 0.65 \text{ deg/s}$  and ACRV  $\Delta V = 0.05 \text{ m/s}$

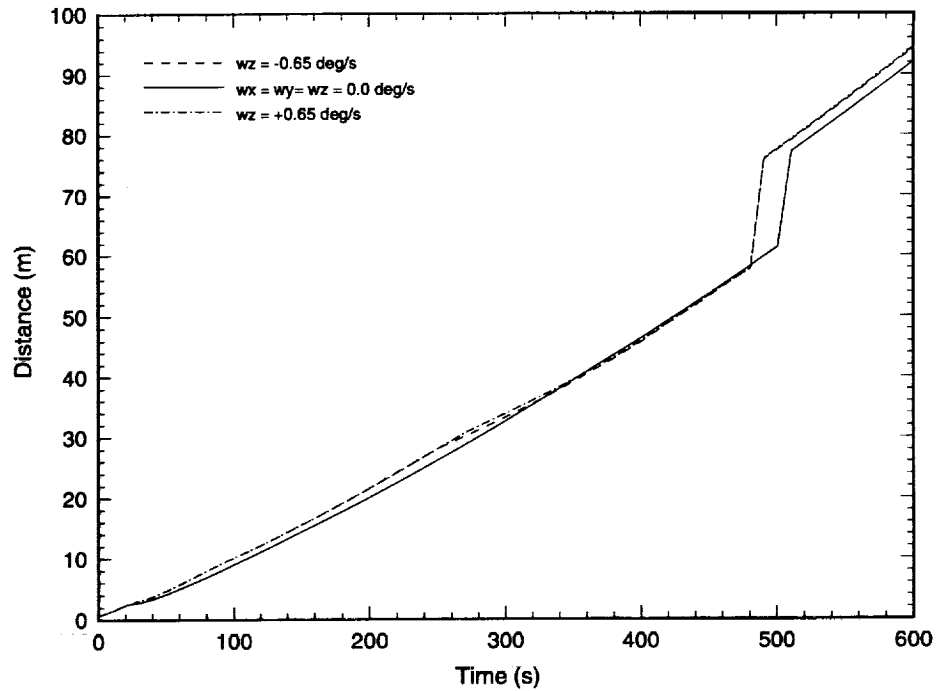

Figure 6.2.2-8: Minimum Distance Between ACRV and ISS  
ISS  $\omega_z = \pm 0.65 \text{ deg/s}$  and ACRV  $\Delta V = 0.10 \text{ m/s}$

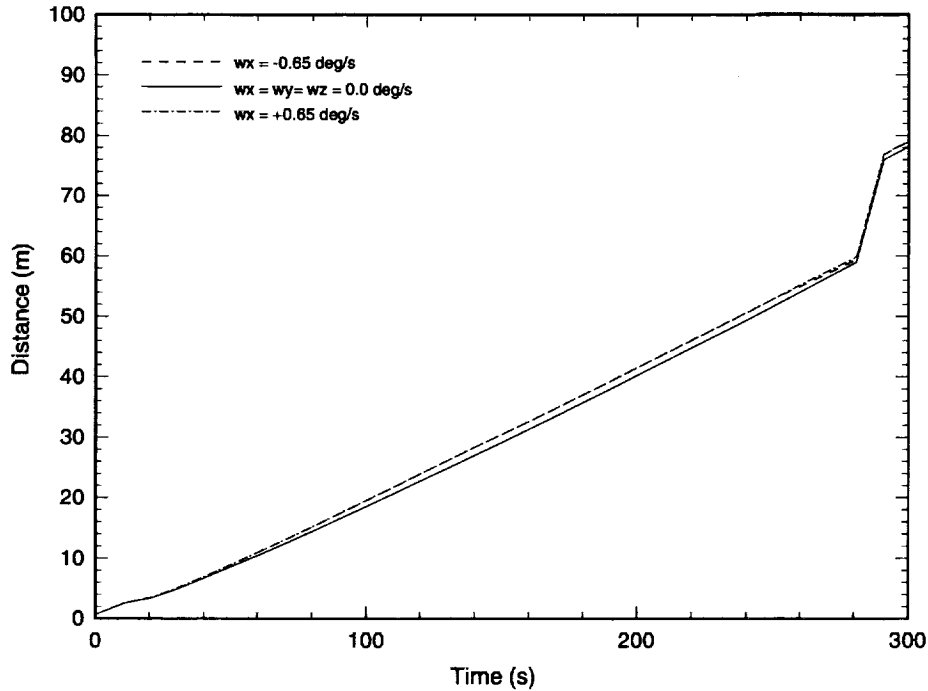

Figure 6.2.2-9: Minimum Distance Between ACRV and ISS  
ISS  $\omega_z = \pm 0.65$  deg/s and ACRV  $\Delta V = 0.20$  m/s

## 7.0 Assessment of ACRV Impacts on ISS

### 7.1 ISS Control Analysis

The plots in this section show the attitude history and attitudes rates for nominal ISS operations with the ACRV attached to the station, utilizing Control Moment Gyros (CMGs) for attitude control (See Figures 7.1-1 and 7.1-2). The analysis assumes that the ISS is orbiting at a 230 nautical mile altitude with a control design atmosphere ( $Flux_{10.7} = 230$ ,  $A_p = 140$ ). The ACRV has a negligible impact on the ISS attitude performance and the station attitude deviations are well within the acceptable limits. In a design atmosphere, the ISS with the ACRV has a TEA of -3.6,-11.6,0.8 (Yaw-Pitch-Roll) for normal CMG control and operational articular parts. Note that the control TEA differs from that used for the separation analysis. This is due to the assumption that the articular parts were locked at their initial orientations (alpha and beta angles equal to 0.0 degrees) for the separation analysis.

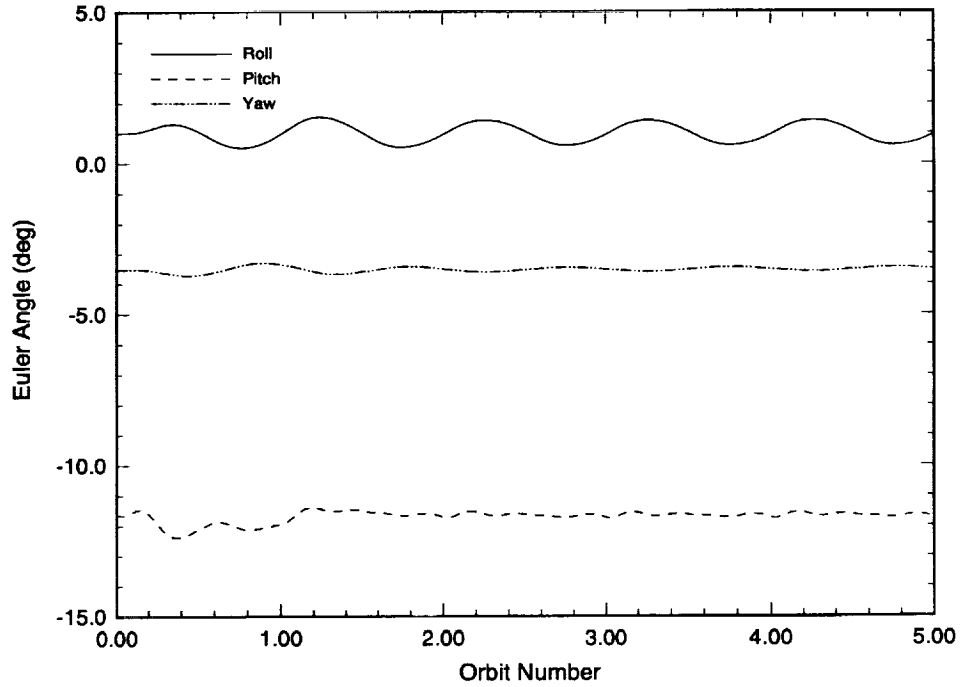

Figure 7.1-1: ISS with ACRV Attached - Nominal Operations Attitude History

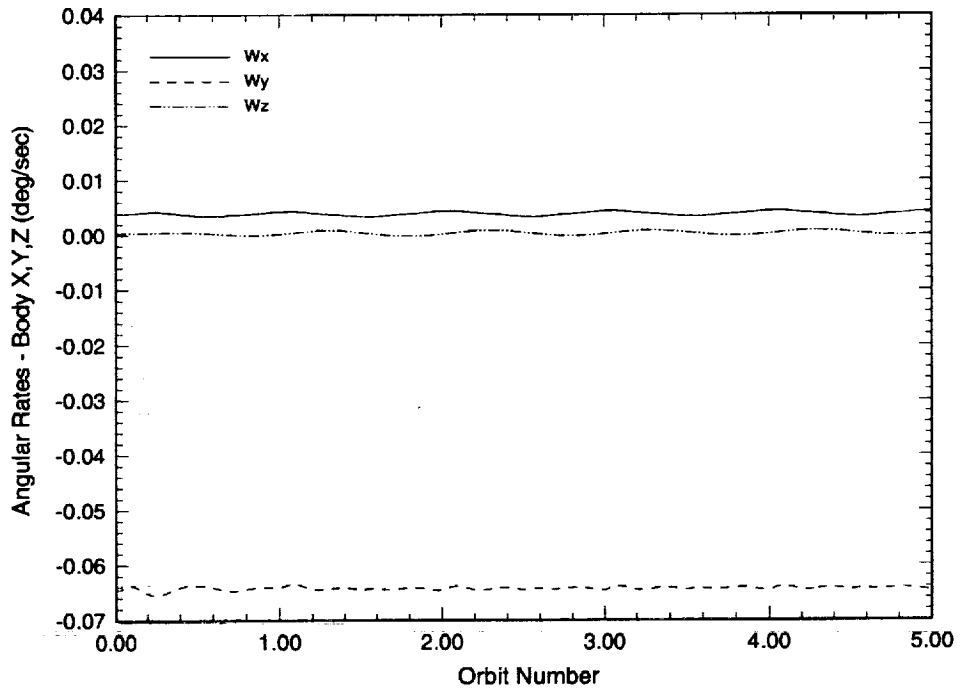

Figure 7.1-2: ISS with ACRV Attached - Nominal Operations Attitude Rates

## 7.2 ISS Microgravity Analysis

Figure 7.2-1 shows the impact of attaching the ACRV to the ISS on the one microgravity region. The effect is a negligible shift of the composite center of gravity along the positive body z-axis. Similar small shifts result for the higher microgravity regions as well. The microgravity analysis was performed assuming a 242.6 nmi altitude, a  $\text{Flux}_{10.7}$  of 191.5, and a geomagnetic index of 22.1. The altitude and atmosphere assumed for the microgravity analysis reflect nominal operating conditions anticipated for the Assembly Complete ISS. The TEA for the ISS with or without the ACRV was nearly identical for the above conditions, and was approximately -3.7, -10.2, 0.9 degrees (Yaw-Pitch-Roll).

## 7.3 ISS Resource Utilities

Current data indicates that locating the ACRV on the nadir port of the U.S. HAB module provides the necessary resource requirements to support the ACRV. A complete top level assessment of the resource requirements is discussed in Ref. 1. As ACRV systems requirements become better defined, additional in-depth ISS resource studies will need to be performed, which are beyond the scope of this report.

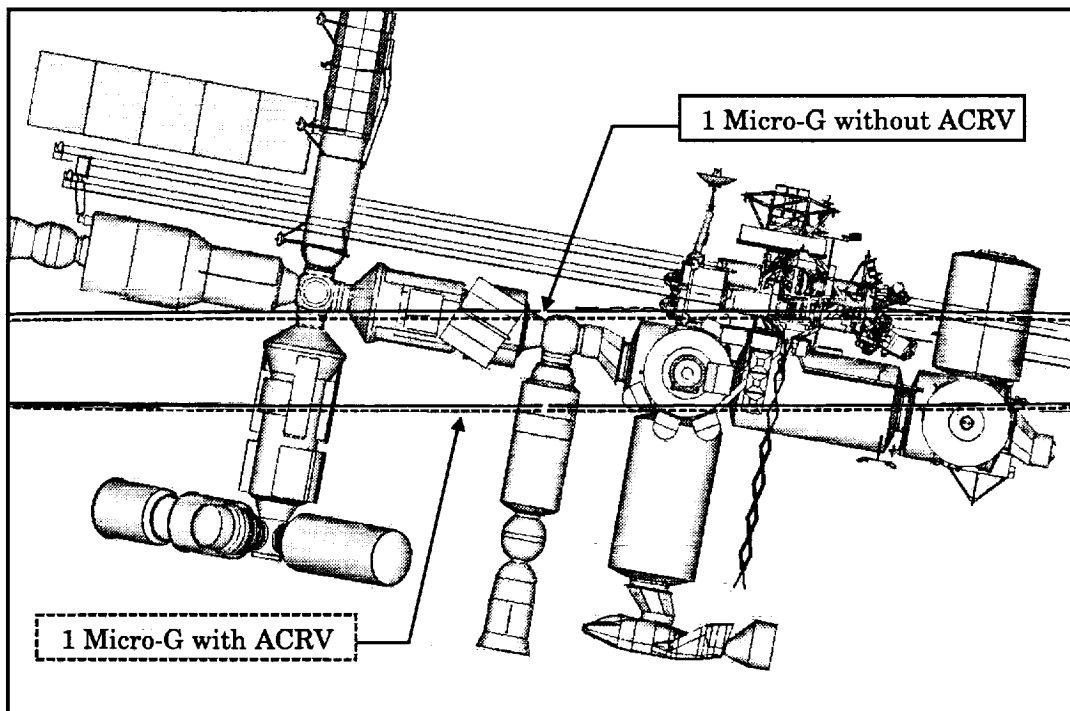

Figure 7.2-1: ACRV Impact on ISS One Microgravity Region

## **8.0 Conclusions/Summary**

This study has examined the installation of a single six person Assured Crew Return Vehicle on the International Space Station, and the ACRV separation trajectories under "worst case" ISS angular rates for ACRV departure velocities of 0.05, 0.10, and 0.20 m/s.

The installation and swap-out of the ACRV can be accomplished kinematically using the current baseline Orbiter bay location (the aft location discussed previously) for the ACRV. One grapple fixture must be located on the modified PMA and the other on the transition section. This means that during swap-out each ACRV requires a modified PMA. There is room in the orbiter bay for a Spacehab module when the ACRV is located in the aft position but clearance envelopes are violated. A second option is to move the ACRV forward 40.5 inches in the cargo bay allowing the SSRMS to reach a grapple fixture located on the port side of the transition section. The second grapple fixture would be located on the starboard side of the transition section. This eliminates the need for the second PMA but precludes a Spacehab being launched on the same flight. In addition, the Orbiter composite C.G. location is slightly forward of the forward No Deploy C.G. limit when the ACRV is in this forward position. This small negative margin should be easily corrected with the addition of proper ballast.

The separation analysis performed indicates that for ACRV departure velocities of 0.20 m/s or greater, an ACRV separating from a modified PMA on the nadir end of the U.S. HAB module has sufficient velocity to safely depart from the ISS, even under "worst case" station angular rates. For an ACRV  $\Delta V$  of 0.10 m/s or less, and an ISS angular rate offset of +/- 0.65 deg/s applied to the station body x-axis, the potential for recontact occurs. As the failure modes for ISS with respect to attitude performance are determined, further in-depth simulations will need to be performed to verify that the ACRV is capable of safely separating for the ISS in all potential contingency situations. If required for future detailed analyses, the ADASS software can perform complete separation simulations utilizing a computer model of the ACRV attitude control system, modeling the additional separation velocity supplied by the GN<sub>2</sub> RCS thruster system and characterizing the rotational effects on separation due to ACRV tip-off rates.

The impact of the ACRV on the ISS with respect to control attitude performance and microgravity is negligible. The space station will have to provide the resources to sustain the ACRV for the duration of its on-orbit stay time. As the design of the ACRV becomes more defined, resource allocation issues will need to be studied in depth.

REPORT DOCUMENTATION PAGE			Form Approved OMB No. 0704-0188	
Public reporting burden for this collection of information is estimated to average 1 hour per response, including the time for reviewing instructions, searching existing data sources, gathering and maintaining the data needed, and completing and reviewing the collection of information. Send comments regarding this burden estimate or any other aspect of this collection of information, including suggestions for reducing this burden, to Washington Headquarters Services, Directorate for Information Operations and Reports, 1215 Jefferson Davis Highway, Suite 1204, Arlington, VA 22202-4302, and to the Office of Management and Budget, Paperwork Reduction Project (0704-0188), Washington, DC 20503.				
1. AGENCY USE ONLY (Leave blank)	2. REPORT DATE December 1997	3. REPORT TYPE AND DATES COVERED Technical Memorandum		
4. TITLE AND SUBTITLE International Space Station (ISS) Accommodation of a Single U.S. Assured Crew Return Vehicle (ACRV)			5. FUNDING NUMBERS 906-43-00-01	
6. AUTHOR(S) Daniel D. Mazanek, Michelle A. Garn, Patrick A. Troutman Yuan Wang, Renjith R. Kumar, and Michael L. Heck				
7. PERFORMING ORGANIZATION NAME(S) AND ADDRESS(ES) NASA Langley Research Center Hampton, VA 23681-2199			8. PERFORMING ORGANIZATION REPORT NUMBER L-17683	
9. SPONSORING/MONITORING AGENCY NAME(S) AND ADDRESS(ES) National Aeronautics and Space Administration Washington, DC 20546-0001			10. SPONSORING/MONITORING AGENCY REPORT NUMBER NASA/TM-97-206272	
11. SUPPLEMENTARY NOTES				
12a. DISTRIBUTION/AVAILABILITY STATEMENT Unclassified-Unlimited Subject Category 15 Distribution: Nonstandard Availability: NASA CASI (301) 621-0390			12b. DISTRIBUTION CODE	
13. ABSTRACT (Maximum 200 words) The following report was generated to give the International Space Station (ISS) Program some additional insight into the operations and issues associated with accommodating a single U.S. developed Assured Crew Return Vehicle (ACRV). During the generation of this report, changes in both the ISS and ACRV programs were factored into the analysis with the realization that most of the work performed will eventually need to be repeated once the two programs become more integrated. No significant issues associated with the ISS accommodating the ACRV were uncovered. Kinematic analysis of ACRV installation showed that there are viable methods of using Shuttle and Station robotic manipulators. Separation analysis demonstrated that the ACRV departure path clears the Station structure for all likely contingency scenarios. The payload bay packaging analysis identified trades that can be made between payload bay location, Shuttle Remote Manipulator System (SRMS) reach and eventual designs of de-orbit stages and docking adapters.				
14. SUBJECT TERMS International Space Station (ISS), Assured Crew Return Vehicle (ACRV), Space Shuttle, robotic installation, separation trajectory			15. NUMBER OF PAGES 55	
			16. PRICE CODE AO4	
17. SECURITY CLASSIFICATION OF REPORT Unclassified	18. SECURITY CLASSIFICATION OF THIS PAGE Unclassified	19. SECURITY CLASSIFICATION OF ABSTRACT Unclassified	20. LIMITATION OF ABSTRACT	

## **9.0 References**

1. Piatek, Irene M., "International Space Station/Crew Return Vehicle Interface Final Report", JSC, November 1995.
2. "International Space Station On-Orbit Assembly, Modeling, and Mass Properties Databook - DAC #4 Preliminary Rev. B Assembly Sequence", JSC-26557, Rev. F, Volume I, June, 1996.