

ELECTRICAL POWER SYSTEMS FOR NASA'S SPACE TRANSPORTATION PROGRAM

Louis F. Lollar
NASA/Marshall Space Flight Center
Preliminary Design Office/PD11
Huntsville, AL 35812
(256)544-3306
(256)544-4225
Louis.Lollar@msfc.nasa.gov

Louis C. Maus
NASA/Marshall Space Flight Center
Preliminary Design Office/PD11
Huntsville, AL 35812
(256)544-0484
(256)544-4225
lou.maus@msfc.nasa.gov

ABSTRACT

Marshall Space Flight Center (MSFC) is the National Aeronautics and Space Administration's (NASA) lead center for space transportation systems development. These systems include earth to orbit launch vehicles, as well as vehicles for orbital transfer and deep space missions. The tasks for these systems include research, technology maturation, design, development, and integration of space transportation and propulsion systems.

One of the key elements in any transportation system is the electrical power system (EPS). Every transportation system has to have some form of electrical power and the EPS for each of these systems tends to be as varied and unique as the missions they are supporting.

The Preliminary Design Office (PD) at MSFC is tasked to perform feasibility analyses and preliminary design studies for new projects, particularly in the space transportation systems area. All major subsystems, including electrical power, are included in each of these studies. Three example systems being evaluated in PD at this time are the Liquid Fly Back Booster (LFBB) system, the Human Mission to Mars (HMM) study, and a tether based flight experiment called the Propulsive Small Expendable Deployer System (ProSEDS). These three systems are in various stages of definition in the study phase.

The goal of this paper is to describe the goals, missions, and system requirements of each project and then to focus on the unique EPS requirements that flow down for each of the three projects. Finally, we will discuss potential new EPS technologies that could be used to better meet the project requirements.

I. BACKGROUND

Marshall Space Flight Center (MSFC) is the National Aeronautics and Space Administration's (NASA) lead center for space transportation systems development. These systems include earth to orbit launch vehicles, as well as vehicles for orbital transfer and deep space missions. The tasks for these systems include research, technology maturation, design, development, and integration of space transportation and propulsion systems.

The Preliminary Design Office (PD) at MSFC is tasked to perform feasibility analyses and preliminary design studies for new projects, particularly in the space transportation systems area. All major subsystems, including electrical power, are included in each of these studies. The final study reports for these projects are costed, scheduled, and then presented to the customer for possible follow-on funding. A few projects that have passed through PD have been the Hubble Space Telescope, the Advanced X-ray Astrophysics Facility, and the

redesigned International Space Station (ISS).

II. INTRODUCTION

The Preliminary Design Office at MSFC is investigating over twenty-five projects at this time. One can group these projects into various themes. For example, one theme could be "airplanes in space" which would include the liquid fly back booster (LFBB) and the single stage to orbit rocket based combined cycle (RBCC) projects. Another theme could be "transportation to the planets" which would include the Mars sample return mission and the human mission to Mars (HMM) studies. Another theme might be "tethers for transportation" which would include the many boost/deboost tether projects for the ISS and Mir, plus the propulsive small expendable deployer system (ProSEDS) flight experiment.

One of the key elements in all of these projects is the electrical power system. Each one of these projects has to have some form of electrical power and the EPS for each of these systems tends to be as varied and unique as the missions they are supporting. To view as many EPS requirements as possible, three example projects currently being evaluated in PD will be reported. These are the LFBB, the HMM, and the ProSEDS. The goal of this paper is to describe the goals, missions, and system requirements of each project and then to focus on the unique EPS requirements that flow down from each project.

III. THE LIQUID FLY BACK BOOSTER

A. Overview

The concept of retrieving the first stage booster of a multi-stage rocket system has been around since early in the Space Shuttle program. Requirements and funding levels changed which led to the recoverable solid rocket booster concept presently being used in the Space Transportation System (STS).

Since then, partially as a result of the Challenger accident, various replacement options for the solid rocket boosters have been studied. Some of these studies have resulted in the redesigned solid rocket motor (RSRM) system now flying, yet none of the more ambitious redesigns have been implemented. A 1993 study¹ concluded that from a life cycle cost and safety improvement perspective, the most competitive booster design would use liquid rocket engines and be fully recoverable by flying back to the launch site.

In 1994, a NASA study team representing Johnson Space Center (JSC), Kennedy Space Center (KSC), and MSFC performed a pre-phase A study assessment on a LFBB.² In 1996, MSFC, along with the Boeing Company and Lockheed-Martin, began a feasibility and cost study into using the LFBB as a phase IV upgrade to the STS. One of the primary goals of this study is to develop a set of level I design requirements. The EPS design concepts are derived from this study's design requirements.

B. Mission Groundrules and Requirements

In order to bound the design space, several groundrules were established for the LFBB. The first groundrule was that the boosters would be designed for use in the STS, therefore Orbiter, External Tank (ET), and launch and processing facilities modifications must be minimized. Next, launch loads, maximum Q points, mission requirements, and environmental impacts would be better or no worse than the present STS levels. Finally, all LFBB designs will focus on lowering the operations and processing costs as much as possible.

Based on these groundrules and other derived requirements, the following basic concept has emerged. At T - TBD(few) seconds, the three Space Shuttle Main Engines (SSME) explode into life. Shortly thereafter, the eight to ten liquid booster engines fire. Now, unlike the RSRM's, if an engine problem occurs, the system could be shut down or launched

into a known, safe trajectory. If all systems are operating nominally, the STS operates almost the same as it does now which includes ascent guidance and control being governed by the orbiter. At approximately T+2.5 minutes, 150,000 feet, 31 nautical miles(NM) downrange, and 5500 feet per second, the LFBB separates from the orbiter and ET. The boosters coast to an apogee of approximately 260,000 feet and 100 NM downrange while all deployables (wings, canards, etc.) deploy. The boosters coast at a 40 degrees angle of attack and perform a large bank turn towards the launch site. At about T + 8 minutes, 31,000 feet, and 215 NM downrange, the air breathing engines(ABEs) perform a cold start and the boosters autonomously fly back to the KSC landing strip where they complete a safe autoland at approximately T + 52 minutes. The boosters are then rolled back to a processing area to be prepared for

integration into the STS for the next flight.

C. EPS System Requirements

The basic requirements for the EPS combine the redundancy and reliability requirements of a spacecraft EPS with the maintainability requirements of an aircraft EPS. During ascent, the LFBB EPS will have to provide power to the LFBB engine controllers and avionics as well as interface with the orbiter's EPS. After separation, LFBB control functions reverts to its own avionics suite with the energy being supplied by its own space qualified power source. After reentry, the bank turn, and the ABEs cold start, the EPS can now obtain energy from a power take-off on the ABEs. After landing and the ABEs shut down, the EPS will provide any power needed for vehicle health monitoring (VHM) until the ground support equipment arrives.

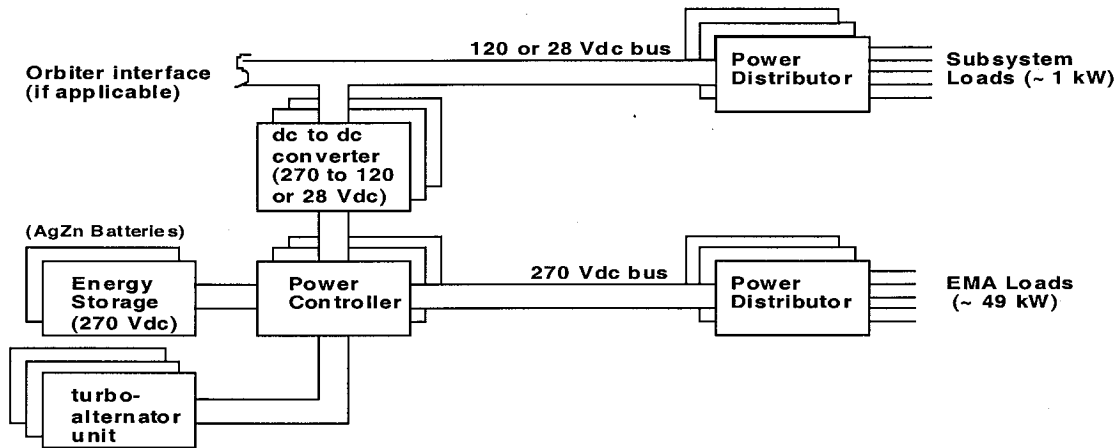

Figure 1. Preliminary Electrical Power System For LFBB [One Booster]

A conceptual EPS design is shown in figure 1. The system is two fault tolerant with a 270 Vdc bus for the electromechanically based actuator systems loads and a 120 Vdc or 28 Vdc bus for the remaining avionics loads. The power sources include three 270 Vdc, 60 Ahr silver-zinc (AgZn) batteries and a turbo-alternator unit for each ABE. The power controller monitors and controls the flow of energy to the busses and the

power distributors provide protection and monitoring to each load. This proposed system should be versatile enough to handle the varied load and source power profiles of the LFBB, yet simple enough to be reliable and serviceable.

IV. ProSEDS

A. Introduction

The tether project, ProSEDS, is a continuing effort in the research and development of an electrodynamic tether system that has operational applications for future spacecraft scenarios and missions. Electrodynamic tethered flights of the recent past, such as the Tethered Satellite System (TSS-1 & -1R) and the Plasma Motor Generator (PMG) Experiment, has provided experimental data to further develop practical systems.

With conductive tethers, induced voltages were measured in both TSS-1 & -1R flights. In the TSS-1R flight, induced voltages in excess of 3 kV were measured in a 20 km length tethered system. The PMG experiment verified that tether current will flow in both directions which represented both the generator and motor modes of operation.

For future space based system, recent engineering studies have shown that practical implementation of conductive tethers can be achieved in the following applications: (1) electrical power generation, (2) orbital reboost of space based systems if excessive electrical power is available, and (3) deorbit payloads or space debris utilizing electrodynamic drag forces.

The ProSEDS mission will demonstrate continued development in the following areas: (1) deboost or deorbit a payload through the utilization of electrodynamic drag forces, (2) collect,

test and validate the current collecting capability of a "bare wire" tether which will enhance the current collecting capabilities, and (3) convert the electrical energy generated in the tether system into a more useable form.

B. The Space Plasma Environment

The basic or fundamental principle of the electrodynamic tether system is that a conductive wire tether cutting the earth's magnetic field will act like a generator and induce an emf into the conductor that will cause a current to flow in a closed loop. The magnitude of this induced emf ($v \times B \cdot L$) is a function of velocity (v), magnetic field strength (B), and tether length (L). These parameters are functions of the orbit definition (such as altitude and inclination), solar flux activity and time of year.

As defined by the ProSEDS mission, the payload will be a secondary payload on a Delta II upper stage. The orbit will be 400 km circular with an inclination of 32 degrees. Figure 2 depicts the predicted open circuit voltage induced into a 5 km conducting tether. From the graph, it can be seen that an average induced voltage of approximately 140 volts per kilometer can be expected. Peak voltages, however, can be as high as 200 volts per kilometer.

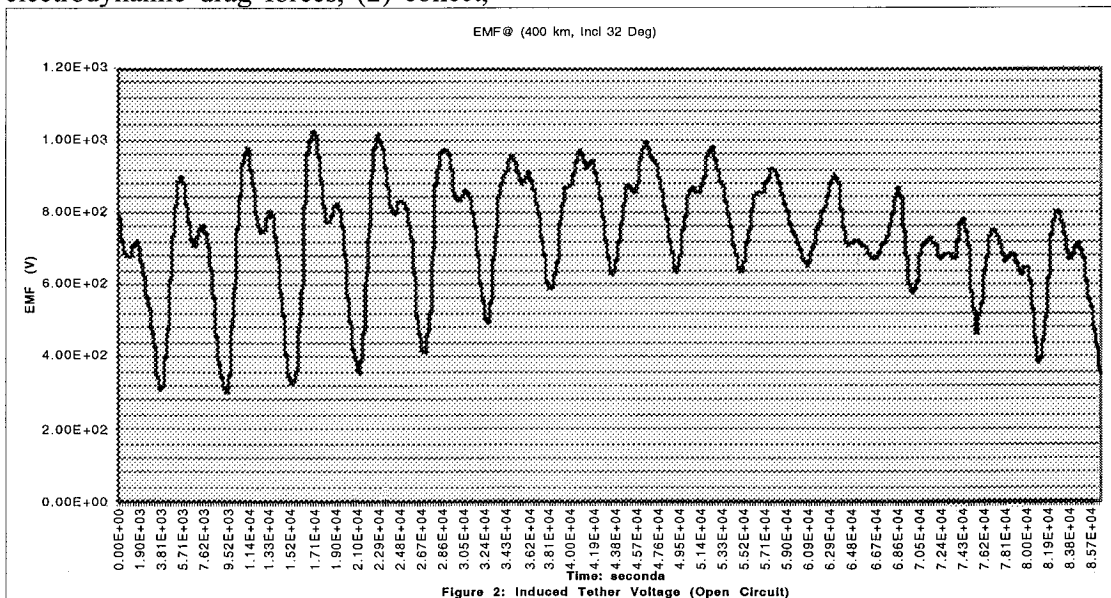

Figure 2: Induced Tether Voltage (Open Circuit)

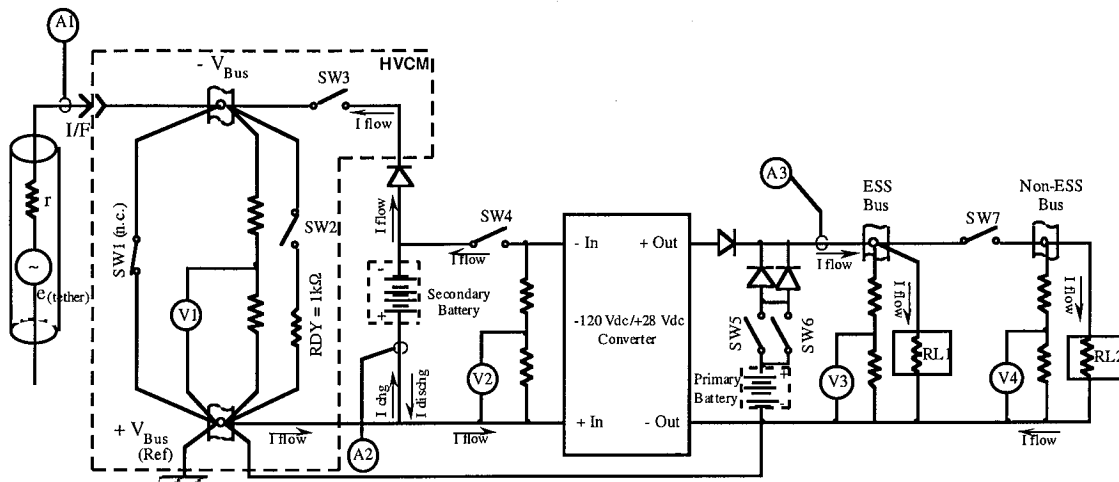

Figure 3. ProSEDS Electrical Power System

One of the more challenging aspects of the pre-mission phase is to predict the magnitude of the current flow through the “bare wire” tether system and through the plasma of the ionosphere. Within the constraints of the mission and the available hardware, peak orbital average currents of two amperes are anticipated. Peak current may be as high as 4.5 amperes.

C. The Electrical Power Subsystem

From a conceptual standpoint, one of the aspects of the ProSEDS mission, and subsequently the electrical power subsystem, is to collect data over at least three orbits. This will be accomplished with a primary battery sized for the deployment of the 20 km tether system plus the energy required for the loads during this minimum period of three orbits of data collection. Following this, the power source for the loads will be the tether system which will supply energy for secondary battery recharge and power conversion.

A secondary mission objective is to demonstrate the storage, conversion and regulation of the tethered-generated electrical power. The basic concept, shown in Figure 3, is to provide regulation and conversion of the very high induced tethered voltages for further conversion into a usable system voltage. Lacking a

high input voltage “buck” power converter, the input voltage to the converter is regulated using a low cost, secondary nickel-cadmium battery. This battery clamps a portion of the high input system voltage with the remaining voltage being dropped across the tether resistance, the impedance of the ionosphere, and the plasma contactor (not shown).

A group of front-end high voltage vacuum relays (SW1, SW2, SW3) are designed to operate in a sequence to measure parameters of the tether and of the ionosphere such as open circuit voltage, short circuit current, and characteristics at a specified resistive load. The recharge logic for the secondary battery will be controlled by relays SW3 and SW4.

V. HUMAN MISSION TO MARS

A. Overview

Working with the science and exploration community, NASA (MSFC, JSC, LeRC) is developing a design reference mission (DRM) to be used in a planning exercise to send humans to Mars during the 2011 and 2013/2014 Mars opportunities. The DRM represents the most current approaches to completing the mission and provides a baseline architecture to analyze new technology insertions.

B. Design Reference Mission

Beginning in 2011, two cargo flights will leave the Earth toward Mars on a low energy, long transit time trajectory. The first cargo flight containing a fully fueled Earth return vehicle will aerocapture into a Martian orbit. This vehicle which will eventually be used to bring back the crew and their samples will remain in the Martian orbit until the Mars exploration activities are completed. The second cargo flight will land on the Martian surface. Its cargo contains storage tanks, liquid hydrogen, an in-situ propellant production (ISPP) unit, and a nuclear surface power (NSP) unit. After landing, the NSP unit will deploy and begin supplying power to the ISPP unit. Thus, the ascent vehicle's propellant will be produced and stored on Mars before the crew has to commit to the long journey to Mars.

Then in 2014, a crew of six and their exploration equipment will depart for Mars along a more direct trajectory. After aerocapture into a Martian orbit, the crew and equipment will descend to the surface, landing near the previous cargo landing site. After 569 days on the Martian surface, the crew and sample material will ascend to and dock with the orbiting Earth return vehicle for the 154 day trip back home. [For more details, see references (3) and (4).]

C. Transportation and EPS Requirements of the DRM

The four major transportation elements of the DRM are the trans-Mars injection (TMI) stage, the descent/ascent stage to the Martian surface, the trans-Earth injection (TEI) stage, and the aerobrake elements. Of these four, only the first three will have some form of EPS.

The TMI stage is comprised of three nuclear thermal propulsion (NTP) engines providing a total thrust level of 200,000 Newtons. In order to reduce the delta-velocity budget, a TMI stage will stay in a low Earth orbit (LEO) for up to 32 days. This requirement will force the

TMI stage to have some form of power generation/energy storage EPS. Depending on the number of electromechanical actuators (EMAs) and rendezvous and docking avionics, the EPS could be in the 1000's of Watts. One alternative is to use the NTP engine as a power source in a bi-modal concept, but this would require the TMI stage to remain with the cargo stages until near Mars orbit.

The TEI stage, used to return the crew to Earth, will be similar to the TMI stage. The primary differences involve longer life (up to 4 years), power-hungry cryo-coolers to minimize boil-off, and multiple, long time between starts and engine firings. This requires the EPS to be highly reliable and to provide power to a larger payload than the TMI stage. In addition, the EPS has to operate in a Martian orbit which is much further from the Sun than an Earth orbit.

Finally, the descent/ascent stage EPS could be integrated with the overall EPS required to maintain life support for the crew.

VI. TECHNOLOGY NEEDS AND CONCLUSION

As we begin the 21st century, the EPS technology requirements for our space transportation systems will be as diverse as our people. From unmanned flying rockets to tethered spacecraft to visiting our nearest neighbor planet, the EPS design engineer will have to become more creative as high power, high reliability, and low mass become the driving requirements.

To meet these requirements, MSFC has been investigating the following technology areas. The Department of Defense's (DOD) "More Electric Transportation" initiatives are producing many new innovations in ruggedized power generators, electrical actuation and high power, high temperature electronics for power management and distribution systems. In the energy storage arena, flywheels and Lithium-Ion batteries appear to have tremendous potential in lowering the EPS mass through higher Watt-hours

per kilogram levels. New lightweight, low intensity solar cell technology, as well as clean, safe nuclear technology could help solve some of the challenges in sending humans to the Martian surface and/or more complex (read high power) unmanned probes to Mars and beyond. Other related technology areas such as micro-miniaturization, composite materials, and new thermal devices and materials are also being investigated for potential EPS applications.

MSFC still has more challenges than solutions as we attempt to provide safe, inexpensive, and reliable space transportation systems to the United States and the World. Thus, we will continue to seek out new and innovative technologies which can be used to help solve the many challenges of space travel.

ACKNOWLEDGMENTS (ProSEDS SECTION):

Thanks to Chris Rupp (PS04) Fred Elliott (EL22), Kai Hwang (CSC/MSFC).

REFERENCES

1. "Access to Space Option 1 Team Summary Report," JSC White Paper. August 31, 1993.
2. Peterson, W., et al, "Liquid Flyback Booster Pre-Phase A Study Assessment," NASA Technical Memorandum 104801. 1994.
3. Hoffman, Stephen J., "Human Exploration of Mars: the reference mission of the NASA Mars Exploration Study Team," NASA SP-6107. 1997.
4. Kos, Larry, "The Human Mars Mission: Transportation Assessment," 15th Symposium on Space Nuclear Power and Propulsion at the Space Technology and Applications International Forum. January 1998.