

SPACE STATION ENVIRONMENTAL CONTROL AND LIFE SUPPORT SYSTEMS:

AN UPDATE ON WASTE WATER RECLAMATION

Kathleen M. Ferner, Hamilton Standard Division of United Technologies Corporation

ABSTRACT

Since the mid-1980's, work has been ongoing in the development of the various environmental control and life support systems (ECLSS) for the space station. Part of this effort has been focused on the development of a new subsystem to reclaim waste water that had not been previously required for shuttle missions. Because of the extended manned missions proposed, reclamation of waste water becomes imperative to avoid the weight penalties associated with resupplying a crew's entire water needs for consumption and daily hygiene. Hamilton Standard, under contract to Boeing Aerospace and Electronics, has been designing the water reclamation system for space station use. Since June of 1991, Hamilton Standard has developed a combined water processor capable of reclaiming potable quality water from waste hygiene water, used laundry water, processed urine, Shuttle fuel cell water, humidity condensate and other minor waste water sources. The system was assembled and then tested with over 27,700 pounds of "real" waste water. During the 1700 hours of system operation required to process this waste water, potable quality water meeting NASA and Boeing specifications was produced. This paper gives a schematic overview of the system, describes the test conditions and test results and outlines the next steps for system development.

INTRODUCTION

The Predevelopment Water Processor is the result of a maturation process that was begun with the design, assembly and testing of the Predevelopment Potable Water Processor by Hamilton Standard. That system performed successfully in both Hamilton Standard and NASA tests during 1991. Since that time, the Predevelopment Water Processor was run in excess of 1100 hours during design support testing and in excess of 650 hours during in-process/acceptance testing. During the 1700 hours of system operation, the various performance aspects of the

system were verified, using as a baseline the information, procedures and lessons learned from previous Hamilton Standard, Boeing and NASA tests. During design support, in-process and acceptance testing, many test objectives were satisfied and are discussed in this paper. They include the verification of the processed water microbial activity; the verification of the chemical performance of the system in several areas, including iodine concentration, ph, total carbon and total organic carbon concentration, and water conductivity; and verification of expendable component life. One final objective, and perhaps the most important, was also satisfied as a result of this test program, human taste testing of the processed water.

The purpose of this paper is to acquaint the reader with the Predevelopment Water Processor test program, the system schematic and the test results obtained during the 1700 hours of system operation.

TEST PROGRAM OVERVIEW

The purpose of the Predevelopment Water Processor Testing was to gain maximum experience in system operation. Provisions for testing the system 24 hours per day, 7 days per week, were made. Through this testing, data was gathered on overall system performance and on individual component performance. The data was used to optimize the Predevelopment Water Processor (PDWP) prior to delivery to Boeing and as an input to the design process for the flight hardware.

Two phases of testing were conducted: design support testing (DST) of the PDWP containing "engineering" hardware and in-process/acceptance testing (IPT/AT) of the deliverable system prior to Boeing acceptance of the unit. Both test phases were performed using the same system components in an identical schematic orientation. The only hardware differences were the use of some temporary tubing runs and insulation during the DST phase. Additionally, clear

lexan housings for the particulate filter and multifiltration (MF) beds were used during DST to allow visual observations. The system was run automatically via computer control. Software controlled all system functions, including heater cycling, pump control, compressor control, and all solenoid valves with the exception of the reject valve, which was positioned by the test operator based on conductivity and pH readings.

System performance data was obtained by two methods:

1. Instrumentation.
2. Chemical and microbial analyses of water samples.

All system instrumentation was recorded with data logging to disk and printer hard copy. The types and locations of system instrumentation are described in the schematic overview, below. Other methods for obtaining system performance data were through the chemical and microbiological analyses of water samples, obtained through six sterile sampling ports located throughout the system. Water samples were drawn from these ports twice per day and analyzed for pH, conductivity, iodine, organics, inorganics, total carbon, total organic carbon and microbial concentration. All test results were recorded on log sheets developed specifically for the test program. Upon completion of the tests, all data collected was analyzed and provided the basis for the acceptance of the Predevelopment Water Processor by Boeing.

SCHEMATIC OVERVIEW

As mentioned previously, minor hardware differences existed between the system when DST and IPT/AT were performed. However, these differences did not alter the system schematic. Figure 1 shows the system block diagram. Up to 300 pounds of unprocessed water were stored in the waste tanks. Waste water storage was achieved through the use of two 150 pound capacity bellows tanks. The pump assembly drew the contaminated water from these tanks into the processor. The first step in the reclamation process was the filtration of the waste water through the use of a 0.5 micron depth filter. The water was then sterilized to kill bacteria. This was achieved by a sterilizer that heated the water and maintained it at a minimum of 250 degrees F for an average of 40 minutes. Per Figure 1, this step was implemented through the use of a regenerative heat exchanger and the sterilizer with two surface mounted blanket heaters. The water was first warmed to an intermediate temperature of 210 degrees F by flowing through the heat exchanger and then was brought up to 250 degrees F in the preheat zone of the sterilizer.

After sterilization, the water was exposed to three chemical decontamination processes. The first occurred in a

multifiltration bed that removed various chemical contaminants through the use of activated carbons and ion exchange resins. Contaminants removed at this stage included the shower and laundry soaps, other organic material, trace metals and salts. As shown in Figure 1, two identical MF beds were present within the system. After the first was expended, the second was indexed into the first position, and a new one was installed into the second position. Each MF bed was composed of several ion exchange resins and activated carbons layered in a specific order to maximize contaminant removal efficiency.

When the water exited the MF beds, the only remaining contaminants were the low molecular weight volatile organics. These were removed through the use of a volatile removal apparatus (VRA). In this processing step, the water was once again heated by flowing through a regenerative heat exchanger and a heater, so that it entered the VRA at elevated temperature. Within the VRA, the volatile organics were oxidized, and by-products were formed that were easily removed during subsequent processing steps. The water exiting the VRA was cooled when it flowed through the regenerative heat exchanger.

By-products requiring removal from the water after processing in the VRA included acetic and propanoic (also referred to as propionic) acids, carbonates, gaseous carbon dioxide and oxygen. The resultant gases were removed first through the use of a static membrane phase separator. The acids and carbonates were removed through the use of another multifiltration bed with resins selected especially for removing the chemical by-products of the VRA's reaction. The last resin contained within this bed was iodinated and was designed to impart 1 to 4 ppm iodine into the processed water stream to inhibit the growth of bacteria during storage.

After processing, the water flowed through pH and conductivity sensors. Based on these sensor readings, the system operator directed acceptable water to the product water storage tanks by the appropriate positioning of the reject valve. Product water was stored in two 150 pound capacity bellows tanks, identical to the waste water tanks. If the processed water did not meet pH and conductivity criteria, the three-way valve was placed in the reject position, so that the water could undergo further processing. This further processing entailed dosing the rejected water with more iodine and then returning it to the beginning of the reclamation process.

During both DST and IPT/AT, the system was run under complete software control through the use of instrumentation that was monitored to determine system health. Instrumentation critical to monitoring system health and important to DST and IPT/AT is shown in Figure 1 and described below.

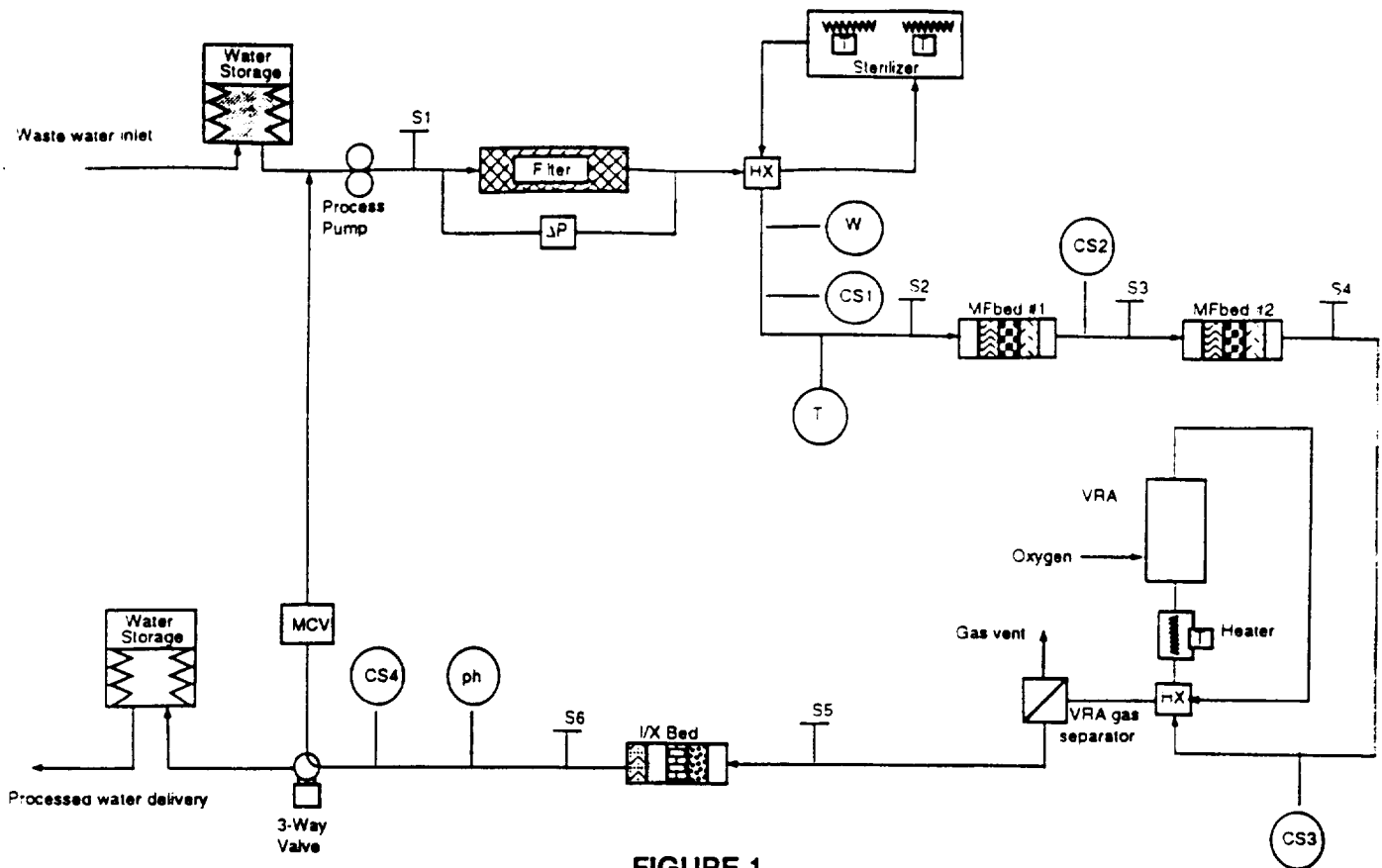

FIGURE 1

The first critical sensor was the delta-pressure sensor located on the filter. When the pressure reached 15 psid, the software sent a message to the test operator to replace the filter. The second system critical sensor shown in Figure 1 was the flow meter located downstream of the sterilizer/regenerative heat exchanger combination. This sensor was used to control the feed pump speed so that an average water flow of 16 pounds/hour was maintained. Conductivity sensors were extremely important for assessing the performance of the PDWP. Four of them were present within the system. The first, located upstream of the first MF bed was used to monitor the conductivity of the waste water. The second conductivity sensor, located between the two MF beds, monitored the conductivity of the water after treatment. The importance of these two sensors can be seen by examining the ratio $CS2/CS1$. When this ratio was greater than/equal to 0.9, the MF bed was defined as fully expended, and an index and replace operation (as described earlier) was initiated. The third conductivity sensor was used to verify that no breakthrough of the second MF bed occurred during processing. Lastly, the fourth conductivity sensor was used in conjunction with the ph sensor by the system test operator in determining the acceptability of the processed water. Temperature sensors, located throughout the system, were used for controlling heater on/off cycles and monitoring water temperatures of water flowing into temperature sensitive components.

The last significant feature of the schematic block

diagram shown in Figure 1 was the sampling ports located throughout the system. It was through these six ports that water samples were drawn twice daily for the various chemical and microbial evaluations performed to monitor system performance. Sample port S1 enabled the drawing of waste water samples for the characterization of total carbon (TC), total organic carbon (TOC) and, therefore, a determination of total inorganic carbon (TIC), ph, conductivity and turbidity. These chemical characterizations were performed on water drawn from every sample port installed in the system. Additionally, at sample port S3, analyses for sodium, ammonium, potassium, chloride, fluoride, phosphate and sulfate were performed. By performing these additional analyses, MF bed performance and life characteristics were monitored. At sample port S5, the water samples were also analyzed for the concentrations of acetic and propanoic acids present. This data was used to gauge the performance of the VRA. Lastly, water drawn from sample port S6 was additionally analyzed for iodine concentration. It should be noted that as processed water was drained from the product tanks, chemical samples were taken, and the same analyses as performed at S6 were performed.

Besides chemical analyses performed on samples drawn from ports S1 through S6, microbial characterizations were also performed. Sample ports S4, S5 and S6 and the product water tanks were monitored twice daily for microbial activity.

TEST OBJECTIVES AND PROCEDURES

Several objectives were satisfied as a result of the design support, in-process and acceptance testing performed on the PDWP during 1992. The first was proving the system design by producing potable quality water using a "real" waste water stream. By running the system for 1110 hours during DST and 655 hours during IPT/AT, Hamilton Standard was able to gather data on both system and component performance. This information will be used to optimize the design of the flight water processor.

Test Procedures:

The waste water for the Space Station Water Processor will include shower and handwash water, laundry water, processed urine, humidity condensate, oral hygiene water, and periodically fuel cell water. For design support testing, the waste water was generally composed of 9% processed urine pretreated with oxone and sulfuric acid prior to distillation, 63% laundry water containing sodiumdodecyl benzene sulfonate (SDBS) soap, and 28% shower water containing igepon soap. For the last week of DST, the waste water baseline was changed to include oral hygiene water and ersatz humidity condensate. The waste water model was then:

- 16% - 20% shower water,
- 63% - 70% laundry water,
- 3% - 6% urine distillate with hypochlorite pretreatment (Clorox bleach),
- 0.5% - 2% oral hygiene water,
- 8% - 14% ersatz humidity condensate.

For IPT/AT, the waste stream was not altered in any way during the course of the test. Each batch of waste water mixed was comprised of:

- 55% laundry water,
- 27% shower water,
- 12% ersatz humidity condensate,
- 6% urine distillate.

For both DST and IPT/AT, many protocols were established for the generation, collection and storage of waste waters, namely, shower, laundry and urine. Each of the protocols is discussed below.

Shower Water:

Hamilton Standard employee volunteers showered daily in the shower facility specifically set up for generating waste water. Each volunteer rode an exercise bicycle for 10 - 15 minutes to build up a sweat. The volunteer then showered

with 1.5 gallons of water and 5.1 grams of igepon soap. This quantity of water was used to simulate a daily water utilization of one approximately eight-pound shower and four one-pound hand washes per person. The 5.1 grams of soap represented the total quantity for the shower and hand washes. A container was plumbed to the shower outlet to facilitate collection of the waste water. After collection, the water was filtered to 100 microns and then stored at room temperature for mixing with the other waste water constituents. The igepon, baselined for space station hygiene uses, is comprised of the following:

98.75%	igepon TC-42,
.75%	luviquat,
0.5%	lecthycin.

All volunteers used all of the water and soap allotted for each shower. Additionally, great care was taken to isolate the cleaning agents used within the shower facility so that PDWP performance results were not impacted.

Urine:

Urine was collected and processed in batches. When 1 batch of urine, defined as 12 liters, was obtained from volunteers, it was pretreated to inhibit bacteria growth. The urine was pretreated with a solution of 27.6 grams of sulfuric acid in 75 cc of water, 60 grams of oxone and 4 liters of distilled water. The distilled water simulated flush water. This pretreatment step yielded approximately 16 liters of fluid. Upon completion of pretreatment, the fluid was then distilled using a vacuum distillation rig. The distilled fluid was collected and stored for mixing into the combined waste water stream. Part way through system testing, an investigation was launched into alternate pretreatment methods. At that time, the oxone pretreat was replaced with a bleach pretreat. In this method, 1 ml of bleach was added to the collection container after each urination. When 12 liters of urine were collected, 27.6 gm of sulfuric acid mixed with 75 cc of water was added to the urine. Distilled water was added to this urine/pretreat mixture to obtain 16 liters of fluid. The urine solution was then distilled and the distillate saved for combination with the other waste sources. Upon the urine pretreatment protocol change, no system performance effects were noted.

Laundry Water:

The waste laundry water was obtained from three different types of laundry loads. A load of laundry was comprised of 5 pounds of dry items. This translated into 16 t-shirts, 4 jumpsuits or 8 towels. The towels were obtained on a daily basis after use by the shower volunteers in the shower facility. The jumpsuits and t-shirts were obtained from two additional groups of volunteers. The t-shirts were provided on a daily basis in the locker rooms and were worn by lunch-time runners. After use by these people, they were

collected and washed. The jumpsuits were worn by employee volunteers within Hamilton Standard facilities during working hours. These volunteers were screened so that greasy/grimy dirt would not soil these jumpsuits. At the end of the day, the jumpsuits were collected and laundered. The washing machine water outlet was set up so that water exiting the machine was diverted from the drain into a collection container. Each 5 lb load of laundry was washed with 2 grams of Stepan Blosoft S-100 containing the active ingredient sodium dodecyl benzene sulfonate, SDBS. Approximately 15 gallons of water was used to wash each load of laundry. The first 6 gallons dumped were collected, filtered to 100 microns and then mixed with the other waste water constituents. The remaining 9 gallons of laundry water was dumped to the facility drain. A chemical analysis of the water saved for processing showed that only 25% of the SDBS was collected in the first 6 gallons. Subsequently, the laundry protocol was changed so that a greater soap challenge was created in the laundry water. This was achieved by using the same quantity of SDBS, collecting the first 6 gallons of wash water for mixing with other waste water constituents, and then collecting the second 6 gallons of wash water for use as the initial wash water used for the next load of laundry. Through this protocol, 50% of the SDBS was collected with the waste water. In both instances, the laundry water collected was filtered to 100 microns and then stored for later use.

MICROBIOLOGICAL RESULTS

For reclaimed potable quality water, NASA's specified limit for microbial activity is ≤ 1 CFU/100 ml. Throughout the testing, the PDWP generally produced water meeting this specification. At times, however, microbial readings jumped to levels of 2 to 3 CFU/100 ml with instances of higher readings where the sampling technique was called into question. In each of these non-suspect instances, the cause of the outage was biofilm that flaked off of upstream tubing runs and made its way into product water storage. In all of these instances, the iodine imparted by the ion exchange bed (IX bed) during normal processing controlled and eradicated the growth of these organisms, thus functioning as designed. In each instance, within 12 to 24 hours, microbial readings were back to within specified limits.

Besides examining system effectiveness in controlling the various organisms, the contribution of various system components was examined with respect to microbial activity. Components studied in this regard included the sterilizer, VRA and ion exchange bed.

The sterilizer in the PDWP was designed to heat the waste water to 250 degrees F and maintain it at that temperature for 20 minutes minimum/40 minutes average residence time. These conditions, per John J. Perkins in Principles and Methods of Sterilization in Health Sciences, are expected to exceed the bacteria's thermal tolerance and,

therefore, kill them. During IPT/AT, it was found that microbial contamination existed downstream of the sterilizer within one day of system startup. Without further testing, it can not be determined if this was a failure of the sterilizer design or a result of startup difficulties which caused the sterilizer to cool down to approximately 100 degrees F and thus possibly allowed the microorganisms to pass through without being killed. Additionally, without further testing, it can not be determined if the elimination of the sterilizer prevents potable quality water from being produced. However, examining the performance of the PDWP, and knowing that significant numbers of microorganisms existed downstream of the sterilizer, one can make the preliminary conclusion that the sterilizer is not required in the system to produce specification quality water.

The VRA, though primarily designed to eliminate volatile organics, also contributed to the eradication of microbial activity. Water entered the VRA with an average microbial activity of approximately 59,500 CFU/100 ml; water exiting the VRA had an average microbial activity of 7060 CFU/100 ml over the course of IPT/AT. This data was tremendously skewed as a result of the sterile sampling port downstream of the VRA becoming contaminated. Prior to the contamination of this sample port, the water exiting the VRA was within the potable water quality specified limit of 1 CFU/100 ml. Additionally, other small scale VRA testing performed by Hamilton Standard shows similar results: a microbial challenge of $> 10^7$ CFU/ml was reduced to less than 1 CFU/100 ml within the VRA. Based on this data, the VRA is extremely efficient in controlling microbial activity.

The last system component examined for its ability to control microbial contamination was the ion exchange bed. Since the ion exchange bed was downstream of the VRA, the microbial concentration at the outlet of the VRA was defined as the inlet concentration to the ion exchange bed. Of 112 samples taken at the outlet of the ion exchange bed, 106 of them were within the specified limits of ≤ 1 CFU/100 ml. Of the remaining six samples, the average microbial activity was 3.67 CFU/100 ml with the worst case microbial concentration of 11 CFU/100 ml. This data indicated that the ion exchange bed reduced any remaining microbes by 99.98%.

CHEMICAL PERFORMANCE

Several parameters were monitored to determine the chemical performance of the PDWP including iodine concentration, pH, conductivity, organic carbon concentration and the concentration of various trace metals. The most significant of these results are discussed further in the paragraphs that follow.

Iodine Concentration:

NASA specified requirements for residual iodine call for a minimum of 1 ppm and a maximum of 4 ppm in the potable

water. Residual iodine is defined as elemental iodine, I₂, and does not include other forms such as iodides. The specified limit for all forms of iodine is <= 15 ppm. Throughout the system testing, total iodine concentration remained within the specified limits. However, the residual iodine concentration is the more important of the two measures, since elemental iodine is what kills and controls bacteria within the system. A total of 87 samples of product water were analyzed for residual iodine content and were found to have an average concentration of 3.42 ppm and a range from 0.7 ppm to 4.7 ppm. Though the residual iodine did exceed the 4 ppm limit on 25 of the 87 samples (approximately 30%), total iodine concentrations were never exceeded. Hamilton Standard was pleased with the performance of the ion exchange bed in this regard and recognizes that minor design modifications are required, so that this parameter will be within specification limits at all times.

Ph:

NASA's potable water quality specification calls for ph to be a minimum of 6.0 and a maximum of 8.5. Throughout system testing, the ph of the water was monitored through the different processing steps from inlet to outlet. The average ph of waste water entering the processor was 6.0 and ranged from 5.2 to 6.6. The ph of the water was pushed down to an average of 5.42 at the exit of the MF beds and then pushed even lower, to 4.15, at the exit of the VRA. This low reading at the VRA outlet was attributed to the chemical reactions taking place within it and is a direct result of the reaction by-products, which include acetic and propanoic acids. All of these constituents drive the ph of a solution down. By removing these compounds in the ion exchange bed, the ph should return to a neutral value. However, during DST and IPT/AT, the ph of the product water exiting the ion exchange bed averaged 4.94 and ranged from 4.6 to 6.4. Investigation of this performance outage identified the low ph to be a direct result of the concentration of iodine in the water. Because of the high purity of the processed water, even a small concentration of iodine in the water can significantly affect its ph. This result is consistent with results obtained from previous tests performed by Hamilton Standard and others. This data points out that the potable water quality specification is inconsistent and should be changed such that the minimum allowable product water ph equals 4.5. This recommendation has been forwarded to Boeing for further study and review.

Total Carbon/Total Organic Carbon:

Total carbon and total organic carbon are two parameters used to monitor the extent of contamination of the waste water. Waste water constituents contributing to these measures include the shower and laundry soaps, humidity condensate contaminants, oral hygiene water and many of the other waste water sources. The MF beds within the system were designed to remove the bulk of the organics

with the exception of the low molecular weight volatile substances, which were removed by the VRA. During system testing, water samples were drawn from every sample port and were analyzed for TOC. The waste water was found to have an average of 81.5 ppm TOC as compared with an inlet water model maximum of 360 ppm. The table below presents the average TOC values immediately downstream of each processing step.

PROCESSING STEP	AVERAGE TOC (PPM)	% TOTAL DECREASE
Filtration	51.9	36%
MF bed #1	23.4	71.3%
MF bed #2	12.1	85%
VRA	3.14	96%
IX Bed (Product Water)	0.49	99.3%

The first notable item is that the 0.5 micron filter decreased the measured TOC by 36%. It is surmised that skin cells found in the shower water were trapped by the filter, and thus the reduction in TOC was realized. Secondly, the MF beds performed as designed. The first MF bed removed a significant amount of the soaps with the second MF bed polishing the water further. The remaining TOC at the outlet of the second MF bed was attributed to the volatile compounds such as methanol and ethanol that are subsequently removed by the VRA. From the table, it can be seen that the VRA does burn up the volatiles by the TOC decrease exhibited. The measured TOC at the outlet of the VRA was characterized and found to contain both acetic and propanoic acids, by-products of the oxidation reaction of the alcohols in the VRA. Based on this data, Hamilton Standard determined that the VRA performed as designed.

Finally, the product water averaged 0.49 ppm TOC during steady state system operation. During test startup for DST and IPT/AT, initial TOC values were approximately 1 ppm. As the system continued to operate, the product water TOC decreased steadily until it was consistently within the specified limit, 0.50 ppm, and averaged 0.49 ppm during steady state operation. Hamilton Standard was pleased with the PDWP's ability to remove the organic constituents contaminating the waste water and as a result will be baselining two MF beds and the VRA for the flight system. However, further investigation of this startup performance phenomenon is required to gain a better understanding of the system startup dynamics.

Conductivity:

Conductivity was a parameter measured to indicate the extent of contamination in the water, though no comparison was made to the NASA water quality specification since no product water conductivity limit was identified. Various salts and trace metals are conductive, therefore, the higher the conductivity reading, the greater their concentration.

Contaminants of special interest include sodium, potassium, calcium, chlorine, and sulfate. During system testing, conductivity readings were monitored at every sample port. The table below summarizes the average conductivity values of the water after each of the processing steps.

PROCESSING STEP	CONDUCTIVITY (μ MHO/CM)	% TOTAL DECREASE
Waste Water	308	n/a
After Filtration	310	n/a
After Sterilization	313	n/a
After MF bed #1	3.85	98.8
After MF bed #2	1.97	99.4
After VRA	21	n/a
After IX Bed	2.86*	99.1
Product Water	3.01*	99

* Note that the residual iodine contributes to conductivity in the product water.

Examining the data in the table, the following conclusions can be drawn:

The conductivity does not decrease as a result of filtration and sterilization as would be expected, since these steps do not remove any conductive contaminants.

A 98% reduction in conductivity was achieved as a result of the chemical interaction between the salts and trace metals and the ion exchange resins in the MF bed. This result validates the design assumptions that the first MF bed will remove all contaminants until expended and that the second MF bed experiences little loading until the first MF bed experiences breakthrough.

After conductivity breakthrough of the first MF bed occurred, but prior to replacing the expended bed, the second MF bed functioned as intended by removing the various contaminants not removed in the first bed. A representative set of data is shown below. It was obtained over a 36 hour period from bed breakthrough during IPT/AT occurring on 7/29 through 7/30, when the bed was replaced.

BED #1 OUTLET	BED #2 OUTLET	% REDUCTION
7.5	2.2	n/a
88.7	2.2	97.55
130	2.8	97.8
170	1.4	99.2

The conductivity increases at the outlet of the VRA approximately 10 times over the water entering it. Once again, this phenomenon can be attributed to the reaction

occurring in the VRA and the by products that are formed as a result of this reaction.

The ion exchange bed successfully performed the final water polishing function. Conductivity of the fully processed water was approximately 3 μ MHO/cm. This is a 99% reduction in conductivity and indicates that those conductive substances present in the waste water were removed as a result of the processing.

As noted above, when conductivity breakthrough of the first bed occurred, the second MF bed removed the contaminants that broke through. During system testing, the different contaminants causing the conductivity breakthrough were monitored to verify design assumptions pertaining to bed life. During DST and IPT/AT, four MF bed breakthroughs occurred. Two important characteristics of these breakthroughs must be compared: total waste water throughput and the identification of contaminants breaking through. The table below identifies the quantity of waste water processed by each bed.

START DATE	BREAKTHROUGH	CHANGEOUT	TOTAL DAYS	POUNDS @ BREAKTHROUGH	TOTAL POUNDS
2/25	3/31	4/8	42	5400	7700
4/8	4/24	4/27	19	5100	5750
7/18	7/29	7/30	14	4750	-
7/30	8/15	8/16	17	6000	-

An average of 5300 pounds of waste water was processed prior to breakthrough occurring. Related back to space station flight requirements, this throughput is equivalent to 21 days of processing at an average of 250 lbs/day. Thus, it exceeded the 15 day minimum interval between bed changeouts.

Besides proving that bed longevity exceeded the flight requirement, it was also important to understand which of the contaminants broke through first so that the resin expended first was identified. In all four cases, sodium came through first quickly followed by potassium. Additionally, ammonium, phosphate and chloride broke through. Typical values of these contaminants at a conductivity ratio of 0.55 are listed in the table below.

COMPONENT	CONCENTRATION PRIOR TO BREAKTHROUGH	CONCENTRATION AT 0.55
Sodium	0.1 ppm	35 ppm
Potassium	0.1 ppm	4.3 ppm
Ammonium	0.1 ppm	1.6 ppm
Phosphate	0.1 ppm	1.4 ppm

Additionally, an increase in both total organic and total inorganic carbon was experienced while the turbidity of the water remained the same. These results validated the various design assumptions that were made pertaining to the MF beds.

The last aspect of bed performance examined relates to a question posed in a 1992 ICES paper. This question asked if MF bed performance is impacted by bed sterilization. For DST, the MF beds were not sterilized and their performance was equivalent to the performance of the IPT/AT MF beds which were sterilized using gamma radiation. Therefore, the answer to this question is that multifiltration bed performance does not appear to be impacted by sterilization or the lack thereof. However, if beds are stored for long periods before use, sterilization may be needed.

Throughout the course of DST and IPT/AT, the opportunity to evaluate breakthrough of the ion exchange bed never occurred. The only information available is that an average of 12,000 pounds of water flowed through the IX bed during both DST and IPT/AT with no breakthrough occurring, thus indicating that the IX bed life was longer than expected. In both instances, water meeting the water quality specifications was consistently produced.

OTHER RESULTS:

Filter Life -

The depth filter is an important component within the water processor. Its function was to remove particles within the size range of 100 to 0.5 microns. For this test, water entered the system prefiltered to 100 microns to simulate the various filters baselined for use on space station at the point of waste water generation. Two aspects of the depth filter performance were observed during DST and IPT/AT: filter life (waste water throughput versus differential pressure) and the effect of unsterilized, microbially active water on filter performance.

During system testing, five of seven filters installed met or surpassed the defined end of life, 15 psid, as shown in the table below.

FILTER	DELTA-P	THROUGHPUT	# DAYS INSTALLED
D1	15 psid	1750 lbs	13 days
D2	18 psid	5000 lbs	23 days
D3	27 psid	4750 lbs	20 days
D4*	4 psid	2000 lbs	7 days
I1	23 psid	5200 lbs	16 days
I2	16 psid	4400 lbs	11 days
I3*	3 psid	2700 lbs	7 days

*System testing was completed prior to expending these filters.

Since the depth filter is an expendable, it must have a sufficient life span to function for 15 days between changeouts. As noted in the table for D1 through D3, I1 and I2, the average number of days a filter was installed in the PDWP was in excess of 16 days. However, to compare this

to space station flight requirements, the data must be examined at a pressure differential of 15 psi for those filters that were expended.

FILTER	THROUGHPUT @ 15 PSID	LIFE @ 250 LB/DAY
D1	1750 lbs	7 days
D2	4700 lbs	18.8 days
D3	4200 lbs	16.8 days
I1	5000 lbs	20 days
I2	4200 lbs	16.8 days

Average including D1 3970 lbs

Average not including D1* 4525 lbs

*It is appropriate to exclude the performance of filter D1 since its life was shortened considerably due to the extremely heavy particulate loading induced as a result of washing the new towels and jumpsuits at the beginning of DST.

Based on processing 250 lb/day, the average filter life was 18 days, thus exceeding space station design requirements. It is important to note that the selection of 15 psid as the end of filter life appears to be low. In each of the instances where the filter was run to a higher pressure differential, no system operational problems were encountered.

The question of microbially active water shortening filter life was posed and can be answered only with respect to its effect on the filter meeting space station design requirements. Since the filter exceeds the 15 day life, it can be concluded that microbially active water does not degrade filter life. However, it is not known at this time if microbially inactive water with the same particulate loading would require the same, more or less throughput to develop the same delta-P.

A second question posed asked if prefiltering of the waste water was sufficient to keep the regenerative heat exchangers from fouling. During DST and IPT/AT, heat exchanger effectiveness was continuously monitored. During both of these tests, the regenerative heat exchanger efficiency was consistently at approximately 96% for the hot side and approximately 50% for the cold side. Since no reduction in heat exchanger efficiency was noted, any fouling (if it occurred) did not affect heat exchanger performance.

CONCLUSION

The Hamilton Standard test program run on the Predevelopment Water Processor proved that the concept of a combined water processor can successfully process waste hygiene and laundry water, humidity condensate and processed urine into potable quality water. The various system components designed to achieve this end

functioned well. The 0.5 micron depth filter selected for use met its life requirement and will be baselined for the flight water processor. The system sterilizer's benefit was not proven during system level testing. As a result, the sterilizer has not been baselined for use within the flight water processor. However, further verification testing must still be performed to conclude if this is the appropriate system schematic decision. The multifiltration beds, VRA and ion exchange bed all performed well. These components have been baselined for flight system use. Only final optimization is required for each of these. This can be achieved through small scale and/or system level testing.

During DST and IPT/AT, Hamilton Standard decided to focus only on those system components that directly contributed to the removal of contaminants from the water. Developmental testing and significant design finalization is still required for some of the mechanical components such as the rotary water/air separator, the system process pump, system valving and sensors.

The information presented above does indicate the need for more design and development work. However, Hamilton Standard has proven that potable quality water can be recovered from the various real sources contributing to the waste stream. In March, 1992, processed water obtained from the system and confirmed to meet the water quality specification was taste tested by approximately 20 volunteers. All agreed that if they were living and working on an earth orbiting platform, none would have reservations drinking this water.

References

1. Principles and Methods of Sterilization in Health Sciences, 2nd edition; John J. Perkins; Charles C. Thomas, publisher, Springfield, Illinois; 1983.
2. Space Station Water Processor: Current Flight Design; Albert M. Boehm, Arthur K. Colling, Jr., Michael J. Heldmann, John W. Steele, R. Glenn Shaw; SAE Technical Paper Series; SAE, 400 Commonwealth Drive, Warrendale, Pennsylvania; 1992.