

NATIONAL ADVISORY COMMITTEE FOR AERONAUTICS

TECHNICAL MEMORANDUM NO. 1140

PRESSURE RECOVERY FOR MISSILES WITH REACTION
PROPULSION AT HIGH SUPERSONIC SPEEDS
(THE EFFICIENCY OF SHOCK DIFFUSERS)*

By Kl. Oswatitsch

Abstract: The problem of the intake of air is treated for a missile flying at supersonic speeds, and of changing the kinetic energy of the air into pressure with the least possible losses. Then calculations are carried out concerning the results which can be attained. After a discussion of several preliminary experiments, the practical solution of the problem at hand is indicated by model experiments. The results proved very satisfactory in view of the results which had been attained previously and the values which were anticipated theoretically.

Outline:

1. Introduction	3
2. Theoretical Considerations	3
3. Results of the Preliminary Experiments	21
4. Model and Experimental Method	23
5. Experimental Results	27
6. Discussion of Some Additional Experiments. Possibilities of Further Increase of Performance	39
7. Summary	41
8. Bibliography	42

Notations

- F_e entrance cross section
- F_D minimum section of diffuser (narrowest cross section behind the combustion chamber)

*"Der Druckrückgewinn bei Geschossen mit Rückstossantrieb bei hohen Überschallgeschwindigkeiten (Der Wirkungsgrad von Stossdiffusoren)," Forschungen und Entwicklungen des Heereswaffenamtes, Bericht Nr. 1005, Göttingen, January 1944.

F_o	cross section of stream tube that goes into inlet in zone of undisturbed flow
F^{*1}	"critical" cross section behind a normal shock
h	throat opening (See fig. 6.)
Ma_o	Mach number ahead of free stream (w_o/c_o)
p_{st}	static pressure
p_p	pitot pressure
p_o^o	total pressure or pressure of tank for undisturbed flow equivalent to pressure of zero velocity for isentropic transformation
γ	angle of shock with direction of flow
ρ^*, W^*	are density and velocity in throat (= "critical" density and "critical" velocity for corresponding values in combustion chamber)
W	velocity
c	velocity of sound
ρ	density
T	absolute temperature
K	ratio of specific heats
G	amount of through flow
G_{Ab}	amount due to suction

$$x_1 = 1 + \frac{k-1}{2} Ma_1^2$$

$$y_1 = 1 + \frac{k-1}{2} Ma_1^2 \sin^2 \gamma_1$$

The values with no index are always for the combustion chamber. The subscript o indicates the initial region of flow; subscripts 1 and 2, etc. indicate the values after the first, second, etc. shock.

The static pressure in the initial region of flow, behind the first shock, etc., are not designated by P_{st_0} , P_{st_1} , but simply by p_0 , p_1 , etc. The upper index 0 indicates the corresponding "total values" p_1^0 , p_2^0 , and hence, the total pressure behind the first, second shock. T^0 , c^0 are the total temperature and the speed of sound for the air brought to rest. These two values are the same everywhere in the region of initial flow, behind the first and second shocks and in the combustion chamber. The lower index can therefore always be dropped in this case.

I. INTRODUCTION

If we wish to design missiles with rocket propulsion, it is a question of not carrying the oxygen which is necessary for combustion along in the missiles, but of taking it from the air during flight. In this regard we must strive to get air of maximum possible pressure for use within the missile. As we shall see in the following, however, the recovery of pressure with minimum loss for bodies flying at high supersonic speeds offers considerable difficulties. We received the task of treating this problem of pressure recovery for missiles with reaction propulsion from the OKH Wa F. After great initial difficulties the investigations led to success.

Two short works on various preliminary experiments were reported to the writer. In the following, the important results of these first reports are briefly recalled and then the new, conclusive results are made known.

2. THEORETICAL CONSIDERATIONS

If we hold a simple static tube (pitot tube) in a supersonic flow, it does not show the so-called total pressure of the initial region of flow p_0^0 which we get by isentropic compression when the air flow is reduced to a velocity $w = 0$; we get a smaller pressure, the pitot pressure p_p . In contrast to subsonic flow

where $p_p/p_o^\circ = 1$, this value is always less than one at supersonic speeds. The physical basis of this phenomenon is due to the fact that a wave is set up ahead of the pitot tube, and in this wave the changes of condition are no longer isentropic, and considerable increases in entropy occur. We can also say that in the wave at the pitot tube a drop in the total pressure from the value p_o° to p_p takes place and p_p is nothing but the total pressure behind the middle normal part of the head wave. The value of the pitot pressure can be calculated precisely. A normal shock is set in front of the pitot tube and behind it the air is compressed isentropically. For low supersonic speeds the greatest part of the pressure rise takes place behind the shock, but for high supersonic speeds it takes place in the shock itself. In figure 1 (solid and dotted curves for $n = 1$) we have the ratio of pitot pressure to total pressure in the initial region of flow and the ratio of pressure just behind the normal shock to the total pressure in the initial region of flow for $k = 1.400$. In the following, we shall first be interested in the ratios at high supersonic speeds.

The immediate investigation - to recover the pressure at the head of a flying missile - is that of introducing a reversed Laval nozzle into it and, with a steady rise in pressure in it, of translating the supersonic flow into a subsonic flow of small velocity. This method fails, however, since it happens that generally a normal compressibility shock is set up at the entrance to the Laval nozzle just as in the case of a pitot tube and this leads to a relatively sharp increase in entropy and to a loss in pressure recovery similar to that for the pitot tube itself. We can now think of the channel leading through the missile as expanded, and it is clear that the shock will move into the missile if the diameter of the Laval nozzle is above a certain value and as the opening of the Laval nozzle increases, the shock finally becomes more conical in form. With a sufficiently wide opening, supersonic velocity will prevail throughout the channel which leads through the missile. The limits for which this occurs may be very precisely stated, as has been proved by numerous experiments. The shock can no longer be maintained ahead of the missile if more air is sucked away than enters the channel through the shock, that is, if the narrowest

part of the Laval nozzle is wider than the smallest permissible cross section of a Laval nozzle appropriate to the total pressure behind the shock (1). If we calculate the corresponding narrowest cross section, we find that for high Mach numbers too only relatively small contractions of the Laval nozzle are permissible if we wish to avoid the presence of a normal shock ahead of the nose of the missile. (See fig. 2.)

It has not yet been determined whether this undesired flow phenomenon always occurs with rather sharp contractions of the Laval nozzles or if it depends on the earlier history of the flow. It is entirely certain that the flow maintains this phenomenon once it has started.

If we are satisfied with the pressure recovery of the normal shock, then no convergent-divergent Laval nozzle is to be built in the head of the missile, but rather a subsonic diffuser with sharp leading edges, and hence a divergent channel.

For all our investigations it is not only a matter of attaining the maximum possible pressure recovery but also, at the same time, of keeping the drag of the missile as small as possible. Normal shocks which lie ahead of the missile are therefore to be avoided in all cases. In every case, therefore, the amount of air which flows through will be regulated so that the shock occurs in the subsonic diffuser rather than ahead of it. This has only a secondary effect on the recovered pressure, but it can lower the drag of the missile remarkably. (This has already been shown by Dr. Ludwig, AVA, in an unpublished work.)

According to the present state of our knowledge and on the basis of our experimental methods, we must establish the rule that the channel behind the entrance into the missile is to be contracted at most so that it corresponds to the ratio F^*/F_0 (fig. 2) for the Mach number at the missile entrance.

Instead of scooping the air directly from the undisturbed flow, we can now permit compression on a conical tip of the missile and then have access to the interior of the missile by means of a circular slot.

That this must lead to a better pressure recovery is readily apparent from the following considerations. An isentropic compression of air at supersonic speed can be thought of as a compression by means of a large number of oblique shocks with small increases of pressure, which slow up the air to low supersonic speeds, a normal shock which leads to high subsonic velocities and finally isentropic compression in an ideally functioning subsonic diffuser. The pressure recovered by this arrangement must be equal to the pressure p_c^0 . The smaller the number of oblique compression shocks, the worse will be the pressure recovery; but it does happen that introducing one or two oblique compression shocks ahead of the normal shock can achieve very considerable increases of the pressure within the missile.

Let us consider a supersonic flow which is transformed into a subsonic flow by $n-1$ oblique and one normal shock, hence, by n shocks in all. Between the individual shocks we assume that the condition of the air does not change. It neither expands nor contracts. We can now ask how the individual shocks must be set up in order to obtain a maximum value of pressure recovery. It is clear that we shall not arrive at the same result if we take a number of weak oblique shocks and one strong normal shock as if we take several strong oblique shocks and then a single very weak normal one. In order to solve this problem we must now determine what we mean by optimum pressure recovery. There are two main possibilities. Corresponding to them, we shall solve two problems in the following:

(1) How must I set up $n-1$ oblique and one normal compression shock for a given Mach number of the flow in order that the total pressure behind the last shock is a maximum.

(2) How must I set up n compression shocks behind one another for a given Mach number of the flow in order that the pressure behind the last shock is a maximum.

We can treat the first task as the problem of the optimum pressure recovery assuming an ideally functioning subsonic diffuser behind the last compression shock. The second task is the problem of the optimum pressure recovery if I assume a very inefficient subsonic diffuser behind the last compression shock.

The curves in figure 1 give the results of the solutions of these two problems for $n = 1, 2, 3,$ and 4 compression shocks; the solid curves hold for the first problem and the dotted curves for the second. As has already been mentioned the curves for $n = 1$ are none other than the curves for the pitot pressure (solid) and for the pressure behind a normal compression shock (dotted) in a supersonic flow. In this case it is no longer a question of a maximum problem.

In the following we shall repeat the calculations for determining the curves. However, they have no significance for the comprehension of our later derivations.

We indicate the values in the initial region of flow by means of the subscript 0, and the values behind the first, second, and n th compression shock by means of the indices 1, 2 . . . n , p_i is the static pressure behind the i th shock although we usually indicate the static pressure by p_{st} , we shall simply write p_0 instead of p_{st0} and p_1 instead of p_{st1} , etc. in order to avoid the difficulty of writing double subscripts; Ma is the Mach number; p_0 is the total pressure and $p_0^0, p_1^0, p_2^0,$ etc., are the total pressures in the initial region of flow and behind the first, second, etc. shock; γ is the angle the shock makes with the direction of flow before the shock.

The total-pressure ratio or the throat factor, as this ratio is often called, of the $(i + 1)$ th shock is then given by the following equation:

$$\frac{p_{i+1}^0}{p_i^0} = \left(\frac{k-1}{k+1} + \frac{2}{k+1} \frac{1}{Ma_i^2 \sin^2 \gamma_i} \right)^{-\frac{1}{k-1}} \left(\frac{2k}{k+1} Ma_i^2 \sin^2 \gamma_i \right)^{-\frac{1}{k-1}} \left(\frac{k-1}{k+1} \right)^{-\frac{1}{k-1}} \quad i = 0, 1 \dots n-1 \quad (1)$$

where k is the ratio of the specific heat. (See (2).)

The change of the total-pressure ratios therefore depends only on the product $Ma_i \sin \gamma_i$. But along with the total pressure the Mach number also changes at each shock. We shall use the following simple formula for the Mach number, which as far as we know, is not yet generally known in this form:

$$1 + \frac{k-1}{2} Ma_{i+1}^2 = \frac{1}{1 + \frac{k-1}{2} Ma_i^2 \left(\frac{2k}{k+1} Ma_i^2 \sin^2 \gamma_i + \frac{k-1}{k+1} \right) \left(\frac{k-1}{k+1} + \frac{2}{k+1} \frac{1}{Ma_i^2 \sin^2 \gamma_i} \right)} \quad (2)$$

$i = 0, 1, \dots, n-1$

The problem is now reduced to the following: We must choose the angles $\gamma_i (i = 0, 1, \dots, n-1)$ and the Mach numbers $Ma_i (i = 1, 2, \dots, n-1)$ for a given Ma_0 so that

$$\frac{p_n^0}{p_0^0} = \frac{p_n^0}{p_{n-1}^0} \frac{p_{n-1}^0}{p_{n-2}^0} \dots \frac{p_2^0}{p_1^0} \frac{p_1^0}{p_0^0} \quad (3)$$

is a maximum.

For the sake of simplicity we introduce the following expressions as new unknowns instead of the values γ_i and Ma_i .

$$\frac{k-1}{2} Ma_i^2 + 1 = x_i; \quad \frac{k-1}{2} Ma_i^2 \sin^2 \gamma_i + 1 = y_i \quad (4)$$

and set

$$\frac{1}{\frac{k-1}{k+1} + \frac{2}{k+1} \frac{1}{Ma_i^2 \sin^2 \gamma_i}} = \frac{k+1}{k-1} \frac{y_i - 1}{y_i} = f(y_i) = f_i$$

$$\frac{1}{\frac{2k}{k+1} Ma_i^2 \sin^2 \gamma_i - \frac{k-1}{k+1}} = \frac{k-1}{k+1} \frac{1}{\frac{1/k}{(k+1)^2} y_i - 1} = g(y_i) = g_i$$

We can then express equations (2) and (3) very simply by the functions f_i and g_i . Since the last compression shock is to be a normal shock, $\sin \gamma_{n-1} = 1$ and, hence,

$$x_{n-1} = y_{n-1}$$

Since $(k-1) \ln p_n^0/p_0^0$ must have a maximum at the same point as p_n^0/p_0^0 , we can now formulate our problem thus

$$\begin{aligned} (k-1) \ln \frac{p_n^0}{p_0^0} &= (k-1) \sum_{i=0}^{n-1} \ln \frac{p_{i+1}^0}{p_i^0} \\ &= \sum_{i=0}^{n-1} (k \ln f_i + \ln g_i) \end{aligned}$$

is to have a maximum under the conditions that

$$x_{n-1} = y_{n-1}$$

and

$$x_{i+1} = x_i f_i g_i$$

for

$$i = 0, 1 \dots n-2$$

Hence, we have $2n-1$ variables, namely $x_1, x_2 \dots x_{n-1}$ and $y_0, y_1 \dots y_{n-1}$ and n auxiliary conditions.

To solve the problem we now introduce, using methods which are well known, as many new variables $\lambda_i (i=1 \dots n)$ as there are auxiliary conditions and we postulate that the function

$$\sum_{i=0}^{n-1} (k \ln f_i + \ln g_i) + \sum_{i=0}^{n-2} \lambda_{i+1} (x_{i+1} - x_i f_i g_i) + \lambda_n (y_{n-1} - x_{n-1})$$

of the $3n-1$ variables x_1 to x_{n-1} , y_0 to y_{n-1} , λ_1 to λ_n shall have a maximum. That is, we must set the partial derivatives of the function with respect to all the variables equal to zero. This gives as many equations as unknowns, so that we can determine their values. The derivatives with respect to x give:

$$\lambda_i - \lambda_{i+1} f_i g_i = 0; \quad i = 0, 1 \dots n-2 \quad (6)$$

and

$$\lambda_{n-1} - \lambda_n = 0 \quad (7)$$

If we designate the derivatives of the functions with respect to their argument by f_i' and g_i' , the differentiations with respect to y give:

$$k \frac{f_i'}{f_i} + \frac{g_i'}{g_i} - \lambda_{i+1} x_i (f_i' g_i + g_i' f_i) = 0 \text{ for } i = 0 \dots n-2 \quad (8)$$

and

$$k \frac{f_{n-1}'}{f_{n-1}} + \frac{g_{n-1}'}{g_{n-1}} + \lambda_n = 0 \quad (9)$$

The derivatives with respect to λ again give the auxiliary conditions

$$x_{i+1} = x_i f_i g_i \quad \text{for } i = 0 \dots n-2 \quad (10)$$

and

$$x_{n-1} = y_{n-1} \quad (11)$$

We can now easily express all λ and x by y and x_0 and with the aid of equations (6) and (7) we get

$$\begin{aligned} \lambda_{i+1} &= \lambda_{i+2} f_{i+1} g_{i+1} = \lambda_{i+3} f_{i+1} g_{i+1} f_{i+2} g_{i+2} \\ &= \lambda_n f_{i+1} g_{i+1} \dots f_{n-2} g_{n-2} \end{aligned}$$

and with the aid of (10) and (11)

$$x_i = \frac{x_{i+1}}{f_i g_i} = \frac{x_{i+2}}{f_i g_i f_{i+1} g_{i+1}} = \frac{y_{n-1}}{f_i g_i f_{i+1} g_{i+1} \dots f_{n-2} g_{n-2}}$$

and

$$x_i \lambda_{i+1} = \frac{y_{n-1} \lambda_n}{f_i \xi_i}$$

Substituting this in equation (8) gives

$$k \frac{f_i'}{f_i} + \frac{\xi_i'}{\xi_i} - y_{n-1} \lambda_n \left(\frac{f_i'}{f_i} + \frac{\xi_i'}{\xi_i} \right) = 0 \quad i = 0, 1, \dots, n-2 \quad (12)$$

But that is none other than the fact that

$$y_0 = y_1 = y_2 = \dots = y_{n-2}$$

since all these values must satisfy the same equation (12). We therefore have only two unknown y , namely y_0 and y_{n-1} . For these we readily get the formulas

$$y_{n-1} = x_0 (f_0 \xi_0)^{n-1} \quad (13)$$

and, substituting (9) in (11)

$$k \frac{f_0'}{f_0} + \frac{\xi_0'}{\xi_0} + y_{n-1} \left(k \frac{f_{n-1}'}{f_{n-1}} + \frac{\xi_{n-1}'}{\xi_{n-1}} \right) \left(\frac{f_0'}{f_0} + \frac{\xi_0'}{\xi_0} \right) = 0 \quad (14)$$

Hence, for a given x_0 , that is, for a given Mach number of the initial flow, we have two equations for the unknowns y_0 and y_{n-1} and the problem has therefore really been solved. If we carry out the differentiations of the functions f and g (5) and substitute x_0 and $y_{n-1} = x_{n-1}$ from equation (14), we get the following in place of equations (13) and (14).

$$\frac{1 + \frac{k-1}{2} Ma_0^2}{1 + \frac{k-1}{2} Ma_{n-1}^2} = \left[\frac{\frac{4k}{(k+1)^2} (y_0 - 1)}{y_0 - 1} y_0 \right]^{n-1} \quad (15)$$

$$y_0 = \frac{1}{2} \left(1 + h + \sqrt{1 - \frac{k^2 + 1}{k} h + h^2} \right)$$

where

$$h = \frac{(k-1) Ma_{n-1}^4 + \frac{5-k}{2} Ma_{n-1}^2 - 1}{\frac{3k+1}{2k} Ma_{n-1}^2 - 1} \quad (16)$$

In carrying out the calculation it is practical to start with Ma_{n-1} rather than with Ma_0 and then with the aid of equation (16) to determine y_0 and then using equation (15) the appropriate Ma_0 .

From the equality of all y_i for $i=0$ to $n-2$ and because of equation (5) it follows that:

$$Ma_0 \sin \gamma_0 = Ma_1 \sin \gamma_1 = \dots = Ma_{n-2} \sin \gamma_{n-2} \quad (17)$$

It follows further that the total-pressure ratios (equation(1)) as well as the pressure ratios themselves for all oblique compression shocks are equal. From (16) it follows, moreover, that $Ma_{n-1} \neq Ma_0 \sin \gamma_0$, but

that Ma_{n-1} has a very definite relationship with $Ma_0 \sin \gamma_0$ and this relationship is independent of the number of compression shocks n and is also independent of the Mach number of the initial flow Ma_0 ; it depends solely on $Ma_0 \sin \gamma_0$ itself. The number of compression shocks first comes into consideration when we wish to determine Ma_0 from y_0 and Ma_{n-1} . The coordination of the values of Ma_0 , y_0 , $Ma_0 \sin \gamma_0$, and Ma_{n-1} is given in table 1 for $k = 1.400$.

TABLE 1.- MAXIMUM POSSIBLE TOTAL PRESSURES AFTER n
COMPRESSION SHOCKS

Ma_0	$n = 1$		$n = 2$			
	p_n^0/p_0^0	γ_0	$Ma_0 \sin \gamma_0$	Ma_{n-1}	p_n^0/p_0^0	
1.0	1.000	1.200	1.000	1.000	1.000	
1.5	.929	1.295	1.215	1.168	.980	
2.0	.721	1.432	1.470	1.388	.900	
2.5	.499	1.594	1.724	1.622	.751	
3.0	.328	1.773	1.966	1.854	.586	
3.5	.213	1.966	2.198	2.079	.435	
4.0	.139	2.169	2.418	2.288	.314	

Ma_0	$n = 3$				$n = 4$			
	γ_0	$Ma_0 \sin \gamma_0$	Ma_{n-1}	p_n^0/p_0^0	γ_0	$Ma_0 \sin \gamma_0$	Ma_{n-1}	p_n^0/p_0^0
1.0	1.200	1.000	1.000	1.000	1.200	1.000	1.000	1.000
1.5	1.253	1.125	1.075	.990	1.233	1.080	1.066	.996
2.0	1.227	1.279	1.222	.919	1.286	1.196	1.108	.968
2.5	1.116	1.443	1.365	.863	1.314	1.311	1.250	.913
3.0	1.612	1.600	1.508	.774	1.405	1.424	1.350	.833
3.5	1.614	1.752	1.649	.615	1.473	1.538	1.450	.728
4.0	1.716	1.892	1.782	.488	1.537	1.639	1.545	.626

The third place after the decimal point is not necessarily valid.

From the values given above we can easily get all the other Mach numbers with the aid of equation (2).

In conclusion it is to be noted that the first problem loses its meaning if we drop the assumption that the last compression shock is a normal shock.

In this case it is clear that the minimum loss of total pressure or the minimum increase in entropy is reached when all n compression shocks degenerate into "Mach lines" with vanishing increase in pressure, and thus there is no loss of total pressure but also there is no increase in pressure.

We shall dispense with the proof that the solution of our problem actually represents the maximum and not another extreme value or a saddle configuration.

The solution of problem 2 is now relatively short. The ratio of the static pressures before and after a compression shock is given by the following equation:

$$\frac{p_{i+1}}{p_i} = \frac{2k}{k+1} Ma_i^2 \sin^2 \gamma_i - \frac{k-1}{k+1} = \frac{1}{g(\gamma_i)} = \frac{1}{g_i} \quad (18)$$

We see that the pressure ratio for a compression shock for a given Mach number of the initial flow is a maximum if $\sin \gamma_i = 1$, and, hence it is a case of a normal shock. Now if we did have solutions with n oblique shock waves, then we see that we can always arrive at a better pressure ratio if we replace the last oblique compression shock by a normal shock. That is the following holds for the maximum just as it did before:

$$y_{n-1} = x_{n-1}$$

The remaining auxiliary conditions are again the same as before. The problem differs only in the fact that a different function is to be made a maximum, namely

$$\ln \frac{p_n}{p_0} = \sum_{i=0}^{n-1} \ln \frac{p_{i+1}}{p_i} = - \sum_{i=0}^{n-1} \ln g_i$$

We again introduce the parameters λ_i to λ_n and by setting the derivatives with respect to x, y and λ

equal to zero we again get the necessary equations for our unknowns. The derivatives with respect to λ and x again give the same equations (6), (7), (10), and (11) since the auxiliary conditions have not changed and $\ln p_n/p_0$ does not depend on x . The derivatives with respect to y give:

$$\frac{\xi_i'}{\xi_i} + \lambda_{i+1} x_i (f_i' \xi_i + \xi_i' f_i) = 0; \quad i = 0, 1 \dots n-2 \quad (19)$$

and

$$-\frac{\xi_{n-1}'}{\xi_{n-1}} + \lambda_n = 0 \quad (20)$$

We again form the product $x_i \lambda_{i+1}$ and substitute it in (19). This gives

$$\frac{\xi_i'}{\xi_i} + y_{n-1} \lambda_n \left(\frac{f_i'}{f_i} + \frac{\xi_i'}{\xi_i} \right) = 0 \quad i = 0, 1 \dots n-2 \quad (21)$$

From which it again follows that

$$y_0 = y_1 = \dots = y_{n-2}$$

Hence equation (17) also is valid again.

From the auxiliary conditions we again get

$$y_{n-1} = x_0 (f_0 g_0)^{n-1} \quad (13)$$

and as a second equation for the unknowns y_{n-1} and y_0 we get the following by substituting λ_n from equation (20) in equation (21).

$$\frac{g_0'}{g_0} + y_{n-1} \frac{g_{n-1}'}{g_{n-1}} \left(\frac{f_0'}{f_0} + \frac{g_0'}{g_0} \right) = 0 \quad (22)$$

and so we have again arrived at our system of equations. If we again substitute the functions f and g and their derivatives and go back as far as possible to the original variables, we get

$$1 + \frac{k-1}{2} Ma_0^2 = \left(1 + \frac{k-1}{2} Ma_{n-1}^2 \right) \left(\frac{y_0^2}{1 + \frac{k-1}{2} Ma_{n-1}^2} \right)^{n-1} \quad (23)$$

and

$$1 + \frac{k-1}{2} Ma_{n-1}^2 = \frac{y_0(y_0 - 1)}{\frac{1+k}{(k+1)^2} y_0 - 1} \quad (24)$$

It is best to give y_0 first, calculate Ma_{n-1} from (24) and finally Ma_0 from (25).

In any case there is something we must consider in our calculation. In our mathematical approach it is not impossible that "expansion shocks" may also occur, which are of course physically meaningless since they contradict the second law of thermodynamics. Hence, in all our calculations, we must require that Ma_{i+1} be smaller than Ma_i or

$$x_{i+1} < x_i \quad (25)$$

Because of equation (10), which is valid for both problems, and $y_0 = y_1 = \dots = y_{n-1}$, this has the following as a consequence:

$$f_0 g_0 < 1$$

If we figure it out we get

$$y_0 > \frac{k+1}{2}$$

or

$$\frac{k+1}{2k} > y_0$$

Of these two conditions only the first has meaning as calculation readily shows. It states that the angle of the shock must always be greater than the Mach angle, which is nothing new. A consequence of this condition is the fact that we do not get a physically meaningful solution for the second problem between $Ma_0 = 1$ and about $Ma_0 = 1.5$. However, we can consider that in this range the solution for $n = 2, 3, 4$, etc., must coincide with the solution for $n = 1$.

In the second problem too, the connection between Ma_{n-1} and y_0 is independent of the number of compression shocks n and the Mach number of the initial flow Ma_0 . The results are given in the following table. We have given p_0/p_0^0 and p_n/p_0^0 rather than p_n/p_0 for $k = 1.400$. The last pressure ratio is shown in figure 1 since this alone offers a comparison with the solutions of problem 1.

TABLE 2.- HIGHEST ATTAINABLE PRESSURE AFTER n
COMPRESSION SHOCKS

Ma ₀	n = 1		n = 2			
	γ_0/P_0°	P_n/P_0°	γ_0	Ma ₀ sin γ_0	Ma _{n-1}	P_n/P_0°
1.0	0.528	0.528	1.200	1.000	1.000	0.528
1.5	.2727	.670	1.204	1.010	1.483	.670
2.0	.128	.576	1.342	1.308	1.591	.650
2.5	.0585	.416	1.500	1.581	1.784	.573
3.0	.0272	.279	1.675	1.837	1.998	.460
3.5	.0132	.136	1.859	2.071	2.211	.347
4.0	.0066	.122	2.048	2.289	2.412	.260

Ma ₀	n = 3				n = 4			
	γ_0	Ma ₀ sin γ_0	Ma _{n-1}	P_n/P_0°	γ_0	Ma ₀ sin γ_0	Ma _{n-1}	P_n/P_0°
1.0	1.200	1.000	1.000	0.528	1.200	1.000	1.000	0.528
1.5	1.201	1.002	1.483	.670	1.201	1.002	1.483	.670
2.0	1.274	1.170	1.520	.666	1.249	1.115	1.503	.668
2.5	1.360	1.342	1.611	.624	1.305	1.226	1.550	.643
3.0	1.455	1.500	1.729	.555	1.366	1.353	1.620	.594
3.5	1.554	1.665	1.851	.471	1.430	1.466	1.697	.542
4.0	1.655	1.810	1.975	.395	1.495	1.573	1.778	.495

If we do succeed in setting up the compression shocks in the manner given in table 1, then the values which are shown by the solid curves (fig. 1) are still not completely attainable since the subsonic diffuser behind the last normal shock implies still other losses. We can count on 10 percent of the total pressure being lost there so that 90 percent of the indicated values are attainable.

Conversely we can generally attain much higher values than those given by the dotted curves since the pressure recovery in the subsonic diffuser has not yet been figured in.

While the subsonic diffuser plays a very minor role at high Mach numbers and with only one compression shock, its effectiveness will increase as the number of shocks increase. This can be seen from figure 1. For if I finally have a large number of compression shocks, then the last one leads to very high subsonic speeds, and here I could practically double the pressure by means of an ideal subsonic diffuser. Hence, while the subsonic diffuser is of rather subordinate significance for scooping up the air at high Mach numbers with the aid of a single normal compression shock, this is no longer true in the presence of several compression shocks. Here the proper design of the subsonic diffuser is very important.

Our calculations show that we can attain very considerable improvements by adding one or two oblique compression shocks ahead of the normal shock. The idea of accomplishing this by scooping up the air in a circular slot at the nose of an ordinary missile was pursued several weeks before I began my experiments and without my knowledge by Dr. Ludwig, AVA. The experiments were interrupted in the early stages, however, due to the loss of interest of the authorities.

The possible arrangements are sketched in figure 3. (a) shows the arrangement with one oblique and one normal shock. For two oblique shocks two arrangements are possible in the main (b) and (c). It is a question how completely these can be realized. In the case of (b), as we shall see, the second oblique shock cannot be set up directly by a notch in the shell. Moreover, this arrangement may give greater drag than (c). For (c), on the other hand, it must still be made clear whether we can permit the prescribed oblique shock to enter the interior of the missile from the edge of the scoop without having the channel contract beyond the limit given in figure 2.

In our experiments it was not so very important to find suitable means of assuring a maximum possible pressure recovery. Primarily we wished to get a pressure recovery which was essentially higher than that of the normal shock, and in addition the function of the device was to be always reproducible without exception. We shall call this a shock diffuser since it makes the pressure recovery take place in several shocks rather than continuously.

3. RESULTS OF THE PRELIMINARY EXPERIMENTS

Since our Institute has only a rather small tunnel available (jet cross section 6×8 cm) only experiments with small models could be carried out. The first model has a caliber of 2 centimeters. The arrangement at the head of the missile was something like that of fig. 3(a), though the opening was rather large compared with the caliber. It amounted to 45 percent of the cross section of the missile. The static pressure was measured several millimeters behind the opening. The results were consistently bad and the measured pressure was always far less than the pitot pressure. The reasons for this failure are still not entirely clear. For this reason the investigations had to be repeated using all our previously gained experience. In any case we could already determine from our first experiments that the results for such small models depend to a large extent on the size of the model and hence on Reynolds number. This is not remarkable since in a supersonic injection tunnel of the type we used a transition of the laminar into the turbulent boundary layer is to be expected after about 2 to 3 centimeters. But such lengths occur especially in the missile noses we used.

In order to study the phenomena in the simplest cases we gave up the idea of having the air flow through the missile. Two ordinary circular cylinders of 1- and 2-centimeter diameter were manufactured, which had a pressure orifice in the forward surface. The forward surface also had a projecting rim. Tips of various shapes with a base area less than the area of the cylinder could be screwed on in front of the cylinder. (See fig. 5(a).) With the tip screwed off, we got the pitot pressure, as was to be expected. With the tip screwed on the pressure was somewhat lower as a rule, but in certain cases it exceeded it considerably. But these experiments proved to be nonreproducible in general. Schlieren observations showed that the flow phenomena were very unsteady. We shall return to these phenomena in the discussion of our final results.

There are three possible causes for the difference between the experiments and the results which were expected theoretically. First boundary-layer phenomena in supersonic flows can completely alter the flow picture

by pressure increase. Second, unstationary, periodically varying, flow conditions can appear. Third, the fact that the free jet extends a finite distance is important for large models. As we shall see, this can completely alter the results for supersonic flows.

Later the possibility arose of carrying out the experiments in a larger supersonic wind tunnel (cross section 13×15 cm) which has an arrangement for drying the air. Also we had the use of a model which had been constructed by Dr. Ludwig for his experiments, and we did use it after some changes were made. (See fig. 4.) A suction line was built in, A-L. The disturbing boundary-layer effects were supposed to be avoided by suction through a suction slot A. The entrance cross section F_e amounted to only a fraction of the cross section of the missile. The static pressure and the pitot pressure somewhat behind the entrance were measured. The mass flow could be varied by adjustment of the throat D. The tip of the missile could be screwed off in order to permit a slight change in the shape of the tip and the position of the suction slot.

In figure 5 the results are shown for the tip which performed best. The throat opening F_D , which was made dimensionless by the entrance opening F_e , was chosen as the abscissa. The pitot pressure and static pressure, which are made dimensionless by the total pressure of the free stream p_0^0 , are shown with suction on and off. The Mach number of the free stream was $Ma_0 = 2.9$. The Mach number at the point of measurement can be determined from the pitot pressure and the static pressure. If the ratio p_{st}/p_p is greater than 0.528 (p_{st} static pressure, p_p pitot pressure) we have subsonic flow, but if p_{st}/p_p is less than 0.528, then supersonic flow prevails. In order actually to recover the pressure, in the first case a slightly divergent channel (subsonic diffuser) had to be attached behind the point of measurement, and in the second case there came into consideration a supersonic diffuser which was actually a somewhat convergent-divergent or a rather long parallel channel with a subsonic diffuser attached. In either case the combustion chamber was then attached onto the subsonic diffuser, and from it the air flowed through a Laval nozzle whose

narrowest point would serve for our throat. How the flow would act if we had a still greater contraction behind the entrance cross section F_e is hard to predict. But we could predict it with certainty if $p_{st}/p_o = 0.528$. For in this case we know that about 90 percent of the total pressure at the beginning of a subsonic diffuser is recovered by the diffuser. Since, in our experiments p_p/p_o^o was about 0.60 for $p_{st}/p_o = 0.528$, it could be predicted that in the combustion chamber a static pressure of $0.90 \times 0.60p_o^o = 0.54p_o^o$ must be obtainable.

The experiments discussed above also showed that the suction offered no practical change in the pitot pressure. Only in the static pressure did occasional considerable changes occur, the procurement of which was not to be expected with the construction of a proper shock diffuser with a subsonic diffuser.

On the basis of the results of the preliminary experiments and of the new knowledge in the field of subsonic diffusers (3) a model was built concerning which a detailed report will be given in the following.

4. MODEL AND EXPERIMENTAL METHODS

The model (fig. 6) shows in general the same arrangement which has already been used in the preliminary experiments (fig. 4). An important difference lies in the fact that a subsonic diffuser U-D now is attached directly on to the entrance and then the combustion chamber E-K of about the same length. In it there are long struts which connect the jacket and core of the missile. The angles at the tip of the missile were chosen so that the angle between the conical tip of the missile and the head wave should be as large as possible rather than on the basis of our theoretical knowledge concerning the arrangement of the shocks for attaining maximum pressures. (See tables 1 and 2.) This is supposed to permit us to introduce the entrance cross section F_e in the best possible manner within the shocks which emanate from the tips of the missile and the suction slot. New difficulties which arise must be eliminated first of all. In the new model the throat consists of a Laval nozzle whose smallest cross section F_D

has the form of a cylinder of diameter h ; the axis of the cylinder coincides with that of the missile. Naturally this arrangement is completely unsuitable for practical application. In our experiments it was important to be able to set up the cross section F_D as exactly as possible and thus to assure not only a precise evaluation of the experiments but also their reproducibility. Since a micrometer scale was put on the part of the throat which could be screwed on, the value of h could be read to 1/20 millimeter without difficulty. On the other hand there is no doubt that sonic velocity prevails in the cross section F_D in the region which is most important for us. The pressure in the free stream was about 25 millimeters of mercury. In the measuring chamber the pressure was always somewhat higher, but it is certain that the pressure in the vicinity of the throat was not greater than in the suction reservoir of the apparatus. It was never more than 100 millimeters of mercury. Since the pressure in the combustion chamber was always over 270 millimeters of mercury, the pressure ratio was certainly always supercritical. The high accelerations, which the gas experiences on leaving the combustion chamber through the narrowest part of the throat, assure a flow in the entire region of the Laval nozzle to beyond the narrowest cross section. Hence, the function of the throat as a Laval nozzle with sonic speed in the narrowest cross section cannot be doubted.

The suction line A-L was therefore chosen this large so that the core of the missile should not be unnecessarily heavy. Suction into the measuring chamber takes place through a calibrated adjustable valve. The volume which was sucked off could always be determined with sufficient precision from the pressure measured in the suction line and the valve opening. When the suction was turned off a plate was clamped into the suction slot. As a result the suction slot itself is never visible in the schlieren photographs.

The quantities which were most important for practical purposes were measured, namely, the static pressure and the pitot pressure at the end of the combustion chamber, but sufficiently far ahead of the throat so that it could not have any important effect on the velocity distribution at the point of measurement.

Naturally care was taken that the measurement should not be carried out in the wake of a strut. If the setup functions well, and there is a smooth flow through the combustion chamber, then there are no important velocity components perpendicular to the axis of the missile in the vicinity of the measuring point, and hence, the static pressure directly over the measuring chamber must be constant. The pitot pressure could be measured at all points in the cross section of the pressure orifice for static pressure. First, the pitot tube could be shifted perpendicular to the axis of the model; second, it could be moved at will together with the orifice for static pressure around the axis of the model. The absolute static pressure was measured with mercury U-tubes, and the difference between the static pressure and the pitot pressure was measured with water manometers.

All these experiments were carried out in the 13- x 13-centimeter supersonic tunnel of the Institute for High Velocity Problems of the Aerodynamic Research Laboratory Göttingen e. V (Professor Walchner). This is a low-pressure tunnel of the usual type wherein the air is sucked from the laboratory through a drying filter, through a Laval nozzle and a measuring chamber and into a low-pressure reservoir.

The cross section of the combustion chamber in our model was chosen so that the flow there can be considered incompressible. Principally this permits as complete combustion as is possible without having too long a combustion chamber. For the velocity in the combustion chamber w we can use the Bernoulli equation. If we think of the velocity as made dimensionless by the velocity of sound at the stagnation point c^0 , we arrive at formula 25. For our experiments we can set the speed of sound at the stagnation point c^0 equal to the speed of sound in the combustion chamber c . Thus the ratio w/c^0 is, in our experiments, none other than the Mach number in the combustion chamber. (But we must note that this no longer holds if combustion takes place since combustion causes c to rise.)

$$\frac{w^2}{c^0^2} = \frac{2}{k} \frac{p_p - p_{st}}{p_p} \quad (25)$$

Here p_{st} and p_p are the static pressure and pitot pressure in the combustion chamber.

Under ordinary meteorological conditions the stagnation temperature for a free-stream Mach number $Ma_0 = 2.9$ is approximately equal to $T^0 = 800^\circ$ absolute and the corresponding velocity of sound is about $c^0 = 570$ m/s. As is known this is independent of whether the compression shocks are ahead of the stagnation point or not, only assuming that we are dealing with an ideal gas. If we are interested in the density in the combustion chamber, we can easily calculate it from the temperature and static pressure, where we can set the combustion-chamber temperature equal to the stagnation temperature with sufficient exactness. In the evaluation all pressures are made dimensionless by the total pressure p_0^0 of the free flow, that is, that pressure which is achieved by isentropic compression of the free-stream air at a velocity $w = 0$. For our experiments p_0^0 is that pressure which prevails behind the dehumidifying filter; because of the pressure drop in the filter it is always somewhat smaller than the barometric pressure.

Considering the size of the model in comparison to the cross section of the jet, it was not possible to set up the same pressure in the measuring chamber of the tunnel as in the exit cross section of the tunnel nozzle. But since it was only important to keep the flow characteristics clean in the vicinity of the head of the missile, it was necessary only to be sure that the nose of the missile was moved sufficiently close to the nozzle, possibly even somewhat into it but still far enough away so that the weak oblique compression shocks emanating from the edge of the nozzle, because of the high pressure in the measuring chamber, first hit the model a bit behind the entrance cross section F_0 . If this was not done, then it did not happen that there were deviations in the measurements of the order of magnitude of the difference between the chamber and the nozzle pressure, but rather the flow was completely altered and the static pressures in the combustion chamber fell to about 40 percent of the values which were measured with the proper arrangement. We shall return to this important phenomenon in our discussion of the experiments.

The majority of the measurements were made for a free-stream Mach number of $Ma_0 = 2.9$, in particular, the experiments with suction and the pitot-pressure measurements over the section of the combustion chamber. The most important experiments were repeated for $Ma_0 = 3.16$ and $Ma_0 = 2.62$. The Mach number in the jet was determined simply from the nozzle pressure, which can be done without complications for dry air.

5. EXPERIMENTAL RESULTS

In general our experiments were carried out so that the pressures p_{st} and $p_p - p_{st}$ were measured for increasing throat opening F_D . For this we had expected something like the following. When the throat is closed there will be no flow through the missile. There is an oblique compression shock starting from the tip of the missile and one from the suction slot. Ahead of the opening F_e , just as ahead of a pitot tube, there is a normal shock behind which the air flows off to the side without entering the missile. Under these conditions there must be a pressure within the missile which is significantly higher than the pitot pressure in the free stream (cf. problem 1). Now if the throat is opened somewhat, then part of the air behind the normal shock can flow into the interior of the missile, and the rest must still flow off to the side. As the throat opening increases, nothing changes qualitatively up to that opening for which the mass flow is exactly equal to the mass which would flow through the cross section F_e even if the entire jacket of the missile were removed. At this point the jacket of the missile is no longer a disturbing influence upstream. Indeed, oblique compression shocks go downstream from the leading edge of the jacket, but otherwise the flow enters the missile at supersonic velocity. In the subsonic diffuser it then falls abruptly to subsonic velocity in a practically normal shock, as has been known for a long time from experiments on Laval nozzles. (See L. Prandtl, *Führer durch die Stromungslehre*, p. 249, figs. 224 to 226.) If the throat is now opened still further, the mass flow remains unchanged for upstream from the cross section F_e the

flow is always the same. Opening the throat still further only causes the normal shock in the subsonic diffuser to move further downstream, and the combustion chamber pressure falls correspondingly. (See fig. 7.)

Accordingly we had two flow conditions which were fundamentally different: one with a normal shock ahead of the cross section F_e and with increasing mass flow as the throat is opened, and one with constant flow ahead of the section F_e and, hence, with constant mass flow and a normal shock in the subsonic diffuser. Here the pressure falls in the combustion chamber as the throat is opened. The position of the throat for which a normal shock occurs in the subsonic diffuser near the cross section F_e can be rather accurately determined without knowing the exact flow data. If we assume that on entering the missile and ahead of the normal shock the flow has a Mach number of about $Ma = 1.5$ to 2.0 , then the Mach number behind the shock amounts to about $Ma = 0.70$ to 0.58 . From this the cross section at $Ma = 1$ can be calculated for isentropic compression. It is about $0.83F_e$ to $0.91F_e$. Now in any case, the compression in the subsonic diffuser is not purely isentropic, and about 10 percent of the total pressure is lost, so that the throat opening F_D must be about $0.91F_e$ to $1.00F_e$ if the normal shock is in the beginning of the subsonic diffuser. This can be predicted so well without flow data because the Mach number behind the normal shock does not depend very much on the Mach number ahead of the shock and the flow cross section changes very little for Mach numbers near 1.

The optimum point at which the compression shock enters the missile we shall call the critical flow. (There is hardly any danger of confusion although the conditions in the narrowest part of a Laval nozzle at a Mach number $Ma = 1$ are also called "critical conditions.") Subcritical flows are characterized by the fact that the mass flow increases as the throat is opened. The drag of the missile is rather high in this case since a compression shock is situated ahead of F_e . Supercritical flow has constant mass flow, and combustion chamber pressure falls as the throat is opened. The drag of the missile is to be assumed to be smaller than in the subcritical range.

Figure 8(a) shows the static pressure in the combustion chamber; figure 8(b) shows the velocity in the combustion chamber (calculated for formula (25) from the pitot pressure and the static pressure) as a function of the ratio of throat area to entrance area F_D/F_e .

In the free-stream region $Ma_0 = 2.9$. The measurements come from several series of tests. If we now consider the static pressure, we see that as the throat is opened it rises to a maximum at an abscissa of about $F_D/F_e = 0.90$.

After that the pressure again falls as the throat is opened further. This point where the pressure is a maximum is therefore to be considered as the critical point. While the measured points are not scattered very much in the supercritical region, very considerable differences occur in the measured values in the subcritical region. It also appears as if several conditions of flow were possible in the subcritical region and even at the critical point itself. If we draw curves through the measured points in the subcritical and supercritical regions, they are obviously discontinuous at the critical point or at least they meet at an angle. While the ratios for throat openings F_D/F_e are as we expected, the sharp rise of the static pressure for $F_D/F_e < 0.90$ as the abscissa increases contradicts our prediction. According to the expected position of the compression shocks, a slight drop of the static pressure up to the critical point would have been expected, or else that the value would remain constant from about $p_{st}/p_0^0 = 0.54$. The pressure which can be attained with a pitot tube in the free stream is indicated by a straight line for $p/p_0^0 = 0.36$. For a missile with a simple opening in its nose this pressure could never have been completely attained because of the losses in the subsonic diffuser. The pressures in the combustion chamber in the vicinity of the critical point are therefore very much greater than those values which can be achieved with only one normal shock.

Since the drag in the supercritical region is smaller than in the subcritical region, the supercritical region primarily is to be considered for practical purposes. Fortunately the experimental values are only slightly scattered at this point, but there is still another advantage. Combustion has a displacing effect.

Correspondingly all cross-sectional areas upstream from the combustion must be made larger than those given for our model. If the combustion has not yet started, then the interior of the combustion chamber is well within the supercritical condition of flow. When the combustion starts, it acts like a contraction of the throat. And, hence, the pressure in the combustion chamber must rise, which causes the combustion to increase and brings about a further rise in pressure. We must only be careful that the amount of fuel which is injected is such that we never exceed the critical point. If this happens, it causes a drop in the combustion chamber pressure with increasing drag and, hence, a sharp decrease in velocity. Our considerations show that the subcritical region of flow is of little interest for us. Nevertheless, we shall try to explain extensively the relationships which occur there.

TABLE 3.- PITOT PRESSURE AND STATIC PRESSURE AS A
FUNCTION OF THE THROAT OPENING $Ma_0 = 2.9$

F_D/F_0	p_{st}/p_0^0	p_p/p_0^0	F_p/F_0	p_{st}/p_0^0	p_p/p_0^0
0	0.413	0.410	0.833	0.576	0.580
.185	.419	.416	.962	.534	.539
.370	.424	.421	1.036	.498	.504
.555	.456	.446	1.110	.466	.474
.740	.519	.508	1.295	.403	.411
.814	.594	.597	1.480	.357	.368

Table 3 shows the test results of a single series of measurements. From it we get the remarkable picture, that the pitot pressure in the subcritical range is often less than the static pressure. This was observed for all tests with closed or slightly open throat. The reason why the pitot tube can give lower pressures than the static pressure can be sought only in the fact that the pitot tube is at an angle to the flow or else the flow is not stationary.

Even when the pressure was measured, it was very remarkable that in the subcritical condition of flow in

the test chamber there was always a very characteristic humming sound while in the supercritical range nothing similar could be heard. From this it could be concluded that there were some periodical or nearly periodical processes. Moreover, in the subsonic range the mercury and water columns in the manometers were always subject to small variations. The vibrations of the compression shocks has also already been observed in many preliminary experiments. We made schlieren photographs, therefore, using a spark light source in order to get the flow condition at different instants. Figure 9 shows nine such photographs. Photographs 1 to 3 were made with the same throat position in the subcritical range, and 4 to 6 with two different throat positions in the supercritical range. If we now consider the photographs in the supercritical range, we always see one and the same picture in the vicinity of the nose of the missile. The two bright streaks which come out of the undisturbed free-flow region (especially clear in photographs 7 to 9), are the oblique shock waves which emanate from the edges of the nozzle. The side edge of the nozzle is visible as the edge of the picture on the left. The nose of the model is thrust somewhat into the nozzle in order that the shock waves of the edge of the nozzle should meet the missile as far back as possible. Hence, we cannot see the flow at the tip of the missile itself, but this is of little interest for us. It can be seen very clearly that no compression shocks start from the suction slot where the cone has an angular change of direction, but that this concave angle is bridged by a boundary layer. But for this reason very clear oblique shocks start from the beginning and end of this small dead area, and this can aid the effect of the angle since because of it the loss of total pressure is only lowered with this increase in pressure. It appears as if a normal shock stands ahead of the entrance E_0 , but this is certainly

due to a fault in the three-dimensional picture. The compression shock which we see emanating from the outside edge of the entrance must be thought of as rotating about the axis of the missile. The straight streak parallel to the entrance is therefore the part of the ring-type compression shock which is arched furthest forward. It is obviously a conical shock within the missile. For a new missile shape we would have to take care, in any case, that this compression shock should extend downstream at the sharpest possible angle from

the outer edge of the opening rather than arch outward. This is important in order to decrease the drag.

If we consider the three photographs 1 to 3 of the subcritical condition, we find different flow pictures on each of them. Photograph 1 is not essentially different from a picture of the supercritical condition of flow. For photograph 2 the air obviously flows out of the interior of the missile while in photograph 3 above we have supersonic flow like that of figure 1 and as can be seen from the bright line emanating from the suction slot, subsonic velocity prevails below. Thus, with subcritical flow we are dealing with a very complicated unstationary flow for which the interior of the missile is alternately filled with air up to a certain pressure and then part of this air is again forced out against the general direction of flow. During this process part of the air always flows through the missile, the amount depending on the throat opening. Under these conditions we should not wonder if we get badly reproducible measurements for which the negative pitot pressures are also observed.

These are the conditions then: While we invariably predicted the processes correctly in the supercritical flow, our expectations are not realized at all for subcritical flow. Here no stationary condition is set up and our measurements are reports of a series of different conditions. The reports, which are made of the pitot pressure and by the orifice for static pressure, are naturally very much different and formula (25) is in no way applicable to this mean value.

In addition we must also expect a slight variation in the values inside the combustion chamber with the supercritical condition. Indeed, the flow remains completely stationary right up to the normal shock in the subsonic diffuser but, according to our experience, it will vary back and forth about a mean position, and this must lead to small variations in pressure within the combustion chamber. It is not to be expected that formula (25) will be completely valid in the supercritical range either.

Moreover we have a sure control for this formula. Since we know the Mach number in the narrowest section

of the throat - it is always $Ma = 1$ - and, since, we also know the ratio of the combustion chamber cross section F_D to the throat cross section, the Mach number in the combustion chamber can be calculated. Here again we take the velocity w divided by the velocity of sound in the stagnation point c^0 instead of the Mach number. The condition of continuity is

$$F_D w \rho = F_D^* w^* \rho^*$$

But because of the low velocity the density in the combustion chamber can be set equal to the density for $w = 0$. Hence ρ^*/ρ is to be considered at the critical density ratio $\rho^*/\rho = 0.63$; $w^*/c^0 = 0.91$ (for $k = 1.400$) and, consequently,

$$\frac{w}{c^0} = \frac{w^*}{c^0} \frac{\rho^*}{\rho} \frac{F_D}{F^*} = 0.173 \frac{F_D}{F_e} \quad (26)$$

Thus, we see that the velocity in the combustion chamber depends only on the temperature in the combustion chamber (because of c^0) and the geometric ratio F_D/F_e . The straight line (26) is shown in figure 8(b). The velocity calculated from formula (25) with the aid of the pitot and the static pressures generally lies somewhat below the values of (26) in the supercritical range. But considering the precision which was established for determining the velocity in the combustion chamber, the variations are entirely meaningless. On the other hand the variations in the subcritical range are very large. Here the values which formula (25) gives are certainly false. While in the subcritical range the variation of the pressure in the combustion chamber is certainly responsible for the deviation of the measured points from the straight line of equation (26), in the supercritical range there is also the question of whether the assumption, that exactly the speed of sound prevails in the narrowest part of the throat, is completely satisfied. As is known, this holds only if the radii of curvature of the nozzle walls are large compared to the nozzle opening.

The volume of air flowing through the missile is of very great interest from the point of view of

combustion. The important factors for the amount of mass flow are the density of the air and the velocity of the air in the free stream. Now these are very much different in an experiment from what they really are, and so there is not much sense in giving the mass flows which occur in the experiments. It is better to choose a value which is independent of the particular density and velocity in the free-flow region - a value which therefore depends only on the shape of the missile and on the free-stream Mach number. For it, we choose the ratio of the cross section F_o , which includes the air

in the free-stream region which flows through the missile, to the entrance cross section F_e . If we indicate all values in the free-stream region by the subscript o and the mass flow by G , then the following condition of continuity must be satisfied:

$$G = \rho_o w_o F_o = \rho^* w^* F_D$$

The density in the throat ρ^* is now not approximately equal to the critical density $0.53\rho_o$ appropriate to the free-stream density, but rather it is smaller by the loss of total density. But since the total temperature T^o is always the same, the ratio of total density in the combustion chamber to the total density in the free stream is equal to the corresponding pressure ratio p_p/p_o . Subsonic velocity prevails in the combustion chamber and so the total pressure itself is measured by the pitot tube. Hence, we can write

$$\frac{F_o}{F_e} = \frac{F_D}{F_e} \frac{p_p}{p_o} \frac{\rho^* w^*}{\rho_o w_o} \quad (27)$$

$\rho_o w_o / \rho^* w^*$ is the ratio of the flow cross section in the free-stream region to the flow cross section for $Ma = 1$ assuming that conditions change isentropically. This ratio depends only on Ma_o and for

$$Ma_o = 2.9$$

it is

$$\frac{\rho_o w_o}{\rho^* w^*} = 0.26$$

In order to get the true mass flow, we need only to multiply the flow cross section F_o by the free-stream density and the free-stream velocity.

In figure 8(c) the cross-section ratios F_o/F_e are shown as functions of F_D/F_e . In the supercritical range F_o/F_e must also be constant because of the constant mass flow. As we see this also fits in well. The small increase of our values for the mass flow in the supercritical range should be due, just as the deviations in the velocity values under conditions which have already been mentioned, to the fact that it is not entirely correct to assume constant condition in the narrowest part of the throat for wide openings, and that the pressure measurement is not completely exact due to the small variations which occur. The numerical values show that approximately twice the surface of the circular opening F_e is scooped up from the free-stream air. Hence, this is just twice as much as we could expect to attain with a simple hole of size F_e in the nose of the missile. While the air experiences no change of condition ahead of the entrance into the missile in the latter case, in the case of the shock diffuser the cross section of the flow is already decreased by compression shocks ahead of F_e . (See fig. 7.)

We can also make use of the fact that the mass flow is independent of the throat opening in order, with the aid of formula (27), to give the pitot pressure in the combustion chamber as a function of the ratio F_D/F_e , if we know the pressure for only one throat opening. As the curve showing this relationship, we obviously get a hyperbola. This permits us to extrapolate the pitot pressure in the combustion chamber somewhat beyond the measured range.

We could now question whether the values, which we have measured, occur only at the measured point itself and perhaps differ considerably from it at other points. In order to go on with more sureness, the velocity profile at one station of the combustion chamber was first measured. This was readily possible since the pitot tube could be shifted in a radial direction. Table 4 gives the results for two throat positions. In

all five positions were measured. As we see the results are satisfactory throughout.

Greater deviations are to be expected if we measure in a circle in the center of the combustion chamber. For we cannot assume that the normal shock is in the same position everywhere in the subsonic diffuser. These measurements were carried out for four positions. In figure 10 the cross section of the combustion chamber is indicated by the four measured places. Here too we see no substantial deviations. (Since the values frequently lie rather close to one another, it is not always directly obvious which position is given by a certain point. But since for each P_D/P_e all four positions were always measured, it can always be readily stated, how the individual points are covered.)

Moreover several measurements were made with an angle of attack of the missile to the direction of flow of about 4° . In these measurements pitot pressure and static pressure were measured in the four positions of the tests just described. The throat position was near the critical position. Here too there were no real deviations. The highest pitot pressure in the combustion chamber seems to appear at times on the lee side. Moreover, between the other measurements the model has often been taken out of the channel and when it is put in again is always adjusted with the naked eye alone. Nevertheless, in the supercritical region only slight deviations appear in the measurements. This too indicates a certain insensitivity of the device toward small angles of attack.

Besides the measurements for $Ma_0 = 2.9$ there were also measurements at $Ma_0 = 3.16$ and 2.62 (fig. 11). The exact same graph appears as for the previous measurements. Thus, with a higher Mach number the total-pressure losses are naturally larger. But if we measure the combustion-chamber pressure in multiples of the pressure of the flow, we naturally arrive at higher combustion chamber pressures for higher Mach numbers. Our tests show that the critical point is always at about the same throat opening, which was to be expected. This is really important in practice. That is, it is not dangerous to

TABLE 4.- VELOCITY PROFILE IN THE COMBUSTION CHAMBER FOR
 $F_D/F_e = 0.92$ AND 1.48

	$F_D/F_e = 0.92$	$F_D/F_e = 1.48$
Outer wall	$w/c^0 = 0.145$	$w/c^0 = 0.272$
One-fourth of the way in	0.143	0.273
Middle	0.146	0.241
Three-fourths of the way in	0.144	0.254
Inner wall	0.151	0.264

come into the subcritical region, if the missile is flying at a Mach number somewhat different from the one provided. Now we have singled out the values of p_{st}/p_o^0 when $F_D/F_e = 0.89$ and they are plotted in figure 1.

We see that the points lie rather close to the curve $n = 2$. Thus, the solid curve for $n = 2$ also gives a reference point, by means of which pressure recovery can be calculated for significantly higher or somewhat lower Mach numbers. For Mach numbers less than 2 the curve no longer offers accurate values, since boundary-layer effects then begin to play a greater role.

The fact that our points are so close to curve 2 shows theoretically, moreover, that we recover the pressure in at least two oblique and one normal shocks, as we have already recognized from the schlieren photos. Now if only one oblique shock were present then on account of the losses in the subsonic diffuser only about 90 percent of the values of curve 2 could be reached. Several other effects are added to this effect and they would be of lesser weight. A favorable effect is contained in the fact that an isentropic compression (compare, for example, R. Sauer, Gas Dynamics) always occurs in the conical flow. Thus, the parts which are nearly conical give a somewhat better recovery than the calculation shows, if we make shocks alone responsible for the pressure rise. Not in contrast to this is the fact that certain small losses must be accepted on account of the boundary-layer flow. It is noteworthy moreover that for our model the angles are in no event chosen so that the most favorable combination of shock waves is given directly. But this assumption underlies the calculation of the curves of figure 1.

In any event it is such that for not too great deviations from the required optimum shock-wave angles, no real deviations from the theoretical curves are to be expected. Now we are at a maximum here, and the values near a maximum are, as is known, insensitive toward slight deviations of the arguments.

The influence of these four effects can be arranged somewhat in the following order: First, losses in the subsonic diffuser; secondly, gains in the conical flow; thirdly, losses due to deviations from the optimum shock-wave angle; and fourthly, boundary-layer losses in the region of supersonic flow. The effects really depend upon the shape of the model. If the two effects mentioned in the middle are more carefully considered, it would surely be possible to even increase the effects with respect to our model. On the other hand the losses in the subsonic diffuser and in the boundary layer could even now be reduced to a minimum by means of the tests described.

We will not go far wrong if we assume that in a broad range the four effects mentioned are more or less independent of the Mach number. Very likely this is also the reason why the measured points are relatively well arranged in the curve system of figure 1.

Our proceedings show that near the critical point and in the supercritical region no better values for our model are to be expected than those reached in the tests. Thus, at least in the region where the missile functions well, we cannot expect much in the way of suction. We have carried out tests with four different openings of the suction valve. But the differences are slight, so that we show in figure 12 only the experiments with half opened or fully opened suction valve in contrast to those without suction. Along with the pitot pressure and the static pressure in the test chamber the volume of suction was also determined for each measurement. The results do not seem important enough for us to reproduce them all here. As the throat opening increases the suction volume decreases somewhat until the critical point is reached. As would certainly be expected it remains constant in the supercritical region. In figure 12 the ratio of suction volume to volume of flow G_{Ab}/G is always indicated for the supercritical region.

We see that in the region which concerns us, the suction is detrimental and, indeed, in spite of the small volume of suction an important drop in the static pressure within the combustion chamber results. Only in the subcritical range does it happen that the suction occasionally causes a rise in the static pressure. This effect was often present in the tests in the subcritical range without being reproducible with any complete certainty.

After all that has been said, it is not remarkable that the suction offers no advantage in the supercritical range. But in the subcritical range it does not appear to be sufficiently effective as opposed to the strong pulsations which occur.

In conclusion we shall treat briefly photographs 7 to 9. (See fig. 9.) Here the missile is not thrust sufficiently far into the nozzle so that the oblique compression shocks emanating from the edge of the nozzle meet the head waves of the missile in the vicinity of the cross section P_0 . The shocks emanating from the nozzle and from the missile combine in both the supercritical and subcritical range in approximately the same way into an arrangement of compression shocks which differs from the rest of the photographs. The pressure measurements show that this results in extraordinary poor pressure recovery for any throat opening. It is therefore very important for correct values to set up the model correctly with respect to the nozzle of the tunnel.

6. DISCUSSION OF SOME ADDITIONAL EXPERIMENTS

POSSIBILITIES OF FURTHER INCREASE OF PERFORMANCE

After carrying out all the experiments it seemed obvious to investigate the effect of a change in the nose of the missile on the pressure and velocity in the combustion chamber. The nose of the missile was altered as is shown in figure 13. The change was primarily considered in the sense of decreasing the drag. Moreover, there was the possibility of moving the tip into the interior of the missile. Four of this series of

tests are shown in figure 14. It is evident that, when the tip is not moved back, the values with the new form become somewhat worse. But moving the tip back again causes an improvement. When the tip is moved back 1.5 millimeters we get a maximum value of $p_{st}/p_o^o = 0.624$. This is not a single point, as might be supposed from the figure; other values approximately as great were measured, but they are not shown here. We should note that the value of F_o increases somewhat as the tip is moved back. By F_o in the fraction F_D/F_o we understand the entrance area appropriate to the position of the tip at that time. The velocity, which was measured but is not shown here and, also, the mass flow do not differ much from the value arrived at in the earlier tests.

It is therefore shown that the value when the tip is moved 1.5 millimeters back represents the experimentally determined maximum. Since the drag of the missile could be even smaller here than for the original model, this form would be preferable to the original form. There can be no doubt that the values at the various points of the combustion chamber do not vary here any more than for the nose of the missile which was tested first and, also, that the other characteristics have undergone no real change.

But from the last experiments we can see that the performance possibilities of the shock diffuser can surely be increased still more. Thus, these tests appear to be important primarily as an indication of this possibility of increasing the combustion-chamber pressures rather than as an improvement in the diffuser.

Hence, we should strive primarily to construct a new shock diffuser with the aid of the axially symmetrical characteristics method on the basis of the knowledge derived in the theoretical section concerning the optimum arrangement of oblique shocks. In this, the angle in the cone can be dispensed with in any case; it would be more pertinent to try to have an oblique compression shock emanate from the tip of the cone and also from the outer rim of the entrance area F_o and we must be careful that the tunnel behind the entrance area F_o is not constricted beyond the permissible limit. If we succeed

in constructing an arrangement while keeping the optimum shock angle - which, in any case, is not difficult mathematically - then for a Mach number of $Ma_0 = 2.9$, 90 percent of the value given under $n = 3$ (solid curve) in figure 1, that is, $p_{st}/p_0^0 = 0.90 \times 0.78 = 0.70$, must be attainable. At the same time we should take care to keep the drag of the model as small as possible.

7. SUMMARY

The problem of having oxygen available at maximum possible pressure for the rocket propulsion of a missile flying at high speed was solved in this way; the atmospheric air is first compressed at the nose of the missile in a compression shock cone and is then introduced into the interior of the missile through a circular opening. After still more compression by shocks, the air is slowed up until it finally reaches subsonic velocity. Further increase in pressure is effected by a subsonic diffuser through which the air reaches the combustion chamber. Theoretical considerations show that this method leads to significantly higher pressures than scooping up the air by a hole similar to a pitot tube in the nose of the missile. If certain rules are followed, the method which is described can be realized very well in practice. While the maximum pressure of the air in the combustion chamber which is theoretically attainable out cannot be reached in practice amounts to 31 atmospheres absolute for a missile flying in the free atmosphere at 2.9 times the speed of sound, a combustion-chamber pressure of only 11 atmospheres absolute can be attained using a simple duct in the nose of the missile. On the other hand the best results obtained in our experiments correspond to a combustion-chamber pressure of 19 atmospheres absolute. The experiments in the range which is of practical interest proved to be completely reproducible; also, the device proved it to be insensitive toward disturbing influences. A certain additional increase in the performance seems possible. The device was called a shock diffuser due to the type of pressure recovery.

Translated by Jack Lotsof and Robert Luippold
Curtiss-Wright Corporation

8. BIBLIOGRAPHY

1. Eggink: Strömungsaufbau und Druckrückgewinn in Uberschallkanälen. (Flow Structure and Pressure Recovery in Supersonic Channels.) ZWB-Forschungsbericht No. 1756.
2. F. Schubert: Zur Theorie des stationären Verdichtungsstosses. (On the Theory of the Stationary Compression Shock.) Z.A.M.M., vol. 23, no. 3, p. 152, June 1943.
3. A. Naumann: Wirkungsgrad von Diffusoren bei hohen Unterschallgeschwindigkeiten. (Efficiency of Diffusers at High Subsonic Velocities.) ZWB-Forschungsbericht No. 1705.

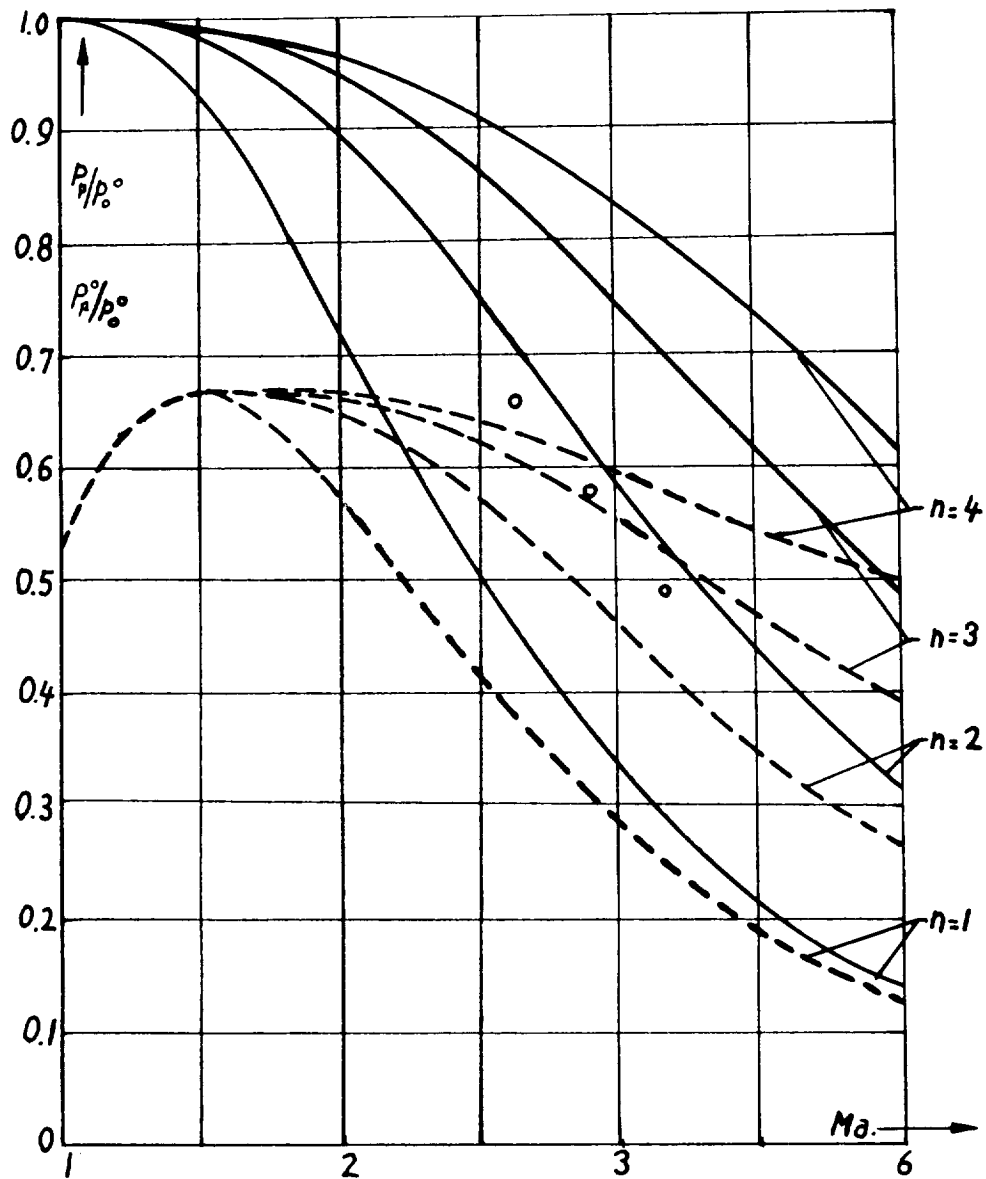

Figure 1.- Maximum possible pressure recover with n shocks.
 ——— maximum possible total pressure after n shocks.
 - - - - - maximum possible static pressure after n shocks.

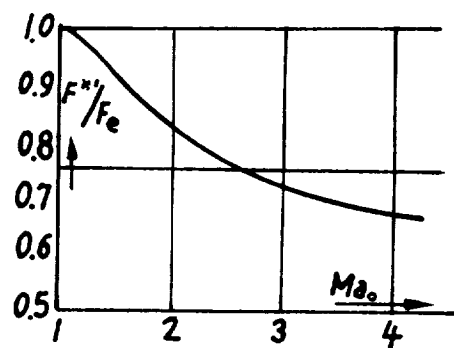

Figure 2. Theoretically permissible contraction, while avoiding normal compressibility shocks, as a function of mach number.

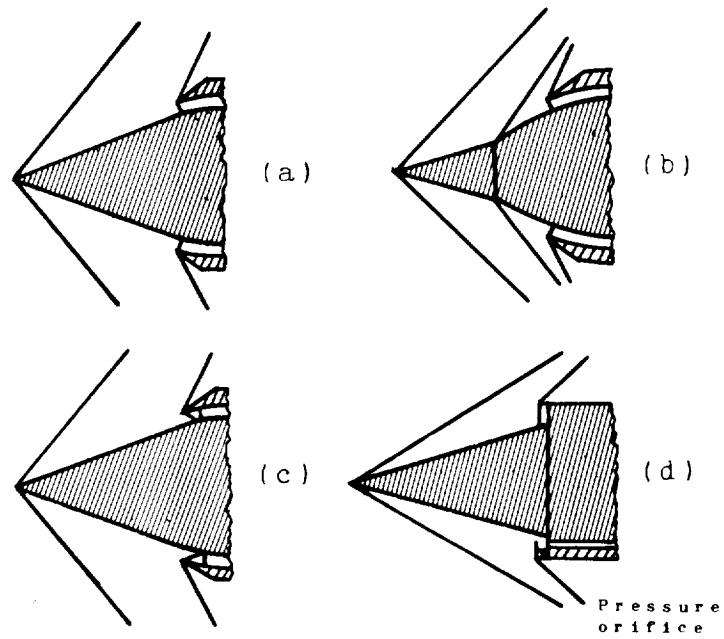

Figure 3. Sketches for the position of the shocks with shock diffusers.

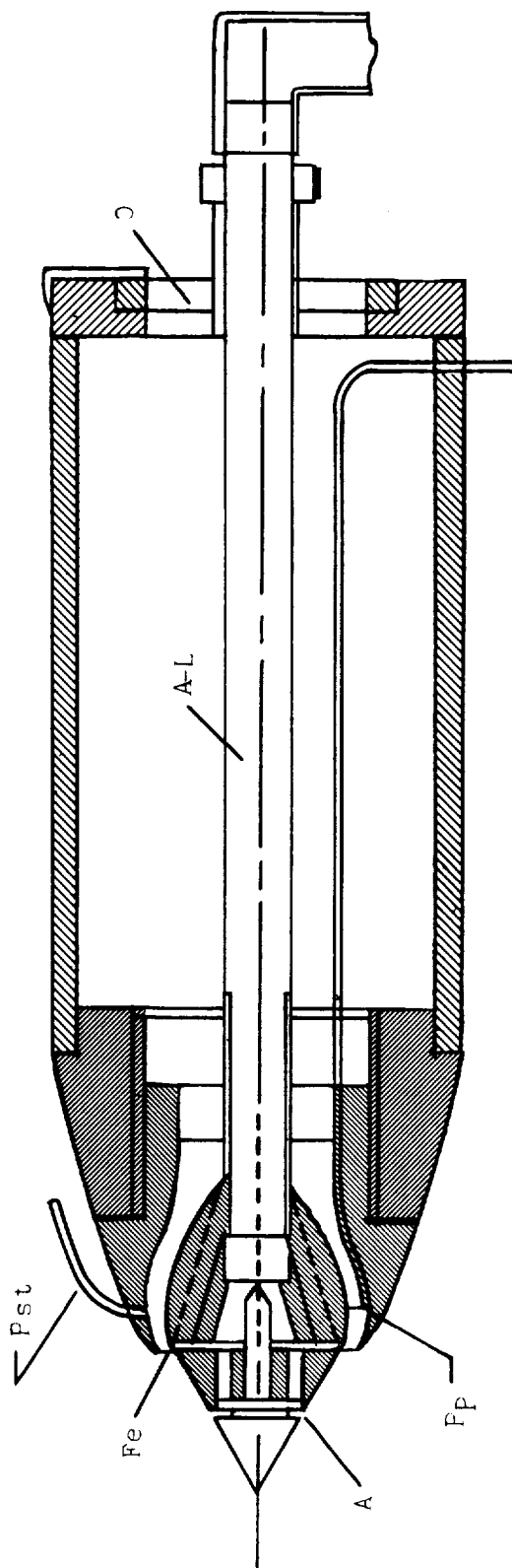

Figure 4. Drawing of a model used for the preliminary experiments.

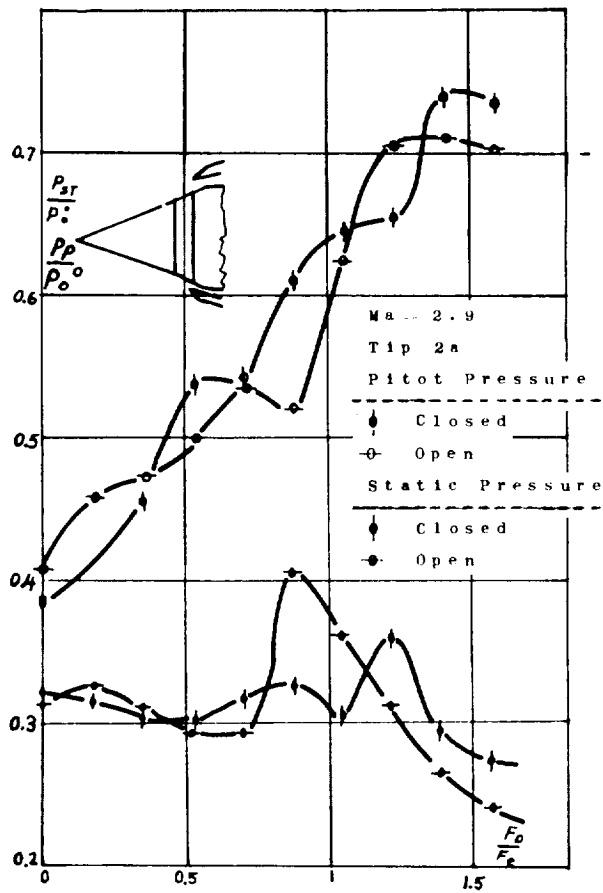

Figure 5. Experimental results for the model of Fig. 4. (Pitot pressure and static pressure directly behind the entrance cross section as a function of throat opening.)

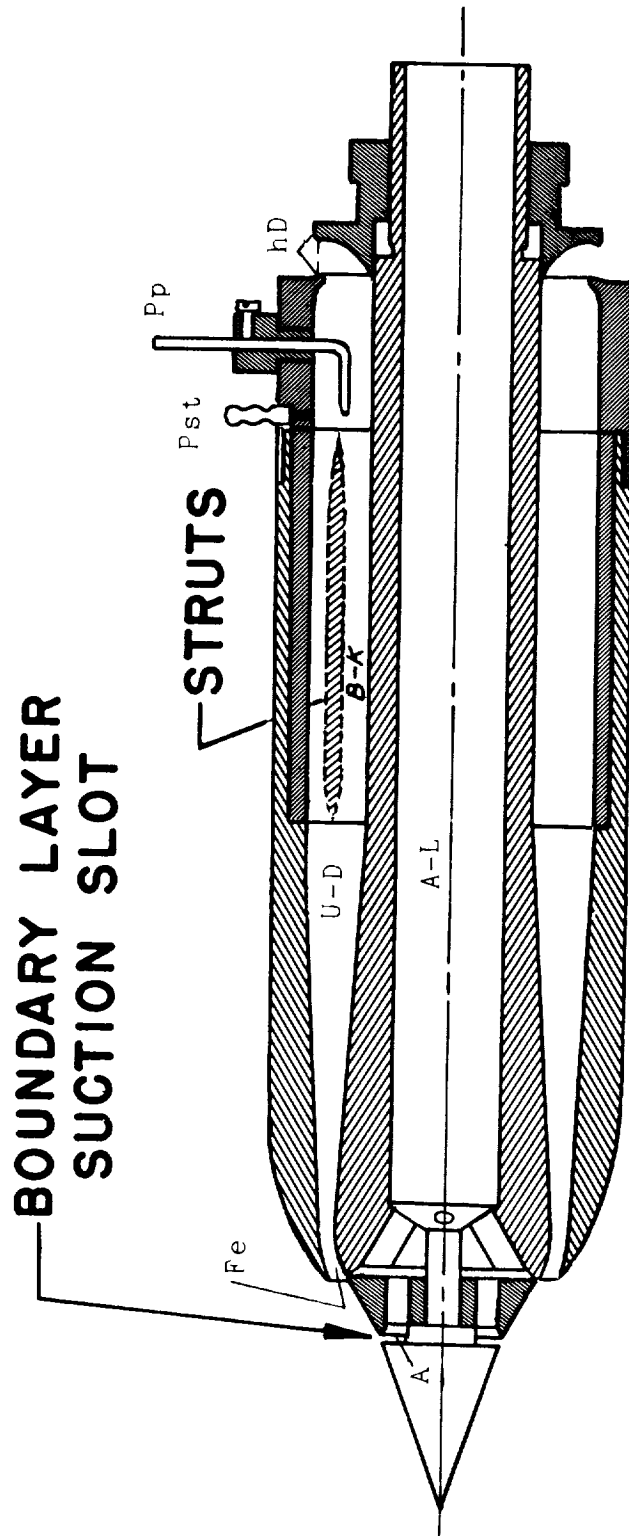

Figure 6. Scale drawing of the model.

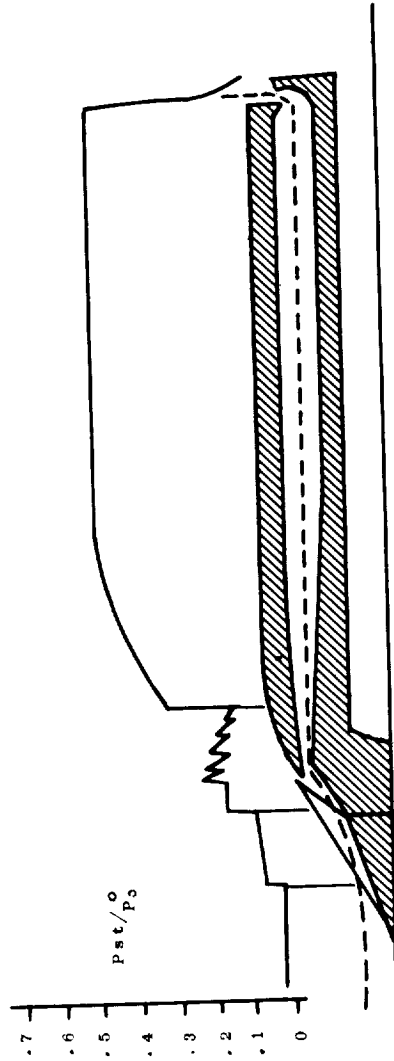

Figure 7. Supercritical flow condition (qualitative pressure curve along the dotted stream line).

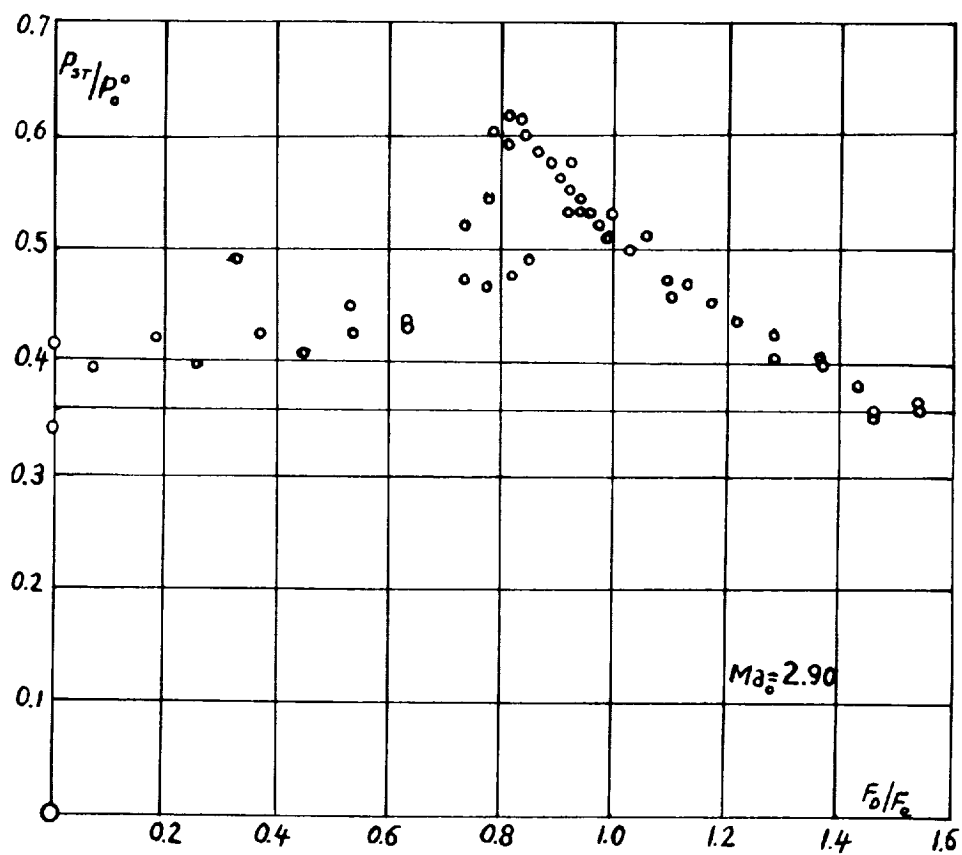

Figure 8a. Static pressure in the combustion chamber as a function of the throat opening.

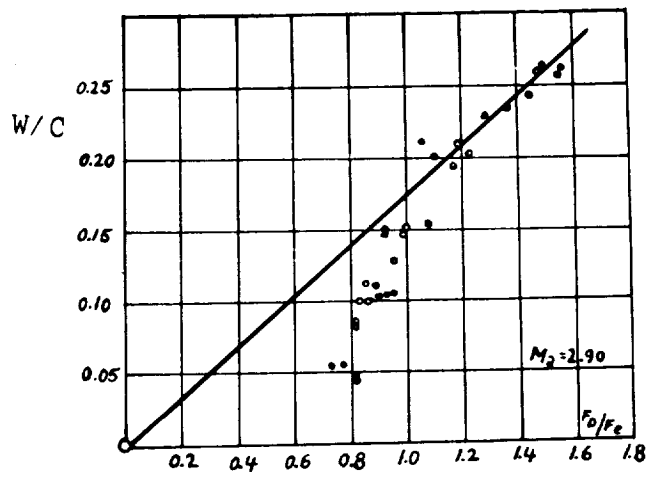

Figure 8b. Velocity in the combustion chamber as a function of the throat opening.

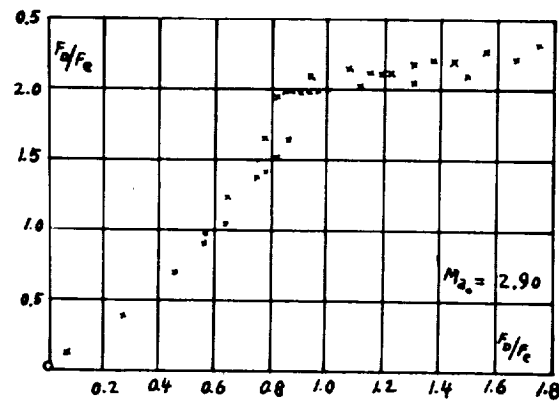

Figure 8c. Mass flow as a function of the throat opening.

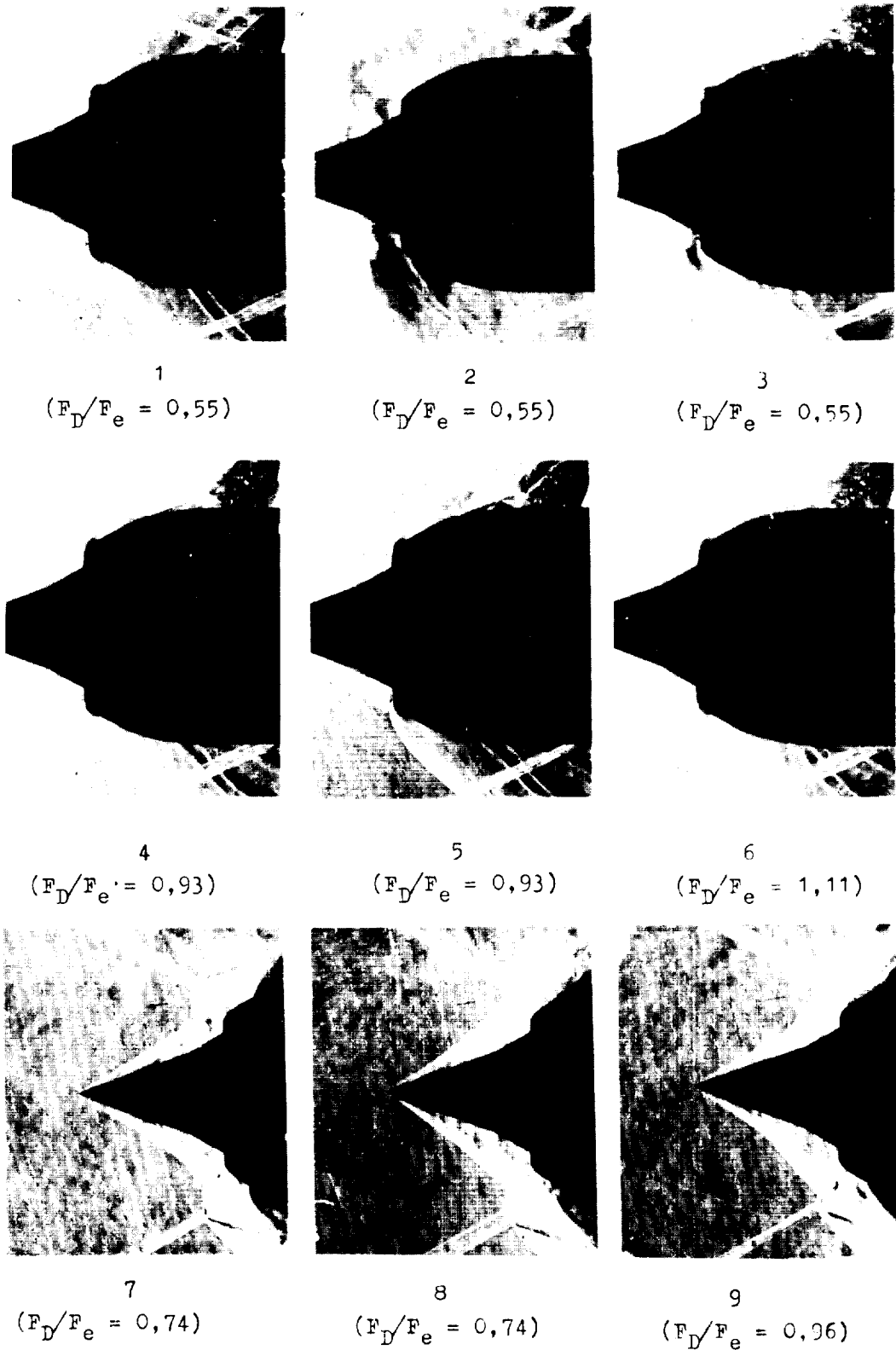

Figure 9. Schlieren photographs with spark light source at sub and supercritical flow and with poor position of the model.

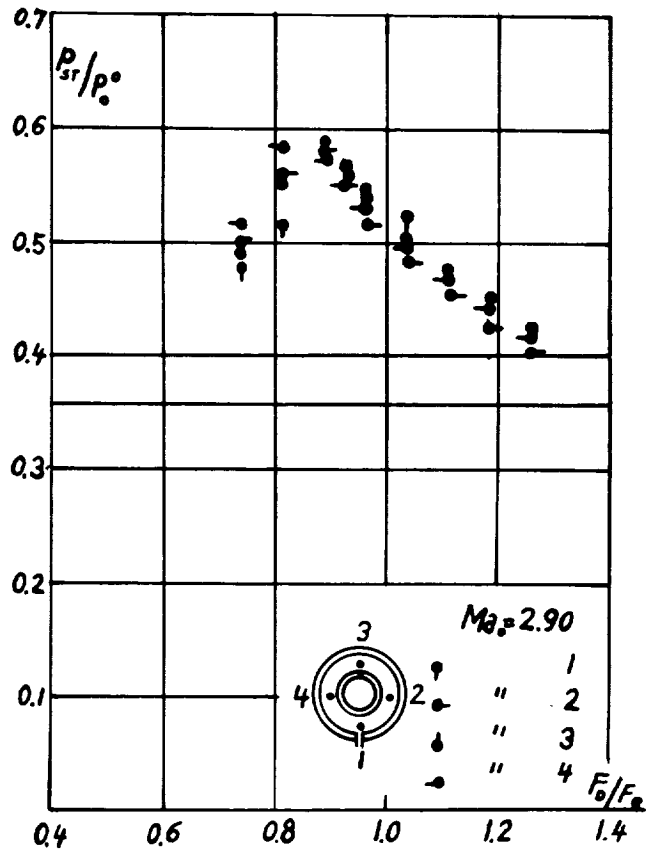

Figure 10. Pressure as a function of the throat opening at four different positions of the combustion chamber.

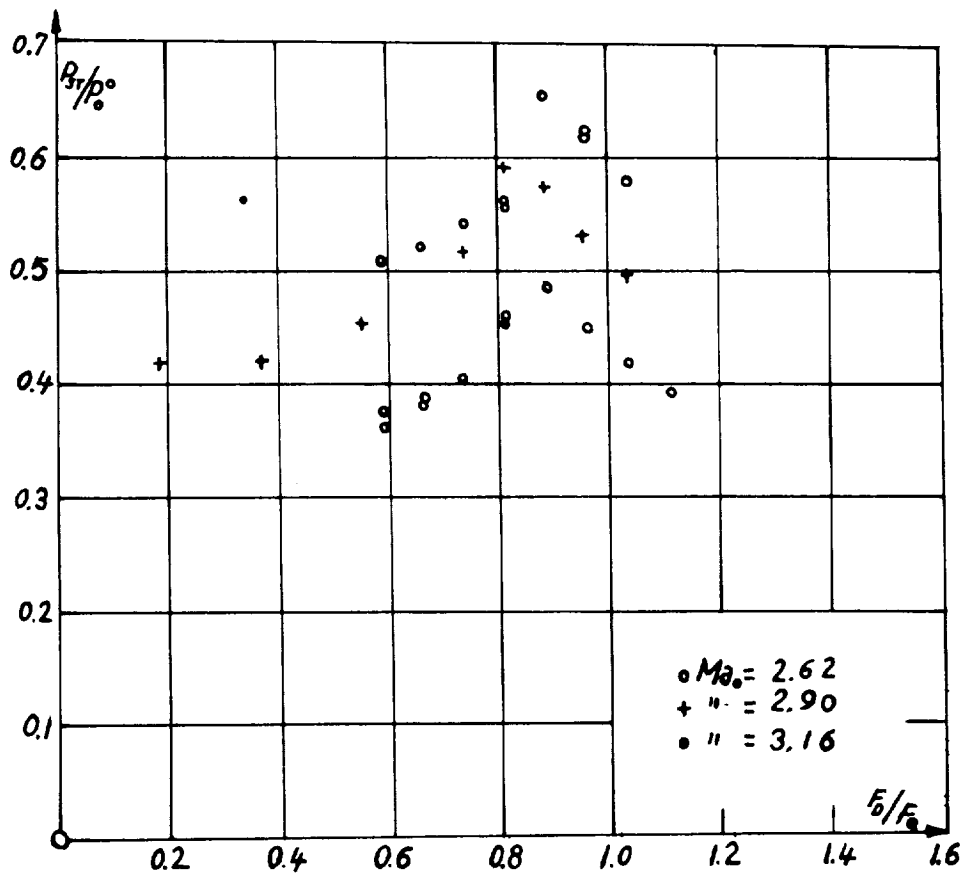

Figure 11. Pressure in the combustion chamber as a function of the throat opening for three different mach numbers.

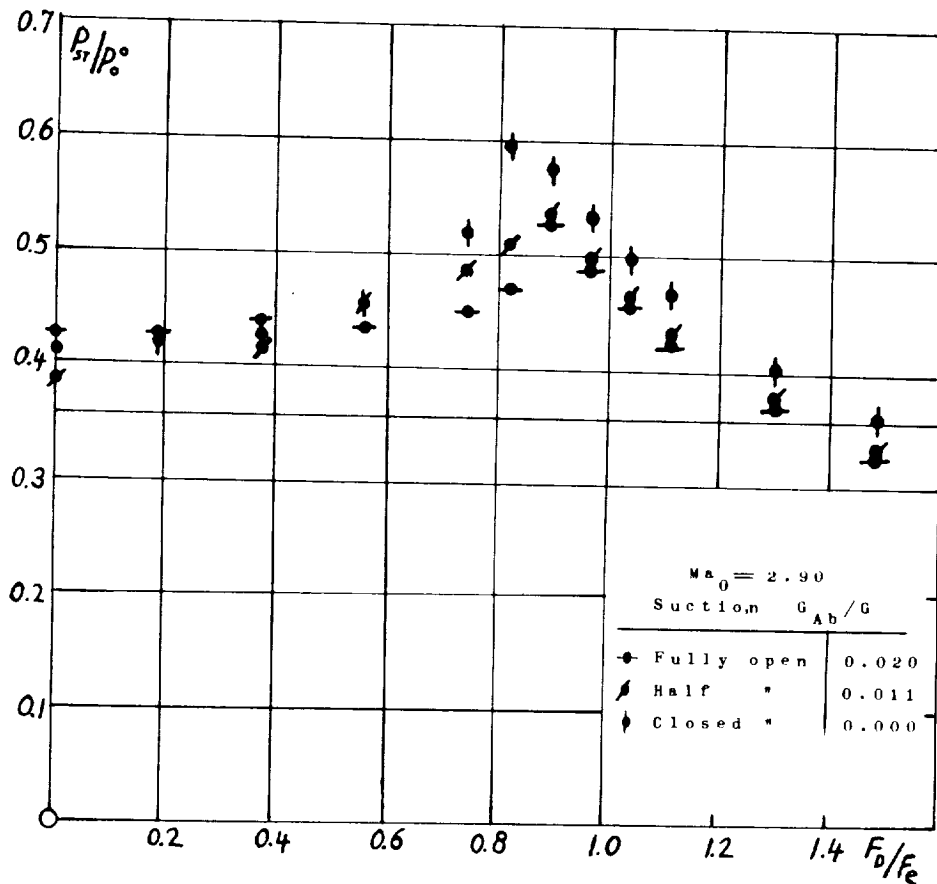

Figure 12. Pressure in the combustion chamber as a function of the throat opening with suction (G_{Ab}/G volume of suction in the supercritical range).

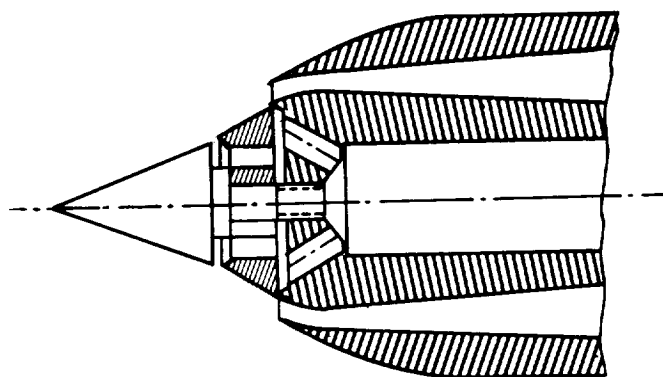

Figure 13. Altered form of the nose of the missile.

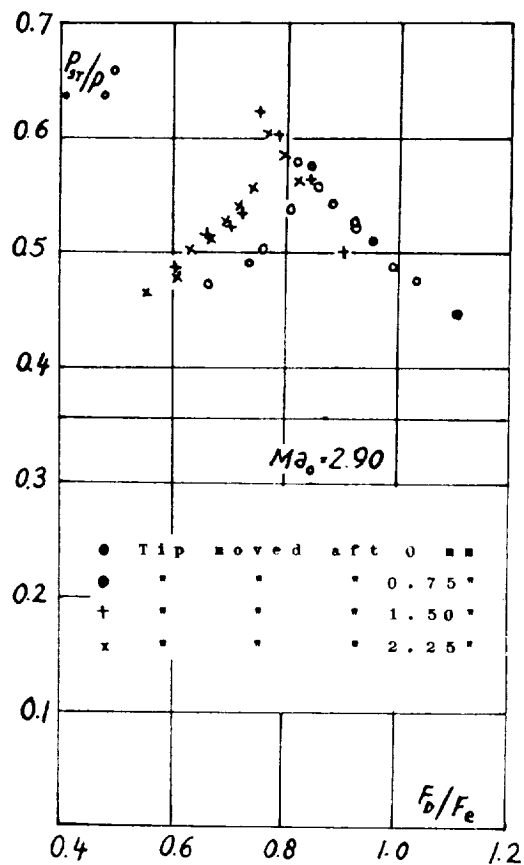

Figure 14. Pressure in the combustion chamber as a function of throat opening for the altered form of the nose of the missile, as in Fig. 13.