

# Design, Development, And Testing of Umbilical System Mechanisms for the X-33 Advanced Technology Demonstrator

Alan C. Littlefield and Gregory S. Melton

## Abstract

The X-33 Advanced Technology Demonstrator is an un-piloted, vertical take-off, horizontal landing spacecraft. The purpose of the X-33 program is to demonstrate technologies that will dramatically lower the cost of access to space. The rocket-powered X-33 will reach an altitude of up to 100 km and speeds between Mach 13 and 15. Fifteen flight tests are planned, beginning in 2000. Some of the key technologies demonstrated will be the linear aerospike engine, improved thermal protection systems, composite fuel tanks and reduced operational timelines. The X-33 vehicle umbilical connections provide monitoring, power, cooling, purge, and fueling capability during horizontal processing and vertical launch operations. Two "rise-off" umbilicals for the X-33 have been developed, tested, and installed. The X-33 umbilical systems mechanisms incorporate several unique design features to simplify horizontal operations and provide reliable disconnect during launch.

## Introduction

The two ground-to-flight umbilical connections for the X-33 vehicle are located facing aft on either side of the linear aerospike engines (Figure 1). The fuel umbilical provides thirteen connections to the vehicle, including liquid hydrogen supply and bleed lines, as well as high-pressure gases (up to 21 MPa), environmental control, hazardous gas sampling, electrical power, and data. The oxidizer umbilical provides seventeen connections to the vehicle, including liquid oxygen supply, high-pressure gases, environmental control, hazardous gas sampling, avionics cooling, electrical power, and data. The umbilicals are connected after the vehicle is mated to the rotating launch mount in the horizontal configuration and remain connected through rotation to vertical, tanking, and launch. The aft mounting of the umbilicals results in a "rise-off" type of disconnect that quickly subjects the ground half of the connection to the engine exhaust plume. Traditional vehicle configurations (with minimal aft area) have favored side-mount umbilical configurations which complicate the disconnect but provide additional time to protect the ground system from damage. The X-33 umbilicals are the largest rise-off umbilicals developed for any U.S. space system.

### Umbilical System Requirements

The requirements for the X-33 umbilicals were driven by the general vehicle configuration and design, as well as specific safety and operational requirements. The aft mounted umbilical "rise-off" configuration and fast acceleration of the X-33 off of the pad (0.9g) resulted in an available operating time of 1.4 seconds from first motion of the vehicle until the engine exhaust plume impinges on the ground umbilical. The umbilical must be disconnected and stored within a protective enclosure before the plume reaches any sensitive components. Operational timelines allotted only one hour to accomplish the entire mating operation. This resulted in a requirement for semi-automatic connection and leak check capability. The quick turnaround requirement for successive launches (24 hours) leaves little time available for refurbishment of ground systems. Misalignment of the vehicle on the launch mount, dynamic deflections of the structure, and drift of the vehicle during liftoff required accommodating relative motions between the ground and flight components of up to 4 cm. Early in the design, the customer imposed several

---

NASA, Kennedy Space Center, FL

*Proceedings of the 34<sup>th</sup> Aerospace Mechanisms Symposium, Goddard Space Flight Center, May 10-12, 2000*

additional requirements on the system. In order to reduce costs and refurbishment time, no pyrotechnic devices were allowed. To simplify the ground control systems and software, no T-0 signal from the vehicle or ground would be provided. This required the disconnect sequence to be initiated by liftoff motion of the vehicle only. Finally, all systems must operate on stored energy (springs, compressed gas, or gravity).

#### Umbilical System Description

The X-33 Umbilical system consists of a flight panel assembly and a ground umbilical assembly. The nominal size of the ground and flight connector panels is 89 cm by 127 cm. The fluid and electrical connectors are rigidly mounted to the panels. The flight panel assemblies (Figure 2) attach to the vehicle aft thrust structure adjacent to the engines and consist of a structural aluminum panel supporting the flight halves of the various connectors as well as receptacles for the panel alignment and locking mechanisms. A sliding door on each assembly closes after disconnect to protect the panel and connectors from heating and contamination during flight. The ground umbilical assemblies (Figure 2) attach to the rotating launch mount on the pad. The ground assembly is a protective tunnel structure containing the ground panel and mating, release, and retraction mechanisms. The umbilical tunnel weldment supports and protects the ground umbilical mechanisms. Blast doors on the tunnel close to protect the umbilical mechanisms from launch blast damage. A translating frame structure within the tunnel supports the ground panel on a six degree-of-freedom compliance mechanism and retracts into the tunnel during the disconnect. Fluid and electrical lines are routed through the translating frame and tunnel to an interface plate on the launch mount.

#### Umbilical System Operation

The operation of the umbilical can be divided into three phases. The first operational phase is mating of the umbilical in the horizontal mode (or vertical mode as a contingency). The second phase is the use of the various fluid and electrical systems throughout processing, rotation and tanking operations. The third phase is the actual disconnect of the umbilical following liftoff.

#### Mating Operations

The mating operation begins after the vehicle is attached to the launch mount. First, the flight door is manually opened and pinned to allow access to the flight panel. Next, the blast doors are opened and the translating frame assembly is extended using pneumatic jacks. As the jacks are extended, alignment pins on the ground panel engage the flight panel while the compliance mechanism supports the weight of the ground panel, hoses, and cables and allows the panels to align for mating. As the jacks are fully extended, the translating frame latches in the extended position. The jacks are then retracted to allow the latches to support the translating frame. Next, the alignment pins are retracted in parallel to mate all the fluid and electrical connectors. Finally, quick-release locks are pneumatically engaged to rigidly connect the panels.

#### Processing Operations

Throughout horizontal, rotational, and vertical operations, the compliance mechanism continues to support the ground panel, hoses, and cables (with a total mass of over 800 kg) to limit loads transferred to the vehicle. The quick release locks prevent separation of the panels due to fluid pressure forces between the connectors (up to 71kN total).

#### Disconnect Operations

Following completion of tanking operations, the cryogenic lines are drained, and power is removed from the electrical connectors in preparation for launch. Several pneumatic lines and the environmental control system remain fully or partially pressurized through disconnect.

The launch sequence begins as the vehicle engines are started. As the engines cause the vehicle and launch mount to deflect from their nominal position, the compliance mechanism absorbs relative motion (up to 2.5 cm) between the vehicle and the mount. The umbilical must remain connected during these deflections to ensure the capability to de-tank in the event of an abort. After the engines are verified to be

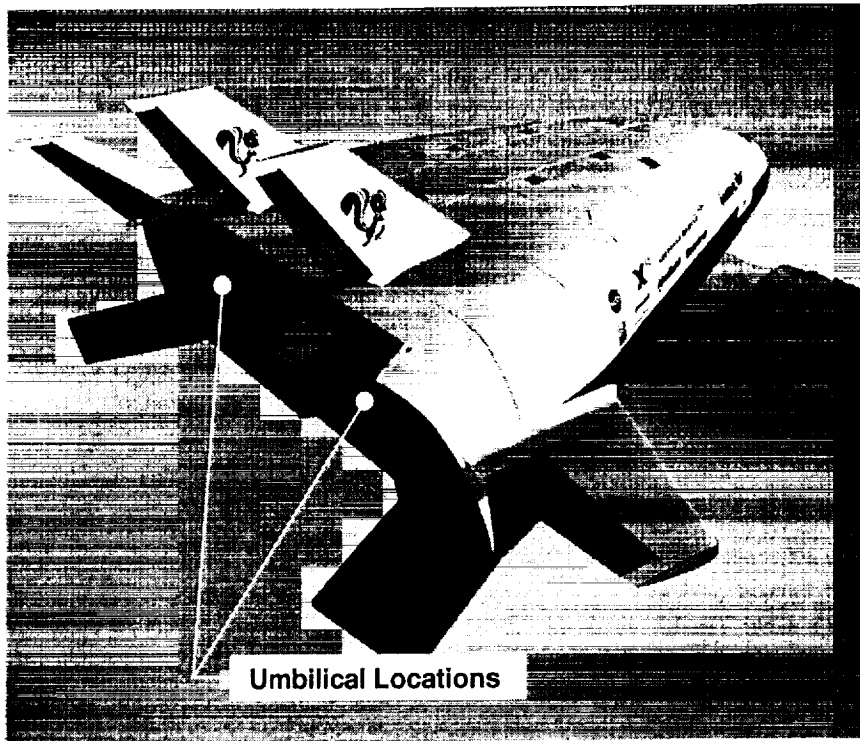

Figure 1. X-33 Vehicle Umbilical Locations

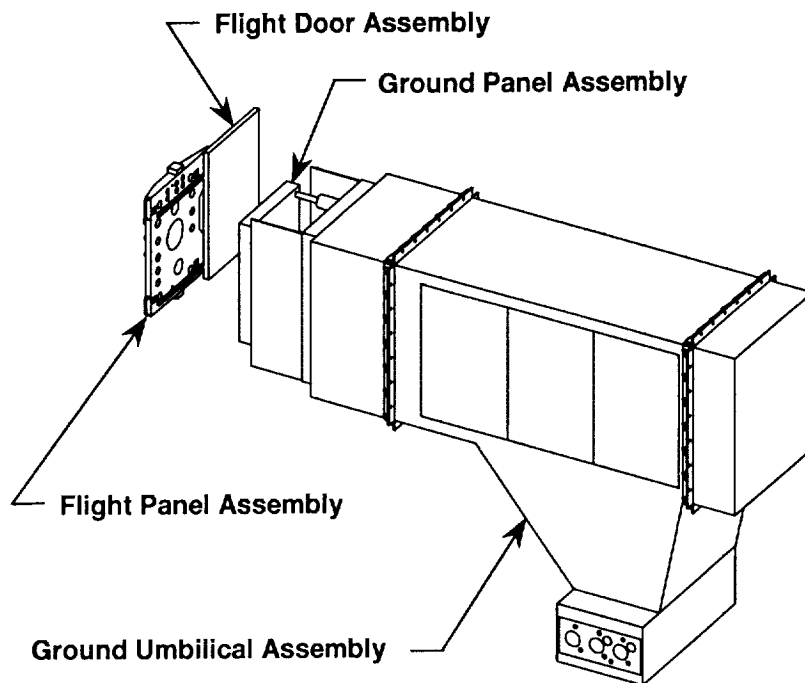

Figure 2. Ground and Flight Umbilical Assemblies

at proper operational levels, the vehicle initiates the pyrotechnic charges in the hold-down system to release the vehicle from the pad. The vehicle rises off of the pad with the umbilicals still connected. After rising 4 cm, release lanyards actuate the quick-release locks, and valves in the compliance mechanism open to actuate the latches supporting the translating frame. Next, the translating frame drops 110 cm into the tunnel as the compliance mechanism decelerates and centers the ground panel, hoses, and cables. Shock absorbers then decelerate the translating frame at the bottom of the tunnel. Finally, blast doors on the tunnel close to protect the ground panel assembly and mechanisms.

### **Passive Compliance Mechanism**

The key to the operation of the umbilical system is the self-centering, counterbalanced, six degree-of-freedom passive compliance mechanism that supports the ground panel assembly with hoses and cables during horizontal and vertical operation (Figure 3). The compliance mechanism must support the ground panel and adjust for misalignment during mating. It also provides the axial force required to mate the connectors. Finally, it must decelerate, center, and support the ground panel, hoses, and cables during the high-speed disconnect. The passive compliance mechanism uses a variety of specially-designed and commercial off-the-shelf components to accomplish these tasks.

#### Passive Compliance Mechanism Requirements

Some of the significant design requirements for the passive compliance mechanism were:

- Provide six degree-of-freedom capability
- Support the 800 kg panel assembly in horizontal and vertical modes
- Provide positive centering to nominal position
- Limit lateral centering forces to 1 kN transferred to vehicle while aligning
- Generate nominal axial centering force of 11 kN to assist mating
- Provide latch actuation via integral valves
- Maximize access to center of panel (support at perimeter)
- Provide lateral compliance +/- 3 cm
- Provide Axial compliance +16 cm, -4 cm
- Provide angular compliance within limits of lateral and axial compliance

#### Passive Compliance Mechanism Description

The compliance mechanism uses a simple arrangement of eight spring-centered struts to maintain the ground panel in the proper position for mating while allowing for misalignment and vehicle motions during mating, engine buildup, and launch.

The four axial strut assemblies (Figure 4) were designed specifically for the X-33 umbilical. A large (9 cm diameter) compression spring is used to generate the design preload of 2.75 kN on the strut piston to resist strut compression. The spring rate was minimized in order to provide a relatively constant force throughout the 16 cm compression stroke. This resulted in a significant initial compression of 19 cm required for assembly. (The stored energy in the spring created a significant risk to technicians if proper assembly or disassembly steps were not followed. The engineering team took great care to ensure that the hardware and procedures contained adequate safety warnings.) The second spring, nested within the first for space savings, resists strut extension by reacting between the strut rod and the piston. This configuration provides a self-centering strut with different strokes, preloads, and spring rates for each operating direction. Spherical rod ends allow for end rotation and strut length adjustment. An elastomeric stop is provided for the compression stroke in the unlikely event that the maximum strut compression occurs simultaneously with the translating frame maximum deceleration. Air transfer ports in the piston provide a limited degree of cushioning and damping. No additional damping was added to the system. The strut piston, in addition to providing the centering function, actuates an integral pneumatic control valve for the retract latches (discussed later).

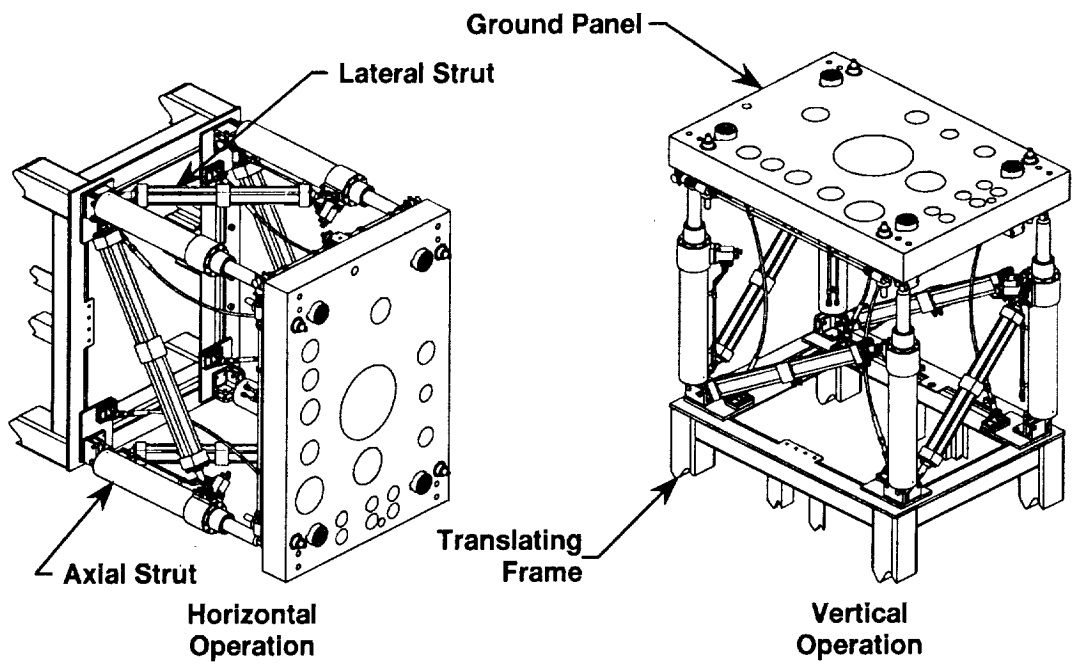

Figure 3. Umbilical Compliance Mechanism

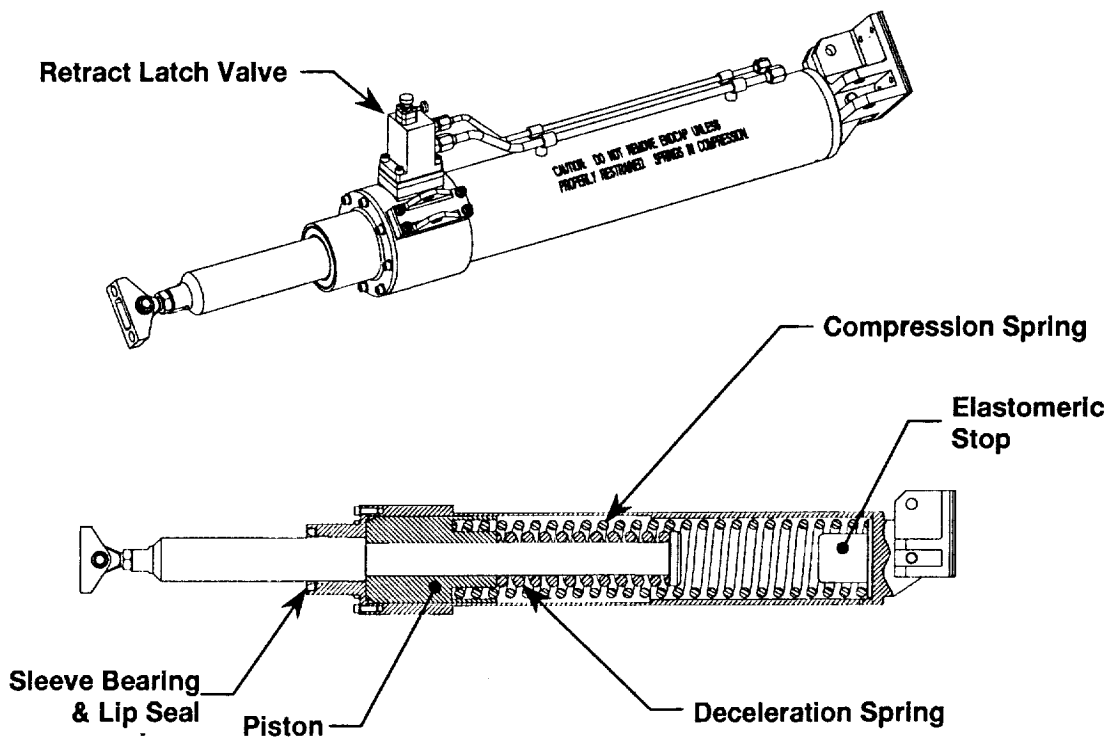
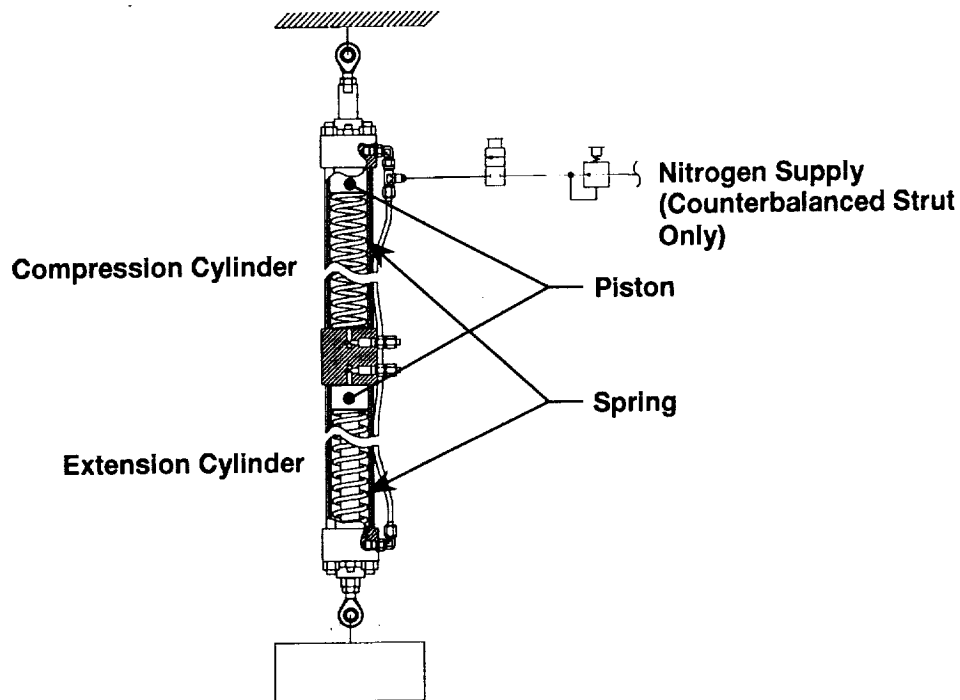

Figure 4. Compliance Mechanism Axial Strut Assembly

The four lateral strut assemblies center the ground panel with respect to the translating frame. One pair of struts provides spring centering only; the other pair of struts provides spring centering for vertical operation and has additional pneumatic counterbalance capability to support the ground panel, hoses, and cables for horizontal operation. The design of the lateral strut uses a back-to-back pair of commercial high-pressure pneumatic cylinders (Figure 5). One cylinder of each pair is spring retracted (extension cylinder) and the second is spring extended (compression cylinder). Together, they provide the spring centering capability required for the struts. Spherical rod ends allow for end rotation and strut length adjustment. Internal seal friction, airflow through the vent ports, and integral cushions provide a limited degree of damping. The counterbalancing capability is created by applying equal pneumatic pressure to the rod ends of both cylinders. The counterbalancing capability is created by applying equal pneumatic pressure to the rod ends of both cylinders. At the proper pressure setting, the struts support the weight of the panel while the springs provide the bias force necessary to overcome seal friction and center the strut. The pressure is removed from the struts after the vehicle is rotated to vertical. It should be noted that the strut system is "over-constrained;" that is, only three of the lateral strut assemblies are required for stability. The fourth strut assembly was added to eliminate moments induced into the panel assembly by lateral accelerations and prevent unwanted rotation of the plate following disconnect.



**Figure 5. Compliance Mechanism Lateral Strut Assembly**

**Panel Alignment Mechanism**

The panel alignment mechanism guides the ground panel into alignment with the flight panel for mating. After aligning the panels, the mechanism mates all of the umbilical connectors by guiding the panels together while maintaining alignment and parallelism. The alignment mechanism consists of a retractable pin system on the ground panel and mating receptacles on the flight panel.

### Panel Alignment Mechanism Requirements

Some of the significant design requirements for the panel alignment mechanism were:

- Correct for six degree-of-freedom initial misalignment of panels
- Eliminate possibility of binding during alignment or disconnect
- Align panels within +/- .015 mm
- Maintain panels parallel within +/- .03 mm throughout mating operation
- Operate with cordless drill or manually
- Provide nominal lateral alignment force of 1 kN, fail safe at 8 kN
- Provide maximum axial load capacity of 18 kN
- Accommodate maximum initial lateral misalignment of 2 cm
- Accommodate initial angular misalignment within limits of lateral misalignment
- Provide mating stroke (parallel motion) of 5 cm

### Panel Alignment Mechanism Description

The alignment mechanism uses four retractable tapered pins located at the corners of the ground panel. Four mating receptacles are located at the corners of the flight panel. The tapered pins and receptacles, in conjunction with the compliance mechanism, align the panels to the desired accuracy. After the panels are aligned, the four pins are retracted in unison to maintain parallelism as the connectors engage.

The tapered pin assemblies (Figure 6) are comprised of a housing, a commercial jack assembly, the tapered pin, and support bearings. The four pin assemblies are installed on the ground panel and linked with a system of shafts and gear drives for parallel operation (Figure 7). The tapered pin has a 10-degree half-angle cone and a flat end (Figure 8). The flat end prevents binding and accommodates thermal distortions and manufacturing tolerances (see next paragraph). The housing is aluminum, the bearings are plain bronze, and the pin is 15-5 PH stainless. The machine screw jack assembly is internally keyed to prevent screw rotation, the rated capacity is 4.5 kN and the lead is .127 mm / turn.

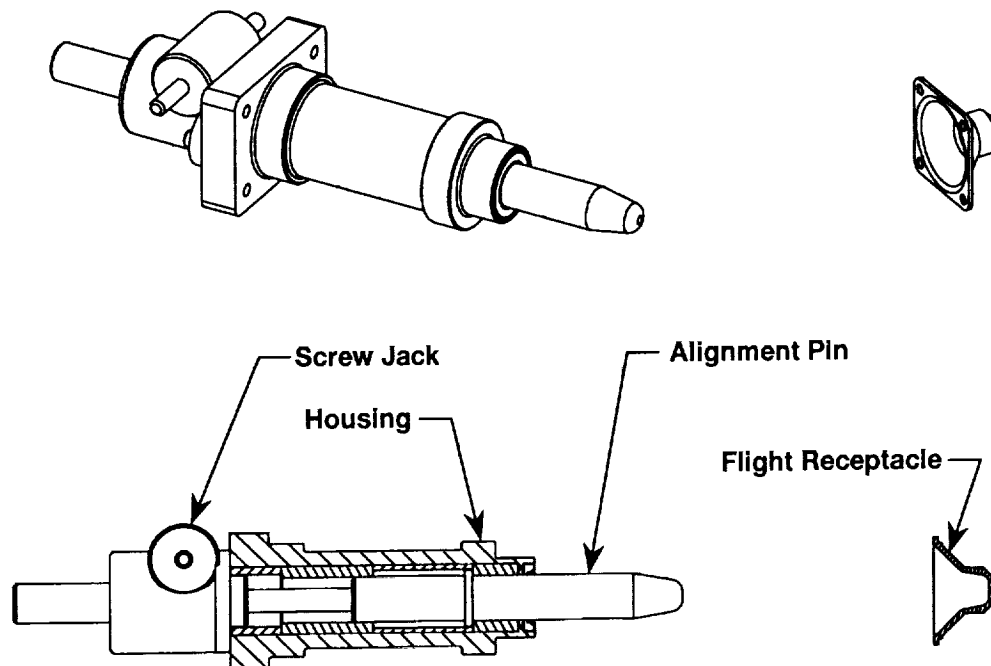

Figure 6. Alignment Pin and Receptacle

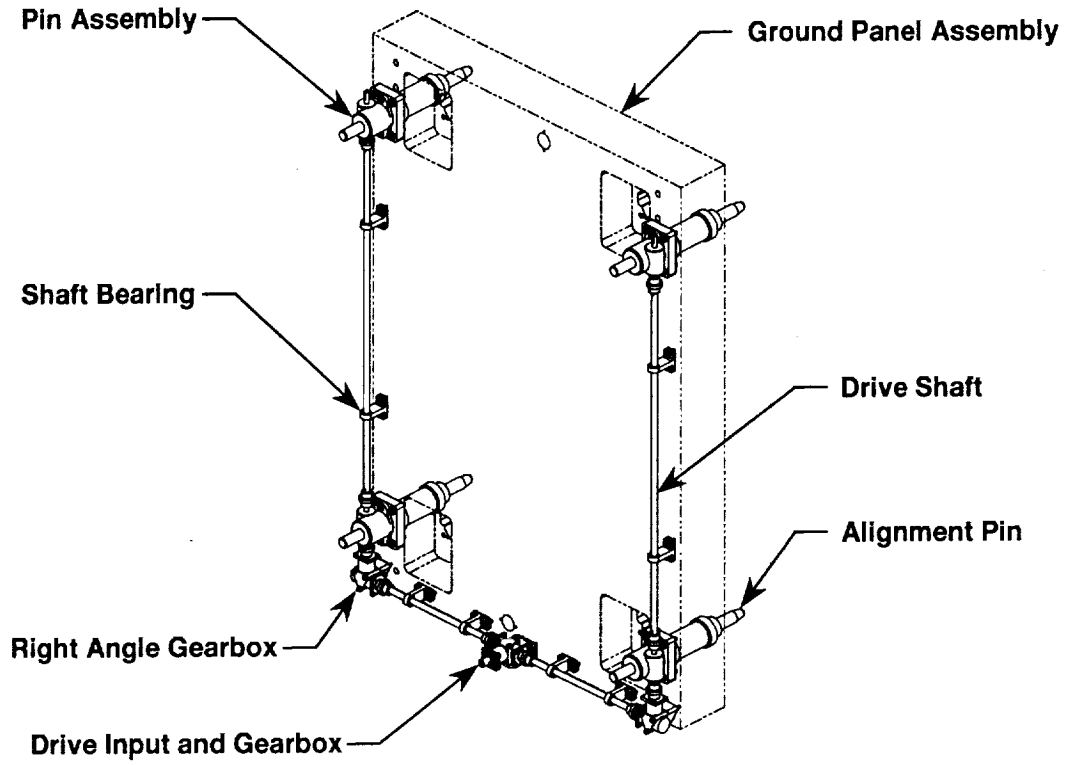

Figure 7. Alignment pin Assembly

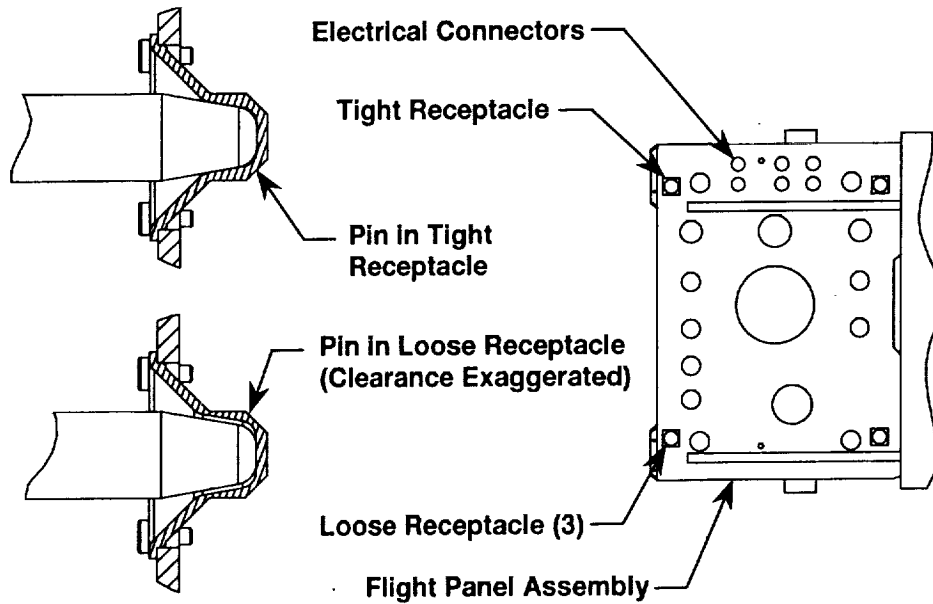

Figure 8. Alignment Pin Receptacle Details



The flight panel receptacles (Figure 6) are machined from A286 stainless. The pin and receptacle materials combination was selected to minimize the possibility of galling as the pin was guided into the receptacle. The internal geometry of the receptacle consists of an outer 45-degree half-angle cone and an inner 10-degree half-angle cone with a flat bottom. The inner cone matches the pin, the larger angle outer cone accommodates greater initial misalignment with less total insertion length. The use of two different flat-bottomed receptacles and the flat ended pins prevents binding or locking of the pins and accommodates thermal distortions and manufacturing tolerances. Plate-to-plate alignment was most critical for the electrical connectors. To reduce the alignment error at the electrical connectors, the inner cone of the receptacle nearest the connectors was toleranced to become tight simultaneously with the flat of the pin bottoming in the receptacle. The inner cone of the other three receptacles was toleranced to allow a slight radial clearance with the pins bottomed in the receptacles (Figures 8). This small radial float (.127 mm) accommodates the expected panel-to-panel variations, yet allows only a slight relative rotation between the panels. The geometry of the alignment system locates the critical electrical connectors within .04 mm when the plates are in thermal equilibrium.

### **Retract Latch Mechanism**

The umbilical retract mechanism supports the ground umbilical panel, compliance mechanism, translating frame, hoses, and cables in the extended position. Following liftoff, the latch mechanism is released, allowing the translating frame and the rest of the umbilical to free-fall into the umbilical tunnel. The latch mechanism must be fast acting and reliable for both remaining latched and unlatching on command.

#### Retract Latch Mechanism Requirements

Some of the significant design requirements for the panel alignment mechanism were:

- Provide load capacity when latched of 18 kN
- Unlatch in less than 250 ms from vehicle first motion
- Tolerate a single failure for latch and unlatch
- Latch automatically on frame extension
- Use stored energy for actuation

#### Retract Latch Mechanism Description

The retract latch mechanism uses four spring-extend, pneumatic retract latch assemblies arranged in mating pairs. One half of each pair is mounted to the translating frame. The other half of each pair is mounted to the umbilical tunnel (Figure 9). Each latch assembly is actuated by a dedicated control valve located on one of the axial struts of the compliance mechanism. The latch valves are supplied from a gaseous nitrogen accumulator charged to 17 MPa. The latch arrangement shown is single failure tolerant for supporting the load and also for ensuring release. Since any latch pair will support the entire load, the inadvertent release of any single latch will not allow the translating frame to drop. Similarly, only one latch of each pair must release in order to allow the translating frame to drop. The 250 ms maximum operating time is somewhat misleading. Due to the fact that the vehicle may lift off from any point over a 8 cm range, the latch valve may not be actuated until the vehicle has risen over 8 cm. This results in an available operating time of only 150 ms. Analysis showed that, with proper pneumatic flow capacities, the 150 ms target was achievable.

The latch assembly (Figure 10) is comprised of a structural steel housing, steel latch, bronze pivot bearings, and a specially designed pneumatic cylinder. The latch profile is circular to prevent lifting of the assembly during unlatching. The spring return pneumatic cylinder (5 cm bore, 8 cm stroke) was designed with oversize ports for high speed operation. In order to obtain the desired latch speed (30 ms stroke time) the cylinder working pressure was approximately three times the pressure required to operate the latch statically. This, combined with the fact that load is zero at the end of stroke and some latches operate with no resisting force, created the need for significant cushioning in the cylinder. Both

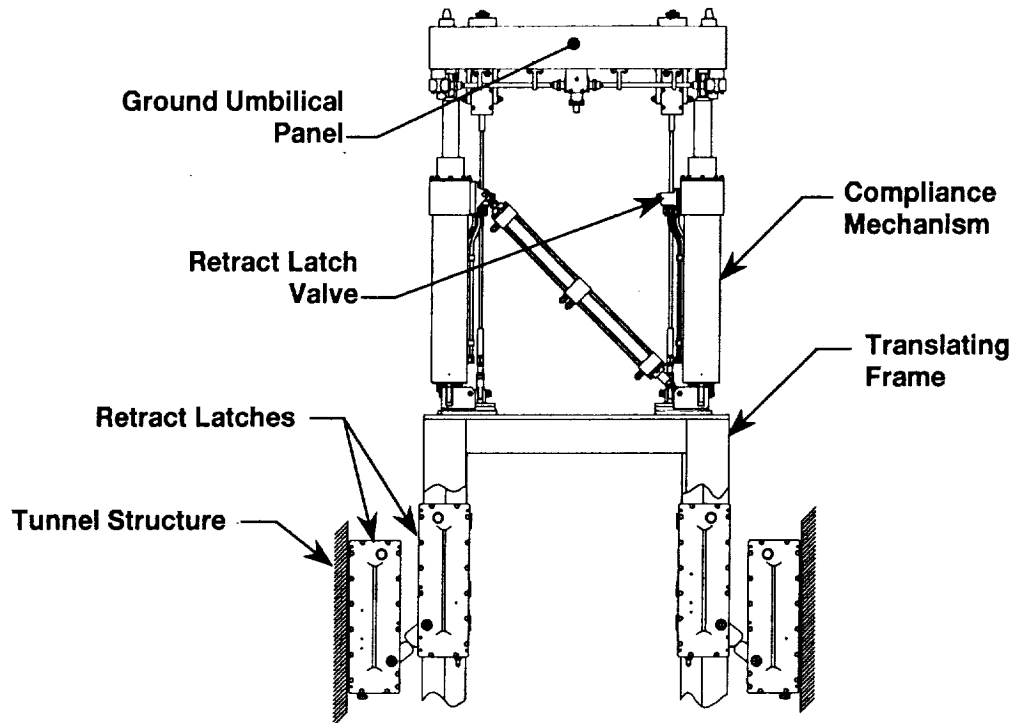

Figure 9. Retract Latch Mechanism Installation

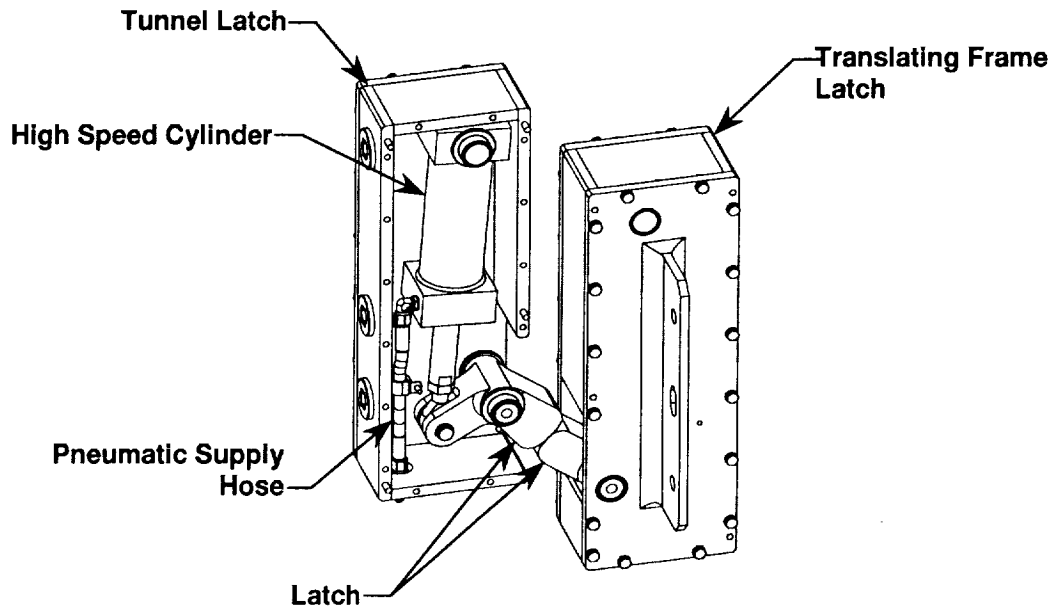

Figure 10. Retract Latch Mechanism

pneumatic and elastomeric cushioning were included in the design. Space constraints dictated that for each latch pair, one cylinder would extend to operate, the other would retract. Otherwise, all four latches are identical.

The latch valves (located on the axial struts) are direct-acting and sense vehicle liftoff from the axial strut piston. Each valve is dedicated to a latch assembly in order to prevent a valve failure from causing a premature disconnect of the umbilical or a failure of the umbilical to retract into the tunnel following liftoff. The valve-to-latch connections were arranged to minimize actuating time in the event that the vehicle pitches or yaws significantly during liftoff. As mentioned previously, 30 ms operating time was allotted to the latch itself for operation. The remaining 120 ms delay arises from valve actuation and pneumatic system "fill" time. The system drivers were the latches located on the umbilical tunnel. The latches on the translating frame are located within 1.5 m of the valves. The line lengths to the tunnel latches were nearly 10 m and accounted for most of the total delay. When operating normally, the latches on the translating frame will actuate well before the tunnel latches, resulting in faster system operation.

### **Quick-Release Lock Mechanisms**

The quick-release lock mechanisms resist the separation forces between the umbilical panels generated by fluid pressures and vibration. The mechanisms remain locked until they are released by lanyards following liftoff. The quick-release lock system consists of four collet locks located at the corners of the ground panel and four mating receptacles on the flight panel.

#### Quick-Release Lock Mechanisms Requirements

Some of the significant design requirements for the quick release lock mechanisms were:

- Resist panel separation force 71 kN (17.75 kN per lock)
- Support axial load only, shear forces resisted by shear pins
- Provide automatic locking and preload generation
- Provide single failure tolerance for release
- Minimize loads transferred to vehicle
- Prevent ice formation in mechanism

#### Quick-Release Lock Mechanisms Description

The quick-release lock mechanisms use a pin-expanded collet on the ground panel to engage a conical receptacle on the flight panel. A disconnect lanyard, connected to the translating frame, pulls the pin to release the lock. If the collet does not release, a cam mechanism on the ground mechanism shears the flight receptacle from its mount to release the panels.

An assembly view and details of the ground mechanism (collet lock) are shown in Figure 11. An aluminum housing interfaces with the ground panel through a bolted flange connection. The expanding collet is fabricated from beryllium copper. Threads in the housing and on the exterior of the collet allow for adjustment of joint preload by rotating the collet either prior to or after locking. The 15-5 PH stainless expansion pin has an integrally machined piston to allow the collet to be locked pneumatically. A key on the pin engages the collet. This key allows the collet to be rotated and locked from the exterior of the mechanism using the pin. The housing is bored for the piston seals and an aluminum end cap and rod seal close the cylinder. A bias spring in the cylinder maintains the collet in the locked position. A sliding aluminum sleeve is located on the front of the housing. The sleeve seats against the flight panel and resists the compression in the joint. Two roller assemblies are mounted to the back of the sleeve. An adjustable trunnion is attached to the expansion pin. Two A286 stainless steel release cams pivot on the trunnion and ride on the sleeve rollers. A lanyard bracket attached to the cams completes the mechanism. An ambient temperature helium purge through the joint prevents ice formation.

The flight receptacle (Figure 11) is comprised of an attachment bolt with a tapered head, a threaded housing with a tapered bore, a conical mating sleeve for interfacing with the collet, and a shear pin for

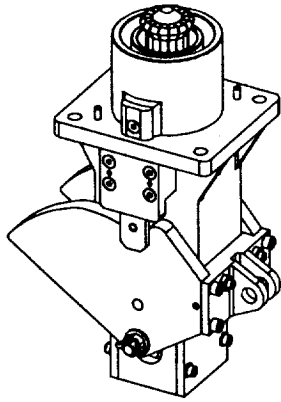

**Ground Lock Assembly**



**Flight Receptacle**

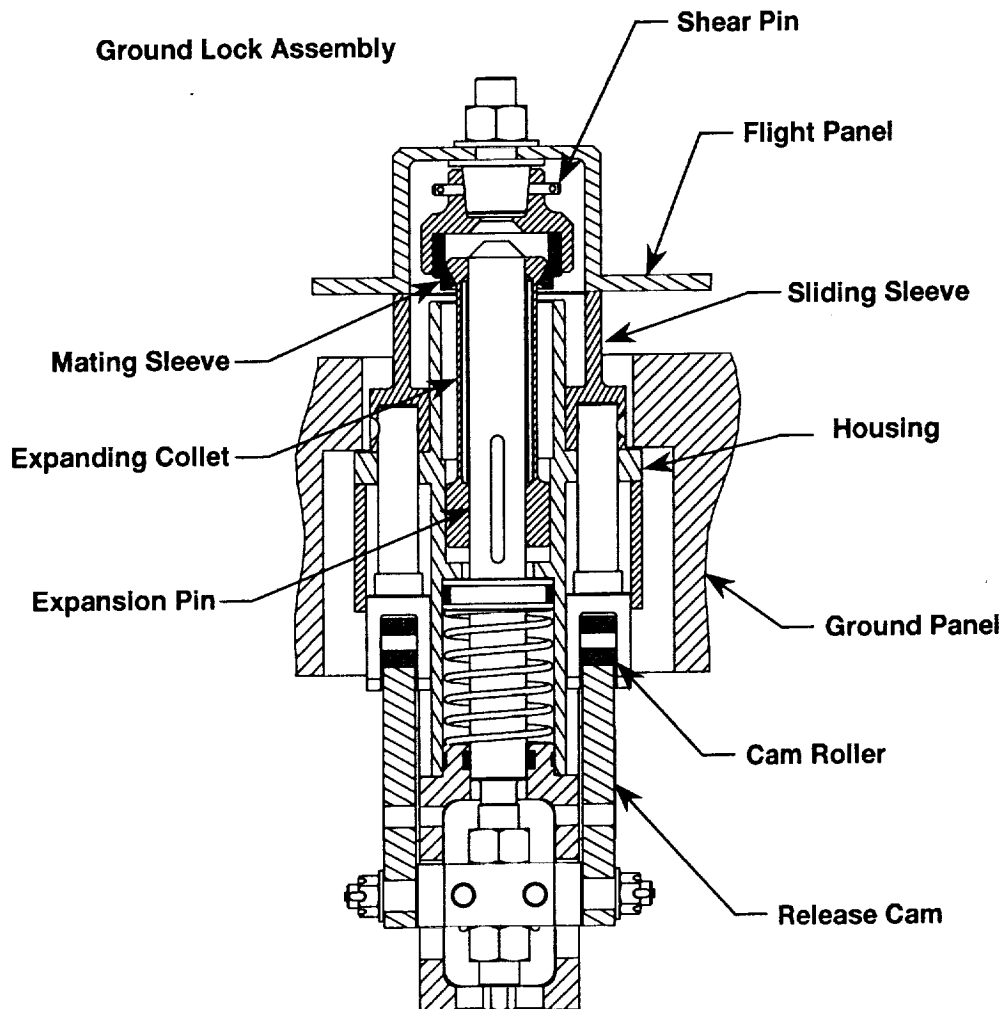
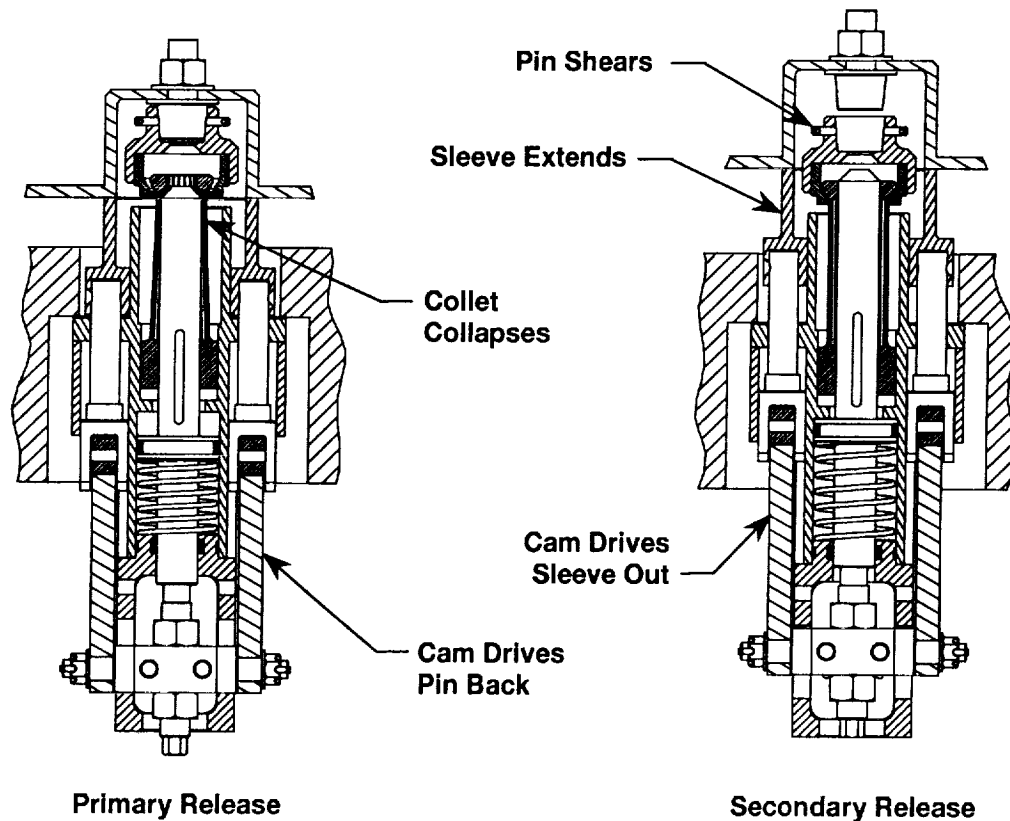

**Figure 11. Quick Release Lock Mechanism**

attaching the housing to the bolt for secondary release. All components, except for the shear pin, are fabricated from A286 stainless steel, and the conical sleeve is dry-film lubricated. The design shear-out load for the 17-7 PH stainless drawn wire pin is 24.5 kN (total in double shear), which is 150% of the design static load on the lock. The pin stock (all from a single lot) was ordered slightly oversize and pull tested to obtain a shear strength. The final pin diameter was determined from the shear tests. The flight pins, test pins, and spares were then ground to final size. Five pins were sheared for acceptance testing. All of the test pins sheared within 50 N of the design target. There was some concern about wedging the receptacle together and increasing the shear-out force. To eliminate this possibility, an assembly tool was used to control the axial force applied to the tapered connection during match drilling and pinning.

The lock mechanism is mated (locked) by inserting the collet into the conical sleeve until the sliding sleeve is firmly seated against the flight panel. Pneumatic pressure is applied to the cylinder to drive the pin into the collet and expand the fingers. The tapers in the sleeve and on the collet fingers generate the desired joint preload. Pin insertion pressure is used to verify proper preload generation. Figure 11 shows the mechanism in the locked configuration.

For a primary release of the mechanism, the lanyard pull causes the cams to rotate and react between the trunnion and the sleeve rollers to retract the pin and collapse the collet fingers (Figure 12). Additional pull on the lanyard drives the sleeve forward on the housing to provide a kick-off force for separation.



**Figure 12. Lock Mechanism Release Modes**

The lock mechanism can tolerate several different failures of the primary operation. If the cam bearings were to seize and prevent rotation, the pin will still be pulled (with a loss of the mechanical advantage of the cam) to release the joint. The kick-off force will not be applied in this case. In the event that the pin does not retract, the cams immediately force the sleeve forward to separate the joint by breaking the

shear pin in the flight receptacle (Figure 12). Note that the force to shear the pin is reacted internally in the lock and the only external force applied to the vehicle is the lanyard load. The system mechanical advantage reduces the lanyard load to approximately 33% of the shear-out load. Similarly, if the pin is retracted but ice or debris prevents the collet from collapsing, the sleeve will still shear the flight pin as noted above. Finally, if the entire mechanism or the lanyard were to fail, the weak link in the system is still the shear pin. This case would, however, transfer the entire shear-out force (24.5 kN) to the vehicle.

### Verification Testing

A verification test program was performed to demonstrate proper operation of the X-33 umbilicals in processing and launch modes. Testing was divided into two phases for each umbilical. The first phase tests were performed with the umbilical in the horizontal processing configuration. The second test phase was performed with the umbilical in the vertical launch configuration. Rotation testing was performed at the launch site.

The horizontal tests verified umbilical mating (connection), de-mating, and leak tightness. The counter-balanced struts in the compliance mechanism worked well. The ground panel was held centered but could be easily deflected by a technician. The return to center was somewhat sluggish. The seal friction on the piston and rod increased significantly when the cylinder was pressurized. A slightly higher force in the return springs would have helped eliminate this problem. Each umbilical was mated with nine different initial alignment offsets. The compliance mechanism and alignment system accurately mated the panels. The quick-release locks (collets) consistently generated the desired preload. With the exception of a seal that was damaged during shipping, there were no out-of-specification leaks detected. Figure 13 shows an umbilical during horizontal testing and gives a good idea of the size of the systems. The umbilical mate time was reduced to less than one hour from more than eight hours required for the Space Shuttle. Most of the time is used for cleaning, inspection, and verification. The actual mate process only takes a few minutes.

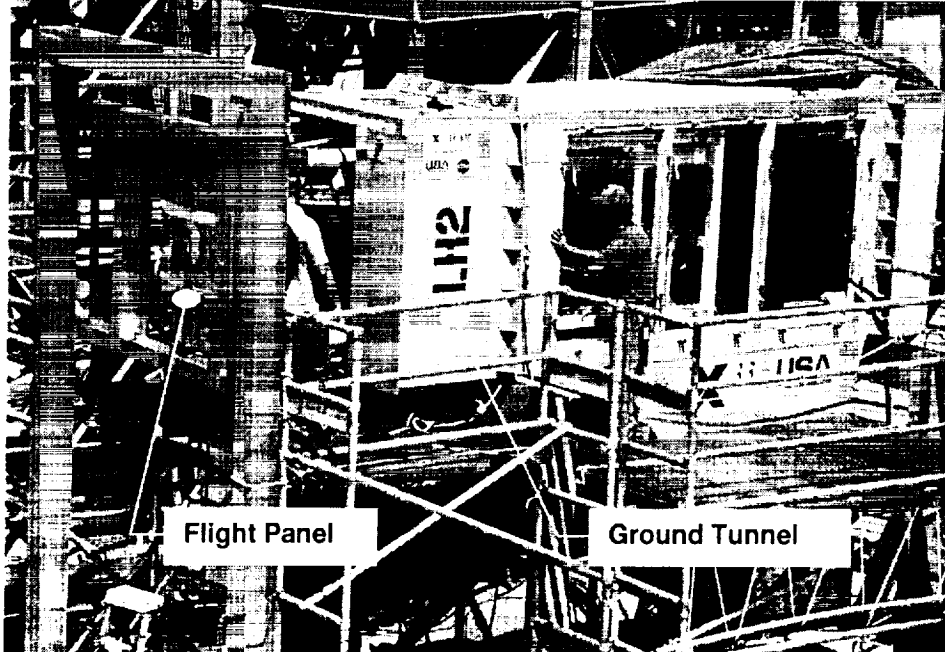

Figure 13. Horizontal Test Setup

Vertical testing of the umbilical verified proper leak tightness and launch disconnect dynamics. The umbilicals were mated and translated to a worst case misalignment for disconnect. Liquid nitrogen and liquid hydrogen (hydrogen umbilical only) were circulated through the appropriate connectors to simulate vehicle tanking. Liquid nitrogen was used instead of liquid oxygen to reduce the hazard while testing at a temperature slightly lower than required. Leak tests were performed in the cryogenic condition. Finally, the cryogenics were drained and a launch simulation was performed by raising the flight panel at the launch acceleration rate. All leaks were within specification. Minor frost developed in several areas of the panels but was not significant. Each panel was disconnected four times, one test for each umbilical involved disabling the lock expansion pin to force a secondary disconnect. All tests were successful.

The quick-release locks worked extremely well. All four locks typically disconnected within 5 ms of each other. Lanyard loads were as expected. Primary release dynamic loads were typically around 1.8 kN. The secondary release worked smoothly without damaging any components. The lanyard dynamic load for secondary release was 16 kN. The compliance mechanism smoothly centered and decelerated the ground panel and hoses. The system was under-damped (as expected) but this did not affect operation in any way. Total operation time for the umbilical was less than 1.1 seconds with all four latches operating. The translating frame latches released between 70 and 150 ms after first motion, depending on the vehicle starting position. Test data indicated that the failure of a translating frame latch would delay operation an additional 50 ms. The failure of a latch was not simulated during test. Figure 14 shows an overall view of an umbilical during vertical testing. Figure 15 shows a close-up view of the ground and flight panels mated for a vertical test.

### **Conclusions and Lessons Learned**

Although the entire program went relatively smoothly, there were several lessons learned that may prove useful to others. The most significant problem encountered during the program involved a simple purge seal located around the perimeter of the ground panel. The seal compression force was erroneously assumed to be minimal due to the soft material being used. The problem occurred because, although the seal was soft, its length was nearly 6 m. The seal was actually capable of generating several hundred Newtons of separation force and preventing the plates from fully mating under certain contingency conditions. Lubricating the seal allowed it to compress adequately for mating. Another problem encountered was that, due to the short schedule, the effects of late design changes were not thoroughly analyzed. A guide track for the flight door was added at the end of the design. This track was located too close to a quick-release lock and actually impacted the lock sliding sleeve during disconnect. No hardware changes were made as the impact occurred from a worst case disconnect position and damage was minimal. Leakage from one of the seals on the retract latches was noted during one of the tests. After about a minute, the leak stopped. The piston seal was apparently not seating properly when suddenly pressurized with nitrogen at 17 MPa. The latched still released properly, even with the leak. The cylinder was cycled several times, and the problem never recurred. As discussed previously, the friction in a dynamic fluid seal can vary considerably with pressure. Testing may be required to determine the actual seal friction under pressure.

The final lesson learned involved the test stand. It is imperative that the engineers understand the possible failure modes of the test equipment and how they might impact the test or the test hardware. There also needs to be good communication between the test technicians and the engineering team. Prior to one of the tests, a technician noticed a small leak on the hydraulic system for the lift-off simulator. He simply tightened a loose fitting and did not inform the test team. Toward the end of the next cryogenic test, as the liftoff simulator was being pressurized for disconnect, the air that had entered the system through the leaky fitting slowly compressed and allowed the umbilical to rise slightly and initiated an inadvertent disconnect. The data acquisition systems were not yet operating and all test data were lost.

In conclusion, the X-33 umbilicals were successfully tested and have been installed on the vehicle and at the launch site. The umbilicals utilize several new mechanisms to significantly reduce operational timelines.

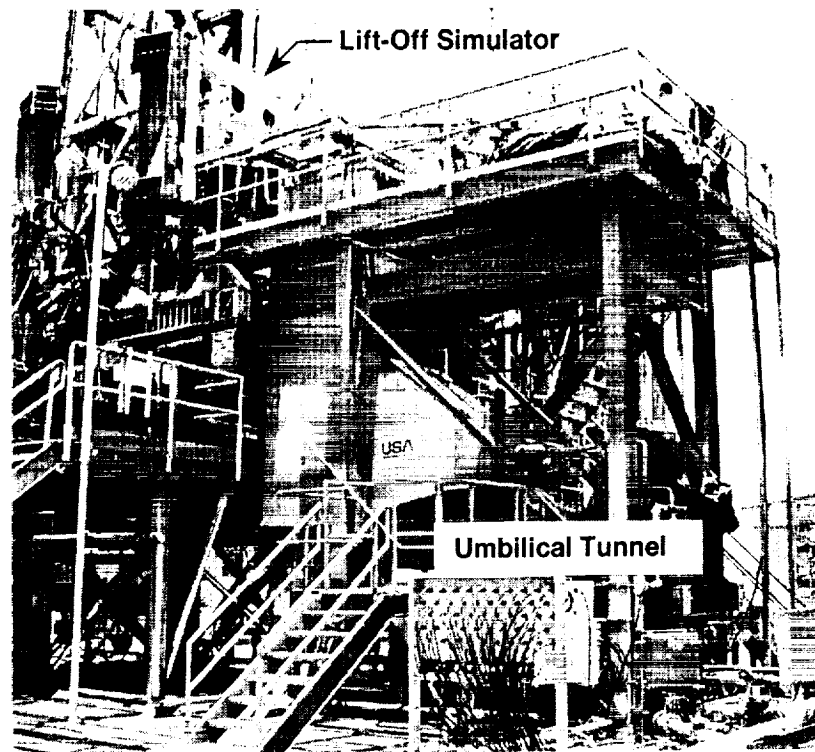

Figure 14. Vertical Test Setup

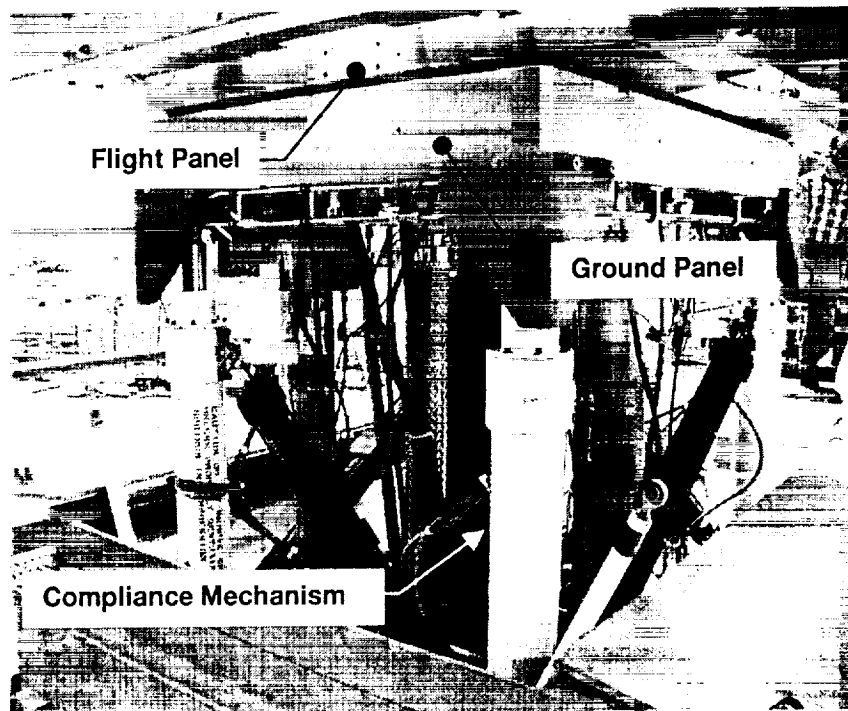

Figure 15. Detail of Vertical Mate