

NASA/SP-2000-6109/VOL2/REV1



International Space Station Evolution Data Book

Volume II. Evolution Concepts

Revision A

*Catherine A. Jorgensen, Editor
FDC/NYMA, Hampton, Virginia*

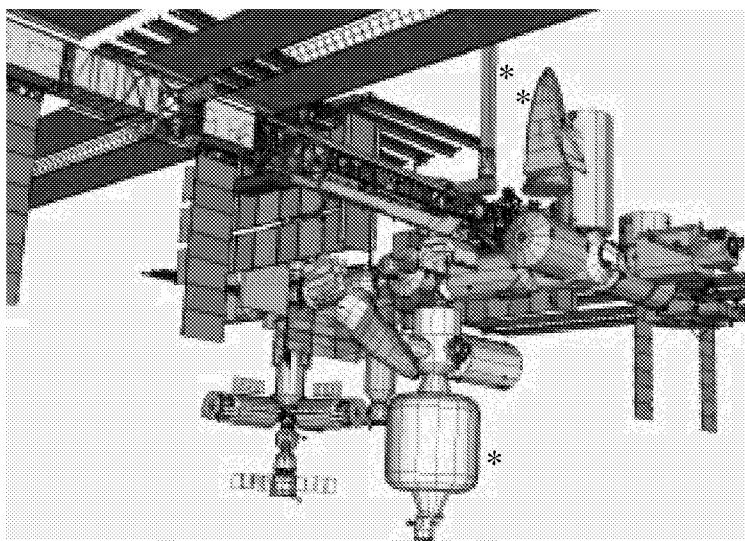

*Conceptual rendition of possible future evolution applications
and does not represent baseline design efforts.

October 2000

The NASA STI Program Office . . . in Profile

Since its founding, NASA has been dedicated to the advancement of aeronautics and space science. The NASA Scientific and Technical Information (STI) Program Office plays a key part in helping NASA maintain this important role.

The NASA STI Program Office is operated by Langley Research Center, the lead center for NASA's scientific and technical information. The NASA STI Program Office provides access to the NASA STI Database, the largest collection of aeronautical and space science STI in the world. The Program Office is also NASA's institutional mechanism for disseminating the results of its research and development activities. These results are published by NASA in the NASA STI Report Series, which includes the following report types:

- **TECHNICAL PUBLICATION.** Reports of completed research or a major significant phase of research that present the results of NASA programs and include extensive data or theoretical analysis. Includes compilations of significant scientific and technical data and information deemed to be of continuing reference value. NASA counterpart of peer-reviewed formal professional papers, but having less stringent limitations on manuscript length and extent of graphic presentations.
- **TECHNICAL MEMORANDUM.** Scientific and technical findings that are preliminary or of specialized interest, e.g., quick release reports, working papers, and bibliographies that contain minimal annotation. Does not contain extensive analysis.
- **CONTRACTOR REPORT.** Scientific and technical findings by NASA-sponsored contractors and grantees.
- **CONFERENCE PUBLICATION.** Collected papers from scientific and technical conferences, symposia, seminars, or other meetings sponsored or co-sponsored by NASA.
- **SPECIAL PUBLICATION.** Scientific, technical, or historical information from NASA programs, projects, and missions, often concerned with subjects having substantial public interest.
- **TECHNICAL TRANSLATION.** English-language translations of foreign scientific and technical material pertinent to NASA's mission.

Specialized services that complement the STI Program Office's diverse offerings include creating custom thesauri, building customized databases, organizing and publishing research results . . . even providing videos.

For more information about the NASA STI Program Office, see the following:

- Access the NASA STI Program Home Page at <http://www.sti.nasa.gov>
- Email your question via the Internet to help@sti.nasa.gov
- Fax your question to the NASA STI Help Desk at (301) 621-0134
- Telephone the NASA STI Help Desk at (301) 621-0390
- Write to:
NASA STI Help Desk
NASA Center for AeroSpace Information
7121 Standard Drive
Hanover, MD 21076-1320

NASA/SP-2000-6109/VOL2/REV1

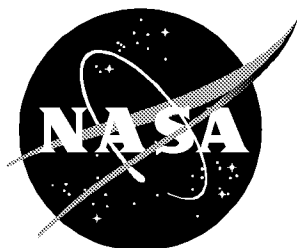

International Space Station Evolution Data Book

Volume II. Evolution Concepts

Revision A

*Catherine A. Jorgensen, Editor
FDC/NYMA, Hampton, Virginia*

National Aeronautics and
Space Administration

Langley Research Center
Hampton, Virginia 23681-2199

October 2000

Acknowledgments

The following personnel of the Spacecraft and Sensors Branch of the Aerospace Systems, Concepts and Analysis Competency of the Langley Research Center helped to compile and write various sections of the document:

Patrick A. Cosgrove: Electrical Power System, Thermal Control System, and Energy Enhancement
Jeffrey Antol: Structures and Mechanisms, Pressurized Payloads, Attached Payloads, and Free-Flyer Satellite Servicing
Frederick H. Stillwagen: Communications and Tracking and Advanced Communications Tower
Carlos M. Roithmayr: Guidance, Navigation, and Control and Tether for ISS Orbit Maintenance
John B. Hall, Jr.: Environmental Control and Life Support System
George G. Gano: Command and Data Handling
Gregory A. Hajos: Propulsion System and TransHab on ISS
Marianne Rudisill: Flight Crew Systems, Exploration DRM - Biotechnology
Melvin Ferebee: Exploration DRM
William Cirillo: Reusable Launch Vehicle DRM
Kathleen R. Gonzales (Langley Aerospace Research Summer Scholar): ISS Commercialization Activities

and from Boeing Engineering Services:

Rudy Saucillo: Reusable Launch Vehicle DRM

Special thanks are due to the Library and Media Services Branch of the Langley Research Center who published this document, with special acknowledgment to the NCI Technical Publications Support Group at Langley (Eloise Johnson and Mary Edwards who edited this document, Leanna Bullock who did the graphics, Martha Jones and Patricia Gottschall who typeset this document, and Cathy Everett who researched and formatted the references). Special thanks are also given to those members of the ISS Program Office at Lyndon B. Johnson Space Center and at other NASA centers who have provided information and assistance that was needed to compile and publish this document. This work was performed under contract NAS 1-96013 with Jeffrey Antol as Technical Monitor.

The use of trademarks or names of manufacturers in this report is for accurate reporting and does not constitute an official endorsement, either expressed or implied, of such products or manufacturers by the National Aeronautics and Space Administration.

Available from:

NASA Center for AeroSpace Information (CASI)
7121 Standard Drive
Hanover, MD 21076-1320
(301) 621-0390

National Technical Information Service (NTIS)
5285 Port Royal Road
Springfield, VA 22161-2171
(703) 605-6000

This report is also available in electronic form at URL <http://techreports.larc.nasa.gov/ltrs/>

1. Introduction

The International Space Station (ISS) will provide an Earth-orbiting facility that will accommodate engineering experiments as well as research in a microgravity environment for life and natural sciences. The ISS will distribute resource utilities and support permanent human habitation for conducting this research and experimentation in a safe and habitable environment. The objectives of the ISS program are to develop a world-class, international orbiting laboratory for conducting high-value scientific research for the benefit of humans; to provide access to the microgravity environment; to develop the ability to live and work in space for extended periods; and to provide a research test bed for developing advanced technology for human and robotic exploration of space.

The current design and development of the ISS has been achieved through the outstanding efforts of many talented engineers, designers, technicians, and support personnel who have dedicated their time and hard work to producing a state-of-the-art Space Station. Despite these efforts, the current design of the ISS has limitations that have resulted from cost and technology issues. An initiative is currently underway to look beyond the baseline design of the ISS and determine solutions to these limitations. The needs of the ISS are being assessed, prioritized, and worked to be resolved. The ISS must evolve during its operational lifetime to respond to changing user needs and long-term national and international goals.

As technologies develop and user needs change, the ISS will be modified to meet these demands. Volume II includes discussions which address the advanced technologies being investigated for use on the ISS and potential commercial utilization activities that are being examined. Included in this document are investigations of proposed design reference missions (DRM's) and the technologies being assessed by the Preplanned Program Improvement (P³I) Working Group. As these investigations progress and the ISS evolves, this document will be updated to keep all interested parties informed of the latest developments. Conceptual plans contained in this volume are not part of the baseline plans for the ISS and do not represent any officially sanctioned path for ISS Evolution.

This information is general and does not provide the relevant information necessary for detailed design efforts. This document is meant to educate readers about the ISS and to stimulate the generation of ideas for the enhancement and utilization of the ISS either by or for the government, academia, and commercial industry. This document will be kept as up-to-date as possible. Revisions to this document will be made as necessary to ensure that the most current information available is accessible to the users of this document.

The developers of this document welcome comments, questions, or concerns regarding the information contained herein. We are looking for input that will enhance sparse areas of the document with additional information, as well as suggestions for refining areas that may contain excessive information outside the scope of this document. Please direct any issues or suggestions regarding the ISS Evolution Data Book to

Jeff Antol
ISS Evolution Data Book Manager
M.S. 328
NASA Langley Research Center
Hampton, VA 23681-2199
Phone: (757) 864-5804
E-mail: j.antol@larc.nasa.gov

2. Advanced Technologies and Utilization Opportunities

2.1. P³I Technologies

The Preplanned Program Improvement (P³I) Technologies Working Group consists of technical experts from most of the NASA centers. The goals of the P³I program are to plan and implement ISS program improvements which substantially contribute to the following objectives:

- Enhanced research productivity and capability
- Increase reliability, maintainability, and sustainability
- Improve operational capability and reduce costs
- Synergistically support Agency strategic objectives

These objectives encompass the reduction of overall costs and ground infrastructure required to operate the ISS, enablement and support for the use of ISS as a technology test bed for Station capability enhancements and for general crosscutting technologies (i.e., for other NASA and government program support, commercial development, satellite or exploration probe system technologies), and the enablement and support of future human space utilization and development.

2.1.1. Program Activities and Process

ISS Chief Engineer's Office leads a team that reviews, identifies, and prioritizes P³I program content. The team has the responsibility to prioritize and make funding recommendations based on the following evaluation criteria:

1. Utilization capability and value enhancement
2. Significant systems performance improvement
3. Logistics (upmass and downmass) and on-orbit stowage reductions
4. Resource use and operating cost reductions
5. Leveraging from or with other ISS utilization or other program activities

The team meets semiannually to review content to support payload operations plan (POP) calls. Participation includes all human space flight centers and major programs as follows:

- ISS Chief Engineer's Office—Team Lead
- ISS Vehicle, Mission Integration, Operations, and Payloads Offices
- Johnson Space Center (JSC) Engineering Directorate, Technology Transfer, and Commercialization Offices
- JSC Exploration Office

- NASA Headquarters, Codes M, U, and S
- Other NASA Centers
- Department of Defense, Department of Energy, and other Government Organizations
- International Partners (IP) Representatives

The improvements presented are examples of the technologies which the P³I process has identified as having a high priority or which were previously selected through the Engineering Research and Technology Program. These examples are divided into two groups: near term and long term. The near-term examples are the technologies and projects that have been studied for feasibility, recommended to management for funding, but do not represent a funding commitment in the NASA budget process. The long-term examples are the technologies and projects that are being considered as possible improvements to the ISS but still need feasibility studies and further development. The long-term projects could be candidates for future design reference missions. (See section 5.)

2.1.1.1. Near-Term Examples

2.1.1.1.1. Enhanced Communications

The enhancement for the communications are described in the following sections.

2.1.1.1.1.1. Ku-band forward link. The Ku-band forward link will provide 3 additional years of required functionality from flights 6A through UF-5 for video teleconferencing and two-way computer file transfer to onboard operations local area network (OPS LAN).

2.1.1.1.1.2. Subsystems computer OPS LAN. An office support-type laptop will be connected to a centralized server via a wireless radio frequency (RF) LAN (no connection to the 1553 data bus). The laptop will include software such as word processing, E-mail package, graphics viewer, a manual procedure viewer (MPV), an onboard short-term plan (OSTP) viewer (time-line), World-map application. The hardware platform will be the same as the portable computer system (PCS) (IBM 760 laptop computer).

2.1.1.1.1.3. ISS communications ground systems upgrade. The ISS communications ground systems upgrade will add Ku-band uplink with command, voice, video, and file transfer capability. It will provide 150 Mbps downlink with four channels of compressed video, will increase the payload operations integration center (POIC) to support new uplink capabilities and compressed video, will upgrade links between White Sands Ground Station (WSGS), JSC, and Marshall Space Flight Center (MSFC) to support increased data rates, and will upgrade WSGS front-end (level 0 processing) migration to support increased Space Station data rates.

2.1.1.1.1.4. Phased array antenna. A phased array antenna (PAA) demonstration is planned for the Space Shuttle with implementation of this capability as part of the Shuttle upgrade planning. Installation on the ISS would have required significant modifications to the ISS for which funds were not available in the desired time frame. Interest still remains to find a way to install and begin testing PAA capability on the ISS.

2.1.1.1.5. Communications outage recorder. The communications outage recorder (COR) will provide 240 hr of payload data downlink coverage and will require the addition of a high rate data recorder which can be played back during tracking and data relay satellite system (TDRSS) access periods. Outage periods can be as long as 20 min with payload data downlink demands up to 40 Mbps during that period.

2.1.1.1.2. Flywheel Energy Storage System

The flywheel energy storage system is a solar-energy-driven motor that spins up during sunlit hours to between 50K and 100K rpm to generate current for subsystem power needs in darkness. Rotational momentum will also be used for attitude control. The sponsors for the flywheel energy storage system (FESS) project are the Glenn Research Center (GRC) and the United States Air Force (USAF) Research Laboratory.

2.1.1.1.3. Maintenance and Upgrades for Multiplexer/Demultiplexer 386 Processor

Study funding has been approved for replacement of the 386-based processor with a new processor based on concern for future growth of central processing unit (CPU) requirements and availability of parts. Flight hardware development funding will begin in 2001 with operational implementation in 2004, 2007, and 2012.

2.1.1.1.4. Ada Compiler Upgrade

Study funding has been approved for an Ada compiler upgrade. The current compiler runs on a VAX machine in a Honeywell-provided multiplexer/demultiplexer application test equipment (MATE) and is a retired product. A multistep upgrade plan for the compiler will increase the productivity of the programming staff including faster compilations (factor of 10), will remove conflicts due to multiuse of program MATE resources, and will evaluate changes in “object” code to understand reverification requirements for flight load.

2.1.1.1.5. Autonomous Extravehicular Activity Robotic Camera With Sensors for Leak Detection

The autonomous extravehicular activity (EVA) robotic camera (AERCam) with sensors for leak detection, a free-flying beach ball with cameras, was successfully demonstrated on STS-89 in January 1998. AERCam II is scheduled to be flight demonstrated in 2000. Development of sensors for leak detection and additional control for autonomous flight are ongoing, with flight experiment slated for flight UF-3 in 2003.

2.1.1.1.6. Metal Monolith Catalytic Converter

The metal monolith catalytic converter (MMCC) uses high cell density, short channel length metal monoliths, and specialized catalytic coating processes. It will extend the service life of the catalytic oxidizer orbital replacement unit (ORU) by at least 5 yr and the charcoal bed service life by 2 to 3 yr and will provide a 41-percent power savings. The MMCC system will provide a 98-percent reduction in recovering from a poisoning event.

2.1.1.1.7. Mass Storage Device Upgrade

A study is in process to determine the feasibility of replacing the mass storage device (MSD) with memory boards in the multiplexer-demultiplexer (MDM) because of reliability concerns with enhanced MDM mechanical disk MSD.

2.1.1.1.8. Sidewall Logistics Carrier

The sidewall logistics carrier is one option being investigated to alleviate oversubscription of attached payloads desiring a flight to the ISS and an installation location.

2.1.1.1.9. Battery Life Enhancements

Developments in advanced batteries are being studied. If the flywheel is successful, many of the batteries onboard the ISS may be replaced by the flywheels. However, a need to maintain some batteries to accommodate some contingency modes may still exist.

2.1.1.2. Long-Term Examples

2.1.1.2.1. Advanced Filters for Water and Air Processing

Advanced filters for water and air processing are aimed at reducing upmass and crew time required for filter changeout for the environmental control and life support system (ECLSS). These filters are targeted for operational implementation on ISS in the 2001–2002 time frame.

2.1.1.2.2. Phase III Communications Upgrade

A communications system needs to be developed to support expected data downlink demand up to 3 Mbps with short burst demands up to 1 Gbps. An antenna system could be provided by a commercial supplier, or NASA may lease services from one or more commercial suppliers for expanded data downlink needs.

2.1.1.2.3. Advanced Remote Power Controller Module

Reliability failure rate predictions indicate that the remote power controller module (RPCM), an ORU, is one of the drivers for maintenance upmass and crew time. This ORU is also part of the ISS systems upgrade focus of P³I, with study funding slated to begin in 2001 and operational implementation in 2010.

2.1.1.2.4. TransHab

TransHab is an inflatable module approach that will provide a means to launch a module in a stowed configuration and once deployed could expand the ISS volume substantially. It will also increase the space to provide additional opportunities for testing advanced life support and other technologies.

2.1.1.2.5. Hall Thruster for Orbit Maintenance

The Hall thruster is a solar electric propulsion system using the Hall current and its induced magnetic field to generate a thrust force. These devices have an extremely high specific impulse (1000 to 2000 sec) and very low thrust. This is one of the synergistic technology areas of the Human Exploration and Development of Space (HEDS) Program with a flight technology demonstration slated for 2003 and 2004. The sponsors of this effort are GRC and the USAF.

2.1.1.2.6. Stowage Enhancement Study

Options for soft stowage are being worked as part of the early assembly flight planning. Because the current lack of stowage is a potentially critical issue, recommendations for an overall stowage increase, specifically for payloads, are needed. Commercial options also need to be considered. No current funding is in place for a long-term study.

2.1.1.2.7. Logistics Efficiency Enhancement

In-house assessments of logistics improvement options, such as Shuttle/SPACEHAB/multipurpose logistics module (MPLM) enhancements, use of other autonomous transport vehicles, commercial offers, will be conducted. No current funding is in place for this study.

2.1.1.2.8. Ammonia Loop Pump Module Reliability Assessments

The current pump module has a failure rate of one failure every 2 yr. Failure causes the loss of 50 percent of the ISS power, and the ISS then becomes zero-failure tolerant for survival. Before proceeding with assessment and identification of options for resolution, funds have to be available.

2.1.1.3. Future Technologies

Numerous other technologies have been identified as resolutions to ISS needs. These technologies, although represented in the P³I road maps, are not all being investigated at this time. The P³I Working Group assesses and prioritizes the ISS needs and presents recommendations to NASA Headquarters for funding approval.

2.1.2. P³I Road Maps

Figures 2.1-1 to 2.1-6 represent schedules for technology improvement needs, which, in some cases, have synergistic links with improvements in the systems road maps and, in other cases, represent other improvements desired but not yet recommended or covered by other payload project funding. Each figure outlines the current P³I technologies that are on the table, and along the left-hand side of the figure are the subcomponents of each technology.

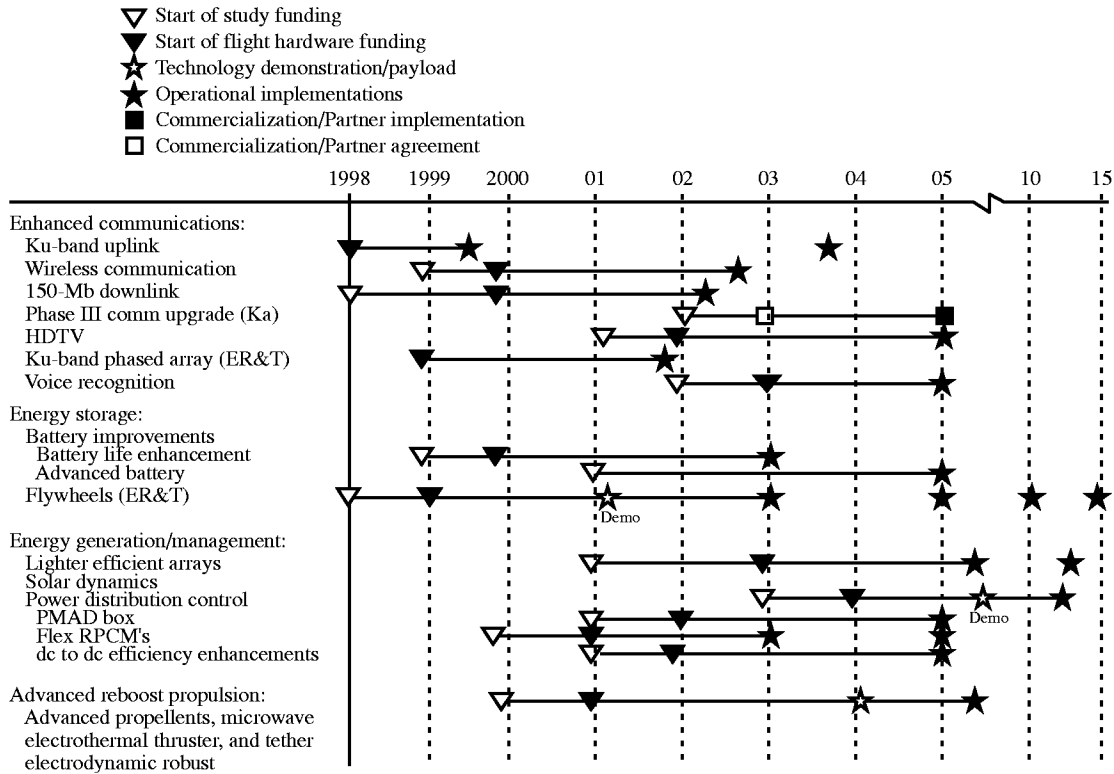

Figure 2.1-1. ISS systems, operations, and payload accommodations for schedule 1.

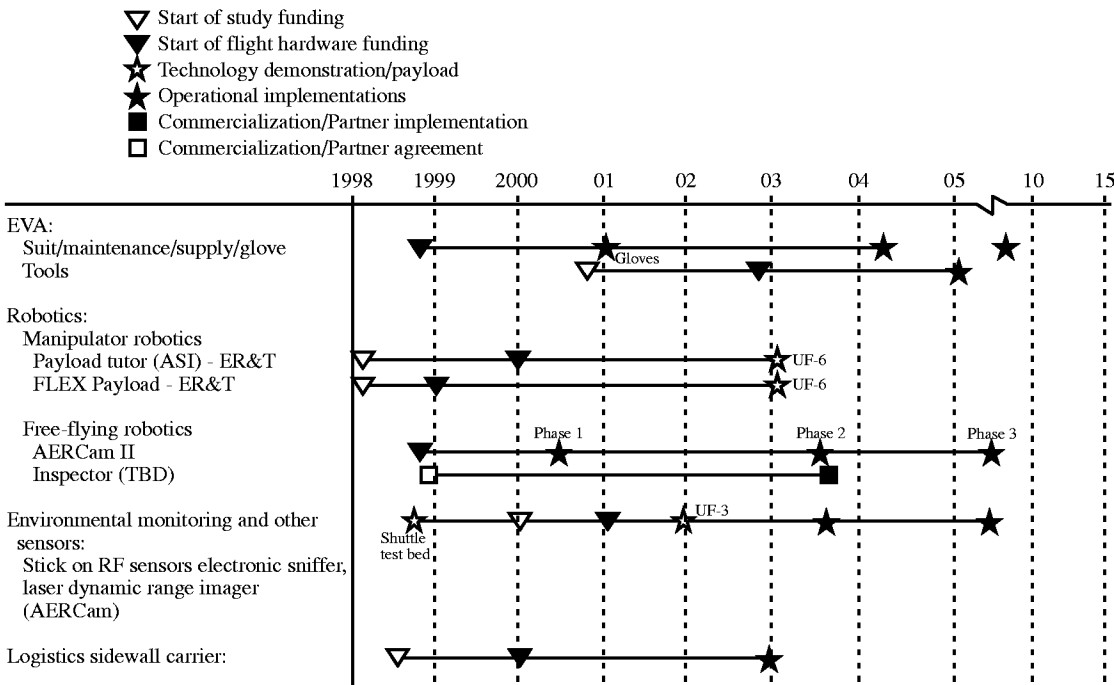

Figure 2.1-2. ISS systems, operations, and payload accommodations for schedule 2.

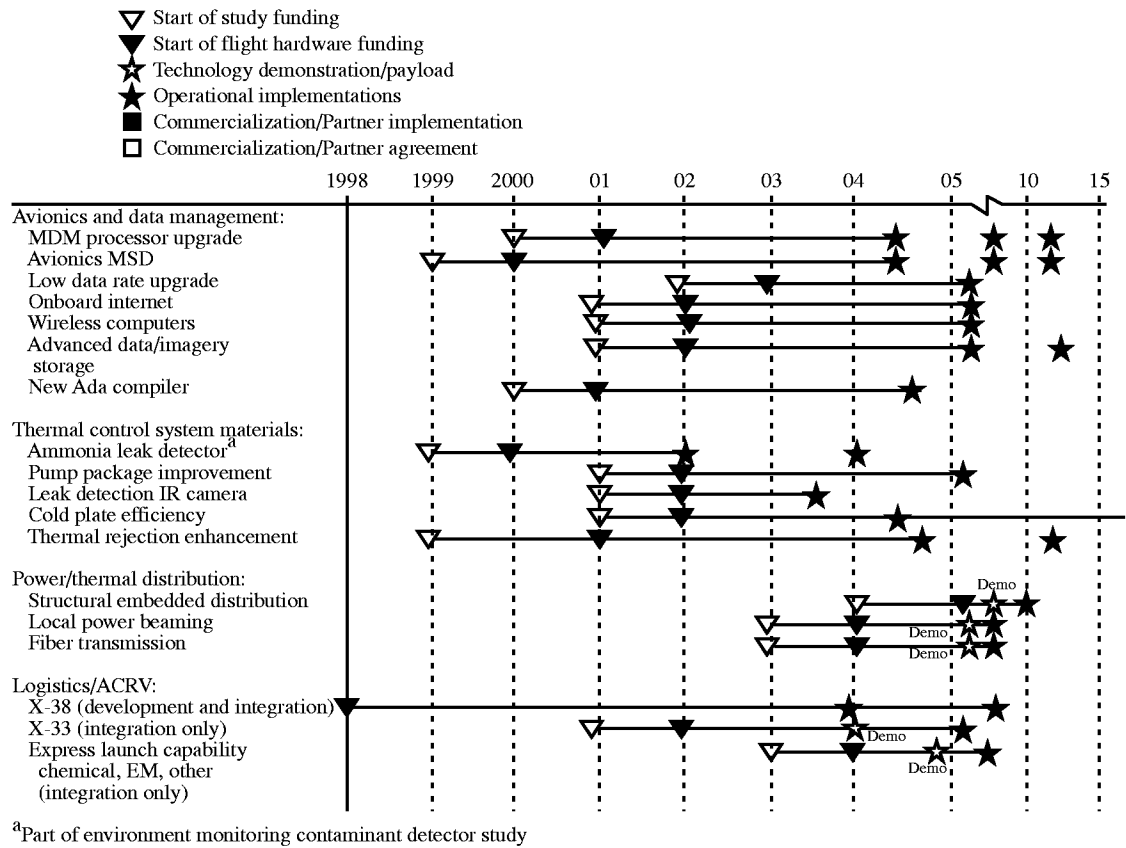

Figure 2.1-3. ISS systems, operations, and payload accommodations for schedule 3.

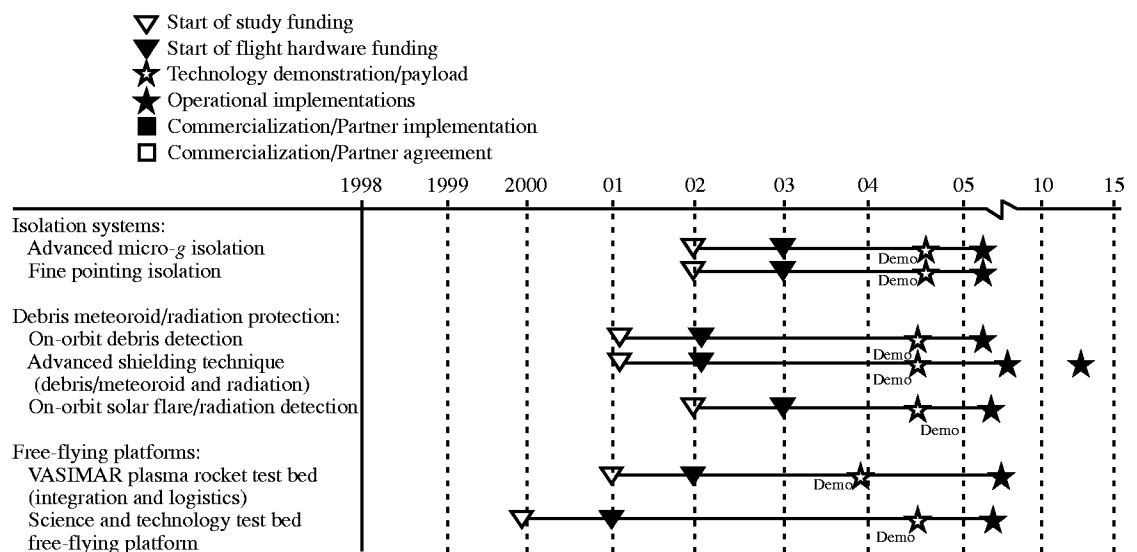

Figure 2.1-4. ISS systems, operations, and payload accommodations for schedule 4.

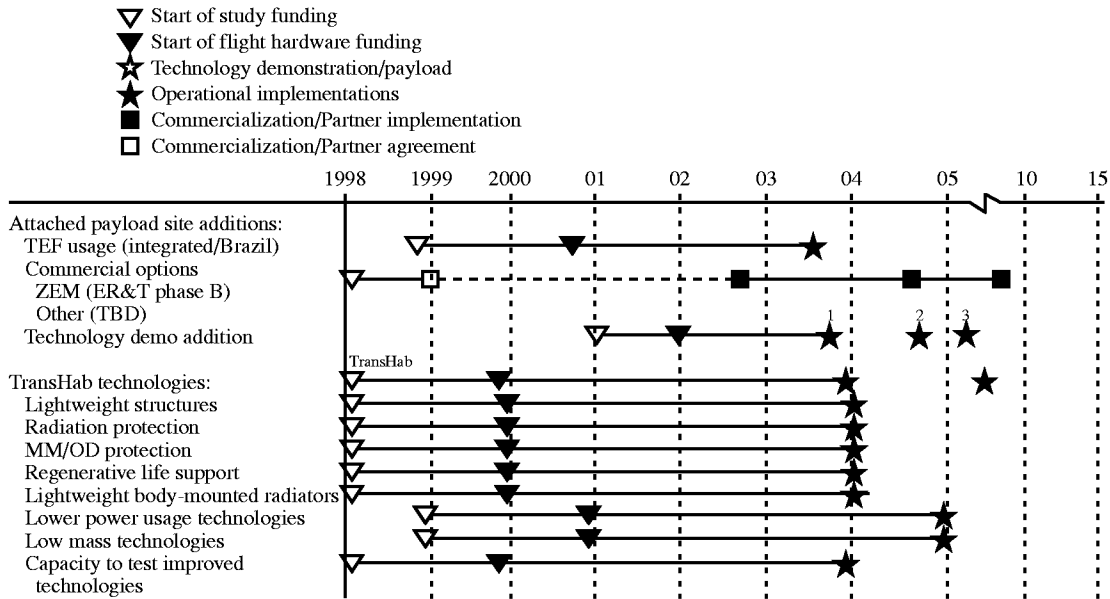

Figure 2.1-5. ISS systems, operations, and payload accommodations for schedule 5.

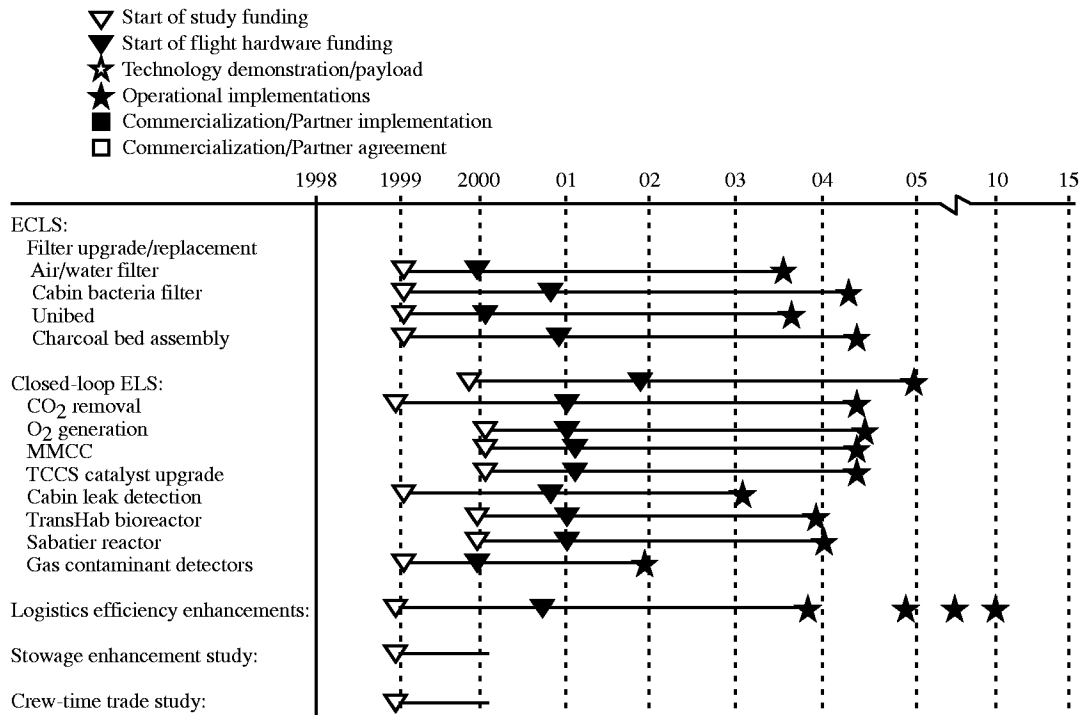

Figure 2.1-6. ISS systems, operations, and payload accommodations for schedule 6.

3. ISS Commercialization Activities

One of the primary goals of the ISS is to actively support commercialization opportunities to reduce the cost to develop and operate the ISS and to add or enhance its technical capability. The ISS program is addressing commercialization through two principal methods:

- Infrastructure
- Research and development

These methods are being pursued through two venues:

- Entrepreneurial offers
- Commercial Space Centers

Commercialization may be used to support ISS growth by enhancing either the research capability and/or the habitation capability of the ISS. These enhancements would provide additional resources and/or facilities to expand the current capabilities.

Potential commercialization opportunities for implementation in the short term (2000–2003) include communications, ground operations, imagery, and pharmaceuticals. Potential commercialization opportunities for implementation in the long term (2004–2006) include transportation and logistics. NASA is seeking entrepreneurial offers to accomplish these tasks and is developing a network of Commercial Space Centers in cooperation with universities to partner with industry.

NASA Headquarters and JSC currently are working towards the commercialization of the ISS. NASA Headquarters developed an ISS Commercial Development Plan and an Operational Work Instruction (OWI) defining the process of obtaining access to the ISS for entrepreneurial offers. Both these documents are described in this section. Additionally, this section includes potential opportunities for commercial utilization of the ISS in some of the ideas considered as viable markets.

3.1. ISS Commercial Development Plan

3.1.1. Overview

The ISS Commercial Development Plan is the initial step towards making a transition from the government-owned and operated Space Station to a commercially owned, operated, and utilized low Earth orbit facility. The plan outlines the incremental steps needed for an efficient and effective transition. The plan presents potential commercial ventures and encourages industry involvement in this transition. Commercial industry will have to actively participate in the development of the ISS to ensure the commercial needs of resources, facilities, crew time, and so forth, are understood by NASA and can be provided. Industry initiative is also encouraged to work with NASA to determine what enhancements to the ISS are necessary to meet industry needs and how those enhancements can be achieved.

The Commercial Development Plan outlines the short-term and long-term goals of this effort and the strategies and tactics to achieve these goals. The short-term goal of the Commercial Development Plan is to stimulate private investments to help offset a portion of the public cost of operating the Shuttle and the ISS. The long-term goal is to establish the ISS as a market place and to have a national economy that includes space products and services where both supply and demand are dominated by the private sector.

The strategy identified to achieve these goals involves developing a partnership with the private sector. NASA plans to establish pathfinder business opportunities that will achieve long-term, profitable operations without public subsidies. These businesses will then work to break down market barriers and pave the way for economic expansion. The potential candidates for these pathfinder businesses are shown in table 3.1-1. The evolution factors and rating criteria used for this study are shown in figure 3.1-1. Finally, the preliminary ratings are shown in table 3.1-2.

The candidates with high business potential, low risk, and medium barrier characteristics will be considered for the initial pathfinder set. The initial set of these pathfinder businesses includes

Table 3.1-1. Potential Commercial Opportunities

Users	Operations	New capability development
Pharmaceuticals Biotechnology Materials Electronics/photronics Communications Remote sensing Agriculture Imagery Education Entertainment Advertisement (e.g., PBS model) Space technology testbed Manufacturing	Training Ground processing Logistics, repair, and maintenance Transportation Crew and cargo Delivery/return On-orbit utilities (e.g., space-to-ground communications, maintenance engineering, design support to customers, problem resolution)	Augmentation: core resources Augmentation: new resources Additional modules and elements Free flyers Technology development

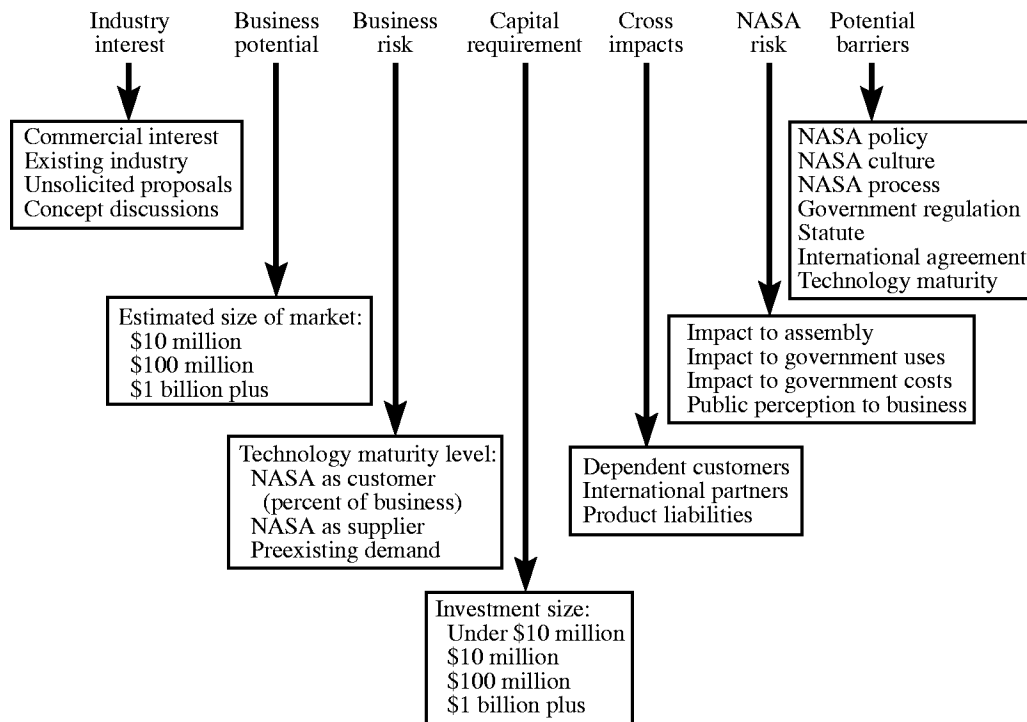

Figure 3.1-1. Preliminary rating chart.

users, operations, and new capability development. Under users, candidates include consumer goods in space, brand name public service sponsorships, educational products, payload accommodations, auctions, new product development (proprietary), and on-orbit research facility (proprietary). The operations pathfinder is in the area of imagery. The new capability development area is in communications and a ground operations facility (proprietary). NASA is currently evaluating several proprietary proposals, which will be pursued in parallel with other pathfinder cases. These proprietary cases are also allowing NASA to improve its process of handling incoming entrepreneurial proposals. The initial process for entrepreneurial proposals is outlined in section 3.2.

NASA commissioned an independent market assessment to determine the most effective pathfinder businesses. This effort involves universities, commercial space companies, and space business consultants to investigate areas including private market potential, use of Shuttle and Space Station as commercial platforms, commercially provided growth elements with Station as a customer, and the ISS becoming a fee-for-service laboratory or production center.

A second tactic is to identify barriers to market entry and to identify corrective actions to mitigate these barriers. The areas that have been addressed include access to space, the NASA administrative process for proposals, NASA policies in the pricing and cost of space transportation, public service sponsorships and endorsements, further enablement of commercial development, and intellectual property.

Table 3.1-2. Preliminary Ratings

C, NASA culture; G, government regulation; H, high; I, international agreement; L, low; M, medium; N, NASA policy; P, NASA process; S, statute; T, technology maturity level

Opportunity	Industry interest	Business potential	Business risk	Capital requirement	Cross impacts	NASA risk	Potential barrier	
							Risk	Reason
Aeronautics								
Space science								
Earth science								
Life/microgravity science								
Space flight systems								
Pharmaceuticals	H	H	M	M	L	L	L	P
Biotechnologies	M	M	L	M	L	L	L	P
Materials	M	M	L	M	M	L	L	P
Electronic/photonics	M	H	M	M	M	L	L	P
Nonelectronic	M	H	M	M	L	L	L	P
Communications	H	H	L	M	M	M	M	C
Remote sensing	M	M	L	M	M	L	M	T,G
Agriculture	M	M	L	M	L	L	M	T,G
Imagery	M	M	L	L	L	L	L-M	C
Education	M	M	M	L	L	L	L	C
Entertainment	H	H	M	M	M	L	M	N,C
Advertising	H	H	L	M	M	M	H	N,C
Space technology testbed	M	M	M	M	M	L	M	T,C
Manufacturing	L	M	H	H	M	M	H	P
Mission planning	L	L	M	L	L	L	L	C
Training	M	M	M	M	M	M	M	C
Flight control	M	M	M	M	M	M	M	C
Ground processing	M	M	L	M	M	M	L	
Logistics/repair and maintenance	M	M	M	M	M	M	M	C
Transportation	M	M	H	H	M	M	M	C,S,G
Crew/payload return vehicles	M	M	M	H	M	M	M	T,C
On-orbit resources	H	H	M	M	M	M	M	T,C
Maintenance engineering	L	L	L	L	M	M	M	C
Design support to customers	L	L	M	L	L	M	L	C
Problem resolution	L	L	M	L	M	M	M	C
Augmentation: core resources	M	H	M	L	L	L	L	T,I
Augmentation: new resources	H	H	H	M	M	M	M	T,I
Additional modules/elements	M	M	M	M	M	L	M	T
Free flyers	M	M	M	M	M	M	M	C,T

A third tactic being considered by NASA is to establish a nongovernment organization (NGO) for the utilization development and management of the ISS. This option for ISS management would have the NGO manage the utilization of the ISS while the government maintained control

of the ISS systems operations policy and oversight. The NGO would consist of a consortia of government, academia, and commercial industry and could be for-profit, nonprofit, or a hybrid consortium. The NGO could act as the interface or liaison between the users of the ISS that would be government, academia, and industry and the operators of the ISS, namely NASA and its contractors. Utilizing an NGO, NASA would hope to maximize the range of productive uses of the ISS and at the same time, minimize the high costs and lengthy schedules often associated with conducting user payload operations in space.

The NGO would work with the science community, the engineering community, and the space operations community to expand the scientific foundation and technological capability of the ISS for future human exploration and development of space. The NGO will also work together with the space community to achieve cheaper, better, and faster access to space for research and development (R&D) and commercial endeavors. Finally, the NGO will be responsible for disseminating the resulting information of any beneficial scientific or technological achievements to help stimulate commercial industry to expand the global economy in space products and services.

Ultimately, NASA plans to relinquish complete control over the ISS and turn all operations, utilization, and systems control over to a private organization, either for profit or nonprofit. NASA does not envision this happening until the ISS has been successfully operational for a minimum of 5 yr and a maximum of 10 yr. Additionally, the organization that will take over the operation of the ISS and all its facilities and resources must prove to NASA that it has the experience and financial capability to take on such an undertaking. Finally, the organization must clearly and continually show that it has the safety of the crew as its primary concern. Mr. Daniel Goldin, NASA Administrator, mentioned during the 8th Space Frontier Foundation Conference in Los Angeles, California, on September 23–26, 1999, that NASA cannot financially and operationally maintain the ISS for a period longer than 10 yr if they want to continue their explorative journey beyond Earth orbit.

3.1.2. Bibliography

Chran, Mark: Commercial Development Plan for the International Space Station. NASA, Nov. 16, 1998.

3.2. OWI for Registration and Disposition Process for ISS Entrepreneurial Offers

3.2.1. Overview

As commercial industries become more aware of the ISS, its capabilities and its needs, they will begin to determine whether they can utilize the environment for their benefit or whether they can provide technology upgrades to the ISS to enhance its capabilities. Generated ideas to use the ISS or to provide technology to the ISS will initially have to be reviewed and approved by NASA until an NGO or other form of proposal authority is chosen for the ISS. There are two avenues commercial industry can take for NASA to consider a proposal; each avenue handles a different type of proposal. Commercial industry can submit entrepreneurial offers, which are written offers for new or innovative ideas, involving ISS assets, submitted to NASA on the initiative of the offeror for the purpose of creating value-added products or services for sale primarily to the private sector, which is not in response to an RFP. The process for submitting this type of offer to NASA specifically to provide to the ISS or to utilize the ISS environment, resources, and/or space is outlined in this section and displayed in figure 3.2-1.

Industry can also offer NASA an unsolicited proposal, which is a written proposal for a new or innovative idea submitted to the agency on the initiative of the offeror or for the purpose of obtaining a contract with the government which is not in response to an RFP. The procedure for submitting this type of proposal is defined in the Federal Acquisitions Requirement (FAR).

All entrepreneurial offers should be mailed to

National Aeronautics and Space Administration
Human Exploration and Development Enterprise
U/M Director, Space Utilization and Product Development Division
Washington, D.C. 20546-0001

These offers will be received by the Division Director and will be logged for tracking purposes.

From there, the Commercial Development Manager (CDM) will classify the offer either as an unsolicited proposal or an entrepreneurial offer. If the offer is determined to be an unsolicited proposal, the submittal will be sent to the appropriate Office or Center for processing and a letter will be sent to the submitters for notification of status.

If the offer is deemed entrepreneurial, then it is evaluated further by the CDM for completeness of the technical and business elements; magnitude of private industry investment, predominance of a non-NASA market; cost, schedule, technical implications to NASA, and benefits to NASA and/or the general public.

If the offer does not meet the initial screening criteria, a letter indicating rejection and/or deficiencies will be sent to the offeror. If the offer meets the criteria, it continues through the process.

The next step is business, policy, and technical reviews, performed by the Commercial Evaluation Team. The business and policy reviews will be conducted at NASA Headquarters and the technical review will be conducted at the ISS Program Office at JSC. Questions to and responses from the offeror will be communicated to meet screening needs. At any time, if a response by the offeror is unsatisfactory, the offer may be rejected.

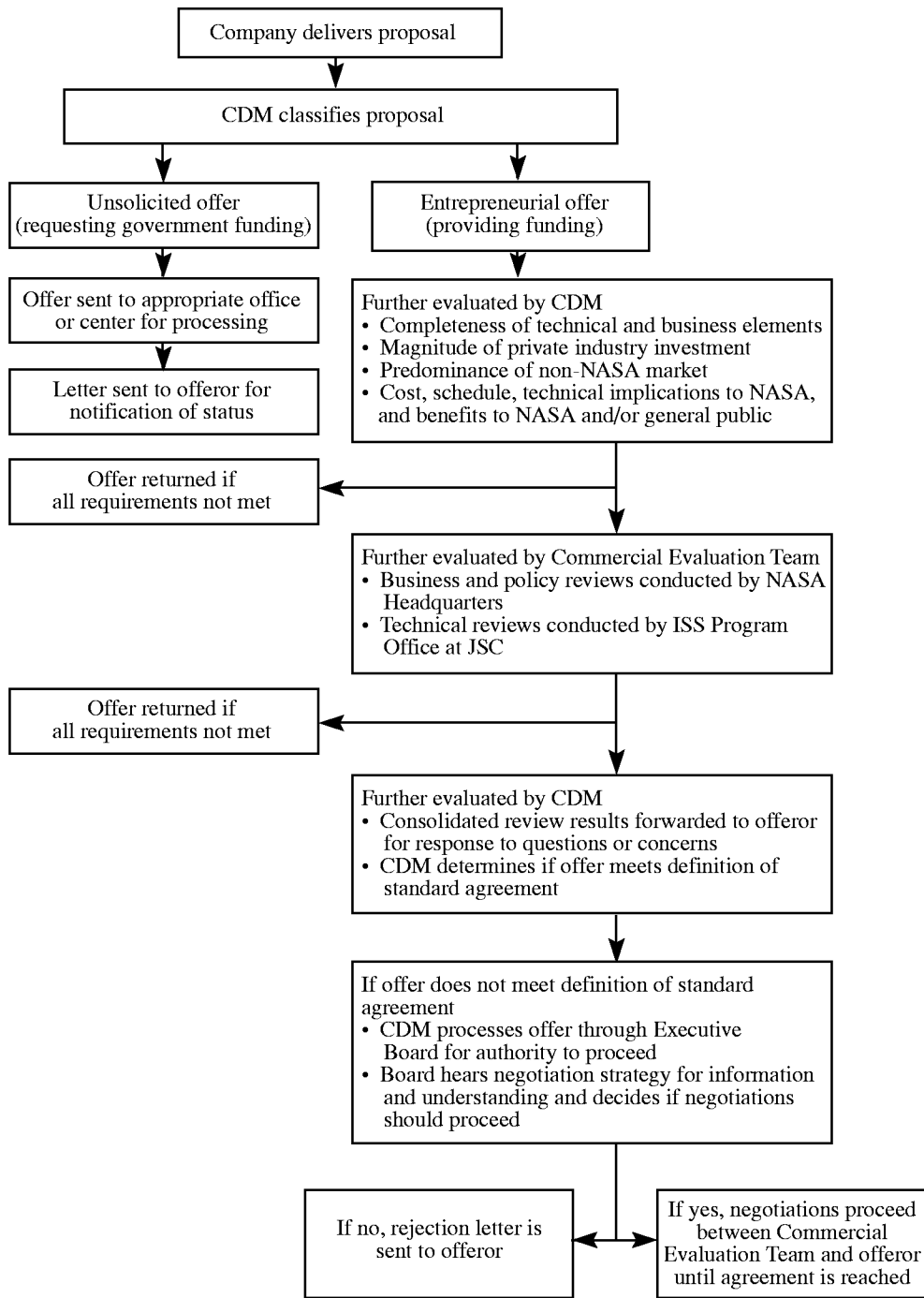

Figure 3.2-1. Overview of operational works instruction for registration and disposition for ISS entrepreneurial offers.

The CDM consolidates the review results into one source and forwards it to the offeror for the response to any questions or concerns. This process may be repeated as necessary.

The CDM determines whether the offer meets the definition of a standard agreement. If it does not, the CDM processes the offer through the Executive Board for authority to proceed.

The Executive Board hears the negotiation strategy for information and understanding and then decides whether the Commercial Evaluation Team should proceed into negotiations with the offeror. If yes, then negotiations proceed between the Commercial Evaluation Team and the offeror until an agreement is reached. If no, then a rejection letter is sent to the offeror.

When a commercial firm is ready to author an idea for submission as an entrepreneurial offer, several areas of information must be included in order for the offer to be considered. Eight primary components to an offer with several descriptive subcomponents are required and are as follows:

1. Offer description
 - Description of services provided
 - Terms and conditions of agreement
 - Time phase of agreement
 - Private investment
 - Services required from U.S. Government/NASA
 - Benefits to Government/NASA/public
2. Company information
 - Ownership
 - Location and facilities
 - Services provided
3. Technical information
 - Summary description of hardware and software
 - Summary description of operational concept
4. Market analysis
 - Market segmentation
 - Industry analysis
 - Customer base
 - Competition
5. Strategy summary
 - Pricing
 - Distribution strategy
 - Sale forecast
6. Financial plan
 - Capital investment plan
 - Contingency plan
 - Break-even analysis
 - Profit and loss
 - Projected cash flow
 - Projected balance sheet
7. Management team
 - Team members
 - Points of contact (business and technical)
 - Organizational structure

8. Exhibits

Federal, state, local regulatory approvals/awareness
Certifications

Currently, no defined format for offer submittals exists except that the description for each of the subcomponents be brief and concise.

3.2.2. Bibliography

Bush, Lance: Human Exploration and Development of Space (HEDS) Registration and Disposition Process for ISS Entrepreneurial Offers. HOWI 7020-U019 Baseline, NASA, Aug. 16, 1999.

3.3. Commercial Opportunities

By opening the ISS to commercial industry, NASA is presenting an enormous opportunity for industry in two primary ways. First, industry can utilize the ISS for their own for-profit ventures including developing, producing, and/or providing products and services to the government, academia, and the general public. NASA has begun to investigate various areas of industry that might utilize the ISS as described earlier. However, these areas are not all-inclusive as there may be ways to utilize the ISS that have yet to be considered. An initial study was conducted by NASA, which unveiled some of the opportunities on board the ISS in the areas described in the following sections.

The second opportunity for industry is to call on their advanced technologies that they have developed and offer or provide that technology for profit or in-kind trade to NASA to enhance the capabilities of the ISS. By examining the baseline information and comparing that with their own products and technologies, industry can position itself to provide products and/or services to NASA and the ISS. In this case, industry can also use this opportunity to market itself as being involved with the ISS. As most people worldwide are fascinated at the subject of the ISS and space, another positive in marketing and advertising can be obtained from enhancing the ISS with their technologies. Information from the documents listed in the bibliography (section 3.3.5) was used to compile this section.

Commercial Space Centers (CSC) are one way that industry, academia, and the government can form partnerships to support a variety of commercial research. These centers are currently located in different universities throughout the United States. Each center has its own research objective, whether it is space manufacturing, communications, or pharmaceuticals. Each of the CSC and affiliates have partnerships with industry and NASA as shown in the following tables:

Commercial Space Centers	School	Research objective
Center for Advanced Microgravity Materials Processing	Northeastern University	Space manufacturing
Center for BioServe Space Technologies	University of Colorado at Boulder Kansas State University	Pharmaceuticals
Center for Commercial Applications of Combustion in Space	Colorado School of Mines	Space manufacturing
Center for Macromolecular Crystallography	University of Alabama at Birmingham	Pharmaceuticals
Commercial Space Center for Engineering	Texas A&M University	Space manufacturing
Consortium for Materials Development in Space	University of Alabama in Huntsville	Space manufacturing
IDT ProVisions Technology Commercial Space Center	Stennis Space Center	Pharmaceuticals
Medical Informatics and Technology Application Center	Virginia Commonwealth University– MCV	Pharmaceuticals
Solidification Design Center	Auburn University	Space manufacturing
Space Vacuum Epitaxy Center	University of Houston	Space manufacturing
Wisconsin Center for Space Automation and Robotics	University of Wisconsin-Madison	Space manufacturing

Commercial Space Center Affiliates	School	Research objective
Center for Mapping	Ohio State University	Communications
Center for Satellite and Hybrid Communications Networks	University of Maryland at College Park	Communications
Center for Space Power	Texas A&M University	Space manufacturing
Center for Space Power and Advanced Electronics	Auburn University	Space manufacturing
Communications Technology Center	Florida Atlantic University	Communications

3.3.1. Communications

NASA envisions the future of the ISS communications and tracking system to evolve into a system that will enable science to users, enable broad public access using the Internet, and make a transition to a commercially provided capability. Enabling science to users would allow continuous orbital broadband coverage of ≈ 90 percent for ISS-ground facility data transfers to support real-time telescience, telemedicine, and video conferencing opportunities. This enhancement would also reduce data latency from experiment data and allow actual POIC data capture and analysis/transfer; direct prime investigator (PI) access to experiments and results via home/university/laboratory locations; and allow for Internet access to universities, laboratories, NASA centers, industries, the world.

Enabling broad public access through the Internet could allow for an ISS Internet Web page covering astronaut video, science summaries, and living-in-space documentaries. Public access could also enhance public interest and education and provide for Public Affairs Office (PAO) events, news, and video conferences.

Changing to a commercially provided capability could mean moving to Ka-band (or other) spectrum with functional capability to upgrade further. The ISS would become a leased user of commercial telecommunications services. The ISS becomes a resource for commercial systems to support commercial payloads and experiments. The ISS could utilize latest technologies in communications, leveraging on designs already anticipated or used, and provide a platform for expansion of capabilities in data communications.

In order for NASA to achieve these visions after assembly complete (AC) (>2005), partnerships between NASA and the commercial communications industry need to be fostered and an implementation groundwork needs to flow into current ISS schedules. Proactive industries need to work with NASA to define “reality” as to what can be accomplished and expected for data communications support in the post-2005 timeframe. For example, the Communications Technology Center is currently undertaking a project that deals with digital techniques for transmitting video, audio, and data to Earth by satellite. The Center for Satellite and Hybrid Communication Networks would utilize both satellite and terrestrial resources for communication networks. The Center for Mapping focuses on the science and technology of mapping applications. This Center conducts interdisciplinary research and provides educational opportunities within the interdisciplinary research center of Ohio State in the areas of Earth and space sciences and spatial data.

Commercial networks must be at or greater than TDRSS H, I, and J capability for coverage and bandwidth. Commercial telecommunications satellite networks must be real because commitment by NASA requires *strong* advocacy and will need long-term Industry sign-up and support. Finally, satellite design considerations need to permit ISS in low Earth orbit (LEO) as a high bandwidth user.

The following specifications are the future ISS performance needs in the post-AC timeframe as assessed by NASA: the ISS-to-ground real-time coverage must be ≈ 90 percent per orbit; the ISS will need Doppler compensation due to a moving ISS in LEO (≈ 450 km), and a moving constellation of satellites in LEO or medium Earth orbit (MEO). The current capabilities for forward link must be increased to at least 25 Mbps and the return link service should be at least 300 Mbps with an optimal goal of 1000 Mbps, and there must be an adequate link margin. Finally, the ISS-to-satellite-network and satellite-network-to-ISS tracking capability must be established.

One opportunity for the communications industry to enhance the capabilities of the ISS would be to utilize commercial telecommunication satellite systems as a supplement to ISS (as an alternate to TDRSS) communications. This technology could enable continuous point-to-point real-time communications with researchers or ground-based industry without having to completely rely on the TDRSS satellites (H, I, and J).

Another area for commercial venture would be to enhance communication capabilities of the ISS by means of advanced antenna technology. A concept for an advanced communications tower is presented in section 5, which considers a large antenna tower attached to the CAM for increased downlink capability. A refocus activity was spawned in the third quarter of 1999 to look at alternate locations for an ACT-like (advanced communication tower) system to be mounted on the ISS (e.g., a Z1 extension).

3.3.2. Pharmaceuticals

The opportunities for pharmaceutical companies to utilize the ISS manifest themselves in the search for and development of new drugs to combat disease. Researchers use the structural information of protein crystals to help design new medicines “that interact with specific sites on the protein molecule of interest.” The structural information of the laboratory-developed protein crystal is obtained through a process of X-raying the crystal, also known as X-ray crystallography. The quality of the laboratory-developed protein crystals is proportional to the quality of “the diffraction pattern produced by an X-ray diffraction system and ultimately on the atomic resolution that can be determined from these diffraction images.” Hence, the determination of the protein structure is directly dependant on the quality of the grown crystal. Through the NASA Space Shuttle Program in conjunction with the University of Alabama at Birmingham Center for Biological Sciences and Engineering (UAB CBSE), it has been proven that protein crystals grown in microgravity are larger, purer, and more perfectly arranged, and hence, allow for more accurate analysis. The minimization of gravity during the growth process reduces “buoyancy-reduced convective flows [that] lead to a slower, more consistent crystal growth: and reduces the amount of impurities.” Microgravity also allows for crystal sedimentation to be eliminated. Finally, growing crystals in a semicontainerless environment minimizes potential nucleation sites, which leads to fewer but larger crystals.

One of the problems encountered with the Space Shuttle is that the missions were not long enough for many types of proteins to grow to a usable size. Another concern with the Shuttle program in this area was the low amount of Shuttle flight opportunities. The limited number of flight

opportunities prevents researchers from performing the required iterative experiments to optimize crystallization conditions. These limitations are removed with the advent of the ISS. The ISS would allow for extended durations on-orbit which would provide solutions to both issues. The commercial pharmaceutical industry could greatly enhance the results of their research through the utilization of the ISS.

Several facilities are being developed for protein crystal development on the ISS. The dynamically controlled protein crystal growth (DCPCG) system is a new device under development at the UAB CBSE for use on the ISS as well as on the ground. The system can be configured to dynamically control either solution concentration or temperature. Using information from noninvasive diagnostics, active control of these parameters can, in real time, affect the supersaturation condition of the protein solution for both prenucleation and postnucleation phases.

The high-density protein crystal growth (HDPCG) system is also being developed at the UAB CBSE for commercialization activities planned for the ISS. The system has 1008 experiment chambers designed to be removable from the growth system and placed in an appropriate facility for on-orbit sample removal and analysis.

Finally, the X-ray crystallography facility (XCF), as described in detail in volume I, is being developed for use on the ISS. This facility will allow for the harvesting of crystals robotically from the HDPCG (or equivalent) chamber blocks and mount crystals selected by scientists on the ground for cryopreservation or X-ray analysis. This facility will allow for firms to obtain protein structures not resolvable on the ground, for a price yet to be determined. Also, firms and scientists would be able to obtain near to real-time results of the X-rays of the crystals without having to wait for the return of the crystal to perform the X-ray analysis terrestrially. Finally, the XCF will provide the necessary cryopreservation of macromolecular crystals to minimize or eliminate contamination or degradation of the crystals before they are returned to Earth for further analysis and study.

Other CSC's have been conducting research in additional areas that conduct business with the pharmaceutical industry. The Center for BioServe Space Technologies is focused on payload design, space flight access, and experiment definition and has affiliates with pharmaceutical firms, agricultural product companies, and medical research establishments to further expand the space frontier by developing powerful life science applications.

The Medical Informatics and Technology Application Center (MITAC) is concentrating on telemedicine, medical informatics, and medical technology through the Medical College of Virginia (MCV). It was established to develop, evaluate, and promote information and medical technology on the ground and in space. Yale University School of Medicine, the original MITAC, continues to support the development and evaluation of sensors, transmitters, effectors, and process simulators.

IDT ProVisions Technology Commercial Space Center is another CSC undertaking pharmaceutical interests. ProVision Technologies, a nonprofit division of the Institute for Technology Development, is committed to the development of biomedical applications using hyperspectral technology and works with private enterprises and affiliates in North America to investigate the possibilities of hyperspectral imaging for these private projects.

To take this one step further, pharmaceutical companies could potentially utilize the ISS in a manufacturing capacity for the manufacture of specialty medications that might need the

microgravity environment for production as well as research and development. Manufacturing possibilities are discussed in the next subsection.

3.3.3. Space Manufacturing

The area of space manufacturing is a relatively new concept, one which, based on studies that have been performed, is not readily accepted by industry at this point. The following section defines space manufacturing and describes some of the areas that might take advantage of the microgravity environment for manufacturing purposes. While this is certainly not all-inclusive, it is an initial representation of the opportunities for commercial space manufacturing that can be applied to the ISS environment and facilities.

The industry categories identified under the space manufacturing/processing general heading have mostly not been associated with the actual space scenario. Exceptions are microgravity processing and university/industrial R&D, the former being unique to the space environment and the latter comprising a small portion of the activity base.

The term “space manufacturing” is somewhat misleading, because it suggests an industry whereby an orbital asset (with an inherent microgravity environment) is used to support the making of “production” quantities of items by controlled processing of raw materials. These items or products are assumed to be characterized by structure and properties that cannot be duplicated in the unitary gravitational environment on Earth.

The misconception basically concerns the quantity of processed products considered to be of manufacturing production magnitude. For example, some pharmaceutical materials derived from space processing and intended for the treatment of critical human conditions have values up to \$15 million per pound (i.e., tissue plasminogen activator (TPA)).

In the context of this report, space “manufacturing” refers to the processes either of producing relatively small quantities of high-value materials in an orbital microgravity environment or of producing small quantities of pilot material with the intent of identification and analysis of the material’s three-dimensional molecular structure. Both categories of product would be returned to Earth but the latter materials would be uniquely characterized by analysis. The resulting knowledge base would be used for the development of new drugs, designed (via structured biology techniques) to interface with those molecular structures to produce beneficial therapeutic effects.

Space manufacturing is the use of the near-zero gravity and vacuum environment of space for production, processing, and manufacture of materials for commercial purposes. This is a very broad definition which includes industrial and research activities such as the zero-*g* production of metal alloys, plastics, or glass; processing and analysis of organic matter; and the study of the physiology and behavior of humans, animals, and plants in the unique environment of space. For example, the Center for Commercial Applications of Combustion in Space (CCACS) has been conducting combustion research to help industry develop commercial products that are mainly involved with energy, materials, minerals, and the environment. This Center is currently working on improving the combustion process. The CCACS is trying to develop new, better, more efficient, and less polluting to the environment combustion-related products and processes. Another example is the Center for Space Power that has developed or is currently developing advanced technologies which include specialized heat pipes, advanced battery components, novel electronic materials, digital communications algorithms, power conditioners, and many complex power-related devices. Although space provides a whole new realm of opportunity and a vast potential

market for U.S. industry and businesses, it is still perceived by many as “the final frontier” or as a medium to express U.S. leadership and technology rather than an economic market ripe for expansion. This idea is reinforced by the tremendous costs of today’s space infrastructure, elements such as cost per pound launched, cost of electricity generated in space, launch expenses, and safety requirements.

In order to fully allow and facilitate the commercialization of the tremendous potential market of space, the cost of the basic space infrastructure must be reduced dramatically. The government will also be required to play a role to promote, entice, and aid the development of a private sector presence in space. The Commercial Space Center for Engineering (CSCE) examines the experiment options and costs for industry clients, always keeping the clients’ constraints in mind. The main focus of the CSCE is to utilize the platforms of the ISS to experiment on new or emerging technologies for industry payload research.

The unique near-zero gravity of space would allow industries to manufacture new materials simply due to the fact that the absence of gravity allows for the creation of perfectly even and consistent mixtures of materials with vastly different mass and densities. These alloys would have “unique physical properties no nation on Earth could duplicate” and could lead to the production of much faster computers, smaller and much more powerful batteries that could power future electric cars, and many other new products.

It would be useful at this point to summarize a sample of the potential advantages and products that may be produced in a microgravity environment.

1. Immune response understanding leading to viral infection antibodies or vaccines
2. Synthetic production of collagen for use in constructing replacement human organs (e.g., corneas)
3. Manipulated differentiation of plant cells to produce desired chemicals (e.g., cancer-killing drugs)
4. Production of targetable pharmaceuticals (cancer cures)
5. Protein crystal formation for structure identification (structured biology)
6. Protein assembly
7. Growth of large pure electronic, photonic, and detector crystal materials (computer chips, quantum devices, infrared materials)
8. Ultrapure epitaxial thin film production in very high vacuum (e.g., wake shield facility)
9. Production of perfect solid geometric structures
10. Manufacturer of pure zeolite crystal material for filtration applications (pollution control)
11. Manufacture of polymers with unique characteristics
12. Electrophoresis for separation of microscopic components within fluids

Another potentially profitable space activity is the disposal of nuclear waste and other hazardous materials. The disposal of hazardous waste material has long been a problem for government and industry and continues to be today. A report by the Aerospace Research and Development Policy Committee of IEEE, Inc. projects that “by the year 2000 the accumulation of irradiated fuel from commercial nuclear plants alone will approach 200 thousand metric tons and will be increasing at a rate of 10 thousand metric tons per year.” With the development of new technology and reduced costs, the potential to transport hazardous materials into space from remote locations on Earth and the propulsion of this material into far-out orbit can become a realistic and desirable option.

Space can also provide an optimum location for orbiting platforms that can be used to transmit electrical energy via optical mirrors and microwave energy transmission technology. This electrical energy can then be sent from remote sources on the surface of the planets to the locations where it is needed. This would provide a new and environmentally safe method of electrical power generation and transmission.

3.3.4. Entertainment and Tourism

The areas of entertainment and tourism are being seriously considered as viable economic markets. Although the ISS currently has little resources or facilities for these areas, commercial industry is already considering the possibility of utilizing the ISS for these endeavors.

The entertainment industry can utilize the ISS in several different ways including entertainment and educational broadcasting, advertisement, delivering space-related news, and even potentially making TV shows and movies on the ISS. To this end, already, the company Spacehab, Inc., has made an arrangement with the Russian Space Company, Energia Rocket and Space Corporation, to establish the first commercially available module on the ISS. This module will be made available to all the commercial markets on Earth. One of the areas provided to commercial industry will be the ability to broadcast from the ISS. This capability will be very appealing to the entertainment industry and will be the initial step towards a full space-based entertainment venture.

Tourism in space may also prove to be a viable market for new space industries. There are approximately 250 million people worldwide that can be targeted as a potential market for space tourism. There have already been fortunate individuals who can be considered “paying tourists” who have visited the Russian Space Station Mir. If the costs of the space infrastructure are drastically reduced and the safety levels are increased, tourism in space could be a tremendous market for industry.

Currently, companies exist which are taking reservations and down payments for suborbital and orbital trips to space. Although the facilities and vehicles are not yet available for such trips for the common person, efforts continue between these private companies and NASA to make these visions a reality. Additionally, other companies, both American and Japanese, are planning space-based hotels. Artist concepts and designs are in work. Private funding is backing these efforts. Again, the main drawback at this time is the individual cost of getting items and people into space.

Although these ideas will not become reality for quite some time, it is essential that visionary and planning efforts begin now. Without these visions and dreams, these areas of utilization of the ISS and of space will never be realized.

Many ideas and strategies have been proposed and in some cases placed into action in order to take advantage of the bountiful prospects of the space market. A fundamental aspect of all these innovative plans is the reduction and minimization of costs; thus, economy and efficiency become a primary concern. Several proposals are now being discussed to accomplish these space manufacturing goals.

3.3.5. Bibliography

Anon.: BioServe Space Technologies. <http://www.colorado.edu/engineering/BioServe/> Accessed Aug. 29, 2000.

Anon.: CAMMP—Center for Advanced Microgravity Materials Processing. http://www.dac.neu.edu/cammp/CAMMP_description.htm Accessed Sept. 6, 2000.

Anon.: CCACS—The Center for Commercial Applications of Combustion in Space. <http://talus.Mines.edu/research/ccacs/> Accessed Sept. 6, 2000.

Anon.: The Center for Macromolecular Crystallography Partnerships: A Productive and Cost-Effective Approach to Drug Design. <http://cmc.uab.edu/brochure/brochure.html> Accessed Aug. 29, 2000.

Anon.: The Center for Mapping at The Ohio State University. <http://www.clm.ohio-state.edu/homepage.html> Accessed Aug. 29, 2000.

Anon.: Center for Space Power—NASA Commercial Space Center. The Texas A&M University System. http://engineer.tamu.edu/tees/csp/csp_home.html Accessed Aug. 29, 2000.

Anon.: Commercial Space Centers—Partnering With Industry for “Out of This World” Results! <http://spd.nasa.gov/csc.html> Accessed Aug. 29, 2000.

Anon.: Commercial Space Transportation Study, NASA, 1993.

Anon.: Communications Technology Center. Imaging Systems Laboratory, Florida Atlantic University. <http://www.fau.edu/divdept/comtech/ctchome.html> Accessed Aug. 29, 2000.

Anon.: Department of Surgery—Virginia Commonwealth University Medical College of Virginia Campus. Medical Informatics and Technology Applications Consortium. <http://www.surgery.vcu.edu/res-mitac.htm> Accessed Aug. 29, 2000.

Anon.: International Space Station Commercial Development. <http://commercial.hq.nasa.gov/links.html> Accessed Aug. 29, 2000.

Anon.: NASA Microgravity Research Facilities. <http://zeta.lerc.nasa.gov/kjenks/microg-f.htm> Accessed Aug. 29, 2000.

Anon.: Office of Space Access and Technology—Space Experiment Facility (SEF). <http://www.uah.edu/research/cmds/projects/sef.html> Accessed Sept. 6, 2000.

Anon.: Overview: Enterprise™—The Commercial “Portal” to the Space Station. <http://www.spacehab.com/enterprise/overview.html> Accessed Sept. 6, 2000.

Anon.: Space Power Institute (SPI)—Auburn University. <http://spi.auburn.edu/> Accessed Aug. 29, 2000.

Space Vacuum Epitaxy Center. <http://www.uh.edu/research/svec>.

Anon.: The Texas A&M University System—Texas Engineering Experiment Station. <http://teesweb.tamu.edu/> Accessed Aug. 29, 2000.

- Anon.: Trends in Commercial Space 1996: Space Manufacturing and Processing. <http://www.ta.doc.gov/oasc/tics/spcmfg.htm> Accessed July 18, 2000.
1. 1994 Industrial Outlook, Space Commerce, p. 28-1.
 2. Aerospace Research and Development Policy Committee of IEEE, What the United States Must Do To Realize the Economic Promise of Space, Dec. 1993.
 3. "Newt in Space," Gene Myers, Jan. 1994.
 4. Aerospace Research and Development Policy Committee of IEEE, What the United States Must Do To Realize the Economic Promise of Space, Dec. 1993. pp. 19–20.
- Anon.: The University of Alabama in Huntsville Research Centers Laboratories and Consortia. <http://www.uah.edu/research/cmds/projects/sef.html> Accessed Sept. 6, 2000.
- Anon.: Welcome to Metal Casting R&D at Auburn University. <http://metalcasting.auburn.edu/> Accessed Sept. 6, 2000.
- Anon.: Welcome to SPACEHAB. <http://www.spacehab.com/main/main.htm> Accessed Sept. 6, 2000.
- Anon.: Wisconsin Center for Space Automation and Robotics. Commercial Activities. <http://wcsar.engr.wisc.edu/activities.html> Accessed Aug. 29, 2000.
- Anon.: Wisconsin Center for Space Automation and Robotics. Commercial Plant Biotechnology Facility (CPBF). <http://wcsar.engr.wisc.edu/cpbf.html> Accessed Aug. 29, 2000.
- Hadjitheodosiou, Michael: University of Maryland Center for Satellite and Hybrid Communication Networks. <http://www.isr.umd.edu/~michalis/satellite> Accessed Aug. 29, 2000.
- ProVision Technologies: Hyperspectral Imaging Advanced Clinical Detection. <http://www.pvtech.org/> Accessed Aug. 29, 2000.
- Stillwagen, Frederic H.: ISS Communications Transition to the Future: Advanced Communications System. Sub-Session I, Space Technology and Applications International Forum 2000: Commercial Communications Systems for the International Space Station, Feb. 3, 2000.

4. ISS Enhancement Technologies

The ISS enhancement technologies are those technologies that have moved beyond the discussion and conceptual phases of the P³I technologies and are being developed for future use on the ISS. These projects have funding for design, build-up, and testing of engineering, protoflight, or flight hardware. Even though these technologies are not part of the baseline design of the ISS, they are being planned for addition after assembly complete. Information from the document listed in the bibliography (section 4.2) was used to compile this section.

4.1. Flywheel Energy Storage for ISS

4.1.1. Introduction

A flywheel is a device that, by virtue of its rotation, possesses kinetic energy and angular momentum. A motor can be used to increase the kinetic energy of the flywheel, and a generator permits the kinetic energy to be converted back to electrical energy. In accordance with the law of action and reaction, torque exerted on the flywheel through a motor or generator is applied, in equal magnitude and opposite direction, to the body in which the motor or generator is mounted. Thus, a flywheel can be used aboard a spacecraft for energy storage and attitude control. The flywheel belongs to the class of attitude control actuators known as momentum exchange devices which includes reaction wheels and control moment gyroscopes; however, these devices in common use today do not allow the conversion of kinetic energy back into usable electrical energy.

Use of flywheel-based integrated power and attitude control systems (IPACS) technology has been examined, and it has been concluded that flywheels will likely have an advantage over chemical battery technology for applications with a large number of charge-discharge cycles, such as spacecraft in LEO. IPACS are made up of two or more (usually more) flywheels used both to store and discharge energy and to exert torque to control the attitude of a spacecraft. The technology is applicable to a full spectrum of Mission to Planet Earth LEO spacecraft, assuming that a range of flywheel sizes is produced by industry. Potential applications in the NASA Human Exploration and Development of Space Enterprise include future launch vehicles and space stations.

NASA flywheel development efforts today are aimed at increasing the performance of flywheels so that they can be used as efficient energy storage devices in aerospace power systems. In spacecraft, these advanced aerospace flywheels will be able to store energy more efficiently than rechargeable chemical batteries, and provide better attitude control than CMG's or reaction wheels.

4.1.2. Flywheel Energy Storage for the ISS

The Glenn Research Center is leading the development of a flywheel energy storage system for the ISS under the ISS engineering research and technology (ER&T) program. This effort, previously called the attitude control and energy storage experiment (ACESE), has been renamed the FESS. The new name reflects a change in emphasis for the project away from a reduced scale experiment to a system that will be appropriately sized to meet ISS primary energy storage needs. Studies have shown significant potential life cycle cost savings could be realized by taking advantage of the long cycle life inherent in flywheel technology. Maintenance and logistic costs associated with battery replacement would be eliminated because, once in place, flywheels will last the life of the ISS, whereas batteries are only expected to last 5 yr. A working development flywheel unit has been assembled and demonstrated under a cooperative agreement with U.S. Flywheel Systems, Inc., and the Boeing Company. Plans include ground demonstration of an engineering model flywheel system in the ISS space power electronics laboratory at the end of 2001 to be followed by a demonstration on the ISS slated for 2004 or 2005. The Air Force Research Laboratory (AFRL) Phillips Research Site is cosponsoring this project.

Efforts to achieve a full flywheel operational speed of 60000 rpm on magnetic bearings are near completion. U.S. Flywheel Systems, Inc. (USFS), with assistance from NASA and Texas A&M University Center for Space Power, has refined a multiple-input-multiple-output (MIMO) control scheme for flywheel magnetic bearing suspension to increase the efficiency of the

algorithms and reduce the required computational power. It is believed that 60000 rpm will establish a new benchmark for a fully integrated flywheel system using a complete composite rotor. The milestone of 60000 rpm has already been reached on magnetic bearings using a low inertia shaft. These development units set the current benchmark of 40000 rpm in an earlier configuration.

The Engineering Research and Technology Group has three objectives for enhancing energy storage on the ISS with flywheel technology: (1) provide a flywheel energy storage option to upgrade the ISS electrical power system, (2) design the flywheels to have increased energy storage capacity for payload use during contingency operations (as compared with the ISS baseline system), and (3) show that this technology can save hundreds of millions of dollars in logistics and maintenance costs for the ISS over its service life.

Through a combination of ground tests and weightless tests in aircraft of the magnetic bearings, FESS will be demonstrated as ready for space flight. Rotor safety will be assured by designing the rotors to fail structurally at angular speeds much higher than the maximum operating speed, and extensive testing will be performed to verify the design. The resources of government and industry are combined in support of FESS: GRC, JSC, AFRL Phillips Research Site, TRW, Inc., Boeing Company, U.S. Flywheel Systems, Inc., and the University of Texas Center for Electromechanics. Finally, solid technical milestones will be established to measure project progress.

During the initial on-orbit demonstration, a flywheel unit will be connected to the ISS electrical power system at the direct-current switching unit (DCSU) and operate in parallel with the existing battery charge-discharge units (BCDU's). Eventually, all batteries and BCDU's may be replaced with flywheel ORU's.

4.1.2.1. Flywheel Energy Storage Concept

For space applications, a flywheel-based system used only for cyclic storage and discharge of energy implies the use of at least two flywheels in a counterrotating configuration so that the torque and momentum vectors of one flywheel can cancel those generated by the other. The net torque and momentum generated by the pair are controlled so as to be effectively zero.

Figure 4.1-1 depicts the key components of a flywheel. Aerospace flywheels can be made in many different configurations but always include four main components. The rotor is the complete rotating assembly. The rim is the main rotating portion of the rotor; most of the stored energy is contained in the rim. The shaft is that portion of the rotor that lies on the spin axis of the rotor and is the rotor interface to the stator portions of the magnetic bearings and motor generators. Not all rotor designs require a shaft. Finally, the hub is the part of the rotor that connects the rim to the shaft. Since the hub mass contributes minimally to the stored energy, it should be as light as possible.

Successful development of advanced flywheels for future space missions provides the following significant advantages over technologies of today:

- >10× increase in specific energy (saves mass)
- Long cycle life enables longer LEO missions (saves cost)
- Increased efficiency (saves power)

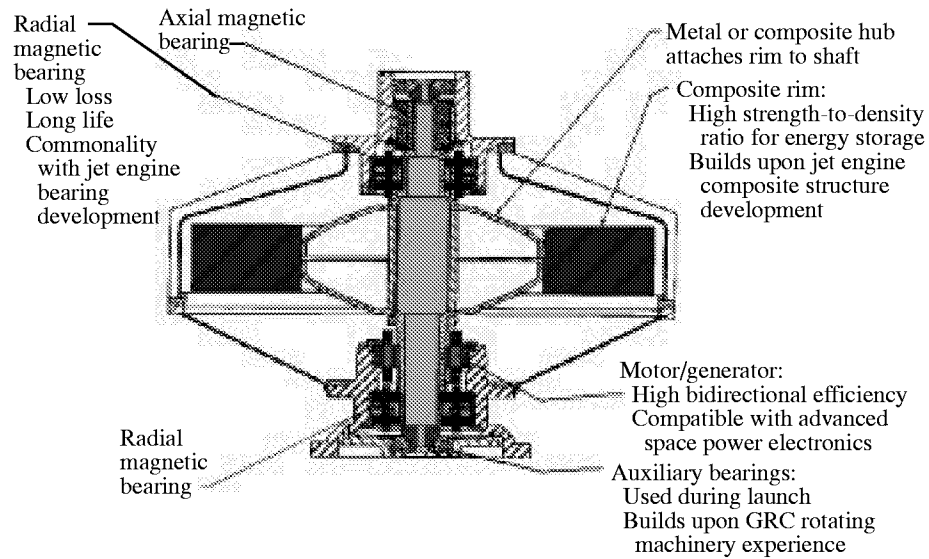

Figure 4.1-1. Components of flywheel system.

- Smaller volume (improves packaging)
- Power peaking capability for advanced launch vehicles, etc.

4.1.2.2. Storing Energy More Efficiency

In spacecraft, a significant benefit can be gained by combining energy storage with attitude control functions. Flywheel-based IPACS are highly supportive, and in some cases, enabling for current NASA, USAF, and industry goals of devising lighter and lower cost spacecraft while retaining significant capability. Commercial satellite manufacturers are extremely interested in this innovative technology to help retain their competitive advantage over foreign firms. In fact, many benefits are of interest to spacecraft mission and hardware designers. Table 4.1-1 summarizes the advantages of the electrical power system (EPS).

Table 4.1-1. Electrical Power System Advantages

Energy storage characteristics	Resulting benefits
5–10+ times greater specific energy	Lower mass
Long life (15 yr) unaffected by number of charge-discharge cycles	Reduced logistics, maintenance, life cycle costs, and enhanced vehicle integration
85–95 percent round-trip efficiency	More usable power, lower thermal loads, compared with <70–80 percent for battery system
High charge–discharge rates and no taper charge required	Peak load capability, 5–10 percent smaller solar array
Deterministic state of charge	Improved operability
Inherent bus regulation and power shunt capability	Fewer regulators needed

4.1.2.3. Usable Specific Energy Comparison

Significant benefits that become apparent at the spacecraft system level are not necessarily obvious at the component level. Specific energy, in general, is stored energy divided by mass of the hardware used to store the energy. The total specific energy of the flywheel system for the ISS is the total energy stored in the rotor divided by the total mass of the flywheel system. Usable specific energy of the flywheel is the energy delivered to the power bus (after accounting for depth-of-discharge limitations and electronics losses) divided by its mass. (See fig. 4.1-2.)

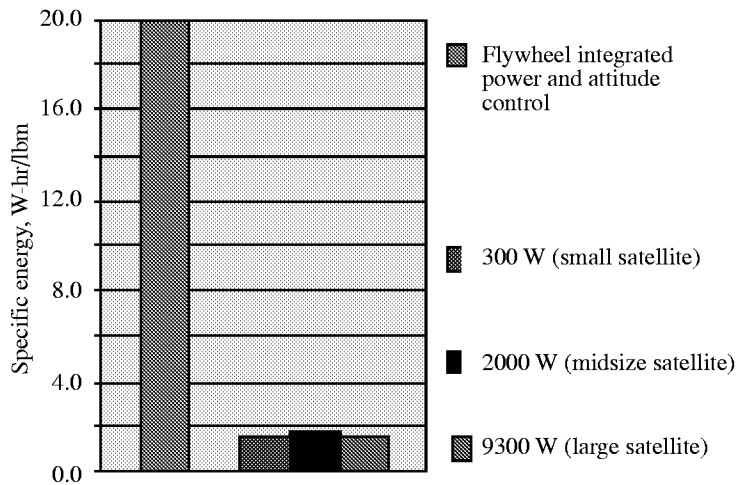

Figure 4.1-2. Flywheel energy.

Benefits for energy storage only are

- Very high usable specific energy: saves mass

- Higher efficiency: saves power

- Long life: 15 yr in LEO

- Less volume than nickel hydrogen batteries

- Known state of charge

Benefits for integrated attitude control are

- All items for energy storage only

- Higher specific energy

- Combined functions: less total hardware

4.1.2.4. Improvements in Attitude Control

Advantages over existing attitude control systems (ACS's) using control moment gyroscopes (CMG's) or reaction wheels are given in table 4.1-2.

Table 4.1-2. Attitude Control System Advantages

Attitude control characteristics	Resulting benefits
Long life	Reduced logistics, maintenance, and life cycle costs
Large control torques	Reduced propellant needs (flywheels can handle requirements that previously demanded propulsion systems)
Large momentum storage capability	Reduced propellant needs (flywheels can handle requirements that previously demanded propulsion systems)
Magnetic bearing suspension reduces vibration	Improved sensor payload performance and microgravity environment

4.2. Bibliography

Christopher, Dave: Aerospace Flywheel Development Program. Updated Nov. 1, 1999. <http://godzilla.lerc.nasa.gov/ppo/flywheel/fly.html> Accessed July 19, 2000.

5. Design Reference Missions for ISS Evolution

5.1. Introduction

Improvements in ISS systems and operations are being developed through the P³I Working Group. ISS enhancements are also being planned to accommodate commercial applications and HEDS mission support. Synergistic evolution of the ISS requires coordination of P³I technology development with the HEDS advanced mission accommodations and utilization and commercialization activities. The LaRC ISS Working Group is facilitating this coordination by developing and maintaining this ISS Evolution Data Book for NASA Headquarters, Code M. The DRM's are being defined and analyzed to identify synergistic technology investments that can augment performance of the ISS to most cost-effectively support future HEDS, commercialization, and utilization efforts. These DRM's will be used to identify technology investment and commercialization opportunities for the ISS. Current DRM's include commercial TransHab utilization, application of P³I technology road maps, accommodation of an ACT, accommodation of free flyers, and satellite servicing. The set of DRM's will continually evolve as the ISS is assembled and operated.

The preliminary drafts of DRM's, which do not represent any officially sanctioned path for ISS evolution, represent current advanced concept studies for ISS post-AC utilization and enhancements. The depth, scope, and quantity of the DRM's will be enhanced as information becomes available. The P³I technology road maps have been included in section 2.1.2 so that other potential ISS enhancements can be used to assess impacts to future transportation architectures.

5.2. Implementation of Energy Storage Enhancement as a P³I Technology

5.2.1. Description

TBS

5.2.2. ISS Enhancement Goal

The energy storage enhancement activity has the goal of inserting an enhanced energy storage option into the ISS EPS in order to increase power available on the ISS and to reduce operational costs. The primary options currently under consideration are enhanced or advanced batteries and the use of mechanical flywheels. By increasing specific energy (watts-hour per kilogram or watts-hour per pounds mass) and energy density (watts-hour per liter) in the enhanced batteries, battery life will be extended, and resupply ORU mass and volume and crew time for maintenance change-outs will be reduced.

5.2.3. Enhancement Specifications

5.2.3.1. Physical Description

Three enhanced energy storage options are currently being studied in the P³I program.

Enhanced baseline battery (NiH₂): These enhancement options include a modification of the electrolyte concentration and two design modifications of the pressure vessel containment. These enhanced batteries are manufactured by Eagle-Picher Industries, Inc. The enhanced batteries offer modest increased energy storage capacity but require the least amount of development.

Advanced technology battery (i.e., lithium ion, lithium polymer): P³I advanced technology batteries are all focused on lithium cells, with variations on the opposing electrode and electrolyte. The lithium polymer configuration of 3M, for example, uses a solid polymer foil as the electrolyte, which disperses and recombines during the charge-discharge cycles. This design has a significant safety advantage over other lithium batteries because there are no pressure vessels to contain nor leakage concerns. This technology area benefits from a diverse and aggressive development effort in the aerospace sector. Compared with the baseline ISS batteries, theoretical and demonstrated energy storage capacity of three to four times and energy density of over two times appear realistic but still require life-cycle testing.

5.2.3.2. Functional Description and Assumptions

The functional description and primary assumptions are as follows:

Enhanced baseline battery (NiH₂): The design driver for the enhanced baseline batteries is to increase the specific energy capacity of the battery; thereby a lower depth of discharge (DOD) is allowed for the same mass of battery. Because the primary cell failure mechanism is cycling at a high DOD, reducing nominal DOD results in an increase in battery life.

Advanced technology battery (i.e., lithium ion, lithium polymer): Similar to the enhanced NiH₂ battery, the design driver is to increase the specific energy capacity of the battery. Two performance approaches are possible: use the increased energy storage ratings to decrease the mass and volume of the batteries on orbit or use the same mass and volume of advanced batteries to increase peak energy capability and to decrease nominal DOD. The primary assumptions for the insertion of advanced batteries are that they will be ready (mature) by the time the baseline batteries require changeout and their use will require minimal modification to the baseline EPS design and control. Although indications are that the technology readiness level (TRL) of many of these batteries will allow their use, the high-temperature operation of the lithium polymer battery raises questions about system modifications to accommodate them.

5.2.4. Interface Requirements

The interface requirements for the advanced batteries are given.

Enhanced baseline battery (NiH₂): All interfaces are the same (big advantage) as the baseline batteries except for a minor additional software interface for the single-pressure vessel (SPV) design. The SPV design will require some additional monitoring of critical cell operational parameters.

Advanced technology battery (i.e., lithium ion, lithium polymer): Potential negative impacts exist in the interface area for advanced batteries. For example, the lithium polymer design with the solid polymer has an operational temperature of 80°C as opposed to baseline station batteries at around 0°C. This temperature requirement would require a separate mounting structure than the other EPS components on the integrated equipment assembly (IEA). An integrated energy analysis would have to be done to determine thermal control interface requirements. The software interface would likely be designed to be a transparent change to ISS.

5.2.5. Enhanced ISS Configuration Description

The enhanced ISS configuration will be the same as the baseline ISS configuration except for minor modifications as discussed in section 5.2.4.

5.2.6. ISS Impacts

This section identifies any impact that a change made because of enhancement has on the ISS.

5.2.6.1. Installation

Enhanced baseline battery (NiH₂): No impact.

Advanced technology battery (i.e., lithium ion, lithium polymer): No identified impact, although thermal requirements for some battery choices may complicate installation (i.e., separate cold plate, radiator).

5.2.6.2. Vehicle Configuration

5.2.6.2.1. Mass Properties

No impact.

5.2.6.2.2. Flight Attitude

No impact.

5.2.6.2.3. Control

No impact.

5.2.6.2.4. Orbital Lifetime

No impact.

5.2.6.3. Operations

5.2.6.3.1. Intravehicular Activity

No impact.

5.2.6.3.2. Extravehicular Activity

Enhanced baseline battery (NiH₂): Slight reduction in EVA due to improved reliability.

Advanced technology battery (i.e., lithium ion, lithium polymer): There will be potential large savings of EVA because of extended lifetimes.

5.2.6.3.3. Ground Support Operations

No impact.

5.2.6.3.4. Visiting Vehicle Operations

No impact.

5.2.6.4. Utilization

5.2.6.4.1. Microgravity

No impact.

5.2.6.4.2. Payload Accommodations

No impact.

5.2.6.4.3. Payload Operations

No impact.

5.2.6.5. ISS Subsystem Impacts

5.2.6.5.1. Command and Data Handling

No impact.

5.2.6.5.2. Communications and Tracking

No impact.

5.2.6.5.3. Crew Systems

See section 5.2.6.3.2.

5.2.6.5.4. Environmental Control and Life Support Systems

No impact.

5.2.6.5.5. Guidance, Navigation, and Control

Enhanced baseline battery (NiH₂): No impact.

Advanced technology battery (i.e., lithium ion, lithium polymer): No impact.

5.2.6.5.6. Power

See sections 5.2.3.1 and 5.2.3.2.

5.2.6.5.7. Propulsion

No impact.

5.2.6.5.8. Robotics

No impact.

5.2.6.5.9. Structures and Mechanisms

No impact.

5.2.6.5.10. Thermal Control

Enhanced baseline battery (NiH₂): No impact.

Advanced technology battery (i.e., lithium ion, lithium polymer): See “Advanced technology battery” in section 5.2.4.

5.3. ISS Free-Flyer Satellite Servicing

5.3.1. Description

The ISS, once operational, may provide the capability to service various visiting vehicles that are in a relatively similar orbit to the Station. Servicing would include changeout of payloads, replenishment of consumables, repair, and refurbishment operations. Information from the documents listed in the bibliography (section 5.3.7) was used to compile this section.

5.3.2. ISS Enhancement Goal

The goals of ISS free-flyer satellite servicing are as follows:

1. Provide enhanced science and manufacturing capabilities with free-flyer unique features: ISS-tended free-flying spacecraft will provide the experiment payload community with unique research capabilities such as a longer duration microgravity environment with minimal disturbances, additional flexibility of operations, enhanced pointing capability, altitude adjustment, and low contaminate levels around the free flyer (FF)
2. Provide ISS risk mitigation opportunities: In addition to science research capabilities, ISS-tended free flyers will be used to investigate risk mitigation technologies for ISS such as advanced propulsion and structures
3. Reduce the Space Transportation System (STS) upmass and downmass for launch and landing requirements: Maintaining free-flying spacecraft from the ISS instead of returning them to Earth will provide enhanced ISS capability and reduce the upmass and downmass for the STS

5.3.3. Enhancement Specifications

5.3.3.1. Physical Description

Unpressurized FF's would be berthed to attached payload or cargo locations on the ISS truss (S3 and P3). Four attached payload sites are defined for S3 (fig. 5.3-1) and two cargo locations for

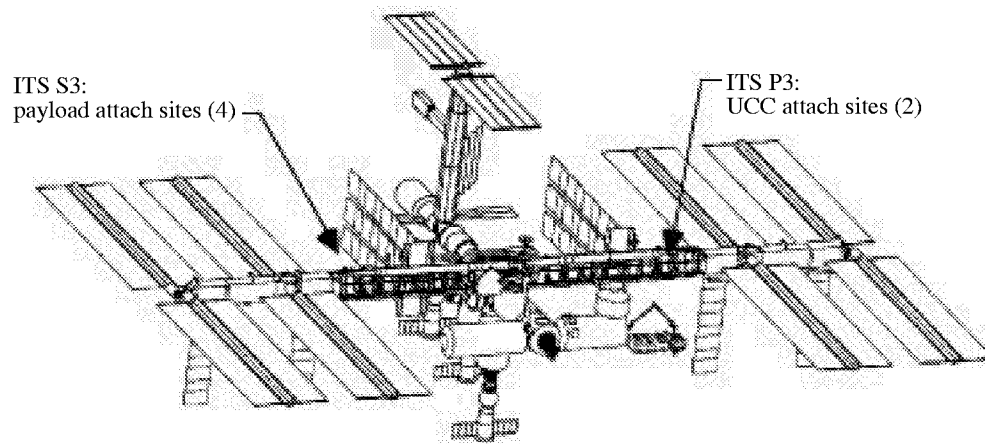

Figure 5.3-1. Attached payload sites for S3.

P3. However, current planning indicates potential oversubscription of these sites. Other potential locations for free-flyer servicing may include the Japanese experiment module (JEM) exposed facility (EF), the planned European attached facility, and additional sites on the truss.

ISS free-flyer satellite servicing would leverage the use of existing attached payload components: Station (expediting the processing of experiments to Space Station (EXPRESS)) pallets, unpressurized logistics carriers (ULC), and the SPACEHAB integrated cargo carrier (ICC). The EXPRESS pallets (ExP) (fig. 5.3-2) and ULC's may be used for storing consumables and hardware for changeout. The ICC could be used to transport consumables and hardware on the STS (fig. 5.3-3).

Attached payload system components, such as the payload attachment system (PAS) passive mechanism, the umbilical mechanism assembly (UMA) interface, and EXPRESS pallet adapters (ExPA's), may also be incorporated into free-flyer designs. The PAS and UMA could be used on FF's to allow berthing to an attached payload location (fig. 5.3-4). ExPA's (or similar hardware) may also be incorporated into the free-flyer designs to simplify changeout of payloads and consumables (fig. 5.3-5).

5.3.3.2. Functional Description and Assumptions

A free-flying spacecraft, after completing its initial mission, would move from its operational orbit to the ISS orbit. Consumables and hardware for changeout, previously delivered by the Shuttle, would be waiting at the ISS on an ExP or ULC. After the FF is maneuvered to the appropriate

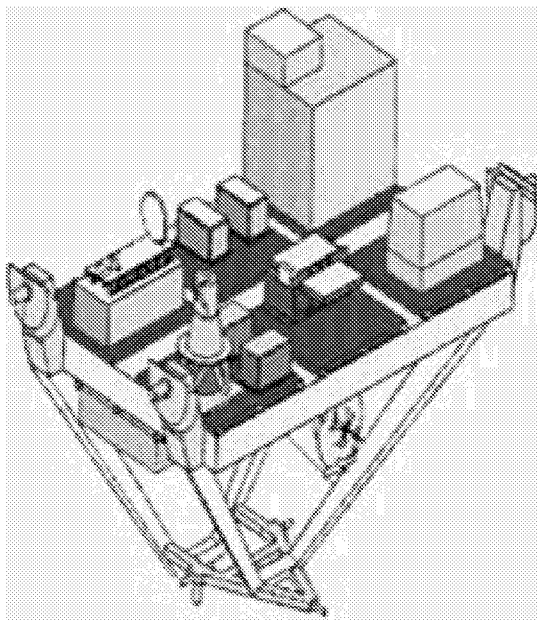

Figure 5.3-2. EXPRESS pallet.

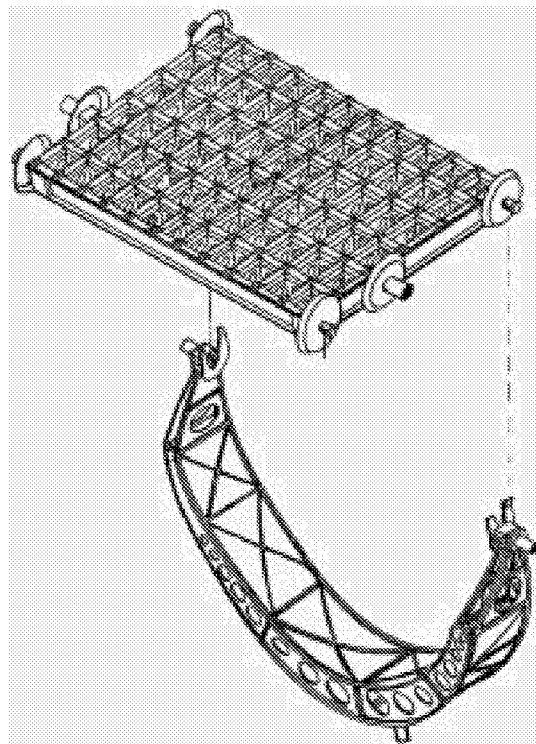

Figure 5.3-3. SPACEHAB ICC.

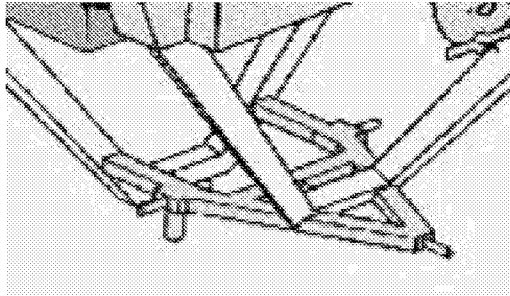

Figure 5.3-4. PAS /UMA.

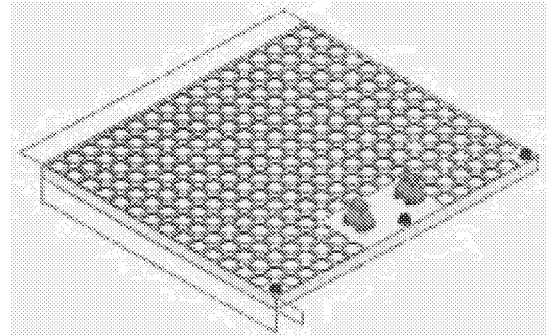

Figure 5.3-5. ExPA.

area, the Space Station remote manipulator system (SSRMS) would be used to berth the FF to the ISS attached payload location. The ISS crew would use the SSRMS to exchange payloads, systems, and consumable containers. A checkout of the FF would be conducted prior to release from ISS. The SSRMS would then release the FF, which would return to its operational orbit.

The following assumptions were made:

- The free-flyer servicing capability will be configured, deployed, and utilized after ISS AC
- A free-flying spacecraft will contain a propulsion system to maneuver from its operational orbit to the ISS orbit
- A free-flying spacecraft will be capable of automated and onboard (ISS) control for proximity operations
- The free-flying spacecraft will be berthed at a designated attached payload location where servicing activities will be conducted
- The ISS will provide an additional attached payload location for stowage of free-flyer consumables and experiment hardware
- Free-flyer design will allow maximum use of SSRMS for servicing activities and will only require EVA for contingency operations

5.3.4. Interface Requirements

The external free-flyer servicing requires two attached payload locations: one for berthing of the spacecraft and the other for storage of an ExP or ULC containing the consumables and equipment for changeout. The spacecraft, consumables, and equipment will provide SSRMS-compatible grapple fixtures to support servicing activities.

The free-flyer servicing will not require direct internal interfaces with the ISS. However, FF's will be required to be compatible with the ISS communications system for control during proximity operations.

5.3.5. Enhanced ISS Configuration Description

The enhanced ISS configuration will be the same as the baseline ISS configuration. The free-flyer servicing capability would utilize existing attached payload accommodations, and the hardware would fit within the associated envelopes.

5.3.6. ISS Impacts

5.3.6.1. Installation

Consumables and hardware for changeout, attached to an ExP or ULC, would be delivered by the Shuttle, and berthed to an attached payload location on the ISS, by using the SSRMS. FF's would rendezvous and be berthed to ISS as described in section 5.3.3.2.

5.3.6.2. Vehicle Configuration

5.3.6.2.1. Mass Properties

An FF, including ISS interface hardware, will have a mass no greater than the maximum allowable capability of the attached payload location of approximately 4500 kg. The ExP or ULC containing the consumables and equipment for changeout will also have a mass no greater than the maximum allowable capability of the attached payload location.

5.3.6.2.2. Flight Attitude

TBD

5.3.6.2.3. Control

TBD

5.3.6.2.4. Orbital Lifetime

The free-flyer servicing capability could be available from AC throughout the orbital lifetime of the ISS. Each FF will have a particular orbital lifetime associated with its specific mission.

5.3.6.3. Operations

5.3.6.3.1. Intravehicular Activity

Intravehicular activity (IVA) would be required for control of FF during proximity operations and to control the SSRMS in the berthing of a spacecraft to an attached payload site.

5.3.6.3.2. Extravehicular Activity

EVA would be required only in situations where the SSRMS cannot be used and in situations where the SSRMS has failed.

5.3.6.3.3. Ground Support Operations

Ground control would initiate the FF to move from its operational orbit to the ISS orbit. Control would be handed over to ISS IVA crews for proximity operations.

5.3.6.3.4. Visiting Vehicle Operations

The FF would adhere to all ISS visiting vehicle requirements.

5.3.6.4. Utilization

5.3.6.4.1. Microgravity

Free-flyer servicing activities (berthing, consumable replenishment, hardware changeout) will be limited to defined time periods outside the ISS “quiescent” period to prevent disturbance of the ISS microgravity environment.

5.3.6.4.2. Payload Accommodations

ISS-attached payload accommodations would be used to implement the servicing capability; however, the loss of payload accommodations on the ISS would be offset by the additional payload accommodations provided by the FF's. The associated advantages (longer duration microgravity environment, flexibility of operations, enhanced pointing capability, altitude adjustment, and low contaminate levels) of the FF's would also offset the loss of attached payload accommodations.

5.3.6.4.3. Payload Operations

Attached payloads at locations adjacent to free-flyer servicing areas may need to suspend operations during proximity, capture, and servicing to avoid potential contamination of optics and sensors.

5.3.6.5. ISS Subsystem Impacts

5.3.6.5.1. Command and Data Handling

The FF, while berthed to an attached payload location, may use the ISS data interface or its own free-flyer command and data handling system. The usage of the ISS data interface will not exceed the maximum allowable capability of the attached payload location (low data rate: <1 Mbps; high data rate: 43 Mbps).

5.3.6.5.2. Communications and Tracking

The ISS communications subsystem would be used for controlling free-flying spacecraft during proximity and berthing operations.

5.3.6.5.3. Crew Systems

Free-flyer servicing capability will use existing crew systems, such as EVA tools.

5.3.6.5.4. Environmental Control and Life Support Systems

No impact.

5.3.6.5.5. Guidance, Navigation, and Control

No impact.

5.3.6.5.6. Power

The FF, while berthed to an attached payload location, may use ISS power if its own power generating capability is reduced or disabled (e.g., solar arrays retracted). This usage will not exceed the maximum allowable capability of the attached payload location (113 V dc at 3 kW).

5.3.6.5.7. Propulsion

The FF's serviced at the ISS will require a propulsion system to maneuver from operational orbit to ISS orbit. Minimal impact to the ISS propulsion system is anticipated during rendezvous and proximity operations for ISS attitude adjustments.

5.3.6.5.8. Robotics

The SSRMS would be used to berth the FF to an ISS-attached payload location and also to release it. The ISS crew would also use the SSRMS to exchange payloads, systems, and consumable containers.

5.3.6.5.9. Structures and Mechanisms

Only those FF's that fit within the allowable envelope for attached payloads will be serviceable at the ISS. The FF must also be compatible with ISS interface mechanisms for attached payloads, SSRMS, and special purpose dexterous manipulator (SPDM).

5.3.6.5.10. Thermal Control

No impact.

5.3.7. Bibliography

Gay, Clarence: Attached Payload Interface Requirements Document. International Space Station Program, SSP 57003, NASA Johnson Space Center, Sept. 22, 1999.

Primm, Lowell E., Jr.; and Cook, G.: EXPRESS Pallet System Development Specification. International Space Station Program, SSP 52055, NASA Johnson Space Center, June 29, 1998.

Sampson, Margarita; and Derevenko, Vladimir: Interface Definition Document (IDD) for International Space Station (ISS) Visiting Vehicles (VVs). International Space Station Program Office, SSP 50235, NASA Johnson Space Center, Jan. 25, 1999.

Foreword

This document provides a focused and in-depth look at the opportunities and drivers for the enhancement and evolution of the International Space Station (ISS) during its assembly and until its assembly complete (AC) stage. These enhancements would expand and improve the current baseline capabilities of the ISS and help to facilitate the commercialization of the ISS by the private sector. The intended users of this document include the ISS organization, the research community, other NASA programs and activities, and the commercial sector interested in opportunities that the ISS offers.

The purpose of this document is threefold. First, it provides a broad integrated systems view of the current baseline design of the ISS systems and identifies potential growth and limitations of these systems. Second, it presents current and future options for the application of advanced technologies to these systems and discusses the impacts these enhancements may have on interrelated systems. Third, it provides this information in a consolidated format to research and commercial entities to help generate ideas and options for developing or implementing new technologies to expand the current capabilities of ISS and to assist them in determining potential beneficial uses of the ISS. The content of this document ventures beyond the current designs and capabilities of the ISS towards its future potential as a unique research platform and engineering test bed for advanced technology. It provides an initial source of information to help stimulate the government and private sectors to develop a technological partnership in support of the evolution and commercialization of the ISS.

The ISS Evolution Data Book is composed of two volumes. Volume I contains the baseline design descriptions with section 1 being an introduction to Volume I. Section 2 provides an overview of the major components of the ISS. Section 3 summarizes the ISS baseline configuration and provides a summary of the functions and potential limitations of major systems. Section 4 outlines the utilization and operation of the ISS and furnishes facility descriptions, resource time-lines and margins, and a logistics and visiting vehicle traffic model. Volume II contains information on future technologies, infrastructure enhancements, and future utilization options and opportunities. Section 1 is an introduction to Volume II. Section 2 identifies the advanced technologies being studied by the Preplanned Program Improvement (P³I) Working Group for use on ISS to enhance the operation of the station. Section 3 covers the commercialization of the ISS, and section 4 provides information on the enhancement technologies that go beyond the efforts of the P³I Working Group. Section 5 summarizes the analysis performed for several design reference missions (DRM's) that are being considered for post-AC utilization and enhancements. Section 6 provides utilization opportunities that may enhance the efforts of the human exploration and development of space (HEDS) missions.

The contents of this document were gathered by the Spacecraft and Sensors Branch, Aerospace Systems, Concepts and Analysis Competency, Langley Research Center (LaRC), National Aeronautics and Space Administration (NASA). This document will be updated as the current configuration of the ISS evolves into its AC state and beyond. Much of the baseline configuration description is derived from the International Space Station Familiarization Document, TD9702A, ISS FAM C 21109, NASA Johnson Space Center, July 1998.

Contents

Foreword	iii
Acronyms and Abbreviations	ix
1. Introduction	1-1
2. Advanced Technologies and Utilization Opportunities	2-1
2.1. P ³ I Technologies	2-1
2.1.1. Program Activities and Process	2-1
2.1.1.1. Near-Term Examples	2-2
2.1.1.2. Long-Term Examples	2-4
2.1.1.3. Future Technologies	2-5
2.1.2. P ³ I Road Maps	2-5
3. ISS Commercialization Activities	3-1
3.1. ISS Commercial Development Plan	3-3
3.1.1. Overview	3-3
3.1.2. Bibliography	3-6
3.2. OWI for Registration and Disposition Process for ISS Entrepreneurial Offers	3-7
3.2.1. Overview	3-7
3.2.2. Bibliography	3-10
3.3. Commercial Opportunities	3-11
3.3.1. Communications	3-12
3.3.2. Pharmaceuticals	3-13
3.3.3. Space Manufacturing	3-15
3.3.4. Entertainment and Tourism	3-17
3.3.5. Bibliography	3-18
4. ISS Enhancement Technologies	4-1
4.1. Flywheel Energy Storage for ISS	4-3
4.1.1. Introduction	4-3
4.1.2. Flywheel Energy Storage for the ISS	4-3
4.1.2.1. Flywheel Energy Storage Concept	4-4
4.1.2.2. Storing Energy More Efficiency	4-5
4.1.2.3. Usable Specific Energy Comparison	4-6
4.1.2.4. Improvements in Attitude Control	4-6
4.2. Bibliography	4-7
5. Design Reference Missions for ISS Evolution	5-1
5.1. Introduction	5-1
5.2. Implementation of Energy Storage Enhancement as a P ³ I Technology	5-3
5.2.1. Description	5-3
5.2.2. ISS Enhancement Goal	5-3
5.2.3. Enhancement Specifications	5-3
5.2.3.1. Physical Description	5-3
5.2.3.2. Functional Description and Assumptions	5-3
5.2.4. Interface Requirements	5-4
5.2.5. Enhanced ISS Configuration Description	5-4
5.2.6. ISS Impacts	5-4
5.2.6.1. Installation	5-4
5.2.6.2. Vehicle Configuration	5-5

- 5.2.6.3. Operations 5-5
- 5.2.6.4. Utilization 5-5
- 5.2.6.5. ISS Subsystem Impacts 5-6
- 5.3. ISS Free-Flyer Satellite Servicing 5-7
 - 5.3.1. Description 5-7
 - 5.3.2. ISS Enhancement Goal 5-7
 - 5.3.3. Enhancement Specifications 5-7
 - 5.3.3.1. Physical Description 5-7
 - 5.3.3.2. Functional Description and Assumptions 5-8
 - 5.3.4. Interface Requirements 5-9
 - 5.3.5. Enhanced ISS Configuration Description 5-10
 - 5.3.6. ISS Impacts 5-10
 - 5.3.6.1. Installation 5-10
 - 5.3.6.2. Vehicle Configuration 5-10
 - 5.3.6.3. Operations 5-10
 - 5.3.6.4. Utilization 5-11
 - 5.3.6.5. ISS Subsystem Impacts 5-11
 - 5.3.7. Bibliography 5-13
- 5.4. ISS Advanced Communications Tower 5-15
 - 5.4.1. Description 5-15
 - 5.4.2. ISS Enhancement Goal 5-15
 - 5.4.3. Enhancement Specifications 5-16
 - 5.4.3.1. Physical Description 5-16
 - 5.4.3.2. Functional Description and Assumptions 5-17
 - 5.4.4. Interface Requirements 5-19
 - 5.4.5. Enhance ISS Configuration Description 5-19
 - 5.4.5.1. Communications Coverage 5-19
 - 5.4.6. ISS Impacts 5-23
 - 5.4.6.1. Installation 5-23
 - 5.4.6.2. Vehicle Configuration 5-23
 - 5.4.6.3. Operations 5-24
 - 5.4.6.4. Utilization 5-24
 - 5.4.6.5. ISS Subsystem Impacts 5-25
 - 5.4.6.6. Concluding Remarks 5-26
 - 5.4.7. Bibliography 5-27
- 5.5. TransHab on ISS 5-29
 - 5.5.1. Description 5-29
 - 5.5.2. ISS Enhancement Goal 5-29
 - 5.5.3. Enhancement Specifications 5-29
 - 5.5.3.1. Physical Description 5-29
 - 5.5.3.2. Functional Description and Assumptions 5-32
 - 5.5.4. Interface Requirements 5-32
 - 5.5.5. Enhanced ISS Configuration 5-32
 - 5.5.6. ISS Impacts 5-32
 - 5.5.6.1. Installation 5-32
 - 5.5.6.2. Vehicle Configuration 5-34
 - 5.5.6.3. Operations 5-34
 - 5.5.6.4. Utilization 5-34
 - 5.5.6.5. ISS Subsystem Impacts 5-35

5.6. Reusable Launch Vehicle Transportation Support for ISS	5-37
5.6.1. Description	5-37
5.6.2. ISS Enhancement Goal	5-37
5.6.3. Enhancement Specifications	5-38
5.6.3.1. Physical Description	5-38
5.6.3.2. Functional Description and Assumptions	5-40
5.6.4. External and Internal Interfaces	5-42
5.6.4.1. General Interface Requirements	5-42
5.6.4.2. U.S. On-Orbit Segment Interface Requirements	5-43
5.6.5. Enhanced ISS Configuration	5-43
5.6.6. ISS Impacts	5-44
5.6.6.1. Installation	5-44
5.6.6.2. Vehicle Configuration	5-44
5.6.6.3. Operations	5-46
5.6.6.4. Utilization	5-50
5.6.6.5. ISS Subsystem Impacts	5-50
5.6.6.6. Bibliography	5-54
5.7. Rapid Delivery of Logistics to ISS (Launch Express)	5-57
5.7.1. Description	5-57
5.7.2. ISS Enhancement Goal	5-57
5.7.3. Enhancement Specifications	5-57
5.7.3.1. Physical Description	5-57
5.7.3.2. Functional Description and Assumptions	5-57
5.7.4. Interface Requirements	5-58
5.7.5. Enhanced ISS Configuration Description	5-58
5.7.6. ISS Impacts	5-58
5.7.6.1. Installation	5-58
5.7.6.2. Vehicle Configuration	5-58
5.7.6.3. Operations	5-59
5.7.6.4. Utilization	5-59
5.7.6.5. ISS Subsystem Impacts	5-59
5.7.7. Bibliography	5-60
6. Human Exploration and Development of Space	6-1
6.1. Overview	6-1
6.1.1. Questions to Address	6-1
6.1.2. Goals	6-1
6.1.3. Strategies and Outcomes	6-1
6.1.4. HEDS Road Map	6-2
6.1.5. Bibliography	6-2
6.2. Synergistic Applications of ISS for HEDS Exploration Missions	6-7
6.2.1. Introduction	6-7
6.2.2. Assumptions	6-8
6.2.3. Space Transportation	6-8
6.2.3.1. Affordable Earth-to-Orbit Transportation	6-8
6.2.3.2. Advanced Interplanetary Propulsion	6-9
6.2.3.3. In-situ Resource Utilization and Cryogenic Fluid Management	6-9
6.2.4. Information and Automation	6-9
6.2.4.1. Communications and Networks	6-9
6.2.4.2. Intelligent Systems and Advanced Operations	6-9

6.2.4.3. Intelligent Synthesis Environments	6-10
6.2.5. Sensors and Instruments	6-11
6.2.5.1. Science and Engineering Field Laboratories	6-11
6.2.5.2. Environmental and Medical Monitoring	6-11
6.2.5.3. Sample Curation	6-11
6.2.6. Advanced Space Power	6-12
6.2.6.1. Advanced Power Generation	6-12
6.2.6.2. Energy Storage	6-12
6.2.6.3. Power Management	6-13
6.2.7. Human Support	6-13
6.2.7.1. Flight Crew Systems Issues and Concerns	6-14
6.2.7.2. Advanced Habitation Systems	6-19
6.2.8. Bibliography	6-20

Acronyms and Abbreviations

AAA	avionics air assembly
ABC	audio bus coupler
AC	assembly complete
AD	audio dosimeter
ACBSP	assembly complete baseband signal processor
Acc	accessory
ACESE	attitude control and energy storage experiment
ACRFG	assembly complete radio frequency group
ACRV	advanced crew return vehicle
ACS	assembly contingency subsystem
ACS	attitude control system
ACS	atmosphere control and supply
ACT	advanced communications tower
ACU	arm computer unit
ADAM	Able deployable articulated mast
AERCam	autonomous EVA robotic camera
AES	air evaporation system
AFDIR	automated fault detection, isolation, and recovery
AFR	anchor foot restraint
AFRL	Air Force Research Laboratory
AL	airlock
ALSP	advanced life support pack
AMP	ambulatory medical pack
AMS	alpha magnetic spectrometer
ANR	active noise reduction
AP	attached payload
APAS	androgynous peripheral attachment system
APDS	autonomous peripheral docking system
APFR	articulating portable foot restraint
APM	attached pressurized module
APS	automated payload switch
AR	atmosphere revitalization
ARCU	American to Russian converter unit
ARIS	active rack isolation system
ASCR	assured safe crew return
ASI	Italian Space Agency (Agenzia Spaziale Italiana)
ATCS	active thermal control system
ATM	asynchronous transmission mode
ATU	audio terminal unit
ATV	automated transfer vehicle
AUAI	assembly-contingency/UHF audio interface
avg	average
AVF	artificial vision function
AVU	artificial vision unit
AVU CCD	artificial vision unit cursor control device
AZ	azimuth

Revision A, October 2000

BCDU	battery charge–discharge unit
BCTA	bias calibration table assembly
BEE	basic end effector
BG	beta gimbal
BGA	beta gimbal assembly
BP/EGG	blood pressure/electrocardiogram
BSP	baseband signal processor
BTF	biotechnology facility
C&C	command and control
C&DH	command and data handling
C&T	communication and tracking
C&TS	communication and tracking system
C&W	caution and warning
CADU	channel access data unit
Cal	calibration
CAM	centrifuge accommodation module
CATO	Communication and Tracking Officer
CBA	common berthing adapter
CBM	common berthing mechanism
CCACS	Center for Commercial Applications of Combustion in Space
CCDB	configuration control database
CCDPI	command, control, and data prime item
CCPK	crew contaminant protection kit
CCTV	closed circuit television
CDM	Commercial Development Manager
CDRA	carbon dioxide removal assembly
CEB	combined electronics box
CETA	crew and equipment translation assembly
CEU	control electronics unit
c.g.	center of gravity
CH	collection hardware
CHeCS	crew health care system
CHIA	cargo-handling interface adapter
CHRS	centralized heat removal system
CID	circuit interrupt device
CIR	combustion integrated rack
CLA	capture latch assembly
CM	Columbus module
CMC	Center for Macromolecular Crystallography
CMG	control moment gyroscope
CMILP	consolidated maintenance inventory logistics planning
CMO	crew medical officer
CMRS	crew medical restraint system
CMS	carbon molecular sieve
CMS	countermeasures system
CNS	central nervous system
COF	Columbus Orbital Facility
comm	communication
cont	continued

COR	communications outage recorder
COUP	consolidated operations and utilization plan
CPPI	crystal preparation prime item
CPRP	Critical Path Road Map Project
CPS	consolidated planning system
CPU	central processing unit
CRPCM	Canadian remote power control module
CRV	crew return vehicle
CSA	Canadian Space Agency
CSA-CP	compound specific analyzer–combustion products
CSA-H	compound specific analyzer–hydrazine
CSC	Commercial Space Centers
CSVS	Canadian space vision system
CTB	cargo transfer bag
CTM	crew transportation module
CU	control unit
CVIU	common video interface unit
CWC	collapsible waste container
DA	Deutsche Aerospace
DAC	design analysis cycle
DAIU	docked audio interface unit
D&C	display and control
DC	docking compartment
dc	direct current
DCC	dry cargo carrier
DCPCG	dynamically controlled protein crystal growth
DCSU	direct-current switching unit
DDCU	direct-current-to-direct-current converter unit
DECAT	Dynamic Engineering Communications Analysis Testbed
DES	data encryption standard
dev	develop or development
DLR	German Space Agency (Deutschen Zentrum für Luft- und Raumfahrt)
DOD	depth of discharge
DO45	Flight Planning and Pointing Group
DPO	attitude control thruster
DPU	data processing unit
DRM	design reference mission
DSM	docking and stowage module
EACP	EMU audio control panel
EACP	EVA audio control panel
EAS	early ammonia servicer
EATCS	external active thermal control system
ECCS	expendable charcoal catalyst system
ECLS	environmental control and life support
ECLSS	environmental control and life support system
ECOMM	early communication
ECS	early communication subsystem

Revision A, October 2000

ECU	electronics control unit
EDO	extended duration orbiter
EDV	electronic depressurizing valve
EE	electronics enclosure
EEATCS	early external active thermal control system
EEL	emergency egress light
EETCS	early external thermal control system
EEU	equipment exchange unit
EF	exposed facility
EFA	engineering feasibility assessment
EFGF	electrical flight grapple fixture
EFPL	exposed facility payload
EFU	exposed facility unit
EHS	environmental health system
EIA	experiment integration agreement
EL	elevation
ELM	experiment logistics module
ELM-ES	experiment logistics module-exposed section
ELM-PS	experiment logistics module-pressurized section
ELS	environmental life support
EM	experiment module
EMMI	EVA man-machine interface
EMU	extravehicular mobility unit
EPCE	electrical power-consuming equipment
EPS	electrical power system
ERA	European robotic arm
ER&T	engineering research and technology
ES	exposed section
ESA	European Space Agency
ESP	external stowage platform
est	estimated
ETCS	external thermal control system
ETOV	Earth-to-orbit vehicle
ETSD	external tool stowage device
ETVCG	external television camera group
EUE	experiment unique equipment
EVA	extravehicular activity
EVAS	extravehicular attachment structure
EV-CPDS	extravehicular-charged particle directional spectrometer
EVR	extravehicular robotics
EVSU	external video switch unit
ExMU	EXPRESS memory unit
ExP	EXPRESS pallet
ExPA	EXPRESS pallet adapter
ExPCA	EXPRESS pallet control assembly
EXPRESS	expediting the processing of experiments to Space Station
ExPS	EXPRESS pallet system
ExSD	EXPRESS stowage drawer
FAR	Federal Acquisitions Requirements

4BMS	four-bed molecular sieve
FCF	fluids and combustion facility
FCMS	fluid crystal management system
FCS	flight crew system
FDIR	fault detection, isolation, and recovery
FDPA	flight dynamics planning and analysis
FDS	fire detection and suppression
FESS	flywheel energy storage system
FF	free flyer
FGB	functional cargo block
FIR	fluids integrated rack
FLEX	control of flexible construction systems
flex	flexible
F-O	fiber-optic
FOV	field of view
FRCB	Flight Rule Control Board
FRCS	forward reaction control system
FSE	flight support equipment
<i>g</i>	gravity or gravitational unit
GASMAP	gas analysis system for metabolic analysis of physiology
GBF	gravitational biology facility
GCR	galactic cosmic radiation
GFE	government furnished equipment
GFI	ground fault interrupter
GLONASS	global navigation satellite system
GN&C	guidance, navigation, and control
govt	government
GPS	global positioning system
GR&C	generic groundrules, requirements, and constraints
GRC	NASA John H. Glenn Research Center at Lewis Field
GUI	graphical user interface
Hab	habitation module
HCMG3X	momentum H of CMG3 in <i>x</i> direction
HCMG3Y	momentum H of CMG3 in <i>y</i> direction
HCMG3Z	momentum H of CMG3 in <i>z</i> direction
HD	highly directable
HDPCG	high-density protein crystal growth
HDR	high data rate
HDTV	high-definition television
HEDS	Human Exploration and Development of Space
HGA	high gain antenna
HIRAP	high-resolution accelerometer package
HLV	heavy lift vehicle
HMC	hydrogen master clock
HMI	human machine interface
HMS	health maintenance system
HPGA	high pressure gas assembly

Revision A, October 2000

HRDL	high rate data link
HRF	human research facility
HRFM	high rate frame multiplexer
HRM	high rate modem
HTL	high-temperature loop
HTV	H-2 transfer vehicle
I	increment
I_{sp}	specific impulse
IAA	intravehicular antenna assembly
IAC	internal audio controller
IAS	internal audio subsystem
ICC	integrated cargo carrier
ICD	instrument control document
ICK	insert contaminant kit
ICM	interim control module
ICU	interim control unit
ID	identification
IDA	integrated diode assembly
IDD	interface definition document
IDRP	increment definitions requirements plan
IEA	integrated equipment assembly
IEPT	International Execution Planning Team
IF	intermediate frequency
I/F	interface
IFHX	interface heat exchanger
IFM	in-flight maintenance
IIDP	increment implementation data pack
IMARS	ISS mission operations directorate avionics reconfiguration system
IMAX	maximum image
IMCA	integrated motor controller assembly
IMMI	IVA man-machine interface
IMS	inventory management system
Int	international
INPE	National Institute for Space Research—Brazil (Instituto Nacional de Pesquisas Espaciais)
I/O	input/output
IOCU	input/output controller unit
IOP	integrated operations plan
IP	International Partners
IPACS	integrated power and attitude control systems
IPS	integrated planning system
IR	infrared
ISIS	international subrack interface standard
ISPR	international standard payload rack
ISS	International Space Station
ISSA	International Space Station assembly
ISSP	International Space Station Program
ITA	integrated truss assembly
ITCS	internal thermal control system

ITS	integrated truss structure
IVA	intravehicular activity
IV-CPDS	intravehicular-charged particle directional spectrometer
IVSU	internal video switch unit
JEM	Japanese experiment module
JEM RMS	JEM remote manipulator system
JEU	joint electronics unit
JOP	joint operations plan
JSC	NASA Lyndon B. Johnson Space Center
KhSC	Khrunichev Space Center
KSC	NASA John F. Kennedy Space Center
Ku-band	Ku-band subsystem
KuRS	Ku radar system
L	launch
Lab	laboratory module
LAN	local area network
LaRC	NASA Langley Research Center
LCA	loop crossover assembly
LCA	Lab cradle assembly
LDA	launch deploy assembly
LDCR	long-duration crew restraint
LDFR	long-duration foot restraint
LDM	logistics double module
LDR	low data rate
LDU	linear drive unit
LEE	latching end effector
LEO	low Earth orbit
LGA	low gain antenna
LOS	loss of signal
LRDL	low rate data link
LSG	life sciences glove box
LSS	life support system
LT	laptop
LTL	low-temperature loop
LTU	load transfer unit
LVLH	local-vertical–local-horizontal
MA	main arm
maint	maintenance
MAMS	microgravity acceleration measurement system
MAS	microbial air sampler
MATE	multiplexer/demultiplexer application test equipment
MBF	mission build facility
MBS	mobile remote servicer base system

Revision A, October 2000

MBSU	main bus switching unit
MCAS	MBS common attachment system
MCC	Mission Control Center
MCC—H	Mission Control Center—Houston
MCC—M	Mission Control Center—Moscow
MCHL	master component heat load
MCS	motion control system
MCU	MBS computer unit
MCV	Medical College of Virginia
MDL	middeck locker
MDM	multiplexer-demultiplexer
MEC	medical equipment computer
MECO	main engine cutoff
MELFI	minus eighty degree laboratory freezer for ISS
MEO	medium Earth orbit
MESA	miniature electrostatic accelerometer
MF	multifiltration
MFU	multifiltration unit
MHI	Mitsubishi Heavy Industries, Ltd.
MIM	multi-increment manifest
MIMO	multiple-input–multiple-output
min	minimum
MIP	mission integration plan
MITAC	Medical Informatics and Technology Application Center
MITP	multilateral increment training plan
MLE	middeck locker equivalent
MLI	multilayer insulation
MMCC	metal monolith catalytic converter
MMH	monomethyl hydrazine
MM/OD	micrometeoroid/orbital debris
MOD	mission operation directorate
MPLM	multipurpose logistics module
MPV	manual procedure viewer
MRD	Microgravity Research Division
MRDL	medium rate data link
MSC	mobile servicing center
MSD	mass storage device
MSFC	NASA George C. Marshall Space Flight Center
MSG	microgravity science glove box
MSL	materials science laboratory
MSRF	materials science research facility
MSRR	materials science research rack
MSS	mobile servicing system
MT	mobile transporter
MTCL	MT capture latch
MTL	moderate-temperate loop
MTSAS	module truss structures attachment system
N/A	not applicable
NASA	National Aeronautics and Space Administration

NASDA	National Space Development Agency of Japan
NC	nozzle closed
NGO	nongovernment organization
NIA	nitrogen interface assembly
NO	nozzle open
NPCC	nonpressurized cargo carrier
NRA	NASA Research Announcement
NRL	Naval Research Laboratory
NTA	nitrogen tank assembly
OARE	orbital acceleration research experiment
OCA	orbiter communications adapter
OCCS	onboard complex control system
ODF	operations data file
ODS	orbiter docking system
OE/V	OSTP editor/viewer
OFA	operations feasibility assessment
OFTS	orbital flight targeting system
OMS	orbital maneuvering system
OOCI	OSTP/ODF crew interface
OOS	on-orbit operations summary
OPS	operations
OPS LAN	onboard operations local area network
ORU	orbital replacement unit
OSE	on-orbit support equipment
OSTP	onboard short-term plan
OTCM	ORU tool changeout mechanism
OTD	ORU transfer device
OWI	Operational Work Instruction
P&S	pointing and support
P ³ I	Preplanned Program Improvement
PAA	phased array antenna
PAO	Public Affairs Office
PAS	payload attachment system
PBA	portable breathing apparatus
PBS	Public Broadcasting Service
PCAP	payload crew activity plan
PCBA	portable clinical blood analyzer
PCC	pressurized cargo carrier
PCG	protein crystal growth
PCS	portable computer system
PCU	plasma contactor unit
PD	payload developer
PDA	power distribution assembly
PDAC	procedures development and control
PDGF	power and data grapple fixture
PDR	preliminary design review
PEHB	payload Ethernet hub/bridge

PEHG	payload Ethernet hub gateway
PFC	pump and flow control
PFCS	pump and flow control subassembly
PFE	portable fire extinguisher
PFM	pulse frequency modulation
PG	Product Groups
PHP	passive hearing protection
PI	prime investigation
PIA	payload integration agreement
PIA	port inboard aft
PIF	port inboard forward
PIM	Payload Integration Manager
PIMS	principal investigator microgravity services
PIP	payload integration plan
PIU	payload interface unit
PL	payload
PLSS	personal life support system
PM	pressurized module
PM	propulsion module
PMA	pressurized mating adapter
PMAD	power management and distribution
POA	payload/ORU accommodation
POA	port outboard aft
POCB	Payload Operations Control Board
PODF	payload operations data file
POF	port outboard forward
POIC	payload operations integration center
POIF	payload operations and integration function
POP	payload operations plan
PP	planning period
PPA	pump package assembly
prelim	preliminary
PRLA	payload retention latch actuators
prox	proximity
PS	pressurized section
PSD	power spectral density
PTCS	passive thermal control system
PTU	pan-tilt unit
PU	panel unit
PUL	portable utility light
PV	photovoltaic
PVA	photovoltaic array
PVCU	photovoltaic control unit
PVM	photovoltaic module
PVR	photovoltaic radiator
PVT	pressure-volume-temperature
PVTCS	photovoltaic thermal control system
PWP	portable work platform
QD	quick disconnect

R/A	return air
R&D	research and development
RAIU	Russian audio interface unit
RAM	random access memory
RAM	radiation area monitor
RBI	remote bus isolator
RCS	reaction control system
R/D	receiver/demodulator
ref	reference
RF	radio frequency
R/F	refrigerator/freezer
RFP	request for proposal
RGA	rate gyro assembly
RHC	rotational hand controller
RHX	regenerative heat exchanger
RIC	rack interface controller
RIS	remote triaxial sensor
RLV	reusable launch vehicle
RLVCC	RLV Control Center
RM	research module
RMS	remote manipulator system
ROEU	remotely operable electrical umbilical
ROS	Russian Orbital Segment
RPC	remote power controller
RPCM	remote power controller module
RPDA	remote power distribution assembly
RPF	robotics planning facility
rpm	revolutions per minute
R-S	receive-send
RSA	Russian Aviation and Space Agency
RSC-E	Rocket Space Corporation-Energia
RSP	respiratory support pack
RSP	resupply stowage platform
RSR	resupply stowage rack
RSS	reusable space system
RSU	roller suspension unit
RTAS	Boeing/Rocketdyne truss attachment system
RTS	remote triaxial sensor
RUPSM	resource utilization planning and system models
RVCO	RVE closeout
RVE	rack volume equivalent
RWS	robotics workstation
SA	Spar Aerospace
SAFER	simplified aid for EVA rescue
SAGE	strategic aerosol and gas experiment
SAMS	space acceleration measurement system
SAM-II	second-generation space acceleration measurement system
SAREX	Shuttle amateur radio experiment
SARJ	solar alpha rotary joint

Revision A, October 2000

SAW	solar array wing
S-band	S-band subsystem
SCU	sync and control unit
SDFR	short-duration foot restraint
SE	sensor enclosure
SFA	small fine arm
SFCA	system flow control assembly
SGANT	antenna group
SIA	starboard inboard aft
SIF	starboard inboard forward
SIR	standard interface rack
SKD	orbit correction engine
SLP	Spacelab pallet
SM	service module
SMMOD	service module micrometeoroid and orbital debris shield
SOA	starboard outboard aft
SOC	state of charge
SODF	systems operations data file
SOF	starboard outboard forward
SPDA	secondary power distribution assembly
SPDG	Space Product Development Group
SPDM	special purpose dexterous manipulator
spec	specification
SPG	single point ground
SPP	science power platform
SPV	single-pressure vessel
SRMS	Shuttle remote manipulator system
SRTM	Shuttle radar topography mission
SS	Space Shuttle
SSAS	segment-to-segment attachment system
SSBRP	Space Station Biological Research Project
SSC	Station support computer
SSCB	Space Station Control Board
SSCS	space-to-space communication system
SSK	surface sampler kit
SSP	Space Shuttle Program
SSPCM	solid-state power control module
SSRMS	Space Station remote manipulator system
SSSR	space-to-Space-Station radio
SSU	sequential shunt unit
STP	short-term plan
STS	Space Transportation System
SVS	space vision system
S/W	software
T	takeoff or time
TBD	to be determined
TBS	to be supplied
TCCS	trace contaminate control subassembly
TCP/IP	transmission control protocol/internet protocol

TCS	thermal control system
TD	transfer device
TDRS	tracking and data relay satellite
TDRSS	tracking and data relay satellite system
TEA	torque equilibrium attitude
TEF	thermal electric freezer
TEPC	tissue equivalent proportional counter
TH	TransHab
THC	temperature and humidity control
THC	translational hand controller
TM	transport spacecraft, modified
TPA	tissue plasminogen activator
TRC	transmitter/receiver/controller
TRL	technology readiness level
TRRJ	thermal radiator rotary joint
TSC	Telescience Support Center
TSH	triaxial sensor heads
TUS	trailing umbilical system
TWMV	three-way mix valve
UAB CBSE	University of Alabama at Birmingham Center for Biological Sciences and Engineering
UCC	unpressurized cargo carrier
UCCAS	unpressurized cargo carrier attachment system
UCS	ultrahigh frequency communication system
UDM	universal docking module
UF	utilization flight
UHF	ultrahigh frequency
ULC	unpressurized logistics carrier
ULCAS	upper ULC attachment system
UMA	umbilical mechanism assembly
UOP	utility outlet panel
UP	urine processor
U.S.	United States
USAF	United States Air Force
USFS	U.S. Flywheel Systems, Inc.
USOS	U.S. on-orbit segment
UTA	utility transfer assembly
VASIMAR	variable specific impulse magnetoplasma rocket
VAX	virtual architecture extendable
VBSP	video baseband signal processor
VCD	vapor compression distillation
VCMS	video commanding and measuring system
VDS	video distribution system
verif	verification
VES	vacuum exhaust system
VOA	volatile organic analyzer
VRA	volatile removal assembly

Revision A, October 2000

VS	vacuum system
VSR	vacuum resource system
VSU	video switch unit
VTR	video tape recorder
WIF	worksite interfaces
WM	waste management
WMK	water microbiology kit
WORF	window observational research facility
WRM	water recovery and management
W/S	workstation
WSGS	White Sands Ground Station
WSS	workstation stanchions
WV	work volume
WWW	Worldwide Web
X,Y,Z	axes
XCF	X-ray crystallography facility
XDPI	X-ray diffraction prime item
XPNDR	standard TDRSS transponder
XPOP	X-axis perpendicular to orbit plane
ZEM	Z1 experiment module
ZOE	zone of exclusion
ZSR	zero-g stowage rack.
ϕ_x, θ_y, ψ_z	polar coordinates

5.4. ISS Advanced Communications Tower

5.4.1. Description

The ISS ACT is an advanced communications concept comprised of locating sets of Ka-band PAA's on top an ≈ 70 -ft deployable mast structure, which was originally studied to be attached to the top of the centrifuge accommodation module (CAM). (See fig. 5.4-1.) Although this location is no longer feasible, the results of this study are being presented for insight into the ACT concept. Additional sights are being studied and the results will be presented in future revisions of this document. The ACT will provide advanced communications capabilities for ISS payloads desiring dedicated high return link data rates and near continuous coverage with either advanced TDRSS satellites (H, I, and J) or a commercial telecommunications satellite constellation network. Information from the documents listed in the bibliography (section 5.4.7) was used to compile this section.

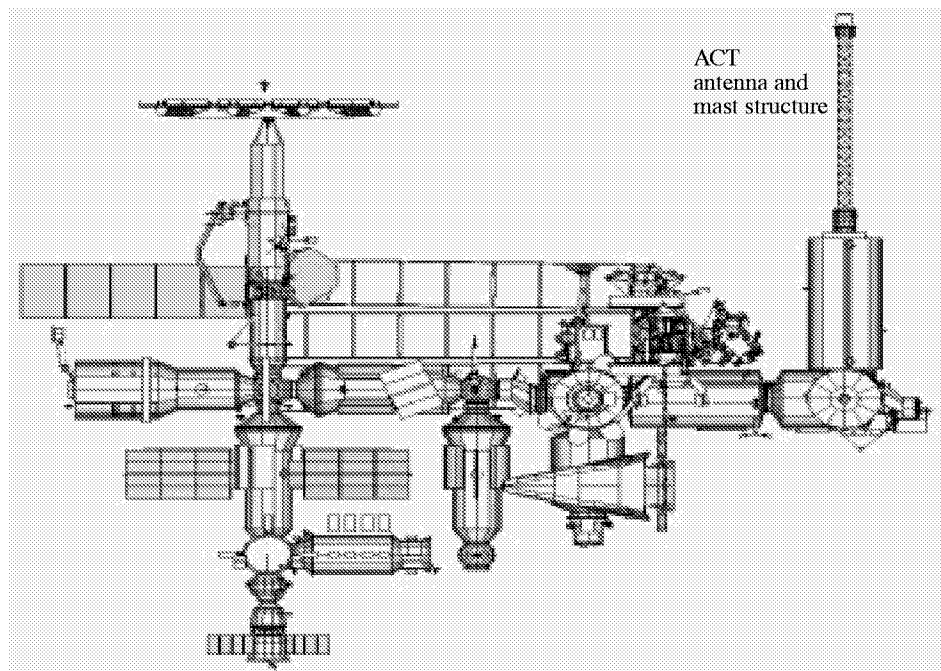

Figure 5.4-1. ACT on top of CAM.

5.4.2. ISS Enhancement Goal

The goal of the ACT is to provide nearly 100 percent of communications coverage with either the advanced TDRSS network (TDRSS H, I, and J) of communications satellites, or a commercial telecommunications satellite network (e.g., Celestri and Teledesic).

In response to an anticipated need by the payload community for a dedicated real-time return link of experiment data, ACT will provide the payload community with a higher bandwidth dedicated connection of telemetry data capability (>100 Mbps) to facilitate experiments. Taking advantage of newer technologies in the communications industry, ACT will provide a platform to allow communications with generations of communications satellites. Initially, incorporating ACT will require modifications or additions to the design of the CAM to include provisions (scars) to mount to the tower; support power, data, and control bus (1553) operations with the PAA's; and to provide a high bandwidth data interface connection to ISS payloads. Some early

provisions for ISS resources (power and data buses) and software additions must also be targeted in the preliminary arrangement to accommodate the ACT.

5.4.3. Enhancement Specifications

5.4.3.1. Physical Description

5.4.3.1.1. Self-Deployment Mast Structure

The ACT tower section is comprised of an ≈70-ft self-deployable articulated mast (manufactured by AEC-Able Engineering Company, Inc.) that is attached to the top of the CAM. Once the ACT is maneuvered and attached to the CAM via EVA and robotic arms, the articulated mast self-deploys from the canister to the full extension of ≈70 ft. Table 5.4-1 shows the physical details of the mast. This mast portion of the ACT, defined as the Able deployable articulated mast (ADAM), will extend to greater than 25 times its stowed length. The deployed mast is an internally pre-loaded truss exhibiting near-linear structural behavior and is housed within a canister that is bolted to the CAM. The canister will be a redesign of a previously successful configuration used on a Shuttle mission (Shuttle radar topography mission (SRTM)); thereby, the mass is reduced as required through the removal of unnecessary structure while maintaining full functionality. The primary mechanical interface will be relocated to a single mounting ring. The canister shells, rings, tip plate, base plate, gussets, brackets, stiffeners, and mounting pads will be deleted or redesigned as required to meet ISS launch loads and interface specifications. (See fig. 6.4-2.)

Table 5.4-1. Physical Details of ISS ACT

Geometry:	
Nominal mast diameter, m (in.)	1.12 (44.123)
Nominal bay width, cm (in.)	79.25 (31.200)
Nominal bay length, cm (in.)	69.75 (27.462)
Number of bays	22
Mast stroke, m (in.)	14.7 (576)
Canister diameter estimate, m (in.)	1.32 (52)
Canister length estimate, m (in.)	2.26 (89)
Mass:	
Mast mass estimate (with utilities), kg (lbm)	160 (352)
Canister mass estimate, kg (lbm)	≤500 (1100)
Stiffness:	
EI, MN-m ² (lbf-in ²)	13 (4.7 × 10 ⁹)
GA, MN (lbf)	0.49 (1.1 × 10 ⁴)
GJ, MN-m ² (lbf-in ²)	0.15 (5.3 × 10 ⁷)
Fixed-free first bending mode, Hz	0.68
Fixed-free first torsion mode, Hz	1.9
Strength:	
Moment strength, M _{cr} , N-M (in-lbf)8140 (72 000)
Shear strength, V _{cr} , N (lbf)	400 (90)
Torsional strength, T _{cr} , N-m (in-lbf)	305 (2700)
Stability:	
Bending stability (rotation) (0.1 N-m), arc sec (deg)	±0.02 (±6.0 × 10 ⁻⁶)
Bending stability (translation) (0.1 N-m), μm (in.)	±2.5 (±0.100)
Torsion stability (0.1 N-m), arc sec (deg)	±4.9 (±0.0014)
Axial stability, μm/N (in/lbf)	±0.4 (±0.75)

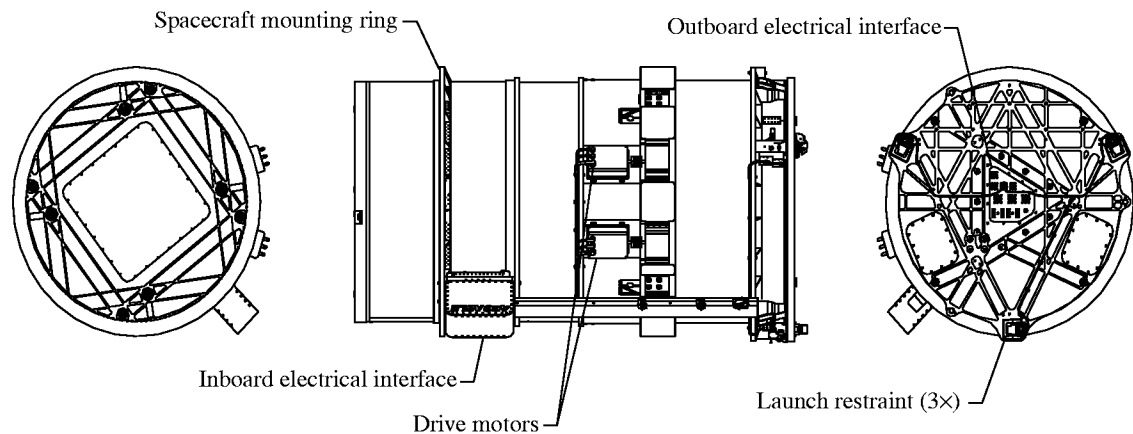

Figure 5.4-2. ACT deployable articulated mast canister.

The launch restraint, stack advance, stack restraint, root stiffness, and deployment systems will be essentially the same as SRTM. In addition, the ACT canister will be approximately 68 cm shorter than the SRTM canister because of the shorter mast stroke (16 m versus 60 m). The ACT mast system is designed to deploy, retract, and redeploy on orbit if required.

Prior to deployment of the mast, the ACT must first be connected to the CAM through a series of bulkhead connectors to connect power, control, and data interfaces to the inside of the CAM; then it is physically bolted to the CAM using 16 0.5-in. bolts. EVA is expected to be utilized along with the Shuttle's robotic arm for ACT removal from the Shuttle bay and placement onto the CAM. When guy wires are used, four additional connections are made to mount these cables or wires to the structure of the CAM for support.

5.4.3.1.2. Phased Array Antenna Complex

This antenna configuration, which utilizes multiple PAA's for maximum coverage to the communications satellites, will be configured to provide $>\pm 120^\circ$ coverage (nonoptimized) about the elevation axis and $\pm 70^\circ$ about the azimuth axis. Each PAA will be a multielement (>512) array of transmission and receive elements designed onto a platform complete with electronics, power, and data interfaces. (See fig. 5.4-3.) Each antenna will be multiplexed and combined with the others to complete the PAA complex. A combined electronics box (CEB) will be used for controlling the antenna array functions, multiplexing the antenna signals together, coordinating data and commands sent from and to the ISS interfaces, and providing the proper signal format to communicate with the satellites.

5.4.3.2. Functional Description and Assumptions

Before the ACT mast begins to self-deploy, the PAA assembly must be placed onto the mast mounting structure, and all interface connections must be completed. At the fully deployed range, the PAA complex will be >70 ft above the ISS truss structure. Through control electronics and software, these PAA's will be electronically steered to maintain optimum pointing to the communications satellites. When one of the antennas is close to being out of the coverage range to a particular communications satellite, a switchover to another antenna will occur (if possible) to continue communications coverage with that satellite. Similarly, if a communications satellite is

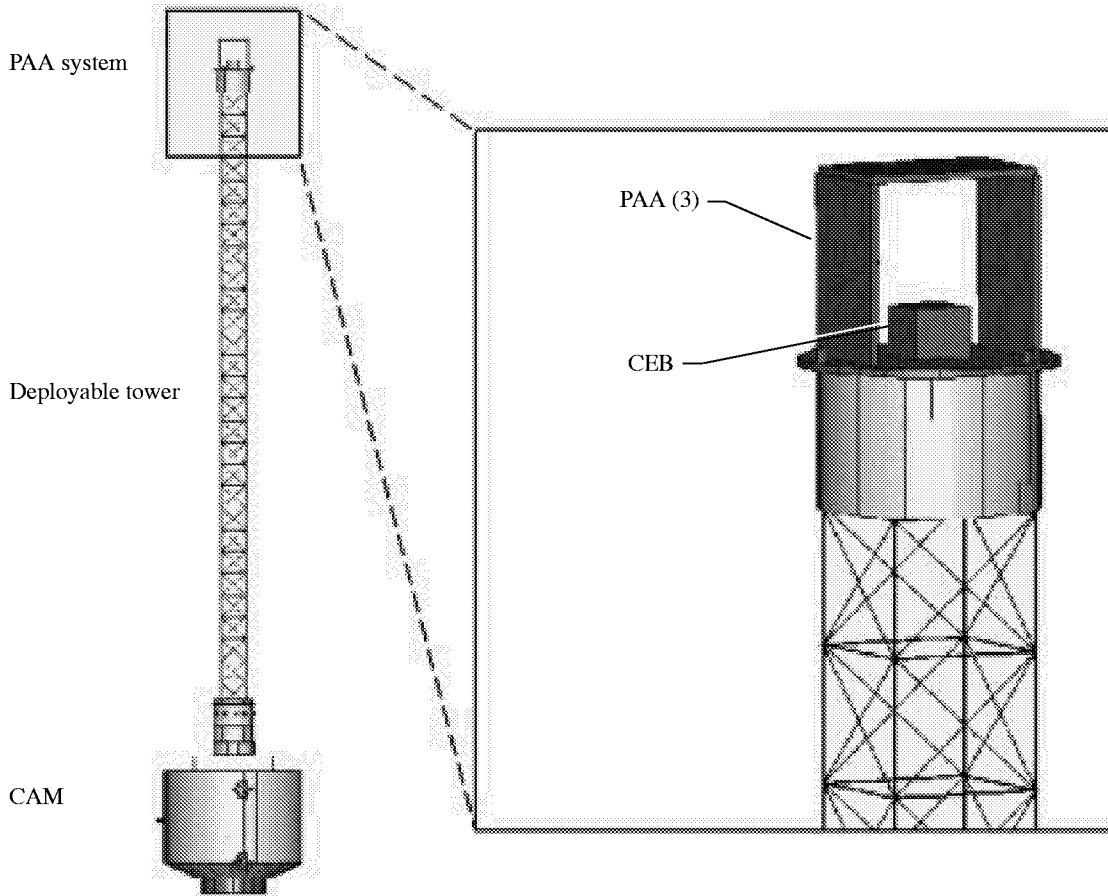

Figure 5.4-3. Phased array antenna complex.

about to go out of range, a switchover to another selection may be necessary to pick up coverage to another satellite.

Connections to the payload high rate data link (HRDL) and automated payload switch (APS) interfaces exist through connections within the CAM to provide the capability for payloads to send data to the ACT PAA complex for data return to Earth. Payload software (via payload MDM) will be responsible for coordinating and controlling the data rates. Control bus connections (via 1553) are available to the PAA complex to allow for the control and status of the system.

The assumptions are as follows:

- The ACT will be configured, deployed, and utilized after ISS AC
- The CAM design can be modified to include scars that will accommodate the ACT at a later date
- The ISS has sufficient power reserve at AC to meet the needs of the ACT
- The payload MDM will provide command, control, and coordination of status with the PAA assembly

- The CAM has sufficient resources and interface connections to meet the needs of the ACT
- The command and control (C&C) MDM and/or payload MDM software will include the capability to initialize pointing control of the PAA steerable beams and will contain information regarding satellite locations

5.4.4. Interface Requirements

The ACT requires external interface connections to occur right at the CAM zenith end cap bulkhead plate. These interface connections will be responsible for providing power to the PAA's, for providing a 1553 data interface between the PAA's and control software located within ISS (payload MDM), and for providing fiber-optic data lines for both forward and return data link paths. There may also be four attachment points on the CAM to accommodate guy wires for the tower structure when it is fully deployed.

The CAM will need to provide the following internal interfaces with the ISS to accommodate the ACT:

- Provide a switched connection to the ISS power bus
- Provide a 1553 interface connection that has an active path back to the C&C MDM and the payload MDM
- Provide a fiber-optic interface with the payload HRDL system for a return link path
- Provide an interface to accept forward link data sent by the ground center and transfer these data to payload MDM and/or C&C MDM.

5.4.5. Enhance ISS Configuration Description

As discussed in section 5.4.1, ACT will provide a platform of state-of-the-art-technology communications which can be used to provide near continuous coverage to either the advanced TDRSS satellite network (H, I, and J), or to a particular commercial telecommunications satellite constellation network. The study to include ACT is based upon an AC configuration of the ISS, with attempts to identify those design changes to ISS hardware and software that would be necessary for ACT to succeed. At most, the CAM will need most of the design additions to accommodate the tower structure and the PAA network and to interface with ISS power, control, and data buses. Internal connections to the HRDL and APS may need some rerouting to provide the payload connectivity with the ACT link, and some system software will need modifications or additions for controlling the PAA's and configuring the connections to the satellites.

5.4.5.1. Communications Coverage

The ACT will improve the coverage of return data from the ISS. As designed, the ISS initially will provide Ku-band return rates of 50 Mbps (43.2 Mbps true data) at AC. Expected enhancements to reach 150 Mbps are planned. Table 5.4-2 shows the estimated TDRSS coverage of Ku-band communications by assembly flights; the best coverage is about 72 to 86 percent to a three-satellite TDRSS network. Software "keep-out" zones will further degrade the coverage available, maybe as much as another 10 to 15 percent. These keep-out zones are necessary to avoid radiation contamination of EVA astronauts and certain modules or systems. The ACT will

Table 5.4-2. Typical TDRSS Coverage for ISS Ku-Band by Flights

[Analysis data taken from JSC–Lockheed Martin communications coverage study performed on a DAC 5 model of the ISS with zero beta angle on the solar arrays and an LVLH attitude mode]

Ku-band coverage by flight	Two TDRS coverage, percent	Two TDRS coverage with Shuttle, percent	Three TDRS coverage, percent	Three TDRS coverage with Shuttle, percent
7A	51.1	46.5	TBD	TBD
12A	36.5	35.2	TBD	TBD
16A	70.0	61.7	TBD	TBD

provide an enhanced communications coverage approaching 100 percent when utilized with either advanced TDRSS (H, I, and J) or a commercial telecommunications satellite network.

5.4.5.1.1. Nonoptimized coverage

Although a multiplexed combination of three PAA steerable beamwidths could conceivably provide $\pm 160^\circ$ of electronically steerable coverage in the elevation (EL) direction (fig. 5.4-4), the analysis was performed with an elevation range of only -120° to $+120^\circ$. By selecting this range, most of the ISS structure was outside the radiating zone of the ACT. This range provides a keep-out zone that is even larger than the planned ISS gimbal “masking” approach. To truly optimize the coverage analyses, the elevation range could be increased to enhance coverage to the satellites.

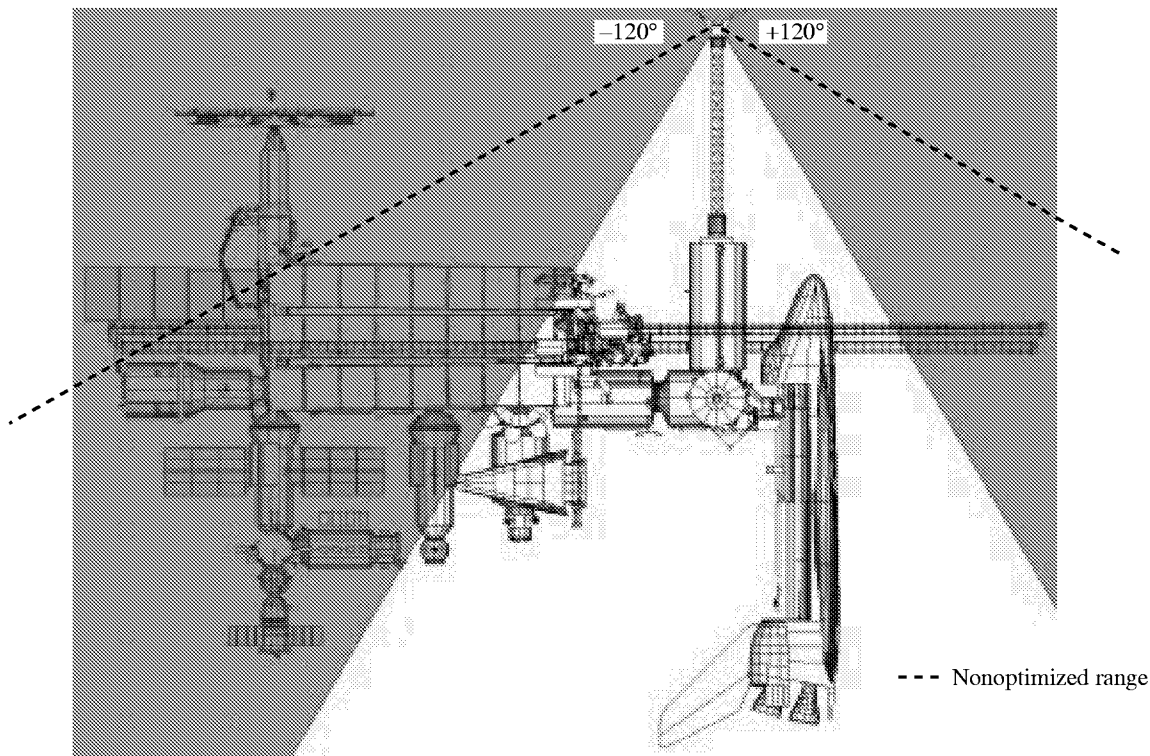

Figure 5.4-4. Elevation coverage range for all three antennas.

Based on selection and design criteria of the PAA complex (for purposes of saving mass and power), it is feasible to reach maximum coverage of 100 percent continuously. Tables 5.4-3 and 5.4-4 provide calculated coverage to both these networks, based upon a 1- to 3-day analysis after AC. Analyses were performed with the Dynamic Engineering Communications Analysis Testbed (DECAT) software, which is widely used by the ISS Program Engineering Analysis Group at JSC. Use of DECAT software was selected based upon a proven and reliable communications analysis capability at JSC to assess comparisons of the ACT coverage against current TDRSS coverage estimates with the same analysis tools. This assessment will help validate the coverage predictions while using the same ISS model (DAC 6) to perform calculations.

Table 5.4-3. ACT Coverage to TDRSS (H, I, and J) at AC

Analysis	TDRS H coverage, percent (a)	TDRS I coverage, percent (a)	TDRS J coverage, percent (a)	Total theoretical coverage, percent (a)	Total coverage for full PAA AZ, percent (b)	Total coverage for degraded PAA AZ, percent (c)
Day 1	43.75	44.75	44.0	100	98	87
Day 2	43.4	45.6	44.1	100	98	87
Day 3	44.1	43.8	43.9	100	98	88
Day 4	43.9	44.2	44.2	100	98	88

^aTotal coverage calculated based on theoretical capability provides more than hemispherical coverage to ACT PAA's to show that if given this coverage at this tower location, 100 percent communications can be achieved; however, because PAA's at best can give $\pm 70^\circ$ in AZ steerable range, compare this coverage with "real" capability analyses.

^bUtilization of full PAA AZ steerable range is realized; EL range is nonoptimized.

^cUtilization of a slightly degraded PAA AZ steerable range is utilized to show the drop-off in coverage; EL range is nonoptimized.

Note: in *a*, *b*, and *c*, a make-before break strategy is employed concerning communications with the TDRS.

Table 5.4-4. ACT Coverage to Commercial Telecommunications Network at AC

[Simulated Celestri/Teledesic partial constellation]

Plane	Satellite	Conditional coverage, ^a percent	Plane	Satellite	Conditional coverage, ^a percent
1	1-3	7.64	1	4-6	7.50
2	1-3	6.25	2	4-6	6.67
3	1-3	6.25	3	4-6	5.83
4	1-3	6.94	4	4-6	7.08
5	1-3	8.61	5	4-6	9.03
6	1-3	9.44	6	4-6	9.10
7	1-3	7.08	7	4-6	7.92
8	1-3	6.39	8	4-6	5.97
9	1-3	6.25	9	4-6	5.28
10	1-3	6.81	10	4-6	6.53

^aAZ = -70° to $+70^\circ$; EL = -120° to $+120^\circ$.

5.4.5.1.2. Analysis Assumptions

Loss of signal (LOS) coverage to each TDRS assuming PAA conditional coverage plus assuming H, I, and J are colocated where original TDRS satellites are located (41°W, 171°W, and 275°W longitudes, respectively). The following assumptions are made:

1. Proper handoff from one TDRS to another is accomplished; theoretical PAA antenna range used is $-90^\circ < AZ < 90^\circ$ and $-130^\circ < EL < 130^\circ$, where zenith direction is 0° EL and the velocity vector direction is 0° AZ
2. Proper handoff from one TDRS to another is accomplished; PAA antenna range is $-70^\circ < AZ < 70^\circ$ and $-130^\circ < EL < 130^\circ$, where zenith direction is 0° EL and the velocity vector direction is 0° AZ
3. Proper handoff from one TDRS to another is accomplished; PAA antenna range is $-60^\circ < AZ < 60^\circ$ and $-130^\circ < EL < 130^\circ$, where zenith direction is 0° EL and the velocity vector is 0° AZ

5.4.5.1.3. Constellation Assumptions

The assumptions for the constellation are as follows:

- Analysis conducted with 72 satellites, 6 each equally spaced in 12 different planes
 - Epoch date of January 1, 2003; simulation time of 1 day
 - Near circular orbit; altitude of 1400 km; 90° inclination
 - 30° plane spacing between ascending node longitudes
 - In-plane satellites separated by 60° (argument of perigee)
 - Each plane shifts argument of perigee for each satellite by 15° to provide a spread coverage similar to a typical network
 - Utilized satellite data for Celestri, specifically parameters for altitude, antennas, frequency, etc.
- Conditional coverage assumes the following PAA look angles from zenith boresight (EL = 0°):
 - Azimuth range from -70° to $+70^\circ$
 - Elevation range from -120° to $+120^\circ$

5.4.6. ISS Impacts

5.4.6.1. Installation

The ACT will be assembled on top of the CAM on orbit using EVA and robotic arms. First, the mast structure will be connected and placed on top of the CAM, followed by placement of the PAA platform on top of the mast prior to deployment. In both cases, hooking up bulkhead interface connections before final assembly on orbit will be necessary. Figure 5.4-5 shows a representative view of the mast. Further kinematic, obstruction, and reach analyses need to be done to show that the Shuttle remote manipulator system (RMS) can reach the top of the CAM to place the ACT canister and PAA complex.

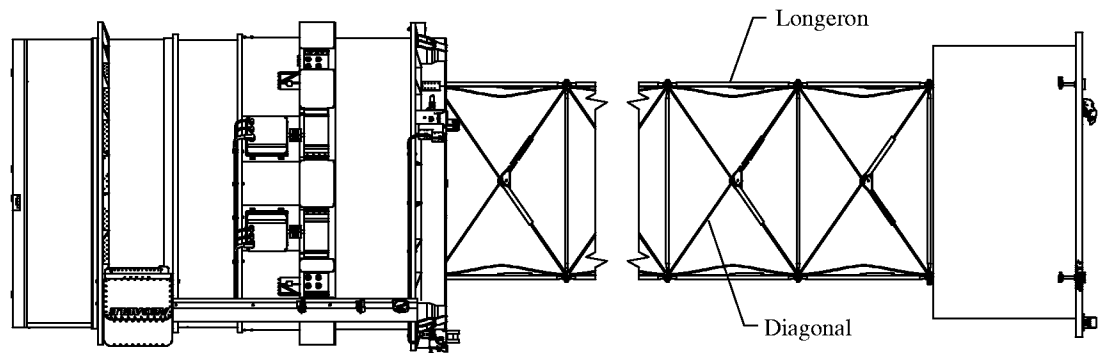

Figure 5.4-5. Tower canister and deployed mast.

5.4.6.2. Vehicle Configuration

5.4.6.2.1. Mass Properties

The deployable articulated mast and canister will have a mass of approximately 600 kg. (See table 5.4-1.) The PAA platform will have a mass of approximately 200 kg. The power, control, and data interface cables will have a mass of approximately 60 kg.

5.4.6.2.2. Flight Attitude

A slight shift in ISS attitude may occur because of the addition of the ACT and its structural and mass properties. Additional studies will have to be conducted to verify that no major changes occur.

5.4.6.2.3. Control

A slight change in ISS control may occur because of the addition of the ACT and its structural and mass properties. Additional studies will have to be conducted to verify that no major changes occur here.

5.4.6.2.4. Orbital Lifetime

The same effects should be studied as presented in sections 5.4.6.2.2 and 5.4.6.2.3.

5.4.6.3. Operations

5.4.6.3.1. Intravehicular Activity

IVA may be needed to connect interface cables from inside the CAM to the top bulkhead connectors.

5.4.6.3.2. Extravehicular Activity

EVA will be required for mounting both the mast structure (nondeployed) and the PAA complex platform on top of the CAM, as well as connecting the interface bulkhead connections with the cables.

5.4.6.3.3. Ground Support Operations

TBD

5.4.6.3.4. Visiting Vehicle Operations

The impact of visiting vehicles must be studied to determine the structural loads and excitation modes during vehicle docking and berthing. Currently this study has not been performed.

5.4.6.4. Utilization

5.4.6.4.1. Microgravity

TBD

5.4.6.4.2. Payload Accommodations

Further investigations and studies may reveal that the ACT can accommodate other mounted instruments such as cameras, small stellar-looking payloads, material exposure structures, and structural characterization experiments. However, additional or new communications links might be necessary if the interfaces do not exist.

5.4.6.4.3. Payload Operations

Modifications most likely will be required to the Payload MDM software to facilitate control of sending payload data to the ACT data interface, as well as potential changes to payload ground control software and monitoring. Matters to consider carefully are control of the payloads with the new forward link capability of the ACT and how command data encryption and control would actually occur.

5.4.6.5. ISS Subsystem Impacts

5.4.6.5.1. Command and Data Handling

The command and data handling (C&DH) subsystem may require modification of the payload MDM software, as well as the addition of pointing control software to steer the beams of the PAA's during orbit.

5.4.6.5.2. Communications and Tracking

Enhanced communications reaching near 100 percent coverage to either the advanced TDRSS network or a particular commercial telecommunications satellite constellation can be achieved. ACT will provide the payload community with ≈ 143 Mbps of return link bandwidth, and a potential of >1.5 Mbps of forward link communications. Investigations of the effect of additional blockage to the existing S-band and Ku-band systems need to be made because of the addition of the ACT. Some additional blockage may be expected to occur, but if the ACT provides much greater data transfer capability, maybe the existing Ku-band system can be used as a backup.

Because the ACT has electronically steerable PAA's, software will have to maintain a list of known satellite locations (in the case of TDRSS H, I, and J or commercial satellite networks) to properly steer the antenna beams during orbit.

5.4.6.5.3. Crew Systems

See the descriptions in sections 5.4.6.3.1 and 5.4.6.3.2.

5.4.6.5.4. Environmental Control and Life Support Systems

No impact.

5.4.6.5.5. Guidance, Navigation, and Control

If the ACT is used to communicate with commercial telecommunications satellites (non-NASA satellites), it may be necessary for the guidance, navigation, and control (GN&C) system to receive a data set of satellite locations, but at present this does not seem to be necessary. The "locations" of such satellites should exist within any software that may affect operations of the communications system.

5.4.6.5.6. Power

The ISS power subsystem will need to provide reserve power to the ACT and PAA platform. Power range may be from 575 to 1725 W.

5.4.6.5.7. Propulsion

At present the ACT has no effects on the ISS propulsion system, but the tower could possibly be used to augment roll control of the ISS by adding ORU thruster pods to the structure. A detailed study will have to take place to verify this capability.

5.4.6.5.8. Robotics

The SSRMS may be needed to remove the ACT assembly and PAA platform from the bay of the delivering vehicle.

5.4.6.5.9. Structures and Mechanisms

A redesign of the CAM zenith plate will be necessary to include bulkhead connections for ACT power, payload data, and control bus interfaces. The zenith side of the CAM must incorporate changes to add mounting hardware for the ACT structure, as well as a potential use of guy wires to stabilize the deployed configuration.

5.4.6.5.10. Thermal Control

TBD

5.4.6.6. Concluding Remarks

The ACT design approach and conditional analyses show that near-continuous communications coverage can occur by adding a deployable tower and state-of-the-art PAA's on top of the CAM. Table 5.4-3 indicates an increase in coverage to TDRSS (H, I, and J) above what is already planned by the current ISS communications systems strategy at AC. Further, by utilizing access to a constellation¹ of commercial telecommunications satellites, it is conceivably possible to achieve near 100 percent coverage for a capable data return link from the ISS to any number of ground stations. Utilization of a commercial satellite constellation allows for the telemetry data for payload experiments to be "addressed" to reach a particular ground segment. The need to bring data to a focal point (i.e., WSGS in the case of TDRSS) before routing may no longer be necessary. True desktop computer access by individual PI's to their experiments in real time may be achievable.

Further analyses and design implementation studies and optimizations are needed to carefully determine the effects to both the current ISS communications capability and the design modifications to the CAM (and ISS (TBD)) that would be necessary to implement the ACT approach.

¹By utilizing characteristics of a Celestri-like telecommunications constellation and by utilizing only 72 of a planned network of 288 satellites or more, table 5.4-4 indicates results from analyses showing coverage of approximately 94 percent. It seems indicative that a fully functional commercial telecommunications constellation, coupled with PAA optimization and operational planning, could provide payloads with full-time, real-time access to experimental data at data bandwidths greater than 100 Mbps.

5.4.7. Bibliography

- Anon.: ADAM Concept for the ISS Advanced Communications Tower (ACT). AEC-Able Engineering Co., Inc., July 22, 1998.
- Anon.: NASA/NASDA Joint Specification for the Centrifuge Accommodation Module. International Space Station Program—SRR Release, SSP 50312, NASA Johnson Space Center, Apr. 1998.
- Anon.: Space Station Program Node Element 2 to Centrifuge Module Interface Control Document, Part 1, International Space Station Program. SSP 41147, Pt. 1, Rev. B, NASA Johnson Space Center, Dec. 18, 1998.
- Steel, D. J.; Jarvis, S. L.; and Adkins, A. A.: DECAT User's Guide—Release 4.0. Sub Task Order EV-C05, Lockheed Martin Engineering & Sciences, Apr. 1996.
- Tran, T. T.; and deSilva, B. K.: Design Analysis Cycle 5 S and KU Band Coverage Assessment Data Package. Sub Task Order HECEV4P2, Lockheed Martin Space Missions & Services, May 30, 1997.

5.5. TransHab on ISS

5.5.1. Description

TransHab (TH) has been proposed as a transportation vehicle habitat for the Mars mission. The TH will be an inflatable, pressurized structure that will serve as the crew living and working quarters during the mission. This module has been proposed to add pressurized volume to the ISS.

5.5.2. ISS Enhancement Goal

The goal of using the TH is to provide additional volume for crew and research facilities. The TH could also be used as a reentry vehicle for the return of crew, products, and/or wastes from Station activities. An aerobrake and heatshield will have to be added to the TH to facilitate its use as a reentry vehicle.

5.5.3. Enhancement Specifications

5.5.3.1. Physical Description

The TH is composed of two main elements—the shell and the core as shown in figures 5.5-1 through 5.5-4. The shell is a laminate of air bladders, structural webbing, thermal insulation, and impact shielding. The core contains the main structures, avionics, and ECLSS components. The TH is 27 ft in diameter and 40 ft in total length when fully inflated.

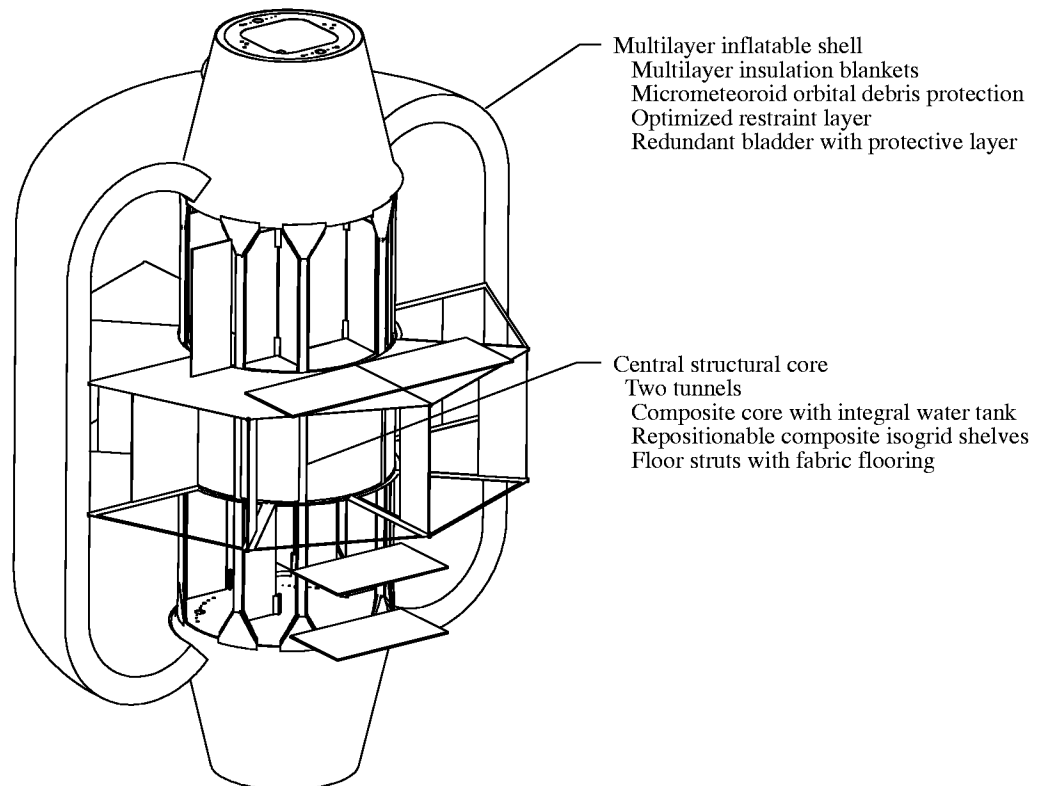

Figure 5.5-1. TransHab features.

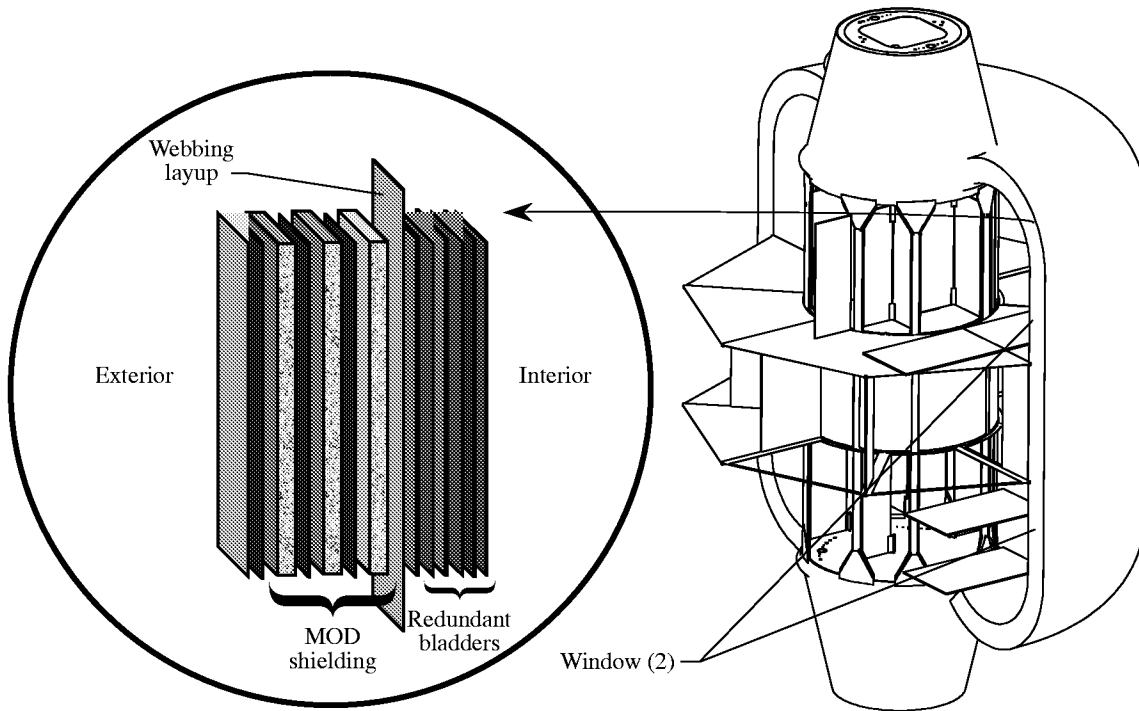

Figure 5.5-2. TransHab multilayer inflatable shell composition.

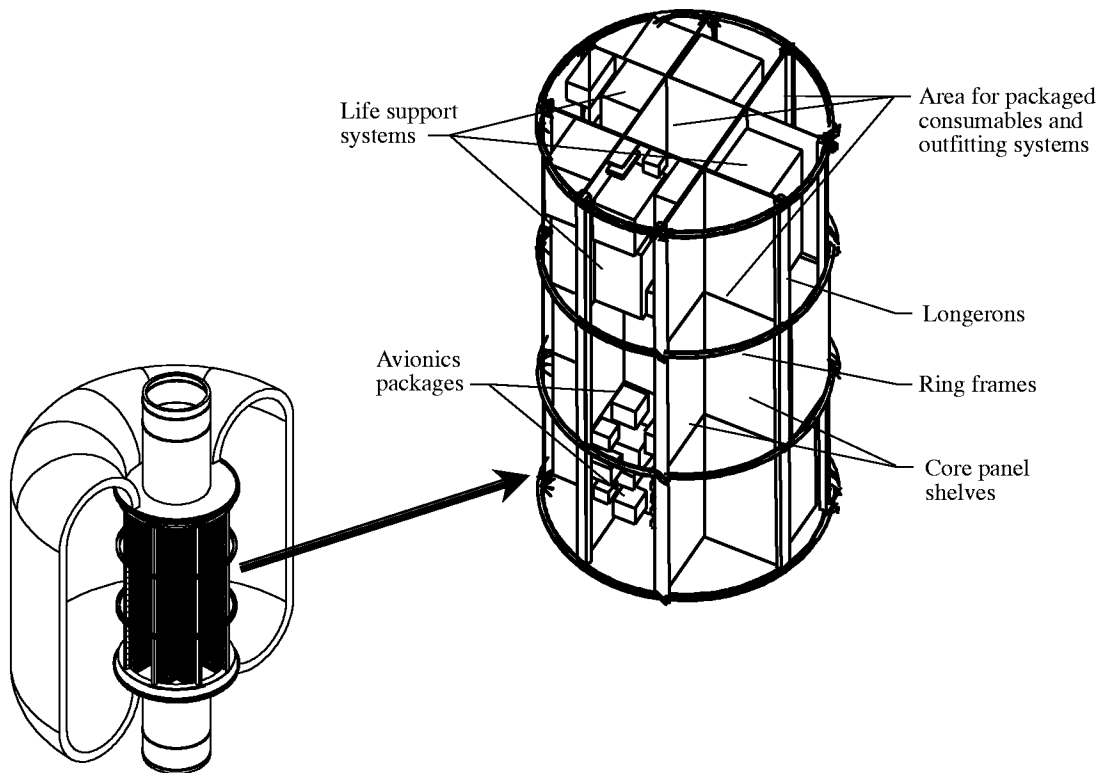

Figure 5.5-3. TransHab core structural layout.

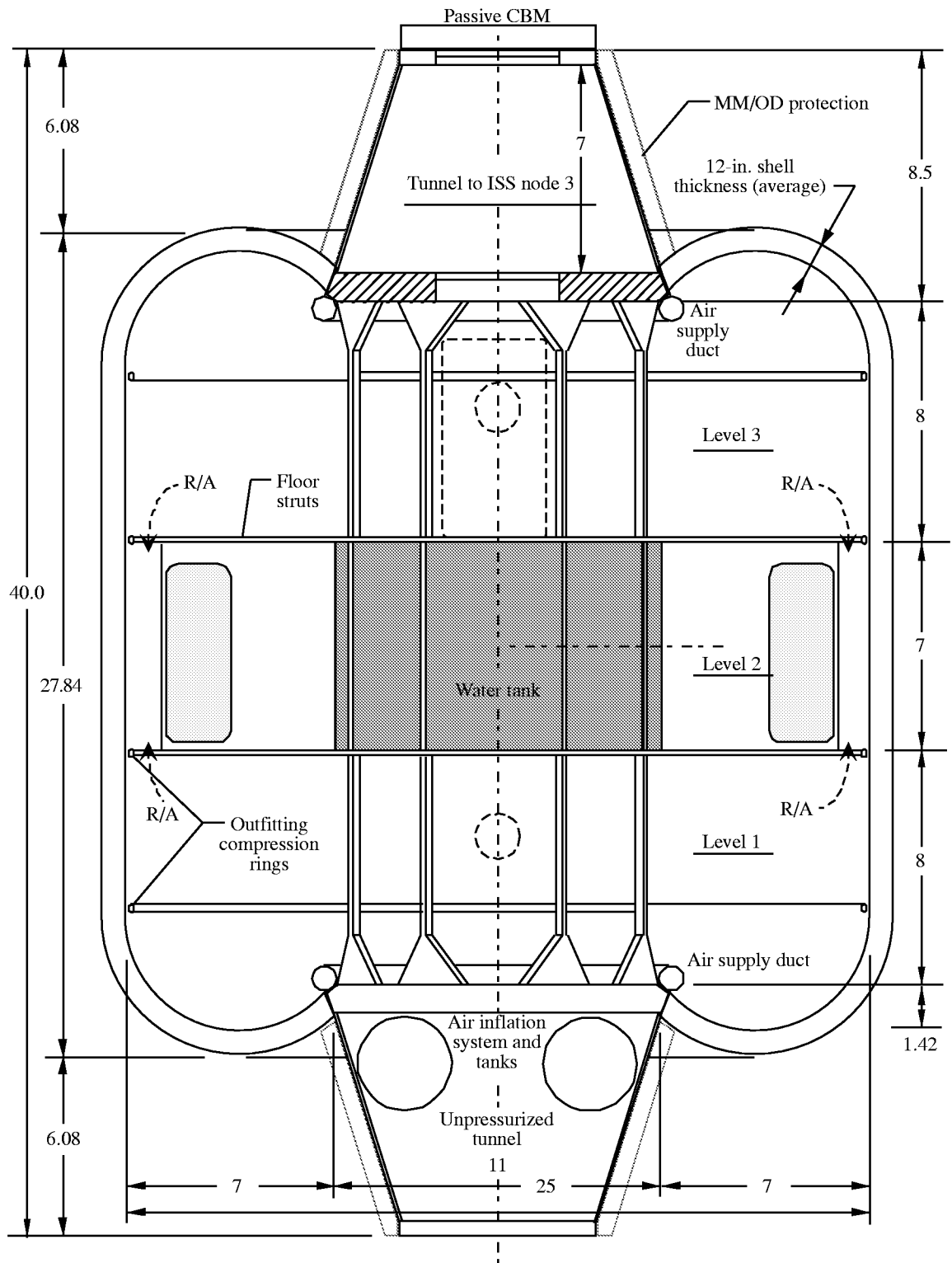

Figure 5.5-4. TransHab cross section. Dimensions are in feet. (Truss sections, radiators, and solar arrays are not shown.)

5.5.3.2. Functional Description and Assumptions

The TH will increase the pressurized volume of the ISS for living space and microgravity experiments. The TH will be delivered to ISS by the Shuttle orbiter. The SSRMS will remove the TH from the orbiter. The common berthing mechanism (CBM) on one end of the core tunnel will dock to an active CBM on a node or module. The ISS crew will inflate and outfit the TH for use. To be used as a reentry vehicle, the TH must be outfitted with an aerobrake. The aerobrake will be assembled and installed at the station.

The assumptions are as follows:

- TH will be added to the baseline AC ISS
- TH will not interfere with transportation vehicle docking, loading or unloading, and departure operations
- TH will not alter the microgravity levels in the laboratory modules beyond the ISS microgravity specifications

5.5.4. Interface Requirements

The TH will be attached to a CBM. Power, thermal, communications, and data connections will be necessary.

5.5.5. Enhanced ISS Configuration

The TH will provide additional volume for crew quarters, laboratory and manufacturing facilities, microgravity, and other facilities. An alternate use of the TH will be as a reentry vehicle for the return of crew, products, and/or wastes from station activities. An aerobrake and heatshield will have to be added to the TH to facilitate its use as a reentry vehicle.

5.5.6. ISS Impacts

5.5.6.1. Installation

The TH will attach to the ISS by using a CBM either at a node port or a module end port. The TH has been proposed as a replacement for the U.S. habitation module (Hab) that is currently in the baseline design to be attached to the port side of node 3. An alternate attachment location for the commercially based TH module could be on the nadir port of node 3. (See figs. 5.5-5 and 5.5-6.) These commercial TH modules would be targeted for research and eventually space-based manufacturing. The number of TH modules and their locations could have significant impacts on the ISS microgravity environment and ISS operations. See sections 5.5.6.3 and 5.5.6.4 for further discussion.

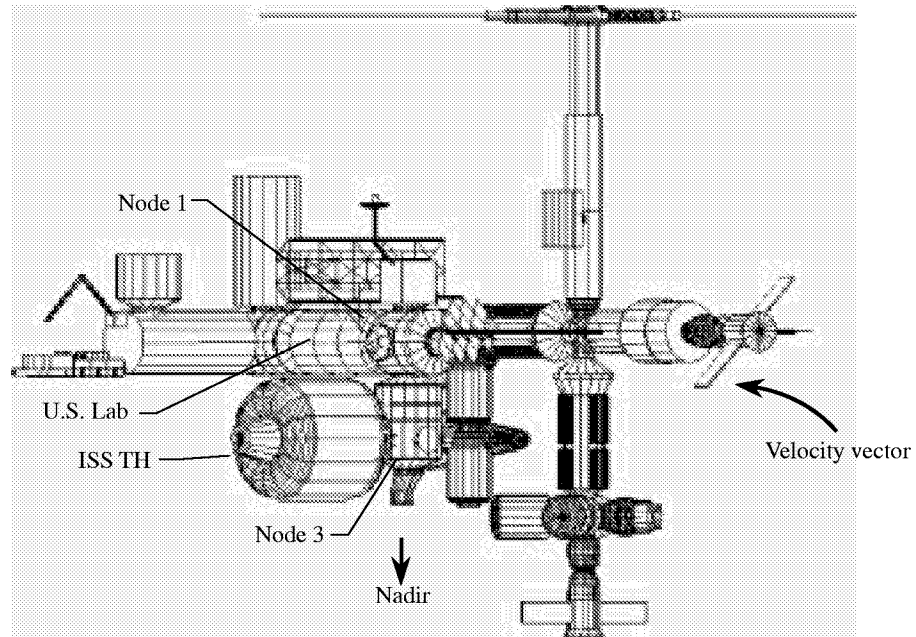

Figure 5.5-5. Proposed ISS accommodation for TransHab on Hab port of node 3. (Truss sections, radiators, and solar arrays are not shown.)

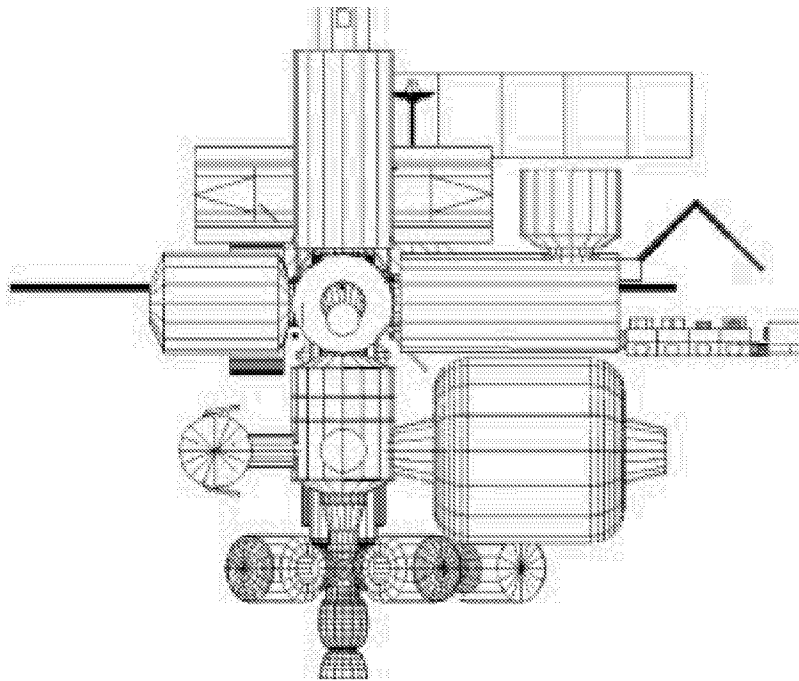

Figure 5.5-6. Forward view of proposed ISS accommodation for TransHab on node 3. (Truss sections, radiators, and solar arrays are not shown.)

5.5.6.2. Vehicle Configuration

5.5.6.2.1. Mass Properties

The TH adds 35600 lb to the total mass of the ISS. Further study is needed to determine the effects of this mass on ISS moments of inertia.

5.5.6.2.2. Flight Attitude

Initial analysis shows that there is minimal impact to the ISS flight attitude in the Hab position. Further study is needed to determine effects of locating the TH in other locations on the ISS.

5.5.6.2.3. Control

Initial analysis shows that there is minimal impact to the ISS control system in the Hab position. Further study is needed to determine effects of locating the TH in other locations on the ISS.

5.5.6.2.4. Orbital Lifetime

TBD

5.5.6.3. Operations

5.5.6.3.1. Intravehicular Activity

The TH will need several weeks of IVA for inflation, setup, and outfitting.

5.5.6.3.2. Extravehicular Activity

The SSRMS will remove the TH from the orbiter and berth the TH to an active CBM.

5.5.6.3.3. Ground Support Operations

TBD

5.5.6.4. Utilization

5.5.6.4.1. Microgravity

Initial analysis shows that there is minimal impact to the ISS microgravity levels with the TH in the Hab position. Further study is needed to determine the effects of berthing the TH in other locations on the ISS.

5.5.6.4.2. Payload Accommodations

Adding the TH to the ISS as a laboratory module will increase the experiment space by TBD racks.

5.5.6.4.3. Payload Operations

TBD

5.5.6.4.4. Visiting Vehicle Operations

Docking simulations and analysis are needed to determine the effects of adding TH to the ISS.

5.5.6.5. ISS Subsystem Impacts

5.5.6.5.1. Command and Data Handling

TH will use the ISS C&DH system. The level of additional load on the system is dependent on the use of the TH; a laboratory TH will require greater use of the C&DH system.

5.5.6.5.2. Communications and Tracking

Additional analysis of the communications needs of the TH must be performed to determine the level of additional capacity necessary.

5.5.6.5.3. Crew Systems

Additional crew support equipment and provisions will be included in the TH. These include restraints and mobility aids, crew operational and personal provisions, portable emergency provisions, lighting, decals and placards, tools and housekeeping supplies. The use of the TH will determine the necessary additional crew systems. As a habitat module the TH will provide additional food systems, crew quarters, and waste collection and personal hygiene facilities. See volume I, section 3.10.3 for descriptions of the crew systems.

5.5.6.5.4. Environmental Control and Life Support Systems

Additional ECLSS equipment will be mounted within the TH. This equipment includes ducting, fans, fire detection and suppression (FDS), and portable breathing apparatus (PBA).

5.5.6.5.5. Guidance, Navigation, and Control

Control analysis of the ISS with the TH berthed must be performed to determine the effect.

5.5.6.5.6. Power

The addition of the TH will increase the demands on the ISS power system. The additional module will draw power for ECLSS, C&DH, and experiments.

5.5.6.5.7. Propulsion

The addition of the TH will increase the projected surface area of the ISS; thereby, the aerodynamic drag on the station will be increased. This drag will create a need for additional reboost capacity and more frequent reboost activities.

5.5.6.5.8. Robotics

TBD

5.5.6.5.9. Structures and Mechanisms

No additional structure will be needed to install the TH in place of the Hab. Analysis is required to verify the need for additional structure to accommodate the TH in other locations. An analysis also needs to be performed to assess the impact of mounting an aerobrake for the reentry mode of the TH.

5.5.6.5.10. Thermal Control

With the addition of added components, additional thermal radiators will be needed. TH reentry vehicles may provide their own radiator surfaces.

5.6. Reusable Launch Vehicle Transportation Support for ISS

5.6.1. Description

NASA and industry are currently studying a number of reusable launch vehicle (RLV) concepts for the eventual replacement of the Space Shuttle. A primary mission for a new RLV will be ISS transportation support including logistics resupply, crew rotation, and delivery of growth or replacement elements including the crew return vehicle (CRV).

In addition to the commercial opportunity to develop a human-related, next-generation RLV, opportunities may exist for the commercial development of associated support equipment and facilities for the RLV–ISS mission. Examples include an RLV crew module to support crew rotation and pressurized and nonpressurized cargo carriers for logistics resupply.

Since no specific RLV concept has been selected for full-scale development, this section addresses ISS system and operations issues and requirements associated with utilization of a generic, Shuttle-class RLV. Vehicle-specific design concepts are considered only to the extent necessary to assess potential ISS system and operations issues. Examples include assessment of RLV performance-to-orbit capability, associated flight rate implications to meet annual ISS logistics resupply and crew rotation requirements, and resulting impacts to the ISS quiescent environment requirement.

Results of a NASA study evaluating crew and cargo carrier options based on the Lockheed Martin VentureStar[®] RLV are presented in this section as a representative example only.

5.6.2. ISS Enhancement Goal

The major goals for a next generation human-rated RLV including requirements to support ISS crew rotation and logistics resupply are summarized as follows:

- Support NASA “Agency Safety Initiative” by

Meeting or exceeding JSC-28354 (Human-Rating Requirements)

Meeting or exceeding RLV program safety requirements for development of crew and cargo carriers

- Maintain on-orbit operations of the ISS by

Rotating 3 ISS crew members every 90 days

Meeting annual pressurized cargo delivery and return requirements

Crew logistics

User logistics

Spares and maintenance logistics

Propellant

Water and gas logistics

- Rotate CRV once every 3 yr
- Maintain 180 days/yr (in no less than 30-day increments) on ISS for microgravity research
- Support NASA goal of reducing cost of delivering and returning crew and cargo to and from low Earth orbit to

Minimize impacts to ISS

Minimize impacts to RLV

Minimize crew module and cargo carrier recurring and nonrecurring costs while meeting safety and ISS operational requirements

5.6.3. Enhancement Specifications

5.6.3.1. Physical Description

The Lockheed Martin VentureStar RLV, a single-stage-to-orbit vehicle, is one example of a Shuttle-class transportation concept currently under study which may some day replace the Space Shuttle. Figure 5.6-1 provides an illustration of this RLV, and a summary of top-level vehicle specifications are given in table 5.6-1.

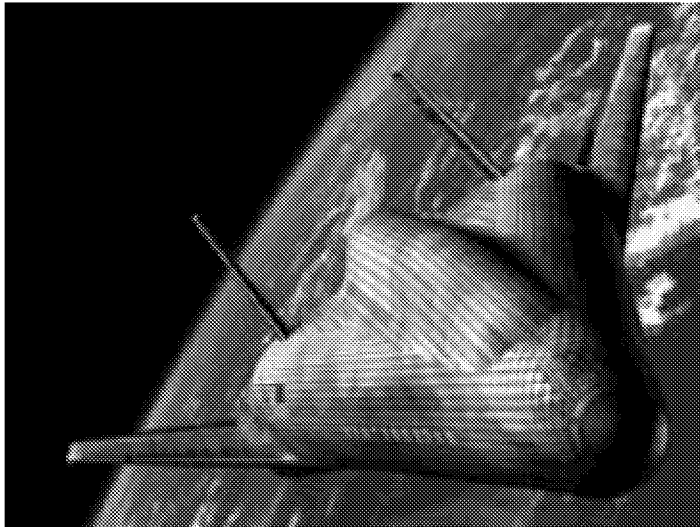

Figure 5.6-1. Lockheed Martin VentureStar RLV reference configuration.

Table 5.6-1. Lockheed Martin VentureStar Vehicle Specifications

Capacity to 248 nmi circular orbit with inclination of 51.6°, lb	25 000
Downmass, lb	+25 000
Size of payload bay, ft.	15 by 53
User resources	
Power, kW	5
Thermal, kW	3.5
Data	Yes
Robotic arm	No

New cargo carriers and carrier configurations may be required for the RLV–ISS mission for many reasons such as

- RLV payload bay may be configured or sized differently than the Shuttle payload bay and may use a difference mechanism for payload attachment
- RLV cargo delivery capability to ISS may be less than Shuttle capability; to minimize potential impact on flight rate (and associated ISS impacts including degraded microgravity research environment), carrier mass fractions may require improvement to maximize net ISS cargo-carrying capability
- New carrier configurations may provide flexibility to manifest a combination of pressurized and nonpressurized cargo on a single RLV flight; ability to manifest mixed cargo provides additional means to optimize RLV performance and may enhance ISS utilization through more timely delivery of research and spares and maintenance cargo
- New carrier configurations may be required to provide payload transport capabilities inherent with the Shuttle; for example, Shuttle middeck lockers, used to transport cargo including ISS research payloads, may not be compatible with RLV crew transportation module because of volume or mass limitations; to accommodate this type of payload which typically has requirements for late/early access, a pressurized cargo carrier configuration with late/early access capability may be needed

An illustration of a pressurized carrier concept developed for the VentureStar RLV utilizing composite materials is shown in figure 5.6-2. A nonpressurized carrier concept for the VentureStar RLV based on advanced materials and advanced structural fabrication techniques is illustrated in figure 5.6-3.

Since the Space Shuttle replacement is envisioned to be a commercial, multipurpose, multi-customer transportation system, RLV concepts generally include an uncrewed configuration for cargo delivery as well as a crewed configuration for transportation of ISS personnel. As such, the RLV configuration for ISS cargo delivery may not include a cockpit, crew systems, or other systems necessary for human flight.

For the purposes of the NASA–Lockheed Martin study, RLV configurations for human transportation utilized a crew transportation module (CTM) to provide life support functions and vehicle monitoring and control functions for the RLV crew. In this configuration, a crew escape

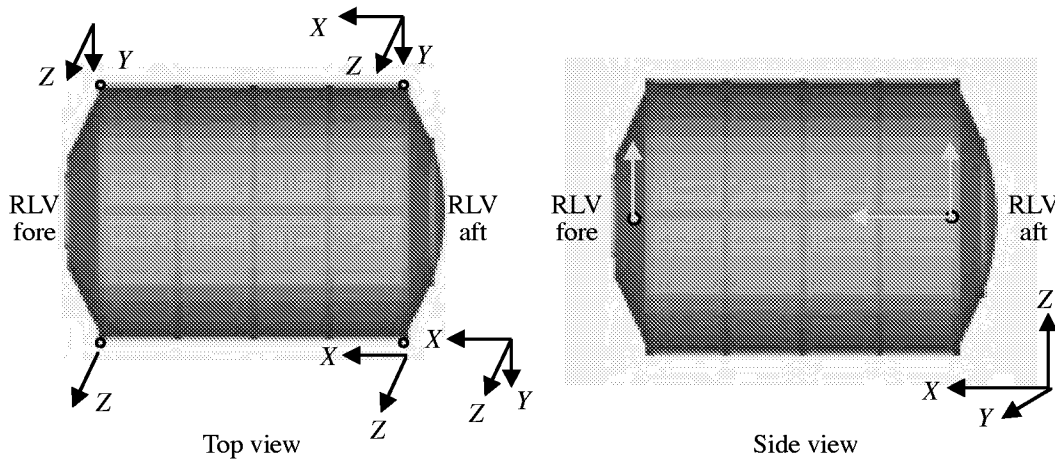

Figure 5.6-2. Composite four-bay, 16-rack pressurized cargo-carrier concept developed for VentureStar RLV.

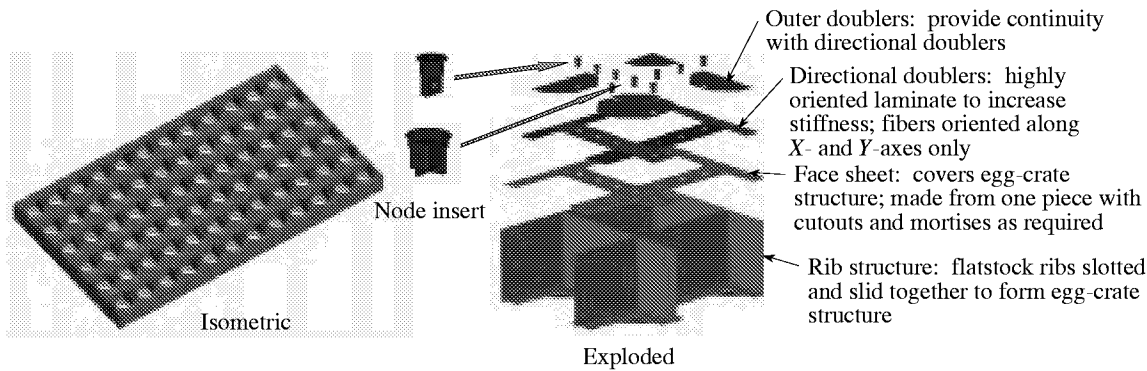

Figure 5.6-3. Isometric and exploded detail views of composite, nonpressurized cargo-carrier concept developed for VentureStar RLV.

capability in the event of catastrophic vehicle failure would be accommodated in certain flight regimes by powered separation of the CTM from the RLV. Figure 5.6-4 illustrates a CTM concept developed for the VentureStar RLV in which the CTM is positioned in the RLV payload bay.

5.6.3.2. Functional Description and Assumptions

The analyses of ISS system and operations issues associated with RLV transportation presented in this section are based on the following assumptions:

- ISS will be fully assembled (AC configuration) and operational prior to the beginning of RLV transportation support
- The generic RLV assumed is a Space Shuttle class vehicle; specific performance-to-orbit capabilities have not been assumed; return capability of RLV is assumed at least equivalent to delivery capability

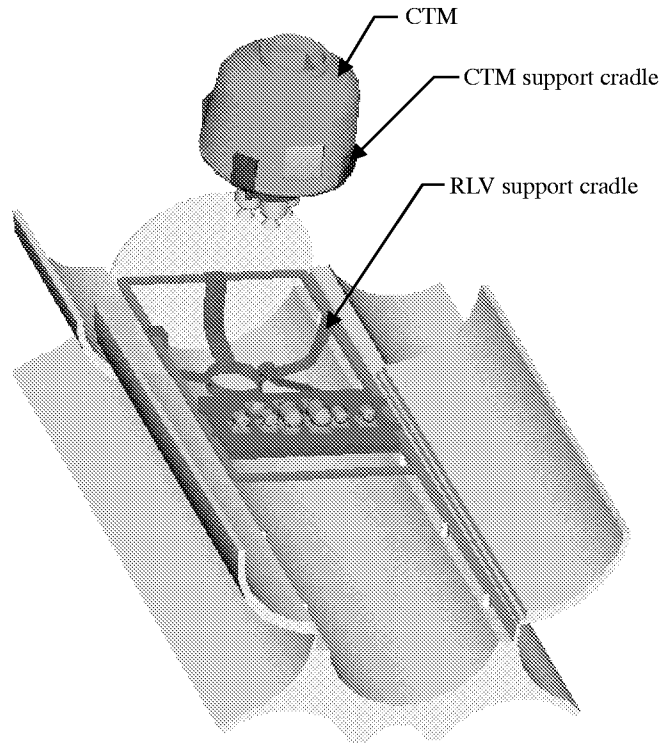

Figure 5.6-4. Crew transportation module and reference RLV interface.

- RLV operates autonomously (i.e., uncrewed) for cargo delivery and return and operates in a crewed mode for rotation of ISS personnel
- RLV will dock to U.S. on-orbit segment (USOS) of ISS
- RLV will utilize a set of pressurized and nonpressurized carriers optimized for vehicle capability and ISS delivery needs
- RLV crewed configuration utilizes a CTM to provide a variety of crew functions, vehicle monitoring functions, and command and control capability
- RLV will accommodate delivery of pressurized and unpressurized cargo nominally delivered by the Shuttle; this includes “free” cargo provided by Shuttle systems (for example, gaseous O₂ and N₂ siphoned from Shuttle cryogenic tanks, water provided by Shuttle fuel cells, and orbital maneuvering system (OMS) propellant transferred to ISS propulsion module (PM)), and ISS cargo booked as Shuttle liens including EVA suits
- RLV does not include a robotic arm; removal of elements from RLV payload bay will require use of SSRMS
- Neither RLV nor CTM include an airlock; no EVA capability is provided via RLV, CTM, or cargo carriers
- Ground processing of RLV, cargo carriers, and CTM is assumed to occur at Kennedy Space Center (KSC)

5.6.4. External and Internal Interfaces

The RLV will rendezvous and dock with the USOS portion of the ISS. The primary docking port for the RLV will be PMA 2 on node 2 as used by the Space Shuttle. Requirements for RLV internal and external interfaces to the ISS are given in SSP 50235 (Interface Definition Document for International Space Station Visiting Vehicles, Section 4.0—Interface Requirements).

5.6.4.1. General Interface Requirements

The following general interface requirements will be provided by the RLV:

- Compatibility of RLV ECLSS with that of ISS
- Pressurization for RLV mating compartment and all RLV pressurized areas
- Compatibility of thermal modes of RLV and ISS operational systems, assemblies, and structures
- Compatibility of electrical operational modes and characteristics of RLV and ISS, including electrical power parameters, methods of commutation, and electric circuit protection
- Compatibility of RLV and ISS C&DH systems software and hardware
- Compatibility with RF and telemetry formats of existing ISS communication systems; RLV will meet the coverage requirements of specified ranges to ensure safety during rendezvous and mating process
- Electromagnetic compatibility of RLV and ISS equipment, as specified in SSP 30237 (Space Station Electromagnetic Emission and Susceptibility Requirements) and SSP 30243 (Space Station Systems Requirements for EMC)
- RLV will satisfy the quiescent and nonquiescent requirements for ISS external contamination and control inputs in accordance with SSP 30426 (Space Station External Contamination Control Requirements) with the specific allocations to be agreed by ISS and RLV programs
- RLV will meet specified performance when exposed to the on-orbit natural environments shown in SSP 30425 (Space Station Program Natural Environment Definition for Design)
- RLV will provide necessary access to ISS elements to perform EVR and EVA operations
- RLV will be compatible with ISS altitude profile at a range of 350 to 460 km at an inclination of 51.6°
- During approach and docking, RLV is always an active element, whereas ISS is passive
- RLV will meet all docking force limit requirements (dynamic parameter value limit requirements) for particular port to which vehicle is planned to dock
- All RLV hardware and software which has a crew interface will be designed in accordance with SSP 50005 (ISS Flight Crew Integration Standard)

- RLV using TDRS to communicate to the ground centers will comply with requirements of 530-SNUG (Space Network User's Guide)

5.6.4.2. U.S. On-Orbit Segment Interface Requirements

When attached to the USOS, the RLV will be compatible with the USOS requirements in SSP 41162 (USOS Specification) as follows:

- On the USOS, the RLV will dock only at the autonomous peripheral docking system (APDS) at PMA 2 on the node 2 forward port; interfaces for this port are described in NSTS 21000-IDD-ISS (Interface Definition Document for the International Space Station)
- Electrical systems of RLV interfacing with the USOS will be compatible with 120 V dc power according to SSP 30482 (Electric Power Specifications and Standards, Vol. 2: Consumer Constraints)
- RLV C&DH system will be compatible with MIL-STD-1553B (Digital Time Division Command/Response Multiplex Data Bus)
- RLV designers will use standard EVA tool set available onboard ISS as defined in SSP 30256 (EVA Standard ICD)

5.6.5. Enhanced ISS Configuration

Figure 5.6-5 illustrates an RLV approaching ISS for docking at PMA 2.

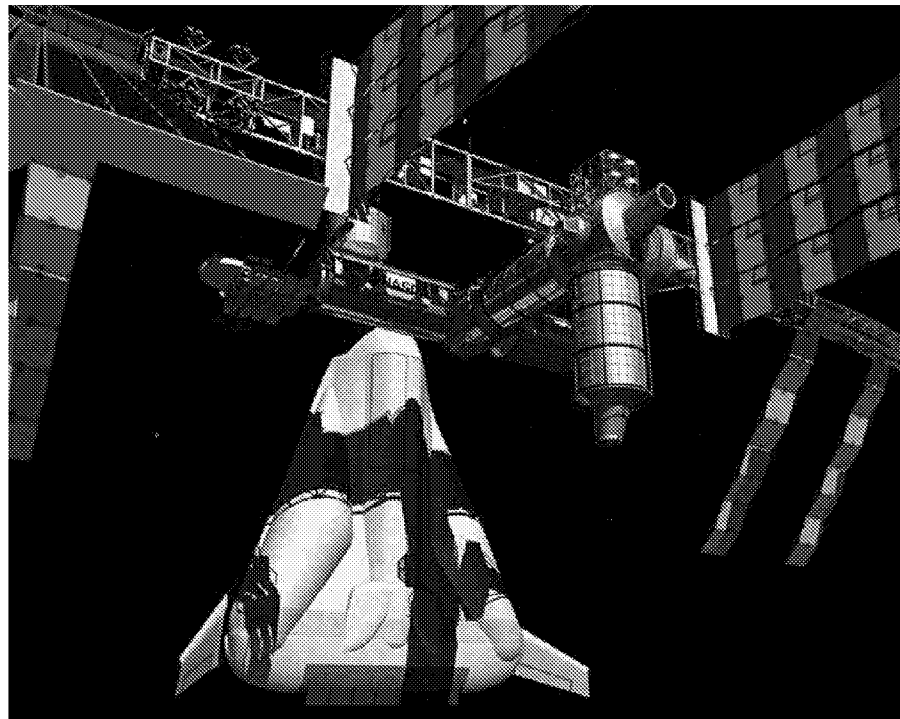

Figure 5.6-5. RLV docking to ISS PMA 2.

5.6.6. ISS Impacts

In order to facilitate a cost-effective transition from the Space Shuttle to a new RLV transportation system, a philosophy of minimizing impacts to the baseline ISS Program is required. As defined in section 5.6.4, the new RLV system is envisioned to operate in the vicinity and while attached to the ISS much like the Space Shuttle to minimize potential ISS impacts. When a new RLV system cannot fully emulate the Space Shuttle, potential impacts to ISS systems and operations may result. Example impacts are described as follows.

5.6.6.1. Installation

Not applicable.

5.6.6.2. Vehicle Configuration

When docked to the ISS, an RLV is considered part of the on-orbit Space Station and must be compatible with the requirements documented in SSP 41000 (System Specification for the International Space Station) and/or the associated segment specifications (SSP 41162 (United States On-Orbit Specification), SSP 41167 (Mobile Servicing System Segment Specification for the International Space Station Program)). Deviations from these requirements must be assessed on a vehicle-specific basis.

To ensure compliance with SSP 41000, implementation of a new transportation system requires the complete analysis of RLV-ISS proximity operations and docking including nominal approach and abort trajectories; plume loads; docking loads; combined vehicle mass properties, flight attitude, and CMG requirements to fly at torque equilibrium attitude (TEA); separation trajectory; and separation plume loads.

5.6.6.2.1. Mass Properties

See section 5.6.6.2.

5.6.6.2.2. Flight Attitude

Initial analysis of ISS flight characteristics with a docked Shuttle-class RLV has been performed by the Langley Research Center (LaRC) based on the assumption of an orbital inclination of 51.6° on spring equinox at an altitude of 225 nmi. A “design” atmosphere and the preliminary design review (PDR) control law were used in all simulations.

The TEA for the ISS AC configuration without a docked RLV is approximately -3.5° in yaw and -10° in pitch as illustrated in figure 5.6-6(a). The TEA for the ISS with a docked RLV is approximately $+30^\circ$ in pitch. The roll and yaw TEA components are small. The reason for the large pitch TEA is the large principal-to-body axes offset in pitch arising from accommodating the RLV. The attitude oscillations about the TEA during the controlled simulation show well-behaved, once-per-orbit oscillations as illustrated in figure 5.6-6(b).

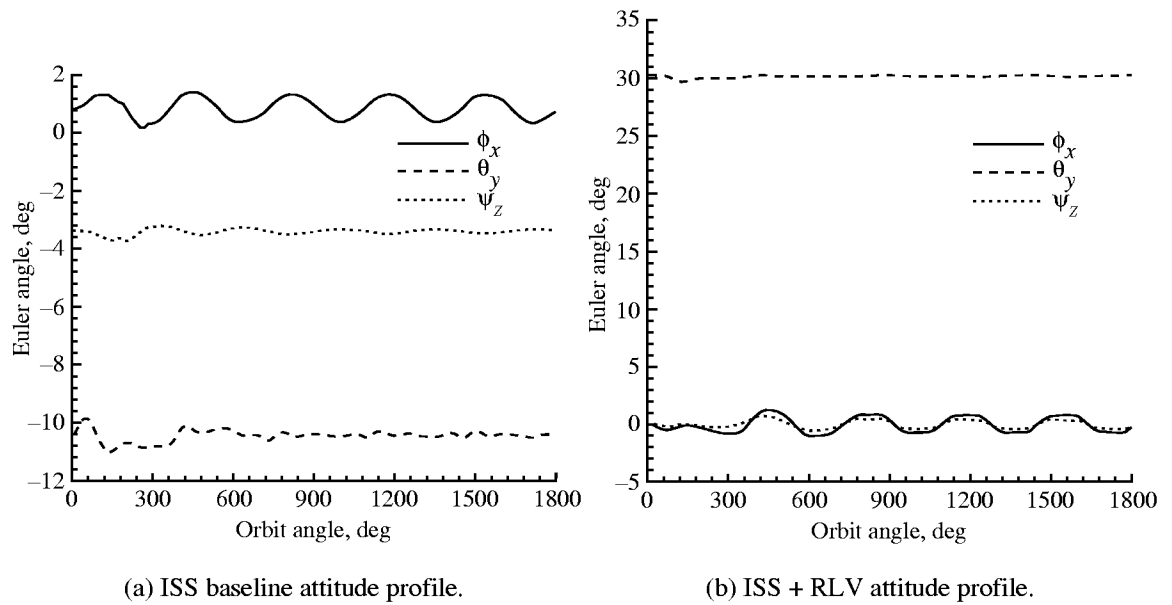

Figure 5.6-6. ISS attitude profile with and without docked RLV.

5.6.6.2.3. Control

Results of the LaRC analysis show that the peak steady-state CMG momentum requirement for the ISS AC configuration without a docked RLV is approximately 5000 N-m-s as illustrated in figure 5.6-7(a). The CMG momentum requirement for the ISS with a docked RLV is approximately 7000 N-m-s as shown in figure 5.6-7(b).

5.6.6.2.4. Orbital Lifetime

A revised ISS reboost plan will be necessary to optimize ISS propellant usage based on RLV flight rate, ISS altitude strategy, and international visiting vehicle traffic.

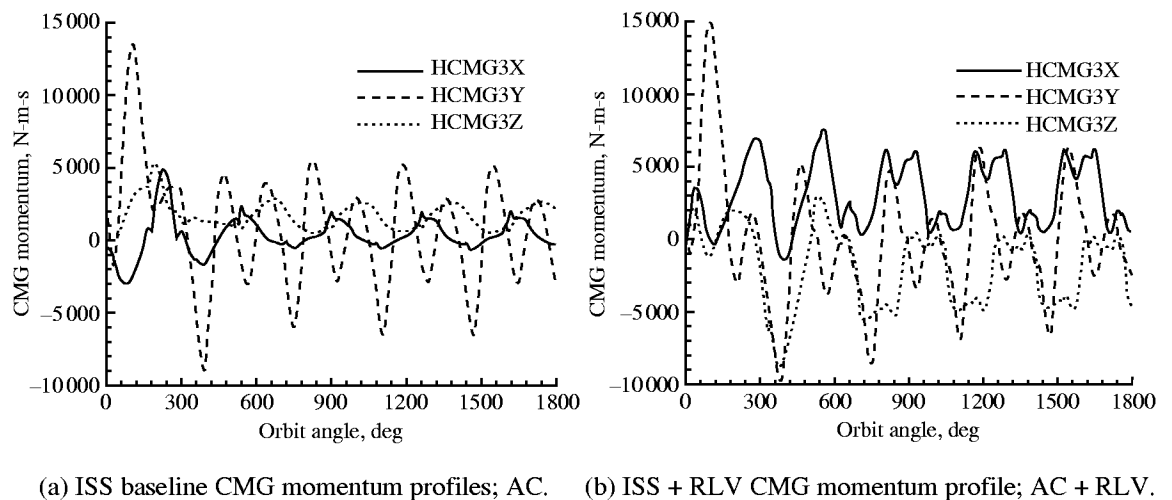

Figure 5.6-7. ISS CMG momentum profile with and without docked RLV.

5.6.6.3. Operations

An overview of the reference RLV mission profile for resupply of pressurized and unpressurized cargo is shown in figure 5.6-8. Although the timeline estimates are based on analyses specific to the VentureStar RLV, the mission phases are considered representative of a generic RLV-ISS resupply mission.

The RLV rendezvous profile will be designed to meet ISS visiting vehicle requirements (section 5.6.6.3.4) and RLV system requirements. The 43-hr period from RLV launch to ISS dock shown in figure 5.6-8 ensures an RLV orbital phasing capability of 360°, which provides a launch opportunity on any given day.

RLV-ISS attached operations will be dedicated to cargo transfer and/or crew handover. The 182-hr period shown in figure 5.6-8 is based on estimates required to transfer a pressurized cargo carrier to ISS, transfer cargo to and from the pressurized cargo carrier, reinstall the pressurized carrier in the RLV payload bay, and exchange an arriving unprocessed cargo carrier in the RLV payload bay with a returning unpressurized cargo carrier on ISS.

The 12 hr estimated for separation from ISS through landing provides adequate time for landing opportunities at potentially multiple landing sites in the United States and allows time for any necessary entry preparation activities by the RLV ground controllers.

The 48-hr contingency budget provides for a 24-hr rendezvous delay prior to ISS docking, up to 48 hr for entry wave-off, and/or a potential for extended RLV-ISS attached operations.

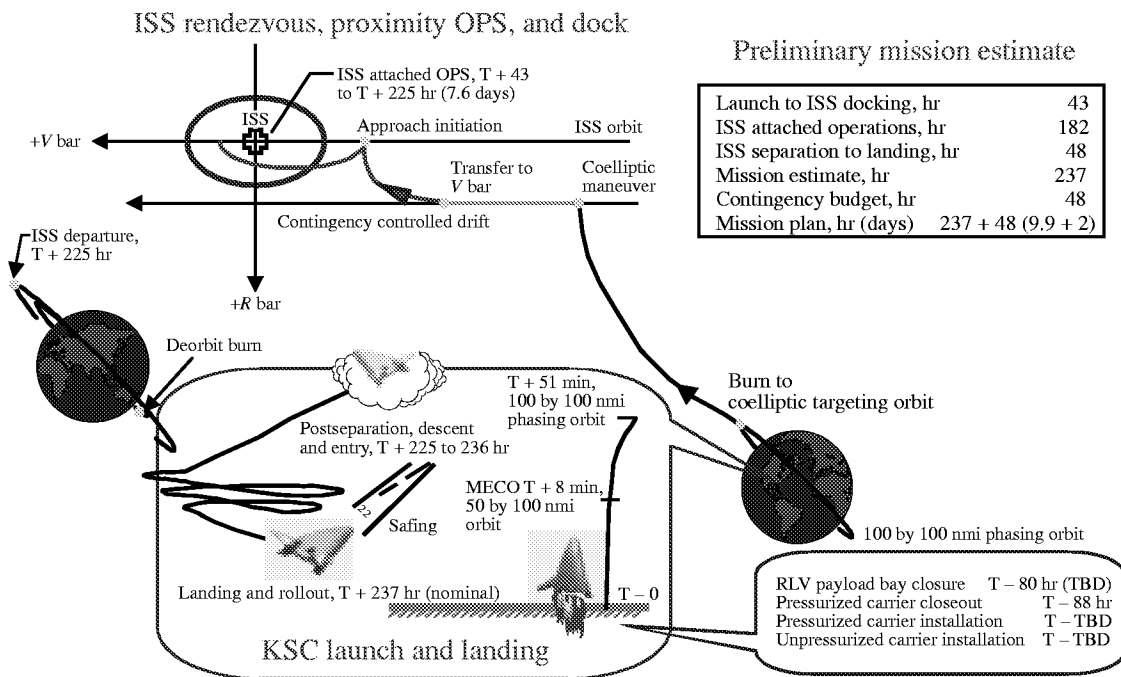

Figure 5.6-8. Overview of reference RLV pressurized and unpressurized cargo resupply mission.

A major objective of RLV operators will be to minimize the duration of RLV–ISS attached operations without compromising mission objectives. Minimizing RLV–ISS attached operations may limit sizing requirements for certain RLV subsystems and will limit RLV consumables requirements during this mission phase. Savings in RLV subsystem and consumables mass will provide an approximately equivalent increase in payload-to-orbit capability. Also, shorter RLV missions to ISS may facilitate additional RLV flight opportunities for commercial payloads.

Table 5.6-2 shows the estimated mission duration for four missions based on reference RLV capabilities.

Table 5.6-2. VentureStar RLV–ISS Mission Duration

RLV–ISS mission	Launch to docking, days	ISS attached operations, days, for—				Separation to landing, days	Contingency, days	Total mission duration, days
		PCC transfer	NPCC transfer	Cargo transfer	Crew handover			
Crew rotation	1.8	N/A	N/A	N/A	1.5–2.0	0.5	2.0	3.8–4.3 + 2
PCC with MLE cargo	1.8	N/A	N/A	7.0	N/A	0.5	2.0	9.3 + 2
PCC + NPCC	1.8	1.0	1.5	5.1	N/A	0.5	2.0	9.9 + 2
2 NPCC's	1.8	N/A	1.5 × 2	N/A	N/A	0.5	2.0	5.3 + 2

A key objective of the ISS Program will be to limit the annual RLV flight rate necessary to meet the requirements for ISS cargo resupply and crew rotation. This objective is a result of ISS quiescent period requirements levied to provide an idealized environment for microgravity research. (See section 5.6.6.4.1.) Because RLV attached operations are a major disturbance to the ISS microgravity environment, the goal for RLV flight rate should be to approach the projected Shuttle–ISS flight rate of 5 per year.

Figure 5.6-9 shows a typical annual flight rate estimate of 11 flights and the associated cargo manifests for VentureStar RLV support of ISS. This flight rate severely violates the ISS quiescent period requirement specified in section 5.6.6.4.1.

5.6.6.3.1. Intravehicular Activity

ISS IVA activities in support of RLV–ISS attached operations will include pressurized cargo transfer, unpressurized cargo carrier exchange utilizing the SSRMS, and crew handover operations. The principal impact to ISS IVA during RLV–ISS attached operations compared with baseline Shuttle–ISS attached operations is the lack of RLV crew to assist in cargo transfer.

Estimates for ISS IVA crew time required in support of RLV–ISS missions are given in table 5.6-2. These estimates are based on crew time analyses of transfer operations and handover operations provided in SSP 50391 (Crew Loading Report—International Space Station Program).

5.6.6.3.2. Extravehicular Activity

The SS–ISS operations plan specifies that the arriving Shuttle crew perform the majority of ISS USOS EVA maintenance. These EVA's will be performed by the sixth and seventh members of the Shuttle crew who are not part of the rotating ISS crew. If 2 EVA's are performed during each Shuttle flight, 10 EVA's per year will be performed by Shuttle crews.

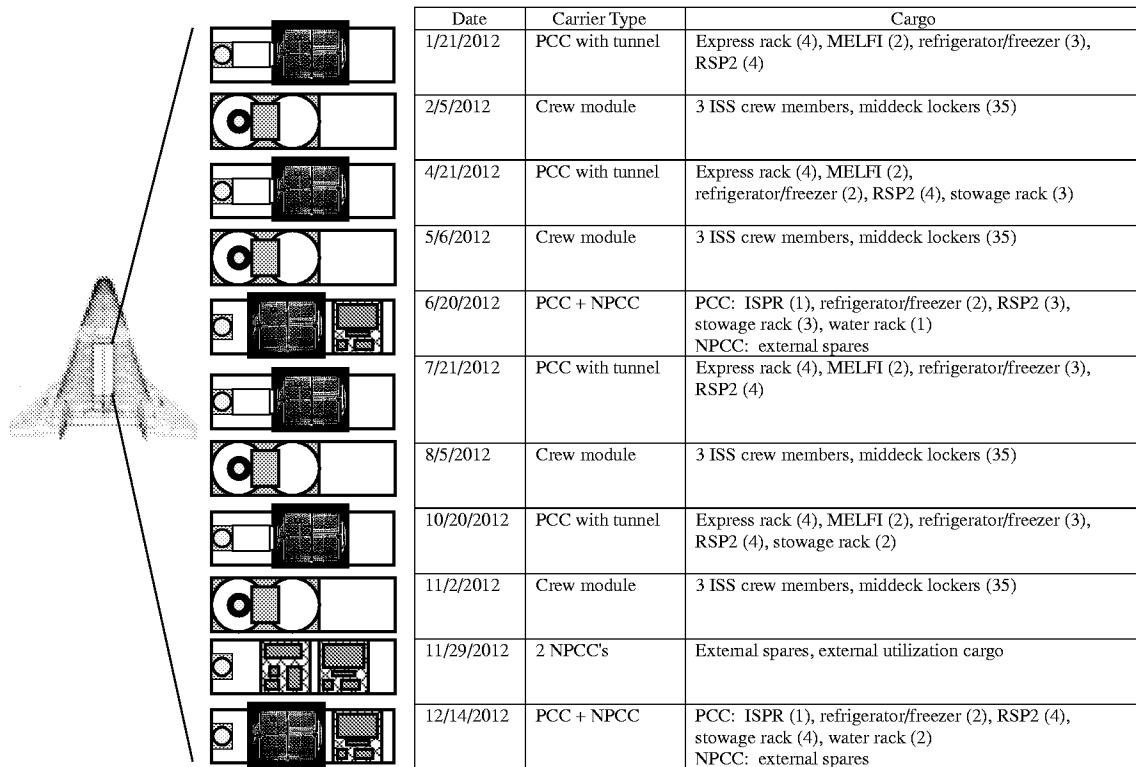

Figure 5.6-9. Typical reference RLV annual manifest for ISS support.

Because RLV flights will be either uncrewed cargo delivery flights or crewed flights limited to ISS crew and potentially a single RLV pilot, the capability to support ISS EVA maintenance during RLV-ISS attached operations may not exist. The primary impact will be the loss of approximately 500 crew hours per year nominally allocated to science which will be required for the additional EVA activities to be performed by the ISS crew.

EVA training may potentially be an issue for ISS crews since EVA teams may not be recently trained for the required EVA tasks. For example, an ISS crew member may be required to perform an EVA up to 90 days after arriving at ISS.

5.6.6.3.3. Ground Support Operations

Commercial RLV programs will likely evaluate multiple commercial and government options for location of ground support operations. Launch and landing sites may potentially be selected at multiple latitudes to optimize vehicle performance to orbit over a range of orbital inclinations. Availability of existing facilities and resources will also be a principal criterion in selection of ground support operations sites.

KSC is a likely location for RLV ground support operations for the ISS mission due to the in-place infrastructure including specialized facilities for ISS carrier processing and laboratories for support of life science flight experiments.

Figure 5.6-10 illustrates the ground support operations concept for the VentureStar RLV and ISS pressurized cargo carrier processing.

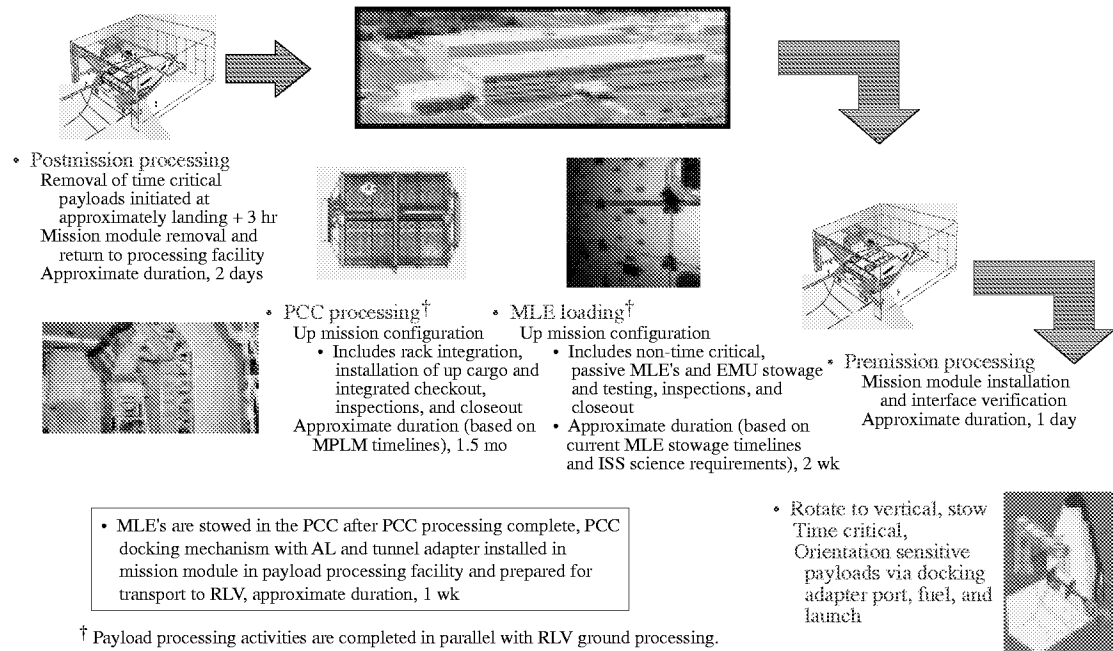

Figure 5.6-10. VentureStar RLV and Pressurized Cargo Carrier Ground Processing Operations.

5.6.6.3.4. Visiting Vehicle Operations

SSP 50235 (Interface Definition Document (IDD) for International Space Station (ISS) Visiting Vehicles (VV's)) defines performance and interface requirements that are specific to ISS vehicles including RLV's. Requirements include

- Major constraints
- Visiting vehicle proximity operations
- USOS interfaces
- Safety
- Verification
- Interaction of the visiting vehicle designer with ISS Program

Human rating requirements for the design and operation of new transportation systems, given in JSC 28354 (Human Rating Requirements), are classified as

- General (design for human flight, aerospace design practices, crew habitability, flight test, proximity operations)
- Safety and reliability (crew survival, crew escape, aborts, flight termination, failure tolerance, reliability verification, software reliability)
- Humans in the loop (crew role and insight, manual control, human-machine interface, task analysis)

Additionally, SSP 50261-01 (Generic Groundrules, Requirements, and Constraints—Part 1: Strategic and Tactical Planning, International Space Station Program) provides requirements for Shuttle flight manifesting and vehicle traffic planning including minimum time between Shuttle launches, open days between Shuttle undocking and the next ISS launch, and open days between international vehicle undocking and the next ISS Shuttle launch. For RLV–ISS traffic modeling purposes, the requirements for the Space Shuttle may be considered equivalent requirements for the RLV. Deviations from these visiting vehicle operations requirements must be assessed on a vehicle-specific basis.

5.6.6.4 Utilization

Potential ISS utilization impacts resulting from RLV transportation support are summarized in this section.

5.6.6.4.1. Microgravity

SSP 41000 (System Specification for the International Space Station) requires that the ISS provide a quiescent environment for microgravity research for at least 180 days per year in continuous time intervals of at least 30 days. Because vehicle docking and attached operations are major disturbances to the ISS quiescent environment, vehicle flight rate and scheduling are the principal factors in the ability to meet the ISS quiescent environment requirement.

The ISS quiescent environment requirement of 180 days per year in at least 30-day increments is accommodated with the Shuttle–ISS flight rate of approximately 5 per year in addition to projected IP vehicle traffic. However, VentureStar RLV–ISS flight rates shown in figure 5.6-6 are not able to support this requirement. Figure 5.6-11 shows that the annual quiescent environment days vary between 73 and 109 with an RLV flight rate of 10 to 11 per year (based on a delivery capability of 25000 lb to ISS in a circular orbit of 248 nmi with an inclination of 51.6°).

5.6.6.4.2. Payload Accommodations

The Space Shuttle middeck locker plan for ISS for post-AC support is shown in table 5.6-3. In addition to Space Shuttle Program (SSP) requirements and ISS crew and operations requirements, the ISS research community is allocated approximately 27.5 middeck lockers per Shuttle flight.

Because middeck lockers are a standard packaging system for ISS research payloads, RLV carriers will likely be required to develop a capability to transport middeck locker cargo. A resulting requirement for RLV pressurized carriers may be the capability to accommodate late/early access for prelaunch and postlanding support of life science middeck locker payloads. A potential impact to ISS research payload operations may be the lack of in-transit crew support if middeck lockers are manifested on uncrewed cargo flights.

5.6.6.4.3. Payload Operations

See sections 5.6.6.3.2 and 5.6.6.4.2.

5.6.6.5. ISS Subsystem Impacts

Potential RLV impacts to ISS subsystems during proximity operations and attached operations are summarized in this section.

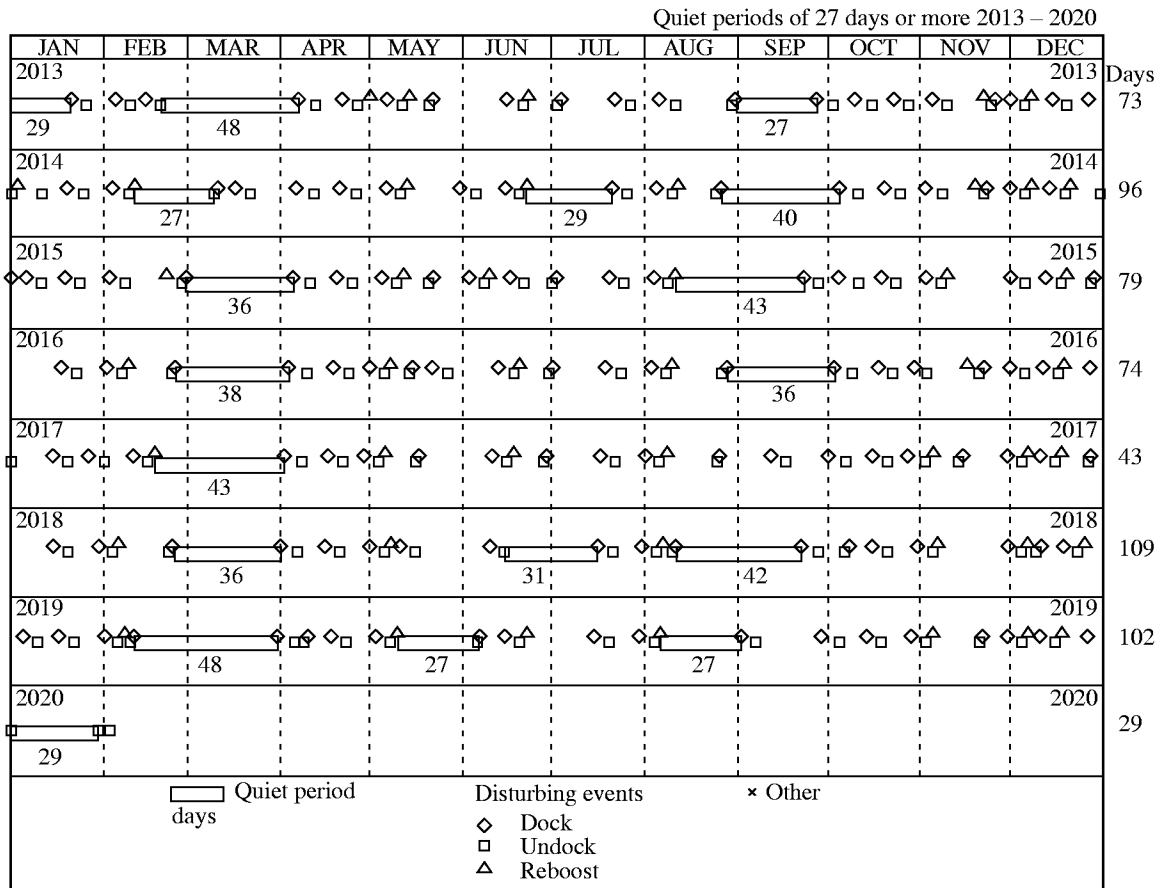

Figure 5.6-11. ISS quiescent period estimates with VentureStar RLV transportation support.

5.6.6.5.1. Command and Data Handling

Command and control capability of the RLV must adhere to the requirements documented in SSP 50235. Included in these requirements is the capability of the RLV to accept, acknowledge, and execute critical commands issued by the ISS crew, associated ISS Mission Control Center (MCC), or RLV Control Center (RLVCC). In an emergency situation, the RLV must be able to receive commands from the ISS, MCC, or RLVCC for termination of approach and docking operations (i.e., an abort). Implementation of this capability, including level of ISS control of the RLV, is vehicle specific and may require a modification or upgrade of ISS subsystems. Figure 5.6-12 illustrates a communications architecture concept to support command and control of the VentureStar RLV for an ISS mission.

5.6.6.5.2. Communications and Tracking

To ensure compliance with SSP 50235, the RLV should utilize communications systems available to the ISS to provide continuous communications with the ISS, MCC, and the RLVCC.

5.6.6.5.3. Crew Systems (IVA/EVA)

The Space Shuttle–ISS operations plan specifies that provisions for an arriving crew in support of their ISS tour will be manifested on their crew rotation flight. These provisions, including

Table 5.6-3. Shuttle-ISS Average Middeck Locker Requirements for Post-AC

Vehicle	Cargo	Middeck locker requirement, MLE's
Shuttle	Shuttle core mission + docking	
	Pantry food and menu food	4.5
	Clothing	6
	Hygiene	10.4
	Housekeeping	3
	IVA tools/IFM	4
	Camera	4.3
	Contingency EVA	2.5
	CWC's	4
	LiOH; miscellaneous Shuttle hardware	8.9
	ISS docking	<u>4.5</u>
	52.1	
ISS	Operations	
	SAFER	2.5
	Logistics and maintenance	5
	Photo/TV (core and flight specific)	4
	Station operations data files (SODF)	1
	Personal computer system resupply	1
	EVA tools	0.5
	Reserve lockers for late stowage	<u>3</u>
		17.0
	Crew	
Flight crew duration	4	
Care packages for nonrotating crew	1	
Crew rotation gear for rotating crew	<u>14.5</u>	
	19.5	
Research		
Operations summary allocations (Rev. B)	27.5	
Total		116.1

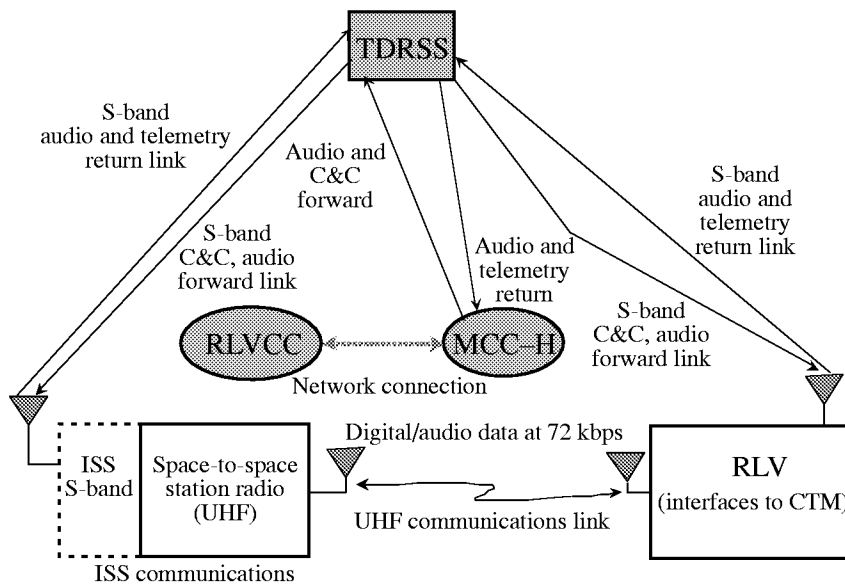

Figure 5.6-12. ISS-to-VentureStar RLV/CTM communications architecture overview.

food, clothing, and personal items, will be transported in an MPLM and in Shuttle middeck lockers.

The RLV, with potentially separate flights for cargo delivery and crew rotation, may not have the volumetric or mass-to-orbit capability to transport ISS crew and their provisions on a single flight. In this event crew provisions will necessarily be prepositioned, that is, delivered to ISS prior to the crew rotation flight.

The feasibility of prepositioning specific crew provisions and crew systems cargo will be determined by the ISSP. A potential impact is the unavailability of crew-unique cargo on ISS if a crew change occurs (e.g., due to illness) after the cargo delivery flight.

5.6.6.5.4. Environmental Control and Life Support Systems

The RLV may utilize ISS ECLSS consumables (water, atmospheric gases) while docked to ISS as a means to minimize RLV ECLSS consumable requirements. Any ISS consumables used by the RLV or RLV crew during attached operations will necessarily be resupplied by an RLV cargo or IP cargo flight.

5.6.6.5.5. Guidance, Navigation, and Control

See section 5.6.6.2.

5.6.6.5.6. Power

Power available through the ISS node 2 docking port for Space Shuttle support is specified in NSTS 2100-ISS-ISS (Interface Definition Document for the International Space Station). No impacts to the ISS power subsystem are anticipated for RLV-ISS attached operations if RLV power requirements are compatible with this specification.

5.6.6.5.7. Propulsion

See section 5.6.6.2.4.

5.6.6.5.8. Robotics

The RLV configuration for ISS missions may not include an RLV remote manipulator system (RMS). In this event the SSRMS will provide the robotic transfer capability for RLV carriers.

An SSRMS kinematic analysis will be required to determine SSRMS accessibility to the RLV carriers. This analysis will establish requirements for grapple fixtures on the RLV carriers and will define procedures for transfer operations.

5.6.6.5.9. Structures and Mechanisms

See section 5.6.6.2.

5.6.6.5.10. Thermal Control

Thermal rejection capability available through the ISS node 2 docking port for Space Shuttle support is specified in NSTS 21000-IDD-ISS. No impacts to the ISS thermal subsystem are anticipated for RLV-ISS attached operations if RLV thermal requirements are compatible with this specification.

5.6.6.6. Bibliography

- Amaral, James: System Specification for the International Space Station. SSP 41000R, Cage Identification No. 2B945, Boeing Co., Mar. 15, 2000.
- Anon.: Digital Time Division Command/Response Multiplex Data Bus. MIL-STD-1553B NOT 4, Jan. 15, 1996.
- Anon.: International Space Station Interface Definition Document. Space Flight Operations Contract, NSTS-21000-IDD-ISS, Rev. A, Boeing North American, Inc., Feb. 18, 1998.
- Boeder, Paul: Space Station Program Natural Environment Definition for Design. International Space Station Alpha, SSP 30425, Rev. B, NASA Johnson Space Center, Feb. 8, 1994.
- Brueggeman, James: Space Station Electromagnetic Emission and Susceptibility Requirements. International Space Station Program, SSP 30237, Rev. D, NASA Johnson Space Center, June 12, 1998.
- Brueggeman, James: Space Station Requirements for Electromagnetic Compatibility. International Space Station Program, SSP 30243, Rev. E, June 9, 1998.
- Gall, L.: Crew Loading Report—Review Copy. International Space Station Program, SSP 50391, Baseline, NASA Johnson Space Center, July 30, 1998.
- Harrington, James: Segment Specification for the United States On-Orbit. SSP 41162R, Cage Identification No. 2B945, Boeing Co., Mar. 15, 2000.
- Jenkins, Mike: Human-Rating Requirements. JSC-28354, NASA Johnson Space Center, June 1998.
- Johnson, Mike; Cook, Lowell E.; Griffin, Howard S.; Pugliese, Vincenzo; and Young, Freddie G.: United States On-Orbit Segment to Italian Mini Pressurized Logistics Module Interface Control Document—Part 2. International Space Station Program, SSP 42007, Rev. G, NASA Johnson Space Center, Feb. 13, 1998.
- Kirkland, Burl: Extravehicular Activity (EVA) Standard Interface Control Document. International Space Station Program, SSP 30256:001, Rev. F, NASA Johnson Space Center, Feb. 7, 1997.
- Langston, Linda: Generic Groundrules, Requirements, and Constraints—Part 1: Strategic and Tactical Planning. International Space Station Program, SSP 50261-01, Rev. A, NASA Johnson Space Center, Dec. 1998.
- Leonard, Marietta: Mobile Servicing System Segment Specification for the International Space Station Program. SSP 41167E, Rev. E, NASA Johnson Space Center, Oct. 15, 1997.
- Leonard-Hood, Dana: International Space Station Flight Crew Integration Standard (NASA-STD-3000/T). International Space Station Alpha, SSP 50005, Rev. A, NASA Johnson Space Center, June 3, 1994.
- Mikatarian, Ron: Space Station External Contamination Control Requirements. International Space Station Alpha, SSP 30426, Rev. D, NASA Johnson Space Center, Jan. 21, 1994.

Pascual, R. M.: Electric Power Specifications and Standards—Volume 2: Consumer Constraints. International Space Station Alpha, SSP 30482, Vol. 2, Rev. A, NASA Johnson Space Center, Jan. 1994.

Sampson, Margarita; and Derevenko, Valodimir: Interface Definition Document (IDD) for International Space Station (ISS) Visiting Vehicles (VVs), International Space Station Program Office, SSP 50235, NASA Johnson Space Center, Feb. 10, 2000.

Stocklin, Frank: Space Network (SN) Users' Guide. 530-SNUG, Rev. 7, Goddard Space Flight Center, Nov. 1995.

5.7. Rapid Delivery of Logistics to ISS (Launch Express)

5.7.1. Description

“Launch Express” is a concept for enhancing ISS logistics capabilities by providing a “launch-on-demand” service to ISS. Logistics and resupply items could be delivered on short notice to the ISS for contingency situations. This capability would allow short-term, quick turn-around missions (2–10 days) that would complement the planned orbiter and automated vehicle resupply missions.

5.7.2. ISS Enhancement Goal

The goals of ISS launch express are as follows:

1. Delivery of critical ORU's: Once an on-orbit critical spare is used, the ISS crew must wait for the next resupply flight to replenish the on-orbit backup; the new spare could be delivered within several days, perhaps preventing costly changes to the logistics manifest of the orbiter
2. Support of existing resupply vehicles: In the event of a delay or the catastrophic loss of a resupply vehicle, logistics supplies could be delivered to sustain ISS capabilities in the interim
3. Delivery of medical supplies: Medical supplies could be delivered quickly in the event of a unique medical situation, perhaps preventing the use of the CRV and loss of ISS operations
4. Delivery of payloads and payload resupply: The launch express capability could be used to deliver small payloads and associated instruments in the event of a near-term science opportunity

5.7.3. Enhancement Specifications

5.7.3.1. Physical Description

A potential implementation of the concept would use an air-launched vehicle to provide an accurate phasing of launches with the ISS orbit in order to quickly reach the ISS. Preliminary analysis indicates there are air-launched vehicles that can deliver approximately 350–400 kg to ISS orbit (407 km at 51.6°), with an estimated 100 kg of that mass being delivered equipment (i.e., ORU's, payloads, logistics). The launch express vehicle would consist of a standard small spacecraft bus with a capability to carry both pressurized and nonpressurized equipment.

5.7.3.2. Functional Description and Assumptions

Following launch and achieving an orbit appropriately phased with the ISS orbit, the launch express vehicle would rendezvous with the ISS and conduct proximity operations. The SSRMS or the JEM RMS would be used to grapple and capture the vehicle. The equipment portion of the vehicle could then be removed and inserted into the U.S. (or JEM) airlock, or an EVA could be conducted for retrieval and installation of external equipment.

The following assumptions were made:

- The launch express capability will be utilized after a permanent human presence is established on the ISS
- The launch express vehicle will be capable of automated and onboard (ISS) control for proximity operations
- The launch express will allow maximum use of SSRMS or JEM RMS and will only require EVA for particular operations

5.7.4. Interface Requirements

The launch express vehicle (spacecraft bus and attached equipment) will provide SSRMS or JEM RMS compatible grapple fixtures to support external capture and retrieval operations. The internal equipment delivered by the launch express vehicle will be compatible with internal logistics transportation devices such as middeck lockers and cargo transfer bags. The launch express vehicle will also be compatible with the ISS communications system for control during proximity operations.

5.7.5. Enhanced ISS Configuration Description

The enhanced ISS configuration will be the same as the baseline ISS configuration. The launch express capability would utilize existing SSRMS, JEM RMS, and airlocks.

5.7.6. ISS Impacts

5.7.6.1. Installation

Launch express has no special installation requirements. The launch express vehicle would not be installed to the ISS only grappled and would utilize existing SSRMS, JEM RMS, and airlocks.

5.7.6.2. Vehicle Configuration

5.7.6.2.1. Mass Properties

A launch express vehicle will have a mass of approximately 400 kg, with approximately 100 kg of that mass being payload.

5.7.6.2.2. Flight Attitude

TBD

5.7.6.2.3. Control

TBD

5.7.6.2.4. Orbital Lifetime

The launch express vehicle would have a limited orbital lifetime and the vehicle could depart from the ISS once the logistics, ORU's, et cetera, are retrieved.

5.7.6.3. Operations

5.7.6.3.1. Intravehicular Activity

IVA is required for control of the launch express vehicle during proximity operations and for SSRMS operation during capture of the vehicle.

5.7.6.3.2. Extravehicular Activity

EVA is required in situations where the hardware being delivered is needed externally on the ISS. EVA may also be required to assist with transfer of hardware from the launch express vehicle into the U.S. or JEM AL's for internal use.

5.7.6.3.3. Ground Support Operations

Ground control would initiate the launch express vehicle to move from an initial orbit to the ISS orbit. Control would be handed over to ISS crew for proximity operations.

5.7.6.3.4. Visiting Vehicle Operations

The launch express vehicle would adhere to all ISS visiting vehicle requirements.

5.7.6.4. Utilization

5.7.6.4.1. Microgravity

Launch express activities will be limited to defined time periods outside the ISS quiescent period to prevent disturbance of the ISS microgravity environment. However, ISS may allow a launch express vehicle to violate this requirement in the case of an extreme contingency situation.

5.7.6.4.2. Payload Accommodations

TBD

5.7.6.4.3. Payload Operations

TBD

5.7.6.5. ISS Subsystem Impacts

5.7.6.5.1. Command and Data Handling

No impact.

5.7.6.5.2. Communications and Tracking

The ISS communications subsystem would be used for controlling the launch express vehicle during proximity, capture, and berthing operations.

5.7.6.5.3. Crew Systems (IVA/EVA)

The launch express vehicle will be compatible with existing crew systems, such as EVA tools.

5.7.6.5.4. Environmental Control and Life Support Systems

No impact.

5.7.6.5.5. Guidance, Navigation, and Control

TBD

5.7.6.5.6. Power

TBD

5.7.6.5.7. Propulsion

TBD

5.7.6.5.8. Robotics

The SSRMS and the JEM RMS would be used to capture the launch express vehicle.

5.7.6.5.9. Structures and Mechanisms

A preliminary analysis showed that the launch express concept could accommodate approximately 78 percent of the ISS “critical” spares. A total of 94 critical spares, with mass and volume defined, were contained in the ISS “Horseblanket” spreadsheet. Of those 94 spares, 73 were less than the 100 kg estimated payload capability of the air-launched vehicle and had a volume within the JEM airlock capability (0.97 by 0.62 by 0.8 m). A detailed assessment is needed that takes into account the specific volume, attachment mechanisms, environmental conditions, et cetera.

5.7.6.5.10. Thermal Control

No impact.

5.7.7. Bibliography

Anon: Interface Definition Document (IDD) for International Space Station (ISS) Visiting Vehicles. SSP 50235, NASA Johnson Space Center, Jan. 1999.

6. Human Exploration and Development of Space

6.1. Overview

The mission of the Human Exploration and Development of Space (HEDS) Enterprise is to open the space frontier by exploring, using, and enabling the development of space and to expand the human experience into the far reaches of space. In exploring space, HEDS brings people and machines together to overcome challenges of distance, time, and environment. Robotic science missions survey and characterize other bodies as precursors to eventual human missions.

The Space Shuttle and ISS have and will serve, respectively, as research platforms to pave the way for sustained human presence in space through critical research on human adaptation. The NASA Strategic Plan states the ISS is the key to the NASA HEDS Enterprise and as such, the goals of the ISSP directly support the objectives of the Enterprise. These programs also provide opportunities for research with applications on Earth. HEDS serves as a catalyst for commercial space development. HEDS will employ breakthrough technologies to revolutionize human space flight.

6.1.1. Questions to Address

HEDS pursues the answers to a myriad of research and engineering questions that must be answered as we learn to live and work in space. HEDS plays an important role in pursuing answers to the question: What is the fundamental role of gravity and cosmic radiation in vital biological, physical, and chemical systems in space, on other planetary bodies, and on Earth, and how do we apply this fundamental knowledge to the establishment of permanent human presence in space to improve life on Earth? HEDS also plays an important role working with the other Enterprises to pursue answers to other fundamental questions, including Does life exist elsewhere than on our planet?

6.1.2. Goals

The goals of the HEDS Enterprise are as follows:

- Prepare to conduct human missions of exploration to planetary and other bodies in the solar system
- Use the environment of space to expand scientific knowledge
- Provide safe and affordable human access to space, establish a human presence in space, and share the human experience of being in space
- Enable the commercial development of space and share HEDS knowledge, technologies, and assets that promise to enhance the quality of life on Earth

6.1.3. Strategies and Outcomes

The HEDS Enterprise will contribute new scientific knowledge by studying the effects of gravity and the space environment on important biological, chemical, and physical processes. This

knowledge will provide fundamental insights for new Earth-bound applications and technology. Biomedical knowledge and technology will continue to be developed to allow people to thrive physically and psychologically while exploring and opening the space frontier.

The Enterprise relies on the robotic missions of the Space Science Enterprise to provide extensive knowledge of the geology, environment, and resources of planetary bodies. The Space Science Enterprise missions will also demonstrate the feasibility of utilizing local resources to “live off of the land.” HEDS will fully integrate and utilize the ISS, the Space Shuttle, and other international contributions. The Shuttle–Mir program demonstrates cooperation among spacefaring nations and the interlocking of various technical systems. The ISS will be the largest multinational science and engineering program in history and will vastly expand the human experience of living and working in space. This long-duration laboratory will provide unprecedented opportunities for science, technology, and commercial investigations in the space environment.

Research and technology development for advanced life support systems will be conducted terrestrially and will be validated on the ISS. HEDS will develop revolutionary advanced technologies that will support future national decisions regarding human missions beyond Earth orbit. HEDS will join with the private sector to stimulate opportunities for commercial development in space as a key to future settlement. Near-term efforts will emphasize joint pilot projects that provide clear benefit to Earth from the development of near-Earth space, whereas the long-term emphasis will be on the use of resources and environments of planetary bodies for the benefit of humankind and to sustain a human presence beyond Earth.

Safe, reliable, low-cost transportation is critical to the goals of the HEDS Enterprise. The Space Shuttle Program is committed to flying safely, meeting the manifest, improving system supportability and reliability, and reducing cost—in that order of priority. HEDS is implementing the Shuttle upgrade program to improve reliability, performance, and longevity of Space Shuttle operations to meet ISS needs and human exploration goals beyond 2012. HEDS will support efforts by the private sector to develop next-generation technologies for human travel and operations in space. Revolutionary new advanced transportation concepts for accommodating humans will be developed, including travel to distant destinations. The efforts of NASA will provide space operations management and communications services through commercial means while setting the stage for future investments that will be required as we explore the solar system and beyond.

HEDS employs a strategy that contributes to the national community, shapes activities to return near-term direct benefits, and clearly communicates these benefits to the Enterprise’s partners and customers, including the public.

6.1.4. HEDS Road Map

The road map presents the overall goals (presented in bold), objectives (presented as bullets), and major program milestones and related activities (presented in parentheses and italics) for the Enterprise. (See table 6.1-1.)

6.1.5. Bibliography

Anon.: The International Space Station—Improving Life on Earth and in Space. The NASA Research Plan, An Overview, NP-1998-02-232-HQ, NASA, 1998.

Anon.: NASA Strategic Plan. NASA NPD 1000.1, [1998].

Delheimer, JoElla; Thomas, Dawn; and Brinkley, Richard: Station Program Implementation Plan, Volume 1: Station Program Management Plan, International Space Station Program. SSP 50200-01, Baseline, NASA Johnson Space Center, Jan. 1998.

Table 6.1-1. Human Exploration and Development of Space Road Map

[Overall goals are in boldface type; objectives are bulleted items; major milestones and related activities are either in parentheses or italic type]

<p>Agency Mission</p>	<p>1998–2002 Establish a Presence <i>Deliver world-class programs and cutting-edge technology through a revolutionized NASA</i></p>	<p>2003–2009 Expand Our Horizons <i>Ensure continued U.S. leadership in space and aeronautics</i></p>	<p>2010–2023 Develop the Frontiers <i>Expand human activity and space-based commerce in the frontiers of air and space</i></p>
<p>To advance and communicate scientific knowledge and understanding of Earth, solar system, and universe and to use environment of space for research</p>	<p>Use environment of space to expand scientific knowledge</p> <ul style="list-style-type: none"> • Explore role of gravity and space environment in physical, chemical, and biological processes through vigorous peer-reviewed research program in space <p>Prepare to conduct human missions of exploration to planetary and other bodies in solar system</p> <ul style="list-style-type: none"> • With Space Science Enterprise, carry out integrated program of robotic exploration of Mars to characterize potential for human exploration to support definition decision or human exploration as early as 2005 	<p>Use environment of space to expand scientific knowledge</p> <ul style="list-style-type: none"> • Explore role of gravity and space environment in physical, chemical, and biological processes through vigorous peer-reviewed research program in space <p>Prepare to conduct human missions of exploration to planetary and other bodies in solar system</p> <ul style="list-style-type: none"> • Advance biomedical knowledge and technologies to maintain human health and performance on long-duration missions before 2008 	<p>Use environment of space to expand scientific knowledge</p> <ul style="list-style-type: none"> • Use human capabilities to extend scientific breadth and depth of new technologies including origin, evolution, and destiny of life
<p>To explore, use, and enable development of space for human enterprise</p>	<p>Prepare to conduct human missions of exploration to planetary and other bodies in solar system</p> <ul style="list-style-type: none"> • With Space Science Enterprise, carry out integrated program of robotic exploration of Mars to characterize potential for human exploration to support definition decision or human exploration as early as 2005 	<p>Prepare to conduct human missions of exploration to planetary and other bodies in solar system</p> <ul style="list-style-type: none"> • Advance biomedical knowledge and technologies to maintain human health and performance on long-duration missions before 2008 	<p>Conduct human missions to planetary and other bodies in solar system</p>

Table 6.1-1. Continued

<p>Agency Mission</p> <p>To explore, use, and enable development of space for human enterprise</p>	<p>1998–2002</p> <p>Establish a Presence</p> <p><i>Deliver world-class programs and cutting-edge technology through a revolutionized NASA</i></p> <ul style="list-style-type: none"> Establish requirements and architecture for human exploration that can radically reduce cost through use of local and/or system resources, advanced propulsion technologies, commercial participation, and other advanced technologies <p>Provide safe and affordable human access to space, establish a human presence in space</p> <ul style="list-style-type: none"> Sustain Space Shuttle program operations by safely flying manifest scheduled missions and aggressively pursuing systems upgrade program that will reduce payload-to-orbit costs by a factor of 2 by 2002 	<p>2003–2009</p> <p>Expand Our Horizons</p> <p><i>Ensure continued U.S. leadership in space and aeronautics</i></p> <p>Enable commercial development of space and share HEIDS knowledge, technologies, and assets that promise to enhance quality of life on Earth</p> <ul style="list-style-type: none"> Facilitate use of space for commercial products and service resulting in participation of at least 200 private firms by year 2002, and 100 percent increase in level of industry-committed resources by 2005 (ISS utilization) Achieve early cost savings in space communications and lay a foundation to permit privatization and/or commercialization of NASA space communication operations by no later than 2005 	<p>2010–2023</p> <p>Develop the Frontiers</p> <p><i>Expand human activity and space-based commerce in the frontiers of air and space</i></p> <p>Conduct human missions to planetary and other bodies in solar system</p>
------------------------------------------------------------------------------------------------------------------	-------------------------------------------------------------------------------------------------------------------------------------------------------------------------------------------------------------------------------------------------------------------------------------------------------------------------------------------------------------------------------------------------------------------------------------------------------------------------------------------------------------------------------------------------------------------------------------------------------------------------------------------------------------------------------------------------------------------------------------------------------------------------------------------------------------------	----------------------------------------------------------------------------------------------------------------------------------------------------------------------------------------------------------------------------------------------------------------------------------------------------------------------------------------------------------------------------------------------------------------------------------------------------------------------------------------------------------------------------------------------------------------------------------------------------------------------------------------------------------------------------------------------------------------------------------------------------------------------	-----------------------------------------------------------------------------------------------------------------------------------------------------------------------------------------------------------------------------------------------

Table 6.1-1. Continued

<p>Agency Mission</p>	<p>1998–2002 Establish a Presence <i>Deliver world-class programs and cutting-edge technology through a revolutionized NASA</i></p> <ul style="list-style-type: none"> Expand permanent human presence in LEO by making transition from Mir to ISS program in order to enhance and maximize science, technology, and commercial objectives Ensure health, safety, and performance of space flight crews through cutting-edge medical practice using advanced technology 	<p>2003–2009 Expand Our Horizons <i>Ensure continued U.S. leadership in space and aeronautics</i></p> <ul style="list-style-type: none"> Develop plan for privatizing Shuttle operations and implement by 2002; establish feasibility of commercializing Space Shuttle and some ISS operations by no later than 2005 	<p>2010–2023 Develop the Frontiers <i>Expand human activity and space-based commerce in the frontiers of air and space</i></p> <p>Conduct human missions to planetary and other bodies in solar system</p>
<p>To explore, use, and enable development of space for human enterprise</p>	<p>Provide safe and affordable human access to space, establish human presence in space, and share human experience of being in space</p> <ul style="list-style-type: none"> Involve U.S. citizens in adventure of exploring space, engage educators and students to promote educational excellence, and use human space flight to promote international cooperation 	<p>Provide safe and affordable human access to space, establish human presence in space, and share human experience of being in space</p> <ul style="list-style-type: none"> Involve U.S. citizens in adventure of exploring space, engage educators and students to promote educational excellence, and use human space flight to promote international cooperation 	<p>Provide safe and affordable access to space, establish a human presence in space and share human experience of being in space</p> <ul style="list-style-type: none"> Expand technology base for exploring and developing space
<p>To research, develop, verify, and transfer advanced aeronautics, space, and related technologies</p>	<p>Provide safe and affordable human access to space, establish human presence in space, and share human experience of being in space</p> <ul style="list-style-type: none"> Involve U.S. citizens in adventure of exploring space, engage educators and students to promote educational excellence, and use human space flight to promote international cooperation 	<p>Provide safe and affordable human access to space, establish human presence in space, and share human experience of being in space</p> <ul style="list-style-type: none"> Involve U.S. citizens in adventure of exploring space, engage educators and students to promote educational excellence, and use human space flight to promote international cooperation 	<p>Provide safe and affordable access to space, establish a human presence in space and share human experience of being in space</p> <ul style="list-style-type: none"> Expand technology base for exploring and developing space

Table 6.1-1. Concluded

<p>Agency Mission</p> <p>To research, develop, verify, and transfer advanced aeronautics, space, and related technologies</p>	<p>1998–2002 Establish a Presence</p> <p><i>Deliver world-class programs and cutting-edge technology through a revolutionized NASA</i></p> <ul style="list-style-type: none"> Invest in advanced concepts that may produce breakthroughs in human exploration and commercial development of space <p>Enable commercial development of space and share HEDS knowledge, technologies, and assets that promise to enhance quality of life on Earth</p> <ul style="list-style-type: none"> Transfer knowledge and technologies, and promote partnerships to improve health and enhance quality of life 	<p>2003–2009 Expand Our Horizons</p> <p><i>Ensure continued U.S. leadership in space and aeronautics</i></p> <ul style="list-style-type: none"> Invest in advanced concepts that may produce breakthroughs in human exploration and commercial development of space <p>Enable commercial development of space and share HEDS knowledge, technologies, and assets that promise to enhance quality of life on Earth</p> <ul style="list-style-type: none"> Transfer knowledge and technologies, and promote partnerships to improve health and enhance quality of life 	<p>2010–2023 Develop the Frontiers</p> <p><i>Expand human activity and space-based commerce in the frontiers of air and space</i></p> <p>Promote commercial development of space and share HEDS knowledge, technology, and assets that promise to enhance quality of life on Earth</p> <ul style="list-style-type: none"> Demonstrate new systems and capabilities to enable U.S. Industry to develop new, profitable space industries
---------------------------------------------------------------------------------------------------------------------------------------------	----------------------------------------------------------------------------------------------------------------------------------------------------------------------------------------------------------------------------------------------------------------------------------------------------------------------------------------------------------------------------------------------------------------------------------------------------------------------------------------------------------------------------------------------------------------------------------------------------------------------------------------------------	----------------------------------------------------------------------------------------------------------------------------------------------------------------------------------------------------------------------------------------------------------------------------------------------------------------------------------------------------------------------------------------------------------------------------------------------------------------------------------------------------------------------------------------------------------------------------------------------------------------------	--------------------------------------------------------------------------------------------------------------------------------------------------------------------------------------------------------------------------------------------------------------------------------------------------------------------------------------------------------------------------------------------------------------------------------------------------------------------------------

6.2. Synergistic Applications of ISS for HEDS Exploration Missions

6.2.1. Introduction

The place is Mars—the planet that holds the prospect of life—and NASA officials say the International Space Station just might help humans get there someday. The plan is to use the outpost as a proving ground for new technology and the study of human endurance in space in preparation for a possible Martian expedition in the new millennium. “If we ever want to send people on very long missions, there’s a lot we still need to learn...We’d like to take advantage of anything that we can learn on the Station.” Doug Cooke, Manager, Mars Exploration Office, NASA Johnson Space Center.

A Mars mission would put enormous demands on the crew and the systems needed to get there, stay alive on the surface, and come home safely. NASA says the Space Station is the perfect place to tackle some of the challenges. Officials also say the ISS could have political benefits that could help Martian exploration.

The exploration of space outside of Earth orbit will be science driven—the science required to answer fundamental questions humans have asked for centuries: What is the origin of the solar system? How did it evolve? It begins with a technology program necessary for humans to build the infrastructure needed to explore and develop space. A number of testbeds are required for the development, testing, and implementation of technologies for exploration. These testbeds include microgravity which can certainly be located at the ISS. Testbeds may also be located in regions where the gravitational field is less than that of Earth gravity, but more than microgravity such as the Moon. In both areas, investigations into human factors research, long-duration spaceflight, and technology demonstrations can be accomplished and data and knowledge accumulated.

As with almost any exploration architecture, robotic missions will be conducted to planetary bodies in order to gather data and knowledge before committing a human crew to that destination. The precursor missions also provide opportunities to demonstrate key technologies applicable to both robotic and human missions.

The station can also provide a means for long-lead technologies to be designed, developed, tested, and possibly implemented that may bode well for both ISS and the exploration architecture. The recommended technology investment areas specifically for exploration are

- Space transportation
- Information and automation
- Sensors and instruments
- Advanced space power
- Human support

Each area of development is discussed in varying levels of details and, in most cases, the part that the ISS will play in the technology development or the benefit from various technologies is discussed. The technology road map showing the ISS in the technology development path is shown in figure 6.2.-1.

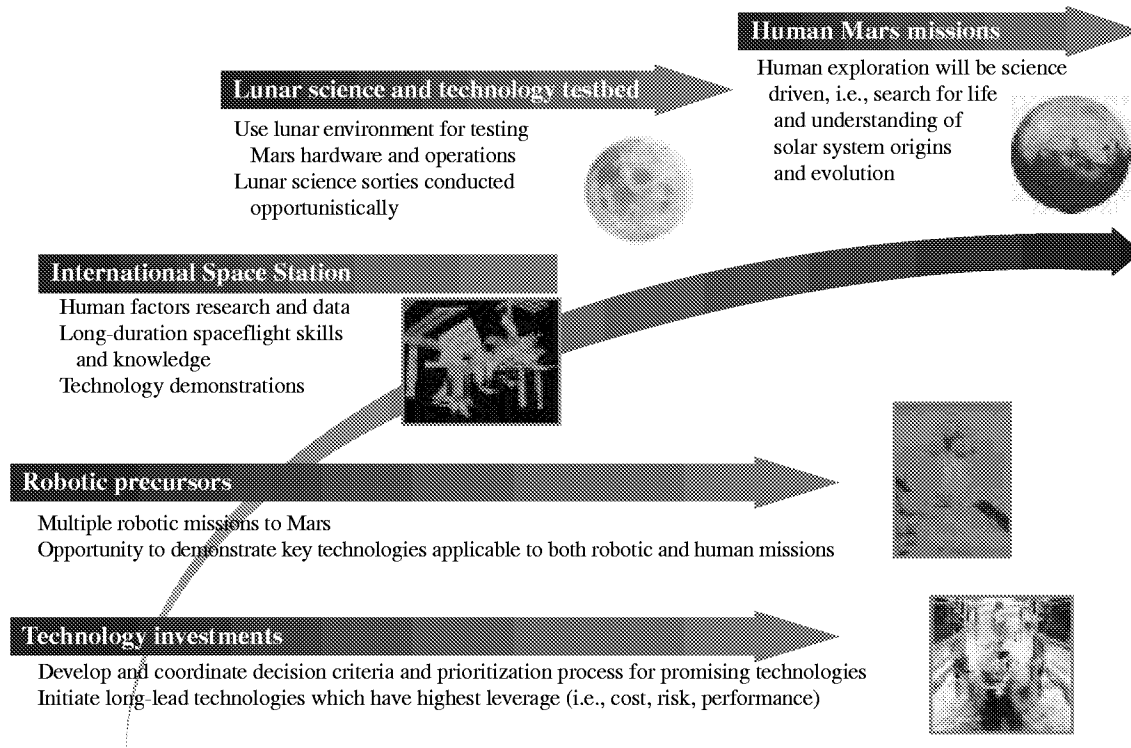

Figure 6.2.-1. Human exploration road map.

6.2.2. Assumptions

The ISS will only be considered as an orbital testbed for exploration technologies. With the development and analysis of exploration design reference missions requiring multiple launches of fully contained systems and crews, it is not necessary to park components of the mission in the ISS orbit for any period of time. In the event that assembly of large components of the mission is required, an ISS stopover may be warranted. But as of this time, no mission scenario utilizes the ISS as an assembly site in the exploration architecture.

6.2.3. Space Transportation

6.2.3.1. Affordable Earth-to-Orbit Transportation

A major hurdle to cross is the cost associated with getting the systems and crew out of the Earth's gravitational well. Current methods of achieving this fall solely on chemical propulsion. Without breakthroughs in Earth-to-orbit propulsion technologies, engineers reduce costs by being more efficient in the reduction of the mass required to place a system into Earth orbit. For exploration missions, especially piloted planetary missions, large launchers are required to place substantial elements of the transfer vehicles into orbit. Mass savings can be attained by improving the performance of lightweight tanks and structures; more efficient propulsion systems; lightweight, high-performing shrouds; and the expanded use of upper stages for in-space transportation.

Another goal is to accommodate large volume payloads in a single launch as well as minimize the on-orbit assembly costs. All these goals must be met with a minimum impact to the already existing launch facilities.

Candidates for Earth-to-orbit are the Shuttle-derived heavy lift vehicle (HLV), the Russian Energia-derived HLV, an all new HLV, or a commercial HLV. Mars injection is achieved by chemical, nuclear thermal, or electric propulsion. The latter propulsion options can also allow the vehicle to be captured into planetary orbits, such as orbits around Mars. ISS, by being a destination in the Earth-to-orbit segment of the infrastructure, will benefit by being able to receive logistics and payloads of greater mass and volume.

6.2.3.2. Advanced Interplanetary Propulsion

State of the art in interplanetary propulsion technology is chemical propulsion. Electric propulsion methodologies are now being demonstrated on robotic missions. Other means of interplanetary propulsion would include nuclear-electric and nuclear-thermal propulsion. Also, in the case of robotic precursor missions, one can also include both ascent and descent propulsion.

6.2.3.3. In-situ Resource Utilization and Cryogenic Fluid Management

Another efficient means of reducing the mass carried from Earth to other destinations is not to carry Earth return fuel on the outbound trip. Using indigenous resources at the destination, fuel can be generated and launched from the destination's surface. Once the fuel is generated, usually in the form of some cryogenic fluid, a number of considerations need to be addressed. There is the long-term storage of cryogenics (1700+ days), liquefaction and refrigeration of in-situ propellants, and the management and control of these fluids in microgravity. The ISS can benefit from the subsequent advances in cryogenic generation, liquefaction, refrigeration, and management of consumable commodities.

6.2.4. Information and Automation

In any exploration architecture, scientists need access to information created by the robotic and crewed systems, information acquired by the crew and robots, and a high level of autonomy within both the crewed and robotic systems. Two technological areas identified are communications and networks and intelligent systems and advanced operations.

6.2.4.1. Communications and Networks

The cornerstone of communications is the ability to transmit and receive information from many sources, sometimes concurrently. Three goals listed in exploration technology in the area of communications are high-bandwidth communications; robust communications capability at the exploration destinations; and fast and reliable data acquisition, transmission, and delivery to remote operations sites.

6.2.4.2. Intelligent Systems and Advanced Operations

Intelligent systems and advanced operations methodologies will enable crews to perform more science while keeping mundane tasks at a minimum. In the exploration architecture, one prefers

autonomous systems capable of operating independently, requiring no Earth-based control whatsoever.

A goal in exploration is to implement high levels of monitoring system health as well as managing faults when and if they occur. Performance support systems for the astronauts and ground operations personnel are essential for any exploration architecture. Augmentation of human performance can be achieved through the integration of robotic and human interfaces.

Robotics and automation systems provide tools and techniques for meeting exploration goals including predeployment and checkout of mission systems, remote operations of mission assets, and synergistic operations with the crew during exploratory endeavors. These tools and techniques benefit the mission by significantly improving crew productivity while reducing overall mission risks. Through the use of both Earth-based and crew-controlled intelligent processes, the efficiency of the crew in exploration and operation activities is increased. Three technology areas under investigation are machine perception, robotic dexterity, and intelligence for robots and other complex systems.

Two challenges are related to machine perception. The first challenge is the ability to recognize and track objects in extreme lighting conditions, including various reflectance properties, that may be partially occluded and inexact relative to a priori models. The second challenge is the ability to implement “eye-hand” coordination of robotic elements at near-human speeds.

A challenge for robotic dexterity is the ability to package arm and hand systems small enough to achieve human reach and dexterity while being mechanically reconfigurable. The dexterous robotic member should be designed for different functions with the ability to securely grasp (with one or more end effectors) and manipulate objects with humanlike speed (or better) and operate safely even with faults for long periods in extreme and varying environmental conditions.

The challenge associated with robotic intelligence is the ability to utilize software architectures for both autonomous and teleoperated control modes. Such modes should allow sharing between human operators and autonomous systems and have the ability to adapt and learn while replying to unplanned findings with humanlike speed or better.

All these goals in intelligent systems and advanced operations can be achieved through the initial implementation of elements on the ISS.

6.2.4.3. Intelligent Synthesis Environments

A state-of-the-art simulation-based engineering and analysis environment, specifically designed to accommodate all phases of development and execution, can integrate remote teams via a virtual environment to identify and mitigate risks to a given system. Such systems include ISS, space transportation vehicles, interplanetary vehicles, ground systems, and communications scenarios. Teams consisting of scientists, technology developers, and project engineers can all work together to perform what-if scenarios utilizing humans and technology to achieve the maximum science return. Such an environment, currently in development for ISS applications, can and will provide for a rapid and efficient systems analysis.

6.2.5. Sensors and Instruments

The development of sensors and instruments can be equally useful for ISS as well as for exploration. These sensors and instruments can be applied to four areas of exploration: science and engineering field laboratories, environmental and medical monitoring, planetary prospecting, and sample curation. Since these technologies will be high-performance instruments packaged in small volumes, a crosscutting technology would be that of microtechnologies and nanotechnologies. These technologies can be utilized in ISS as well as other programs and projects.

6.2.5.1. Science and Engineering Field Laboratories

The use of such science and engineering field laboratories will aid crews in determining whether the sites on which the laboratories reside are capable of supplying the resources a human crew needs. From an exploration viewpoint, the areas to be addressed with a laboratory are the analysis of in situ samples, analyzing the geology, and providing a virtual presence at the site. Imaging and remote sensing of a site need not be a remote site on another planet; the virtual presence can be utilized throughout the ISS.

6.2.5.2. Environmental and Medical Monitoring

Whether it be vehicles transporting crews to off-world destinations or extraterrestrial habitats for Earth crews to live while on a planet, the habitable areas are scaled versions of the ISS habitat adapted for application on a transport vehicle or a reduced gravity environment. Such habitable regions need to be monitored for fire, toxic materials, and radiation. The crew's food, water, and air also need to be monitored for purity and freshness. Whenever crews venture outside their habitat, the health of the life support systems as well as the health of the individual crew member needs to be monitored. Monitoring of specific systems can be extrapolated to more global systems such as planetary monitoring of climatic events in the case of a Mars expedition, monitoring and hazard avoidance of meteorites or other objects with probabilities of impacting the ISS. In the event of a crew member needing assistance from medical expertise outside the capabilities of the remaining crew members, a need exists for emergency medical systems or even a means of having a virtual presence of the care giver at the remote site. All crew-related monitors and medical systems have a direct application on ISS.

6.2.5.3. Sample Curation

Extraterrestrial samples need to be isolated in order to protect the Earth from unknowingly introducing contagions into the environment. Also, samples need to be parceled to various scientific organizations for individual studies. The issues associated with sample curations are long-term packaging and preservation and "witness-plate" monitoring, analysis of hazards and possible contaminants, and on-side caching and archival of samples. Technologies associated with sample curation can be extended to the handling of known biological contaminants and contagions that may be found in experiments onboard the ISS. As these technology road maps are being generated, more specific applications of such technologies can be identified.

6.2.6. Advanced Space Power

Another means of reducing the total mass to be launched to LEO is by implementing a more efficient power generation system, power storage device, and power management system. High-energy density generators and storage devices can be utilized to maximize energy management and minimize mass.

6.2.6.1. Advanced Power Generation

The next generation of power generation systems needs to be lightweight, high reliability, and highly efficient operation for many years. In the case of exploration, megawatt-class systems are needed for spacecraft propulsion, 100-kW-class fixed power systems for surface power, 10-kW-class mobile systems, and 1-kW-class systems capable of being transported by humans. Advanced photovoltaic systems ranging from 1 to 100 kW are needed to reduce mass associated with generating those energy levels. Solar dynamic systems are also needed in the 10 kW–1 MW class for exploration applications. The ISS can also benefit from demonstrations of these technologies that supply larger power levels to the ISS; thus, additional resources will be provided for increased experimental investigations. The benefits are reduced mass, volume, area, and life cycle costs. High-power, reliable long life systems can be applied to exploration as well as ISS applications; thus, the maintenance on those systems will be reduced. These power generation systems also enable a number of applications for outer planet applications.

The technology areas include high temperature materials for increasing system efficiency and reducing system mass; systems that convert thermal to electrical energy for radioisotope and nuclear materials; and low mass, low volume, higher efficiency (thus less area) solar conversion and high energy density storage. The challenge to new conversion technologies is the lifetime verification testing of the technology. The goal is multiyear; thus, a multiyear testing duration is required.

Most technology research is dependent on the decision to implement either nuclear or nonnuclear technologies for exploration applications and the successful demonstration of any system in its relevant environment.

6.2.6.2. Energy Storage

Two types of energy storage are needed for exploration applications: high-capacity regenerative fuel cells and lightweight battery options for long-term storage and fixed surface operations. Also, exploration applications need compact mobile systems such as batteries, fuel cells, or flywheel systems. These mobile systems can be implemented in EVA applications in and around the ISS.

Vehicle-class energy storage devices, Shuttle-class fuel cells, and regenerative fuel cells require fuel cells with 10000 hr of lifetime. Flywheels can also provide energy storage and a demonstration on ISS is required to substantiate the capability.

Portable energy storage devices need to be of low mass, low volume, and high energy density. Such devices can be used for handheld devices and robotic devices at extraterrestrial destinations as well as on the ISS. One path to achieving this goal is the enhancement of nickel-based and

lithium-based electrochemistry with energy densities in the 100 to 150 W-hr/kg range with high cycle lifetimes.

6.2.6.3. Power Management

New power management systems require one to two orders of magnitudes greater than the current state-of-the-art capability. The range of power management must range from kilowatts to megawatts. Such systems must also be reconfigurable and fault tolerant.

6.2.7. Human Support

A HEDS mission to the Moon or Mars is challenging if the “astronauts” are robots; adding a human crew to the mission poses additional significant challenges, both to the crew and to those planning and designing systems to support them. In fact, the human crew may be the most complex element of an exploration mission. Including a human crew provides several advantages, such as flexibility and the ability to adapt and solve novel problems, enhancing the probability of mission success, and maximizing data return. But there are also disadvantages associated with the inclusion of humans, such as the need for environmental control and life support, medical care, protection from the potentially debilitating effects of radiation and long-term microgravity. On an exploration-class mission, these human physical and psychological challenges are exacerbated by the associated distance and isolation because resupply and mission operations support from Earth would be significantly limited.

One focus of ISS research will be the impact of weightlessness on the human body. It already is known that humans suffer weakened bones, muscle deterioration, sleep disturbances, and other physical problems in orbit. Although men and women have been traveling in space for almost 4 decades, scientists have much to learn about such conditions before a Mars trip could get under way. “If we as a human species are ever going to explore deep space in 100 or 200 years, we have got to fully understand what effects the long-term presence in that kind of environment is going to have on human systems,” said Ray Askew, a senior scientist with the NASA Space Station Project. “We’re going to find out what the effects are so we can begin looking for accommodations and corrections for that, not just for the Space Station but for the future.” For example, doctors know bones and muscles suffer in space because the lack of gravity means astronauts do not work their bodies as they would on Earth. That is why Space Shuttle astronauts and crews on the Russian space station Mir exercise vigorously, running on treadmills and riding stationary bicycles. The same regimen will be followed on the ISS. So far, the workouts have kept space travelers reasonably toned. Still, U.S. astronauts and Russian cosmonauts returning to Earth from long stays on Mir need extensive rehabilitation.

In addition, the exercise does not fully mitigate the loss of calcium and corresponding weakening of bones. Astronauts lose about 5 percent of their calcium in space, and scientists are not sure if the degradation would increase to dangerous levels on a long Mars voyage.

Scientists also say they need to focus on the effects of space radiation on humans, and whether it increases the chances of cancer or genetic problems that could spur birth defects. Astronauts are subjected to elevated radiation levels in space because they are not protected by Earth’s atmosphere. “I think this is the biggest problem with human interplanetary travel—the high-energy radiation,” said Yusuf Jafry, a scientist with the European Space Agency. “The very high-energy penetrating radiation is certainly going to put crews at a certain amount of risk during any

envisioned trip to Mars,” said Anatoly Grigoriev, director of the Institute for Biomedical Problems in Moscow, who is considered the world’s top expert on long-duration space flight.

Beyond the physical effects, scientists have to learn more about the psychological ramifications of long-duration space flight, which puts astronauts in severe isolation and separates them from loved ones. For instance, Shuttle and Station crews can make emergency returns to Earth within 2 or 3 hr, if needed. But that would be impossible on a Mars mission, a factor that could weigh heavily on the minds of astronauts. “At some point, you pass a point of no return,” Grigoriev said. “And that is why the issue of isolation and confinement will become more important for people who will fly to Mars than those who will fly aboard the Space Station.”

Systems, equipment, facilities, and supplies developed specifically to support the astronaut crew in living and working during the mission—the “human factors”—are collectively called flight crew systems (FCS) and issues related to FCS on a Lunar or Mars mission are described in this section. FCS is not a “monolithic” system. That is, because the astronaut crew essentially comes into contact with every other vehicle system, equipment and provisions to support the crew are widely distributed throughout the vehicle or facility and are typically provided by multiple organizations, placing an additional burden on the integration discipline.

The FCS discipline serves the following functions:

1. Providing for and maintaining crew health
2. Mitigating the deconditioning effects of microgravity and radiation
3. Maintaining crew performance and providing effective workstations and task support equipment
4. Meeting habitability and crew accommodations requirements
5. Providing and managing routine and emergency provisions
6. Addressing crew training and skills maintenance
7. Providing a flight operations mission structure and support tools
8. Allowing crew maintenance of the vehicle and facility
9. Providing crew personal and mission support equipment

6.2.7.1. Flight Crew Systems Issues and Concerns

Issues associated with designing, developing, and integrating FCS into a HEDS mission are briefly described. Test and technology development programs to be conducted on an evolved ISS would be drawn from this list. All issues and concerns identified would need to be considered for both an Earth-Mars transit vehicle and a Mars surface habitat.

6.2.7.1.1. Crew Health Care, Biomedical Concerns, and Countermeasures

Providing medical care to the crew and maintaining their health and fitness are significant challenges on an exploration-class mission. A strategy for human space flight through exploration-class missions has evolved over a number of years, under the direction of John Charles of the JSC Space and Life Sciences Directorate (SLSD), through the “Critical Path Roadmap Project (CPRP).” The CPRP team identified 11 discipline risk areas to provide a structure for identifying issues and planning mitigation approaches and research. Identified risks have been assessed and ranked, critical mission-specific issues have been identified, and the risks were prioritized across disciplines. Risks were organized into three tiers: Tier I includes critical risks, Tier II includes very serious risks; and Tier III includes serious risks. Existing countermeasures that mitigate risks were identified and a CPRP cross-risk prioritization matrix was created. Some research and countermeasure development is presently being carried out (e.g., through the Space Biomedical NASA Research Announcement (NRA)) and may be applied to a HEDS mission. It is through the CPRP that research and technology development would be carried out on ISS, certainly within the Human Research Facility and perhaps through planned evolution. Much research in these discipline areas involves identifying and testing potential mitigation approaches and associated equipment. A baseline integrated critical path road map is in development. In addition, some testing and technology development addressing specific issues and concerns may be conducted within a 1g Earth-based environment. For example, a significant effort is presently being conducted to explore advanced life support technologies under realistic conditions (i.e., full crew, Mars surface-type habitat conditions) within the Bioplex at JSC (personal communication, Terry Tri).

The CPRP discipline risk areas defined are

- Advanced life support (e.g., advanced closed environmental control and life support system, atmosphere and temperature provision and control, waste handling and management)
- Bone loss (e.g., management of fractures, renal stones, osteoporosis)
- Cardiovascular/cardiopulmonary alterations (e.g., dysrhythmias, orthostatic intolerance, exercise capacity)
- Environmental health (e.g., monitoring air, water, and surface contamination; soil toxicity)
- Food and nutrition (e.g., preventing malnutrition; limiting food spoilage; enhancing palatability; potential supplementation; in situ food growth, harvesting, and production)
- Human behavior and performance (e.g., psychosocial support, long-duration isolation mitigation, workload, circadian factors, sleep-rest management, habitability, recreation, privacy needs)
- Immunology, infection, and hematology (e.g., infection, wound healing, allergens)
- Muscle alterations and atrophy (e.g., mass, strength, endurance)
- Neurovestibular adaptation (e.g., perceptual deficits, postural instability, fatigue)
- Radiation effects (e.g., carcinogenesis, central nervous system (CNS) damage, sterility)

Revision A, October 2000

- Clinical capability, space medicine, and surgery (e.g., diagnostic capabilities, pharmacy, supplies, emergency medical care, illness incidence estimation)
- Other biomedical related issues (e.g., postlanding adaptation)

Additional biomedical crew-related challenges that interact with the identified risk categories above include

- G transitions (long-term response to variable gravity conditions over the mission duration, i.e., $1g$ to $0g$ to $\frac{1}{3}g$ to $0g$ to $1g$)
- Prolonged periods of hypogravity and exposure to $\frac{1}{3}g$ (on the Mars surface)
- Potential for increased toxin exposure (including extraterrestrial) on the Mars surface
- Next generation, exploration-class EMU (wearing, maintaining, and servicing)
- Focused and high-intensity mission and surface activity (including high number of EVA's and increased risk of trauma)
- Significant autonomy of crew, especially with regard to providing medical support and decision making during an emergency
- Long-duration crew isolation

6.2.7.1.2. Crew Accommodations and Facilities

The crew accommodations area requires the definition of accommodations and facilities functions, shared and private areas, multiuse facilities, materials, and facility design for both the Earth-Mars transit vehicle and the Mars habitat area as follows:

- Galley (e.g., food processing, food and equipment storage and inventory management, nutrition management, preparation, cleaning and disinfecting)
- Wardroom and shared crew area (e.g., eating area, crew meeting room, recreation)
- Waste collection facility (e.g., advanced urinal or commode and waste processing)
- Personal hygiene facility (including whole body cleansing)
- Crew quarters (e.g., stowage of operational and personal items, privacy needs)
- Laundry facility
- Maintenance facility
- Architectural design issues (e.g., lighting; closeouts; decals, labeling and placards)

6.2.7.1.3. Crew Support Equipment and Provisions

The area of crew support and provisions includes

- Food system (daily menu, emergency provisions, EVA food)
- Personnel and equipment restraints and mobility aids (permanent and portable)
- Crew operational and personal provisions (including long-term clothing management)
- In situ and portable emergency provisions
- Housekeeping and trash management
- Stowage system
- Inventory management

6.2.7.1.4. Autonomy, Automation, Avionics, and Crew Integration

Factors related to autonomy, automation, avionics, and crew integration are as follows:

- Crew/avionics interfaces and interaction
- Crew workstations and crew-centered design
- Crew-centered design

6.2.7.1.5. In-Flight Maintenance

The area of in-flight maintenance includes

- Maintenance work area
- Tools
- Diagnostic and test equipment
- Logistics and sparing philosophy

6.2.7.1.6. Crew Safety and System Reliability

The issues related to crew safety and system reliability are as follows:

- Vehicle escape system
- Aborts scenarios (“Abort to Earth” options are limited; “Abort to Mars” requires definition)
- System safety and reliability

6.2.7.1.7. Flight Operations

Flight operations include

- Crew operations and activity planning
- Crew training and skill maintenance
- Command, control, and communications with Earth

6.2.7.1.8. Psychological and Psychosocial Issues

Some of the psychological and psychosocial issues are as follows:

- Number of crew
- Command structure
- Skill mix
- Cultural/international aspects
- Gender aspects
- Isolation and long duration considerations (research is being conducted in this area under a NASA JSC grant by Jack Stuster, Anacapa Sciences, Inc.)

6.2.7.1.9. Crew Extravehicular Activity and Exploration-Class Extravehicular Mobility Unit

There are significant challenges associated with developing an exploration-class EMU. The first challenge is the lack of EVA experience (there is more EVA “clock hours” experience within the Russian Space Agency than within NASA) although planned EVA’s for ISS should add to this limited database. Second, the amount of EVA required on a Mars mission for surface exploration places significant impact on both the EVA crew and the EMU itself. Third, the current EMU is inadequate to meet (1) the characteristics of the Mars surface environment (e.g., pressure, temperature, chemical composition, length of day, gravity field) and (2) the needs of the crew operating within this environment (e.g., mobility, dust proofing, wear resistance, oxygen supply, carbon dioxide removal, thermal control). An EVA research and technology road map has been developed by the JSC Crew and Thermal Systems Division (M. DeMasie, personal communication) that assumes technology testing on the ISS. The exploration EMU involves research and development in the following domains:

- Suit personal life support system (PLSS) regenerable CO₂ removal systems (e.g., reduce size, weight, and volume; increase reliability)
- PLSS oxygen systems (e.g., capability for cryogenic O₂ use)
- PLSS power supply systems (e.g., reduce size, weight, volume, and recharging time; increase endurance)

- PLSS thermal control systems (e.g., enhance heating and cooling, minimize consumables)
- Systems engineering and architecture (e.g., reduce size, weight, and complexity; increase reliability and safety; provide maintenance and repair capability)
- Lightweight, highly mobile suit systems (e.g., reduce suit weight, enhance mobility and glove dexterity)
- Human considerations (e.g., improved biomedical sensors, monitoring, and suit comfort; in-suit food and drink; waste management; monotony)
- Advanced suit displays and controls (e.g., voice recognition or command; robust voice and video; accessible controls)
- Human-robotic interface systems (e.g., self-propelled EVA caddies; pressurized or unpressurized rovers; sortie scout; complementary human-robot system)

Additional goals for an exploration EMU include on-back weight reduction; enhanced dust proofing; no prebreathe requirement; enhanced comfort for daily use; enhanced mobility; enhanced reliability; extended life support system. A Mars crew will also be required to provide regular in-situ EMU cleaning and servicing.

6.2.7.2. Advanced Habitation Systems

In addition to studies on humans, ISS astronauts will learn how to grow wheat, barley, and other crops that could help feed a Mars expedition or people living in a Martian colony. Furthermore, the ISS will allow engineers to work on new technologies that might be used on a Mars flight. One possibility is a prototype living module. Called TransHab, it would closely resemble a spacecraft that explorers could use during the journey to Mars. “TransHab’s name is based on its dual purpose as a transportation and living module” said Horacio De la Fuente, deputy manager of NASA TransHab Program. NASA officials are considering replacing the U.S. Hab (now under construction) on the ISS and use the inflatable TH in its place.

TH, made of multiple layers of lightweight, fire-resistant materials, would be launched deflated inside a Space Shuttle cargo bay. Once in orbit, TH would be maneuvered over the side by the SS robot arm. It would then be automatically inflated with air from attached tanks. The process would take about 8 hr. TH would be nearly three times larger than the Hab, which would allow more space for station passengers. Because it would be used on the ISS for at least 10 yr, engineers would have plenty of time to decide whether it would work on a Mars trip.

“Not only can TransHab offer Space Station a lot of advantages and a lot of benefits with its bigger size, but you also get a two-for-one where you can test some new technologies,” De la Fuente said. Even if TransHab is not used, engineers will be testing other ISS systems that could be used on a Mars journey. One is a water purification system developed at MSFC. The system uses chemicals and other processes to purify recycled water, urine and perspiration included. “That system may be used on a spacecraft making the long haul to Mars,” said Scott Croomes, the water system’s project manager. “If you were going on an extended mission to Mars, you would not want to depend on any one system,” Croomes said. “In all likelihood, a system like ours would be a very good backup.” For more information on the TH module concept, see section 5.5.

6.2.8. Bibliography

Anon: Exploration Programs Office: Human Exploration—Technology Challenges and Technology Roadmap Summaries. NASA Johnson Space Center, September 1997.

Charles, John B.: Briefing: A Strategy for Human Space Flight Through Exploration-Class Missions. Space and Life Sciences Directorate, NASA Johnson Space Center, August 1999.

DeMasie, Michael: Briefing: EVA Considerations for Planetary Exploration. Crew and Thermal Systems Div., NASA Johnson Space Center, Jan. 13, 2000.

National Research Council, Committee on Advanced Technology for Human Support in Space. *Advanced Technology for Human Support in Space*. National Academy Press 1997.

Sullivan, Thomas A.: Briefing: Requirements for Human Health and Performance on Long-Duration Space Flights. Space and Life Sciences Directorate, NASA Johnson Space Center, June 9, 1999.