

James Green* CR.Ashokkumar† A.Homaifar‡
 NASA Center of Research Excellence
 The North Carolina A & T State University
 Greensboro, NC 27411

ABSTRACT

This paper considers a given set of fixed order compensators for aircraft pitch control problem. By augmenting compensator variables to the original state equations of the aircraft, a new dynamic model is considered to seek a LQ controller. While the fixed order compensators can achieve a set of desired poles in a specified region, LQ formulation provides the inherent robustness properties. The time response for ride quality is significantly improved with a set of dynamic compensators.

1. Introduction:

While designing a feedback control, ride and handling qualities are major performance objectives in aircraft control problems. Such objectives are normally achieved by closed closed loop pole assignment [1]. Preserving these closed loop poles (within the desired regions) in the presence of perturbations is another requirement [2]. LQ problems have inherent stability margins to tolerate unstructured uncertainties. LQ design techniques with regional pole constraints have been studied extensively in the literature see [3], and its references]. Similar approach, but with dynamic compensators, have been investigated for automotive applications [4]. The compensators given in [5] for aircraft control problem are considered in LQ problem setting. The objective of this approach is to improve aircraft ride quality defined in [1].

II. Problem Formulation:

An aircraft model in pitch plane [with normal acceleration (n_z), pitch rate (q) and elevator deflection (δ_e) as state variables and command input (δ_c) as control variable], is given by [2]:

$$\dot{x} = \underbrace{\begin{bmatrix} a_{11} & a_{12} & a_{13} \\ a_{21} & a_{22} & a_{23} \\ 0 & 0 & -14 \end{bmatrix}}_A \underbrace{\begin{bmatrix} n_z \\ q \\ \delta_e \end{bmatrix}}_{z(t)} + \underbrace{\begin{bmatrix} b_1 \\ 0 \\ 14 \end{bmatrix}}_b u \tag{1}$$

It is well known that the control law

$$u(t) = -R^{-1}b' Px(t) + r(t) \tag{2}$$

minimizes the performance index

$$J = \int_0^\infty \{x' Q x + u' R u\} dt \tag{3}$$

and satisfies the algebraic riccati equation

$$A' P - P b R^{-1} b' P + P A + Q = 0 \tag{4}$$

Selection of weighting matrices to achieve a controller in equation 2 for exact pole assignment has been extensively investigated in reference [3]. Suppose, we choose a set of dynamic compensators given in [5] for the control law structure [2] (see Figure-1), then the state equations for the compensators are:

* Undergraduate Student, Dept. of Electrical Engineering.
 † Post Doctoral Research Associate.
 ‡ Associate Professor, Dept of Electrical Engineering.

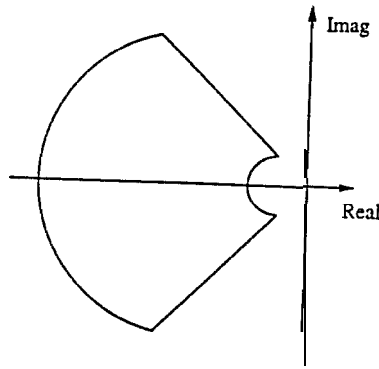

Figure 2: Regional Constraints for Aircraft

II. Simulation Results:

For F-4 aircraft model at Mach= 1.5, Altitude =35,000ft, the system dynamic matrices are given by:

$$A = \begin{bmatrix} -0.5162 & 26.96 & 178.9 \\ -0.6896 & -1.225 & -30.38 \\ 0 & 0 & -14 \end{bmatrix}$$

$$b = \begin{bmatrix} -175.6 \\ 0 \\ -14 \end{bmatrix}$$

The matrices \bar{A} and \bar{b} for the state vector $\bar{x}(t) = [x(t), z_1(t), z_2(t)]'$ are

$$\bar{A} = \begin{bmatrix} A & 0 & 0 \\ A_1 & -\tau_1 & 0 \\ A_2 & 0 & -\tau_3 \end{bmatrix}$$

$$\bar{b} = \begin{bmatrix} -175.6 \\ 0 \\ -14 \\ 0 \\ 0 \end{bmatrix} \quad \text{where,}$$

$$A_1 = [1 \ 0 \ 0]$$

$$A_2 = [-0.6896 \ (-1.225 + \tau_2) \ -30.38]$$

At this flight condition, the short period damping (ζ_{sp}) and frequency (ω_{sp}) requirements are:

$$0.35 < \zeta_{sp} \leq 1.3 \quad (12)$$

and

$$3.29 < \omega_{sp} \leq 11.8 \quad (13)$$

In complex plane, these constraints impose regional pole constraints shown in Figure 2.

Table- 1

Design Variables	ω_{sp}	ζ_{sp}
Q, R	4.5078	0.4789
\bar{Q}, \bar{R}	6.4458	0.5316
Desired	[3.29, 11.8]	[0.35, 1.3]

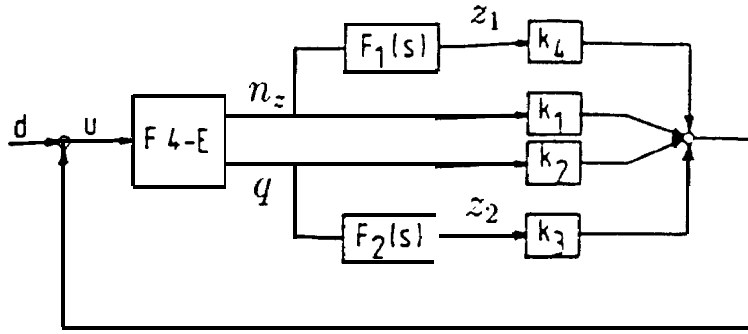

Figure 1: Control Law Structure [Ref 2] with Filters $F_1(s) = \frac{1}{s+\tau_1}$ and $F_2(s) = \frac{s+\tau_2}{s+\tau_3}$

$$\dot{z}_1 = -\tau_1 z_1 + n_z \quad (5)$$

$$\dot{z}_2 - \dot{q} = -\tau_3 z_2 + \tau_2 q \quad (6)$$

From the aircraft dynamical equations 1, substituting for \dot{q} , we have

$$\dot{z}_2 = a_{21}n_z + (a_{22} + \tau_2)q + a_{23}\delta_e - \tau_3 z_2 \quad (7)$$

For the new state vector $z(t)$,

$$\bar{x}(t) = [x(t), z_1(t), z_2(t)]'$$

the state space equations become,

$$\dot{\bar{x}}(t) = \bar{A}\bar{x}(t) + \bar{b}\bar{u}(t) \quad (8)$$

where,

$$\bar{A} = \begin{bmatrix} a_{11} & a_{12} & a_{13} & 0 & 0 \\ a_{21} & a_{22} & a_{23} & 0 & 0 \\ 0 & 0 & -14 & 0 & 0 \\ 1 & 0 & 0 & -\tau_1 & 0 \\ a_{21} & (a_{22} + \tau_2) & a_{23} & 0 & -\tau_3 \end{bmatrix}$$

$$\bar{b} = \begin{bmatrix} b_1 \\ 0 \\ 14 \\ 0 \\ 0 \end{bmatrix}$$

It can be verified that for these dynamic compensators, the system in equation 8 is completely controllable. Thus the control law

$$\bar{u}(t) = -\bar{R}^{-1}\bar{b}'\bar{P}\bar{x}(t) + r(t) \quad (9)$$

minimizes the performance index

$$\bar{J} = \int_0^{\infty} \{\bar{x}'\bar{Q}\bar{x} + \bar{u}'\bar{R}\bar{u}\} dt \quad (10)$$

and satisfies the algebraic riccati equation

$$\bar{A}'\bar{P} - \bar{P}\bar{b}\bar{R}^{-1}\bar{b}'\bar{P} + \bar{P}\bar{A} + \bar{Q} = 0 \quad (11)$$

With the above formulations, we shall now present the closed loop eigenvalues for various values of the design parameters. The design parameters for J are obviously the weighting matrices Q and R . However, note that the performance index \bar{J} is significantly influenced by the other design parameters τ_1, τ_2 , and τ_3 , in addition to Q and \bar{R} . The next section presents the simulation results.

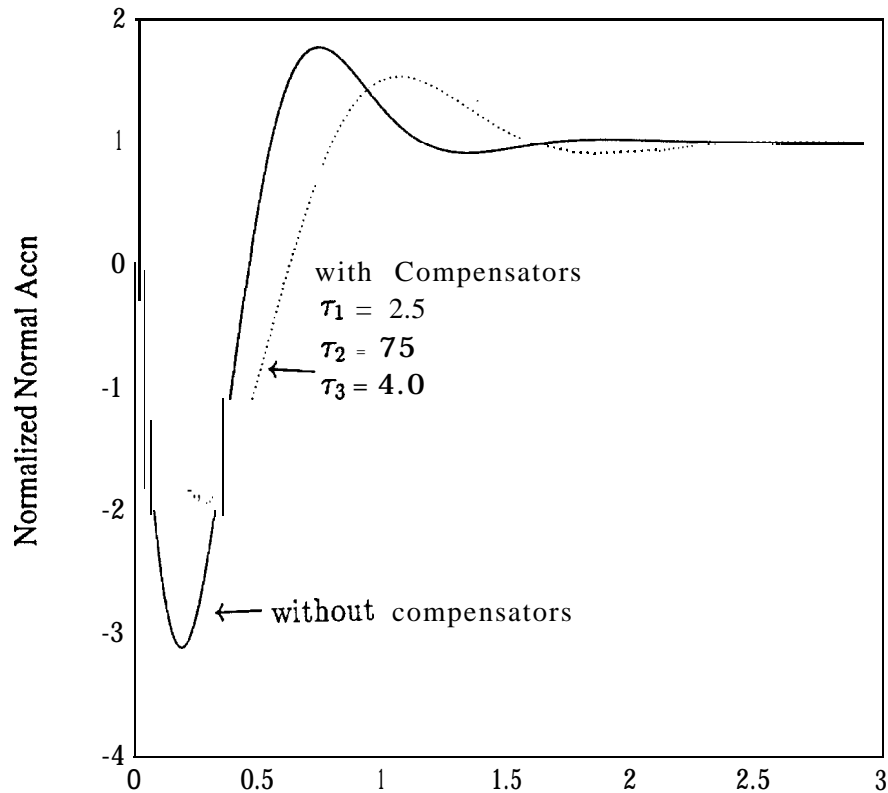

Figure 3: Time response plots due to step input

The weighting matrices $Q = 1_3$ and $R = 10^4$ as well as the weighting matrices $\bar{Q} = 1_3$ and $\bar{R} = 10^4$ provide the acceptable closed loop poles [see Table 1].

However, what needs to be observed is the time response plots (due to step input) shown in Figure 3. We observe that the normal acceleration at the sensor location is nonminimal. Moreover, the peak accelerations are significantly reduced with dynamic compensators (about 50%).

Acknowledgements:

This work is partially supported by grant from the NASA Center of Research of Excellence at NC A&T State University under grant # NAGW-2924. The authors wish to thank the NASA-CORE administration.

References:

1. "Flying Qualities of Piloted Airplanes," *MIL-F-8785B(ASG)*, Aug 7, 1969
2. S.N. Franklin and J. Ackerman, "Robust Flight Control:A Design Example," *Journal of Guidance, Control, and Dynamics*, v 4, n 6, 1981, pp 597.
3. Y. Ochi and K. Kanai, "Pole Placement in Optimal Regulator by Continuous Pole-Steering," *Journal of Guidance, Control, and Dynamics*, v 18, n 6, 1995, pp 1253-1258
4. H. Peng and M. Tomizuka, "Preview Control for Vehicle Lateral Guidance in Highway Automation: *Journal of Dynamic systems, Measurement and Control*, v 115, 1993, pp 679-686
5. CR. Ashokkumar, "Robust Optimal Compensators with Tight Control Philosophy: Rep. GCD/CRA/2, NASA Center of Research Excellence, North Carolina A & T State University, Greensboro, NC