

NASA/TM—2001-210569



529409

60P

TR11N/33

2001 074 931

# Baseline Testing of the EV Global E-Bike

Dennis J. Eichenberg, John S. Kolacz, and Paul F. Tavernelli  
Glenn Research Center, Cleveland, Ohio

---

January 2001

## The NASA STI Program Office . . . in Profile

Since its founding, NASA has been dedicated to the advancement of aeronautics and space science. The NASA Scientific and Technical Information (STI) Program Office plays a key part in helping NASA maintain this important role.

The NASA STI Program Office is operated by Langley Research Center, the Lead Center for NASA's scientific and technical information. The NASA STI Program Office provides access to the NASA STI Database, the largest collection of aeronautical and space science STI in the world. The Program Office is also NASA's institutional mechanism for disseminating the results of its research and development activities. These results are published by NASA in the NASA STI Report Series, which includes the following report types:

- **TECHNICAL PUBLICATION.** Reports of completed research or a major significant phase of research that present the results of NASA programs and include extensive data or theoretical analysis. Includes compilations of significant scientific and technical data and information deemed to be of continuing reference value. NASA's counterpart of peer-reviewed formal professional papers but has less stringent limitations on manuscript length and extent of graphic presentations.
- **TECHNICAL MEMORANDUM.** Scientific and technical findings that are preliminary or of specialized interest, e.g., quick release reports, working papers, and bibliographies that contain minimal annotation. Does not contain extensive analysis.
- **CONTRACTOR REPORT.** Scientific and technical findings by NASA-sponsored contractors and grantees.

- **CONFERENCE PUBLICATION.** Collected papers from scientific and technical conferences, symposia, seminars, or other meetings sponsored or cosponsored by NASA.
- **SPECIAL PUBLICATION.** Scientific, technical, or historical information from NASA programs, projects, and missions, often concerned with subjects having substantial public interest.
- **TECHNICAL TRANSLATION.** English-language translations of foreign scientific and technical material pertinent to NASA's mission.

Specialized services that complement the STI Program Office's diverse offerings include creating custom thesauri, building customized data bases, organizing and publishing research results . . . even providing videos.

For more information about the NASA STI Program Office, see the following:

- Access the NASA STI Program Home Page at <http://www.sti.nasa.gov>
- E-mail your question via the Internet to [help@sti.nasa.gov](mailto:help@sti.nasa.gov)
- Fax your question to the NASA Access Help Desk at 301-621-0134
- Telephone the NASA Access Help Desk at 301-621-0390
- Write to:  
NASA Access Help Desk  
NASA Center for AeroSpace Information  
7121 Standard Drive  
Hanover, MD 21076

NASA/TM—2001-210569



# Baseline Testing of the EV Global E-Bike

Dennis J. Eichenberg, John S. Kolacz, and Paul F. Tavernelli  
Glenn Research Center, Cleveland, Ohio

National Aeronautics and  
Space Administration

Glenn Research Center

---

January 2001

Trade names or manufacturers' names are used in this report for identification only. This usage does not constitute an official endorsement, either expressed or implied, by the National Aeronautics and Space Administration.

Available from

NASA Center for Aerospace Information  
7121 Standard Drive  
Hanover, MD 21076  
Price Code: A04

National Technical Information Service  
5285 Port Royal Road  
Springfield, VA 22100  
Price Code: A04

Available electronically at <http://gltrs.grc.nasa.gov/GLTRS>

## BASELINE TESTING OF THE EV GLOBAL E-BIKE

Dennis J. Eichenberg, John S. Kolacz, and Paul F. Tavernelli  
National Aeronautics and Space Administration  
Glenn Research Center  
Cleveland, Ohio 44135

### SUMMARY

The NASA John H. Glenn Research Center initiated baseline testing of the EV Global E-Bike as a way to reduce pollution in urban areas, reduce fossil fuel consumption and reduce operating costs for transportation systems. The work was done under the Hybrid Power Management (HPM) Program, which includes the Hybrid Electric Transit Bus (HETB). The E-Bike is an inexpensive approach to advance the state of the art in hybrid technology in a practical application. The project transfers space technology to terrestrial use via non-traditional partners, and provides power system data valuable for future space applications. The E-Bike is a state of the art, ground up, hybrid electric bicycle. Unique features of the vehicle's power system include the use of an efficient, 400 watt, electric hub motor, and a 7-speed derailleur system that permits operation as fully electric, fully pedal, or a combination of the two. Other innovative features, such as regenerative braking through ultracapacitor energy storage, are planned. Regenerative braking recovers much of the kinetic energy of the vehicle during deceleration. A description of the E-bike, the results of performance testing, and future vehicle development plans is the subject of this report. The report concludes that the E-Bike provides excellent performance, and that the implementation of ultracapacitors in the power system can provide significant performance improvements.

### INTRODUCTION

The NASA Glenn Research Center initiated baseline testing of the EV Global E-Bike as an excellent opportunity to transfer technology from the aerospace and military industries to a commercial venture. The project is seen as a way to reduce pollution in urban areas, reduce fossil fuel consumption and reduce operating costs for transportation systems.

The NASA Glenn Research Center provides overall project coordination and is responsible for testing the vehicle. This includes instrumenting the vehicle and developing instrumentation and control programs. Wherever practical, off-the-shelf components have been integrated into the test configuration.

### TEST OBJECTIVES

Testing of the vehicle was performed at the NASA Glenn Research Center. Of particular interest are the following characteristics: range, vehicle speed, acceleration time, and performance over stop-and-go driving schedules. The performance of the various vehicle components, especially the motor, controller, energy storage system, and charger are also of interest.

## TEST VEHICLE DESCRIPTION

The E-Bike is a state of the art, ground up, hybrid electric bicycle. The vehicle is shown in Figs. 1 and 2 and described in detail in Appendix A. The E-Bike is a parallel hybrid vehicle as shown in Fig. 3. As a parallel hybrid vehicle, power is provided to the drive wheel from an internal electric hub motor, or through the pedals via a 7-speed derailleur, or a combination of the two.

The energy storage system consists of two 12 volt, 12-amp hour sealed lead acid, deep discharge batteries to store electrical energy. The battery charger is built into the battery pack. The charger is rated at 24 volts, 3 amps DC. The complete battery pack including the charger is shown in Fig. 4. The battery pack is quickly removed from the vehicle if so desired. This permits the quick installation of another battery pack, as well as charging of the battery pack outside of the vehicle.

The electric traction motor shown in Fig. 5 is a 400-Watt DC brushed electric hub motor. This is a direct drive system with no drive train losses. A pulse width modulated motor controller allows for efficient speed control over a wide speed range. The motor controller includes cruise control to maintain constant speed.

The vehicle incorporates Department of Transportation specified safety features including lights, mirror, and horn.

Fig. 1 – EV Global E-Bike on Dynamometer



Fig. 2 – EV-Global E-Bike on Dynamometer with Fairing Removed



Fig. 3 – E-Bike Schematic Diagram

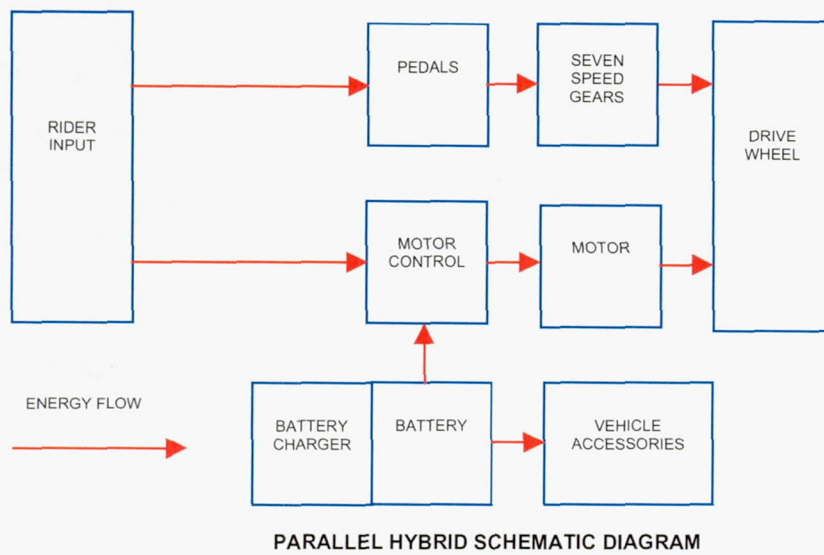

Fig. 4 – Battery Pack



Fig. 5 – Hub Motor



## INSTRUMENTATION

The E-Bike was instrumented to measure vehicle speed, distance, and load. These data were sent to an off-board digital data acquisition system, sampled continuously and stored on a desktop PC. Additional channels measured the battery voltage and current, as well as the following temperatures: traction motor, motor controller, battery, and the ambient temperature. These data were sent to an off-board digital data acquisition system and stored on a laptop PC. Power for the data acquisition system, was derived from the Building 86 utility system. The instrumentation configuration is described in Appendix B.

Battery charging power requirements were determined from measuring the battery charger voltage and current. The battery temperature was also monitored. These data were sent to an off-board digital data acquisition system, sampled once a minute and stored on a laptop PC.

## TEST PROCEDURES

The tests described in this report were conducted on a dynamometer at the NASA Glenn Research Center in Cleveland, Ohio. A description of the dynamometer is given in Appendix C. The tests were conducted in accordance with the test matrix provided in Appendix D.

## TEST RESULTS

### Vehicle Performance

Twenty-seven tests were conducted to determine vehicle performance, per Table 1:

**Table 1 – Performance Tests Conducted on the E-Bike**

<i>Test Number</i>	<i>Grade (%)</i>	<i>Vehicle Mode</i>	<i>Top Vehicle Speed</i>	<i>Driving Cycle</i>
1	0	Normal	5 mph	Range test.
2	0	Normal	10 mph	Range test.
3	0	Normal	Maximum	Range test.
4	+2	Normal	Maximum	Range test.
5	+4	Normal	Maximum	Range test.
6	+6	Normal	Maximum	Range test.
7	+8	Normal	Maximum	Range test.
8	0	Normal	Maximum	Acceleration test.
9	0	Economy	Maximum	Acceleration test.
10	+2	Normal	Maximum	Acceleration test.
11	+2	Economy	Maximum	Acceleration test.
12	+4	Normal	Maximum	Acceleration test.
13	+4	Economy	Maximum	Acceleration test.
14	+6	Normal	Maximum	Acceleration test.
15	+6	Economy	Maximum	Acceleration test.
16	+8	Normal	Maximum	Acceleration test.
17	+8	Economy	Maximum	Acceleration test.
18	0	Normal	Maximum	3 stops.
19	0	Economy	Maximum	3 stops.
20	+2	Normal	Maximum	3 stops.
21	+2	Economy	Maximum	3 stops.
22	+4	Normal	Maximum	3 stops.
23	+4	Economy	Maximum	3 stops.
24	+6	Normal	Maximum	3 stops.
25	+6	Economy	Maximum	3 stops.
26	+8	Normal	Maximum	3 stops.
27	+8	Economy	Maximum	3 stops.
28	N/A	N/A	N/A	Battery charging test.

A similar set of plots have been included in Appendix E for each of the vehicle tests:

- a. Vehicle speed and vehicle power vs. elapsed time.
- b. Vehicle battery voltage, current, and power vs. elapsed time.
- c. Component temperatures vs. elapsed time.

The battery-charging plot indicates the charging ac voltage, current and power, as well as the ambient and battery temperatures.

A summary of the test results is shown in Table 2 at the end of this section.

## Maximum Speed

The maximum speed of the vehicle was measured to be 12.1 mph with no grade under full power. Figure 6 indicates the maximum speeds achieved at various grades, as well as the various powers that were obtained.

Fig. 6 – Maximum Speed for Various Grades

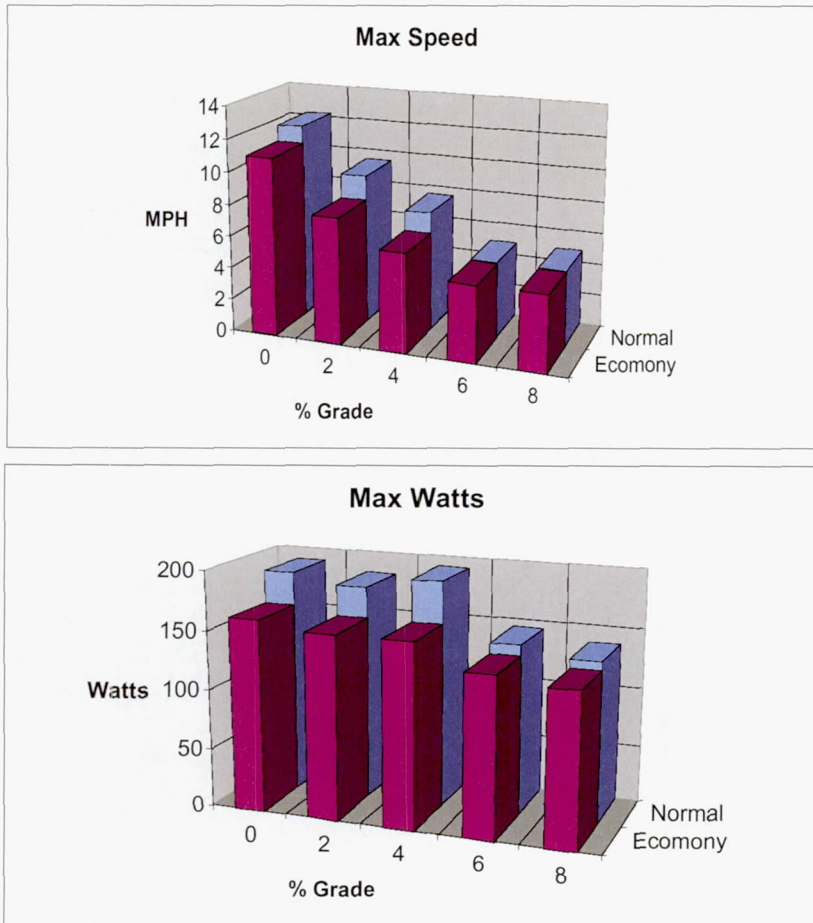

## Acceleration

The average acceleration,  $a_n$ , of the vehicle is computed as a change in vehicle speed as a function of time.

$$a_n = \frac{V_n - V_{n-1}}{t_n - t_{n-1}}$$

Acceleration times are given in Table 2.

## Range

The range of the vehicle was determined from the dynamometer tests under full electric operation. This yields a range of 34.8 miles for no grade in the normal mode with an initial speed of 5 mph. As seen in Figure 8, there is some inconsistency in range at various grades due to the effects of power and speed upon the vehicle control system.

Fig. 7 – Range in Normal Mode with 0% Grade

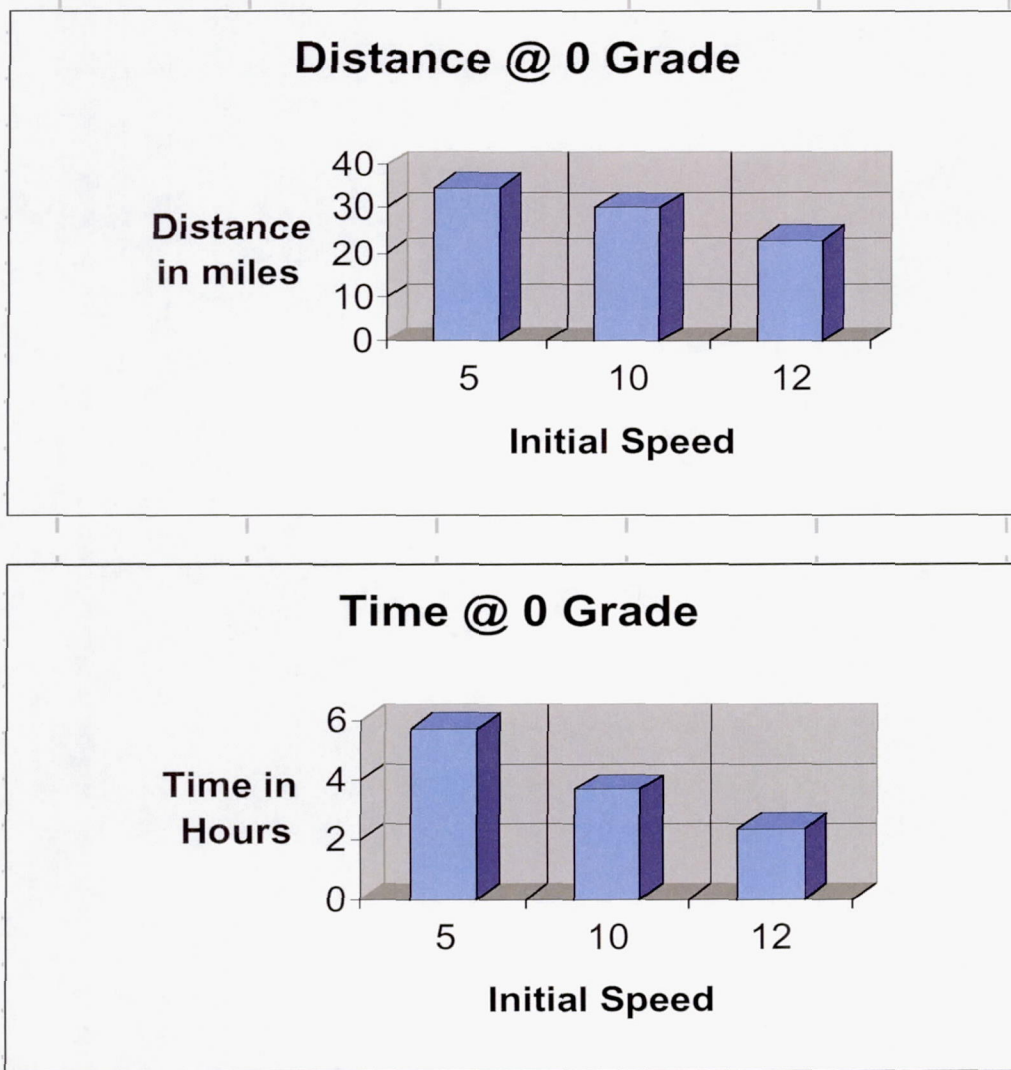
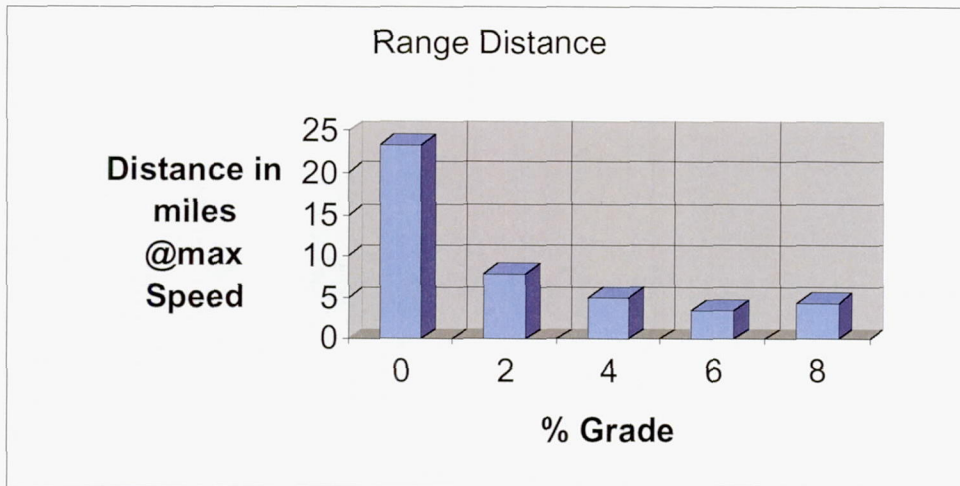

Fig. 8 – Range in Normal Mode with Various Grades



## Summary

An overall summary of the vehicle testing is shown in Table 2.

**Table 2 – Summary of Test Results for the EV Global E-Bike**

Parameter	Test Conditions	Test Results	Remarks
Range			
5 mph Initial Speed	0% Grade, Normal Mode	34.8 miles 5.70 hrs	
10 mph Initial Speed	0% Grade, Normal Mode	30.0 miles 3.68 hrs	
12 mph Initial Speed	0% Grade, Normal Mode	23.2 miles 2.35 hrs	Maximum speed.
Top Speed	0% Grade, Normal Mode	12.1 mph	
Acceleration Times			
5 mph	0% Grade, Normal Mode	1 sec	
10 mph	0% Grade, Normal Mode	8 sec	
12 mph	0% Grade, Normal Mode	15 sec	Maximum speed.
Battery Charging			Battery discharged to cutoff (18 VDC) by E-Bike.
Time	122.7 VAC Line	4.3 hrs	
Maximum AC Current	122.7 VAC Line	1.24 amps	
Maximum AC Power	122.7 VAC Line	150 watts	
Total Energy	122.7 VAC Line	0.405 kWh	

## CONCLUDING REMARKS

The EV Global E-Bike as tested and described in this report is a commercially available vehicle that is fully prepared for the mass market. The vehicle exhibited no problems under the rigorous test conditions that it was exposed to. The performance of the vehicle proved to be excellent.

The range performance of the vehicle was extraordinary. The range of 34.8 miles that was achieved with an initial speed of 5 mph with no grade is almost twice the advertised range of 20 miles. The vehicle operated for 5.7 hours under these conditions. At an initial speed of 10 mph with no grade, a range of 30.0 miles was achieved. The vehicle operated for 3.68 hours under these conditions. At maximum throttle with no grade, a range of 23.2 miles was achieved. The vehicle operated for 2.35 hours under these conditions.

The top speed of the vehicle with no grade and full throttle was 12.1 mph, which was a bit under the advertised 15-mph, but perfectly adequate for most riding, and provided excellent economy. A higher performance model with a 36-volt battery pack will be available soon, and is expected to provide a higher top speed. The acceleration of the vehicle was excellent.

The baseline testing of the E-Bike was the first step in the process. Future plans for the E-Bike calls for the testing of the vehicle with regenerative braking. Ultracapacitors will be used for regenerative braking, because of their superiority to batteries in accepting high braking currents, allowing for less usage of the mechanical brakes. A photovoltaic charging station will be assembled and tested, to permit the effective use of the E-Bike in remote locations with no dependence upon the utilities.

The E-Bike provides an inexpensive approach to advance the state of the art in hybrid technology in a practical application. The project transfers space technology to terrestrial use via non-traditional partners, and provides power system data valuable for future space applications.

## APPENDIX A

### VEHICLE SUMMARY DATA SHEET

1.0	Vehicle Manufacturer	EV Global Motors Company Los Angeles, CA
2.0	Vehicle	E-Bike Touring Model
3.0	Vehicle Configuration	Parallel Hybrid
4.0	Traction Motor	
	4.1 Traction Motor Configuration	DC brushed
	4.2 Traction Motor Power	400 watts
	4.3 Traction Motor Cooling	Air cooled
5.0	Drivetrain	
	5.1 Traction Motor Drivetrain	Direct Drive
	5.2 Pedal Drivetrain	
	5.1.1 Transmission Type	7-speed Shimano derailleur
	5.1.2 Front Chain Ring	33 teeth
	5.1.3 Rear Cluster	14, 16, 18, 20, 22, 24, 28 teeth
	5.1.4 Gear Ratio	0.42, 0.48, 0.55, 0.61, 0.67, 0.73, 0.85
	5.1.5 Crankarm	6.7 in (170 mm)
	5.1.6 Chain	_ x 3/32 x 110 L
6.0	Vehicle Dimensions	
	6.1 Wheel Base	41.8 in (1062.3 mm)
	6.2 Frame Size (center to top)	16.5 in (419 cm)
	6.3 Head Tube	6.4 in (163 mm)
	6.4 Headset Stack Height	1.30 in (33 mm)
	6.5 Headset Dimensions	25.4 mm x 34 mm x 30 mm w/seal
	6.6 Fork Steerer Tube	1-1/8 in
	6.7 Fork Travel	65 mm
	6.8 Stem 1	40 degrees, 110 mm extension
	6.9 Stem 2	28.6 mm x 25.4 mm x 150 mm with quill
	6.10 Handlebar Width	620 mm
	6.11 Handlebar Rise	30 mm, 10 degrees
	6.12 Handlebar Handle	200 mm
	6.13 Seat Post	350 mm x 27.2 mm O.D.
	6.14 Seat Post Spacer	100 mm x 27.3 I.D. x 34.9 mm O.D.
	6.15 Tires	26 x 1.95 in
	6.16 Rims	26 x 1.5 in, 14G x 36H, double wall
	6.17 Spokes	
	6.17.1 Front	266 mm, 14G stainless with brass nipples
	6.17.2 Rear	219 mm, 14G stainless with brass nipples

6.18 Bottom Bracket	127 mm cartridge
6.19 Base Curb Weight	67 lb
6.20 Total Weight (as tested)	267 lb

## 7.0 Energy Storage

### 7.1 Battery Pack

7.1.1 Configuration	Two in series with integral charger
7.1.2 Battery Type	Deep discharge, sealed lead acid
7.1.3 Battery Energy Rating	12 amp hours each
7.1.4 Battery Voltage Rating	12 volts each
7.1.5 Charger Input	115 volts ac, 60 Hz, 2 amps
7.1.6 Charger Output	24 volts dc, 3 amps
7.1.7 Dimensions	15 in x 4 in x 4 in
7.1.8 Weight	23 lb

## APPENDIX B

### DESCRIPTION OF THE INSTRUMENTATION SYSTEM

A block diagram of the instrumentation system is shown in Fig. B-1.

The vehicle dynamometer has an integral instrumentation system that monitors vehicle speed, distance, and power. These data are sampled at 3 Hz and transmitted to the desktop PC via a serial interface. The PC logs the dynamometer data.

All other measurements were obtained with a Hewlett Packard data acquisition system, sampling at 100 Hz. Type K thermocouples were used for all temperature measurements. Hall effect transducers were used for all current measurements. These data are transmitted to the laptop PC via a serial interface. The PC logs the data.

Fig. B-1 – Vehicle Instrumentation System

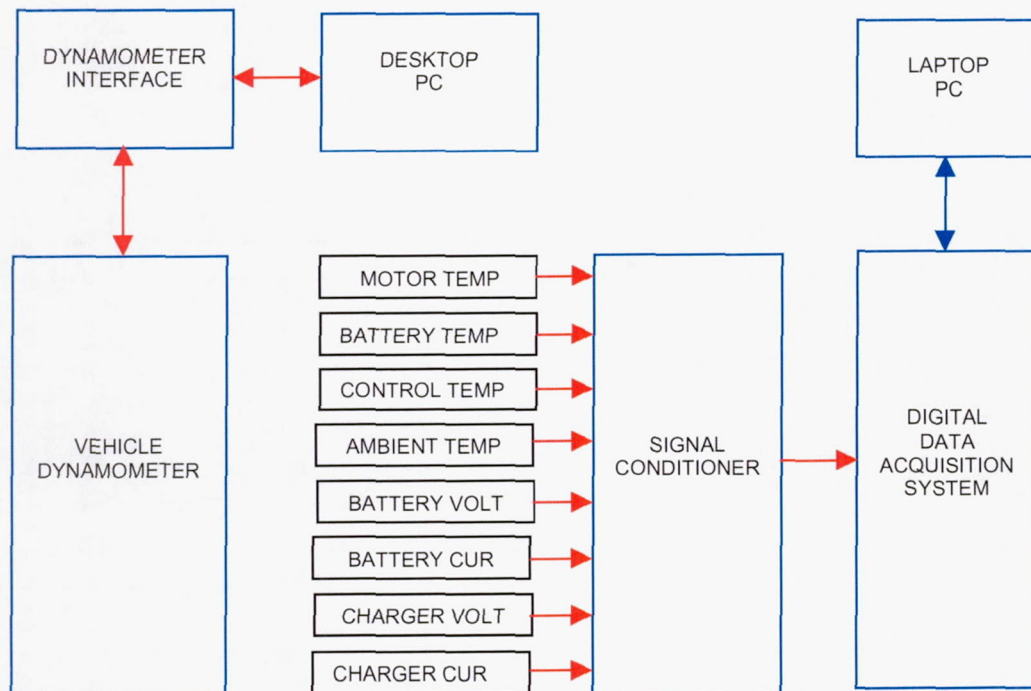

## APPENDIX C

### DESCRIPTION OF VEHICLE DYNAMOMETER

The vehicle dynamometer used to conduct the tests described in this report is the CompuTrainer Pro Challenge PC1 Model 8001. It is a high performance, microprocessor controlled, indoor dynamometer designed for bicycle use. The electronic load generator is capable of creating resistance loads from 50 to 1500 watts to simulate road grades to 15%. The dynamometer is shown in Fig. 2.

Tests documented in this report were conducted with the dynamometer programmed to meet the test matrix requirements.

## APPENDIX D

### DESCRIPTION OF TEST CYCLES

Testing of the vehicle was based on the test matrix shown in table D-1.

**Table D-1 EV Global E-Bike Test Matrix**

PARAMETER	CONDITIONS
Acceleration	To maximum speed at 0%, 2%, 4%, 6% and 8% grades in the normal and economy modes of operation.
Range	To maximum speed at 0%, 2%, 4%, 6% and 8% grades in the normal mode of operation. To 5 mph and 10 mph at 0% grade in the normal mode of operation.
Top Speed	To maximum speed at 0% grade in the normal mode of operation.
Stop	To maximum speed at 0%, 2%, 4%, 6%, and 8% grades in the normal and economy modes of operation. Three stops.
Battery Charging	From battery discharged to 18 volts, to full charge.

## APPENDIX E

### VEHICLE PERFORMANCE TEST RESULTS

A complete set of plots of the test results are included here. Table 1 identifies the tests that were conducted.

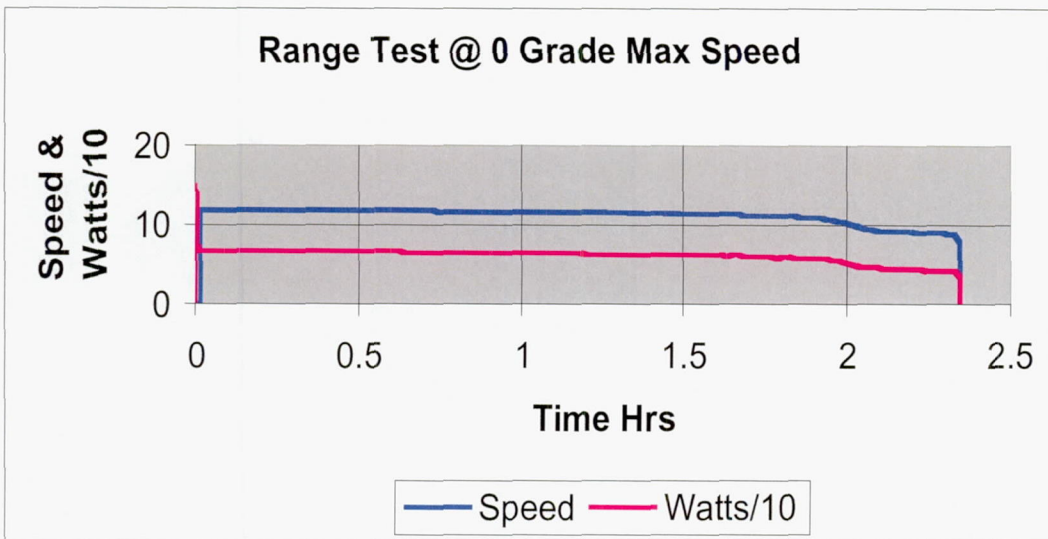
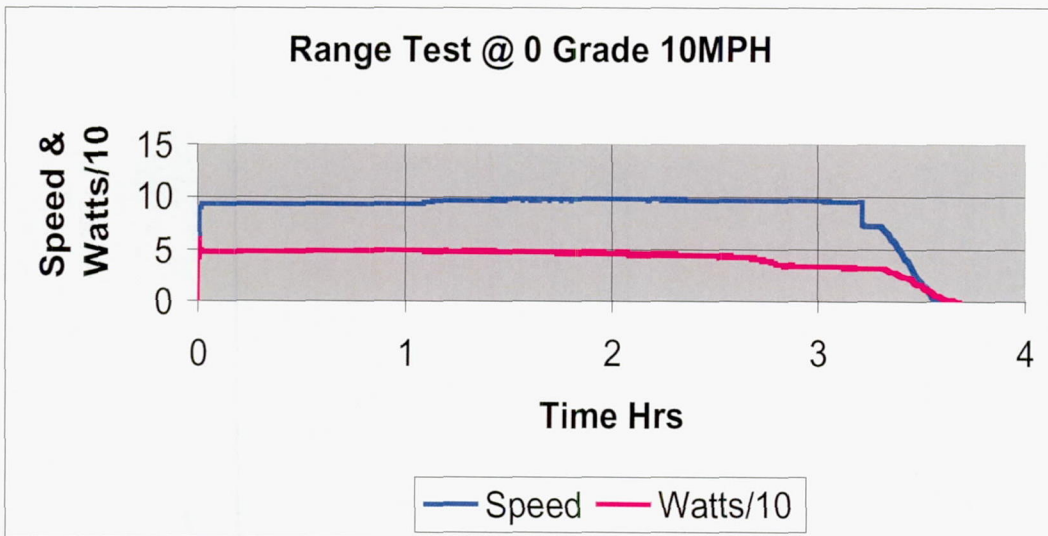
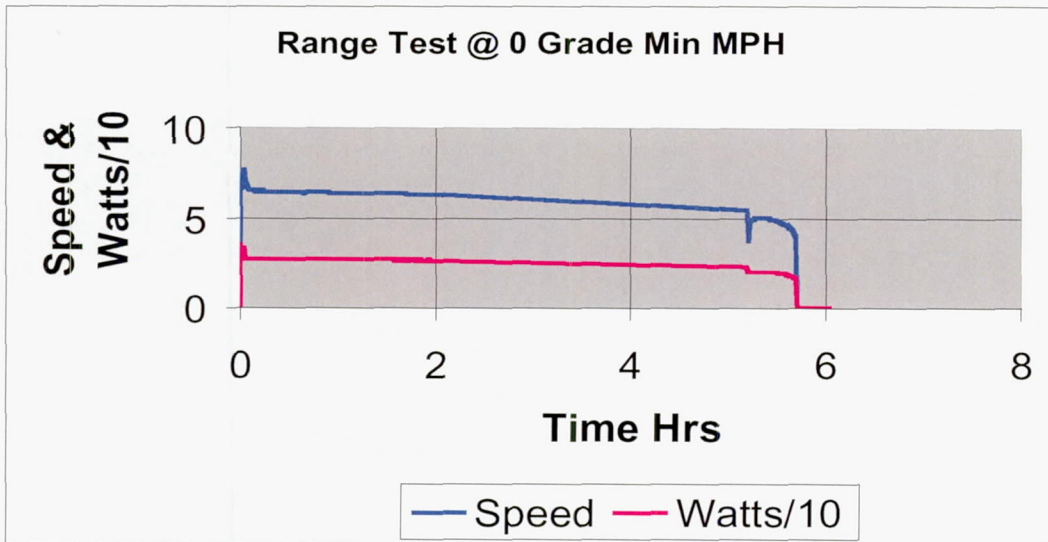

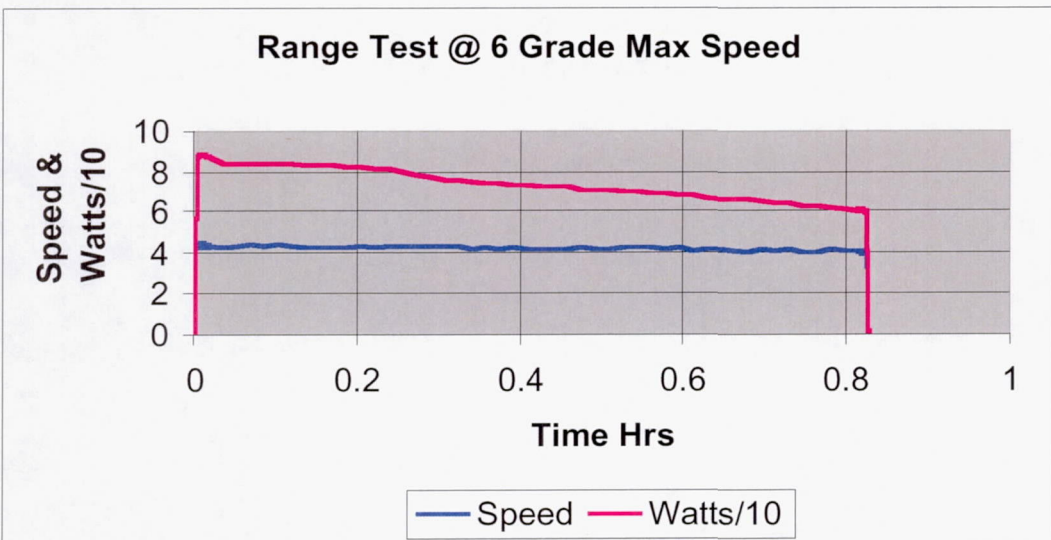
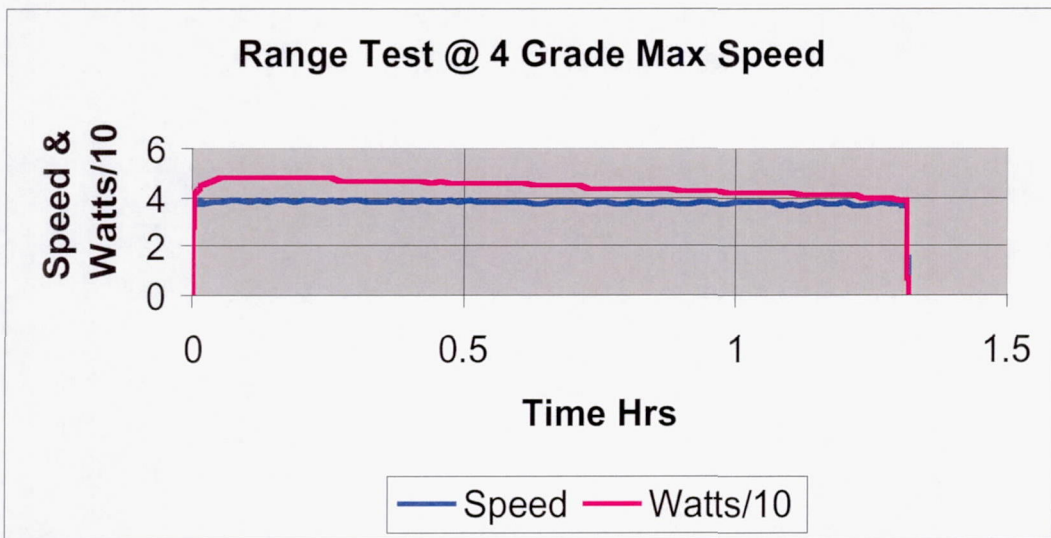
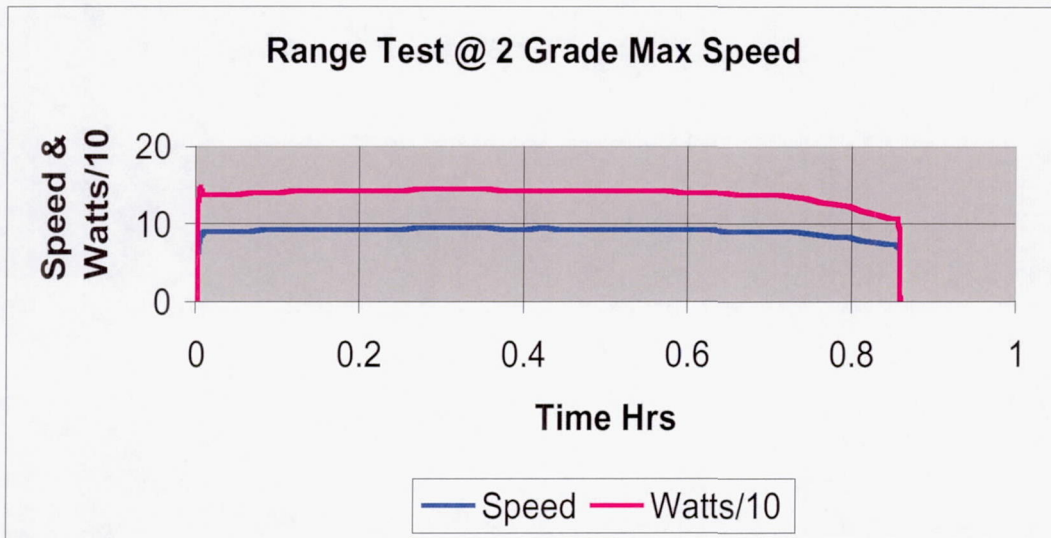

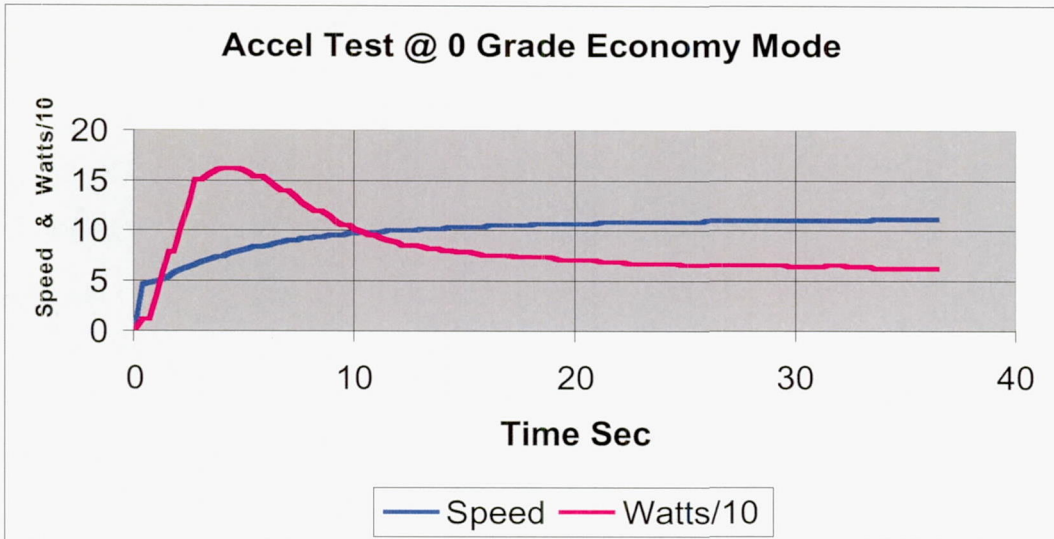
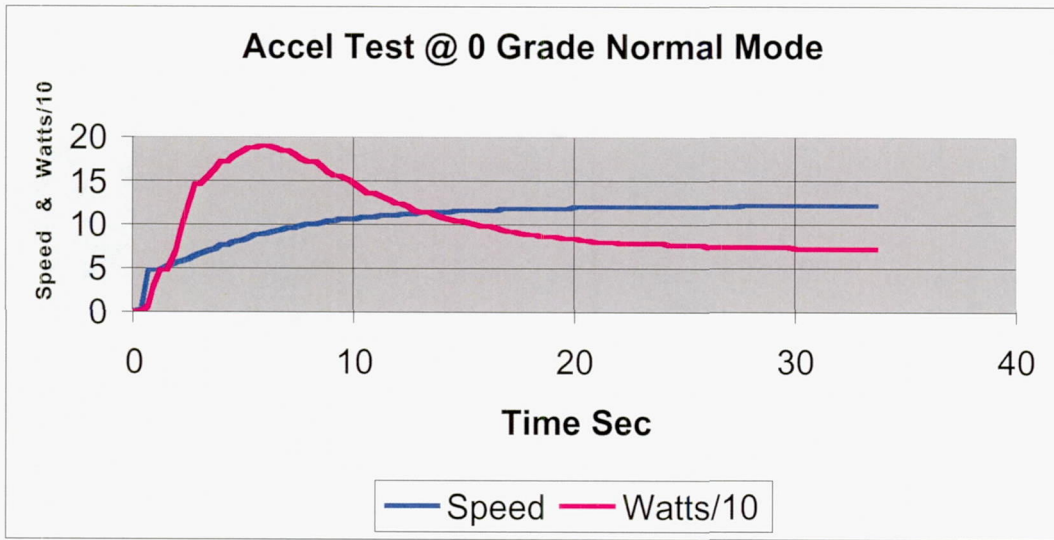
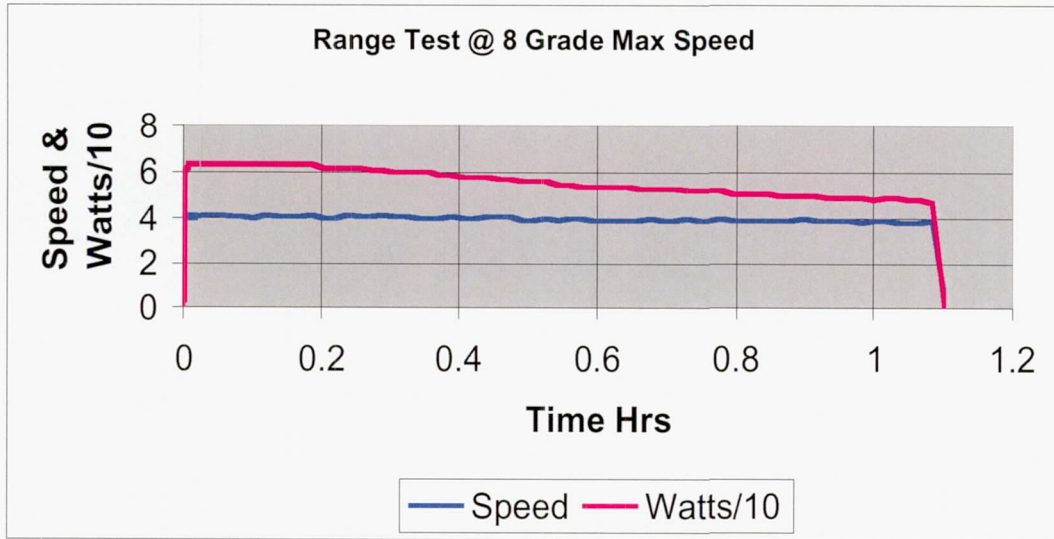

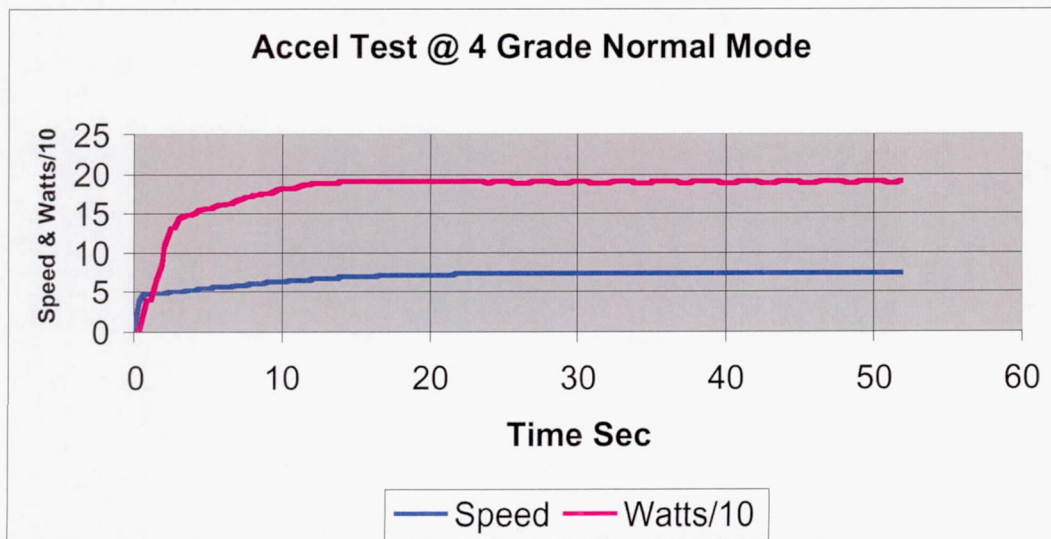
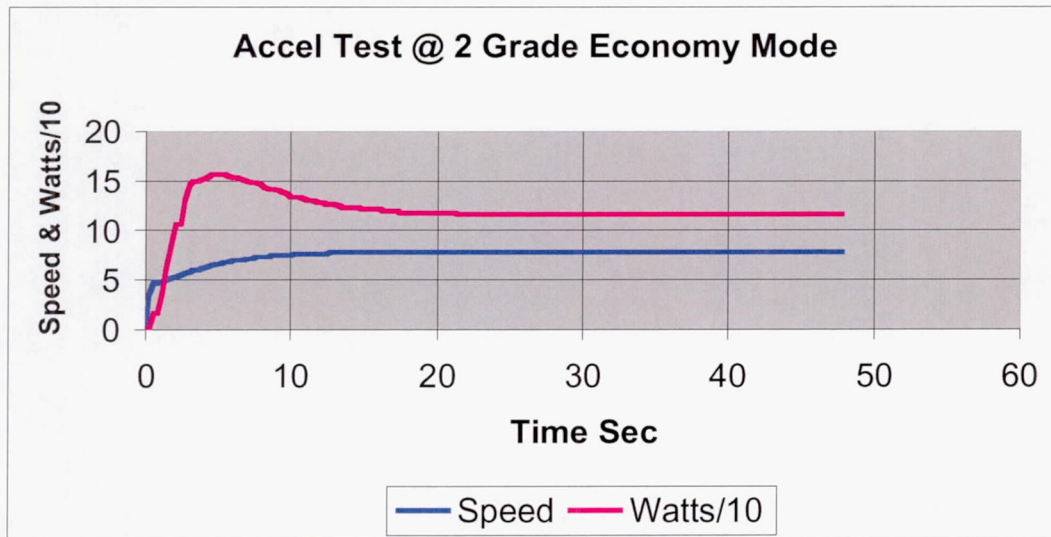
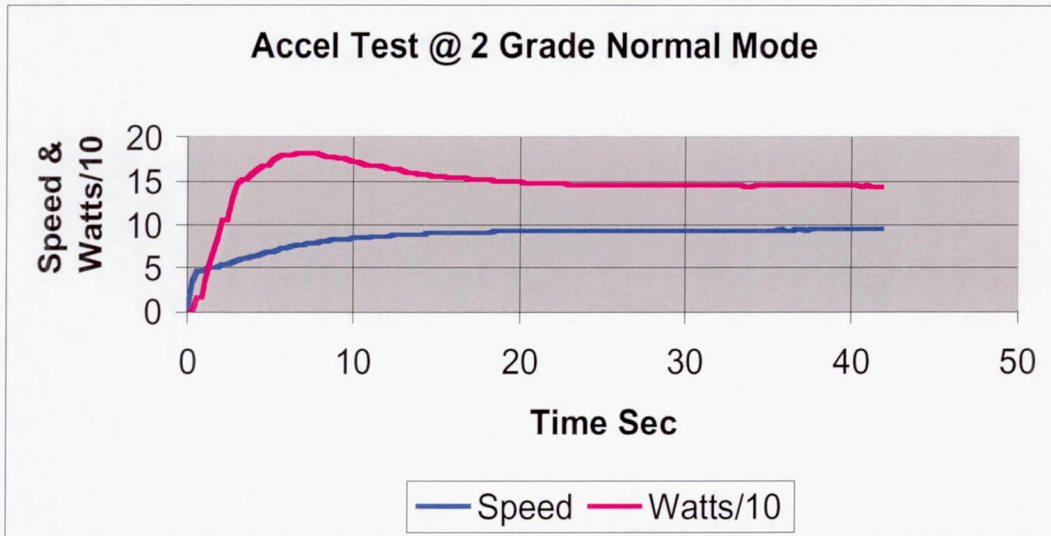

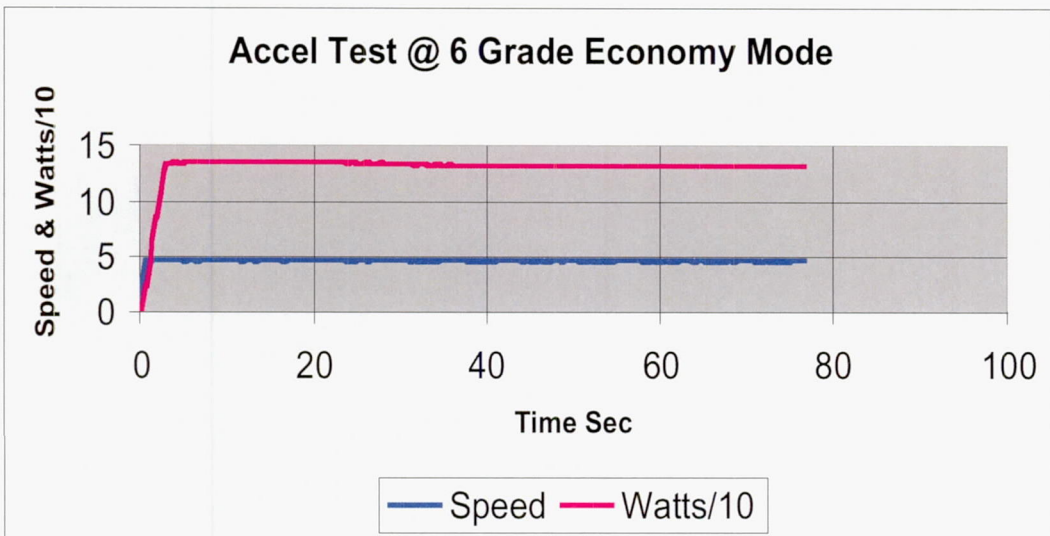
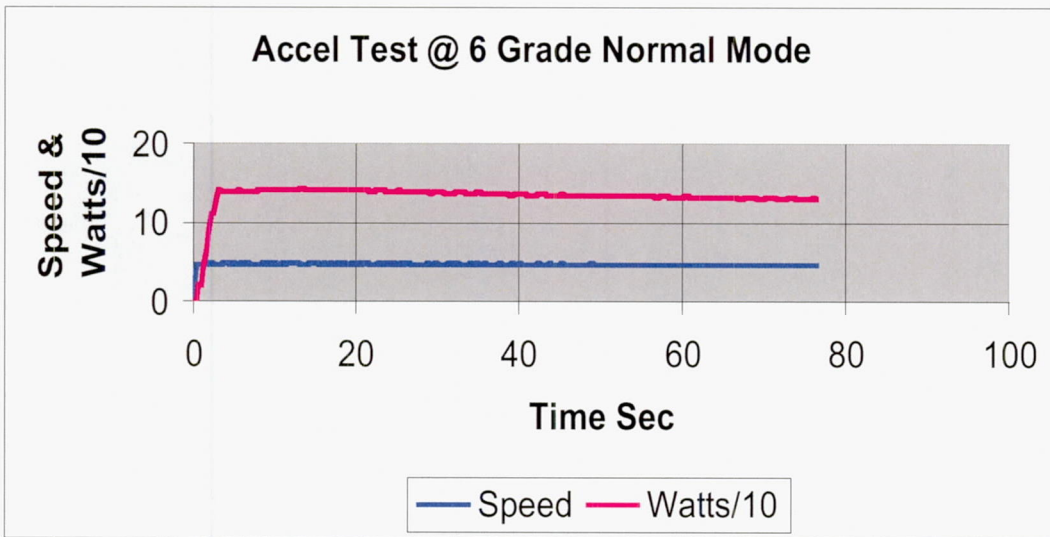
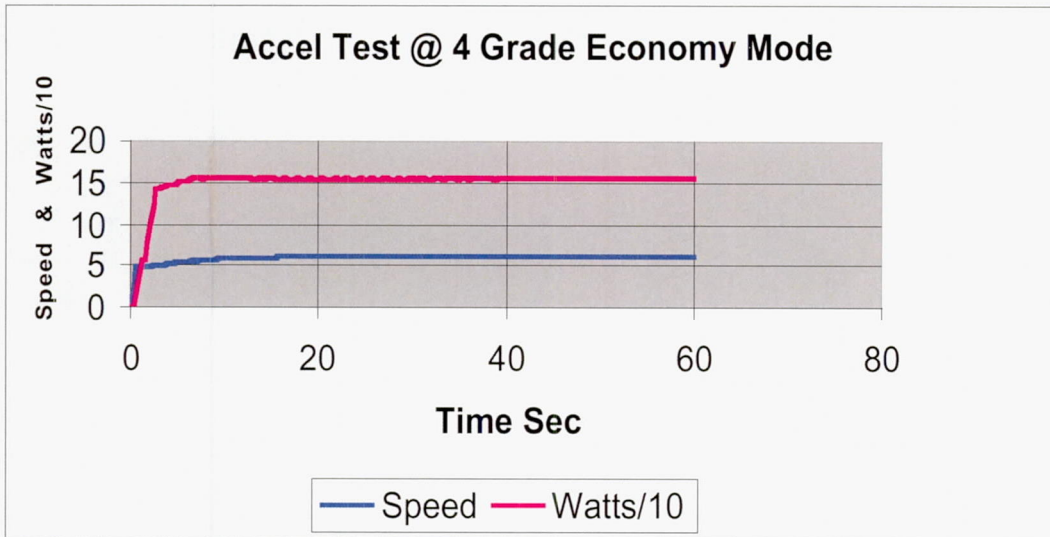

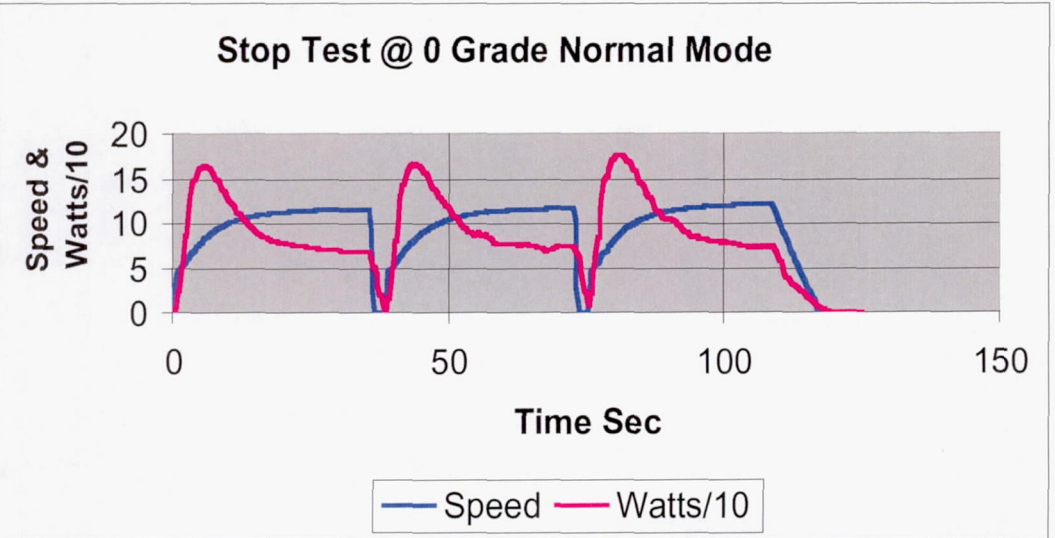
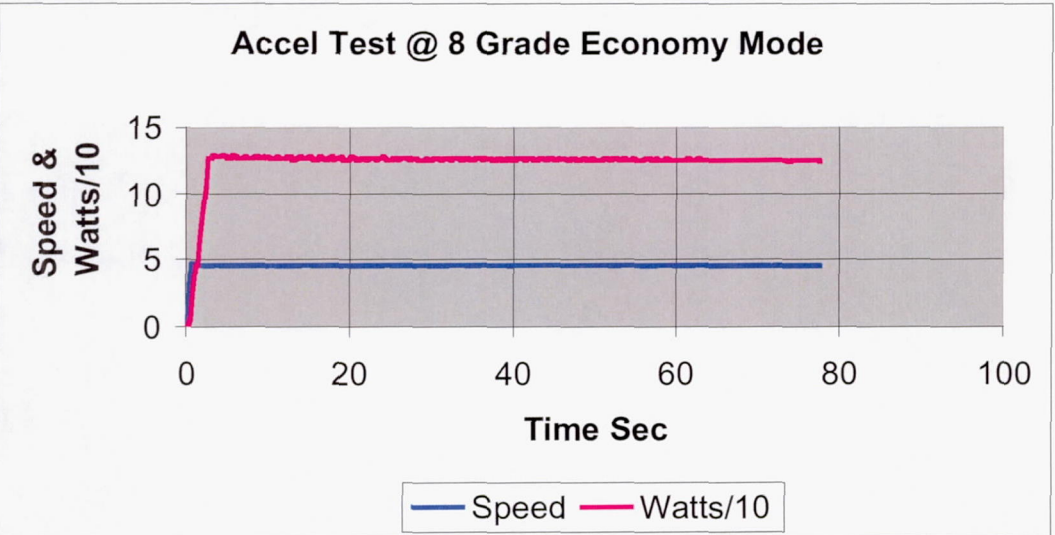
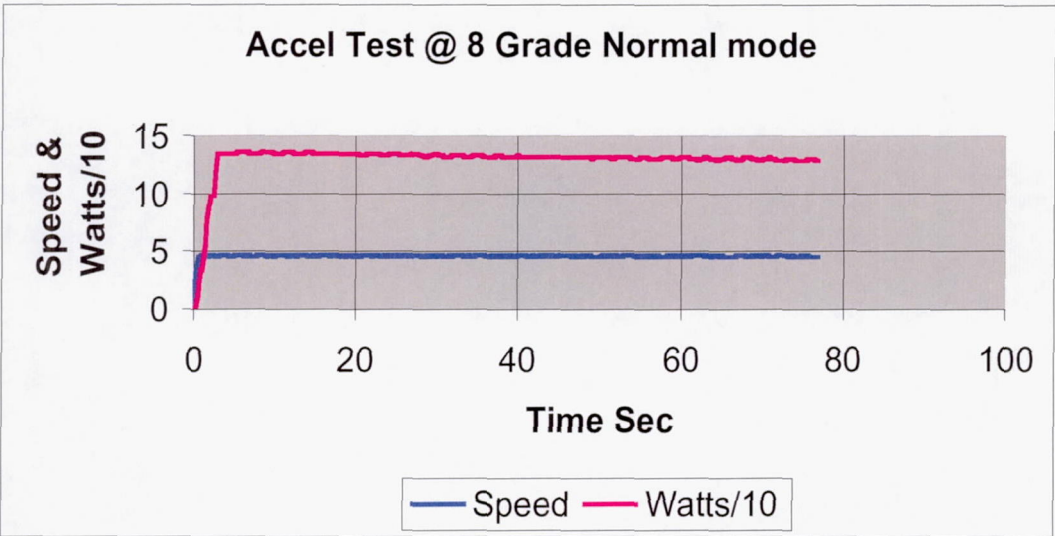

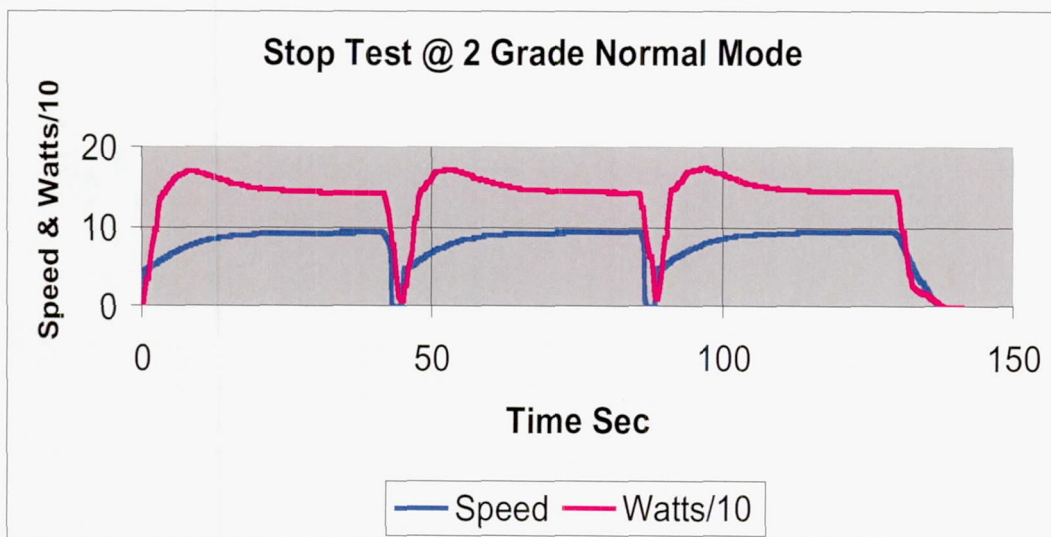
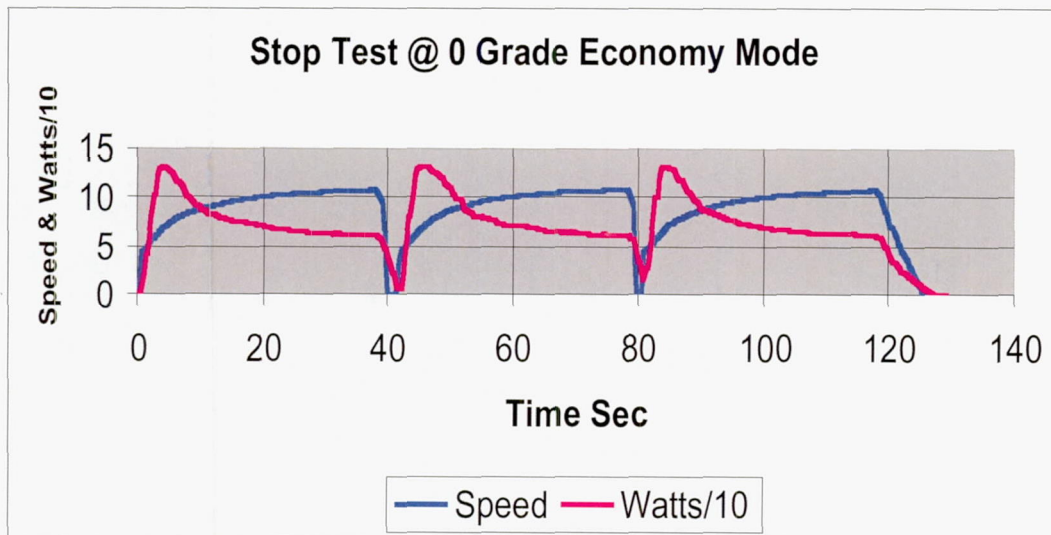

### Stop Test @ 4 Grade Normal Mode

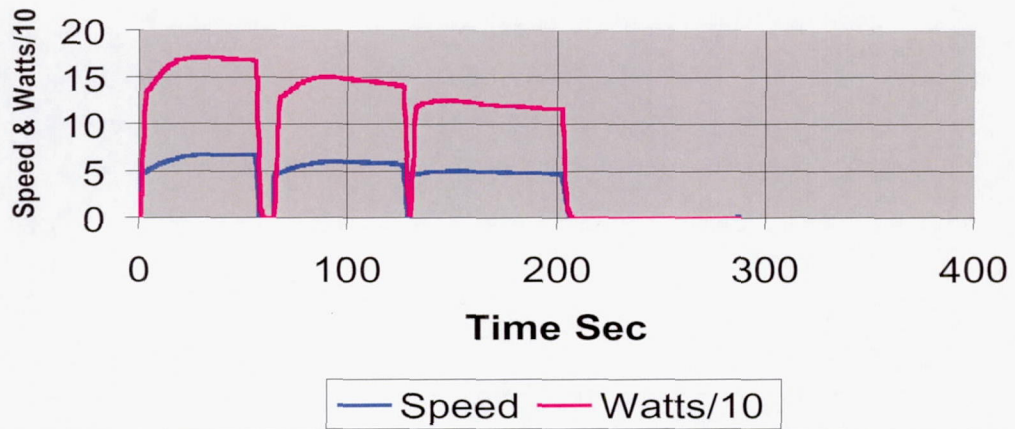

### Stop Test @ 4 Grade Economy Mode

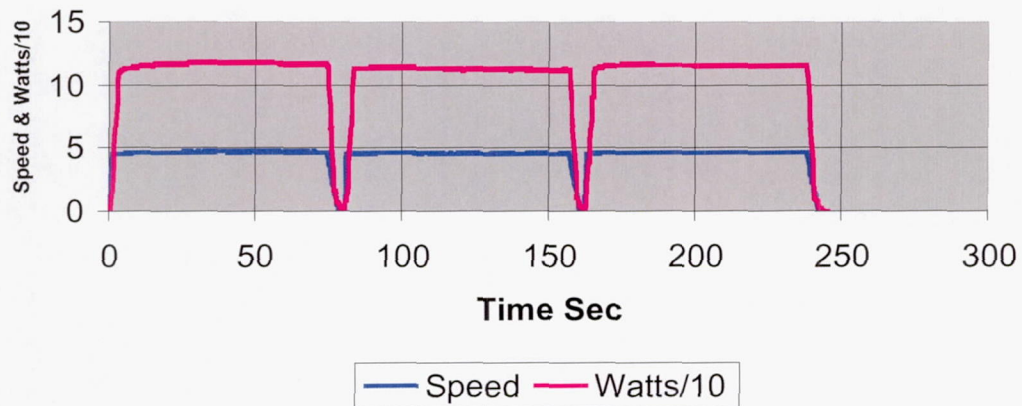

### Stop Test @ 6 Grade Normal Mode

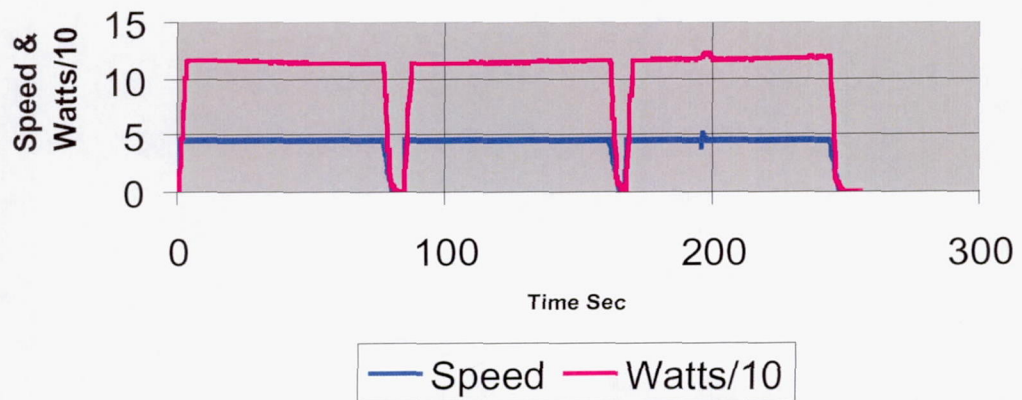

### Stop Test @ 6 Grade Economy Mode

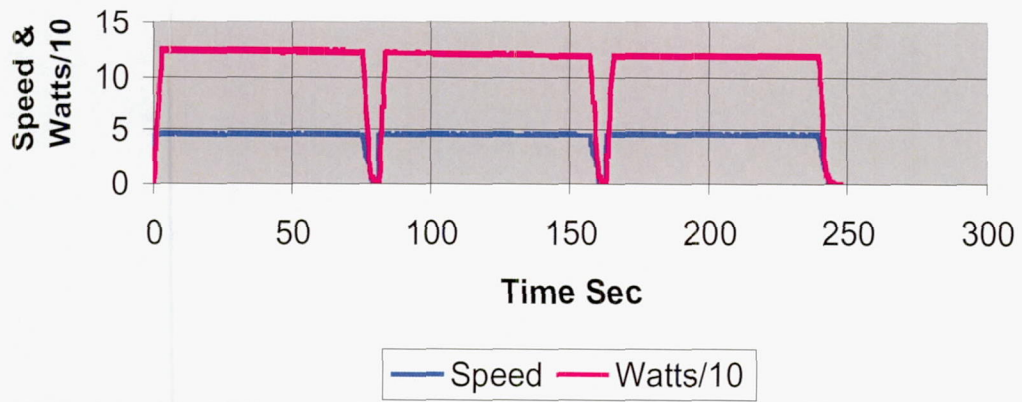

### Stop Test @ 8 Grade Normal Mode

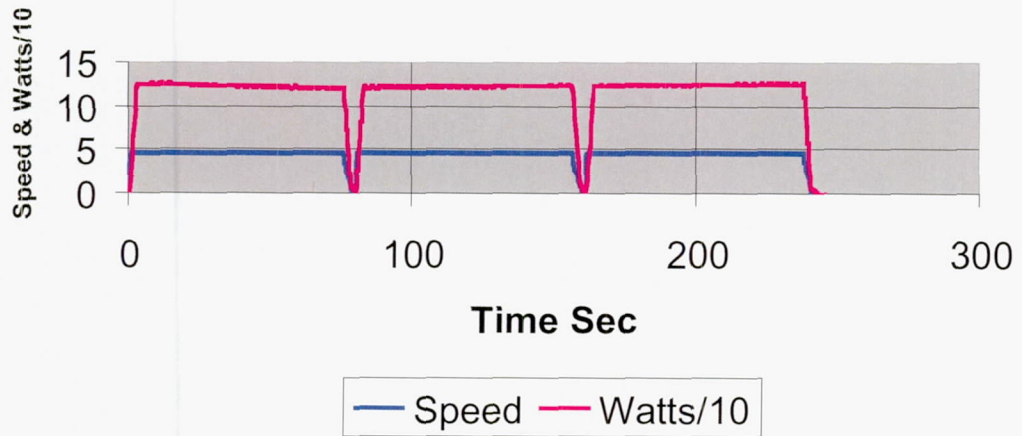

### Stop Test @ 8 Grade Economy Mode

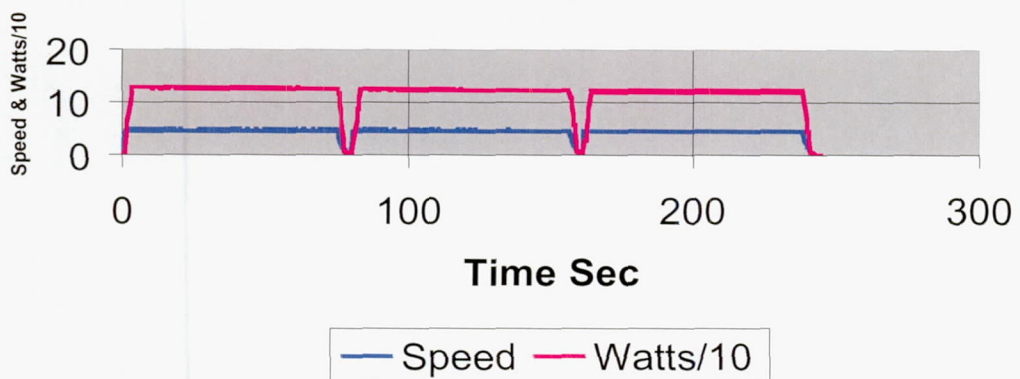

### Test 1: Range Test, 5mph Initial Speed, 0% Grade, Normal Mode

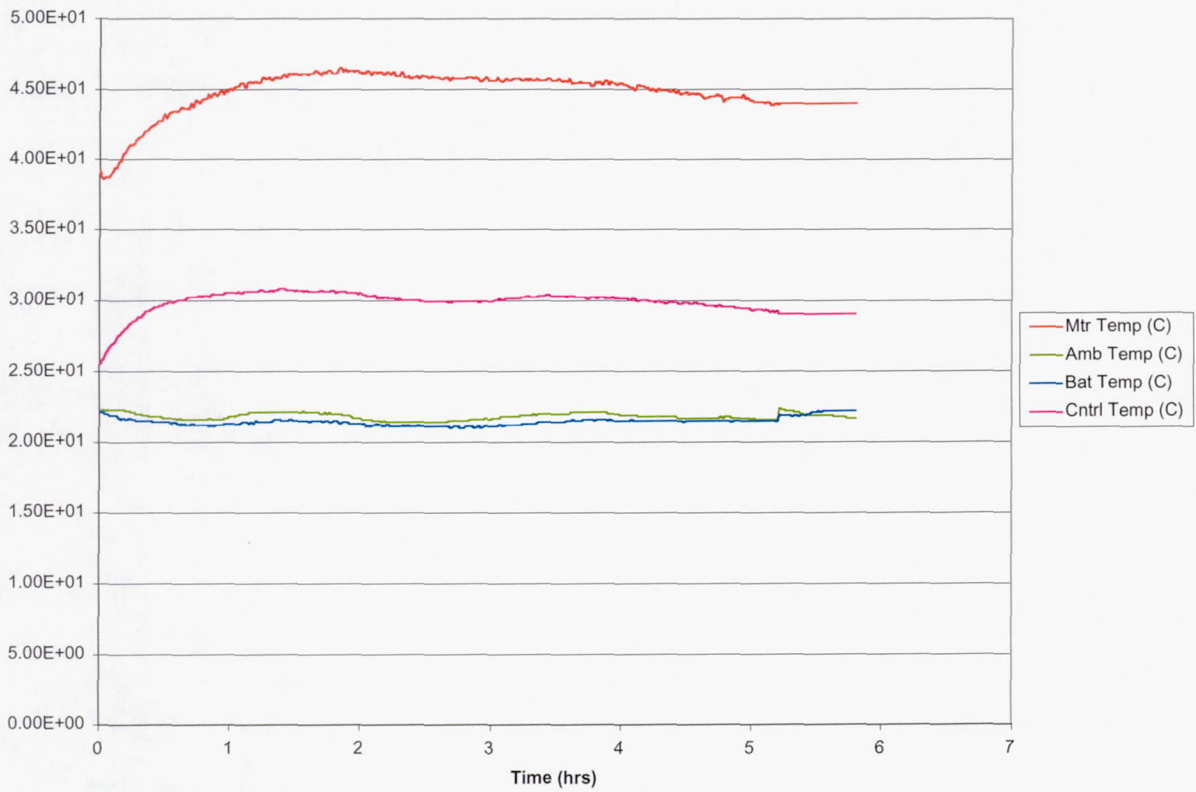
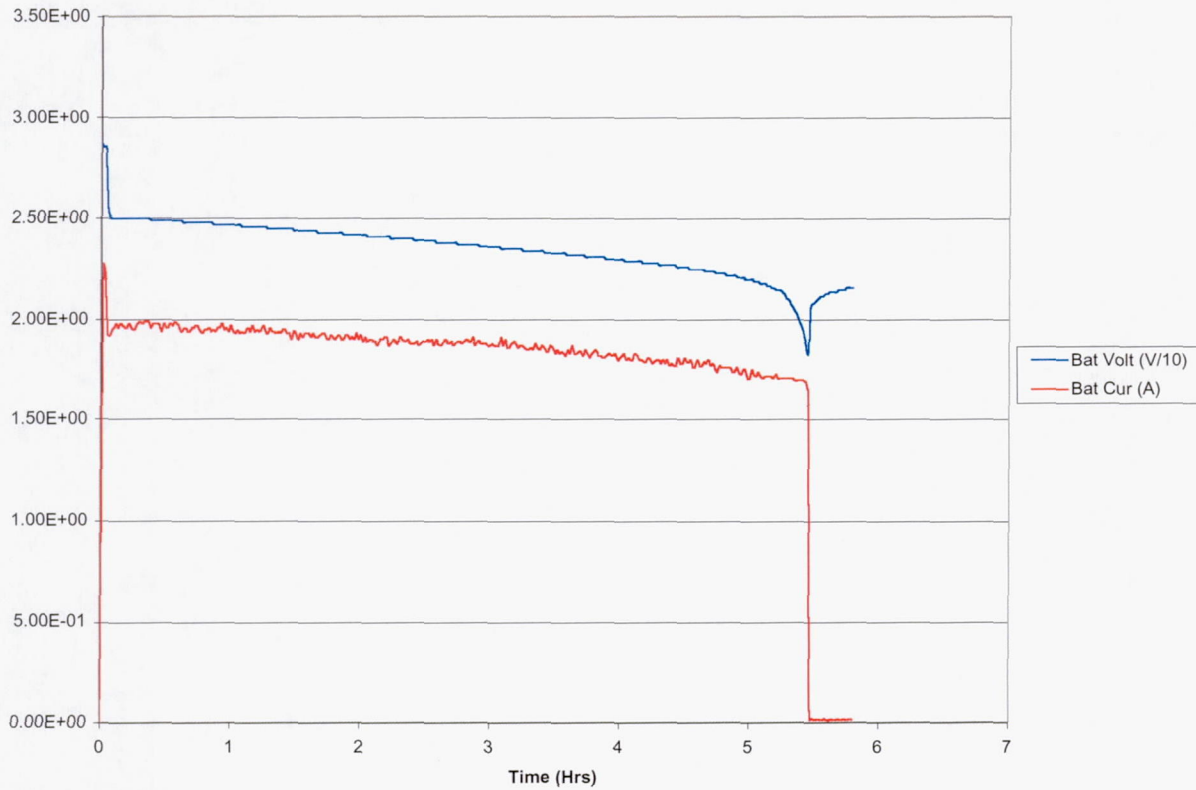

### Test 2: Range Test, 0% Grade, 10 mph Initial Speed, Normal Mode

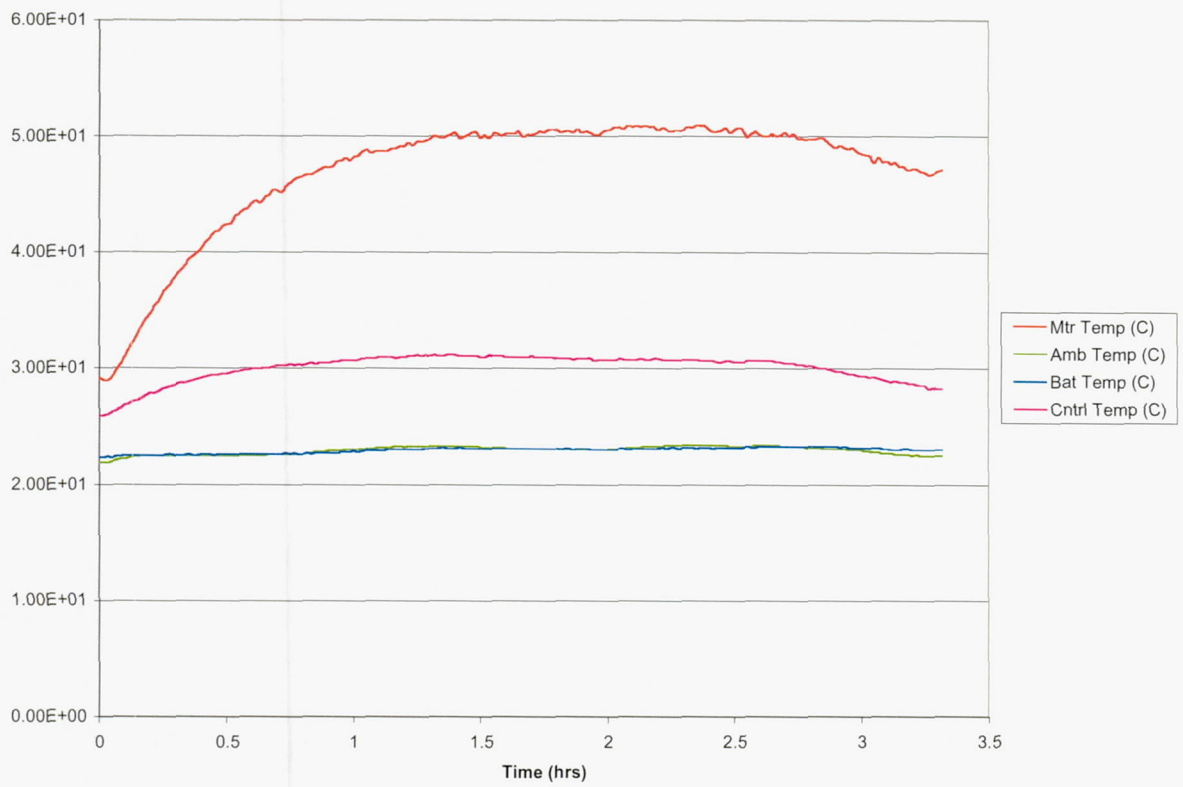
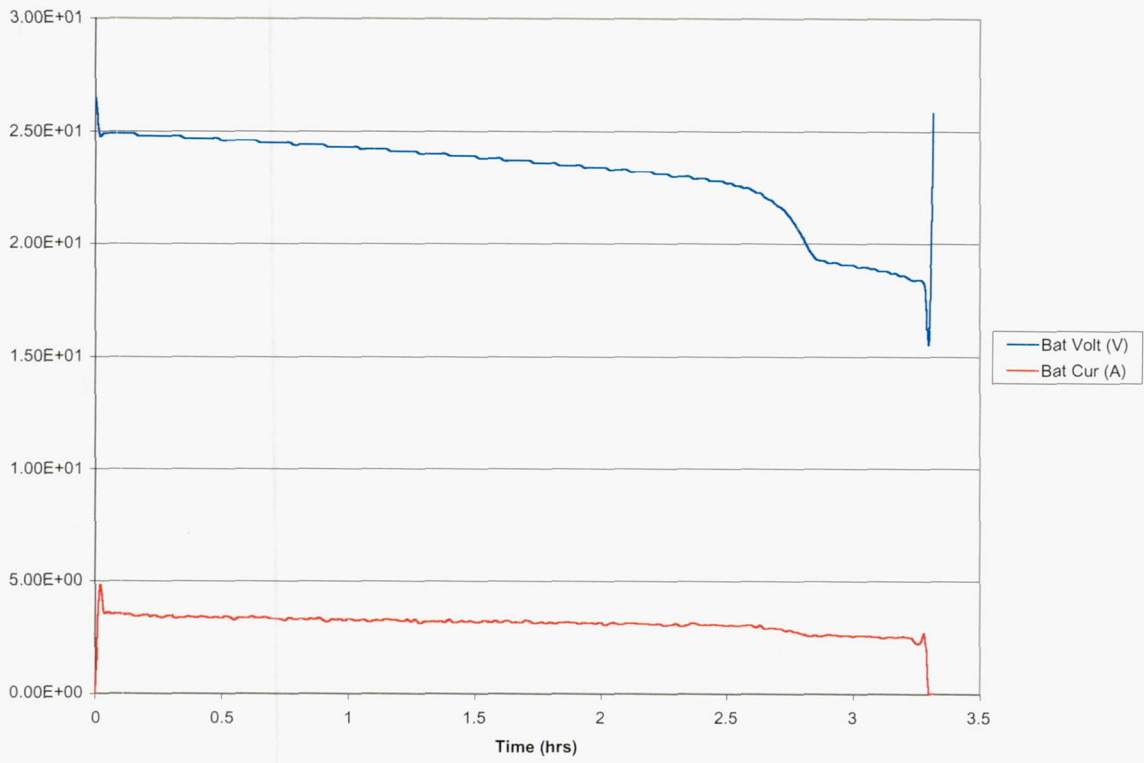

**Test 3: Range Test, 0% Grade, Maximum Initial Speed, Normal Mode**

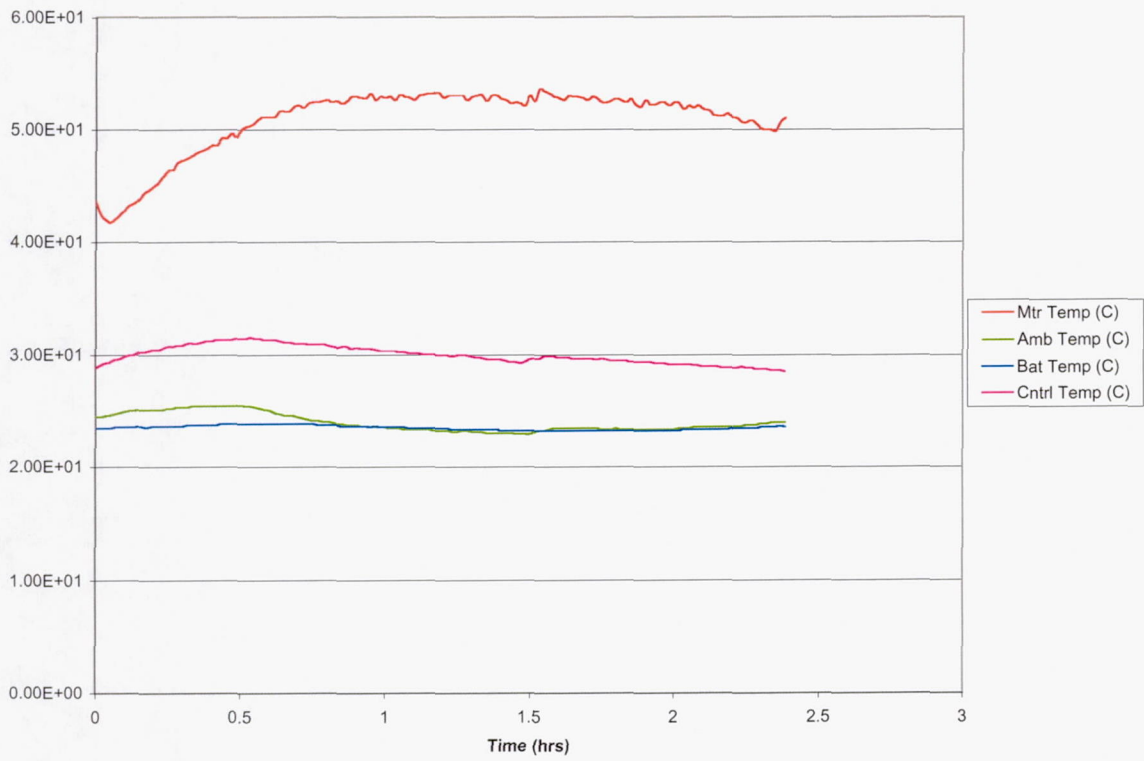
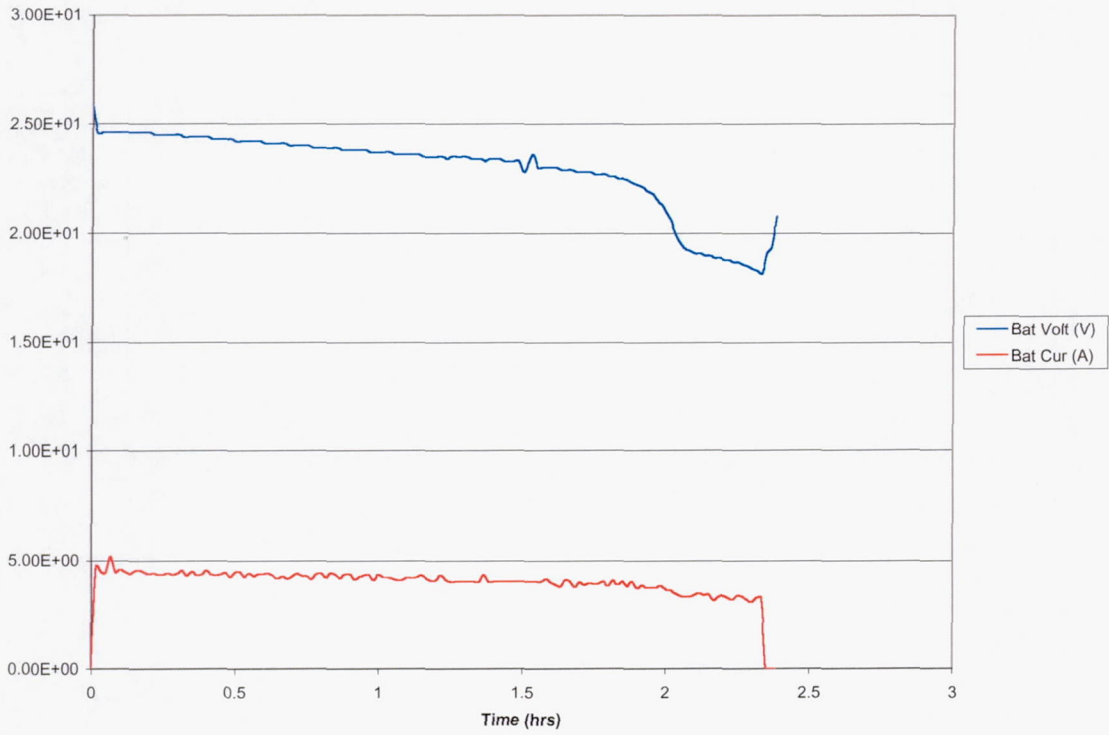

Test 4: Range Test, +2% Grade, Maximum Initial Speed, Normal Mode

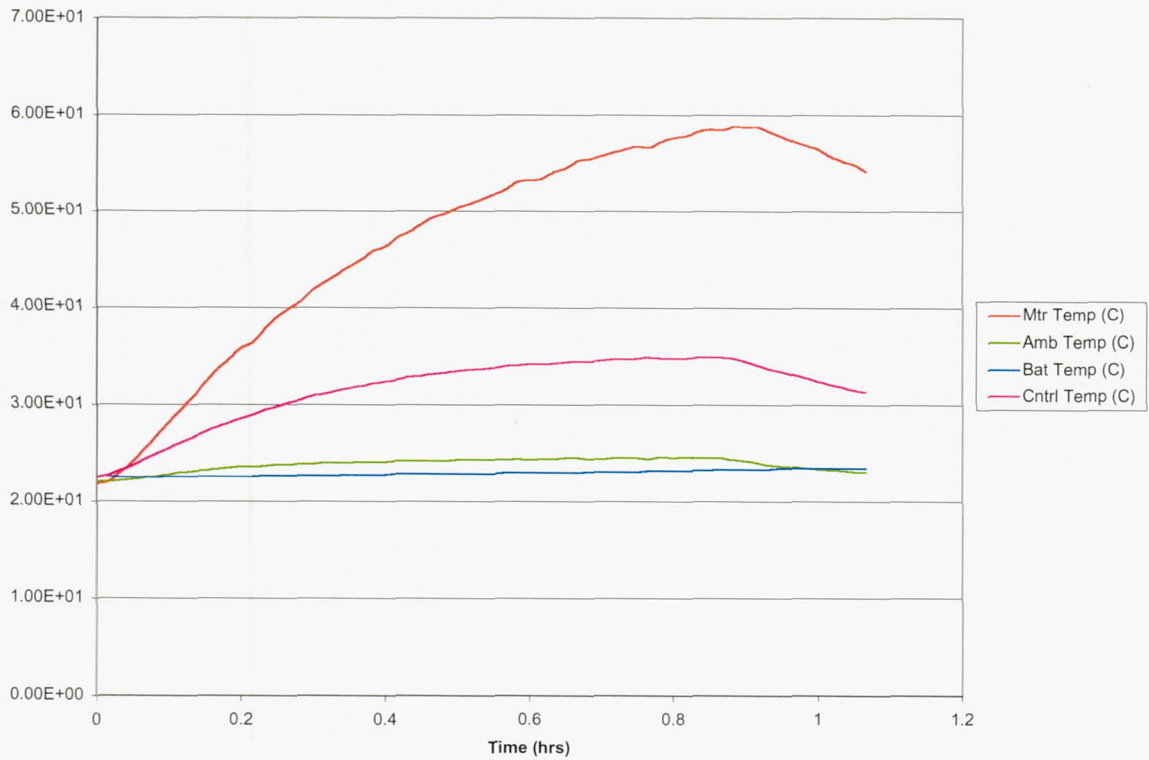
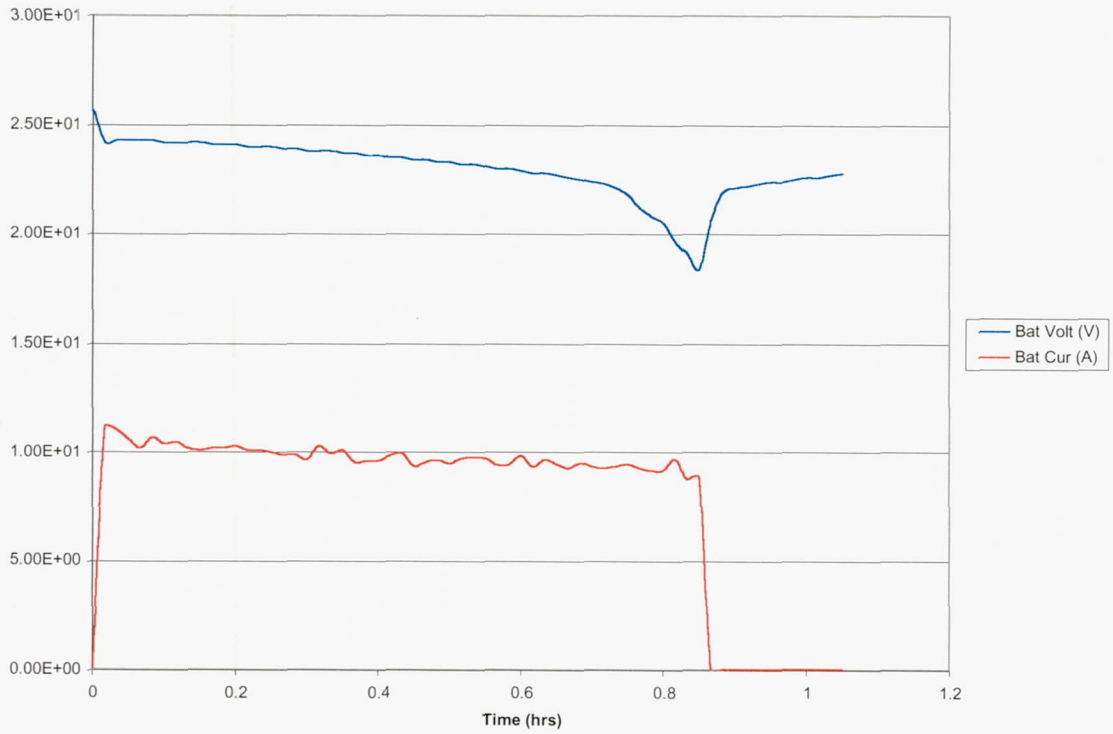

**Test 5: Range Test, +4% Grade, Maximum Initial speed, Normal Mode**

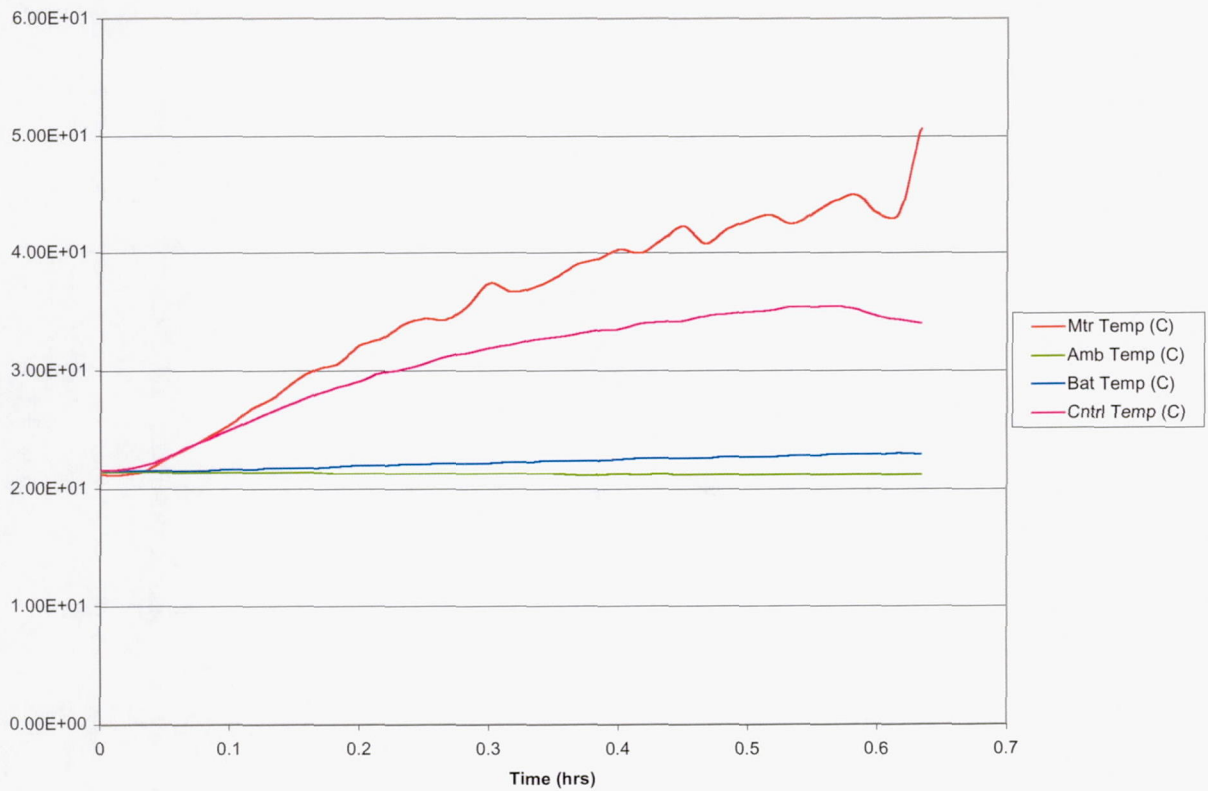
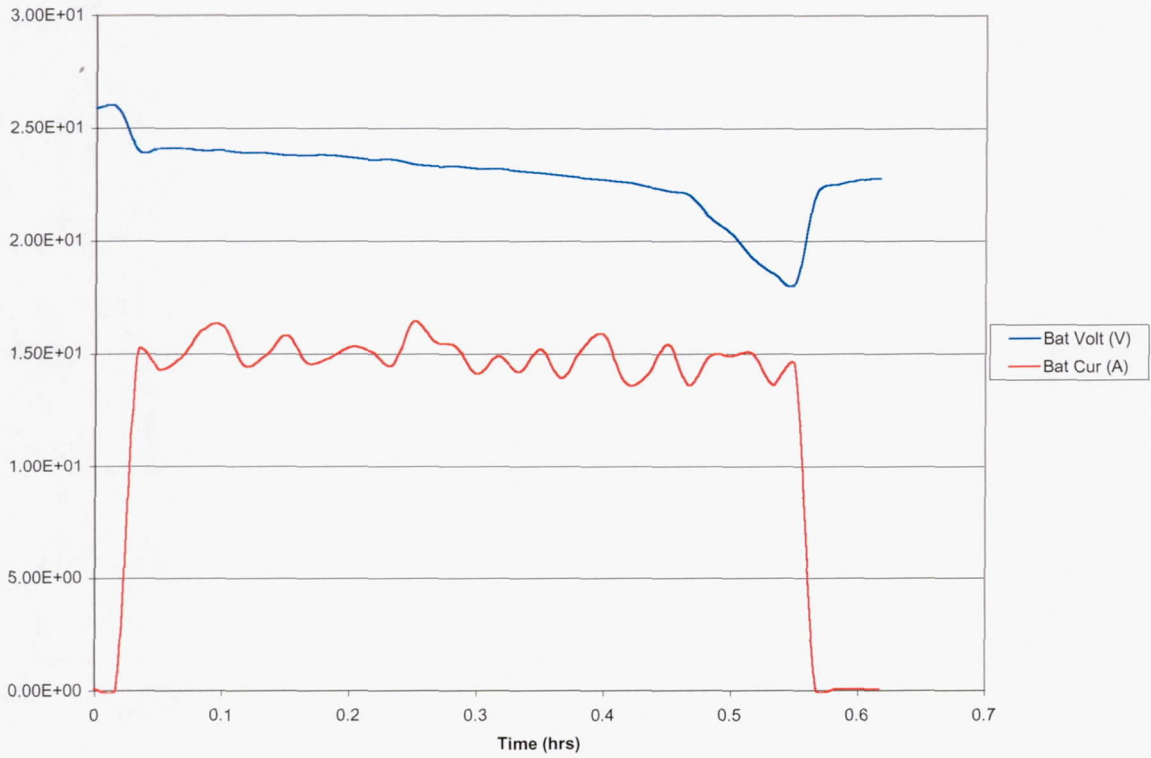

**Test 6: Range Test, +6% Grade, Maximum Initial Speed, Normal Mode**

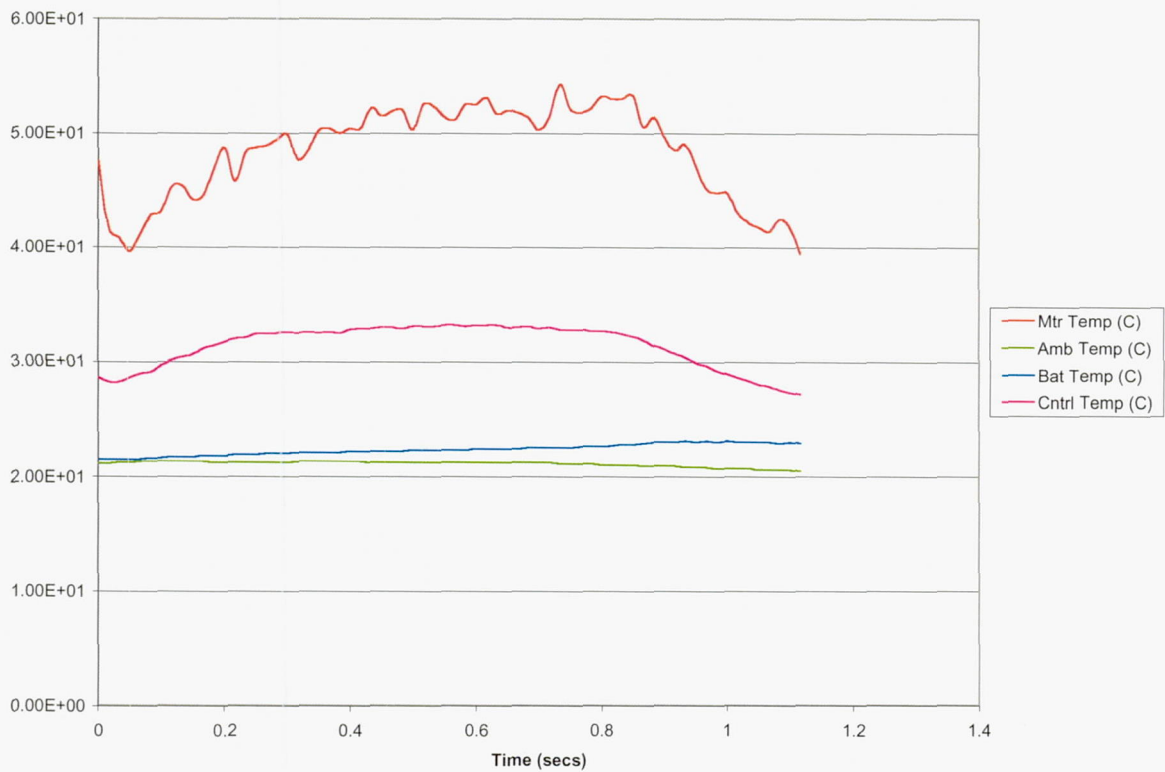
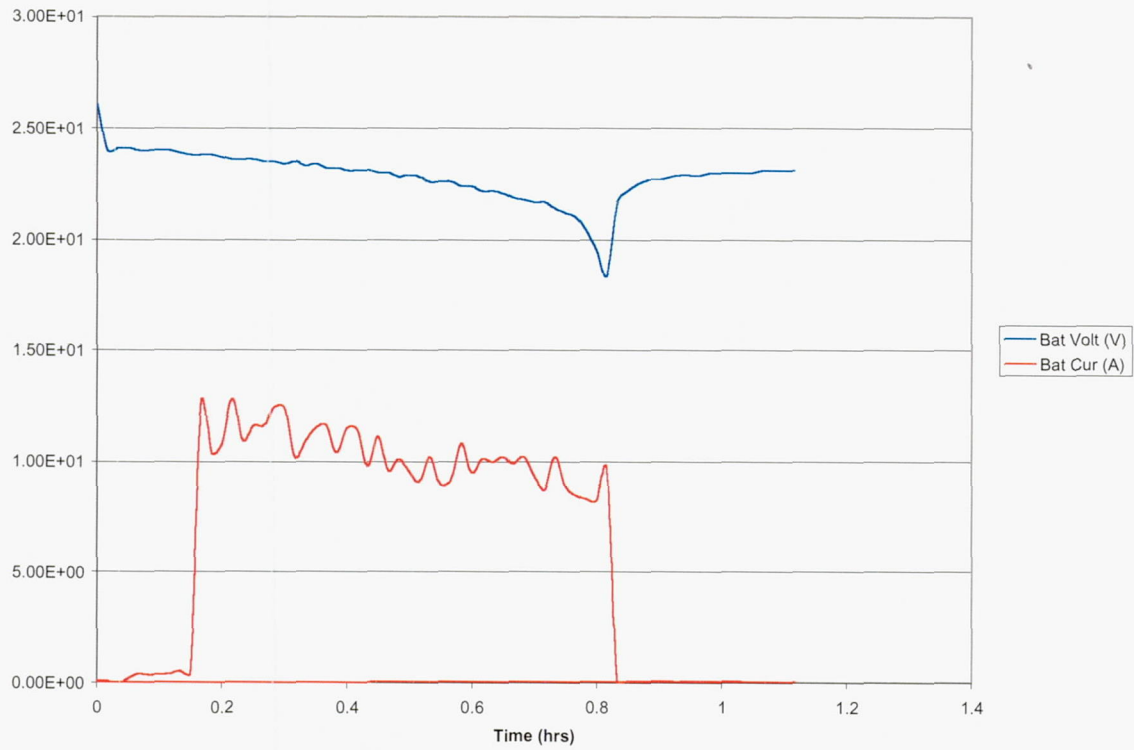

### Test 7: Range Test, +8% Grade, Maximum Initial Speed, Normal Mode

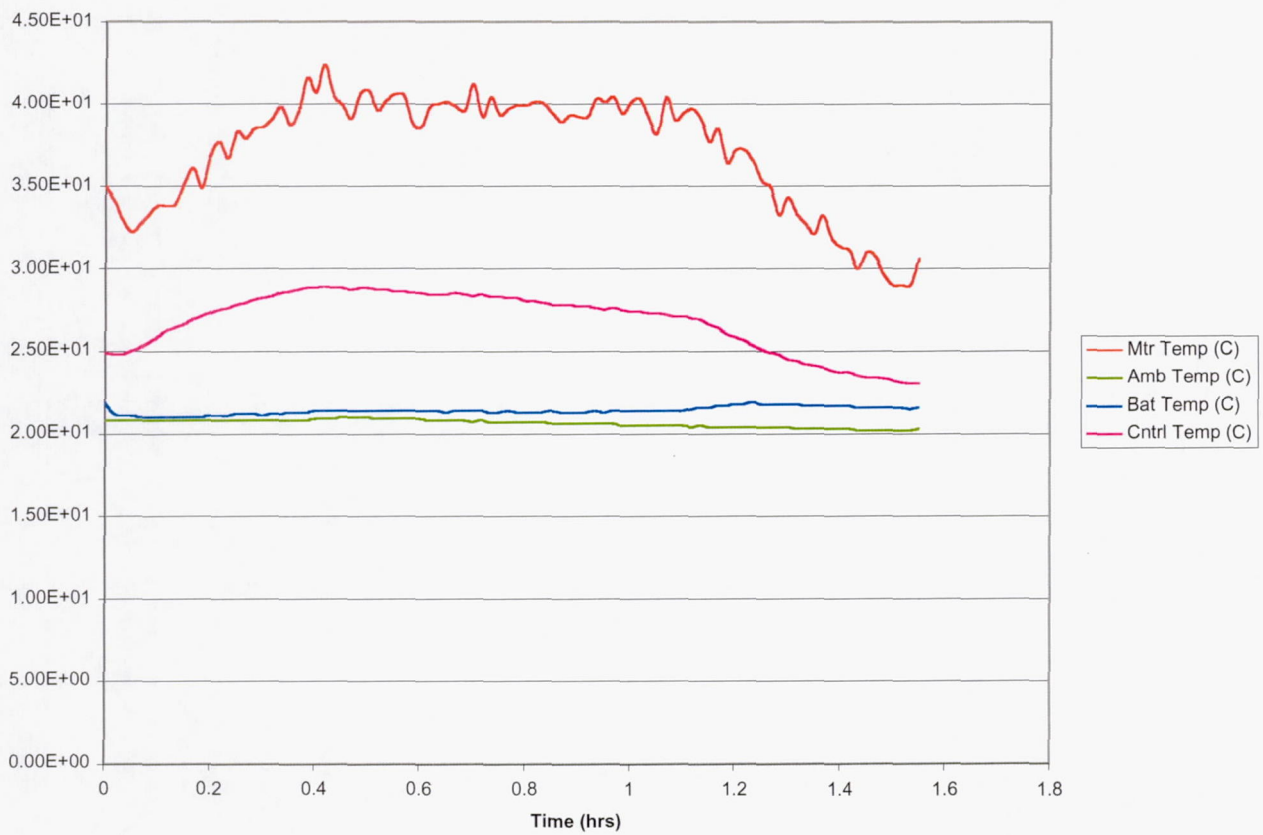
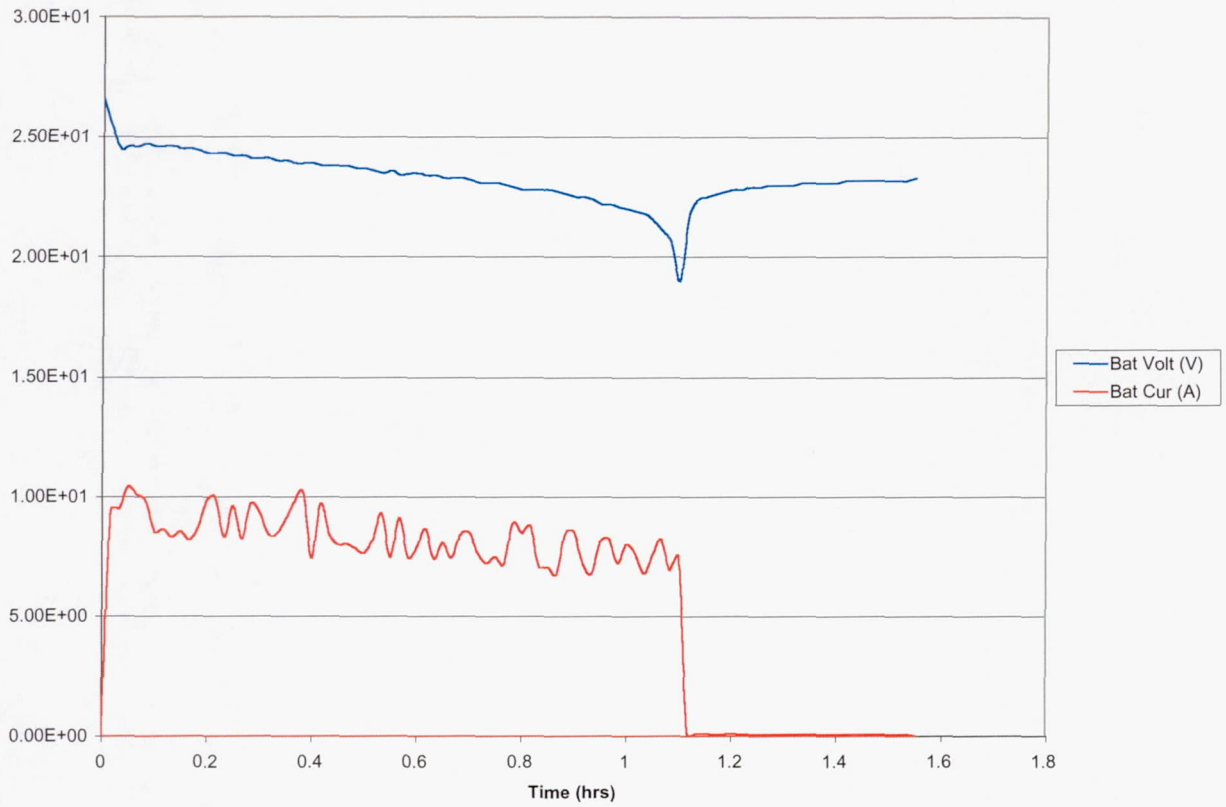

### Test 8: Acceleration Test, 0% Grade, Maximum Initial Speed, Normal Mode

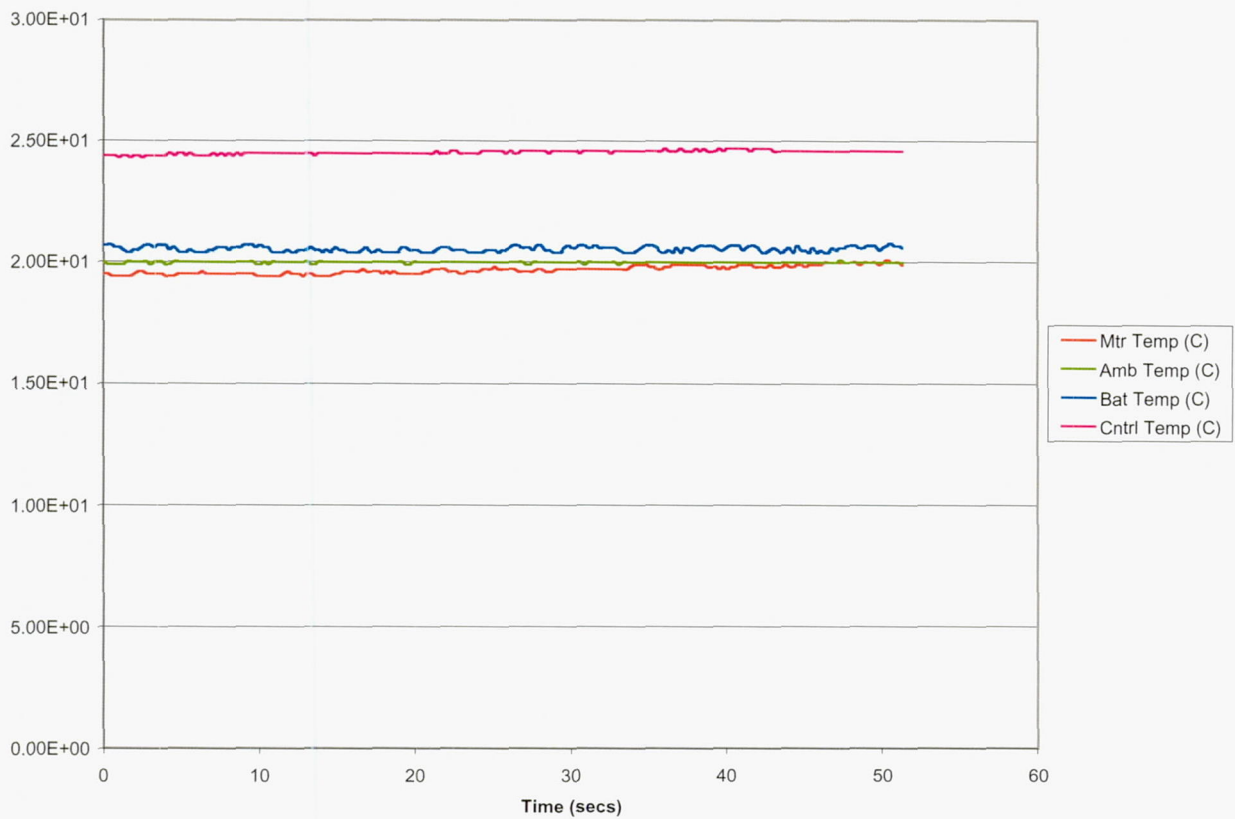
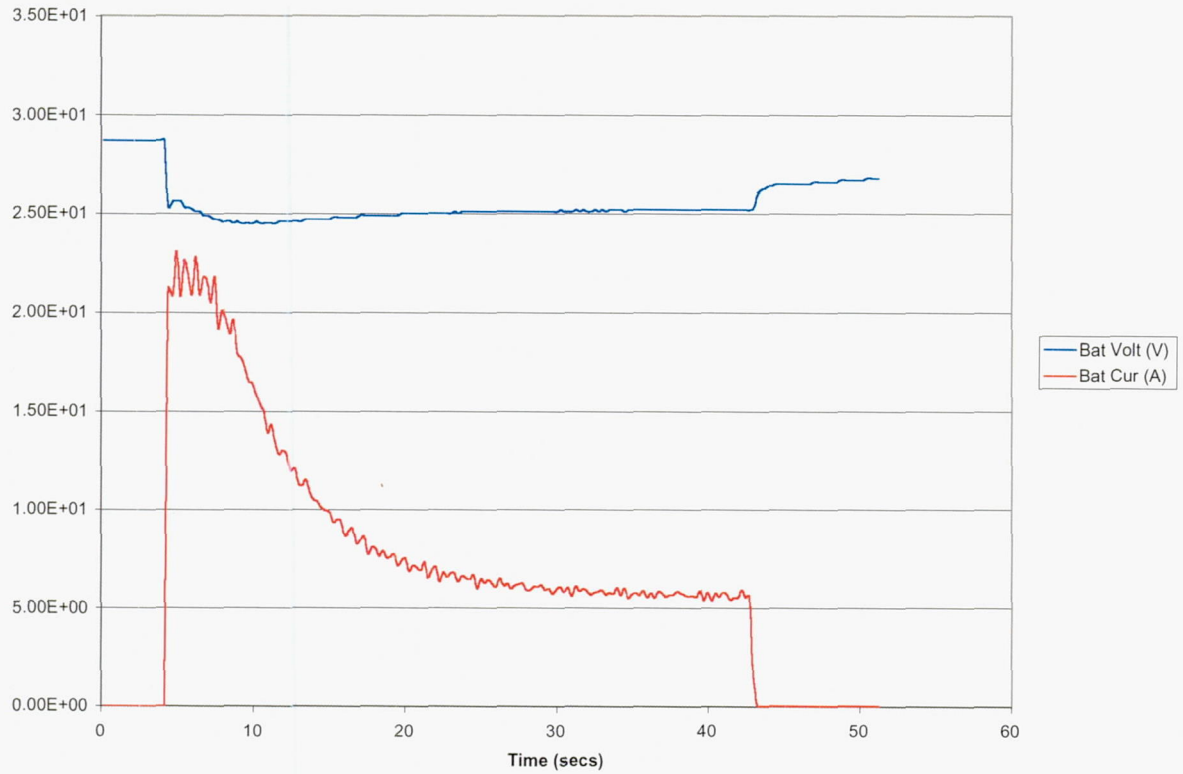

**Test 9: Acceleration Test, 0% Grade, Maximum Initial Speed, Economy Mode**

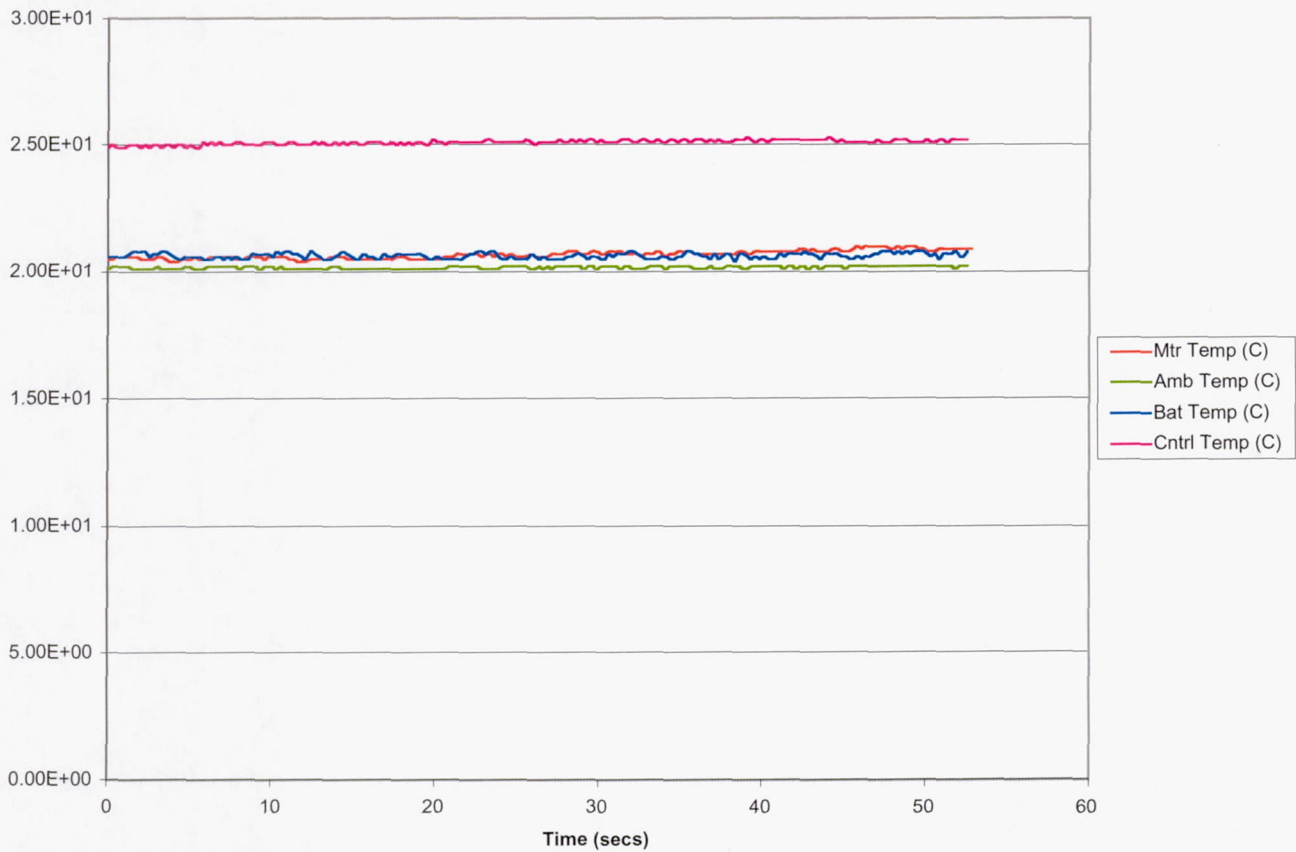
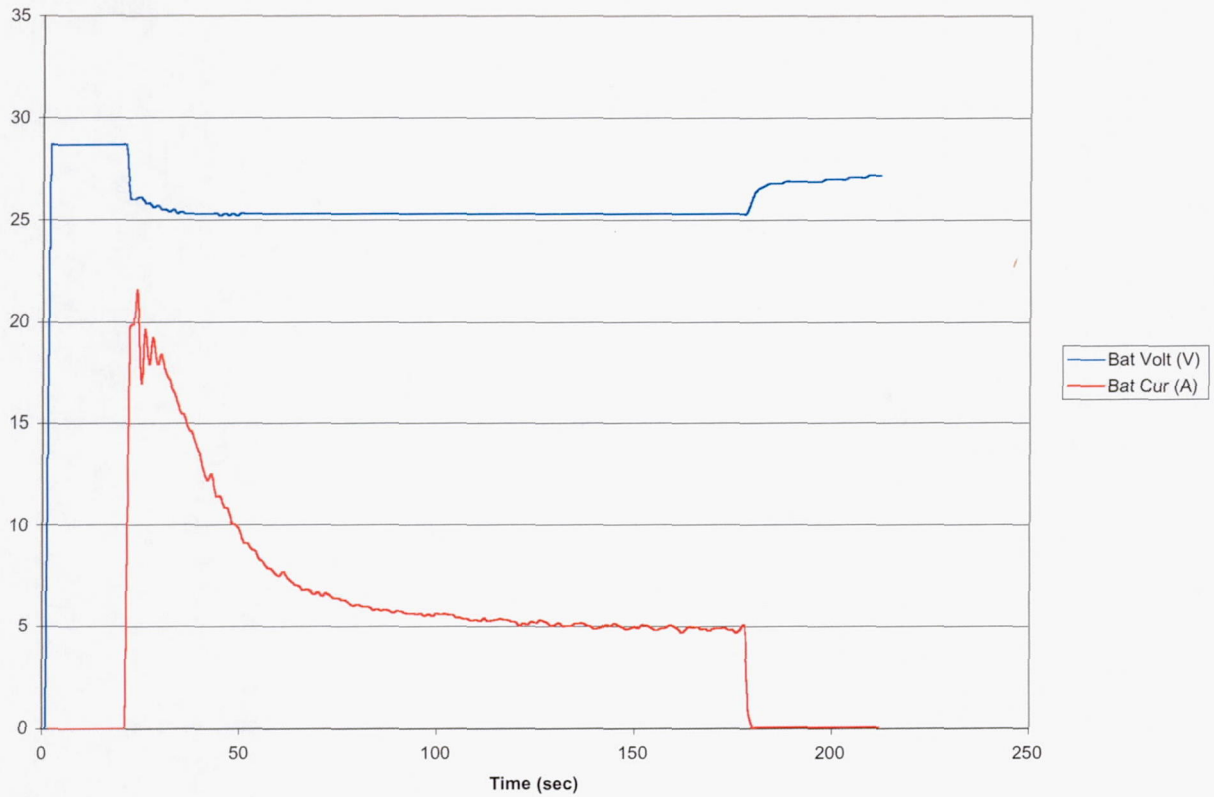

### Test 10: Acceleration Test, +2% Grade, Maximum Initial speed, Normal Mode

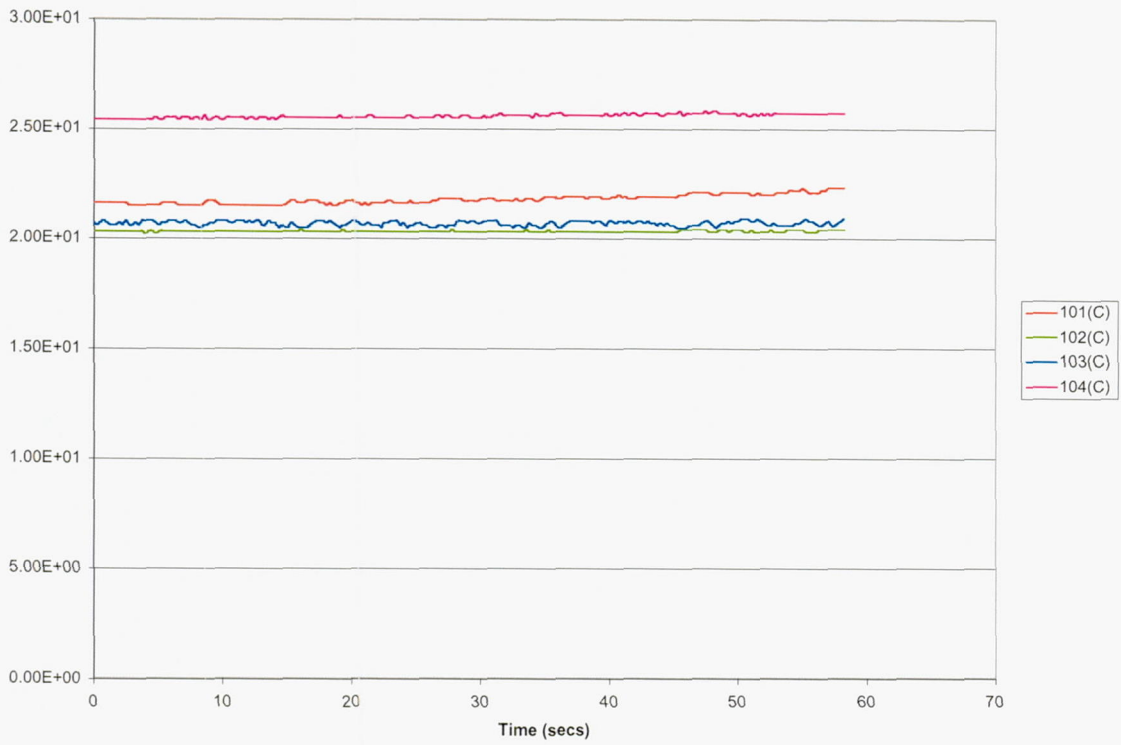
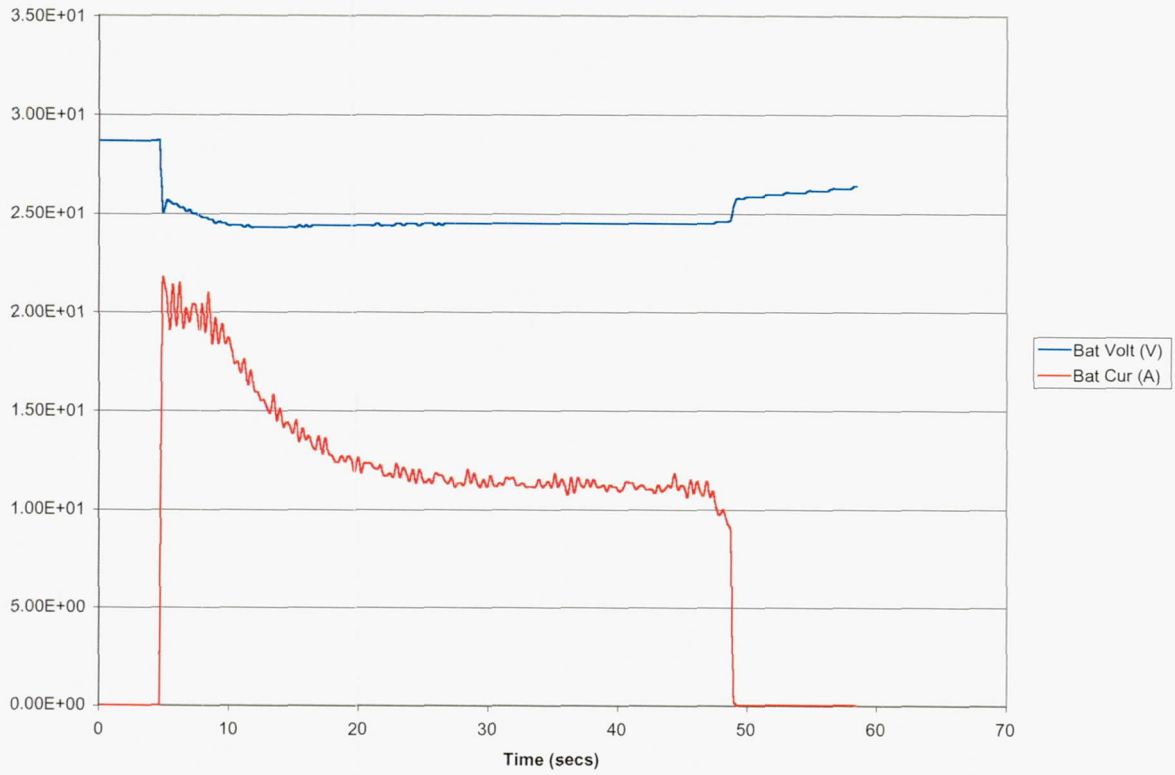

### Test 11: Acceleration Test, +2% Grade, Maximum Initial Speed, Economy Mode

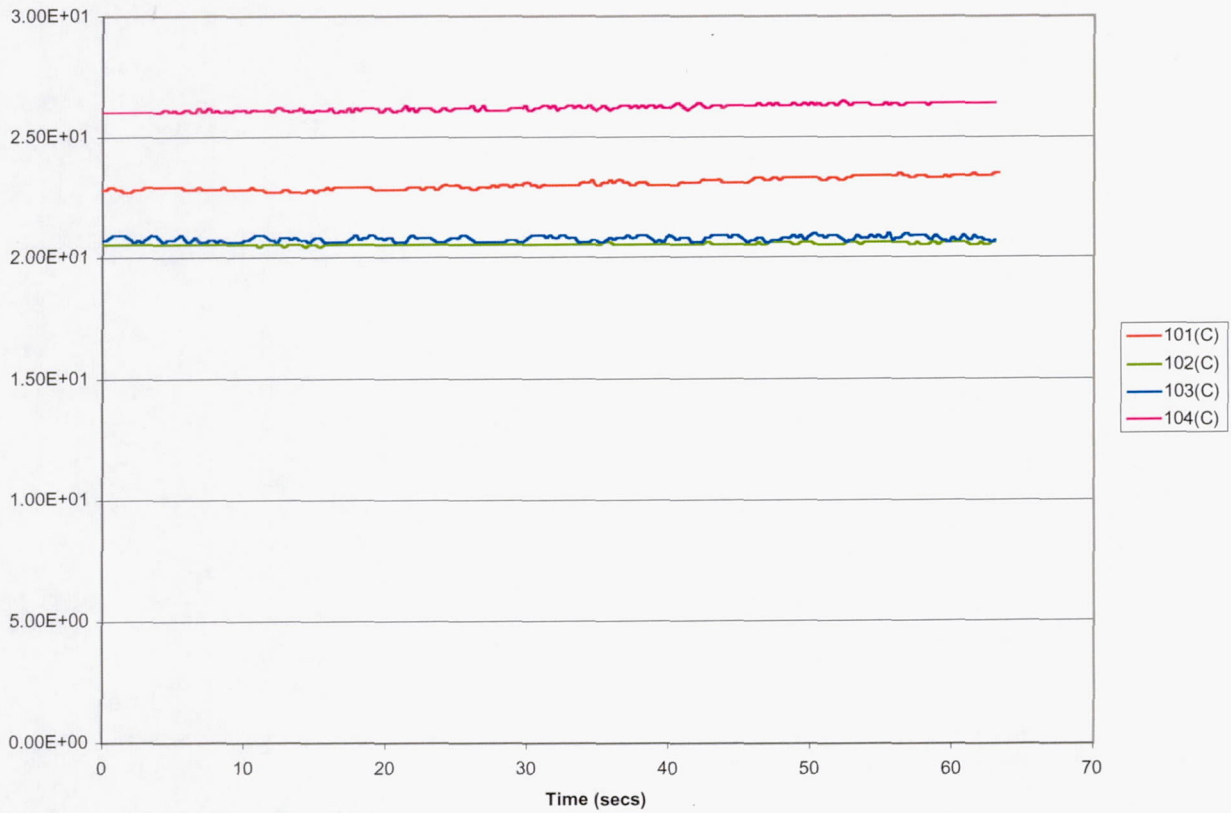
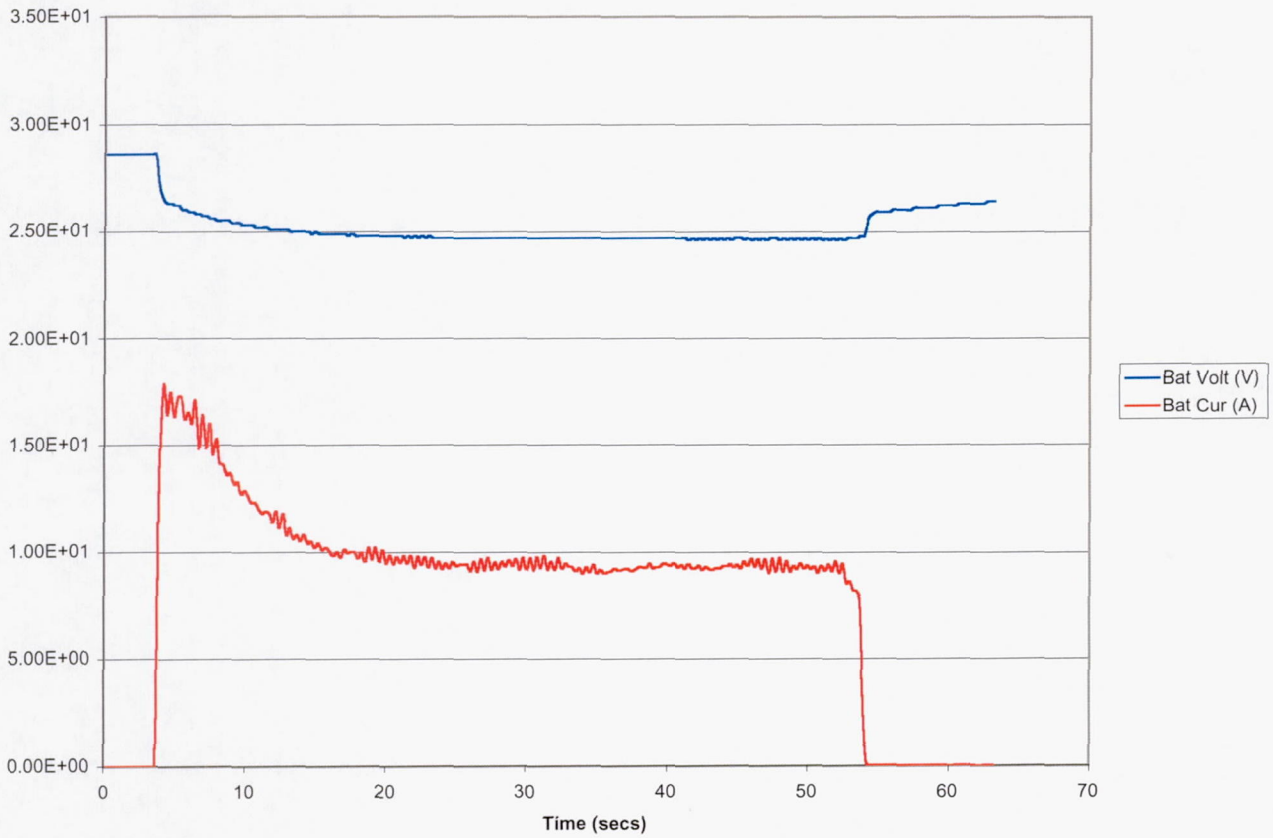

### Test 12: Acceleration Test, +4% Grade, Maximum Initial Speed, Normal Mode

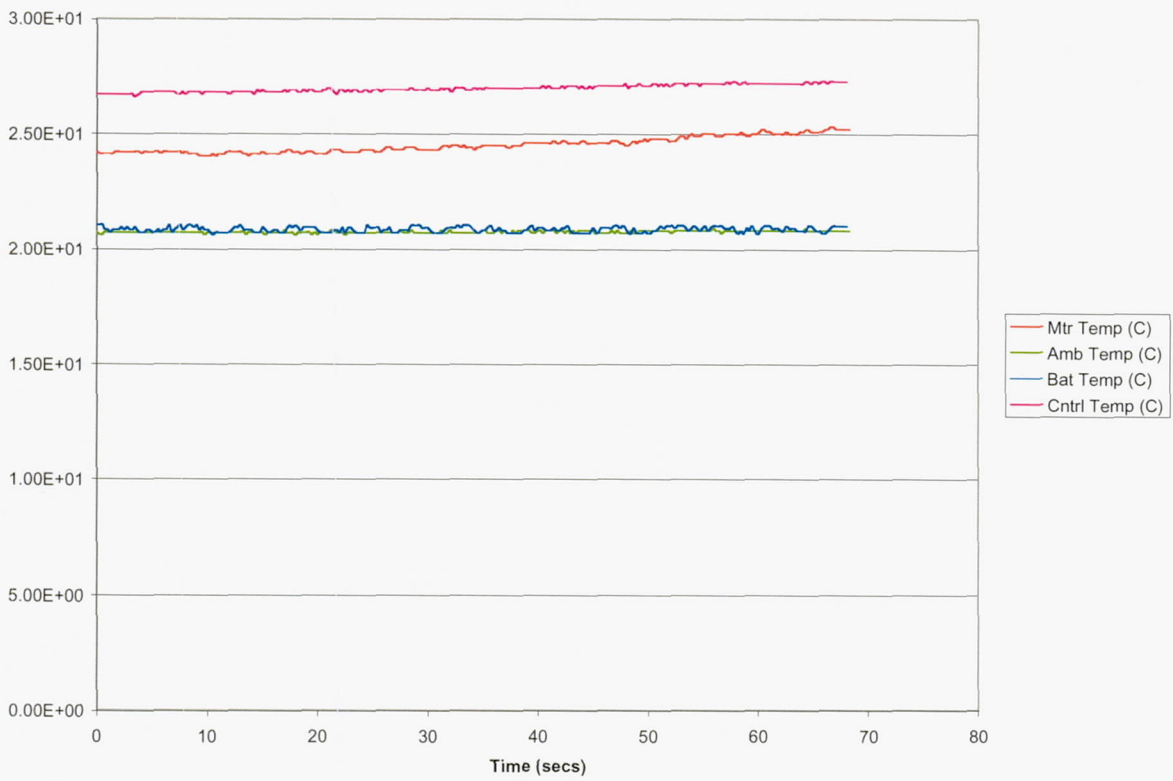
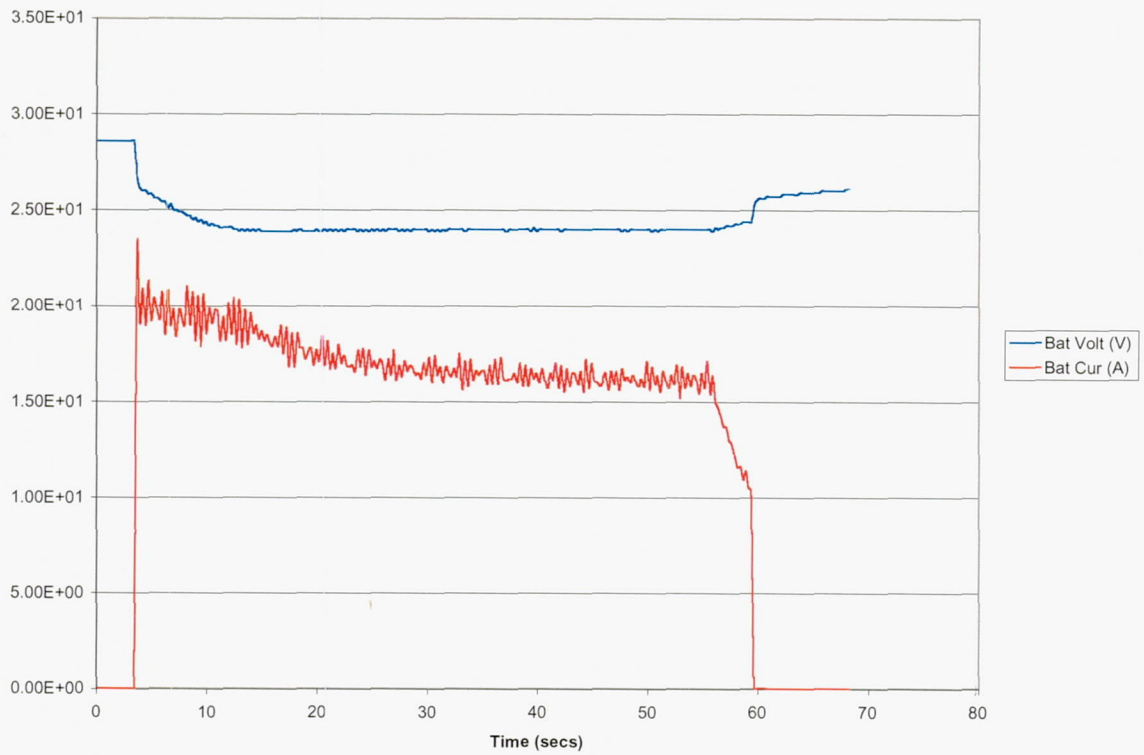

### Test 13: Acceleration Test, +4% Grade, Maximum Initial Speed, Economy Mode

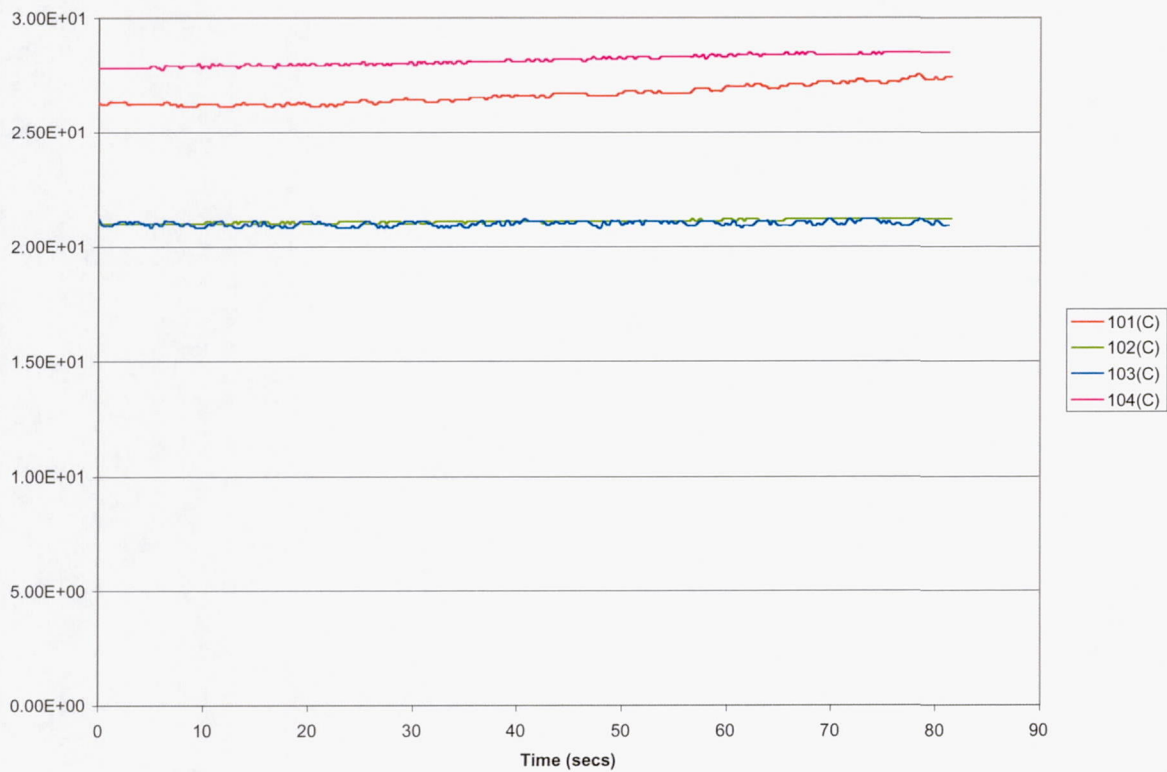
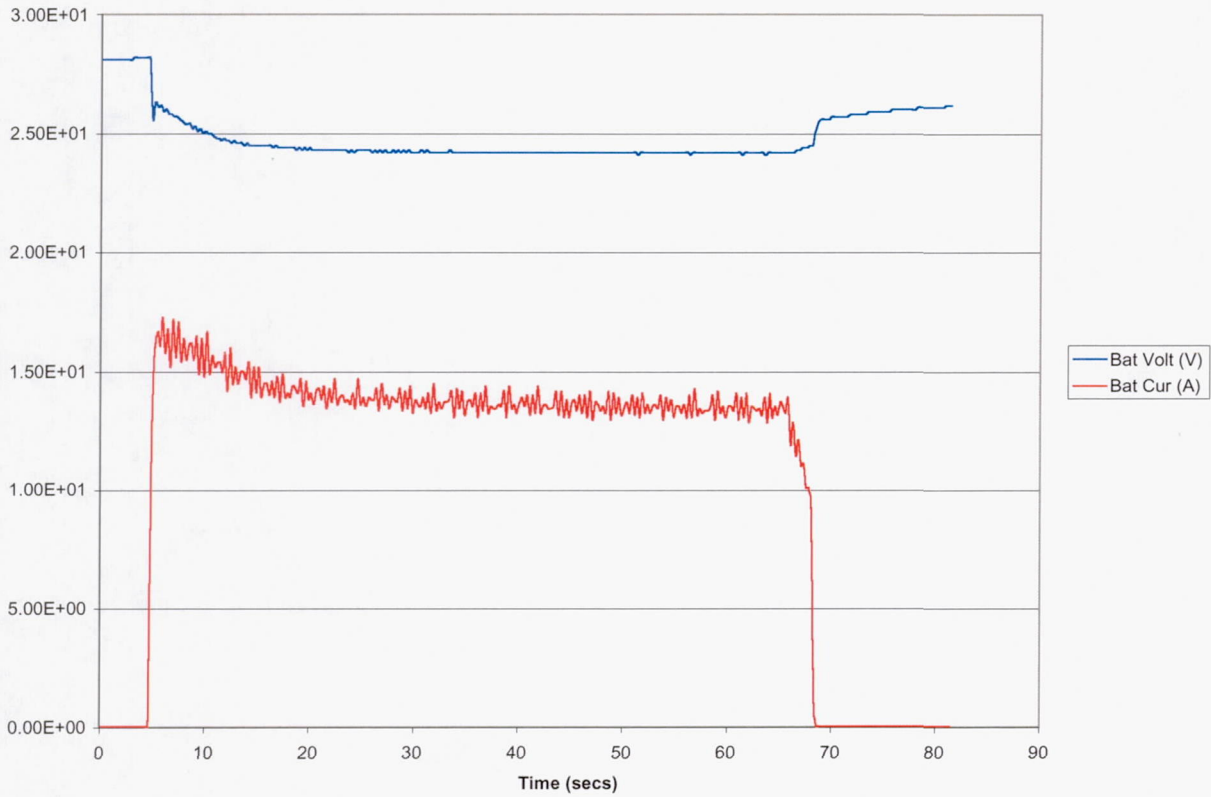

### Test 14: Acceleration Test, +6% Grade, Maximum Initial Speed, Normal Mode

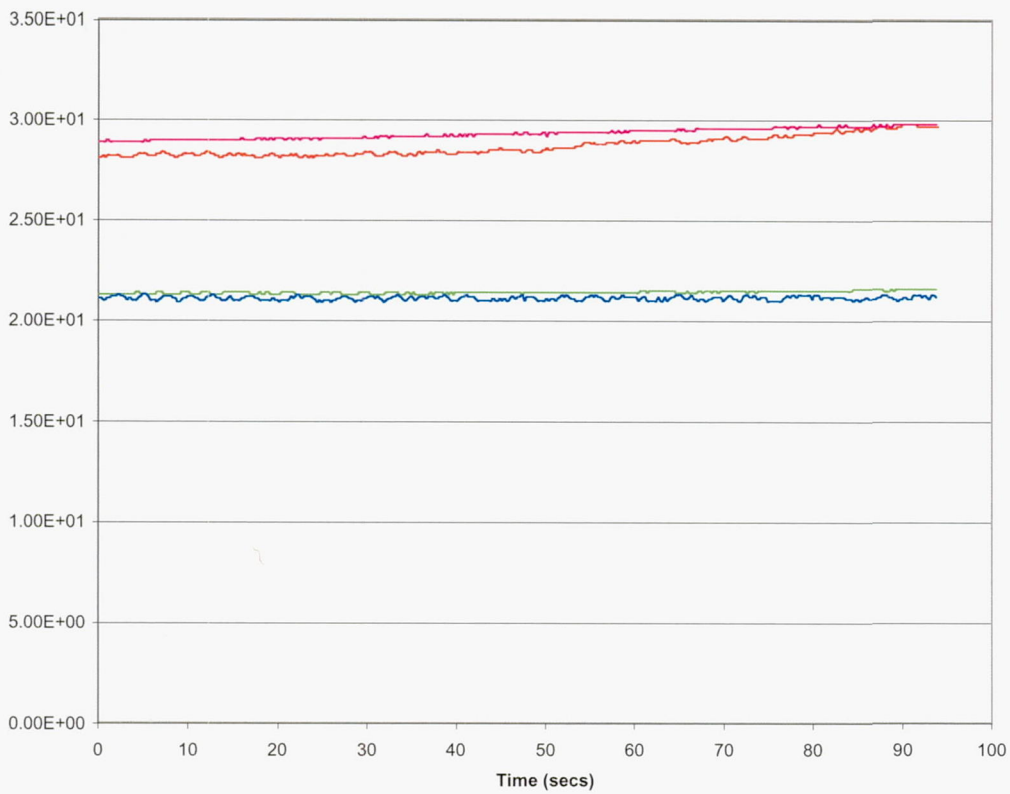
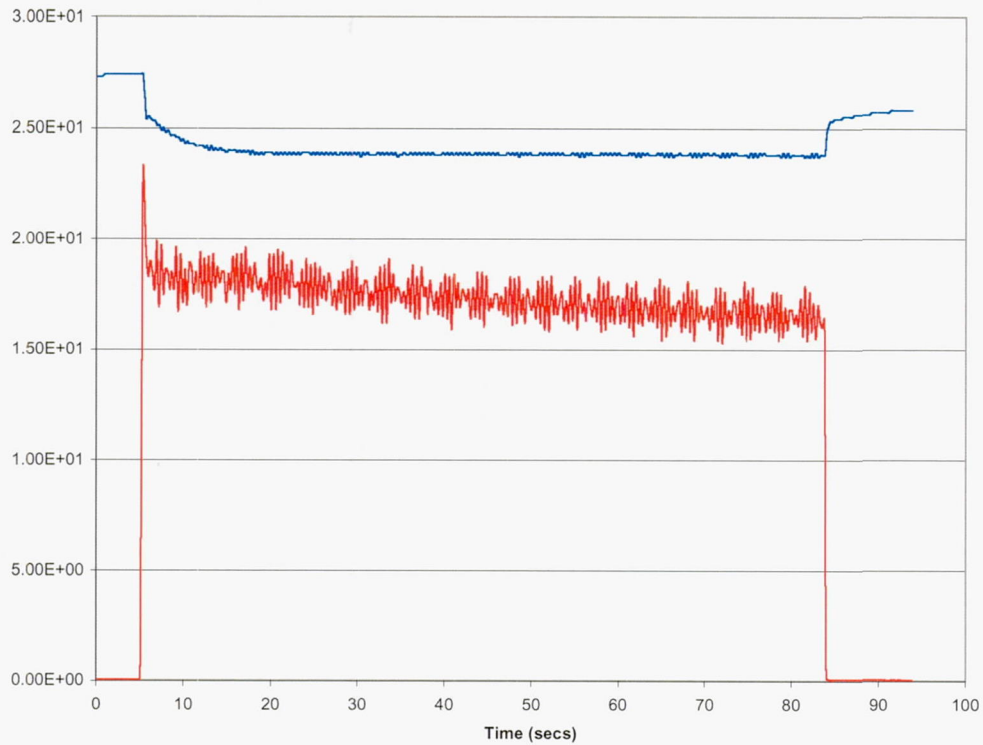

### Test 15: Acceleration Test, +6% Grade, Maximum Initial Speed, Economy Mode

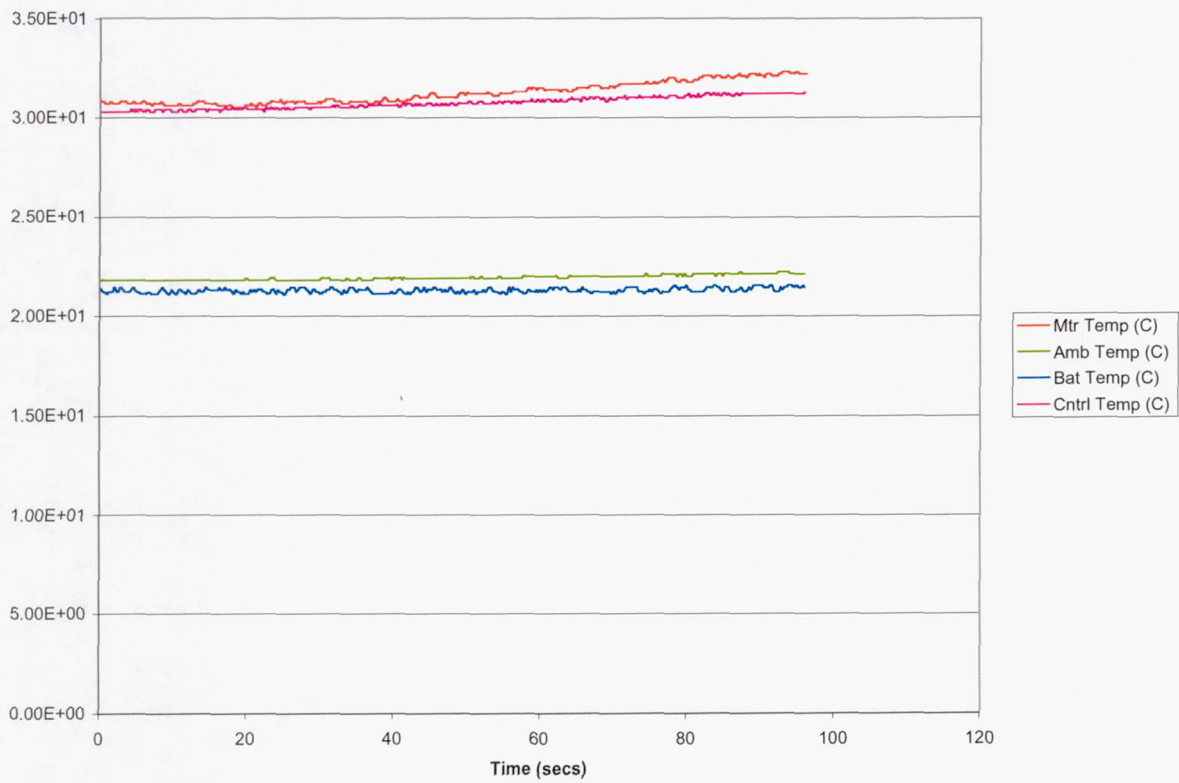
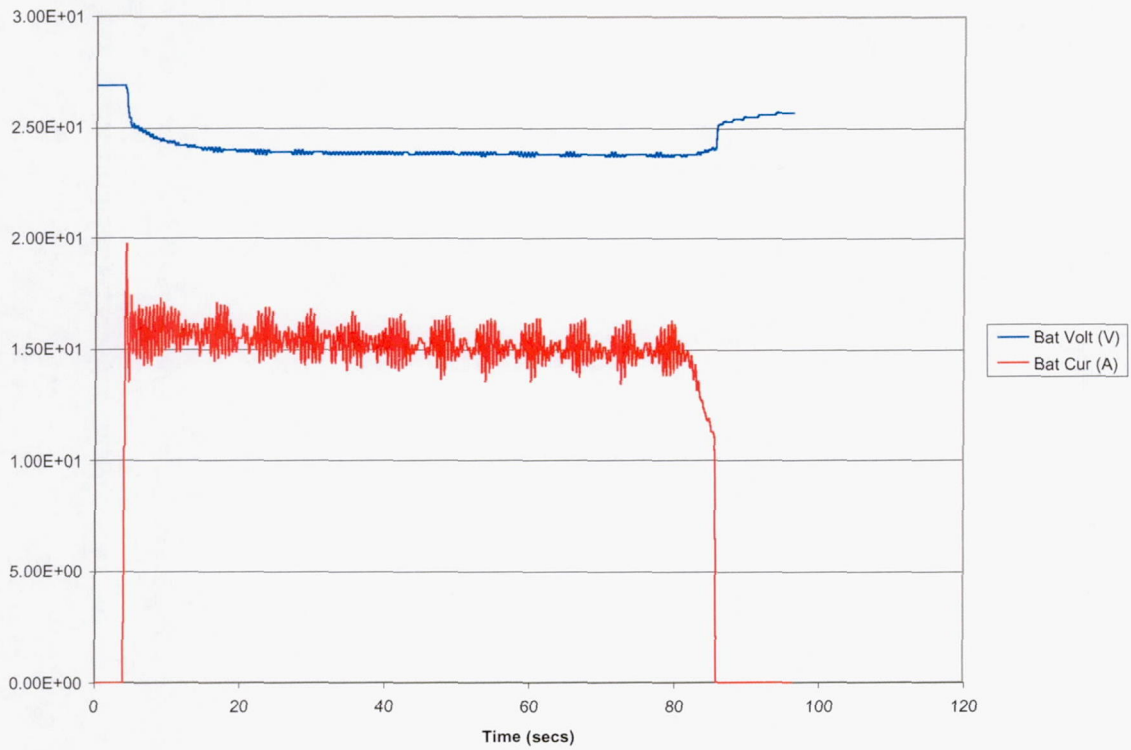

### Test 16: Acceleration Test, +8% Grade, Maximum Initial Speed, Normal Mode

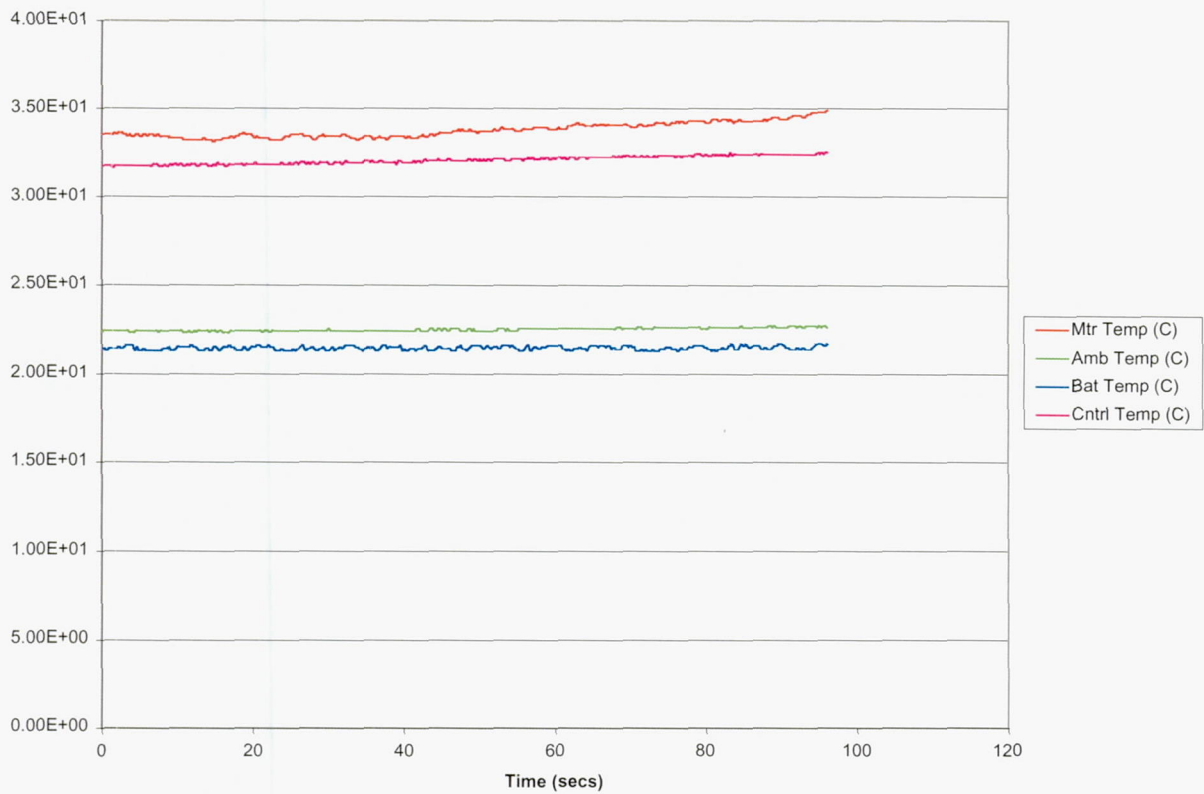
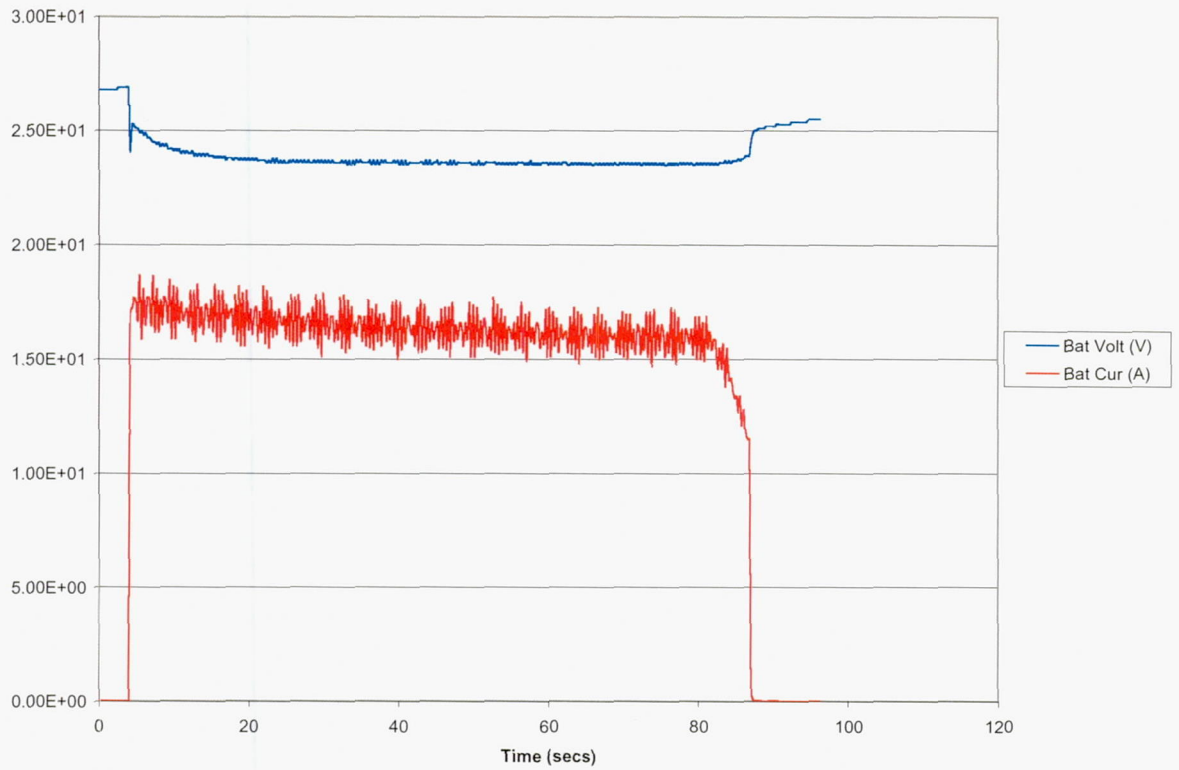

### Test 17: Acceleration Test, +8% Grade, Maximum Initial Speed, Economy Mode

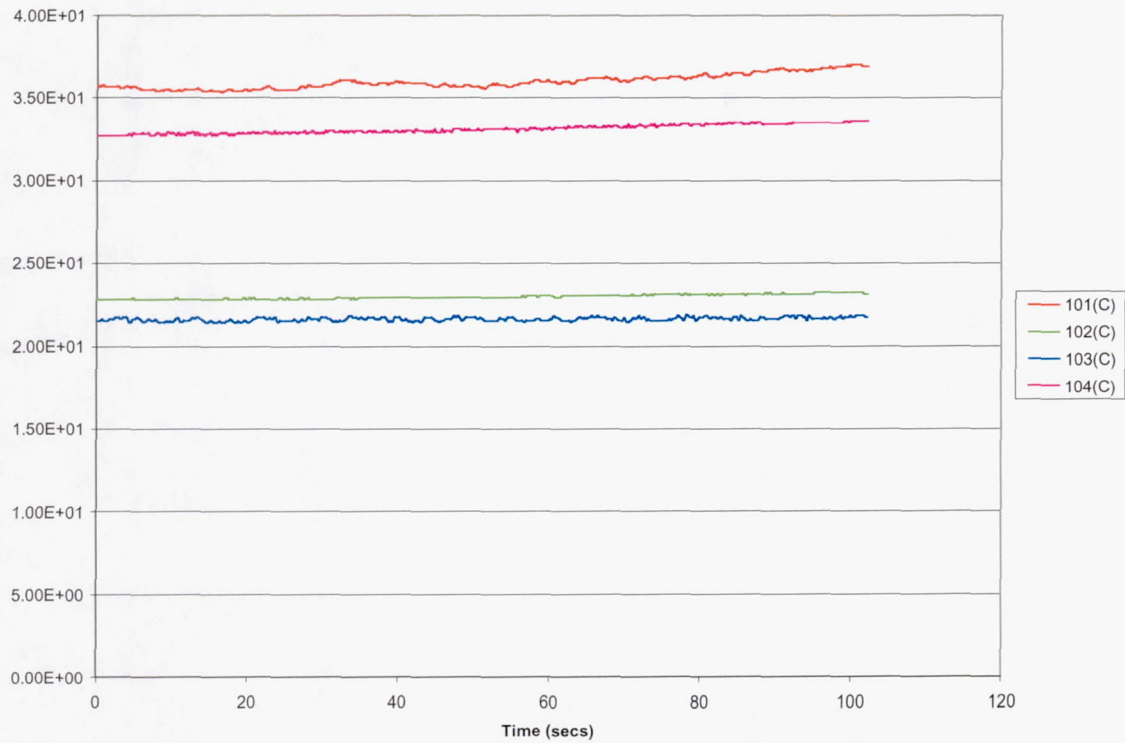
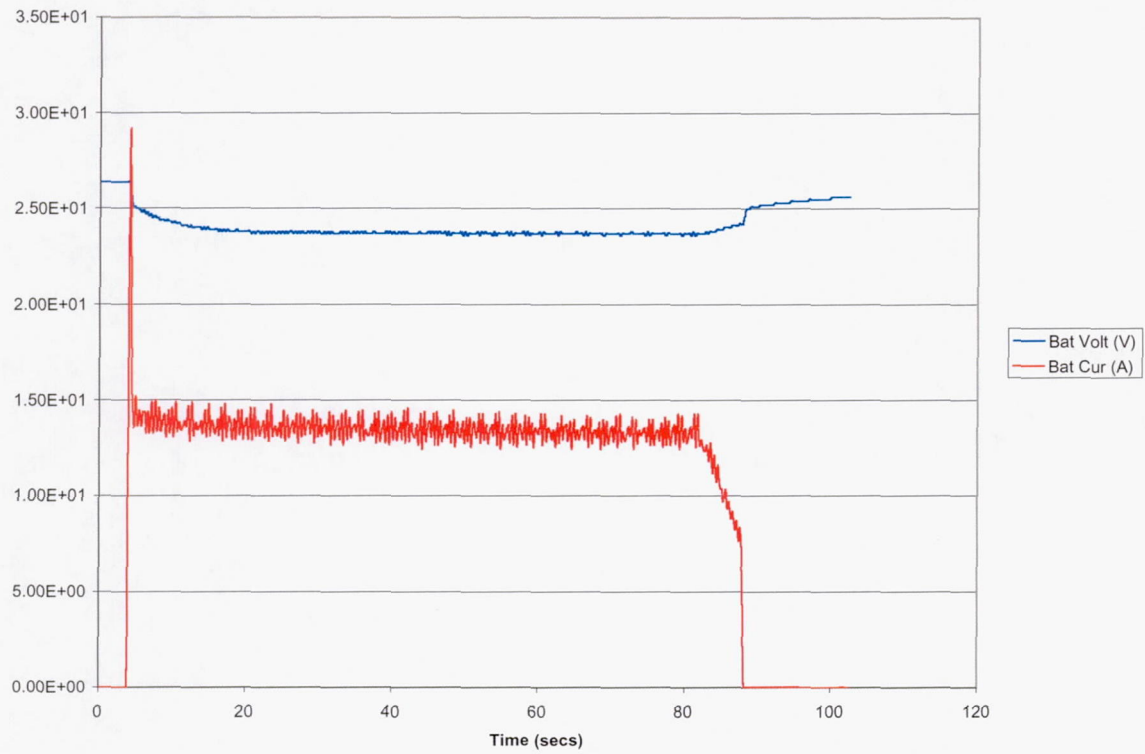

### Test 18: Stop Test, 0% Grade, Maximum Initial Speed, Normal Mode

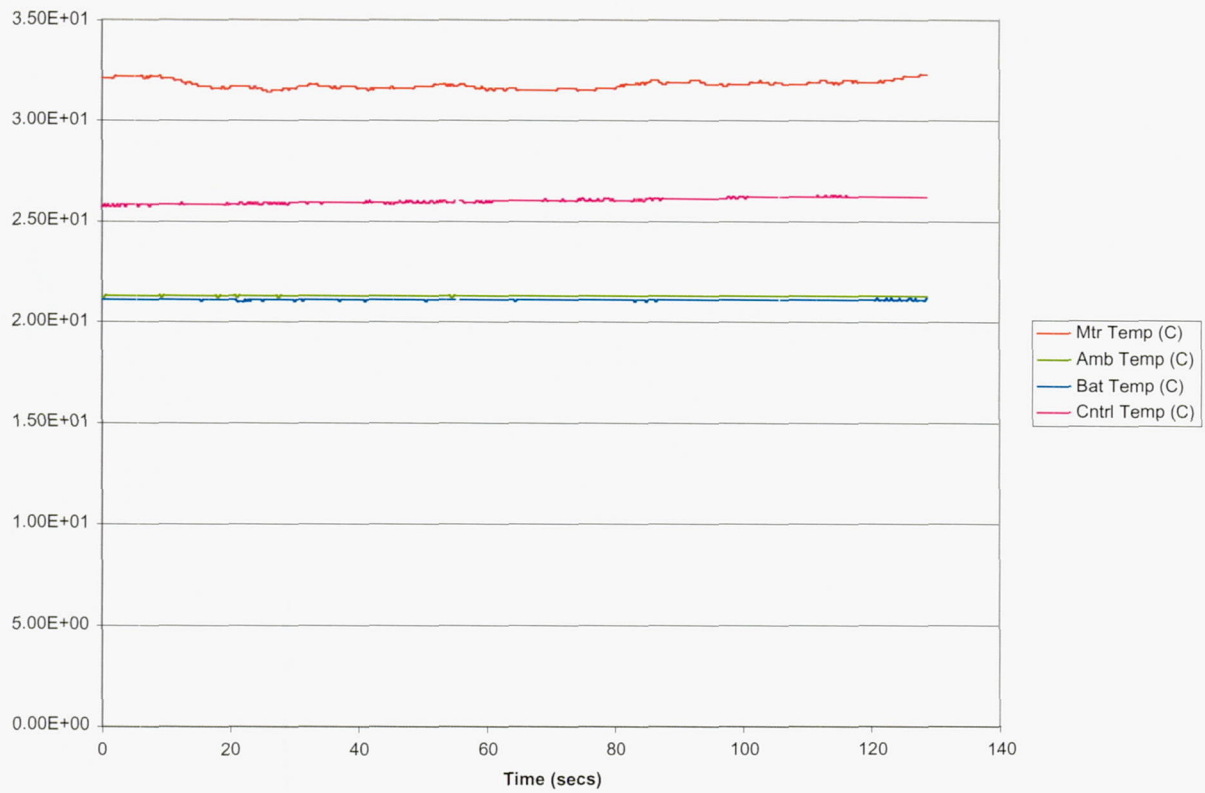
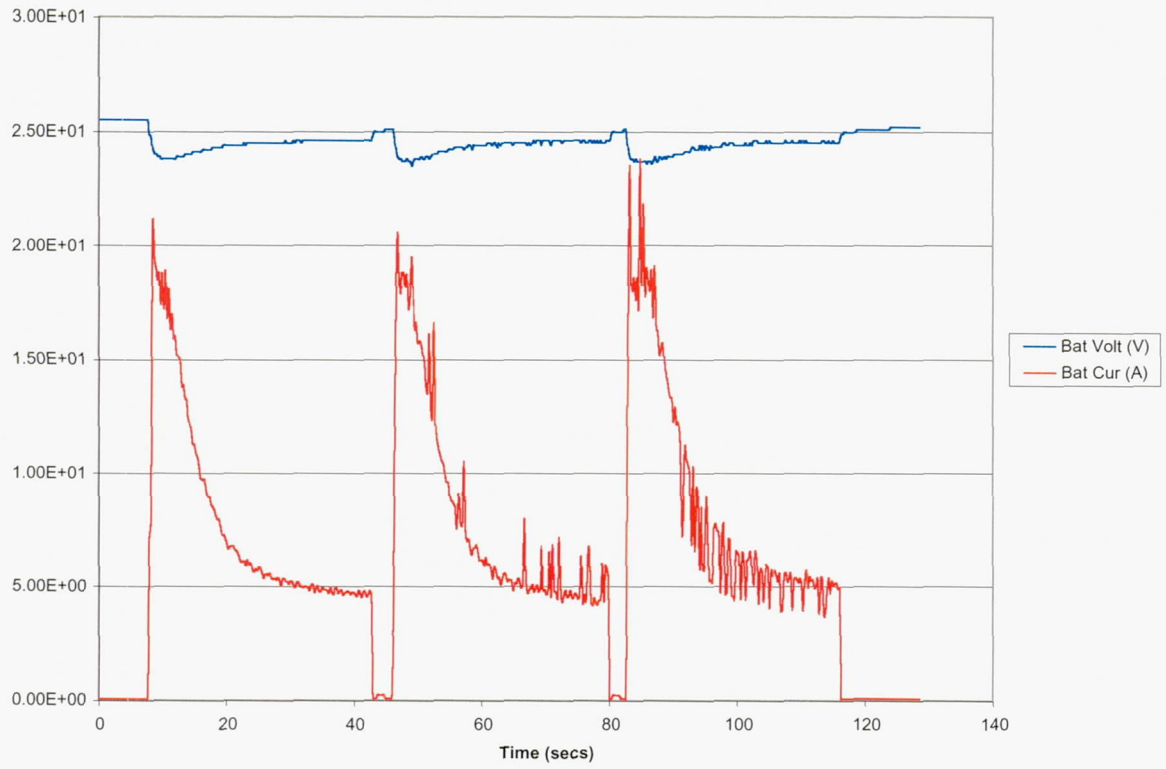

### Test 19: Stop Test, 0% Grade, Maximum Initial Speed, Economy Mode

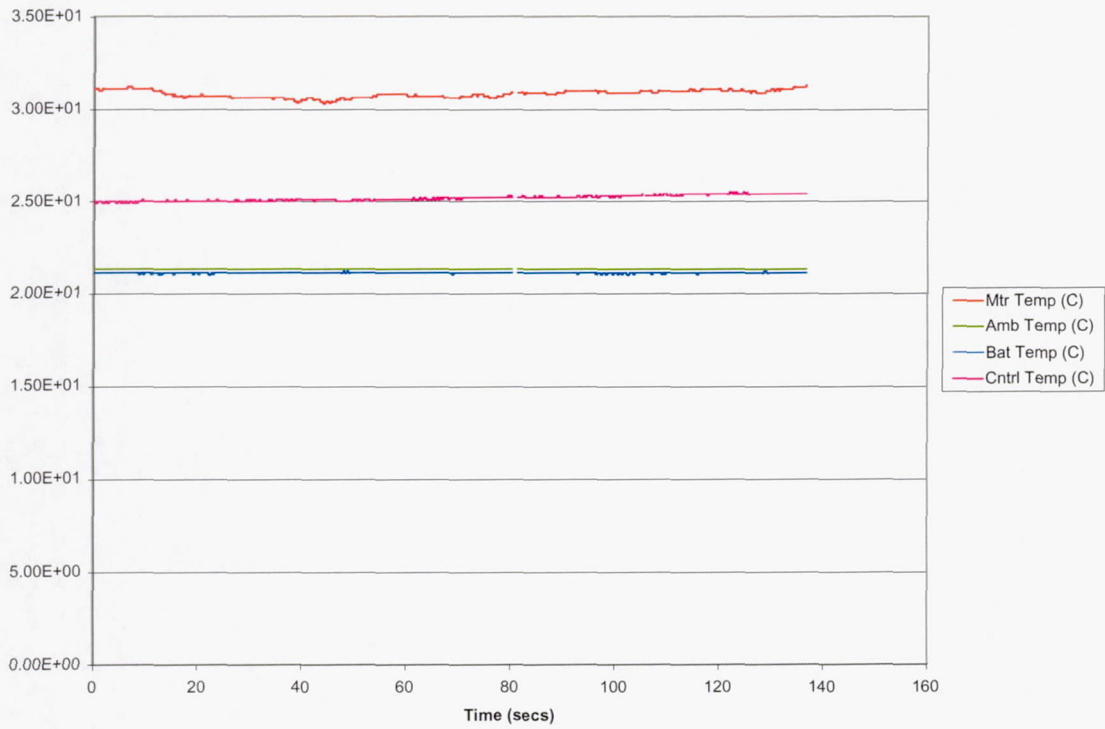
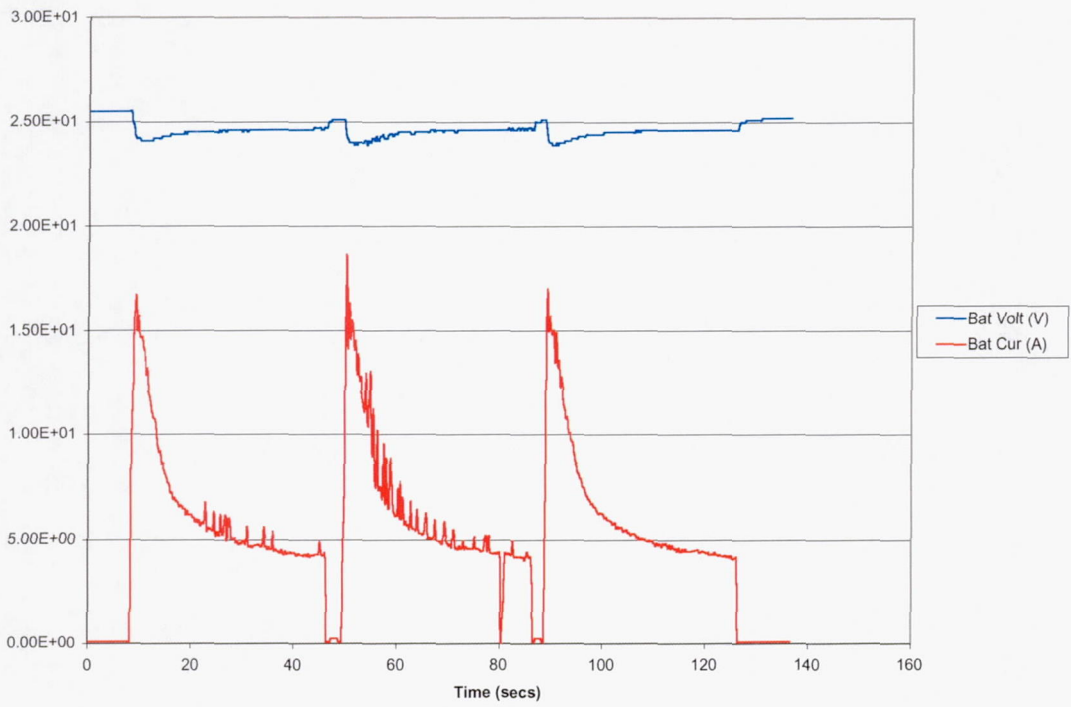

### Test 20: Stop Test, +2% Grade, Maximum Initial Speed, Normal Mode

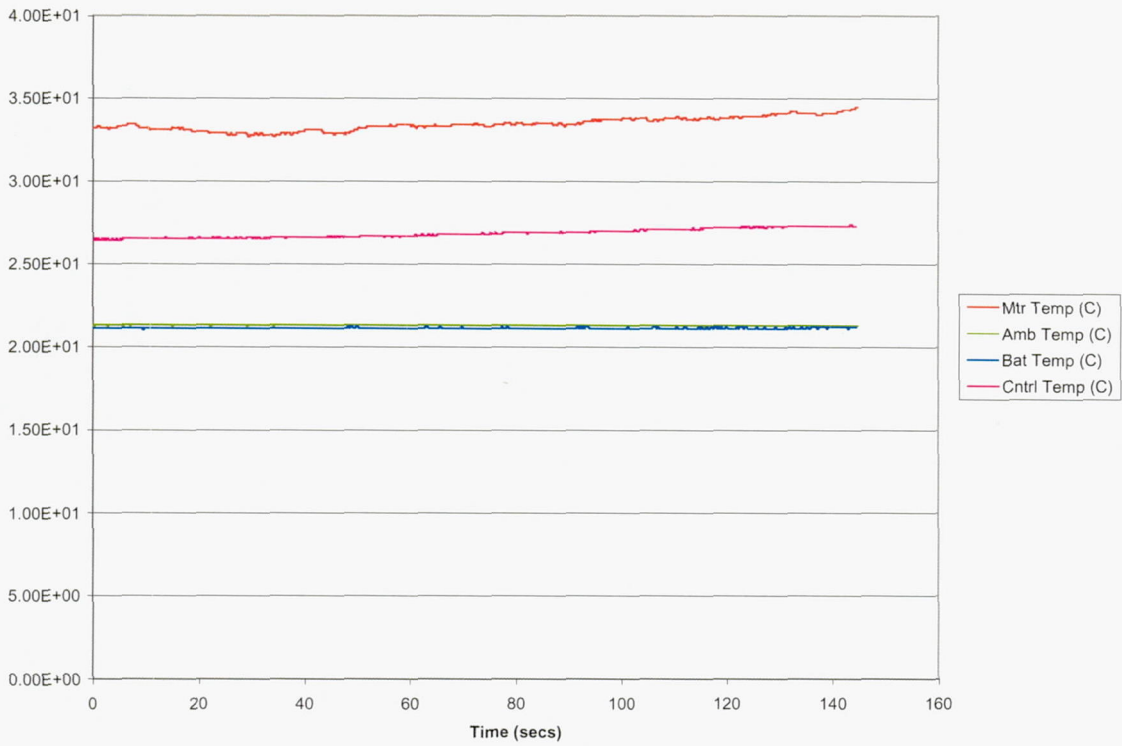
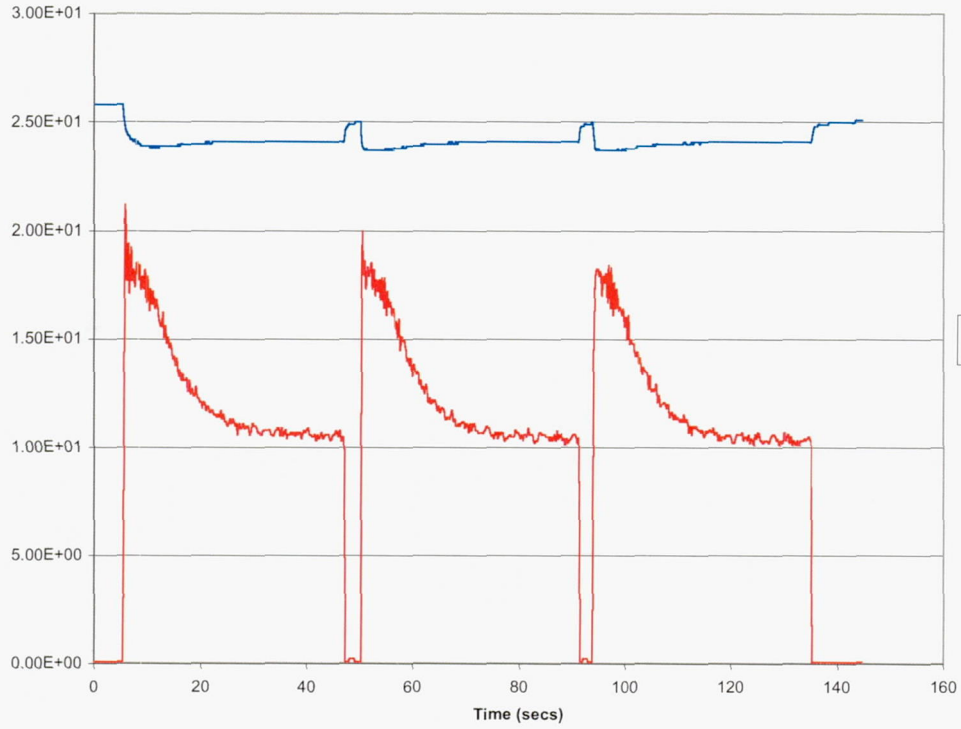

### Test 21: Stop Test, +2% Grade, Maximum Initial Speed, Economy Mode

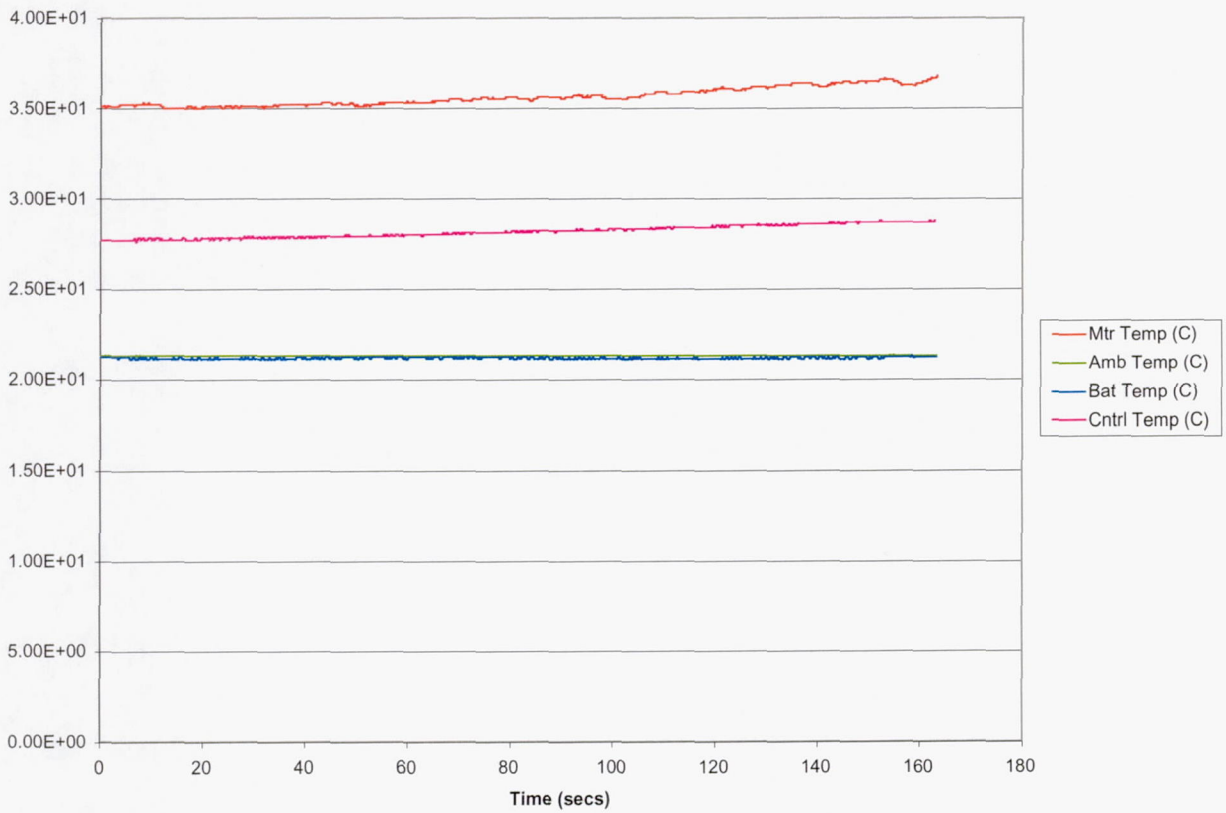
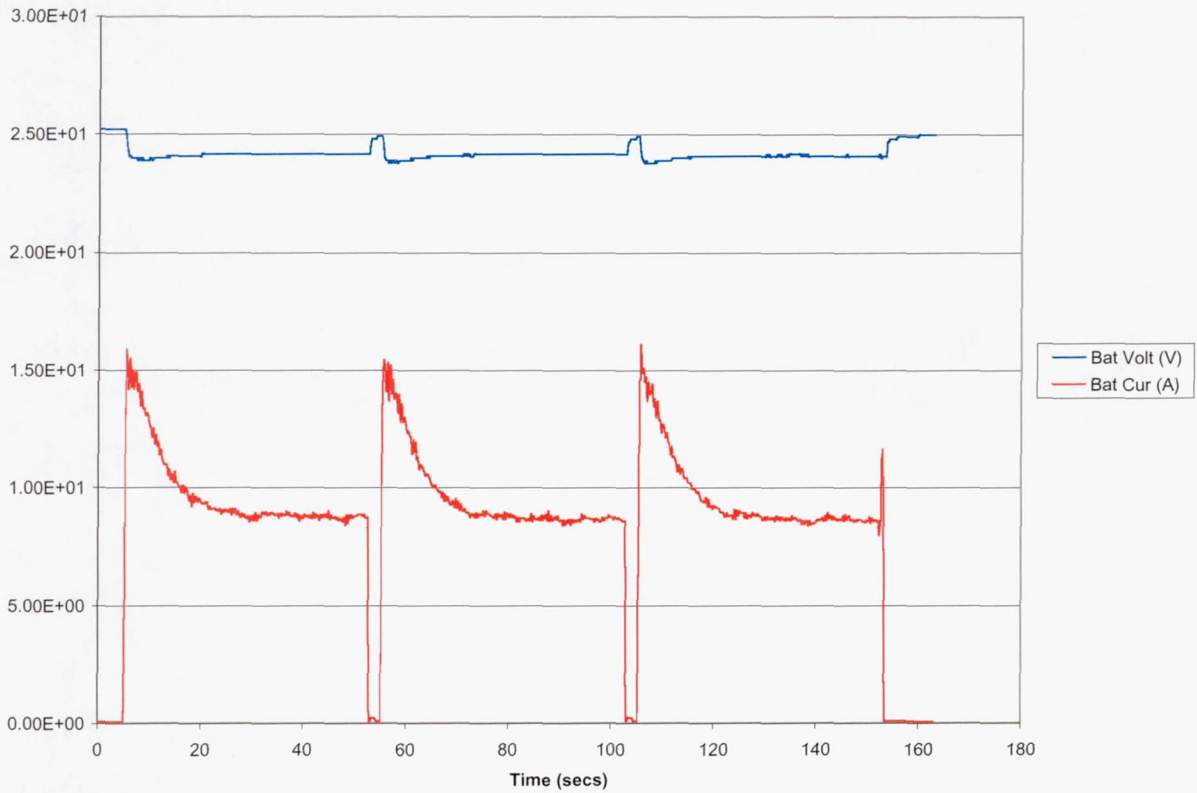

### Test 22: Stop Test, +4% Grade, Maximum Initial Speed, Normal Mode

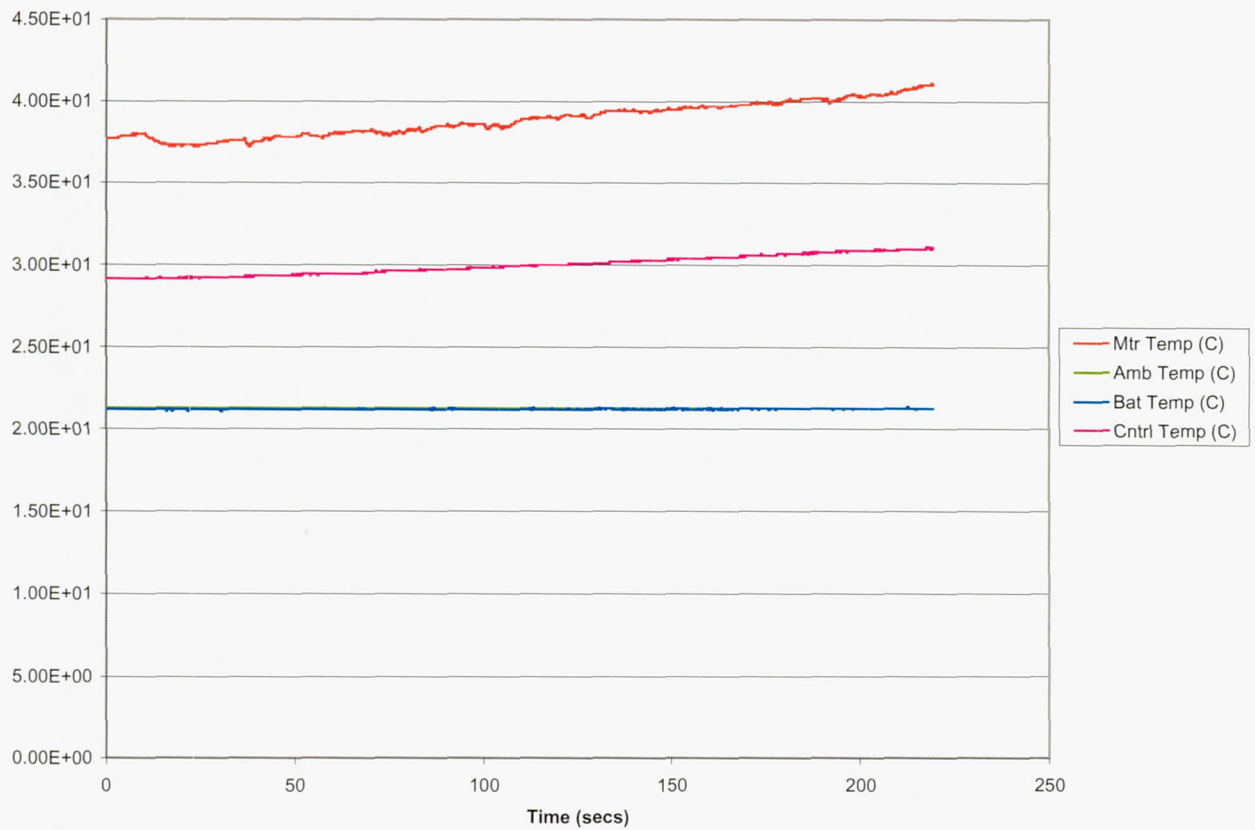
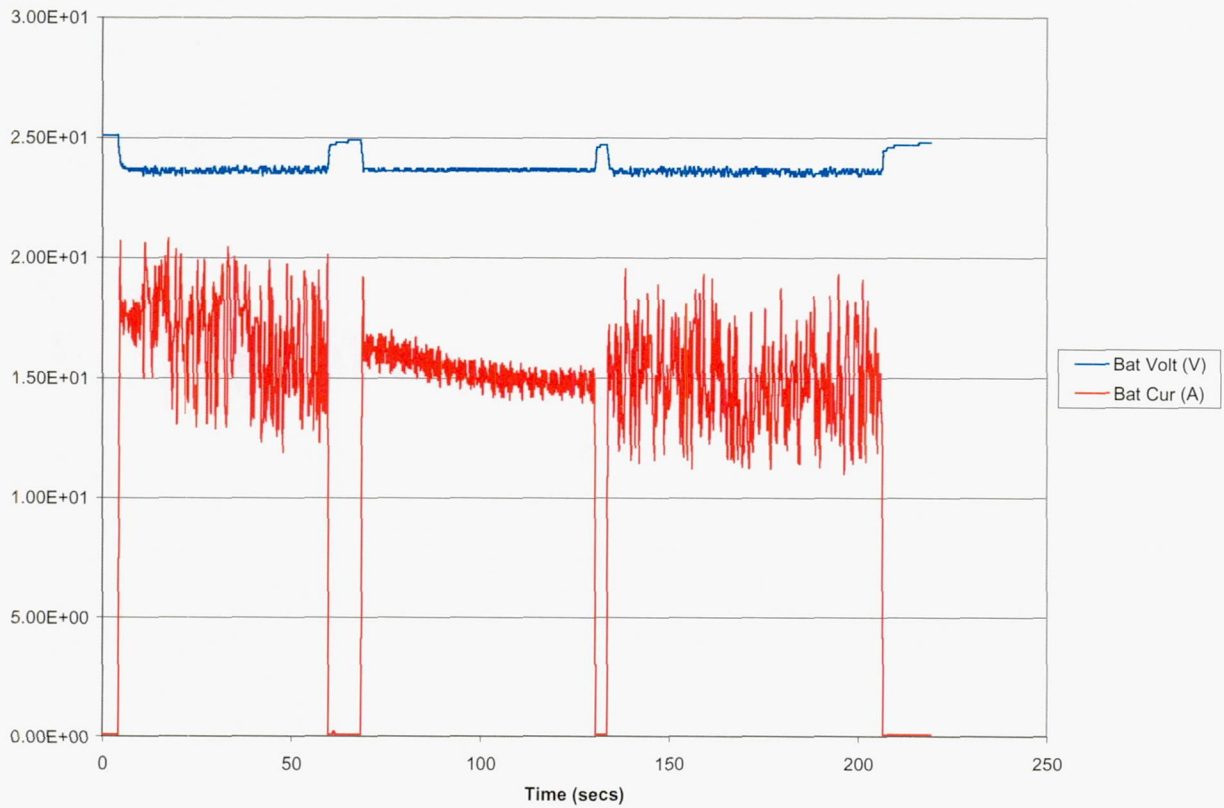

### Test 23: Stop Test, +4% Grade, Maximum Initial Speed, Economy Mode

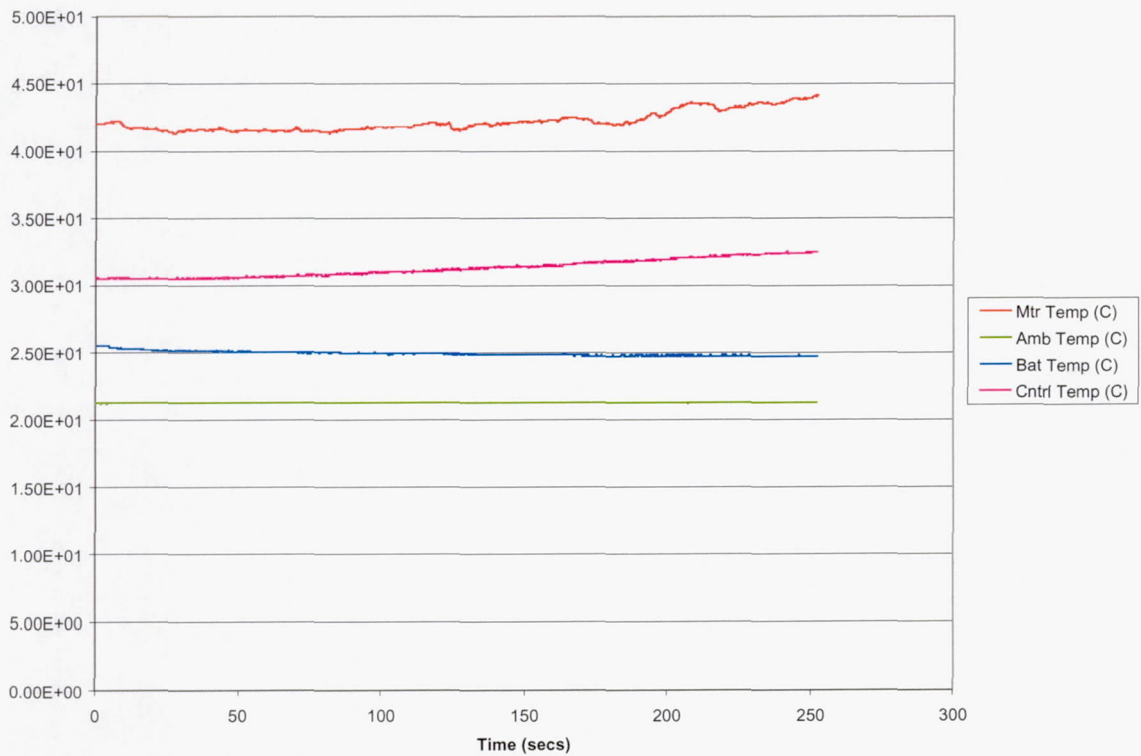
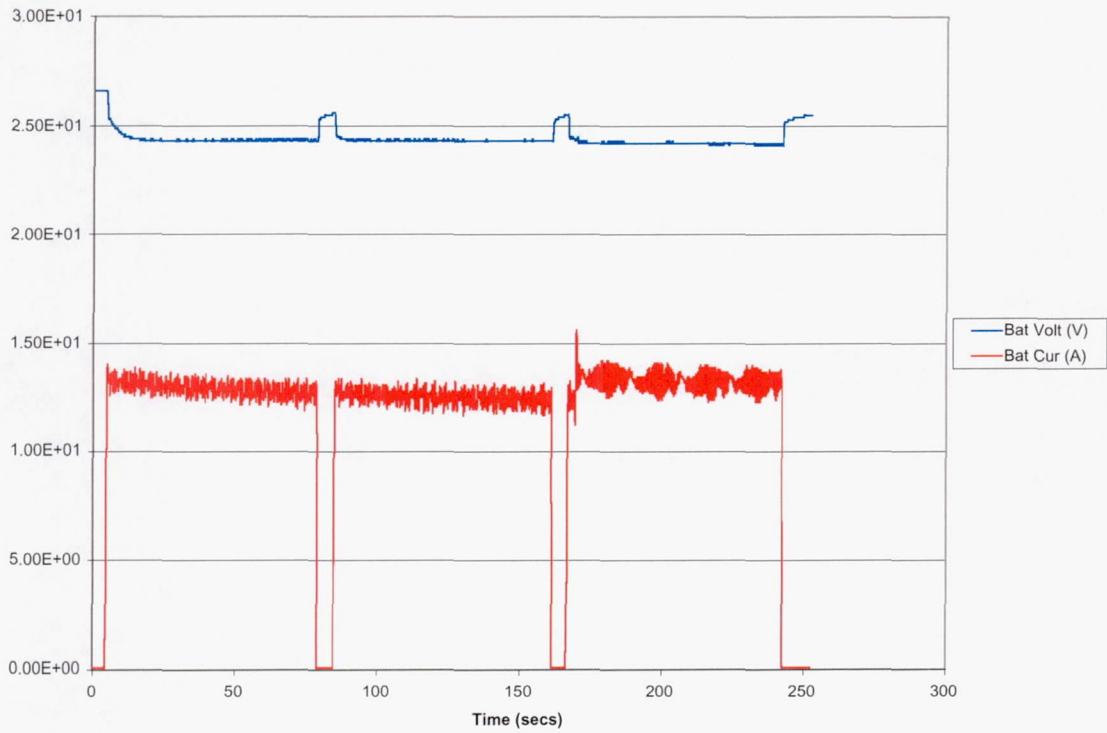

Test 24: Stop Test, +6% Grade, Maximum Initial speed, Normal Mode

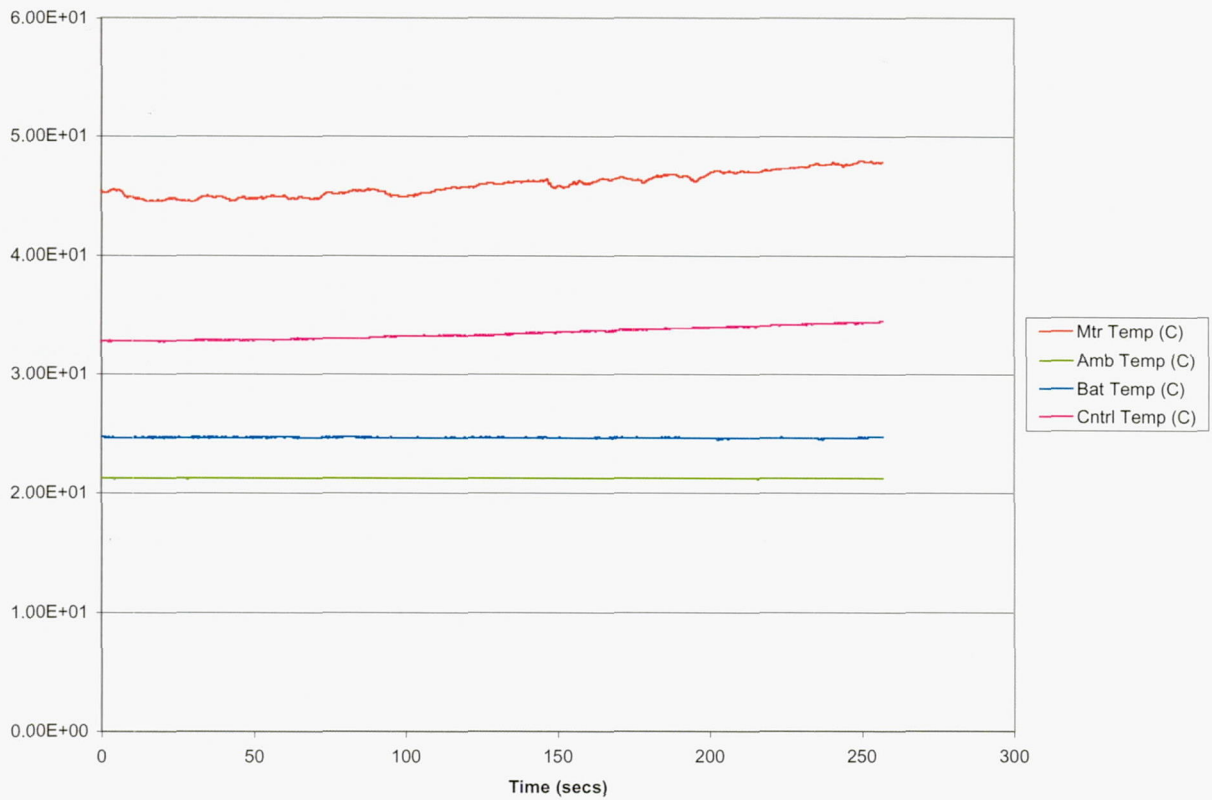
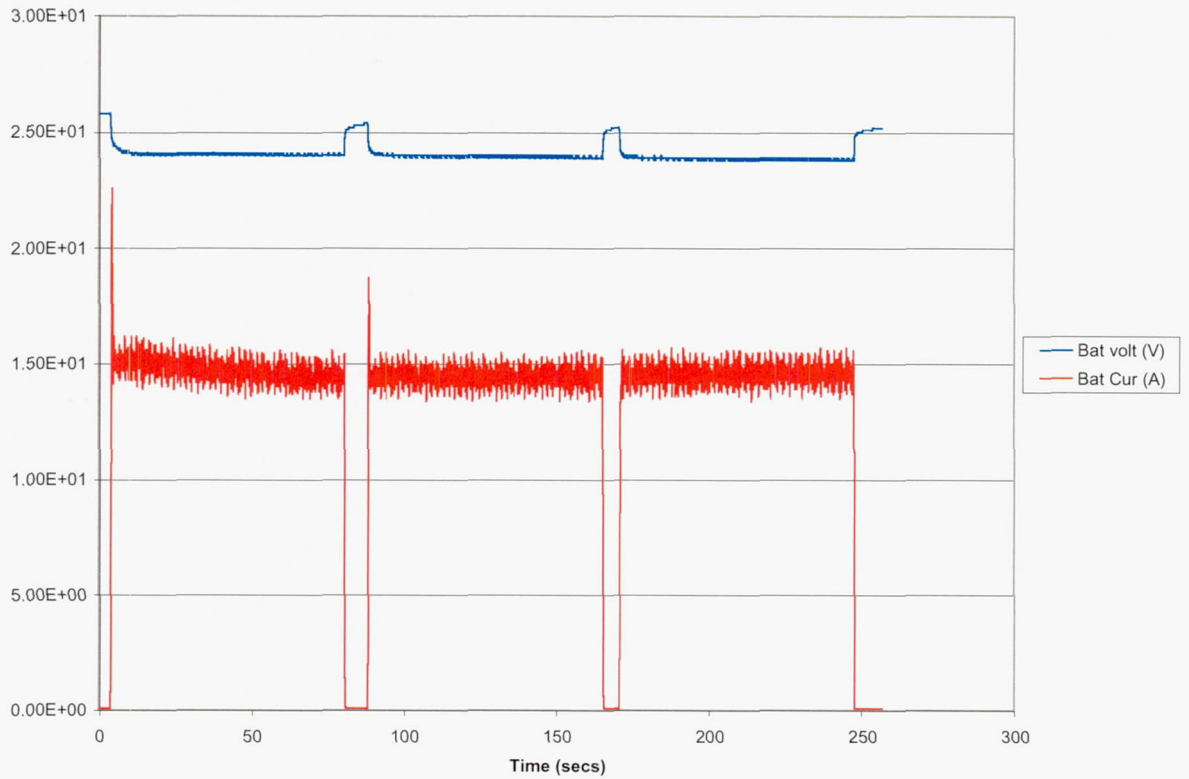

### Test 25: Stop Test, +6% Grade, Maximum Initial Speed, Economy Mode

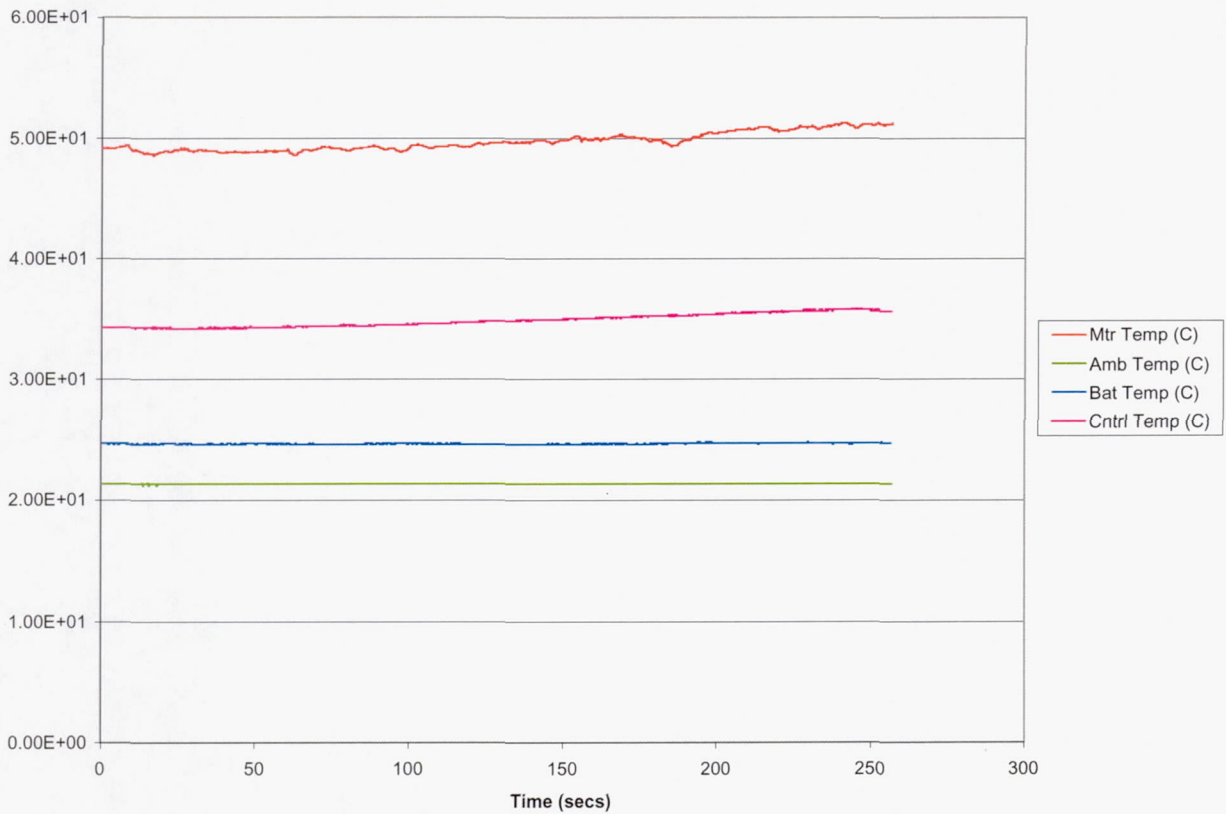
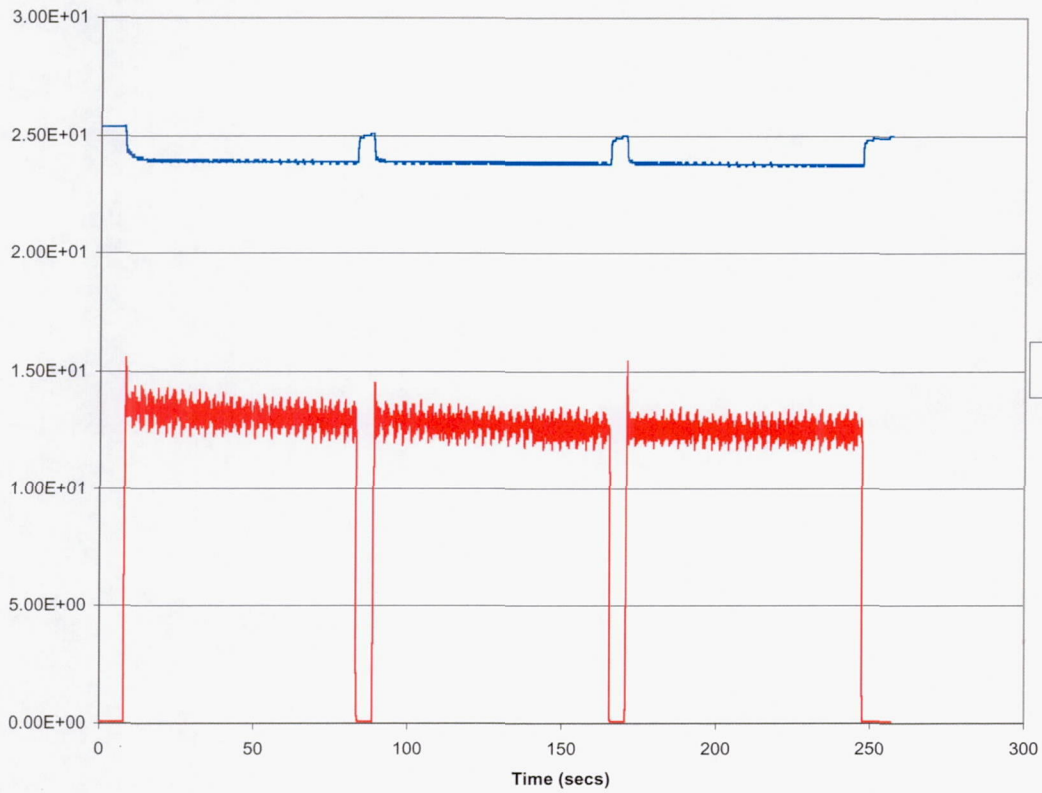

### Test 26: Stop Test, +8% Grade, Maximum Initial speed, Normal Mode

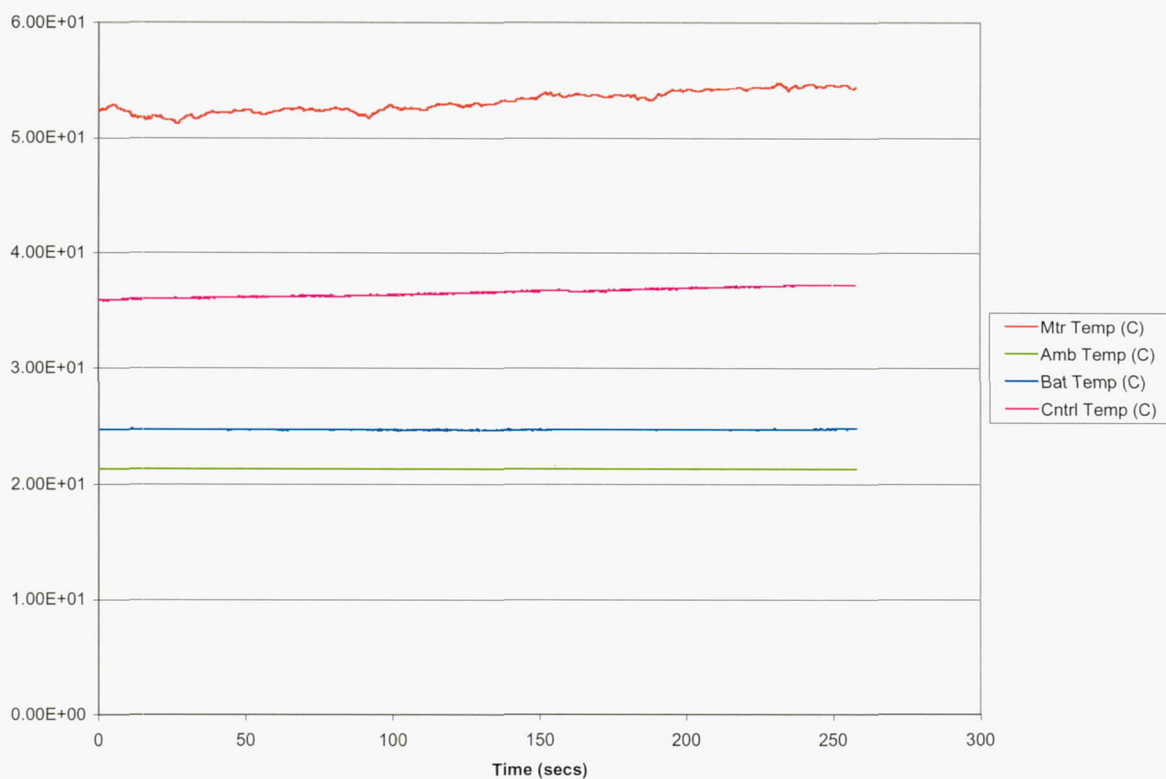
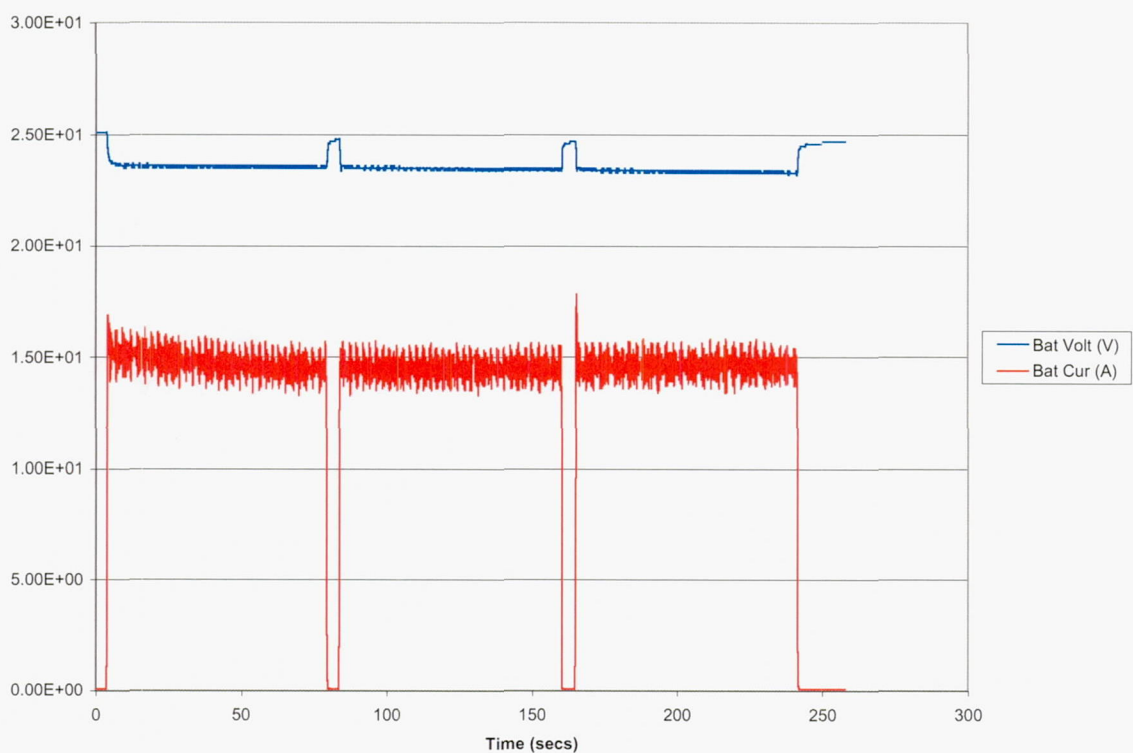

### Test 27: Stop Test, +8% Grade, Maximum Initial Speed, Economy Mode

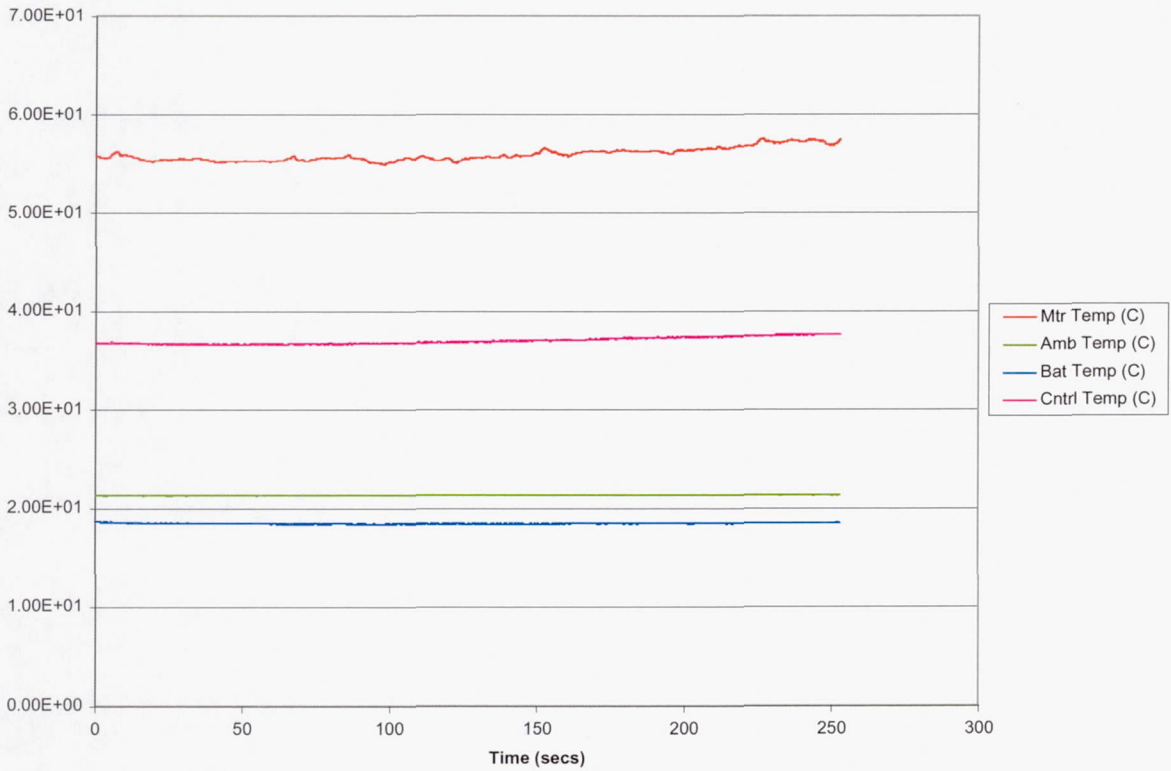
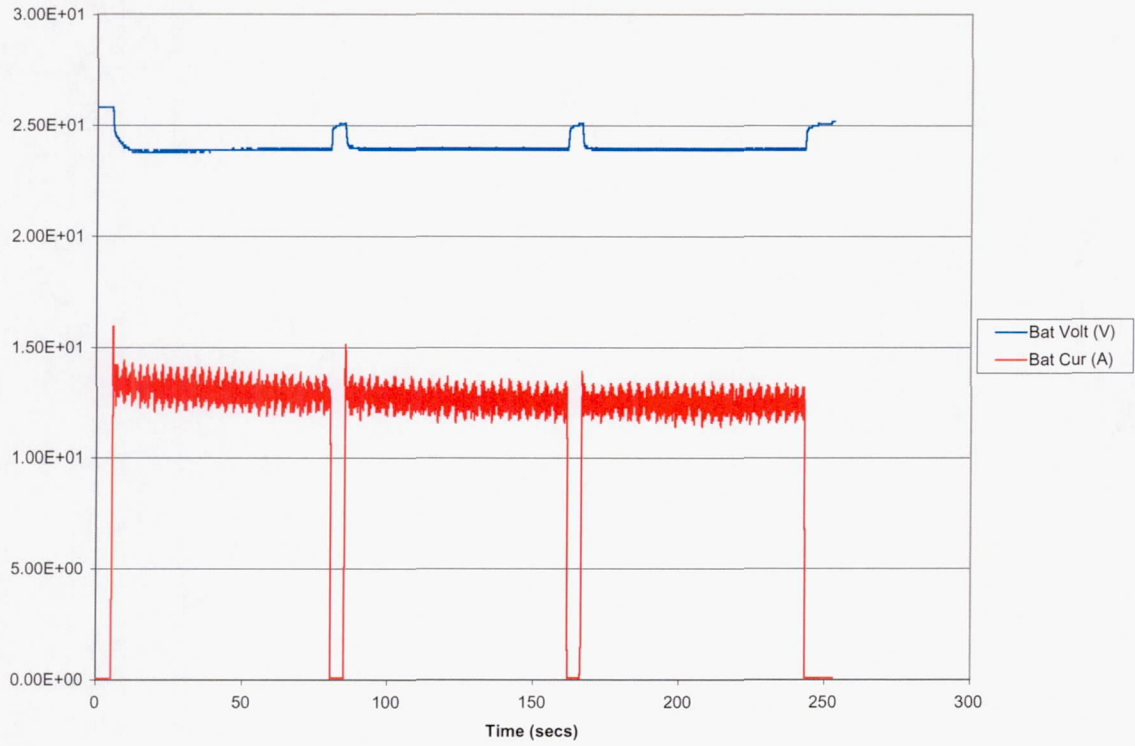

### Test 28: Battery Charging Test

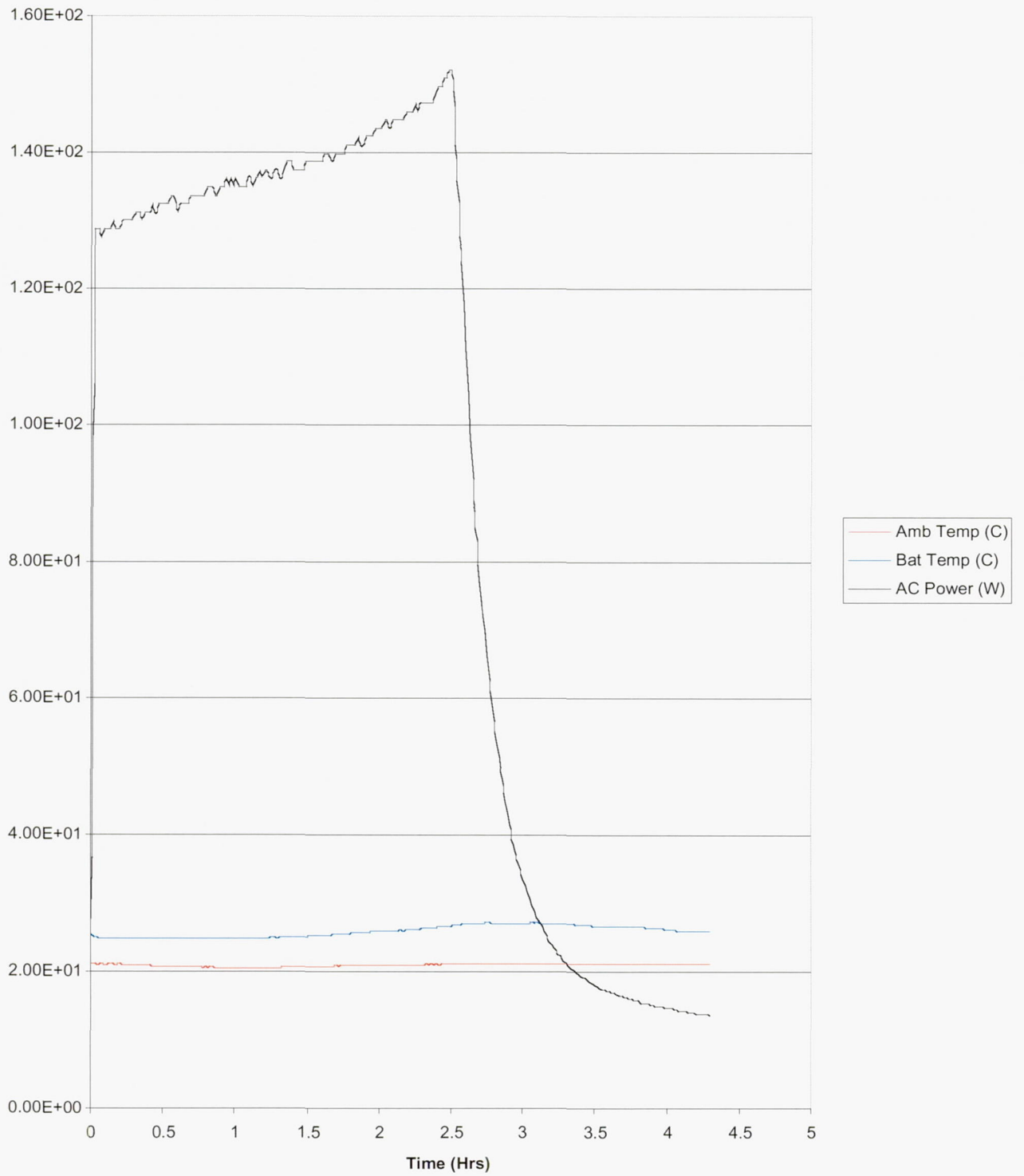

# REPORT DOCUMENTATION PAGE

Form Approved  
OMB No. 0704-0188

Public reporting burden for this collection of information is estimated to average 1 hour per response, including the time for reviewing instructions, searching existing data sources, gathering and maintaining the data needed, and completing and reviewing the collection of information. Send comments regarding this burden estimate or any other aspect of this collection of information, including suggestions for reducing this burden, to Washington Headquarters Services, Directorate for Information Operations and Reports, 1215 Jefferson Davis Highway, Suite 1204, Arlington, VA 22202-4302, and to the Office of Management and Budget, Paperwork Reduction Project (0704-0188), Washington, DC 20503.

1. AGENCY USE ONLY (Leave blank)	2. REPORT DATE January 2001	3. REPORT TYPE AND DATES COVERED Technical Memorandum	
4. TITLE AND SUBTITLE  Baseline Testing of the EV Global E-Bike		5. FUNDING NUMBERS  WU-251-30-07-00	
6. AUTHOR(S)  Dennis J. Eichenberg, John S. Kolacz, and Paul F. Tavernelli		8. PERFORMING ORGANIZATION REPORT NUMBER  E-12534	
7. PERFORMING ORGANIZATION NAME(S) AND ADDRESS(ES)  National Aeronautics and Space Administration John H. Glenn Research Center at Lewis Field Cleveland, Ohio 44135-3191		9. SPONSORING/MONITORING AGENCY NAME(S) AND ADDRESS(ES)  National Aeronautics and Space Administration Washington, DC 20546-0001	
9. SPONSORING/MONITORING AGENCY NAME(S) AND ADDRESS(ES)  National Aeronautics and Space Administration Washington, DC 20546-0001		10. SPONSORING/MONITORING AGENCY REPORT NUMBER  NASA TM-2001-210569	
11. SUPPLEMENTARY NOTES  Responsible person, Dennis J. Eichenberg, organization code 7720, 216-433-8360.			
12a. DISTRIBUTION/AVAILABILITY STATEMENT  Unclassified - Unlimited Subject Categories: 31, 33, and 37 Available electronically at <a href="http://gltrs.grc.nasa.gov/GLTRS">http://gltrs.grc.nasa.gov/GLTRS</a> This publication is available from the NASA Center for AeroSpace Information, 301-621-0390.		12b. DISTRIBUTION CODE  Distribution: Nonstandard	
13. ABSTRACT (Maximum 200 words)  The NASA John H. Glenn Research Center initiated baseline testing of the EV Global E-Bike as a way to reduce pollution in urban areas, reduce fossil fuel consumption and reduce operating costs for transportation systems. The work was done under the Hybrid Power Management (HPM) Program, which includes the Hybrid Electric Transit Bus (HETB). The E-Bike is a state of the art, ground up, hybrid electric bicycle. Unique features of the vehicle's power system include the use of an efficient, 400 W, electric hub motor, and a 7-speed derailleur system that permits operation as fully electric, fully pedal, or a combination of the two. Other innovative features, such as regenerative braking through ultracapacitor energy storage, are planned. Regenerative braking recovers much of the kinetic energy of the vehicle during deceleration. The E-Bike is an inexpensive approach to advance the state of the art in hybrid technology in a practical application. The project transfers space technology to terrestrial use via nontraditional partners, and provides power system data valuable for future space applications. A description of the E-bike, the results of performance testing, and future vehicle development plans is the subject of this report. The report concludes that the E-Bike provides excellent performance, and that the implementation of ultracapacitors in the power system can provide significant performance improvements.			
14. SUBJECT TERMS  Hybrid electric vehicle		15. NUMBER OF PAGES 60	
17. SECURITY CLASSIFICATION OF REPORT Unclassified		16. PRICE CODE A04	
18. SECURITY CLASSIFICATION OF THIS PAGE Unclassified	19. SECURITY CLASSIFICATION OF ABSTRACT Unclassified	20. LIMITATION OF ABSTRACT	