

INTERNATIONAL LASER RANGING SERVICE

1999

ANNUAL REPORT

May 2000

Edited by M. Pearlman
and L. Taggart

NASA/TP-2000-209969

The NASA STI Program Office ... in Profile

Since its founding, NASA has been dedicated to the advancement of aeronautics and space science. The NASA Scientific and Technical Information (STI) Program Office plays a key part in helping NASA maintain this important role.

The NASA STI Program Office is operated by Langley Research Center, the lead center for NASA's scientific and technical information. The NASA STI Program Office provides access to the NASA STI Database, the largest collection of aeronautical and space science STI in the world. The Program Office is also NASA's institutional mechanism for disseminating the results of its research and development activities. These results are published by NASA in the NASA STI Report Series, which includes the following report types:

- **TECHNICAL PUBLICATION.** Reports of completed research or a major significant phase of research that present the results of NASA programs and include extensive data or theoretical analysis. Includes compilations of significant scientific and technical data and information deemed to be of continuing reference value. NASA's counterpart of peer-reviewed formal professional papers but has less stringent limitations on manuscript length and extent of graphic presentations.
- **TECHNICAL MEMORANDUM.** Scientific and technical findings that are preliminary or of specialized interest, e.g., quick release reports, working papers, and bibliographies that contain minimal annotation. Does not contain extensive analysis.
- **CONTRACTOR REPORT.** Scientific and technical findings by NASA-sponsored contractors and grantees.
- **CONFERENCE PUBLICATION.** Collected papers from scientific and technical conferences, symposia, seminars, or other meetings sponsored or cosponsored by NASA.
- **SPECIAL PUBLICATION.** Scientific, technical, or historical information from NASA programs, projects, and mission, often concerned with subjects having substantial public interest.
- **TECHNICAL TRANSLATION.** English-language translations of foreign scientific and technical material pertinent to NASA's mission.

Specialized services that complement the STI Program Office's diverse offerings include creating custom thesauri, building customized databases, organizing and publishing research results . . . even providing videos.

For more information about the NASA STI Program Office, see the following:

- Access the NASA STI Program Home Page at <http://www.sti.nasa.gov/STI-homepage.html>
- E-mail your question via the Internet to help@sti.nasa.gov
- Fax your question to the NASA Access Help Desk at (301) 621-0134
- Telephone the NASA Access Help Desk at (301) 621-0390
- Write to:
NASA Access Help Desk
NASA Center for Aerospace Information
7121 Standard Drive
Hanover, MD 21076-1320

INTERNATIONAL LASER RANGING SERVICE

1999

ANNUAL REPORT

May 2000

Edited by M. Pearlman
and L. Taggart

Goddard Space Flight Center
Greenbelt, MD 20771 USA

NASA/TP-2000-209969

Available From:

NASA Center for Aerospace Information
7121 Standard Drive
Hanover, MD 21076-1320
Price Code: A17

National Technical Information Service
5285 Port Royal Road
Springfield, VA 22161
Price Code: A10

PREFACE

This 1999 Annual Report of the International Laser Ranging Service (ILRS) is comprised of individual contributions from ILRS components within the international geodetic community.

This report documents the work of the ILRS components from the inception of the Service through December 31, 1999. Since the Service has only recently been established, the ILRS associates decided to publish this Annual Report as a reference to our organization and its components.

All of the content of this Annual Report also appears on the ILRS website at:

http://ilrs.gsfc.nasa.gov/ilrsar_1999.html

This book and the website are organized as follows:

The first section of the Annual Report contains general information about the ILRS, its mission, structure and Governing Board. Professor Gerhard Beutler's introductory remarks and the ILRS Chairman's report give a brief background and history of the ILRS and an overview of its organization.

- Section 1, the Governing Board Report, provides an overview of the ILRS, a brief history of its origin and establishment, the contributions that it provides to the scientific community, its interface with other organizations and a view on future prospects.
- Section 2, the Central Bureau Report, provides reports on the current status of Central Bureau activities, mission priorities, network campaigns, upcoming missions, the ILRS website, Network performance evaluations and a report from the ILRS Science Coordinator.
- Section 3 includes the Working Group Reports, including accomplishments during the last year, and activities underway, as well as those planned for next year. The Working Groups have originated and developed many standards and procedures that have been implemented by the ILRS.
- Sections 4, 5 and 6 include Network, Operation Center and Data Center Reports. These sections provide the status of the data chain from the point of SLR data acquisition through archiving.
- Section 7 includes the Reports for the SLR Analysis and Associate Analysis Centers, as well as the LLR Analysis Centers. These reports include information on the data products generated by each, their computational capabilities and facilities, their personnel and their future plans.

The last section provides ILRS reference material: the Terms of Reference, a list of institutions contributing to this Annual Report, the list of ILRS Associate Members, a complete list of the ILRS components and a list of Acronyms.

The ILRS 1999 Annual Report will be a valuable reference for information about the ILRS and its components.

ACKNOWLEDGEMENTS

The editor would like to acknowledge the essential contributions of the following people to the preparation of the ILRS 1999 Annual Report:

- Carey Noll and Van Husson assembled many of the charts and figures for the report.
- Linda Taggart helped to edit the text and formatted and assembled the document.
- John Hazen designed the cover art and the layout for the color pages of the report.

Finally I would like to thank all of the ILRS colleagues who provided their contributions to the Annual Report.

Mike Pearlman
Secretary, ILRS Central Bureau

TABLE OF CONTENTS

Preface	i
Acknowledgements	iii
Table of Contents	v
Introduction to the 1999 ILRS Annual Report <i>coordinator: Gerhard Beutler</i>	ix
Chairperson's Remarks <i>John Degnan</i>	xi
About the ILRS	xv
ILRS Component Map	xviii
Governing Board Photos	xx
Section 1 - Governing Board Report <i>coordinator: John Degnan</i>	1
1.1 Overview of SLR	1
1.2 Origin and Establishment of the ILRS	4
1.3 Organization of the ILRS	5
1.4 Interface with Other Organizations	9
1.5 Current Status and Future Prospects	9
Section 2 - Central Bureau Report <i>coordinator: John Degnan</i>	15
2.1 Status and Activities of the Central Bureau <i>Mike Pearlman/John Bosworth</i>	16
2.2 Mission Priorities <i>Mike Pearlman</i>	19
2.3 Network Campaigns <i>Scott Wetzel/Mike pearlman</i>	20
2.4 Upcoming Missions <i>Scott Wetzel/Mike Pearlman</i>	28
2.5 ILRS Web Site <i>Van Husson</i>	36
2.6 Network Performance Evaluation <i>Van Husson</i>	39
2.7 ILRS Library <i>Mark Torrence</i>	40
2.8 Science Coordinator Report <i>Mark Torrence</i>	41
Section 3 - Working Group Reports <i>coordinators: John Degnan and Mike Pearlman</i>	45
3.1 Missions Working Group <i>Scott Wetzel/Hiroo Kunimori</i>	46
3.2 Networks and Engineering Working Group <i>Werner Gurtner</i>	51
3.3 Data Formats and Procedures Working Group <i>John Luck</i>	55

TABLE OF CONTENTS

3.4 Analysis Working Group	65
<i>Ron Noomen</i>	
3.5 Signal Processing Working Group	73
<i>Graham Appleby</i>	
Section 4 - Network Reports	81
<i>coordinator: Mike Pearlman</i>	
4.1 EUROLAS Network	82
<i>Georg Kirchner/Graham Appleby</i>	
4.2 NASA Network	98
<i>David Carter/Scott Wetzel</i>	
4.3 WPLTN Network	108
<i>Hiroo Kunimori</i>	
4.3.1 Introduction	108
4.3.2 Russian Network	110
<i>Natalia ParkHomenko</i>	
4.3.3 Chinese Network	115
<i>Yang Fumin</i>	
4.3.4 Australian Network	122
<i>John Luck</i>	
4.4 Lunar Network	126
<i>Peter Shelus</i>	
Section 5 - Operations Center Reports	131
<i>coordinator: Scott Wetzel</i>	
5.1 Mission Control Center	132
<i>Vladimir Glotov</i>	
5.2 NASA Goddard Space Flight Center	135
<i>David Carter/Scott Wetzel</i>	
5.3 University of Texas LLR Center	137
<i>Peter Shelus</i>	
Section 6 - Data Center Reports	141
<i>coordinator: Carey Noll</i>	
6.1 Global Data Centers	144
<i>Peter Shelus</i>	
6.1.1 CDDIS Report	144
<i>Carey Noll</i>	
6.1.2 EDC Report	148
<i>Wolfgang Seemueller</i>	
6.2 Regional Data Centers	151
6.2.1 Shanghai Data Center Report	151
<i>Zhang Zhongping</i>	

TABLE OF CONTENTS

Section 7 - Analysis Center Reports	155
<i>coordinators: Ron Noomen and Peter Shelus</i>	
7.1 Satellite Laser Ranging	157
<i>Peter Dunn</i>	
7.1.1 Analysis Centers	157
7.1.1.1 Center for Space Research	157
<i>Richard Eanes</i>	
7.1.1.2 Delft Analysis Center	164
<i>Ron Noomen</i>	
7.1.1.3 MCC Analysis Center	169
<i>Vladimir Glotov</i>	
7.1.2 Associate Analysis Center	173
7.1.2.1 FFI Associate Analysis Center	174
<i>Per Helge Andersen</i>	
7.1.2.2 DGFI Associate Analysis Center	175
<i>Detlef Angermann</i>	
7.1.2.3 NERC Associate Analysis Center	177
<i>Graham Appleby</i>	
7.1.2.4 ASI/CGS Associate Analysis Center	180
<i>Vincenza Luceri</i>	
7.1.2.5 GFZ Associate Analysis Center	183
<i>Franz-Heinrich Massmann</i>	
7.1.2.6 AUSLIG Associate Analysis Center	185
<i>Ramesh Govind</i>	
7.1.2.7 OCA/CERGA Associate Analysis Center	186
<i>Pierre Exertier</i>	
7.1.2.8 NASA GSFC's/JCET Associate Analysis Center	189
<i>Erricos Pavlis</i>	
7.1.2.9 IAA Associate Analysis Center	191
<i>Zinovy Malkin</i>	
7.1.2.10 AIUB Associate Analysis Center	194
<i>Tim Springer</i>	
7.1.2.11 BKG Associate Analysis Center	197
<i>Bernd Richter</i>	
7.2 Lunar Laser Ranging	198
<i>Peter Shelus</i>	
7.2.1 Introduction	198
<i>Peter Shelus</i>	
7.2.2 Analysis Centers	199
7.2.2.1 Paris Observatory	199
<i>Jean Chapront</i>	
7.2.2.2 FESG/TUM	204
<i>Jurgen Mueller</i>	

TABLE OF CONTENTS

7.2.2.3 Jet Propulsion Laboratory	208
<i>James Williams/Jean Dickey</i>	
7.2.2.4 University of Texas	210
<i>Judit Ries</i>	
Section 8 - ILRS Information.	217
<i>coordinators: Van Husson and Carey Noll</i>	
8.1 ILRS Terms of Reference	217
<i>Carey Noll</i>	
8.2 ILRS Website Reference Card	226
<i>Carey Noll</i>	
8.3 ILRS Website Map	228
<i>Van Husson</i>	
8.4 Network Performance Report Card for 1999	230
<i>Van Husson</i>	
8.5 ILRS Network Statistics	232
<i>Carey Noll</i>	
8.5.1 SLR Point Totals by Station for 1999	232
8.5.2 SLR Pass Totals by Station for 1999	236
8.6 ILRS Components	240
<i>Carey Noll</i>	
8.7 ILRS Participating Institutions.	242
<i>Carey Noll</i>	
8.8 ILRS Associates.	244
<i>Carey Noll</i>	
8.9 List of Acronyms.	249
<i>Carey Noll</i>	

THE ILRS:

A NEW APPROACH FOR THE WORLD-WIDE COORDINATION OF LASER TRACKING OF ARTIFICIAL SATELLITES AND OF THE MOON

Gerhard Beutler Vice-President of the International
Association of Geodesy (IAG)

When I was asked by Dr. Michael Pearlman to write a preface for the first annual report of the International Laser Ranging Service (ILRS) I was honored, but answered by asking Mike whether he knew that I was no longer President of CSTG and thus had "nothing whatsoever to do with the ILRS service". I thought he might ask me to say few words "on behalf of IAG" as its newly elected Vice-President. Dr. Michael Pearlman replied "oh, you know, you still are the ILRS uncle, and we have your picture pinned at the wall". I thus try to say a few words as an uncle and as Vice-President of IAG. The two roles are, by the way, not mutually exclusive.

Most of my colleagues believe that my background is in GPS. I have to confess, however, that I was heavily involved in Satellite Laser Ranging (SLR) between 1976 and 1983, when we tried to build up what was called at that time the "new" SLR Observatory in Zimmerwald. It is remarkable that the success only came one year after I had left, when my colleague, Prof. Werner Gurtner, took over the position as manager of the Zimmerwald observatory.

I learned several things from my personal engagement in the stimulating environment of SLR: First, I understood, that my professional skills were more in the area "mathematical methods, theory, etc" and less in technology oriented, operational and organizational matters. I was therefore glad to find a new challenge in developing algorithms for processing GPS observations.

Secondly, I learned that in the era of space geodesy Laser ranging is the only calibration method for the other modern space geodetic techniques because in the optical and near infrared domain of the electromagnetic spectrum the signal delays due to the Earth's atmosphere may be taken into account on the level of one centimeter or better, provided pressure, temperature and humidity are continuously monitored at the SLR/LLR tracking sites.

This must be seen in contrast to the VLBI technique and precise satellite microwave systems (GPS, GLONASS, DORIS, etc.) using

the microwave part of the spectrum, where tropospheric refraction may be taken into account (using the same surface met data) only on the level of about 10cm. For regional and global applications VLBI, GPS, etc. only achieve accurate results thanks to highly sophisticated troposphere modeling techniques.

The SLR observation on the other hand "only" relies on

- the assumption of the constancy of the speed of light in vacuum (where I am a bit concerned that people only know the least significant three digits "458")
- modern Laser technology producing very short (50-100 picoseconds) light pulses of a very small divergence,
- the assumption that the satellite (artificial or natural) is equipped with one or more retroreflectors sending the light back into the incident direction, and
- extremely accurate time interval counters allowing to measure the light traveling time with picosecond resolution.

The first "assumption" actually is one of the best established laws of nature — it is the basis for the theory of relativity and it is even used to define the meter via the second in the SI-system. The remaining three assumptions are well taken care of by state of the art technology.

The SLR/LLR observation is easily understood and interpreted: Half of the light traveling time (after subtraction of the atmospheric signal delay) is the geometrical distance between observatory and satellite at reflection time of the signal at the satellite. The single shot observation is unbiased and accurate to about one centimeter. Higher accuracies are achievable through normal point techniques.

Everybody knows that the investments on ground for SLR and/or LLR tracking are substantial. The investments in the space segment are minor, however. This is an important argu-

ment to keep SLR tracking alive as an accurate backup orbit determination tool.

Laser Ranging is a comparatively old space geodetic observation technique. We owe it much and deep insight in geodesy and geophysics: Our knowledge of the Earth gravity field is to a great extent due to SLR observations. The motion of the moon is known with unprecedented accuracy thanks to LLR, yielding among other, the best test basis for different gravity theories. SLR and VLBI together were the observation techniques of the 1980s leading to the first accurate realization of the global ITRF, the International Terrestrial Reference Frame.

With the advent and the success of the GPS in space geodesy, for scientific applications coordinated by the IGS, the International GPS Service, a heavy pressure was exerted on the SLR/LLR and the VLBI communities: It was argued that the new satellite microwave systems could provide in a much cheaper way the entire spectrum of parameters of geodetic and geophysical interest than the traditional techniques — of course without mentioning that the SLR-derived gravity field was an absolute prerequisite for success of IGS.

Counterarguments were, as indicated, readily at hand. It was also obvious, however, that the older techniques had to learn from the newly created IGS: Only if SLR/LLR (and the VLBI) products would be made regularly available with short delays after the observation and in a format common to all techniques, the "routine" SLR tracking would be able to contribute significantly to space geodetic time series in future, as well.

Mid of the 1990s the SLR/LLR community started considering the replacement of its CSTG subcommission by an international organization comparable to the IGS. The tenth International Workshop on Laser Ranging Instrumentation in Shanghai, China (November 11-15, 1996) may be viewed as the starting point for the development of the ILRS: An open and general discussion including all participants of the workshop revealed that the SLR/LLR community was determined to

move into the direction of a more product-driven and service-oriented organization. At the Shanghai meeting of the CSTG Subcommission SLR/LLR the decision was taken to write Terms of Reference for the new organization. A group led by John Degnan, SLR/LLR subcommission president at that time, started working immediately. The Terms of Reference and a Call for Participation were written in less than six months. Both documents were accepted first by the CSTG Executive committee, then by the IERS, finally by the IAG Executive Committee in 1997. The Call for Participation was sent out on 28 January 1998. The success was overwhelming: The entire SLR and LLR community joined the effort. In fall 1998 the new service started operating.

It is remarkable that the structure of international SLR and LLR cooperation could be revised and put on a completely new basis within only two years. The CSTG Subcommission and the ILRS Governing Board, their President and secretary, Drs. John Degnan and Michael Pearlman, and the entire SLR and LLR community must be congratulated for this achievement. The creation of the International Laser Ranging Service ILRS must be considered as a great success story in space geodesy. It gained a lot of new momentum for this proud space geodetic technique.

The first Annual Report of the ILRS documents that the initial phase of the ILRS was very satisfactory as well. On behalf of IAG and its Executive Committee I would like to thank the ILRS Governing Board and the entire community for their work.

Let me conclude by wishing the ILRS many fruitful years and informative annual reports. If the ILRS preserves the spirit governing its creation and its initial operational phase I have no doubt that the community is well prepared to meet the challenges of the future, as well. The community knows that the planetary systems is in reach of the Laser Ranging Technique — one "only" has to replace the laser reflectors by optical transponder systems and the targets by planets ...

CHAIRMAN'S REMARKS

The International Laser Ranging Service (ILRS) was created on 22 September 1998 at the 11th International Workshop on Laser Ranging in Deggendorf, Germany. The Central Bureau (CB) was established at the NASA Goddard Space Flight Center with John Bosworth and Mike Pearlman respectively serving as Director and Secretary. The first ILRS General Assembly coincided with the final meeting of the predecessor CSTG Subcommittee on Satellite and Lunar Laser Ranging, which I had the honor of chairing for several years. The newly elected Governing Board was installed, and various members were chosen to serve as Coordinators and Deputy Coordinators for the four standing Working Groups (WG's) - Missions, Data Formats and Procedures, Networks and Engineering, and Analysis. In July 1999, the ILRS was elevated to the rank of an IAG Service by the IAG Directing Board, on an equal footing with the established International GPS Service (IGS) and the newly created International VLBI Service (IVS), with close ties and representation on the International Earth Rotation Service (IERS) Directing Board.

In creating the structure for the new ILRS, the WG's were intended to be the focal points for most Governing Board activities and are now being emulated in the other space geodetic services. The WG's recommend policy or actions in their areas of responsibility which are then voted on by the full Governing Board. They are also responsible for recommending and/or providing additional materials to the CB for inclusion

in the knowledge databases. Although the WG concept is a carryover from the old CSTG SLR/LLR Subcommittee, it is my perception that the implementation and effectiveness of the WG's has been greatly enhanced in the new organization. This is due to several factors including the leadership of the GB Coordinators and Deputy Coordinators in formulating and carrying out action plans and attracting high caliber researchers to serve on the WG's, some of whom directly support the CB. This close coupling of the Governing Board, the Working Groups, and the Central Bureau has allowed rapid progress to be made during our first 18 months of operation. ILRS Associates who wish to volunteer their time or ideas are encouraged to contact the appropriate WG Coordinator.

In preparing this first Annual Report of the ILRS, we felt that it would be useful to include some fundamental information on the history, organization, and services provided by the ILRS. We hope that you will find it to be a useful reference in the future. Our Secretary, Mike Pearlman, is to be specially commended for his doggedness in bringing it all together.

We also wish to give special thanks to Linda Taggart of Raytheon ITSS for her tremendous effort in working with Mike on the editing and assembly of this document.

Finally, all ILRS Associates and Correspondents are encouraged to visit the ILRS Web Site at <http://ilrs.gsfc.nasa.gov> where you will see the fruits of our early labors first hand.

John J. Degnan
ILRS Governing Board Chairperson
Code 920.3, Geoscience Technology Office
NASA Goddard Space Flight Center
Greenbelt, MD 20771 USA

ABOUT ILRS

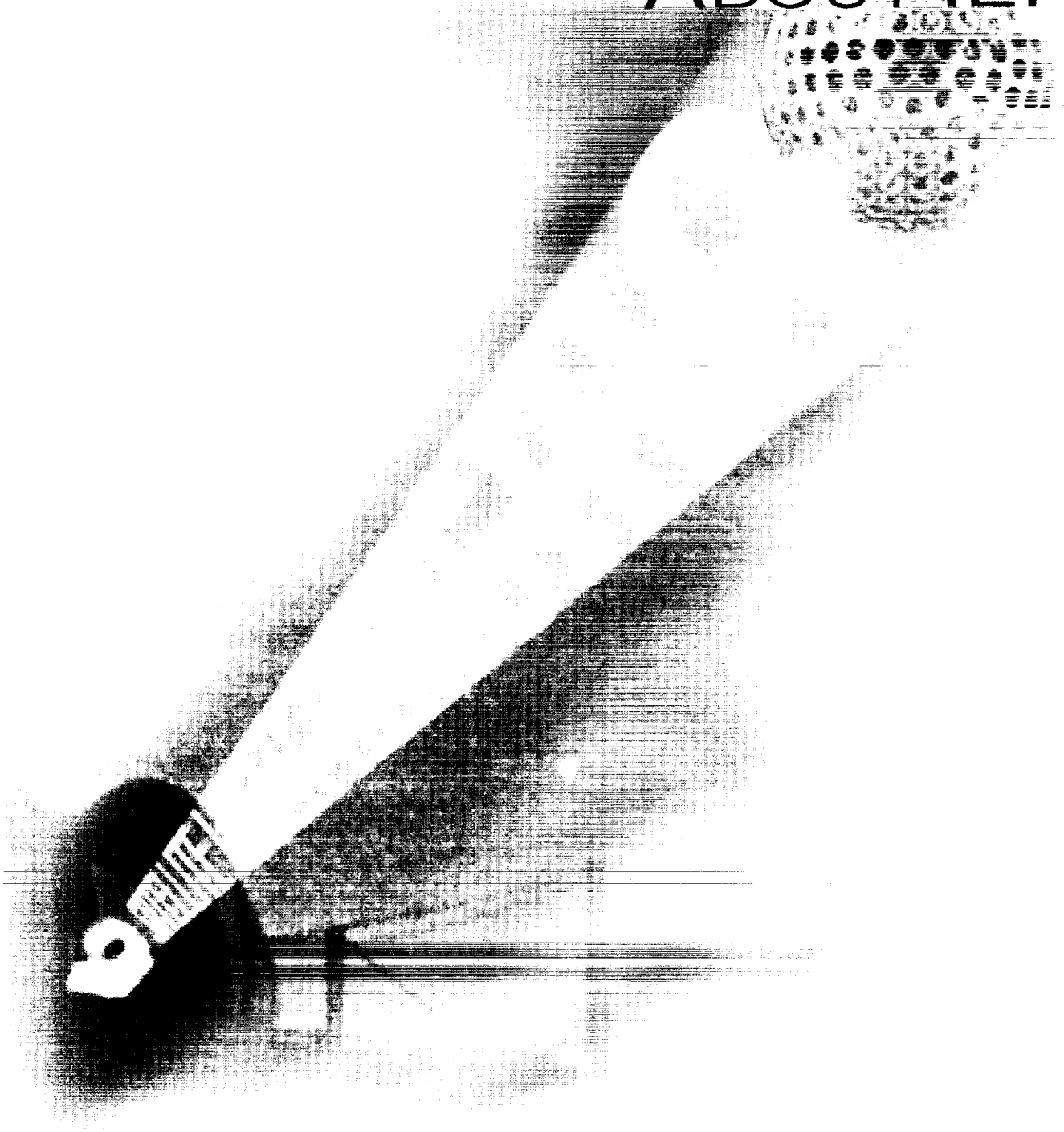

ILRS ORGANIZATION

Mission:

The International Laser Ranging Service (ILRS) organizes and coordinates Satellite Laser Ranging (SLR) to support programs in geodetic, geophysical and lunar research activities and provides the International Earth Rotation Service (IERS) with products important to the maintenance of an accurate International Terrestrial Reference Frame (ITRF).

Role:

ILRS is a service of the International Association of Geodesy (IAG), originally established under IAG Commission VIII—the International Coordination of Space Techniques for Geodesy and Geodynamics (CSTG).

ILRS is the second of this type of service to be established. The first was the IGS (International GPS Service) which has been highly successful as a service for GPS.

The ILRS develops (1) the standards and specifications necessary for product consistency and (2) the priorities and tracking strategies required to maximize network efficiency. The service collects, merges, analyzes, archives and distributes satellite and lunar ranging data to satisfy a variety of scientific engineering and operational needs and encourages the application of new technologies to enhance the quality, quantity and cost effectiveness of its data products. The ILRS works with (1) new satellite missions in the design and building of retroreflector targets to maximize data quality and quantity and (2) science programs to optimize scientific data yield.

The basic observable is the precise time-of-flight of an ultra-short laser pulse to and from a satellite, corrected for atmospheric delays. These data sets are used by the ILRS to generate a number of fundamental data products, including:

- Centimeter accuracy satellite ephemerides
- Earth orientation parameters (polar motion and length of day)
- Three-dimensional coordinates and velocities of the ILRS tracking stations
- Time-varying geocenter coordinates
- Static and time-varying coefficients of the Earth's gravity field
- Fundamental physical constants
- Lunar ephemerides and librations
- Lunar orientation parameters

All ILRS data and products are archived and are publically available.

The organizations listed in Section 8.7 contribute to the ILRS by supporting one or more ILRS components.

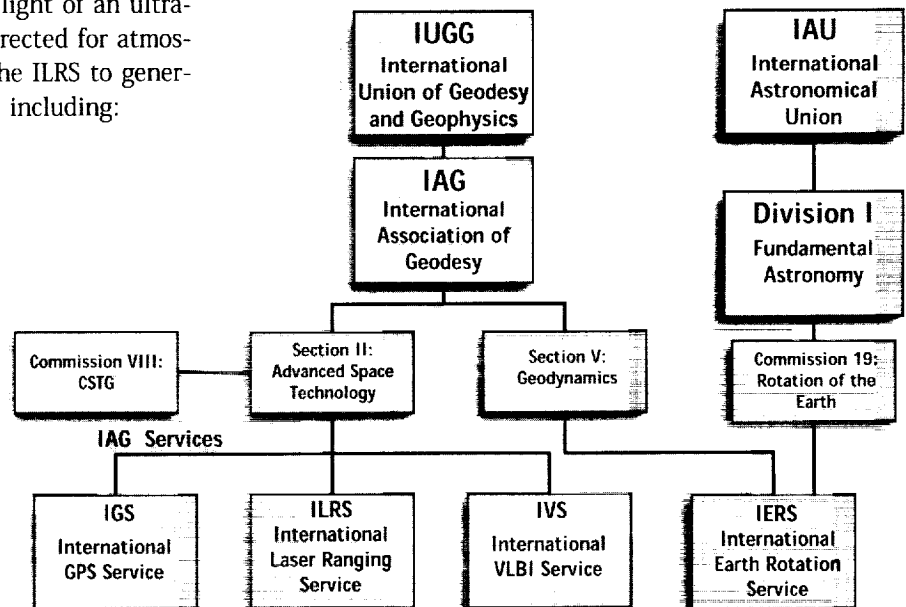

Structure:

The ILRS is organized into permanent components:

- a Governing Board,
- a Central Bureau,
- Tracking Stations and Subnetworks,
- Operations Centers,
- Global and Regional Data Centers and
- Analysis, Lunar Analysis and Associate Analysis Centers.

The Governing Board, with broad representation from the international SLR and LLR community, provides overall guidance and defines service policies, while the Central Bureau oversees and coordinates the daily service activities, maintains scientific and technological databases and facilitates communications. Active Working Groups in (1) Missions, (2) Networks and Engineering, (3) Data Formats and Procedures, (4) Analysis and (5) Signal Processing provide key operational and technical expertise to better exploit current capability and to challenge the ILRS participants to keep pace with evolving user needs. The ILRS currently includes more than 40 SLR stations, routinely tracking about 20 retroreflector-equipped satellites and the Moon in support of user needs.

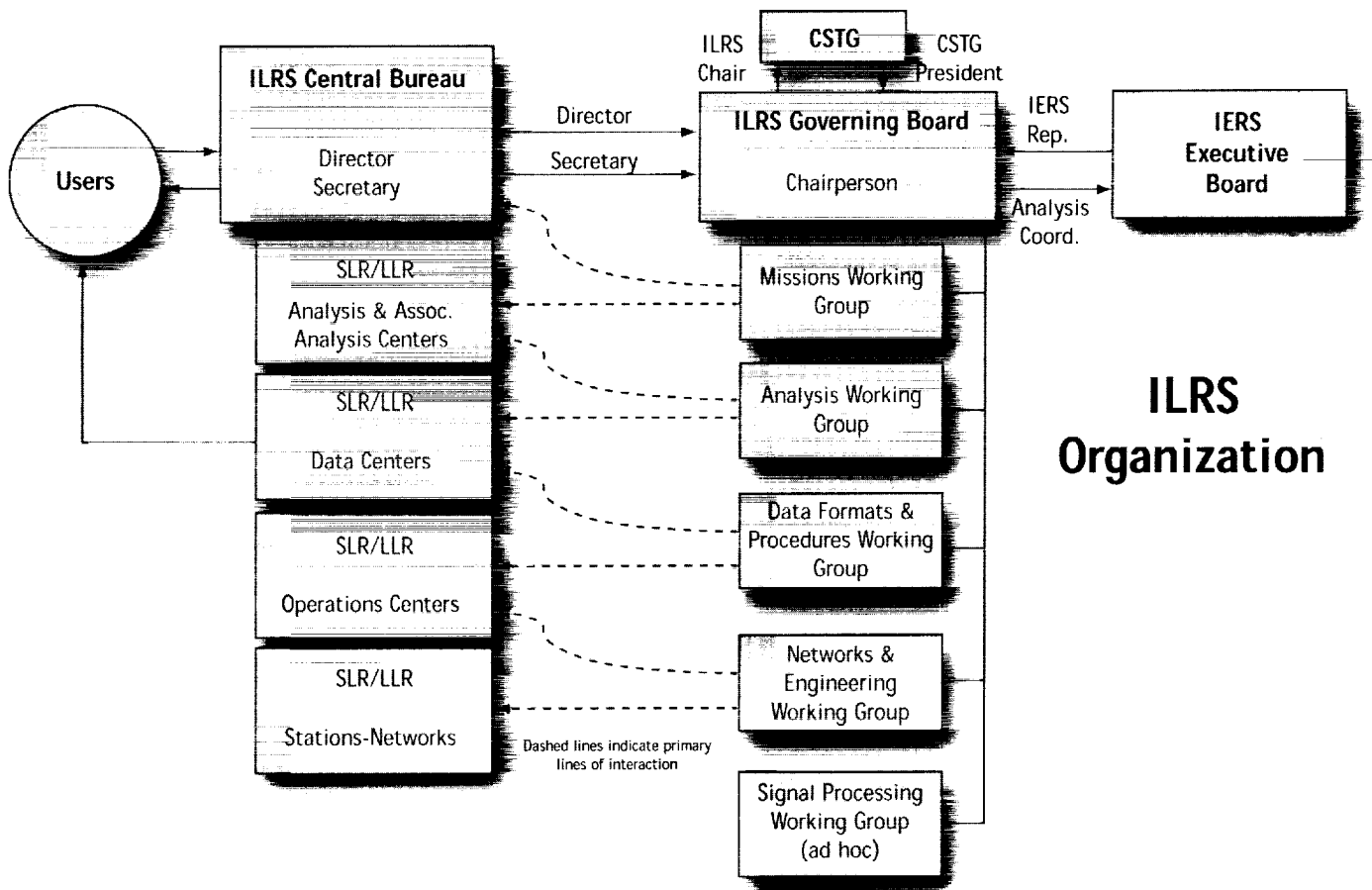

This Page Deliberately Left Blank

ILRS COMPONENT MAP

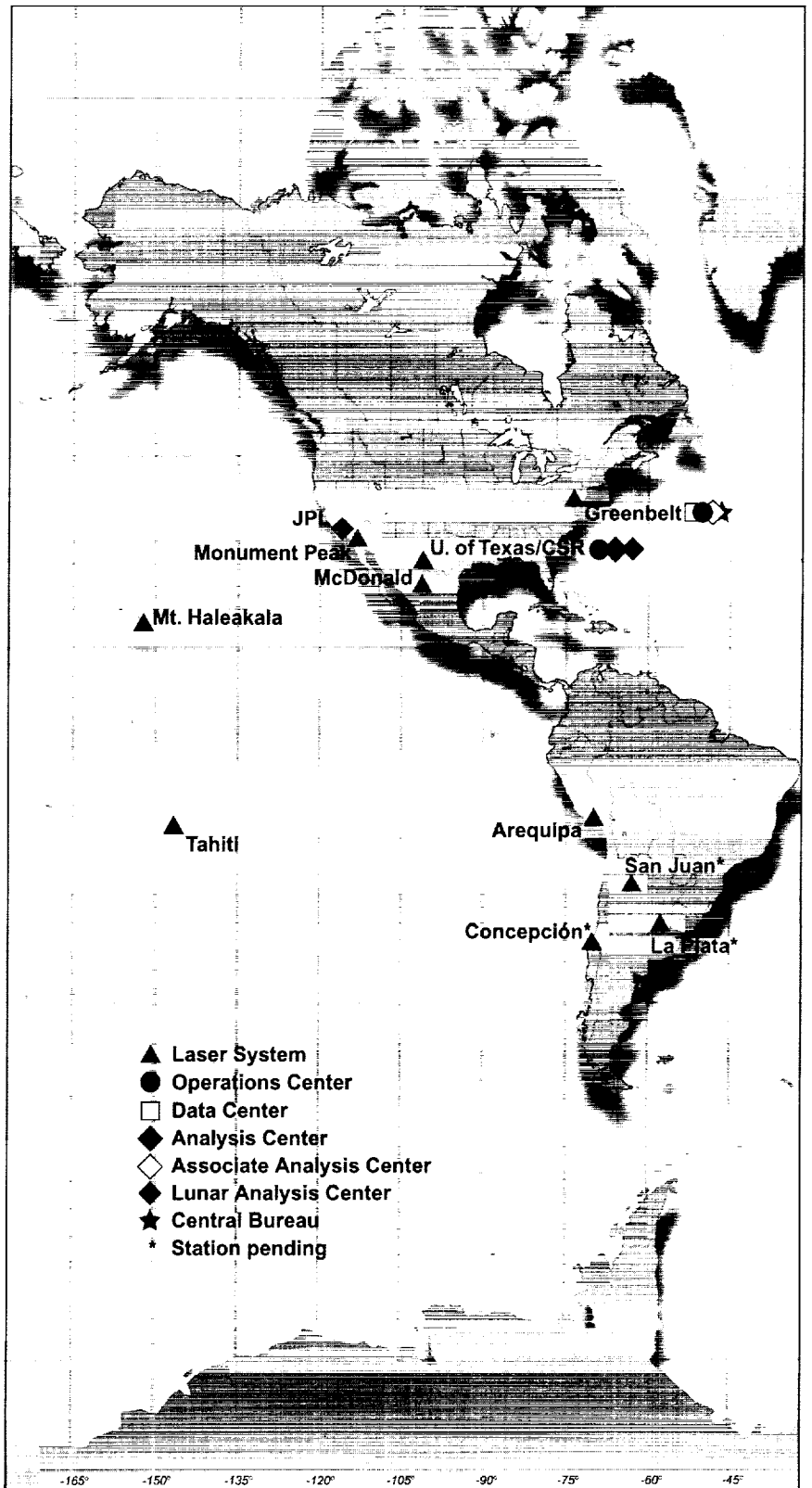

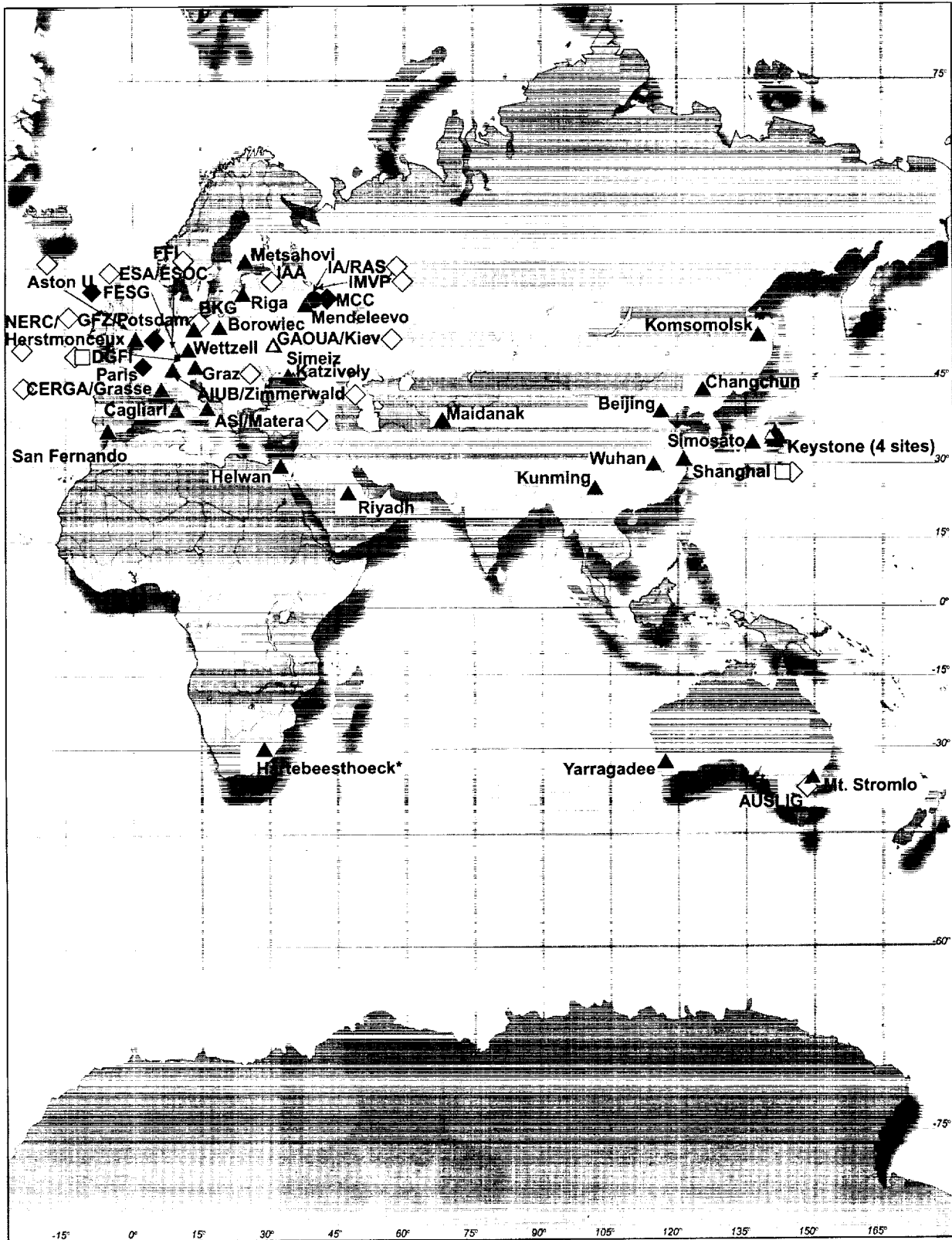

GOVERNING BOARD

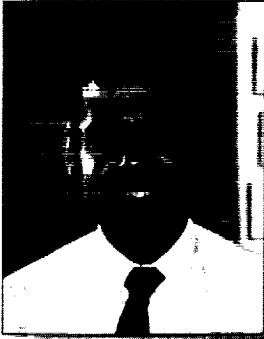

NAME: Herman Drewes
POSITION: Ex-Officio, CSTG
President
AFFILIATION: Deutsches
Geodätisches
Forschungsinstitut, Germany

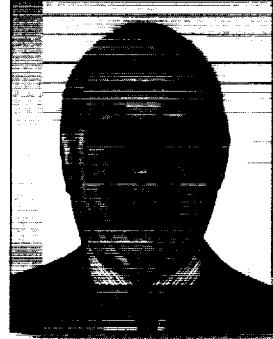

NAME: John Bosworth
POSITION: Ex-Officio, ILRS
Central Bureau
AFFILIATION: NASA Goddard
Space Flight Center, USA



NAME: Michael Pearlman
POSITION: Ex-Officio, Secretary,
ILRS Central Bureau
AFFILIATION : Harvard-
Smithsonian Center for
Astrophysics, USA

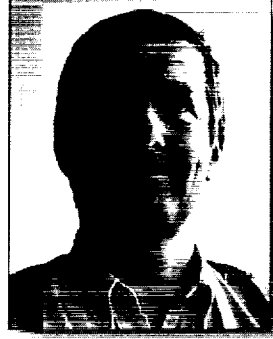

NAME: Werner Gurtner
POSITION: Appointed, EUROLAS,
Networks & Engineering
Working Group Coordinator
AFFILIATION: Astronomical
Institute of Berne,
Switzerland



NAME: Wolfgang Schlüter
POSITION: Appointed, EUROLAS,
Networks & Engineering
Working Group Deputy
Coordinator
AFFILIATION: Bundsamt für
Kartographie und Geodäsie,
Germany

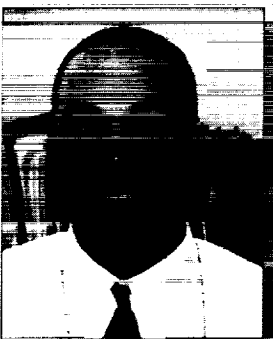

NAME: David Carter
POSITION: Appointed, NASA
AFFILIATION : NASA Goddard
Space Flight Center, USA

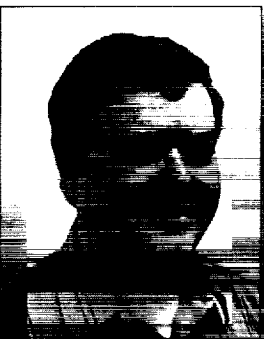

NAME: John Degnan
POSITION: Appointed, NASA,
Governing Board
Chairperson
AFFILIATION : NASA Goddard
Space Flight Center, USA



NAME: Yang Fumin
POSITION: Appointed, WPLTN
AFFILIATION : Shanghai
Observatory, Peoples
Republic of China



NAME: Hiroo Kunimori
POSITION: Appointed, WPLTN, Missions Working Group Coordinator
AFFILIATION: Communications Research Laboratory, Japan

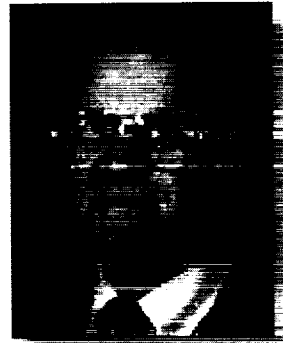

NAME: Bob Shutz
POSITION: Appointed, IERS Representative to ILRS
AFFILIATION: Center for Space Research, University of Texas, USA



NAME: Richard Eanes
POSITION: Elected, Analysis Representative
Affiliation: Center for Space Research, University of Texas, USA

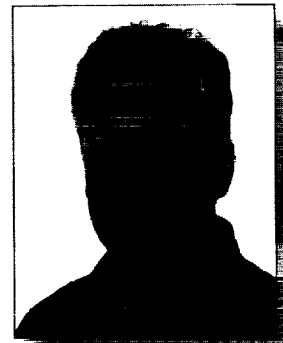

NAME: Ron Noomen
POSITION: Elected, Analysis Rep., Analysis Working Group Coordinator
AFFILIATION: Delft University of Technology, The Netherlands



NAME: Wolfgang Seemueller
POSITION: Elected, Data Centers Representative, Data Formats & Procedures Working Group Deputy Coordinator
AFFILIATION: Deutsches Geodätisches Forschungsinstitut, Germany

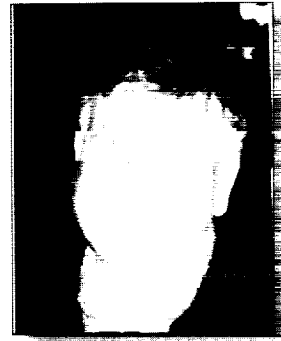

NAME: Peter Shelus
POSITION: Elected, Lunar Rep., Analysis Working Group Deputy Coordinator
AFFILIATION: University of Texas at Austin, USA



NAME: Francois Barlier
POSITION: Elected, At-Large, Missions Working Group Deputy Coordinator
AFFILIATION: Centre d'Études et de Recherches Géodynamiques et Astrométrie, France

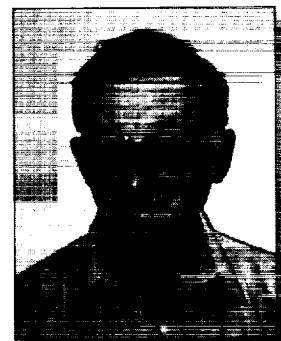

NAME: John Luck
POSITION: Elected, At-Large, Data Formats & Procedures Working Group Coordinator
AFFILIATION: Australian Surveying and Land Information Group, Australia

This Page Deliberately Left Blank

SECTION 1

GOVERNING BOARD REPORT



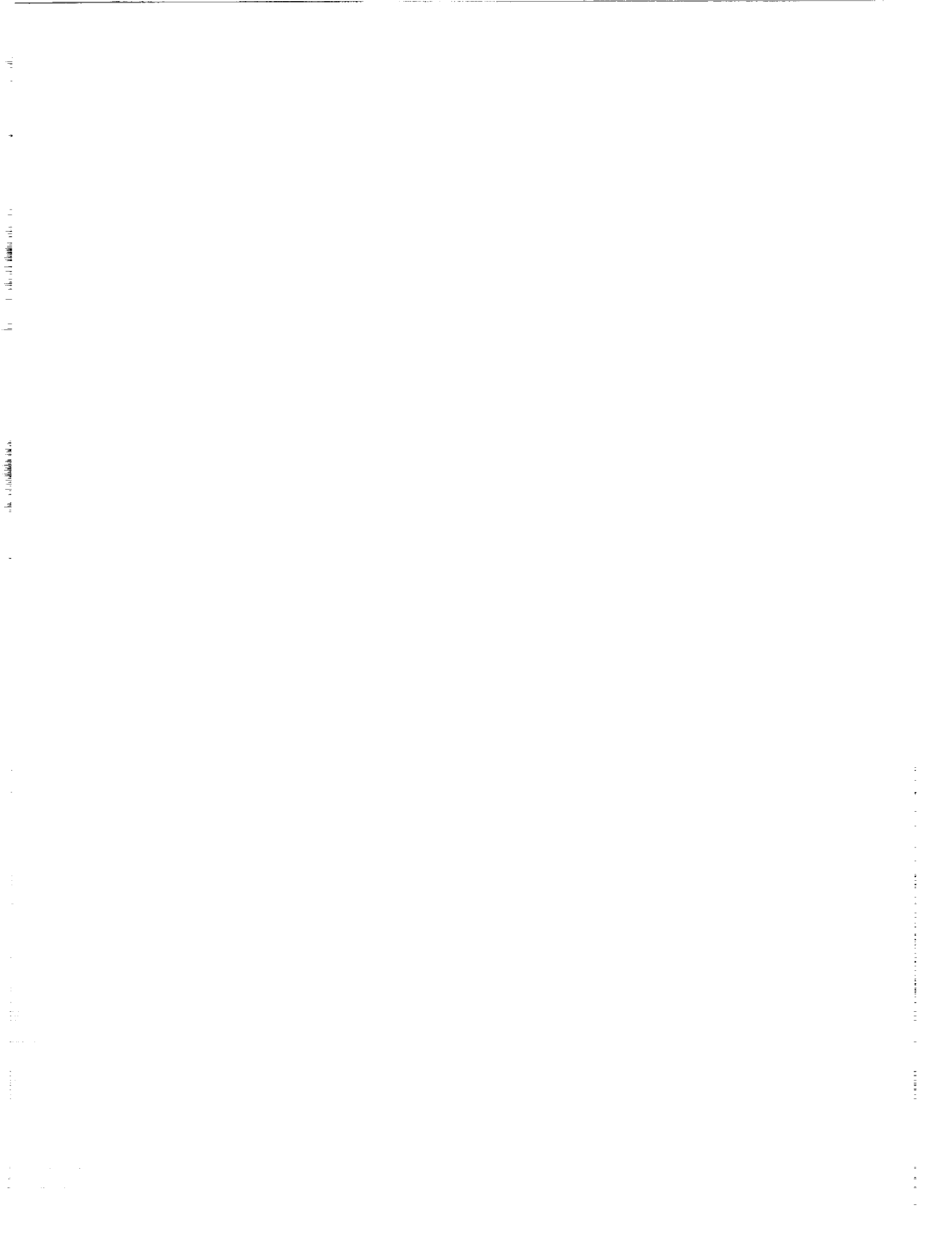

SECTION 1. GOVERNING BOARD REPORT

John Degnan, *National Aeronautics and Space Administration*

1.1 OVERVIEW OF SLR DURING 1999

Through international partnerships, the global distribution of SLR stations is slowly improving, especially in the Southern Hemisphere. NASA, working in cooperation with CNES and the University of French Polynesia, has moved MOBLAS-8 to the island of Tahiti and established SLR operations there. In late spring of 2000, MOBLAS-6 will move to Hartebeesthoek in South Africa (which already has VLBI, GPS, and DORIS facilities) to create the first Fundamental Station on the African continent. NASA and the South African Foundation for Research Development (FRD) will jointly sponsor operations in Hartebeesthoek. Recently, the Australian Survey and Land Information Group (AUSLIG), in partnership with NASA, took over the operations of the Yarragadee SLR system MOBLAS-5. Negotiations between NASA and the University of La Plata are ongoing to establish a new co-sponsored site in Argentina using the TLRs-4 system. An SLR system for a Chinese-Argentinean SLR station at the San Juan Observatory in western Argentina is being prepared by the Beijing Astronomical Observatory. The BKG in Germany has announced that another South American site in Concepcion, Chile, has been selected for their multi-technique Totally Integrated Geodetic Observatory (TIGO). This installation, scheduled for Spring 2001, will be the first Fundamental Station in South America following the termination of SLR and VLBI operations in Santiago, Chile. Thus, within a period of only one year, the number of SLR stations in South America may grow from one (Arequipa, Peru) to four. Operations at the new Australian station on Mt. Stromlo, which replaced the older Orroral site near Canberra, are going extremely well in terms of both data quantity and quality. Thus, we anticipate as many as eight SLR stations operating in the Southern Hemisphere by late 2001 compared to four today.

The Peoples' Republic of China has made a substantial investment in SLR stations and technology over the past two years. The SLR station in Kunming was recently re-established, bringing the total number of Chinese permanent sites to five (Shanghai, Changchun, Wuhan, Beijing, and Kunming). Under the technical leadership of Dr. Yang FuMin and with international cooperation, the data quality and quantity from the Chinese stations continue to improve, most notably at Changchun. In addition, the Wuhan SLR station has been recently moved to a site outside the city where there is significantly better atmospheric seeing, and construction is nearing completion on two mobile Chinese SLR stations which will occupy additional sites within China to support regional measurement programs. A modern Russian SLR station near Moscow started operation in 1999, and permission is being requested from the Russian government to integrate it into SLR operations. A second new Russian SLR station is under construction in the Altay region (see the Russian Network report, Section 4.3.1).

Elsewhere in Asia, the news is not so good. The Communications Research Laboratory (CRL) in Tokyo appears to be in the process of shutting down routine operations at its four Keystone sites by September 2000. Fortunately, the Simosato site, operated by the Japanese Hydrographic Institute, will continue to provide data in this important region.

The number of spacecraft tracked by SLR continues to grow at an accelerating rate. Within the next two year period, between 10 and 12 missions are likely to request SLR support (see Section 3.1). Interest in SLR has clearly been heightened by several recent failures of microwave navigation devices.

New applications of SLR data came to light during 1999. It was recently learned that all of the current constellation of approximately 20 SLR satellites are routinely tracked by ground-based radars assigned to keep track of space debris. The precise SLR orbital ephemerides are used operationally as “ground truth” to calibrate the ground radars, resulting in greatly improved trajectories for thousands of pieces of space debris, which could endanger the Space Shuttle, the International Space Station, as well as unmanned spacecraft. The SLR-calibrated data, with its tighter error bars, has helped to dramatically reduce the number of collision-avoidance maneuvers required by manned and unmanned spacecraft.

The year 1999 also marks the first full operating year for the new International Laser Ranging Service (ILRS). From my perspective as the first Governing Board Chairman, the establishment of the ILRS appears to have re-energized the satellite and lunar laser ranging communities with a heightened spirit of international cooperation and has provided a true focal point for a user community seeking SLR services.

1.2 ORIGIN AND ESTABLISHMENT OF THE ILRS

For many years, international SLR activities had been organized under the Satellite and Lunar Laser Ranging (SLR/LLR) Subcommittee of the CSTG. The Subcommittee provided a venue for organizing tracking campaigns, adopting data formats, reporting on network status, and sharing technology. However, membership and commitment to the Subcommittee were informal, and the main focus was on systems and data acquisition rather than on the production of consistent and high quality data products for end users.

With strong encouragement from Gerhard Beutler, then President of the CSTG, the CSTG SLR/LLR Subcommittee Steering Committee undertook the formation of the ILRS. A draft Terms of Reference, detailing the mission and the organization of the new service was written and accepted by the CSTG Executive Board in May 1997. A joint CSTG/IERS Call for Participation in the new ILRS was drafted by the SLR/LLR Subcommittee Chairman, John Degnan, and the SLR Representative on the IERS Directing Board, Bob Schutz, and issued on 24 January 1998. Institution proposals in response to the Call were evaluated at a special meeting of the CSTG SLR/LLR Subcommittee Steering Committee and subsequently approved by both the CSTG Executive Board and the IERS Directing Board on 18 April 1998. ILRS approval was granted to 46 tracking stations, 4 Operations Centers, 3 Analysis Centers, 4 Lunar Analysis Centers, 18 Associate Analysis Centers, 2 Global Data Centers and 1 Regional Data Center. The Central Bureau was established at the NASA Goddard Space Flight Center with John Bosworth as Director and Michael Pearlman of the Harvard-Smithsonian Center for Astrophysics as Secretary.

Appointments and elections of Governing Board members were carried out during the summer of 1998. On 22 September 1998, the CSTG SLR/LLR Subcommittee was officially disbanded, and replaced by the First ILRS General Assembly, held in conjunction with the 11th International Workshop on Laser Ranging in Deggendorf, Germany. The first ILRS Governing Board meeting was held on 25 September 1998; John Degnan was elected by the Board as Chairperson, and the Coordinators and Deputy Coordinators for the various Working Groups were also selected.

In July 1999, the Directing Board of the International Association of Geodesy (IAG), meeting at the IUGG Conference in Birmingham, UK, established the ILRS as an official Service of the IAG, on an equal par with the other three IAG Services - the International Earth Rotation Service (IERS), the International GPS Service (IGS), and the newly established International VLBI Service (IVS).

1.3 ORGANIZATION OF THE ILRS

The ILRS accomplishes its mission through the following permanent components:

- Tracking Stations and Subnetworks
- Operations Centers
- Global and Regional Data Centers
- Analysis, Lunar Analysis, and Associate Analysis Centers
- Central Bureau (Director, J. M. Bosworth; Secretary, M. Pearlman)
- Governing Board and Working Groups (Chairperson, J. J. Degnan)

Tracking Stations range to a constellation of approved satellites (including the Moon), contained in a list of satellites compiled and approved by the ILRS Governing Board, through the use of state of the art laser tracking equipment and data transmission facilities which allow for a rapid (at least daily) data transmission to one or more Operations and/or Data Centers (see below). Tracking Stations may be organized into regional or institutional **subnetworks**.

Operational Centers are in direct contact with tracking sites organized in a subnetwork. Their tasks include the collection and merging of data from the subnetwork, initial data quality checks, data reformatting into a uniform format, compression of data files if requested, maintenance of a local archive of the tracking data, and the electronic transmission of data to a designated ILRS Data Center. Operational Centers also provide the tracking sites with sustaining engineering, communications links, and other technical support. In addition, Operational Centers can perform limited services for the entire network. Individual tracking stations can also perform part or all of the tasks of an Operational Center themselves.

Global Data Centers are the primary interfaces to the Analysis Centers and the outside user community. Their primary tasks include the following:

- Receive/retrieve, archive and provide on-line access to tracking data received from the Operational/Regional Data Centers
- Provide on-line access to ancillary information such as site information, occupation histories, meteorological data, site specific engineering data, etc.
- Receive/retrieve, archive and provide on-line access to ILRS scientific data products received from the Analysis Centers
- Backup and secure ILRS data and products

Regional Data Centers reduce traffic on electronic networks. They collect reformatted tracking data from Operational Data Centers and/or individual tracking stations, maintain a local archive of the data received and, in some cases, transmit these data to the Global Data Centers. Regional Data Centers may also meet the requirements for Operational Centers and Global Data Centers (as defined in the previous and following paragraphs) of strictly regional network operations and

duplicate activities of Global Data Centers to facilitate easy access to the information and products.

Analysis Centers receive and process tracking data from one or more data centers for the purpose of generating ILRS products. The Analysis Centers are committed to produce the products, without interruption, at an interval and with a time lag specified by the Governing Board to meet ILRS requirements. The products are delivered to the Global Data Centers, to the IERS (as per bilateral agreements), and to other bodies, using designated standards. At a minimum, Analysis Centers must process the global LAGEOS-1 and LAGEOS-2 data sets and are encouraged to include other geodetic satellites in their solutions. The Analysis Centers provide, as a minimum, Earth orientation parameters on a weekly or sub-weekly basis, as well as other products, such as station coordinates, on a monthly or quarterly basis or as otherwise required by the IERS. Analysis Centers also provide a second level of quality assurance on the global data set by monitoring individual station range and time biases via the fitted orbits (primarily the LAGEOS 1 and 2 satellites) used in generating the quick-look analysis results.

Associate Analysis Centers are organizations that produce special products, such as satellite predictions, time bias information, precise orbits for special-purpose satellites, station coordinates and velocities within a certain geographic region, or scientific data products of a mission-specific nature. Associate Analysis Centers are encouraged to perform additional quality control functions through the direct comparison on individual Analysis Center products and/or the creation of "combined" solutions, perhaps in combination with data from other space geodetic techniques (e.g. VLBI, GPS, GLONASS, DORIS, PRARE, etc.), in support of the IERS International Terrestrial Reference Frame (ITRF) or precise orbit determination. Organizations with the desire of eventually becoming Analysis Centers may also be designated as Associate Analysis Centers by the Governing Board until they are ready for full scale operation.

Lunar Analysis Centers process normal point data from the Lunar Laser Ranging (LLR) stations and generate a variety of scientific products including precise lunar ephemerides, librations, and orientation parameters which provide insights into the composition and internal makeup of the Moon, its interaction with the Earth, tests of General Relativity, and Solar System ties to the International Celestial Reference Frame.

The **Central Bureau (CB)** is responsible for the daily coordination and management of the ILRS in a manner consistent with the directives and policies established by the Governing Board. The primary functions of the CB are to facilitate communications and information transfer within the ILRS and between the ILRS and the external scientific community, coordinate ILRS activities, maintain a list of satellites approved for tracking support and their priorities, promote compliance to ILRS network standards, monitor network operations and quality assurance of data, maintain ILRS documentation and databases, produce reports as required, and organize meetings and workshops.

The **Governing Board (GB)** consists of 16 members - 3 are ex-officio, 7 are appointed (2 from each major network - NASA, EUROLAS, and WPLTN - and one IERS appointee), and 6 members are elected by their peer groups (2 Analysis, 1 Data Center, 1 Lunar, and 2 At-Large Representatives). All GB members serve on at least one of four Standing **Working Groups (WG)**, led by a Coordinator and Deputy Coordinator. The four Standing Working Groups are: **(1) Missions, (2) Networks and Engineering, (3) Analysis, and (4) Data Formats and Procedures**. The GB may also create Temporary or Ad-Hoc Working Groups when the need

arises. In 1999, an **Ad-Hoc Signal Processing Working Group** was assembled, under the leadership of Graham Appleby, to provide improved satellite range correction models to the analysts. Table 1.4-1 lists the current GB membership, their nationality, and special function (if any) on the Governing Board.

Name	Position	Place of Residence
Bob Schutz	Appointed, IERS Representative to ILRS	USA
David Carter	Appointed, NASA	USA
Francois Barlier	Elected, At-Large, Missions WG Deputy Coordinator	France
Hermann Drewes	Ex-Officio, CSTG President	Germany
Hiroo Kunimori	Appointed, WPLTN, Missions WG Coordinator	Japan
John Bosworth	Ex-Officio, Director ILRS Central Bureau	USA
John Degnan	Appointed, NASA, Governing Board Chairperson	USA
John Luck	Elected, At-Large, Data Formats & Procedures WG Coordinator	Australia
Michael Pearlman	Ex-Officio, Secretary, ILRS Central Bureau	USA
Peter Shelus	Elected, Lunar Rep., Analysis WG Deputy Coordinator	USA
Richard Eanes	Elected, Analysis Rep.	USA
Ron Noomen	Elected, Analysis Rep., Analysis WG Coordinator	Netherlands
Werner Gurtner	Appointed, EUROLAS, Networks & Eng. WG Coordinator	Switzerland
Wolfgang Schlueter	Appointed, EUROLAS, Networks & Eng. WG Deputy Coord.	Germany
Wolfgang Seemueller	Elected, Data Centers Rep., Data Formats & Procedures WG Deputy Coordinator	Germany
Yang FuMin	Appointed, WPLTN	PRC

Table 1.3-1: Current ILRS Governing Board

1.4 INTERFACE WITH OTHER ORGANIZATIONS

Although the ILRS is no longer a sub-Commission of the CSTG, the ILRS continues to maintain close ties with its former parent organization. Hermann Drewes has recently replaced Gerhard Beutler as CSTG President following Gerhard's elevation to IAG Vice-President. The chairpersons of the three IAG space geodetic services - IGS, ILRS, and IVS - all serve on the CSTG Executive Board. This enhances the coordination and cooperation between the various space geodetic communities.

During the past year, the IGS solicited and received support from the ILRS in two IGEX campaigns designed to evaluate the quality of GLONASS orbits as determined by microwave and optical techniques. As many as nine GLONASS satellites (3 in each of 3 planes) were tracked during the first campaign; by mutual agreement, this was later reduced to 3 satellites during the extended campaign which continues today. Similarly, in January 2000, a Joint IVS/IGS/ILRS Working Group was formed, under the leadership of the IVS, to study anomalies in GPS orbits using a combination of GPS, VLBI, and SLR tracking. Richard Biancale and Graham Appleby were recommended by the ILRS Analysis WG to serve as ILRS representatives to the Joint Working Group and approved by the full Board.

The ILRS also maintains close ties with the International Earth Rotation Service (IERS), which is a prime user of laser ranging data in maintaining the Terrestrial Reference Frame. The Analysis Coordinator (Ron Noomen) on the ILRS Governing Board is a voting member of the IERS Directing Board, and an SLR Representative (Bob Schutz) is appointed by the IERS to serve as a voting member of the ILRS Governing Board. The Lunar Representative (Peter Shelus), who also serves as the Deputy Coordinator of the Analysis WG, is an invited attendee at IERS Directing Board meetings and can vote in the Analysis Coordinator's absence.

A diagram showing the internal structure of the ILRS and its interfaces with key organizations is shown in Table 1.3-1.

1.5 CURRENT STATUS AND FUTURE PROSPECTS

The first operating year of the International Laser Ranging Service (ILRS) has been an active one. While all of the ILRS institutions have worked hard to meet the demanding new requirements, we would like to highlight two areas that we believe will have a major impact on SLR operations, i.e. the Working Groups and the Central Bureau. These groups have submitted more detailed individual reports elsewhere in this volume so only brief will be given.

WORKING GROUPS

Working Groups (WG's) were originally created to serve as the primary foci for Governing Board activities. Coordinators and Deputy Coordinators for the four Standing Working Groups were chosen from among the Governing Board members at their first meeting in Deggendorf. At our Second General Assembly in den Haag, Netherlands, our first Ad-Hoc (temporary) Working Group on Signal Processing was created and placed under the direction of Graham Appleby. We are very pleased to report that all of these WG's have attracted talented people from the general ILRS membership who have contributed greatly to the success of these efforts.

- **Missions (Coordinator: Hiroo Kunimori, Japan)**
 - This group has formalized and standardized the required mission documentation needed to obtain ILRS approval for new missions and campaigns.
 - These new procedures have been applied to several ongoing campaigns and upcoming missions such as CHAMP.
 - The group continues to work with new missions and campaign sponsors to develop and finalize tracking plans and to establish recommended tracking priorities.
- **Data Formats and Procedures (Coordinator: John Luck, Australia)**
 - This very active group has been tightening up existing formats and procedures, rectifying anomalies, providing standardized documentation via the Web site, and setting up study subgroups and teams to deal with more complicated issues.
 - This group also recommended the establishment of the Ad-Hoc Signal Analysis WG.
- **Networks and Engineering (Coordinator: Werner Gurtner, Switzerland)**
 - This group has developed a new ILRS Site and System Information Form which is being distributed to the stations in an effort to update the engineering database.
 - The group has provided a new online link analysis capability for computing mean signal strengths expected from individual stations on different satellites.

- The group continues to add to the CB technology database and, with the help of Ulrich Schreiber (Germany), organized a successful ILRS Calibration Workshop in Florence last September.
- **Analysis (Coordinator: Ron Noomen, The Netherlands)**
 - This group has been working with 13 different ILRS analysis centers to achieve a unified set of analysis products presented in the internationally accepted SINEX format. Three associated pilot programs are underway.
 - To plan and implement these programs, the Analysis WG conducted a 3 day workshop in Frankfurt, Germany, in January 2000 and will conduct another in Delft, The Netherlands, in May. They also recommended the ILRS representatives to the Joint IVS/IGS/ILRS Working Group on GPS Anomalies.
- **Signal Processing (Coordinator: Graham Appleby, United Kingdom)**
 - This Ad-Hoc group is computing Center-of-Mass distributions for a number of satellites and developing recommendations for computing satellite corrections for different ranging hardware configurations.

CENTRAL BUREAU

The Central Bureau (CB) has also been extremely active. In addition to providing effective communications to, and coordinating the various activities of, the various elements of the ILRS, the CB has been actively providing new conveniences (such as targeted email exploders) and adding to the technical and scientific database. The information available via the ILRS Web Site has grown enormously during the past year, and many new links to related organizations and sites have been established. The site provides details and photographic material on the ILRS, the satellites and campaigns we support, individual SLR station characteristics, a scientific and technical bibliography on SLR and its applications, current activities of the Governing Board Working Groups and Central Bureau, meeting minutes and reports (including annual reports), tracking plans, etc. A new ILRS Reference Card was recently distributed to all ILRS Associates and Correspondents of record to provide easy online access to much of this material and to targeted email exploders. In coming months and years, we expect much more technical material and reports to be made available online with an enhanced search capability to quickly isolate more specific material of interest.

FIFTH ILRS GENERAL ASSEMBLY IN MATERA

The Fifth ILRS General Assembly will be held in conjunction with the 12th International Workshop on Laser Ranging to be held in Matera, Italy, during the week of November 13-17, 2000. The 12th SLR Workshop is sponsored by the Centro Geodesia Spaziale of the Agenzia Spaziale Italiana. The Program Chair, Dr. Giuseppe Bianco, will proudly treat attendees to a tour of the new lunar-capable Matera Laser Ranging Observatory (MLRO) and its state-of-the-art equipment. The precise date, time, and location of the General Assembly and the program agenda will be posted on the ILRS Web Site and distributed to all ILRS Associates and Correspondents via SLRmail when the information becomes available.

A new Governing Board will be installed at the Matera workshop. Elections will be held during the Summer of 2000 via E-mail as in the past election. At-Large members will again be elected last. Prior to the elections, the subnetworks and the IERS will be given the opportunity to reconfirm their current representatives or appoint new ones.

Prior General Assemblies were held in:

- Deggendorf, Germany, September 1998 (11th Workshop on Laser Ranging)
- Den Haag, Netherlands, April 1999 (EGS Symposium)
- Florence, Italy, September 1999 (Europto Laser Radar Conference)

Reports on ILRS meetings are routinely available online at the ILRS Web Site.

SECTION 2

CENTRAL BUREAU REPORT



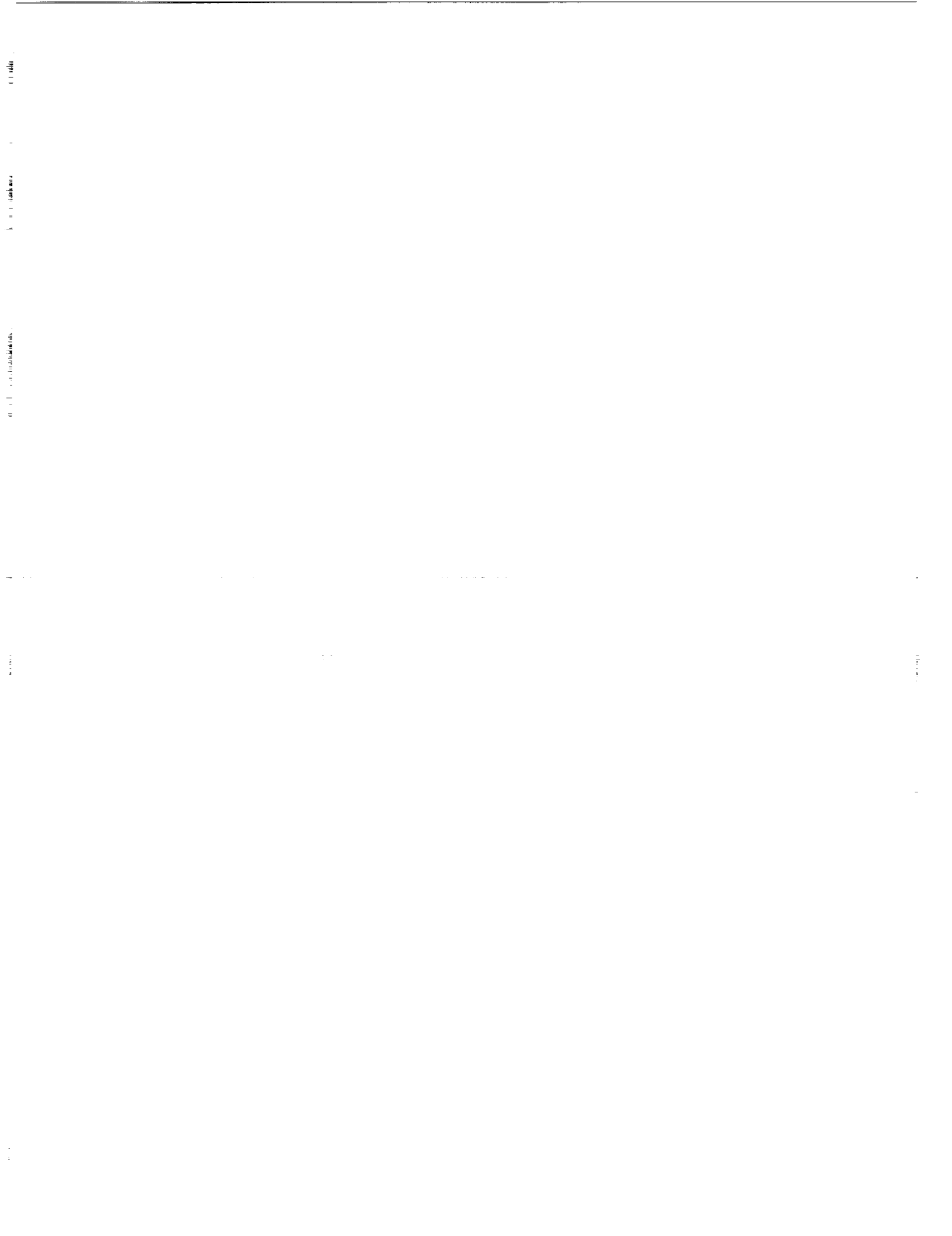

SECTION 2 - CENTRAL BUREAU REPORT

The Central Bureau (CB) is responsible for the daily coordination and management of ILRS activities. It facilitates communications and information transfer and promotes compliance with ILRS network standards. The CB monitors network operations and quality assurance of the data, maintains ILRS documentation, provides scientific and technological databases, and organizes meetings and workshops. In order to strengthen the ILRS interface with the scientific community, a Science Coordinator and Analysis Specialists within the CB take a proactive role to enhance dialogue, to promote Satellite Laser Ranging and Lunar Laser Ranging goals and capabilities, and to educate and advise the ILRS entities on current and future science requirements related to these measurement techniques. The Science Coordinator leads efforts to ensure that ILRS data products meet the needs of the scientific community and there is easy online access to all published material (via Abstracts) relevant to SLR science and technology.

2.1 STATUS AND ACTIVITIES OF THE CENTRAL BUREAU

Michael Pearlman, *Harvard-Smithsonian Center for Astrophysics*

John Bosworth, *National Aeronautics and Space Administration*

ORGANIZATION OF THE CENTRAL BUREAU

In response to the ILRS Call for Participation issued in January 1998, NASA submitted a proposal to operate the ILRS Central Bureau from GSFC. The proposal was accepted and the Central Bureau was organized in May 1998, shortly after the ILRS was endorsed by the IERS and the CSTG.

By drawing on available expertise from members of the GSFC SLR team and the Network coordinators, the Central Bureau provides the mix of talents necessary to support the technical and administrative services necessary for the ILRS. The Central Bureau staff includes the part-time services of people from NASA GSFC, the Harvard-Smithsonian Center for Astrophysics, Raytheon Information Technology and Scientific Services (RITSS), Honeywell Technology Solutions, Inc. (HTSI), and representatives from the three regional networks:

Name	Title	Institution
John Bosworth	Director	NASA GSFC
Michael Pearlman	Secretary	CfA
Steve Klosko	Science Coordinator	Raytheon ITSS
Van Husson	SLR Systems Specialist	Honeywell Technical Solutions, Inc.
Peter Dunn	Analysis Specialist	Raytheon ITSS
Mark Torrence	Analysis Specialist	Raytheon ITSS
Scott Wetzel	Operations Specialist	Honeywell Technical Solutions, Inc.
Carey Noll	Web Master	NASA GSFC
Erricos Pavlis	Analysis Specialist	NASA GSFC
Georg Kirchner	EUROLAS Net. Coordinator	Austrian Academy of Sciences
Hiroo Kunimori	WPLTN Net. Coordinator	CRL
David Carter	NASA Net. Coordinator	NASA GSFC

ACTIVITIES

Although the ILRS was not formally established until November 1998, the Central Bureau provided much of the early administrative, communications and coordination support during the ILRS organization and formulation stages. The Central Bureau supported the election process for Governing Board members, the selection of the ILRS logo, and the development of work plans for the Working Groups.

As one of its first tasks, the Central Bureau established the ILRS web site as a resource for information, communication and planning at:

http://ilrs.gsfc.nasa.gov/ilrs_home.html

The site provides current information on the ILRS organization, personnel, operations, missions planning, technology, data product and data product availability (see below). A communications center has been established at HTSI with parallel distribution to GSFC, CfA, and Raytheon ITSS with an established hierarchy for responses. Messages incoming to the Central Board are directed to cb@ilrs.gsfc.nasa.gov.

Outgoing mail to the general ILRS membership is routed through SLRMail at the EUROLAS Data Center (EDC). Specialized mail exploders have been provided through the CDDIS for intra-group communications to the Central Board, stations, analysis centers, data centers and the working groups.

From its beginning, the Central Bureau worked with the other emerging ILRS entities and their members to identify the key services and procedures that were deemed necessary to make the organization a success. Many were formulated as joint action items between one or more Working Groups and the Central Bureau. Some of the key items that have been accomplished so far include the establishment of:

- the ILRS web site;
- station performance standards;
- station performance and compliance reporting;
- report and documentation lists and libraries;
- documented data flow and prediction procedures; and
- formalized process for establishing tracking priorities, requesting mission support, and organizing campaigns.

Others still in process include the implementation of:

- a standardized site description data base;
- a weekly on-line assessment of station operations status;
- “intelligent” on-line forms for data base entries and updates;
- improved pointing predictions for “very” low earth orbiting satellites; and
- subdaily data submissions to the Data Centers.

Since the inception of the Central Bureau, its members with support from their home organizations have addressed these issues. A core group from the Central Bureau meets monthly to monitor progress on its actions items, to assess its interactions with the field stations and the other operational entities, and to monitor progress on Working Groups action items.



Figure 2.1-1 Central Bureau Core Group. In order: Mark Torrence, Scott Wetzel, Mike Pearlman, Van Husson, Peter Dunn, Julie Horvath, John Bosworth, Carey Noll. Not shown: Erricos Pavlis.

MEETINGS

The Central Bureau helped arrange the organizational meeting in Nice, France in April 1998 and organized the ILRS General Assembly Meetings in Deggendorf, Germany in September 1998, The Hague, the Netherlands in April 1999 and Florence, Italy in September 1999 and prepared the meeting reports for general distribution. Presentations on the ILRS have been presented at the Gemstone Meeting in Tokyo, Japan in January 1999, the IUGG Meeting in Birmingham, UK in July 1999 and the International Symposium on GPS in Tsukuba, Japan in October 1999.

CURRENT CHALLENGES

Although much has been accomplished through the end of 1999, current challenges over the next year for the Central Bureau include:

- strengthening the science liaison activity;
- encouraging and helping tracking stations and analysis centers to meet their minimum performance criteria;
- continuing the development of the ILRS website and data bases, in the areas of technology, science and applications, and operations, and formalize the process by which updates are approved;
- continuing the process of documenting configuration and standardizing processes/procedures.

2.2 MISSION PRIORITIES

Michael Pearlman, *Harvard-Smithsonian Center for Astrophysics*

The ILRS designates satellite priorities in an attempt to maximize data yield on the full satellite complex while at the same time placing greatest stress on the most immediate data needs. Priorities provide guidelines for the network stations, but stations may occasionally deviate from the priorities to support regional activities and to expand tracking coverage in regions with multiple stations. Tracking priorities are set by the Governing Board, based on application to the Central Bureau and recommendation of the Missions Working Group. The ILRS satellite priorities as of December 31, 1999 are given in Table 2.2-1.

Priority	Satellite	Sponsor	Altitude (Km)	Inclination	Campaign Ends
1	ERS-1	ESA	800	98.5	31 December 2000
2	GFO-1	US Navy	790	108.0	31 March 2000
3	ERS-2	ESA	800	98.6	
4	TOPEX/Poseidon	NASA/CNES	1,350	66.0	
5	Sunsat	Stellenbosch Univ	400	93.0	17 March 2000
6	Starlette	CNES	815 - 1,100	49.8	
7	WESTPAC	WPLTN	835	98	
8	Stella	CNES	815	98.6	
9	Beacon-C	NASA	950 - 1,300	41	13 July 2000
10	Ajisai	NASDA	1,485	50	
11	LAGEOS-2	ASI/NASA	5,625	52.6	
12	LAGEOS-1	NASA	5,850	109.8	
13	GLONASS 80	RSA	19,100	65	
14	GLONASS 72	RSA	19,100	65	
15	GLONASS 79	RSA	19,100	65	
16	GPS 35	US Air Force	20,100	54.2	
17	GPS 36	US Air Force	20,100	55.0	
18	Etalon 1	RSA	19,100	65.3	
19	Etalon 2	RSA	19,100	65.2	
Priority	Lunar Targets	Sponsor			
1	Apollo 15	NASA			
2	Apollo 11	NASA			
3	Apollo 14	NASA			
4	Luna 21	RSA			

Table 2.2-1 ILRS Tracking Priorities as of 31 December 1999

Priorities typically decrease with increasing orbital altitude and orbital inclination (at a given altitude). Priorities may then be increased on some satellites to intensify support for (1) active missions (such as altimetry), (2) special campaigns (such as IGEX 98), (3) post-launch intensive tracking phases, and (4) missions of greatest importance to the scientific and analysis communities.

Tracking priorities are formally reviewed semiannually at the ILRS General Assembly Meetings. Updates are made as necessary at the discretion of the Governing Board.

2.3 NETWORK CAMPAIGNS

Scott Wetzel, *Honeywell Technology Solutions, Inc.*

Michael Pearlman, *Harvard-Smithsonian Center for Astrophysics*

INTRODUCTION

The ILRS is responsible for the tasking and coordinating of special SLR tracking campaigns that are requested by users, supported by the Missions Working Group, and approved by the ILRS Governing Board. Campaigns are typically scheduled for periods from a few months up to a year and may be renewed if warranted. Campaigns are requested to support:

1. satellites in orbit that are having technical problems with onboard systems;
2. new experiments using satellites whose main mission has already been completed; and
3. special combinations of satellites for synergistic experiments.

A user can request a tracking campaign through the ILRS Central Bureau by first completing an on-line SLR Mission Support Request Form accessible through the ILRS web site at:

<http://ilrs.gsfc.nasa.gov/ilrssup.html>

The form provides the ILRS with a description of the mission objectives; mission requirements; responsible individuals, organizations, and contact information; timeline; satellite subsystems; and details of the retroreflector array and its placement on the satellite. Once the Central Bureau receives the completed form, the form is submitted to the Missions Working Group for review, iteration with the user, if necessary, and development of a recommendation on ILRS support. This recommendation takes into consideration the realism of the program, interest of others in the results, and the overall tracking load on the ILRS network. During the campaign, the Central Bureau will assign the campaign satellites a position within the ILRS tracking priority schedule.

Campaign reports with network tracking statistics and operational comments are issued weekly by the Central Bureau through SLR Mail. The Central Bureau monitors campaign progress to determine if adequate support is being provided. Campaign sponsors (users) are requested to report at the ILRS General Assembly Meetings on the status of ongoing campaigns, including the responsiveness of the ILRS to their needs and on progress toward results. They are also expected to report at the meetings on their results and experience from completed campaigns.

The following sections describe both the campaigns that occurred and have been concluded in the past year and current campaigns supported by the ILRS. Additional information can be found on the ILRS web site under the Missions and Campaigns section.

CAMPAIGNS COMPLETED IN 1999

Three campaigns were completed in 1999 (see Table 2.3-1).

Campaign	Initiated by	Start Date	End Date	Purpose	No. Passes
Geos-3	NASA - Frank Lemoine	Oct. 15, 1998	Apr. 20, 1999	Gravity Field Modeling	2241
IGEX 98	IGEX - Werner Gurtner	Oct. 19, 1998	Apr. 19, 1999*	GLONASS Complex Evaluation	9012 seg.
Etalon	WPLTN - Hiroo Kunimori	Oct. 30, 1999	Nov. 30, 1999	Geodetic Modeling in the WPLTN Region	297 seg.

* Note: The Official IGEX campaign on eleven GLONASS Satellites was completed on April 19, 1999 but ILRS continues to track three GLONASS satellites on a routine basis.

Table 2.3-1 ILRS Campaigns Completed in 1999

GEOS-3

Launched in 1975, the Geodetic Earth Orbiting Satellite 3 (GEOS-3) was the first operational radar altimeter to measure the topography of the ocean surface. It also hosted an array of tracking systems for intercomparison of techniques. GEOS-3, at 115 degrees inclination, is in a fairly unique orbit. Its SLR contribution to the present gravity field models was based on ranging data of decimeter quality taken in the latter part of the 1970's and early 1980's. The present availability of sub-cm quality SLR data promised considerable improvement in orbit sensitive terms in the gravity field model. Originally requested for three months, the tracking campaign was extended for an additional three months to enrich the data set.

More information can be found on the ILRS web site at

<http://ilrs.gsfc.nasa.gov/geos.html>

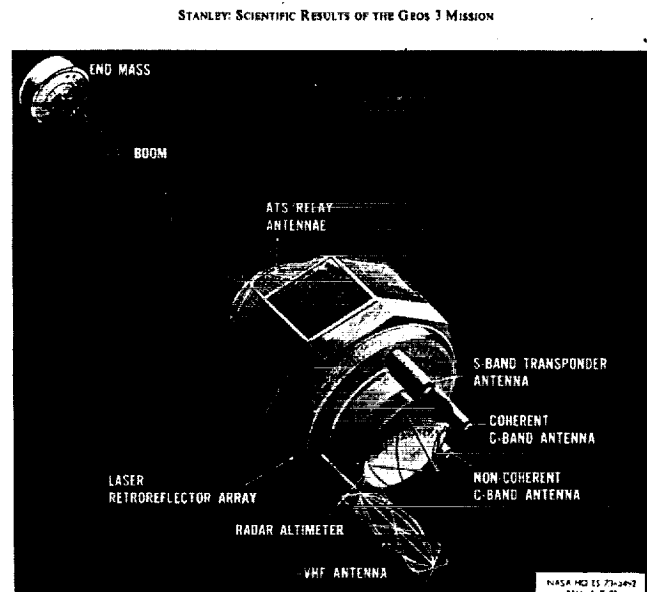

Fig. 1. Artist concept of Geos 3 spacecraft.

Figure 2.3-1 Artist's conception of GEOS-3

IGEX98

The International GLONASS EXperiment 1998 (IGEX 98) Campaign was organized by the IAG Commission VIII, the CSTG, IGS, and ION to provide independent SLR orbits to:

- evaluate the GLONASS-receivers as geodetic and navigation tools;
- help develop GLONASS radiation pressure models; and
- test combined SLR/microwave processing techniques.

The long-term goals of the campaign are to:

- establish the role of SLR for calibrating GPS and GLONASS;
- separate “gravitational and non-gravitational effects” in the trajectory of high orbiting satellites (using GLONASS, GPS, and Etalon data),
- stabilize the effect of SLR observations on GPS/GLONASS microwave-derived length of day (and integrated LoD=UT) and possibly nutation estimates, and
- combine SLR/GPS/GLONASS analysis for these high-orbiting satellites to conduct the first Global GLONASS Observation Campaign for geodetic and geodynamics applications.

Eleven GLONASS satellites were tracked in support of the campaign, which lasted from October 19, 1998, through mid-January, 1999. The campaign was extended for an additional three months to support the newly launched GLONAS 80, 81, and 82. The network continues to support GLONAS 70, 72, and 79 on a continued routine basis.

More information can be found on the ILRS web site at

<http://ilrs.gsfc.nasa.gov/glonass.html>

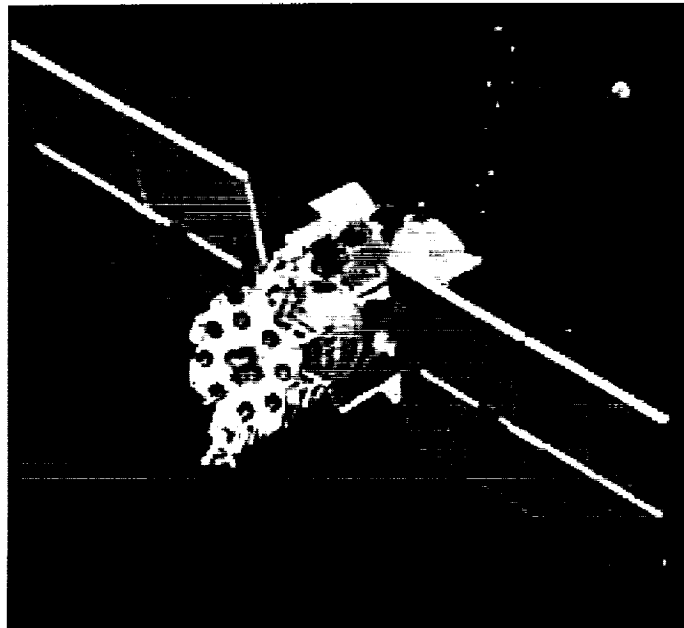

Figure 2.3-2 Artist's Conception of GLONASS

Etalon

The SLR passive geodetic satellites, Etalon-1 and 2, were launched by the Russian Federation to improve the accuracy of the terrestrial reference frame and to support measurements of Earth rotation parameters and the gravity field.

The one-month Etalon Campaign in November 1999, sponsored by the WPLTN, included intensive Etalon and Lages tracking to help develop a geophysical information system in the Asia Pacific region. The campaign also included GPS, DORIS, and VLBI measurements in the region.

More information can be found on the ILRS web site at

<http://ilrs.gsfc.nasa.gov/etalon.html>

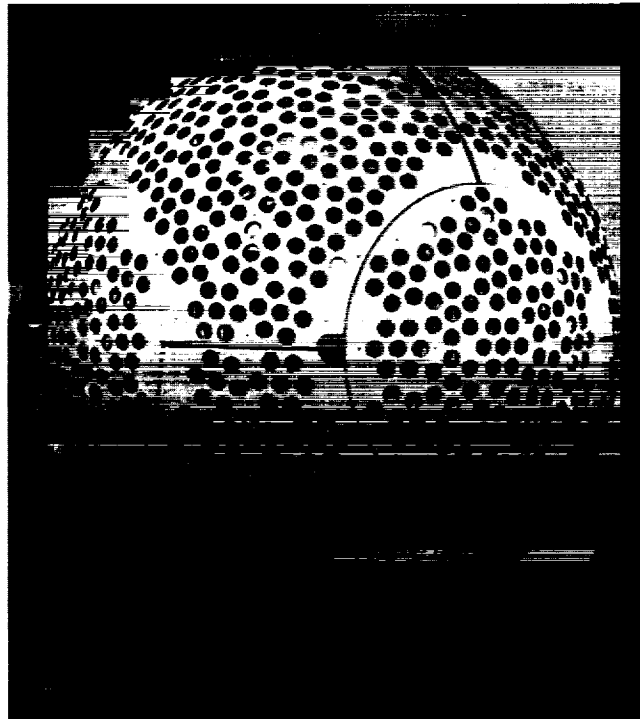

Figure 2.3-3 Etalon Satellite

ONGOING CAMPAIGNS

Four campaigns initiated prior to the year 2000 are still underway (Table 2.3-1 provides a brief summary).

Campaign	Initiated by	Start Date	Planned End Date	Purpose	No. Passes
BE-C	Univ. of Texas Minkang Cheng	July 15, 1999	October 31, 2000	Gravity field modeling	2557
ERS-1	D-PAF Franz-Heinrich Massman	July 20 1998	December 31, 2000	POD for ocean surface studies	5994
SUNSAT	NASA Erricos Pavlis	May 7, 1999	October 17, 2000	GPS/SLR intercomparison	1066
GFO-1	NASA Frank Lemoine	Apr. 22, 1998	October 31, 2000	POD for ocean surface studies	4461

Table 2.3-1 Ongoing ILRS Campaigns

Beacon Explorer-C

Beacon-C (BE-C) was launched in 1965 as part of the US National Geodetic Satellite Program

It was the second retroreflector equipped Earth satellite to be launched to support measurement technique intercomparason, determination of station positions, and modeling of the gravity field.

Tracking on BE-C was reactivated after many years at the request of the University of Texas to augment the current complex of satellites used to study the secular and long period tidal variations in the Earth's gravity field. These studies are providing a critical global constraint on our understanding of the rheology of Earth, including the mantle viscosity and elasticity, and post-glacial rebound. The requirement for both the long-term temporal and spatial distribution of the SLR tracking data (i.e., from the satellites at various inclinations and altitudes) is critical for separating the variations at different degrees and orders. Since all all of the current geodetic satellites are orbiting at inclinations ranging from 50 to 110 degrees, BE-C satellite is the only useful target with a relatively low inclination (41 degrees). With SLR tracking capability having improved dramatically since the intensive Beacon-C tracking of the 1960's and 70's, the campaign is making a very beneficial to the modeling activity.

A six month campaign was initiated in July 1999. An extension was authorized through October 2000, based on the success to date.

Additional information can be found on the ILRS web site at:

<http://ilrs.gsfc.nasa.gov/beaconC.html>

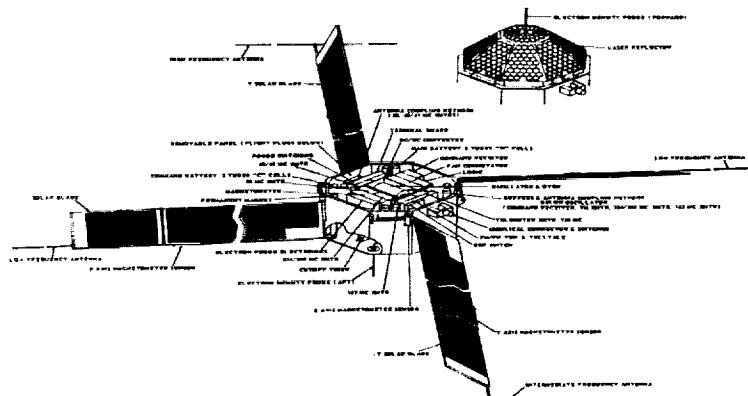

Figure 2.3-4 Beacon-C

ERS-1

European Remote Sensing satellite (ERS-1) is the first in a family of multi-disciplinary Earth Observation Satellites with a radar altimeter and a synthetic aperture radar (SAR) to study the topography of the ocean surface. Shortly after launch in 1992 the primary tracking system PRARE failed, and SLR became the only tracking technique to support the altimeter and the SAR. When ERS-2 was launched in 1997, its predecessor was placed in a dormant mode. In 1998 the European Space Agency reactivated ERS-1 so that the pair of satellites could work in a tandem SAR mode to map details of the ocean surface. SLR continues to support ERS-1 tracking in campaigns of 3 - 6 months at a time as the on-board systems continued to function for periods far beyond expectation. ERS-2 has been routinely tracked by the network since launch.

Additional information can be found on the ILRS web site at:

<http://ilrs.gsfc.nasa.gov/ers1.html>

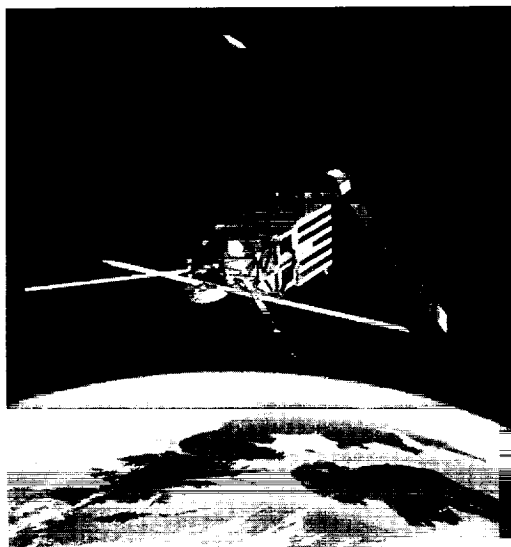

Figure 2.3-5a ERS-1 Satellite

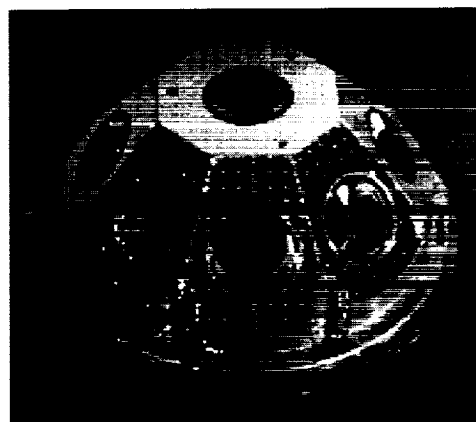

Figure 2.3-5b ERS-1 SLR Array

Sunsat

Stellenbosch UNiversity SATellite (SUNSAT) is a micro-satellite designed and built by electrical engineering students at the Stellenbosch University in South Africa. As an engineering project, the mission objectives are optical imaging of Earth surface conditions, email communications, studies of the Earth's magnetic field, gravity field, atmosphere and ionosphere, and evaluation of the on-board GPS system.

SLR is providing accurate orbits with which to evaluate the GPS. The GPS receiver is working and data is being evaluated at JPL. Several problems were encountered early in the mission which are now being overcome. The GPS L2 signal-to-noise ratio was very low due to shortcomings in the software. Spacecraft power limitations severely constrained GPS hours of operation. The S-band downlink failed, limiting data transmission to 9600 baud. The power limitation has been somewhat relieved by the orbital precession that has increased solar illumination. Software modifications are underway to alleviate the data congestion problem. Once the

software is in place, the project expects that GPS usage will increase to as much as 60 hours per month.

SLR tracking started in May 1999 and is scheduled to run through mid-March 2000. In all likelihood an extension will be requested.

Additional information can be found on the ILRS web site at:

<http://ilrs.gsfc.nasa.gov/sunsat.html>

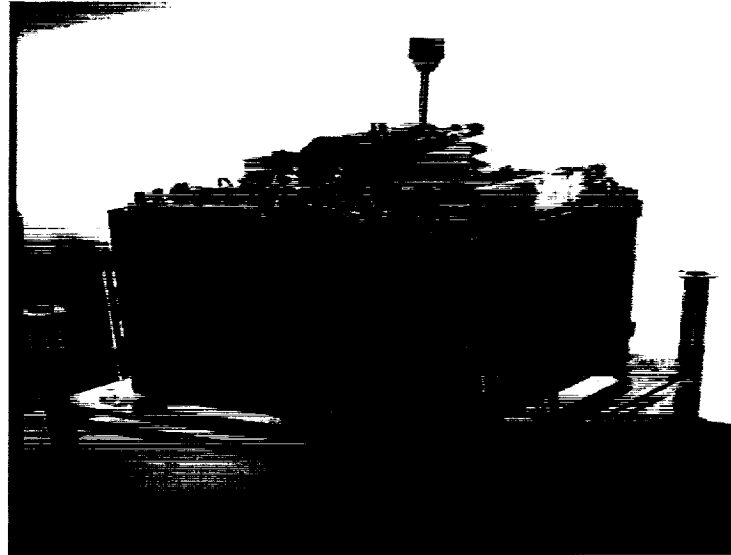

Figure 2.3-6 SUNSAT

GFO-1

The GEOSAT Follow-On 1 (GFO-1) program is the U.S. Navy's initiative to develop an operational family of radar altimeter satellites to maintain continuous ocean observation, including precise measurement of both mesoscale and basin-scale oceanography. The length and time scales of these processes are too large for conventional in-the-water oceanographic instrumentation configurations to measure. Satellite altimetry is the only known method by which oceanographers can precisely measure sea surface topography. The shape of the sea surface is the only physical variable directly measurable from space that is directly and simply connected to the large-scale movement of water and the total mass and volume of the ocean.

GFO-1 was launched on 10 February 1998 and ILRS tracking support commenced on 22 April 1998. The satellite had several problems including spontaneous resets that placed the spacecraft in stow mode and failure of the control system for the four GPS receivers. The reset and stow problem has been alleviated and routine SLR and Doppler tracking have provided the orbit determination for the altimeter. The initial six month tracking campaign has been extended through October 2000 to support the project in its efforts to overcome its difficulties. The altimeter is now going through calibration and validation. Once the altimeter performance is verified and operations can be sustained, the satellite will become a candidate for placement on the routine ILRS tracking roster.

Additional information can be found on the ILRS web site at:

<http://ilrs.gsfc.nasa.gov/gfo.html>



Figure 2.3-7a GFO-1 Satellite

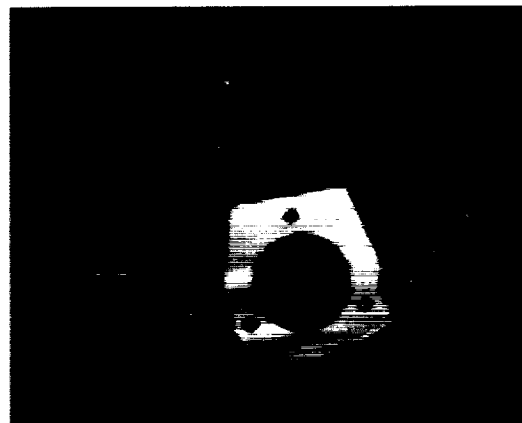

Figure 2.3-7b GFO-1 SLR Array

CONCLUSION

The campaign structure has been easy to implement and has allowed the ILRS to provide quick response to user needs. The ILRS has supported a number of campaigns over the past year. In particular, being able to bring back 20- and 30-year-old satellites has been very helpful to the scientific community.

2.4 UPCOMING MISSIONS

Scott Wetzel, *Honeywell Technology Solutions, Inc.*

Michael Pearlman, *Harvard-Smithsonian Center for Astrophysics*

INTRODUCTION

Request for tracking support for new missions must be submitted to the Central Bureau, reviewed by the Missions Working Group and approved by the Governing Board. New missions request tracking support by first completing an on-line SLR Missions Support Request Form accessible through the ILRS web site at:

<http://ilrs.gsfc.gov/ilrsup.html>

The form provides the ILRS with a description of the mission objectives; mission requirements; responsible individuals, organizations, and contact information; timeline; satellite subsystems; and details of the retroreflector array and its placement on the satellite. This form also outlines the early stages of intensive support that may be required during the initial orbital acquisition and stabilization and instrument checkout phases. Once the Central Bureau receives the completed form, the form is submitted to the Missions Working Group for review, iteration with the user, if necessary, and development of a recommendation on ILRS support including tracking priorities. This recommendation takes into consideration the realism of the program, interest of others in the results, and the overall tracking load on the ILRS network. The Central Bureau then submits the request to the Governing Board for approval.

Once tracking support is approved, the Central Bureau works with the new missions to develop a Mission Support Plan detailing the level of tracking, the schedule, the points of contact, and the channels of communication. New missions normally receive very high priority during the acquisition and checkout phases and are then placed at a routine priority based on the satellite category and orbital parameters.

After launch, New Mission Reports with network tracking statistics and operational comments are issued weekly by the Central Bureau through SLRreports. The Central Bureau monitors progress to determine if adequate support is being provided. New mission sponsors (users) are requested to report at the ILRS Plenary meetings on the status of ongoing campaigns, including the responsiveness of the ILRS to their needs and on progress toward results. They are also expected to report at the meetings on their results and experience from the tracking support.

NEW MISSIONS PLANNED FOR 2000 – 2001

Seven new missions are anticipated during 2000 – 2001 (See Table 2.4-1)

<i>Mission Name</i>	<i>Support Requester</i>	<i>Planned/Actual Launch Date</i>	<i>Mission Duration</i>	<i>Altitude (km)</i>	<i>Inclination (Deg)</i>	<i>Received Mission Request Form</i>	<i>Application</i>
CHAMP	GFZ Germany	July 2000	5 yrs	470	83	Yes	gravity and magnetic field mapping
JASON-1	CNES/NASA France/USA	Nov. 2000	5 yrs	1336	66	Yes	Environmental change
Vegetation Canopy Lidar (VCL)	NASA USA	April 2001	18 mos	390-410	65	Yes	Vegetation and land topography
Envisat-1	ESA Europe	Nov. 2001	5 yrs	800	98.5	No	Environmental change
IceSat (GLAS)	NASA USA	July 2001	3-5 yrs	600	94	No	ice level and ocean surface topography
Gravity Probe B (GP-B)	NASA-JPL USA	Sept. 2001	1-2 yrs	400	90	Yes	Relativity
ADEOS-II	NASDA Japan	Nov. 2001	3 yrs	803	98.6	No	Ocean circulation; atmosphere-ocean interaction

Table 2.4-1 New Missions Planned for 2000-2001

CHAMP

The CHALLENGING Mini-Satellite Payload (CHAMP) will measure long-term temporal variations in the magnetic field, the gravity field and the atmosphere. Satellite laser ranging data will be used for precise orbit determination in connection with GPS for gravity field recovery; calibration of the on-board microwave orbit determination system (GPS); and two-color ranging experiments. CHAMP will have the following instrumentation onboard:

1. dual-frequency GPS receiver,
2. three-axes accelerometer,
3. magnetometer instrument package,
4. digital ion drift meter, and
5. a retroreflector array.

The laser retroreflector consists of four prisms to reflect short laser pulses back to the transmitting ground station. This enables the measurement of the direct two-way range between ground station and satellite with an accuracy of 1 to 2 cm.

More details on the CHAMP Mission are available at:

<http://ilrs.gsfc.nasa.gov/champ.html>



Figure 2.4-1a Champ satellite

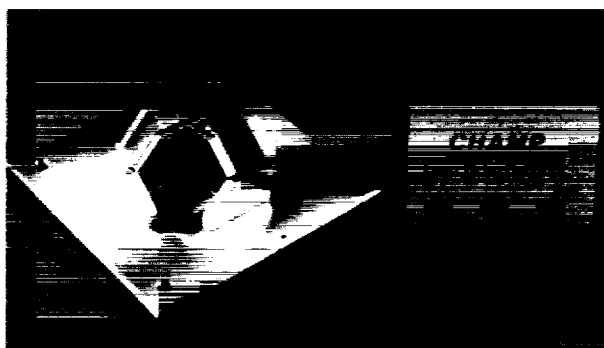

Figure 2.4-1b CHAMP SLR Array

Jason-1

Jason-1 is an oceanography mission to monitor global ocean circulation, discover the tie between the oceans and atmosphere, improve global climate predictions, and monitor events such as El Niño conditions and ocean eddies. The Jason-1 satellite, a joint France/USA mission, is a follow-on to the highly successful Topex/Poseidon altimeter mission. Precision orbit determination will be provided by GPS and SLR. Jason-1 will have the following instrumentation onboard:

1. Microwave radiometer
2. DORIS dual frequency system receiver
3. Dual-frequency solid-state altimeter
4. GPS receiver
5. Retroreflector array

The corner cubes are symmetrically mounted on a hemispherical surface with one nadir-looking corner cube in the center, surrounded by an angled ring of eight corner cubes. This will allow laser ranging in the field of view angles of 360 degrees in azimuth and 60 degrees elevation around the perpendicular to the satellite's -Zs earth panel. The design is identical to the array to be used on ADEOS-2 and GFO-1.

Additional information on the Jason-1 Mission can be found at

<http://ilrs.gsfc.nasa.gov/jason1.html>

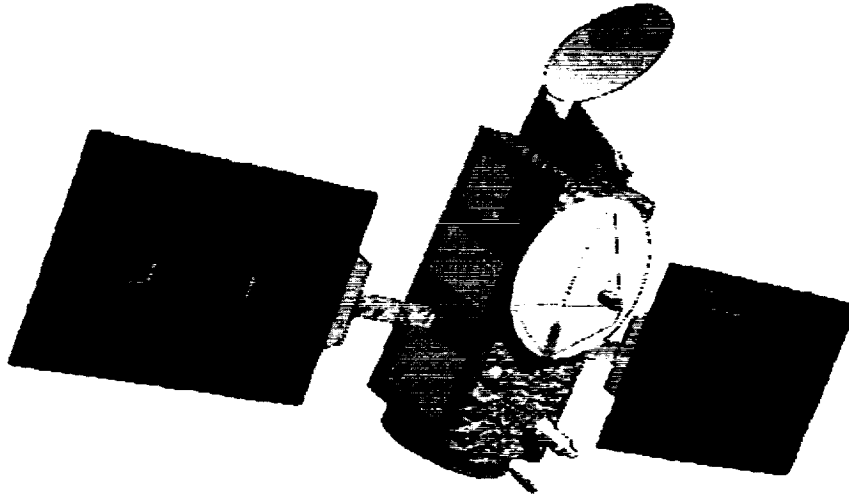

Figure 2.4-2a Jason Satellite

ADEOS-II

The ADvanced Earth Observing Satellite 2 (ADEOS-2) Mission is a joint international program like its successor, ADEOS-1. The mission will support the monitoring of global environmental changes while continuing and furthering the broad-ranging observation technology created by ADEOS-1. ADEOS-2 will carry the following instrumentation:

1. Advanced microwave scanning radiometer
2. Global imager
3. Improved limb atmospheric spectrometer
4. Seawinds
5. Polarization and directionality of earth reflectance
6. Retroreflector array

The corner cubes are symmetrically mounted on a hemispherical surface with one nadir-looking corner cube in the center, surrounded by an angled ring of eight corner cubes. This will allow laser ranging in the field of view angles of 360 degrees in azimuth and 60 degrees elevation around the perpendicular to the satellite's -Zs earth panel. The array design is identical to that of GFO-1 and ADEOS-II.

Additional information on ADEOS-II can be found at:

<http://ilrs.gsfc.nasa.gov/adeos2.html>

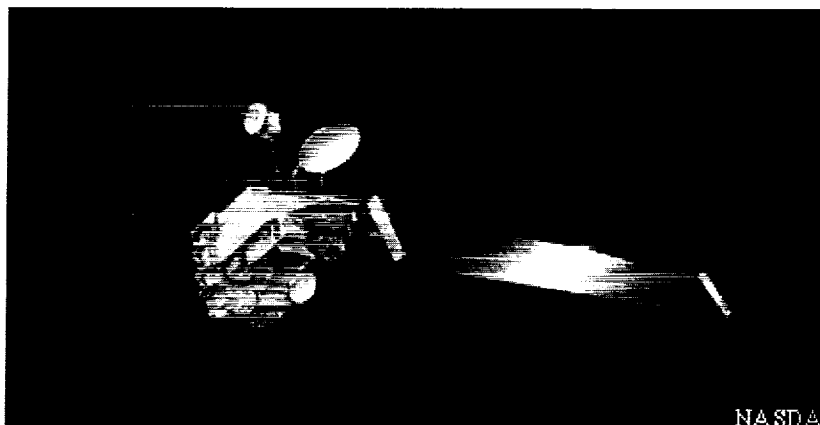

Figure 2.4-3a ADEOS-II Satellite

Vegetation Canopy Lidar (VCL)

The VCL mission will provide a characterization of the three-dimensional structure of the Earth including (1) landcover for modeling, monitoring and making predictions about the terrestrial ecosystem and climate modeling and (2) a global reference data set of topographic spot heights and transects. The mission will measure:

1. vegetation canopy top height to less than 1 m,
2. vertical distribution of intercepted surfaces,
3. ground surface topographic elevations to less than 1m

Measurements will be used to create a variety of gridded and ungridded data products. High resolution grid will be 2 km x 2 km; low resolution grid will be 1° x 1°.

Additional information on the VCL Mission can be found at:

<http://essp.gsfc.nasa.gov/vcl/>

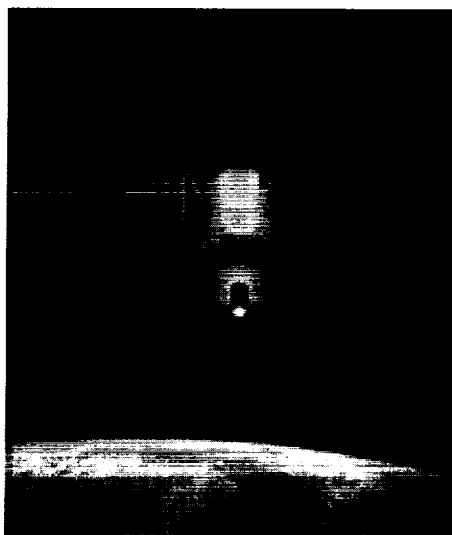

Figure 2.4-4a VCL Satellite

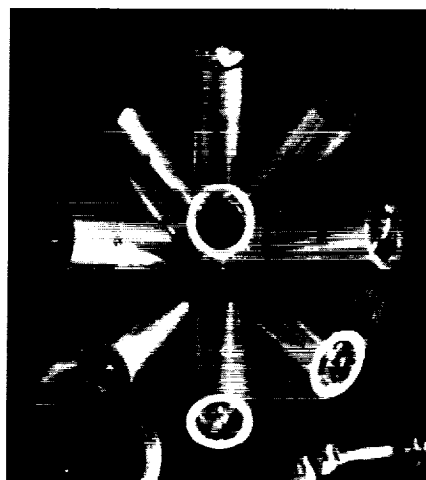

Figure 2.4-4b VCL SLR Retroreflector Array

Envisat

ENVIRONMENTAL SATellite (EnviSat) -1 is the successor to the European Space Agency (ESA) Remote Sensing Satellites ERS-1 and ERS-2. It will provide continuity with most of the ERS-1, 2 altimeter and SAR measurements and adds significant new capabilities. The mission will provide long term data sets for both climatological and environmental research. EnviSat-1 mission will monitor and support studies of the Earth's environment and climate changes; the management and monitoring of the Earth's resources, both renewable and non-renewable; and the development of a better understanding of the structure and dynamics of the Earth's crust and interior.

SLR will be used to calibrate the radar altimeter through precision orbit for ocean height data for monitor global ocean circulation, regional ocean current systems, and the study the marine gravity field.

Envisat will carry the following instrumentation:

1. Michelson Interferometer for Passive Atmospheric Sounding (MIPAS);
2. Global Ozone Monitoring by Occultation of Stars (GOMOS);
3. SCanning Imaging Absorption spectrometer for AtMospheric Cartography (SCIAMACHY);
4. MEidium Resolution Imaging Spectrometer (MERIS);
5. Advanced Along Track Scanning Radiometer (AATSR);
6. Advanced Synthetic Aperture Radar (ASAR);
7. Radar Altimeter 2 (RA-2);
8. MicroWave Radiometer (MWV);
9. Doppler Orbitography and Radiopositioning Integrated by Satellite (DORIS);
10. RetroReflector Array (RRA);

The corner cubes are mounted symmetrically on a hemispherical surface with one nadir-looking corner cube in the center, surrounded by an angled ring of eight corner cubes. This will allow laser ranging in the field of view angles of 360 degrees in azimuth and 60 degrees elevation around the perpendicular to the satellite's -Zs earth panel. The design is identical to the ERS-1 and ERS-2 reflectors.

Additional information on Envisat can be found at:

<http://ilrs.gsfc.nasa.gov/envisat.html>

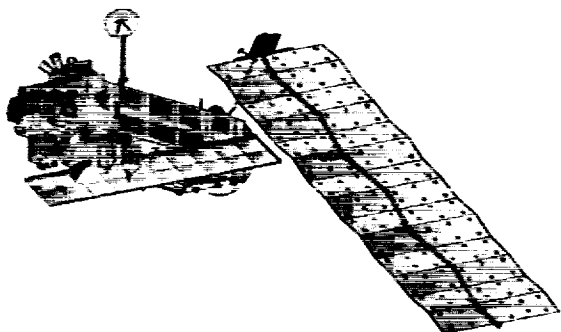

Figure 2.4-5a Envisat Satellite

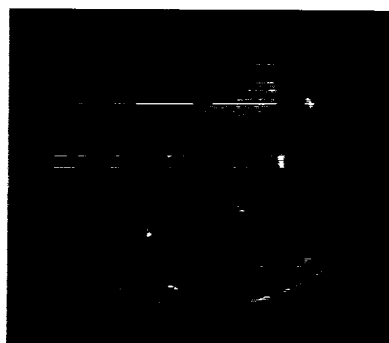

Figure 2.4-5b Envisat SLR Retroreflector Array

ICESat (GLAS)

The Ice Cloud and land Elevation Satellite (ICESat) begins with a launch on a Delta II (Model 7320) Expendable Launch Vehicle (ELV) in July 2001, into a near polar Low Earth Orbit (LEO) at an altitude of 600 km with an inclination of 94 degrees. The spacecraft accommodates the GLAS instrument which is currently estimated at a mass not to exceed 300kg and power of 330 W (each including 20% contingency), to fully achieve the EOS requirements.

The Geoscience Laser Altimeter System (GLAS) is an integral part of the NASA Earth Science Enterprise (ESE). GLAS is a facility instrument designed to measure ice-sheet topography and associated temporal changes, as well as cloud and atmospheric properties. In addition, operation of GLAS over land and water will provide along-track topography. GLAS will be carried on the Ice, Cloud and land Elevation Satellite (ICESat), scheduled for launch in July 2001.

The laser altimeter measures the time required for a laser pulse of 5 nanosecond duration to complete the round trip from the instrument to the Earth's surface and back to the instrument. This time interval can be converted into a distance by multiplying with the speed of light, and the one-way distance can be obtained as half the round trip distance. With the position of the instrument in space determined from a high accuracy Global Positioning System (GPS) receiver and from star camera and gyroscopes carried on the instrument/ spacecraft, the laser direction in space will be determined. From the GPS-determined position, the altimeter measurement and the laser pointing direction, the location on the surface of Earth illuminated by the laser pulse can be determined. The series of such laser spot, or footprint, locations provides a profile of the surface. Analysis of the sequence of laser spots over time enables the determination of temporal change in topography.

For more information on ICESat refer to:

<http://ilrs.gsfc.nasa.gov/icesat.html>



Figure 2.4-6a ICESat Satellite

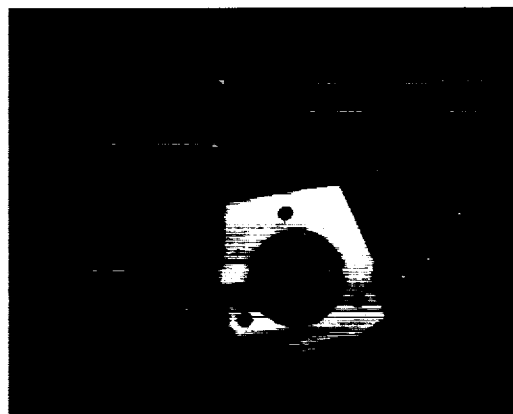

Figure 2.4-6b ICESat SLR Retroreflector Array

Gravity Probe B (GP-B)

Gravity Probe B will carry the relativity gyroscope experiment being developed by NASA and Stanford University to test two extraordinary, unverified predictions of Einstein's general theory of relativity. The experiment will check, very precisely, tiny changes in the direction of spin of four gyroscopes contained in an Earth satellite orbiting at 400-mile altitude directly over the poles. So free are the gyroscopes from disturbance that they will provide an almost perfect space-time reference system. They will measure how space and time are warped by the presence of the Earth, and how the Earth's rotation drags space-time around with it. These effects, though small for the Earth, have far-reaching implications for the nature of matter and the structure of the Universe. SLR and GPS will be used for precision orbit determination.

Gravity Probe B will carry the following instrumentation:

1. Four gyroscopes
2. Quartz telescope
3. GPS receiver
4. Retroreflector array

The retroreflector array is yet to be determined.

Additional information on Gravity Probe-B can be found at:

http://ilrs.gsfc.nasa.gov/gravity_probe_b.html

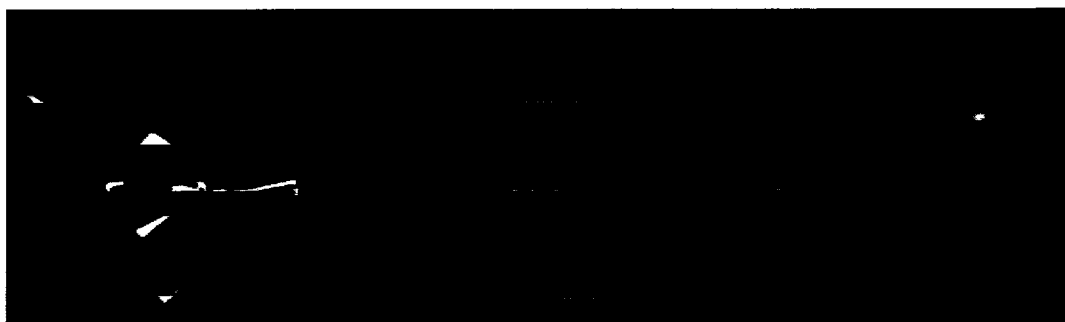

Figure 2.4-7a Gravity Probe-B

2.5 ILRS WEB SITE

Van Husson, *Honeywell Technology Solutions, Inc.*

BACKGROUND

The ILRS Web Site was developed to provide communication and coordination for the ILRS. The site is physically hosted on the NASA CDDIS computer at GSFC at:

URL: http://cddisa.gsfc.nasa.gov/ilrs/ilrs_home.html or <http://ilrs.gsfc.nasa.gov/>

Node: cddisa.gsfc.nasa.gov

IP Address: 128.183.102.102

For convenience, redundancy, and ease of traffic, the site is mirrored at the Communication Research Laboratory (CRL) in Japan at:

http://galileo.crl.go.jp/ilrs/ilrs_home.html

and the EUROLAS Data Center in Germany at:

http://www.dgfi.badw-muenchen.de/edc/ilrs/ilrs_home.html

Shortly after the establishment of the ILRS Central Bureau (CB) in May 1998, the CB formed a web team to begin providing cohesions. Fast access and easy navigation were the primary web site design considerations.

The web site hierarchical structure includes up to five levels. The top level (level 0) contains the home page, the web site search and the site map. The next level down (level 1) contains the main site categories:

- About the ILRS, Working Groups,
- Satellite Missions,
- Station/Sub-Networks,
- Data Products,
- Science/Analysis,
- Reports,
- Frequently Asked Questions (FAQ),
- Contact Information,
- Links, and
- What's New.

The lower levels (i.e., levels 2, 3, and 4) contain more detailed information about their respective parent categories.

The ILRS web site went on-line in early September 1998 and was demonstrated, a week later, at the 1st ILRS meeting held in Deggendorf, Germany in conjunction with the 11th International Workshop on Laser Ranging.

CURRENT STATUS

The site has been under continuous development based on user feedback to better facilitate information exchange and to minimize site maintenance. To date three types of features (cosmetic, functional, and science presence) have been added to the site which include:

- web-based forms (join the ILRS, mission support request, change ILRS associate directory information)
- interactive database queries (station tracking statistics by year and satellite)
- ILRS e-mail exploders
- the ILRS Quick Reference Card (see Section 8.2)
- cross-referenced tables containing station, satellite, and prediction information
- the ILRS Library (see Section 2.7)
- the ILRS bibliography
- the ILRS science brochure (see Section 2.8)
- expanded external related science links.

FUTURE DEVELOPMENTAL ACTIVITIES

Future development activities of the web site include:

- a knowledge base (i.e., symptoms and causes of poor performance)
- dynamic content created automatically when information databases are updated
- consistent web page format
- station site information logs
- station status updates
- mission support requests and mission support plans
- improved search capability
- improved and standard navigation scheme
- near real time updates of both mirrored sites
- spacecraft center-of-mass algorithms

- a history of satellite priorities and maneuvers
- final campaign station performance statistics
- expanded and more current WG and CB activities
- annual reports

The web site team members are listed below:

Carey Noll, *NASA CDDIS*

Mark Torrence, *Raytheon ITSS*

Peter Dunn, *Raytheon ITSS*

Jennifer Beall, *Raytheon ITSS*

Van Husson, *Honeywell Technical Solutions, Inc.*

Michael Pearlman, *Harvard-Smithsonian Ctr. for Astrophysics*

Paul Stevens, *Honeywell Technical Solutions, Inc.*

2.6 NETWORK PERFORMANCE EVALUATION

Van Husson, *Honeywell Technology Solutions, Inc.*

CURRENT ACTIVITIES

The ILRS Central Bureau (CB) is responsible for network performance evaluation and coordination of data problem resolution. The data team at HTSI, part of the CB, has developed diagnostic tools (i.e., range bias, time bias, data format, and data integrity checks) using the weekly orbital solutions from the analysis centers and key station processing parameters contained in the normal point data. These quality assessment tools have evolved from earlier work of the NASA Data Engineering Team established under the Crustal Dynamics Project.

When the diagnostic procedures indicate a potential problem, an investigation is initiated. The investigation involves close coordination with the analysis centers, station operations, engineering, and sometimes the broader CB team. If the data problem is recoverable, it is documented and communicated to the community. The data correction algorithm is published on the ILRS web site and added to the historical data problem listing.

The CB generates the quarterly global performance report card, which is available from the ILRS web site at:

<http://ilrs.gsfc.nasa.gov/performance.html>

The report card contains metrics for each station, which are evaluated by their comparison to established ILRS performance standards. The performance goals are divided into three categories (data quantity, data quality, and operational compliance) and have evolved from the performance guidelines presented at the Shanghai 10th International Workshop on Laser Ranging in November 1996. The last report card in 1999 appears in Section 8.4.

FUTURE ACTIVITIES:

The CB continues to enhance its performance assessment tools for more sensitive diagnostics. These enhancements include:

- aggregated station LAGEOS range and time biases to identify temporal trends
- comparisons of analysis centers aggregated LAGEOS range and time bias estimates and station coordinates
- refined station meteorological data integrity checks based on historical data
- a knowledge base of performance problem symptoms and their causes

The major goal of the CB engineering team is to continue to push data quality assessment responsibility to the stations (operations and engineering). The CB will continue its ongoing training in this area to assist stations by providing performance evaluation algorithms and by giving presentations at ILRS meetings and workshops.

2.7 ILRS LIBRARY

Mark Torrence, *Raytheon Information Technology and Scientific Services*

The ILRS maintains a library of information in hardcopy form and an online bibliography of references to articles and presentations that are of interest to the scientific, analytical, and engineering SLR commentates.

The library's hardcopy documents, which are located in Boston at the SAO, fall into the following categories:

- ILRS documents (2 volumes)
- SLR Subcommission reports (14)
- CSTG Bulletins (4)
- CSTG SLR/LLR Subcommission reports (2)
- Laser ranging workshop reports (2nd through 9th)
- program planning and review documents (16)
- SLR site information catalogue, retroreflector array transfer function (10)
- atmospheric refraction (1)
- mission support plans (8)
- SLR instrumentation information not from workshops (3)
- WEGENER documents (15)
- Asia-Pacific Space Geodynamics Program (APSG) documents (2)
- project reports (2)
- collocation reports (3)
- meeting reports (1)
- "Proceedings of the International Workshop on Geodetic Measurements by Collocation of Space Techniques on Earth", Communication Research Laboratory, Koganei, Japan, January 1999.

A complete citation list of the aforementioned hardcopy documents can be found at:

<http://ilrs.gsfc.nasa.gov/science.html>

on the ILRS web site.

The ILRS online bibliography currently has 2644 citations and is organized both alphabetically and by year of the citation. References are from the years 1966, 1971, 1975, and 1977 through the present. The bibliography can be found at:

<http://ilrs.gsfc.nasa.gov/science.html>

2.8 SCIENCE COORDINATOR REPORT

Mark Torrence, *Raytheon Information Technology and Scientific Services*

As established by the ILRS governing board, the science coordination activity of the ILRS is to:

- enhance science dialogue
- promote SLR goals and capabilities
- enhance the program/mission coordination and response
- promote multi-disciplinary dialogue
- help define and focus SLR science and technology goals
- help evaluate and plan for new technologies
- operate proactively to stimulate new or improved science products.

During the first year of the ILRS, a web page for science was made

<http://ilrs.gsfc.nasa.gov/science.html>

and a brochure describing SLR and its contributions to Earth science

<http://ilrs.gsfc.nasa.gov/slrover.pdf>

was updated. Also, an online bibliography of SLR related publications of SLR related geophysical, orbit determination, oceanographic and technology developments has been constructed (*see previous section*).

Brief presentations were made at each ILRS general meetings concerning how SLR contributes to scientific knowledge about the solid Earth and its' surface, about Lunar science, and to tests of relativity. SLR is and can continue to make unique contributions to knowledge of the temporal variations in the geopotential, to the maintenance of Earth scale, to the determination of Earth center of figure, and reference frame.

Additionally, SLR enhances the determination of Earth Love numbers and their frequency dependence, the refinement of low and intermediate harmonics of the static geopotential, the determination of the Earth's total mass, and vertical processes. Understanding the temporal changes in the Earth's gravitational field provides global constraints on the mass movements and exchanges occurring within the Earth-hydrosphere-atmosphere systems. SLR has made unique contributions to and can still enhance the resolution of the determination of the long wavelength non-tidal component of the temporal variations of the geopotential.

The static and dynamic Earth gravity model is used not only to perform precise orbit calculations, but also to act as a boundary condition on the mass distribution within the Earth, and for ocean dynamics. The variation of the ocean's surface from an equipotential surface requires removal of the geoid signal to yield a direct estimate of ocean circulation and isolation of the dynamic ocean topography.

Analysis of SLR data contributes to the estimation of the anelastic response of the solid Earth at tidal frequencies. The engineering community of the ILRS was encouraged to continue to improve the measurement accuracy to the few millimeter level allowing SLR to continue to contribute to scientific research.

Future science coordination activities will focus on the promotion of the unique contributions of SLR to science, and to the assessment of the evolving needs of the science community. This activity will participate in the formulation of a methodology to quality control science products and to provide standard test data sets for the analysis centers.

SECTION 3

WORKING GROUP REPORTS

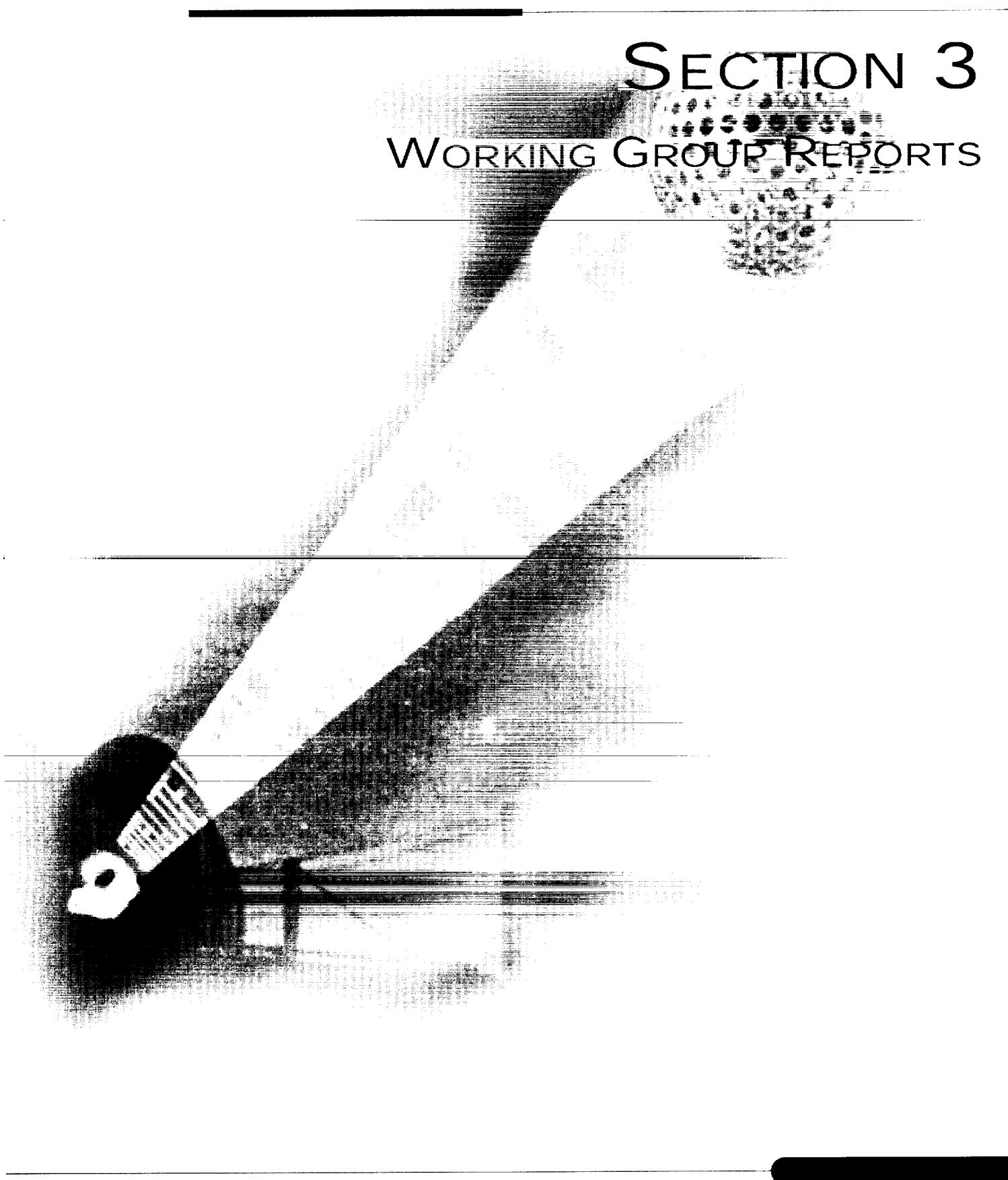

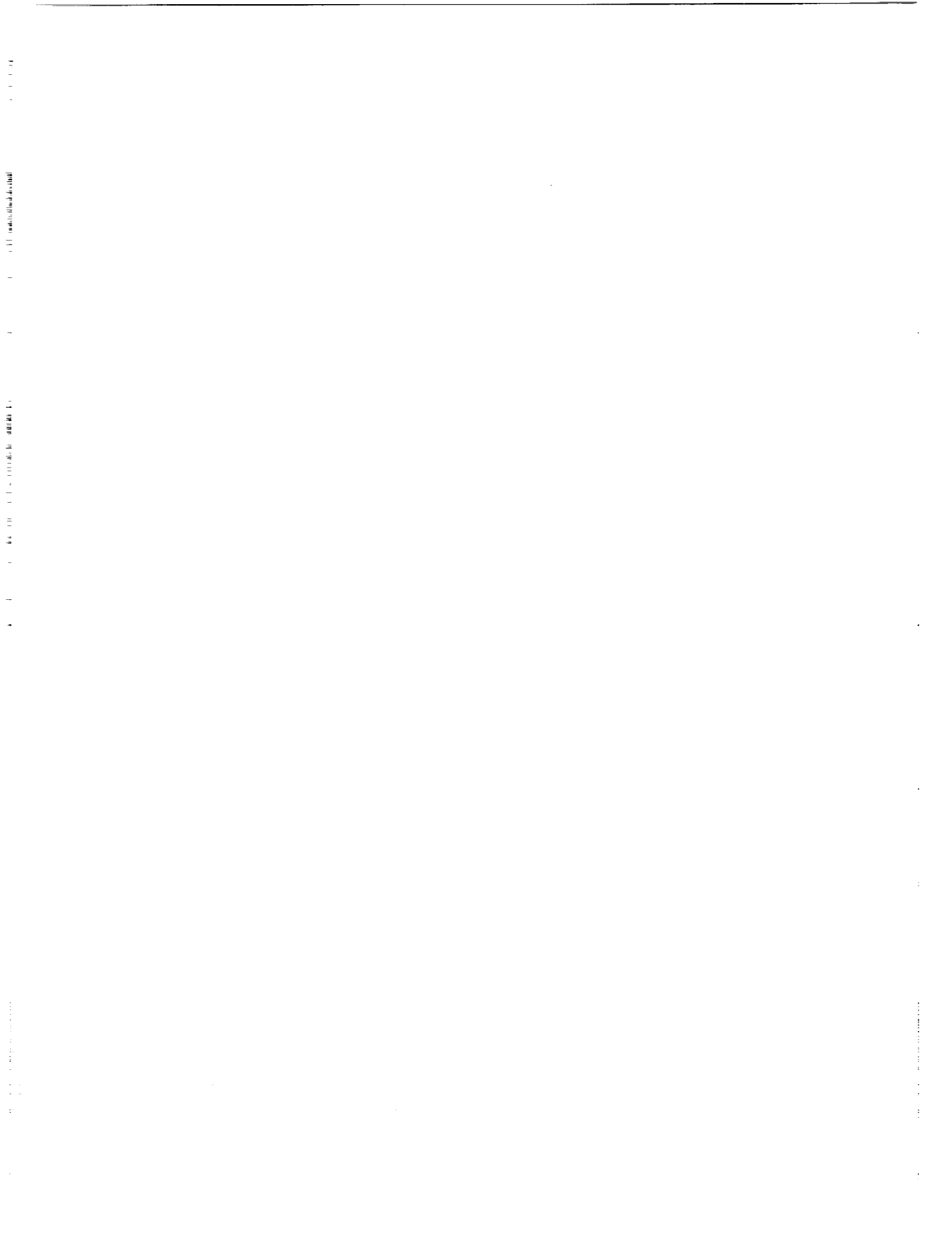

SECTION 3 - WORKING GROUP REPORTS

The Governing Board, at its discretion, can create or disband Working Groups. A Working Group (WG) may be either permanent (Standing) or temporary (Ad-Hoc) in nature. Standing Working Groups are created by the GB to carry out continuously evolving business of the ILRS. Occasionally, Ad-Hoc Working Groups are appointed to carry out special investigations or tasks of a temporary or interdisciplinary nature.

The Coordinator of each Standing WG is selected by the GB from amongst its members to ensure close coupling of the WG with the GB and its goals. The WG Coordinator can independently appoint additional members to the WG from among the other GB members, ILRS Associate Members or ILRS Correspondents (see below). The WG Coordinator may also designate a Deputy to act on his/her behalf in his/her absence. All GB members, with the exception of ex-officio members, Chairperson and IERS representative to the ILRS are required to serve on at least one of the Standing Work Groups.

The coordinator for Ad-Hoc Working Groups may be chosen, at the discretion of the Board, from outside its membership in order to best fulfill the goals of that WG.

Currently the Governing Board has established Standing Working Groups for:

- Missions
- Data formats and procedures
- Networks and Engineering
- Analysis

The Governing Board has also established an Ad-Hoc Working Group for Signal Processing.

3.1 MISSIONS WORKING GROUP

Scott Wetzel, *Honeywell Technology Solutions, Inc.*

Hiroo Kunimori, *Communications Research Laboratories*

INTRODUCTION

The Missions Working Group (MWG) was formed at the first ILRS meeting in Deggendorf, Germany in September 1998. Since then, the MWG has had two formal meetings, at the ILRS meeting in The Hague, the Netherlands in April 1999, and at the ILRS meeting in Florence, Italy in September 1999. Additionally, the MWG has had a number of ad hoc discussions via e-mail or telephone, to discuss current issues such as the approvals of request for support for new satellite missions and for intensive tracking campaigns.

The following sections describe the charter of the MWG, the membership, past activities, and continuing projects that the MWG addressed in the past year.

CHARTER

An SLR system can only track one satellite at a time. There has been a steadily growing number of new satellites with many different tracking requirements requesting SLR support of the past 5 years. As this number has increased, the need has increased for an organized mechanism to review all requests for SLR support of future missions and campaigns and to ensure that the currently supported missions still require SLR tracking. This ILRS Missions Working Group is tasked to review the needs of current and future SLR missions and to make SLR tracking support and priority recommendations to the ILRS Central Bureau and Governing Board.

The Central Bureau refers Mission Support Request Forms submitted for new satellites to the MWG. The MWG reviews them for adequate scientific or engineering relevance and sufficient justification for laser tracking support. Additional requirements such as SLR temporal and spatial coverage, prediction services, data processing and community interest are reviewed. Special mission requirements such as time biases, drag functions, liberating functions, modes of calibration, accelerated data submissions, and organization of the data flow from the data centers to the mission analysis centers are reviewed for relevance and compliance with ILRS capabilities.

Whenever the normal procedures and formats are inadequate for proper support of a new mission, the MWG will try to work out possible solutions in cooperation with the Mission sponsor and the other Working Groups.

The MWG proposes to the ILRS Governing Board the acceptance or refusal of a new or modified mission, based on the documents submitted by the mission sponsor (including a mission plan and the current workload of the network). Prior to making a recommendation to the

Board, the MWG consults with the Network and Engineering, Data Format, and Analysis Working Groups as necessary.

The MWG recommendation to the ILRS Governing Board includes any changes in the current priority list required to accommodate the new missions

The full charter for the Missions working Group can be found at:

http://ilrs.gsfc.nasa.gov/missions_wg_charter.html

MISSIONS WORKING GROUP MEMBERSHIP

Name	E-Mail	GB Member	Position
Hiroo Kunimori	kuni@crl.go.jp	Yes	Coordinator
Francois Barlier	francois.barlier@obs-azur.fr	Yes	Deputy Coordinator
Peter Shelus	pjs@astro.as.utexas.edu	Yes	GB Appointee
John Degnan	jjd@ltpmail.gsfc.nasa.gov	Yes	GB Appointee
Scott Wetzel	scott.wetzel@honeywell-tsi.com	No	
Pippo Bianco	bianco@asi.it	No	
Vladimir Vassiljev	lavaser@orc.ru	No	
Ulrich Schreiber	schreiber@wetzell.ifag.de	No	

ACTIVITIES

Meetings

Two MWG splinter group meetings were held during the past year: one at the Hague during the EGS meetings in April 1999 and the second at the SPIE meetings in Florence, Italy in September 1999.

The Hague Meeting

At the Hague meeting the following issues were discussed: The charter and the membership of the MWG were presented. The Mission Support Request Form was renewed and approved for installation on the ILRS web site in interactive form. The Mission Request Form can be found at:

<http://ilrs.gsfc.nasa.gov/ilrssup.html>

The first use for the new form was completed by the SUNSAT mission. The form was also sent to the IRS-P5 (India) and VCL (NASA) missions to be completed for submission. A description of the mission approval process is found in Figure 3.1-1

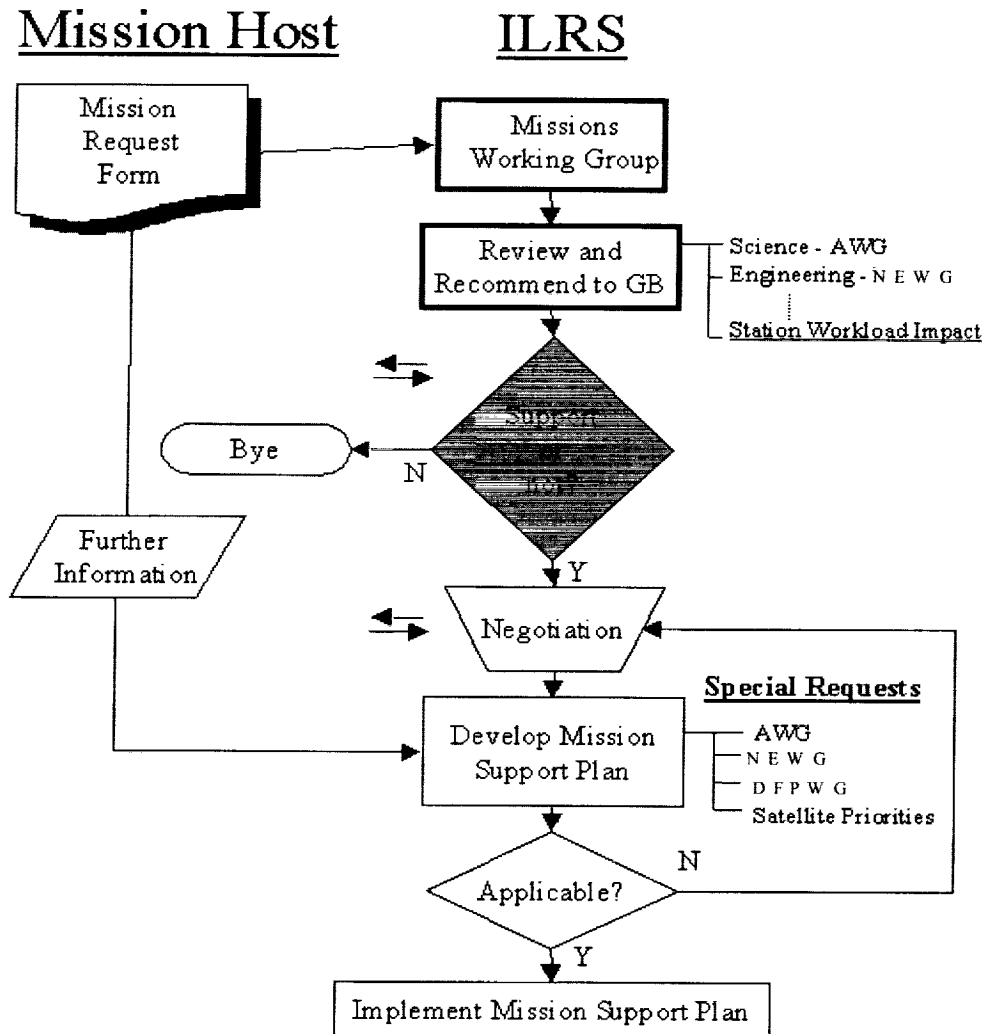

Figure 3.1-1 Procedures for New Campaigns/Missions

Following approval by the Governing Board, the next step is the development of a tracking support plan. It was agreed that new missions should submit a preliminary form early so that the MWG and the Governing Board can provide early feedback and suggestions. A final version of the form can be submitted closer to launch. It was suggested that requestors of new campaigns using satellites already in orbit should also submit a Missions Support Request Form using the relevant fields. Several of the working groups pointed out the need for standardization and documentation of the center-of-mass corrections.

Other issues discussed included some unresolved issues on the GLONASS numbering system, but it wasn't clear if this adversely affected SLR tracking. Further investigation on the topic would continue.

The Florence Meeting

At the Florence meeting the topics of discussion included: (1) provisions for handling special requests as part of mission support, (2) criteria for ILRS acceptance of new missions, (3) determination of future tracking priorities, and (4) development of a flow diagram of procedures for new missions.

The approval procedures for campaigns conducted over the previous 6 months were reviewed with an eye toward the large number of new missions in the near future (twelve new missions were anticipated over the next three years). Mission support requests for CHAMP and VCL were under MWG review. Discrepancies in the several GLONASS numbering systems continue to cause confusion. The Missions Working Group and the Central Bureau agreed to work through a standard numbering system for the SLR community to use for its operational activities. Spacecraft center-of-mass changes during mission lifetime (due to expenditure of fuel) will be investigated and worked with the Signal Processing (Ad Hoc) Working Group.

Campaigns

Requests for special campaigns have been approved for the following satellites: GEOS-3, ERS-1, Etalon, BEC, Sunsat, and GFO-1. Brief summaries follow.

The new ILRS Board approved a campaign on GEOS-3 for gravity field modeling in September 1998. The campaign began in October 1998 and concluded in April 1999 with over 2200 passes tracked. The ERS-1 campaign was requested for the period beginning from July 1998 through the end of 1999 to support the tandem SAR Mission with ERS-2. The failure of the radio tracking system early in the ERS-1 mission had left SLR as the only method of POD for the satellite. As with all campaigns, ESA was required to reapply for SLR support on an annual basis and to provide periodic updates on the status and usefulness of the SLR data.

An Etalon campaign was requested by the WPLTN for continuing geodetic modeling in the Western Pacific region. The campaign covered the month of November 1999. A total of 297 Etalon segments were received from the global SLR community in support of the brief campaign. Due to the success of the campaign, the WPLTN is anticipating future monthly campaigns on an annual basis.

An 18-month BEC campaign was proposed by the University of Texas at the ILRS meeting at the Hague in April. A mission request form was received and approved with the requirement of 6 month data reviews to ensure adequate SLR coverage was being provided to support the science objectives of the mission. The campaign began in July 1999 and is expected to conclude in December 2000.

An ongoing Sunsat campaign was extended through March 2000 by the Governing Board in support of the GPS/SLR intercomparison experiment. The Sunsat mission was not recommended for full mission status as it had no long term goals that required SLR support. The Board is open to extensions of the campaign to meet program needs.

GFO-1 - (NASA)

The GFO-1 altimeter satellite, launched by the US Navy in April 1998 continued its shakedown and diagnostic phase. The MWG recommended campaign status at high priority while the Navy and their contractors worked to resolve a number of on-board problems. The tracking campaign and the status of the satellite are being reviewed every six months.

WORK IN PROGRESS

Continued efforts are required by the MWG to develop:

- A more automated and user friendly Mission Support Request Form
- A Mission Support Plan Template to help satellite hosts in mission planning
- A procedure to periodically (1) review mission requirements and applicability of SLR to meeting these requirements and (2) require satellite owners or key science and technical contacts to justify continued SLR support

Issues such as SLR coverage and data volume will be reviewed, whole arc or pass segmentation may be planned to support a rapidly growing number of missions. Also to be considered would be periodic intensive tracking campaigns to relieve the high number of #1 priority missions.

Mission Name	Support Requester	Application	Planned Launch Date	Mission Duration	Received Mission Request Form
CHAMP	GFZ	Gravity and magnetic field mapping	July 2000	5 years	Yes
JASON-1	CNES/NASA	Earth sensing	November 2000	5 years	No
ADEOS-II	NASDA	Earth sensing	December 2000	3 years	No
Grace	NASA/GFZ	Gravity	Fall 2001	5 years	No
IceSat (GLAS)	NASA	Earth sensing	July 2001	3-5 years	No
Envisat-1	ESA	Earth sensing	June 2001	5 years	No
VCL	NASA	Earth sensing	September 2001	18 Months	Yes
Gravity Probe B	NASA	Relativity	May 2002	1-2 years	No
ALOS	NASDA	Earth sensing	February 2003	3 years	No
ETS-VIII	NASDA	Experimental	July 2003	3 years	No

Table 3.1-1 Planned Future Missions

3.2 NETWORKS AND ENGINEERING WORKING GROUP

Werner Gurtner, *Astronomical Institute of Berne*

MEMBER LIST

Name	E-Mail	GB Member	
Werner Gurtner	werner.gurtner@aiub.unibe.ch	yes	Coordinator
Graham Appleby	gapp@ite.ac.uk		
David Carter	dcarter@eib1.gsfc.nasa.gov	yes	
John Degnan	jjd@ltpmail.gsfc.nasa.gov	yes	
Howard Donovan	howard.donovan@honeywell-tsi.com		
Van Husson	van.husson@honeywell-tsi.com		
Georg Kirchner	kirchner@flubpc04.tu-graz.ac.at		
Rolf König	koenigr@dfd.dlr.de		
Hiroo Kunitomori	kuni@crl.go.jp	yes	
Mike Pearlman	mpearlman@cfa.harvard.edu	yes	
Ulrich Schreiber	schreiber@wetzell.ifag.de		
Wolfgang Schlüter	schlueter@wetzell.ifag.de	yes	Deputy coord.
Fumin Yang	yangfm@center.shao.ac.cn	yes	
Tom Zagwodzki	thomas.w.zagwodzki@gsfc.nasa.gov		

PRIMARY TOPICS

The following major topics for the Working Group activities have been defined based on the Terms of Reference. In order to distribute the workload, each working group member has been assigned one or more fields of activities and chairpersons have been assigned for each activity.

The six primary topics of activity (as defined in the Terms of Reference) are distributed among the Working Group members as follows.

1. Provide a communications link between the analysis community and the global network (*Yang, Koenig, Appleby*)
 - Find out what feedback is desired by the stations, what feedback or information already exists and who works on or initiates improvements of this feedback
2. Facilitate ranging data problem and/or anomaly resolution (*Koenig, Husson, Donovan*)
 - Generation of a catalogue of quality checks performed by the various analysis centers. Specification of the feedback needed by the tracking sites.
 - What is already available and who actually can “routinely provide” such feedback?
 - Development of a consistency and format check program for ILRS normal point files (to be run on-site)

3. Review and maintain the system configuration database (*Husson, Gurtner*)
 - Development of a new site/system log form
4. Maintain a “knowledge base” (*Pearlman, Kunimori, Degnan*)
 - Knowledge data base: Online collection of papers, reports, descriptions, manuals, whatever
 - Generation of a catalog of satellite-specific tracking properties
5. Perform engineering analyses in support of new missions and network scheduling (*Schreiber, Carter, Husson*)
 - Example: Spacecraft link calculation
6. Coordinate and catalyze engineering improvements within the global network (*Kirchner, Degnan, Zagwodzki, Donovan*)
 - Monitor reported developments, tests of new equipment, etc.
 - Encourage the respective specialists to help prepare well formulated, summarized and to a certain extent educational proposals for improvements to be distributed to the network

POSSIBLE ADDITIONAL TOPICS:

- Initiate prediction flow chart (Special working group)
- Define a procedure to quickly request highest priority tracking of specified passes
- Define a procedure to prevent the network from ranging to a satellite during a specified period
- Define a procedure to quickly contact the operators with urgent messages.

WORK IN PROGRESS

ILRS Site and System Information Form

W. Gurtner has developed a proposal for a site log form similar to the well-established site log form routinely used by the International GPS Service for the permanent GPS tracking stations. The proposal was review by several working group members and presented at the Florence General Assembly in September 1999. After the Assembly four stations were asked to fill out the form as a final check and as basis for an explanatory supplement.

In early 2000 the Central Bureau should request all stations to fill out the form.

The form collects information about the following items:

- Form
- Identification of the Ranging System Reference Point (SRP)

- Site Location Information
- General System Information
- Telescope Information
- Laser System Information
- Ranging Electronics
- Tracking Capabilities
- Calibration
- Time and Frequency Standards
- Preprocessing Information
- Aircraft Detection
- Meteorological Instrumentation
- Local Ties and Eccentricities
- Local Events Possibly Affecting Computed Position
- On-Site, Point of Contact Agency Information
- Responsible Agency
- Additional Information

Four-Character Site Code

A list of new SINEX compatible four-character acronyms for the SLR sites is in preparation. These acronyms would replace the four-digit CDP code in file names, tables and lists, etc., to improve the readability.

Knowledge Data Base

The Central Bureau has established an on-line bibliography of SLR related papers and articles including all of the Laser Workshop articles (except Workshop #1). Many of the most recent articles are on line and links may be added if deemed appropriate. Search categories will be established for the bibliography to facilitate access to the large amount of scientific, technical and operational information.

Many of the ILRS responsible entities, rules, regulations, constraints, algorithms, forms etc, are being collected and put on line.

Databases will be developed for all of the station information that will be forthcoming from the completed site survey forms and other queries that are underway.

Real-time Status Exchange

A description of the procedures used by the EUROLAS subnetwork to exchange current SLR system status information and satellite tracking activity (including actual time bias) has been distributed within ILRS by SLRMail 372 (see also EUROLAS contribution in Section 4.1).

Link Budget

A web-based program for satellite link budget calculations has been prepared by Stefan Riepl at:

<http://www.wettzell.ifag.de/publ/linkbudget/linkbudget.html>

which computes the number of return photons expected as a function of SLR system parameters and the satellites. The web pages also show a standardized link budget relative to the Lageos satellite for a selection of satellites.

Calibration Workshop

Ulrich Schreiber, Wettzell, organized a joint EUROLAS/ILRS two-day workshop on "System Calibration" in Florence, Italy (September 23/24, 1999).

Other activities

Since there is considerable overlap between the areas of interest of our working group and those of other groups (Data Formats and Procedures, Prediction Subgroup), close contacts have been maintained with those groups.

3.3 DATA FORMATS AND PROCEDURES WORKING GROUP

John Luck, *Australian Surveying and Land Information Group*

CHARTER

The following charter was ratified in January 1999 and updated on 7 May 1999 as a result of The Hague Data Formats and Procedures WG Meeting.

Objective

The objectives of the Data Formats and Procedures Working Group (DFP WG) are to:

- Standardize procedures affecting data up to generation of full-rate and normal point data.
- Maximize the efficiency of the process of generating the laser data, by ensuring that accurate predictions are available and that standardized software procedures are available to produce a uniform quality data product.
- Ensure that the data product contains all the information needed by the analyst, and that the data and related information are available for the analyst in a convenient form.

Role

Predictions

Document and maintain standards for:

- Force model and reference frame of IRV integrator.
- Format of IRV state vectors.
- Standard methods to correct IRVs for unmodeled forces.
- Standard format for time bias functions, drag functions, satellite maneuvers, etc..
- Standard software packages for generating predictions from IRVs.

The Working Group will endeavor to ensure that there are several groups within the network with the capability of generating IRVs and time bias corrections, and that there are efficient and rapid means of distribution.

Data Processing

Document and maintain the standard algorithm for:

- Formation of normal points.

The Working Group will endeavor to maintain standard software packages for fitting a trend function to pass residuals, or analyzing the distribution of pass residuals, and calculating various reference points (mean, peak, etc).

Station Information

Document and maintain formats for recording station information, such as:

- Eccentricity vectors
- Site occupancy details
- Changes to systems (e.g., SCH log files)
- Alternative operational configurations of stations (e.g., SCI log files)

Final Data Product Formats and Transmission Standards

- Maintain documentation of formats for the final data products, full-rate data (FR) and normal points (NP).
- Coordinate continuing review of formats, and if necessary revise.
- Document standards for transmission, including file naming conventions.

MEMBERSHIP

Name	E-mail (ilrsdftpwg@ilrs.gsfc.nasa.gov)
John Luck, Coordinator	johnluck@auslig.gov.au
Wolfgang Seemueller, Deputy Coordinator	Seemueller@dgfi.badw-muenchen.de
Ron Noomen, GB Appointee	ron.noomen@lr.tudelft.nl
Van Husson, CB Representative	dsgvsh@slral2.atsc.allied.com
Randy Ricklefs, LLR Representative	rlr@astro.as.utexas.edu
Graham Appleby	gapp@ite.ac.uk
Reinhart Neubert	neub@gfz-potsdam.de
Andrew Sinclair	Atsinclair@aol.com
Roger Wood	rw@gxvf.rgo.ac.uk
Vladimir Glotov	vd.g@g23.relcom.ru
Roland Schmidt	Rschmidt@gfz-potsdam.de

Brion Conklin resigned, October 1999

STUDY GROUPS

Signal Processing Working Group ("Tiger Team")

This team led by Graham Appleby was initially formed by the Data Formats and Procedures WG at its first meeting at the Second General Assembly at The Hague, the Netherlands to develop unimproved satellite center-of-mass corrections. It was subsequently established as an ad hoc Working Group in its own right by the Governing Board.

Predictions Study Group ("Lion Team")

The Predictions Study Group was also established under the leadership of Roger Wood at The Hague.

Objective

To review the way in which predictions are currently produced and distributed in order to improve the quality of predictions at the telescope and to provide them at a frequency appropriate to each satellite.

Tasks

- (1) Investigate the immediate benefits of building on the present IRV system by way of:
 - Computing fresh predictions daily;
 - Producing multiple IRVs per day;
 - Arranging for orbit-by-orbit re-prediction for difficult satellites.
- (2) For the longer term, examine the merits of supplying stations with fully-modelled predictions (by-passing IRVs) for every pass.

Report to ILRS making recommendations on how to proceed together with standards for procedures and formats, as required.

Membership

Roger Wood (leader), Brion Conklin (resigned), Werner Gurtner, Rolf Koenig, Jan McGarry, Chris Moore, Randy Ricklefs, Wolfgang Seemueller.

Progress to Date

With the broad aim of looking at the whole prediction cycle, it was agreed that it would be useful for the Central Bureau of ILRS to conduct a survey of observing stations, prediction centers and data centers to find out what is current practice for all aspects of predictions, and to hear from all

component parts of the network what they regard as strengths and weaknesses. It is recognized that it would be advantageous to speed up the data flow in all the links: observing station → data center → prediction center → data center → observing station and so on. A questionnaire will be distributed in early 2000.

The well-established system of prediction distribution by IRVs has much to recommend it: it is compact, robust and well-proven. However, it is now perfectly possible, utilizing the speed and efficiency of data traffic on the Internet, to make worthwhile improvements with only minimal changes to the IRV system. For example, it would be useful to amend Line 1 of the standard IRV format to give more uniform identification for the prediction centers which produce them (and to be identical with those used in Time Bias Functions). There are other data which might be included here, like information about the multiplicity (i.e. number of IRV sets per day) for cases where the time span is less than 24 hours.

By far the most dramatic improvement would be the wider production of IRVs daily, or even sub-daily for "difficult" satellites. The main questions are then the ability of the network as a whole to handle the increased traffic. Further automation of processing should make such increases transparent. For some stations where it is not easy to change quickly, it would be necessary to run the existing system in parallel with any new ideas.

In the more distant future (again especially for some of the planned low-flying missions) it may be necessary for stations to be able to accept geocentric XYZ files generated directly from the precise orbits computed at prediction centers. The benefits for the prediction centers are that they then do not need to compute IRVs from their precise orbits, a process which does inevitably cause some degradation in the precision inherent in those orbits. Observing stations will only have to make some minor adjustments to their software to allow direct use of these files by bypassing the IRV integrator. HTSI (for SLR 2000) and NERC (for GFZ-1 and other low satellites) have already been experimenting with this approach with promising results.

One other aspect of some of these new missions which may lead to better tracking by the SLR network is the fact that several of them have other position measuring systems (GPS, DORIS) on board, and the rapid utilization of data from these devices (having the great advantage of weather independence) could significantly improve data yield from SLR.

For data centers, the main issue will be handling the increased traffic. Some careful thought needs to be paid to the question of archiving predictions: are they to be regarded as truly ephemeral ephemerides and discarded as soon as the relevant date has passed, or should they be retained for later use? Now that prediction data are available in several FTP sites it would seem sensible to agree to a common directory structure (below some entry point) for all files; and further to standardize the naming conventions for prediction and other files.

All observing stations should be encouraged to move to using daily IRVs, especially for the GPS and GLONASS satellites and LAGEOS, where the results are excellent.

One very valuable addition to the ILRS Website has been the expansion of the information on prediction centers and the detail of what IRVs are available from whom at what frequency, together with hyperlinks to all sources. See:

http://ilrs.gsfc.nasa.gov/prediction_centers.html and

http://ilrs.gsfc.nasa.gov/prediction_types.html

Normal Point Study Group ("Jaguar Team")

This team led by John Luck was established at the meeting in The Hague. Having reached a conclusion, it was disbanded at the Working Group meeting in Florence, September 1999.

Objective

To test whether a significant proportion of normal points rejected by Analysis Centers contained low numbers of returns, and to make the appropriate recommendation to the Governing Board.

Membership

John Luck (leader), Graham Appleby, Richard Eanes, Gerd Gendt, Peter Dunn, Vladimir Glotov, Tim Springer, Jean-Claude Raimondo, Ron Noomen.

Conclusion and Recommendation

Data on normal point rejection rates for normal points constructed from 1, 2, 3, 4 and many individual returns were presented for ERS-1, ERS-2, WESTPAC, STARLETTE, STELLA, LAGEOS-1 and LAGEOS-2, by several Analysis Centers. The study found the following:

- a) the percentage rejected depends roughly on the inverse of the square root of the number of returns in the normal point
- b) only 30% of 1-return normal points are rejected;
- c) the Analysis Centers are detecting adequately the outliers among these sparse normal points.

Accordingly, the Study Group made the following recommendation was presented to the ILRS Governing Board: "The ILRS should make no restriction on the minimum number of returns used to generate Normal Points."

Refraction Formula Study Group

The Working Group was charged at the Florence meeting of the Governing Board with the task of setting up a study of the adequacy of the Marini-Murray formula for atmospheric propagation delay, and to promote the development of a new formula and methodology if necessary. This task is in hand at the time of writing.

BUSINESS ARRANGEMENTS

Meetings

Two meetings were held for the DFP WG and friends, immediately prior to ILRS GB meetings:

- (1) The Hague, Holland, 20 April 1999, 8:15-10:30 pm. This meeting discussed 23 agenda items, and produced decisions or positive action plans on all of them.
- (2) Florence, Italy, 21 September 1999, 6:30-10:00 pm. This meeting received reports from the Central Bureau and Study Group leaders, and discussed 10 agenda items.

These meetings were very useful, and enabled recommendations to be finalized for approval by the GB. It is proposed to continue this procedure.

ACTIVITIES OF THE DFP WG

A summary of the activities of the WG can be found on the ILRS Web Site at:

http://ilrs.gsfc.nasa.gov/data_activities.html

The initial activities dealt largely with tightening up existing formats and procedures, rectifying anomalies, providing standardized documentation via the Web site, and setting up study groups for the more serious questions.

All Web references below are preceded by <http://ilrs.gsfc.nasa.gov>.

Decisions Implemented

Official Names of Station Data Products:

To emphasize the official status of the ILRS in determining formats, the nomenclature for station products was changed as follows:

- ILRS NP for Normal Point format and data (formerly "CSTG ONP").
- ILRS FR for Full-Rate format and data (formerly "MERIT-II Full-Rate").

ILRS Normal Point Format and Algorithm:

The April meeting in The Hague ratified the existing CSTG ONP format adopted in March 1997. Conversion of all historical LLR Normal Point data to this format was accomplished by University of Texas by July 1999 - LLR files have their own interpretations in bytes 49-52.

The ILRS NP format is described in detail in /np_format.html, and its history dating back to Herstmonceux 1984 has been placed at /np_format_intro.html. The NP algorithm has remained essentially unchanged since the Herstmonceux Agreement. Details are at /np_algo.html.

The Central Bureau has developed “sanity checks” on NP data files submitted by stations, and has implemented them with the authority of the ILRS by notifying stations immediately of anomalies and format non-compliances. Examples of non-compliance include:

- Incorrect bin sizes per satellite.
- Single-shot precisions divided by \sqrt{n} .
- Bin boundaries not starting at 00:00:00 UTC + $k*(\text{binwidth})$.

ILRS Full-Rate Format Changes:

The official ILRS FR format at [/fr_format_v3.html](#) contains changes to the contents of several fields adopted as a result of the meeting in The Hague, April 1999.

- Data prepared with these new conventions must contain ‘3’ in the Format Revision Number (byte 129).
- The Wavelength field (bytes 65-68) conforms to the definition adopted for ILRS NP Header bytes 21-24.
- Normal Point Bin Size Indicator (byte 115) conforms to the definition adopted for ILRS NP Header byte 43.
- Epoch Time Scale Indicator (byte 121) includes ‘4’ to mean UTC determined by GPS time transfer or GPS timing receiver, where UTC for practical ILRS purposes is realized by USNO, BIPM or cognizant national authority.
- The Calibration and Configuration flags (bytes 126-128) are rearranged and slightly reinterpreted, to conform to ILRS NP Header bytes 45-47.

The WG suggested July 1, 1999 as an implementation date.

Format and Procedure for Notification of Satellite Maneuvers:

The adopted format is based on the D-PAF maneuver message, and is available at [/manoeuvre.html](#). The appropriate Prediction Center will advise the ILRS stations of upcoming maneuvers. The CB and Missions Working Group are to prevail upon all concerned mission operators to comply with the format and procedure. There is no consensus on how to spell it.

Drag Function Format and Procedure:

Since it is conceivable that drag functions such as those used for GFZ-1 will be required for some of the upcoming very low altitude missions, the format and algorithm developed for GFZ-1 have been adopted. The format is shown at [/drag_function.html](#) and the algorithm is described by Fortran subroutines available at [/drag_function_subroutines.html](#).

System Configuration (SCI) and System Change (SCH) Files:

The formats and procedures adopted in March 1997 are documented at [/sys_cong_proc.html](#). Stations were reminded that changes/updates to existing files require transmission of ONLY the new information (i.e. they should not re-send the whole file).

Prediction Centers and their Acronyms:

A list of Prediction Centers producing Tuned IRVs, together with their adopted 3-character acronyms and statements on how to access prediction files, has been placed at [/prediction_centers.html](#). A list of the satellites for which predictions are made by each Prediction Center, and the frequency of updating, can be found at [/prediction_types.html](#). These lists are prepared as a service to the stations, and to record the standard naming conventions to be adopted for Time Bias Functions, Drag Functions, Maneuver Notifications, and IRVs themselves.

Site Occupancy Designators and DOMES Numbers:

The Central Bureau has developed the process for the assignment and communication of Site Occupancy Designators (SOD) in a manner consistent with the IERS Directory Of MERit Sites (DOMES) Designators' requirements. The SOD numbering system and procedure for allocation of new SOD numbers are found at [/sod.html](#).

It was clarified during the Florence meeting that the last two digits of the CDP occupancy sequence number will be incremented when there is a new system occupation or when the system's eccentricities for a given monument have changed significantly (i.e. the change is greater than the uncertainty in the measurements in any of its components). A change in occupation number indicates there is new eccentricity information, which must be forwarded immediately to the CDDIS.

The DOMES numbering system and procedure are explained at [/domes_and_domex.html](#). Van Husson has compiled a cross-reference table of SOD and DOMES numbers for ILRS stations active at October 1999, at [/sod_domes.html](#). Ron Noomen has provided the complete historical cross-reference table, at [/sod_domes.xls](#).

System Status Monitoring:

Some stations seem to "disappear" for extended periods. The ILRS wishes to know if they need help, or whether the Data Centers can expect to receive a backlog of files at some future time. The Florence at the recommendation of the Working Group a weekly one-line "Station Status Report" was adopted. A station not submitting this report will be flagged as "non-operational" by the Central Bureau, which will investigate the cause if it persists. The procedure was inaugurated in February 2000 - see e-mail from Mike Pearlman to all stations, 10 February 2000: "Station Status Reporting - Required for All Stations." The CB will include the station status flags in its weekly tracking statistics reports.

Y2K:

The membership and components of ILRS were strongly advised to perform Y2K compliance testing well before the date rollover to January 1 2000. The ILRS published a NASA/HTSI Y2K Benchmark Report and allied documents. Nevertheless, there were a number of minor Y2K problems throughout the ILRS, which were quickly fixed.

Decisions Awaiting Implementation

Data Transmission Procedures:

The Data Center representatives at the Florence meeting agreed to codify the procedures for transmission of data from the stations, and retrieval from the Data Centers by the stations. Data access and file naming conventions are now available on the ILRS Quick Reference Card (see /ilrs_qrcard.doc). A summary of the data flows is presented in Section 6. The Predictions Study Group (Lion Team) is closely involved in specifying, codifying and advertising the requirements and procedures, with the aim of making all data transmissions as automatic and unambiguous as possible.

Standard Software Packages:

At the time of writing, the NASA/HTSI Operations Center is doing final testing and debugging on its new NP data format and data integrity checking routines. The algorithms for these checks were agreed at the Working Group meeting in Florence in September 1999. As well as checking such things as correct NP bin sizes per satellite, typical checks include sensible meteorological readings per station.

The WG has agreed in principle that it is responsible for having standard subroutines/packages prepared for such things as the computation of skewness and kurtosis, and the filtering and compression of raw data into ILRS NPs, when and if they become practicable or necessary. The routines would be written in standard, common computer languages for the popular platforms.

Future Actions Considered

SLR Data Product Holdings:

It has been proposed to debate the feasibility of having identical data (tree) structures below the entry point, for SLR information at both CDDIS and EDC. This would involve major restructuring of data product holdings.

Full-Rate Calibration Data:

The Signal Processing Working Group requested an examination of the need for ground-target calibration data to be made available on a return-by-return basis, and foreshadowed a request to incorporate the data in ILRS FR format.

ILRS FR and NP Format Conformance:

Is there merit in having both forms of data in the same format? Is it feasible? Should improved methods of data compression (e.g. Hatanaka) be adopted?

3.4 ANALYSIS WORKING GROUP

Ron Noomen, *Delft University of Technology*

INTRODUCTION

The International Laser Ranging Service (ILRS) was established in 1998. Its main tasks are to:

- coordinate the use of Satellite Laser Ranging (SLR) and Lunar Laser Ranging (LLR) instruments;
- coordinate the analyses of the observations obtained by these instruments, and provide for consistency and unambiguity of the results;
- provide a so-called Standard Solution, an official ILRS combined product; and
- stimulate the use and interpretation of SLR/LLR analysis products and promote the laser ranging community as a whole. Section 1 of this report has addressed these issues in more detail already.

The AWG focuses on analysis aspects of the laser range measurements in particular.

CHARTER

The charter of the Analysis Working Group (AWG) can be found on the ILRS web page at:

http://ilrs.gsfc.nasa.gov/analysis_wg_charter.html

and in summary they are:

- provide internal quality control on data analysis results;
- ensure analysis results compatibility with results obtained using other techniques;
- develop an official and combined ILRS data analysis strategy and analysis product(s);
- provide feedback to the network on performance;
- support ILRS in mission planning; and
- establish and maintain a knowledge base for the analysis community.

One of the most prominent scientific contributions of the laser ranging technique to the global geodetic and geophysical community is a time-series of solutions of Earth Orientation Parameters (EOPs; submitted to the International Earth Rotation Service IERS), and individual station coordinates and velocities (included in the models of the International Terrestrial Reference Frame ITRF).

During the last decade, new geodetic observation techniques (GPS, DORIS, GLONASS, etc.) have come to fruition and have significantly increased the number of individual contributions to

IERS/ITRF. This has necessitated a better coordination and definition of the products, and has encouraged quality improvements for all contributions. Very importantly, the combination of individual contributions is being done, more and more, individually for each technique. As a consequence, each technique is ultimately responsible for its own combination, quality control of the individual contributions and of the end product, and consistency with the results obtained by others techniques.

It is recognized that the great strength of the laser ranging technique is in the definition of scale and the determination of origin of the ITRF. It is thus likely that rapid monthly solutions for station coordinates will be of practical use as contributions to timely multi-technique reference frame determination which will support many geodetic research programs. In addition the computation of high-quality orbits for altimetry and SAR satellites will continue to be important. For all these products, high quality observations and analyses are crucial.

MEMBERS

The AWG currently consists of 16 members (status December 31, 1999) representing a wide variety of laser targets and satellite missions (Moon, LEO and MEO satellites), the large number of geophysical subjects that are being studied, and the worldwide distribution of institutions involved in the analysis of laser ranging data. The full list of members is given in Table 3.4-1.

Name	Institute/Country
Graham Appleby	NERC/United Kingdom
Richard Biancale	GRGS/France
Richard Eanes	CSR/USA
Ramesh Govind	AUSLIG/Australia
Rolf Koenig	GFZ/Germany
Hiroo Kunimori	CRL/Japan
Cinzia Luceri	ASI/Italy
Vladimir Mitrikas	MCC/Russia
Juergen Mueller	IAPG/Germany
Ron Noomen (coord.)	DEOS/Netherlands
Toshi Otsubo	CRL/Japan
Bernd Richter	BKG/Germany
Remko Scharroo	DEOS/Netherlands
Pete Shelus (dept. coord.)	CSR/USA
Tim Springer	AIUB/Switzerland
Mark Torrence	NASA/USA

Table 3.4-1. ILRS AWG members (status December 31, 1999).

ACTIVITIES IN 1999

The year 1999 has been very important for the AWG, since it saw the beginning of the efforts to coordinate the analyses and to come to a set of unified data analysis products. First of all, the membership of the working group was finalized. In the course of the year, e-mail discussions on various issues that face the ILRS in general and the AWG in particular were held, which led to a dedicated Working Group meeting during the Conference on Laser Radar Ranging and

Atmospheric Lidar Techniques in Florence, Italy, in September 1999. About half of the members of the AWG attended this meeting.

Here, a number of topics were discussed, such as analysis standards, products, formats and quality control. As for the use of analysis standards, it was decided to not so much prescribe but rather recommend a certain standard (typically, the IERS 1996 Conventions are most appropriate). In this way, analysts are encouraged to continuously improve their technique, strategy and models, stimulating a certain competition between contributors to see who is best in describing the physical reality of satellite and earth dynamics, whereas the strict prescription of a single standard would not encourage such progress. Analysis products that can be generated with the laser ranging technique are abundant, but it was decided to initiate the coordination and combination efforts with the fundamental products “station positions” (including site motions, observations allowing) and Earth orientation. In the future, other parameters (e.g. geocenter, temporal variations in the gravity field, ephemerides, lunar precession and nutation, etc.) may also be included. The group members present also decided to adopt the internationally well-established SINEX format for exchange of analysis results; in principle this format has all the elements that are necessary for providing full information on positioning and earth orientation solutions, and it is in principle open for new parameters. Finally, the problem of fast-turnaround quality control, in particular at various levels (on-site, analysis center, etc.) was discussed.

Most important, three pilot projects were initiated, each of them with the overall goal to improve the quality of SLR/LLR analysis results. They are:

- a project to unify the results of semi real-time quality control analyses of SLR observations on several satellites;
- a project aimed at the computation of station coordinates; and
- a project aimed at the computation of earth orientation parameters.

Each of these will be described in more detail below.

Pilot project 1: unification of fast-turnaround analysis results

At this moment, six different analysis institutions analyze SLR measurements on different targets on a routine basis. They are summarized in Table 3.4-2. The frequency of these analyses ranges from daily to weekly. The results are distributed in a rather uncoordinated way, i.e. each analysis center produces in some way or another an analysis report, which is made available to customers (stations, satellite managers) typically without comparison or checking with results obtained by others. This pilot project aims at two things: first, it intends to improve the interpretation of the “quality verdict” in the various analysis results. This can be achieved by interpreting time-series of range and/or time biases, instead of looking at absolute values. Ultimately, all individual analysis results should be merged into a single report, with a unique interpretation of the data problem(s) and the uncertainty of such an assessment. To make a first step, it was agreed that all groups should have their analysis results ready by Wednesday morning of each week.

Institute	Satellite						
	ERS-1	ERS-2	AJISAI	LAGEOS-1	LAGEOS-2	GPS-35	GPS-36
AIUB						+	+
CRL			+	+	+		
CSR				+	+		
DEOS	+	+		+	+		
MCC				+	+		
NERC				+	+		

Table 3.4-2. Overview of fast-turnaround SLR quality control analyses.

Pilot project 2: computation of station positions

The ILRS is tasked to coordinate the SLR/LLR analysis activities, stimulate a high quality of analysis results and develop an official ILRS product. The latter may pertain to various subjects: positioning/reference systems, earth orientation, geocenter, gravity field, tides, ephemerides, lunar precession and nutation, fundamental constants, etc. (cf. ILRS Terms Of Reference at:

<http://ilrs.gsfc.nasa.gov/termsref.html>

To make a start with this, two additional pilot projects were defined in Florence (September 1999): one on positioning and another one on Earth orientation, respectively. These pilot projects have a number of goals:

- to test the communication between the various analysis centers and data centers (aspects are transfer of solutions, use of and adherence to a data exchange format, meeting deadlines and adherence to the product definition);
- to stimulate and encourage individual analysis centers to improve the quality of analysis;
- to explain and minimize the discrepancies between different analysis results obtained by individual analysis centers;
- to develop an operational analysis procedure, including official ILRS products with maximum quality and meeting time constraints; and
- to promote the laser technique in general.

Since the initial goal was not so much absolute quality but more communication, formats and relative consistency, it was decided to limit the pilot project to a relatively small dataset of SLR observations: LAGEOS-1 data for a period of 28 days (i.e. September 5 until October 2, 1999, inclusive). To stimulate intellectual freedom of the analysts and prevent a mere repetition of each other's computations, no analysis standard was prescribed; people were encouraged to use the well-known IERS 1996 Conventions as a starting point. For a proper definition of parameters, it was decided to model the station motions according to the ITRF97 solution (and keep them fixed), and use the ITRF97 positions as *a priori* positions for the (solved-for) station coordinates. Finally, it was recognized that the LLR component could contribute to this pilot project only marginally, at least at this stage, so it was decided to focus on SLR first.

Pilot project 3: computation of earth orientation parameters

The third pilot project which was defined in Florence is on the computation of Earth orientation parameters, one of the traditional products of the laser ranging community. This project is very similar to the previous one on station positioning, in the sense that the goals, the proposed procedure and the test dataset are all more or less the same. This project, in particular, aimed at providing a (short) time-series of solutions for

1. the position of the pole as expressed in x and y coordinates,
2. the rotation of the earth as expressed by the UT1-UTC time difference. These parameters were to be provided at 3-day intervals. For more information, the reader is referred to the description of the project on station positioning.

Pilot projects "positioning" and "earth orientation:" results

The projects officially started directly after the Third General Assembly in Florence. The first activity was the preparation of a clear dataset of SLR observations to be used by all analysis centers. This dataset was available as of October 12 and was not screened for single outliers or bad passes, to reflect a semi real-time, operational situation as well as possible.

During the remainder of October and November, the Analysis Centers processed the measurements and submitted network solutions to the central archiving facility at NASA's Crustal Dynamics Data Information System (CDDIS). These first results highlighted quite a number of mainly format-related problems with the individual solutions, necessitating a second round of analysis for almost all contributions. During the final weeks of December and the first weeks of January 2000, the results were compared and/or combined by several institutes.

The results have been presented and discussed at an AWG workshop which was held in Frankfurt, on January 17-19, 2000. Although strictly beyond the time-span of this annual report, the results will be described here briefly.

Twelve analysis groups submitted solutions for the overall network of SLR stations, whereas 6 groups contributed to the comparison/combination. The specific contributors are listed in Table 3.4-3. NCL was not directly involved in the analysis of the pilot-study SLR measurements, but did make a significant contribution to the testing and comparison/combination of the solutions provided by others. As an example, Figure 3.4-1 shows the differences of a number of the submissions w.r.t. the ITRF97 solution, and also w.r.t. a weighted average. The results shown here have been computed by GRGS [Altamimi, 2000]; other analyses revealed similar results.

Institute	Station Positioning		Earth Orientation	
	Solution	Comparison	Solution	Comparison
ASI	Yes	Yes	Yes	Yes
AUSLIG	Yes	No	Yes	No
BKG	Yes	No	Yes	No
CRL	Yes	No	Yes	No
DGFI	Yes	Yes	Yes	No
GRGS	Yes	Yes	Yes	Yes
GSFC	Yes	Yes	Yes	No
IAA	Yes	Yes	Yes	No
IMVP	Yes	No	Yes	No
JCET	Yes	No	Yes	No
MCC	Yes	No	Yes	No
NCL	No	Yes	No	No
NERC	Yes	No	Yes	No

Table 3.4-3. Contributors to the ILRS pilot projects.

During the workshop, a number of problems were identified and discussed intensively. First of all, the definition and adherence to the SINEX format appeared not 100% clear to all groups involved. The discussion ended with a consensus on which elements to use and which not; the result is almost fully equivalent with the official description, but is more stringent on a small number of blocks: the FILE/COMMENT block is recommended (originally: optional), and the FILE/REFERENCE, SITE/ECCENTRICITY and SOLUTION/STATISTICS blocks are mandatory (original: mandatory for IGS only [2x] and optional).

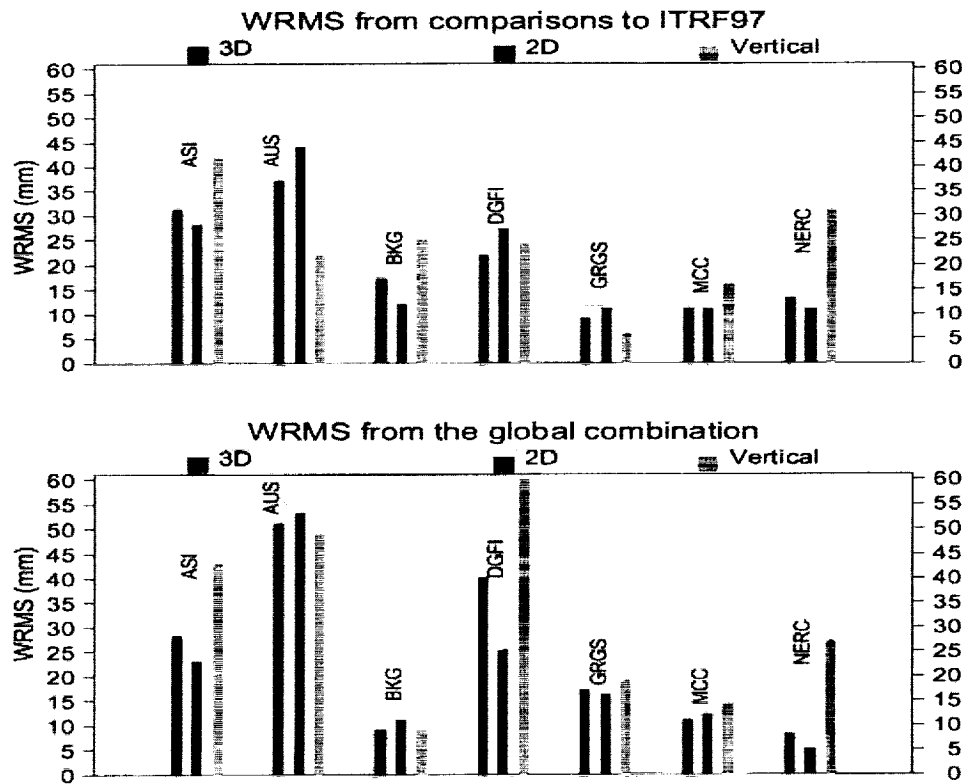

Figure 3.4-1. Comparison of initial results of the pilot projects on station positioning (Altamimi, 2000).

Another problem appeared to be the constraining of the individual network solutions: some of the solutions were overconstrained, providing various problems in the comparisons and combinations. It was decided to provide as little constraints as possible in future solutions, i.e. at least 1 m (10 m) for good (bad) stations and the equivalent of at least 1 m for polar motion and earth rotation.

Also, the definition of solve-for parameters turned out to cause some problems. Here the conclusion already achieved in Florence was emphasized once again: position solutions should refer to the official SLR reference point (i.e. the SLR marker) wherever possible, i.e. in situations for which an eccentricity vector is available the latter should be subtracted. In other cases the optical center of the telescope is the reference point for the solution. All solutions must be accompanied by the DOMES number to uniquely specify the location. In addition, it was decided to refer position solutions for both Zimmerwald and San Fernando (2 stations that have received new instrumentation recently) to the new telescope, at least when computed with observations from these new instruments.

In addition, the parameter to represent Earth rotation was discussed. In Florence, it was decided to use the UT1-UTC time difference for this purpose (in line with the demands for SLR submissions to IERS), although the length of day (LOD) may serve as an alternative. After lengthy debate, it was agreed to continue to use the UT1-UTC parameter, but on the understanding that satellite-based techniques cannot of course determine the true inertial UT1-UTC.

Finally, a proposal for the submission procedure (including testing and a naming convention) was discussed; this will be further developed during the coming months.

Most importantly, it was decided to continue the pilot project on harmonizing the quality control issues, and to combine the projects on station positioning and Earth orientation. To better define and assess the quality of the Earth orientation products, it was decided to repeat the analyses and solve for two time-series of EOPs, at 2-day and 3-day intervals respectively. As a consequence, the data period was extended from 28 days to 30 days.

In addition, 2 new pilot projects were proposed: one on satellite orbits (LAGEOS-1 initially), and another one on software benchmarking. These extensions are further discussed in the next section.

OUTLOOK FOR 2000 AND BEYOND

During the year 2000, the AWG will further develop the pilot project on station positioning and Earth orientation. In particular, it will first of all execute the conclusions and agreements from the workshop in Frankfurt and verify that these are implemented properly. This is expected to be finished in the middle of the year. In all likelihood, this will be followed up by the computation, using at least both LAGEOS satellites, of a relatively short (1 year) time-series of station positions and Earth orientation parameters, the consistency and quality of which will be assessed thoroughly. This will probably take place during the 2nd half of 2000, and is expected to result in an official ILRS product set. The AWG hopes to be in an operational scheme for product delivery as of January 1, 2001.

In addition, two new activities were initiated in Frankfurt:

1. A pilot project on the comparison/combination of satellite orbit solutions. This will be instrumental in improving and understanding the quality of the individual orbit solutions, where each analysis institute (again) is free to adopt its own preferred computation model, and also will stimulate improvement in the quality of solutions. Also, it will clearly show the capabilities and limitations of the most important element of this type of space geodetic work: the description of the orbit of the satellite. This project is likely to start in February, and results are expected in the middle of the year.
2. Benchmarking the software packages that are in use at the various analysis centers to try to reproduce results (orbits, parameters) that are obtained at different institutes, and strive for 100% agreement. Clearly, the participants will be obliged to adhere to a well-defined analysis standard. The overall intention of this project is to make sure that the various software packages that are in use at different analysis groups are free of errors; in addition, it will stimulate a better understanding of these programs. This pilot project is not expected to start until May of this year.

The results of these analyses and comparison/combination activities are likely to be reported and discussed during a number of informal meetings which will take place during 2000.

Finally, and very important for the community, the AWG strives for a better inclusion of the LLR component. This application of the laser technique is also capable of delivering solutions of the fundamental products, and it is the intention that these results will also be included in the ILRS comparison and combination efforts.

REFERENCES:

Altamimi, Z., "Analysis of station positions of the individual contributions within the ILRS pilot projects", paper presented at the ILRS AWG workshop, Frankfurt, Germany, January 17-19, 2000.

3.5 SIGNAL PROCESSING WORKING GROUP

Graham Appleby, *NERC Space Geodesy Facility*

CHARTER

The following Charter was created for the Signal Process Working Group (SPWG) by the ILRS Governing Board at The Hague ILRS Meeting of April 1999.

To determine accurate laser range Center-of-Mass corrections for a variety of satellites, appropriate to the major observing configurations.

In particular, to examine the corrections necessary to transform from raw range measurements to the center-of-mass of each satellite target, having regard to:

- array transfer function
- pulse-width and signal strength
- receiver characteristics (single photon, multi-photon, etc.)

To determine optimum processing strategies for each case.

- location measure in forming normal points (mean, mode, LEHM, something else)
- role of skewness and kurtosis measures
- filtering and trend-removal procedures

To propose procedures for recording and reporting the data required and used in determining and applying the corrections.

- data base used by Operational, Data and Analysis Centers
- station Information data base
- explicit data needed in ILRS NP and FR files
- format changes as appropriate

MEMBERSHIP

The following ILRS members are formally serving on the Working Group, but other members have contributed to the work being carried out:

Andrew Sinclair
John Luck
Peter Dunn
Thomas Zagwodski

Christopher Moore
Leigh Dahl
Reinhart Neubert
Toshimichi Otsubo

Georg Kirchner
Mike Selden
Stefan Riepl
Ulrich Schreiber

INTRODUCTION

The ILRS tracking network consists principally of three types of observing systems:

1. Systems employing multi-channel plate detectors (MCPs) and large numbers of return photons,
2. Systems employing single photon detectors (principally SPADs) and working close-to single-photon levels of return, and
3. Systems using SPADs but working at greater than single photon return levels. Modern SPADs employ a compensation circuit which can be tuned to the laser pulse-length [Kirchner *et al.*, 1996], and thus minimize energy-dependent time-walk effects.

Most of the systems in the network continue to produce high-precision laser range measurements, but this very diversity amongst the systems means that to realize the full potential accuracy in the measurements they have to be processed in a way commensurate with the differing observing characteristics. In particular it has been known for some time that the center of mass correction (CoM) to be applied to range measurements varies according to the type of system making the measurement [Otsubo *et al.*, 1999; Sinclair *et al.*, 1995]. For example, results to date suggest that measurements to the principal geodetic satellite LAGEOS made by a system working at single-photon return levels are on average some 10mm *long* on the same measurements made by an MCP system working at high return levels. If this effect is not taken into account when the data are analyzed, such a 'range bias' will be absorbed partly into station height determination, the quality of which will thus be degraded. For determination of scale, for which the SLR technique is particularly suited, such system-dependent differences will necessarily impact on the accuracy of a solution for GM for example. Advances in understanding these phenomena have been made over a number of years, most notably under the guidance of Andrew Sinclair within the EUROLAS network. This ILRS Working Group will build on that understanding.

During this first year, the strategy has been to understand the observing practices of some of the major systems in order to model those processes and derive appropriate CoM corrections. This has been carried out by involving them in the procedure and by analyzing full-rate satellite and calibration range data and statistical measures of system stability. At an early stage the Group agreed that the aim is not necessarily to recommend changes to current processing practices, as this could potentially create a discontinuity relative to older data sets from a given system.

SUMMARY OF WORK CARRIED OUT TO DATE

The Group has built on previous work in order to develop and test models to derive CoM corrections appropriate to various observing systems for a number of satellite arrays. In particular, the following have been considered:

- CoM corrections for LAGEOS and AJISAI for single-photon detector systems;
- Return energy effects for single-photon detectors;
- Data clipping effects;
- Statistics to monitor system stability;

- Planar array effects (e.g. GLONASS);
- TOPEX/POSEIDON array model.

Full details of these studies and results to date are presented by the originators on a web-site at:

<http://nercslr.nmt.ac.uk/sig/signature.html>

which is also linked-to in the Working Groups section of the official ILRS web-site. As an example of some of this work we present here in more detail some results of determinations of system-dependent center-of-mass (CoM) corrections for LAGEOS.

PRINCIPLES

To outline the principles of the ongoing work to derive tracking-system-dependent CoM corrections for the current constellation of laser-tracked satellites, we discuss the work being carried out for the primary geodetic satellite LAGEOS, and specifically for systems employing single-photon detectors. Our baseline assumption is that the pre-launch ground tests carried out for NASA on LAGEOS-2 are applicable only to systems using multi-photon detectors such as MCPs. The CoM correction determined from these tests was 251mm, the value currently in use by the analysis community to process range observations from the entire network.

We can begin to model the laser ranging process by convolving a (Gaussian) representation of the energy distribution of the laser pulse with an impulse function for the satellite reflector array (LRA). Previously both Degnan and Neubert have derived analytical impulse functions applicable to the spherical laser satellites and which give relative reflectivity as a function of distance from the surface of LAGEOS. We use here the impulse function of *Neubert* [1996]. The resulting distribution represents the probability density function (pdf) of the returning pulse from the satellite. We can then statistically sample from this pdf, modelling both the efficiency of the detector and the return energy (single or multi-photon), and further convolve with a model of the detector and timing system response. In practice, we use the range-distribution of measurements to a system's calibration target to represent the whole-system response to a flat target. The mean value of this response, computed according to the station's standard practice, is the system's origin. About this origin we then convolve the system response with the satellite impulse, obtaining a model of the expected distribution of range measurements obtained at single-photon return levels, as a function of distance from the surface of LAGEOS. If we now process this model to obtain the mean value, using the same rejection criteria as employed at the station when forming normal points, we obtain an estimate of the mean value of the CoM correction appropriate to that system.

This analysis has been carried out for two systems employing compensated SPADS, namely Herstmonceux, UK, and Koganei, Japan which use similar observing strategies. Herstmonceux works strictly at a single-photon level of return for all satellites, while Koganei attempts to keep the return rate reasonably low. The results of the analysis suggest that for the Herstmonceux system a CoM correction of 240 mm is appropriate, while for Koganei a value of 246 mm is indicated. Uncertainties in these values are estimated to be at a level of about ± 2 mm.

The distributions of range residuals in histogram form and our empirical models are shown in Figure 3.5-1. The long 'tail' in the model distributions is characteristic of the SPAD response.

Apparent in the distributions of range residuals are the different clipping levels employed by the systems which cause the truncation in the data with respect to the models.

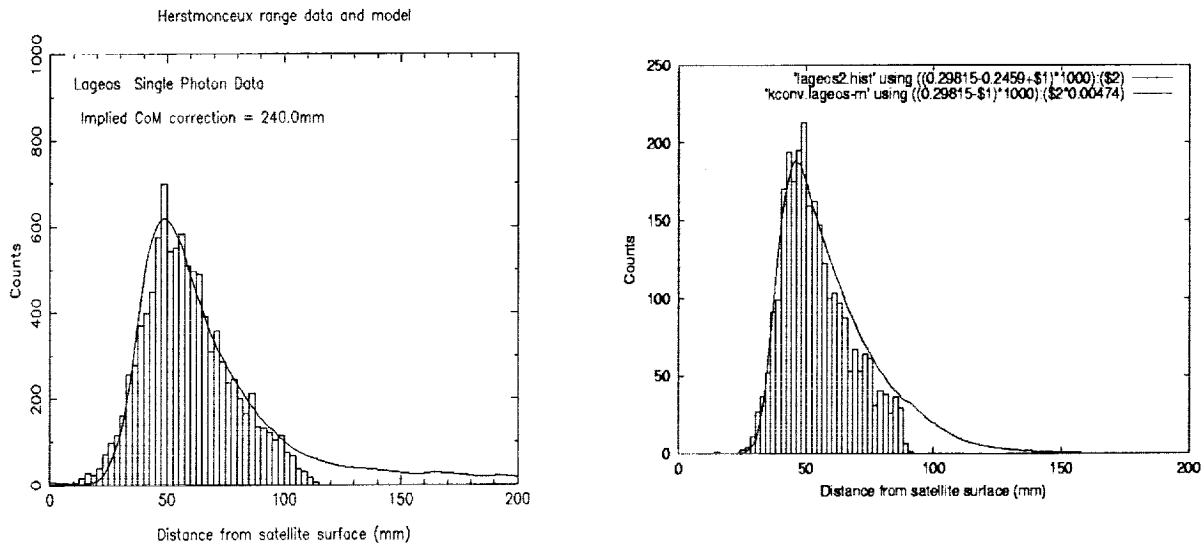

Figure 3.5-1. Comparison of data distribution with single-photon empirical model.

The same analysis has been carried out using calibration and LAGEOS range data from Graz, Austria. The system employs a compensated SPAD detector working at a multi-photon level of return, and employs a tighter clipping level than the other two stations. The result, as shown in Figure 3.5-2, is a more symmetrical distribution of range residuals, and as expected a poorer agreement of the single-photon model. More work is required to model properly this scenario, which suggests that a higher CoM value is appropriate.

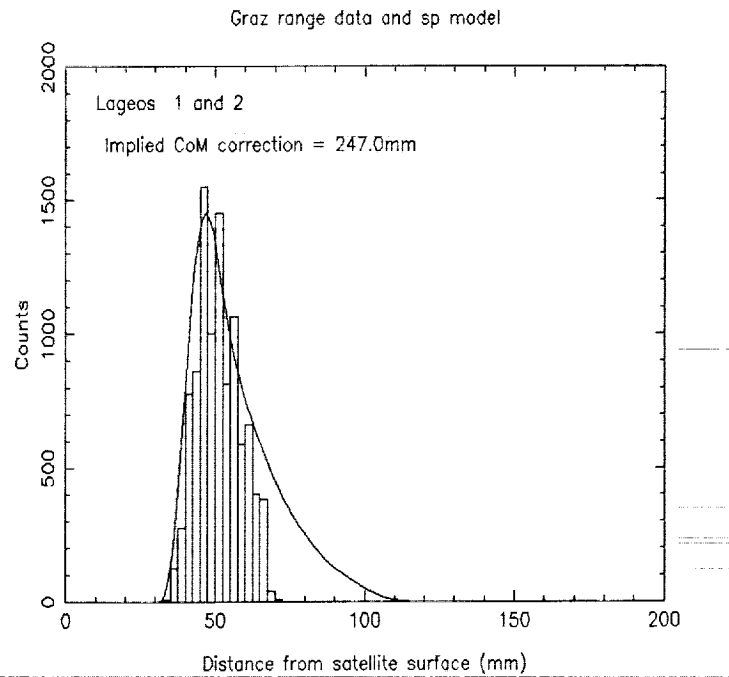

Figure 3.5-2. Comparison of Graz data distribution with single-photon empirical model.

PRESENTATION OF RESULTS.

Much of the work carried out by members of the Working Group was presented during the Colloquium on SLR-System Calibration Issues held in conjunction with the EOS/SPIE Symposium on Remote Sensing in Florence on September 20-24 1999. The following presentations were made:

- Mark Torrence: GM determination from multi-satellite analysis, and subsequent CoM deductions;
- Graham Appleby: Single photon model for LAGEOS;
- Reinhart Neubert: Data clipping and return energy effects + a model for the T/P array;
- Toshimichi Otsubo: AJISAI and GLONASS array functions and systematic effects;
- Van Husson: Signatures in GLONASS range data;
- Francois Barlier: Signatures in GLONASS range data;
- Andrew Sinclair: (*written report*) Statistics to measure systems' stability;
- Pippo Bianco: Probable observational evidence of LAGEOS rotation by MLRO observations;
- Stefan Riepl: Turbulence effects in SLR data.

Several of the presentations related to the signature effects of the large, planar arrays on the GLONASS spacecraft. Both Husson and Barlier presented observational evidence of systematic 'bias-type' effects in range residuals which increase as a function of satellite elevation. Otsubo presented a novel explanation for the observed effects, pointing out that SLR systems that work at high return levels will tend to measure from the edge of the array, whilst those working at low return levels will obtain reflections from all parts of the visible array. The systematic difference in the range measurements from these two types of system can amount to a relative 'bias' of up to 15cm, this mechanism possibly explaining the reported radial offset between laser range measurements and microwave-based orbits for the GLONASS satellites.

The last two presentations related to interesting spin-off applications from studies of satellite signature effects. The results presented by Bianco on work carried out with R. Devoti, V. Luceri and M. Seldon were obtained from analyses of range residuals from LAGEOS-2. The detection of signature-induced modulation of the residuals was used to infer a rotation rate of the satellite of about 11 seconds. This technique has been successfully employed by *Otsubo et al.* [2000] in the determination of a time-series of rotation rate values for the Japanese geodetic satellite AJISAI.

Riepl investigated the presence of range residuals 'ahead' of the modelled leading edge, which are evident in Figure 3.5-1 and more clearly seen in the corresponding results from AJISAI investigations. This slight misfit can be explained by scintillations in the received signal strength induced by atmospheric turbulence. Due to signal-strength statistics we cannot exclude the possibility that a SPAD-detector, operated on average at say 10% return rate, is detecting a few returns up to the level of 100 photons. Modelling this effect in conjunction with a time walk

model for the SPAD we find that the maximum peak shift of the resulting signature for AJISAI is about 1cm.

RECOMMENDATIONS

From discussions during the colloquium we make the following recommendations to other ILRS Working Groups:

- For some current satellites (including GLONASS, ETALON, Starlette), this Working Group needs better information on array characteristics and configuration (to Missions W/G);
- For all future missions, this Working Group must have access to pre-launch detailed information on composition and 3-D configuration of elements of the LRA. (to Missions W/G);
- That each Site/System Log File include 'standard practice' information (detector, return energy, data clipping) (to Networks and Engineering W/G)

FUTURE WORK

Detailed information on the location and characteristics of the elements of the GLONASS and ETALON LRA has been provided by the Russian Space Agency, thanks to the efforts of H. Kunimori on behalf of the Missions Working Group. This will enable more precise modelling work for these two classes of satellites.

Impulse functions for most of the spherical satellites will be computed by Neubert and Otsubo.

Models will be developed for multi-photon systems (MCP and SPAD).

REFERENCES

Kirchner, G, Koidl, F. Automatic SPAD time walk compensation, proc. Tenth Int. Workshop on Laser Ranging Instrumentation, pp 293-296. Fumin Y, Wanzhen, C, Eds, Shanghai, 1996.

Neubert, R. An analytical model of satellite signature effects, proc Ninth Int. Workshop on Laser Ranging Instrumentation, pp 82-91. Luck, J McK, ed, Canberra, 1996.

Otsubo, T., Amagai, J., Kunimori, H. The center-of-mass correction of the geodetic satellite AJISAI for single-photon laser ranging, IEEE Trans. on Geoscience and Remote Sensing, Vol 37, No. 4, pp 2011-2018, 1999.

Otsubo, T., Amagai, J., Kunimori, H, Elphick, M. Spin motion of AJISAI satellite derived from spectral analysis of laser ranging data. *Accepted for publication in IEEE Trans. on Geoscience and Remote Sensing*, 2000.

Sinclair, A.T, Neubert, R., Appleby, G.M. The LAGEOS center of mass correction for different detection techniques, proc Annual EUROLAS meeting, pp 31-36, Sinclair, A.T., ed, Royal Greenwich Observatory, 1995.

SECTION 4

NETWORK REPORTS

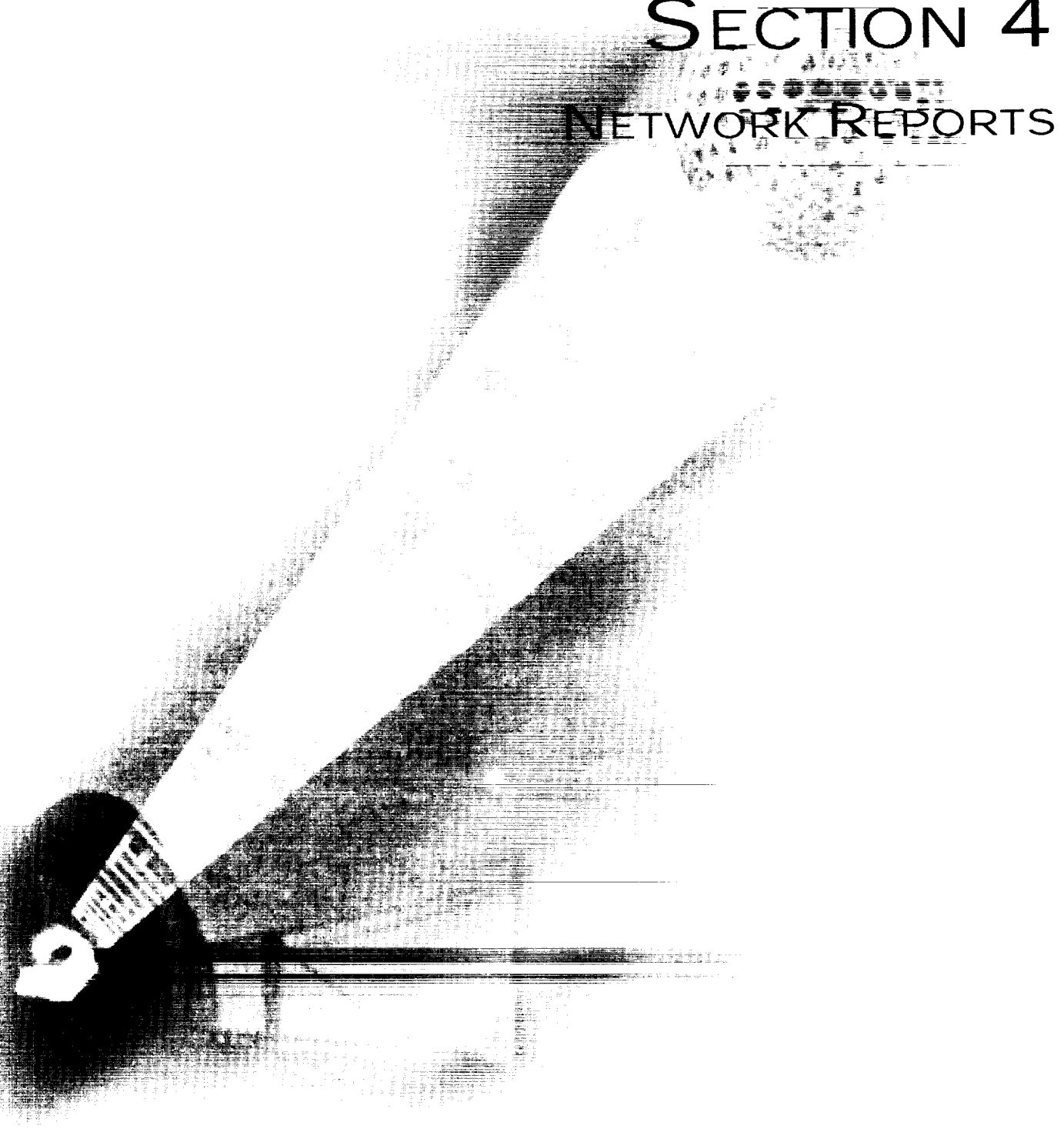

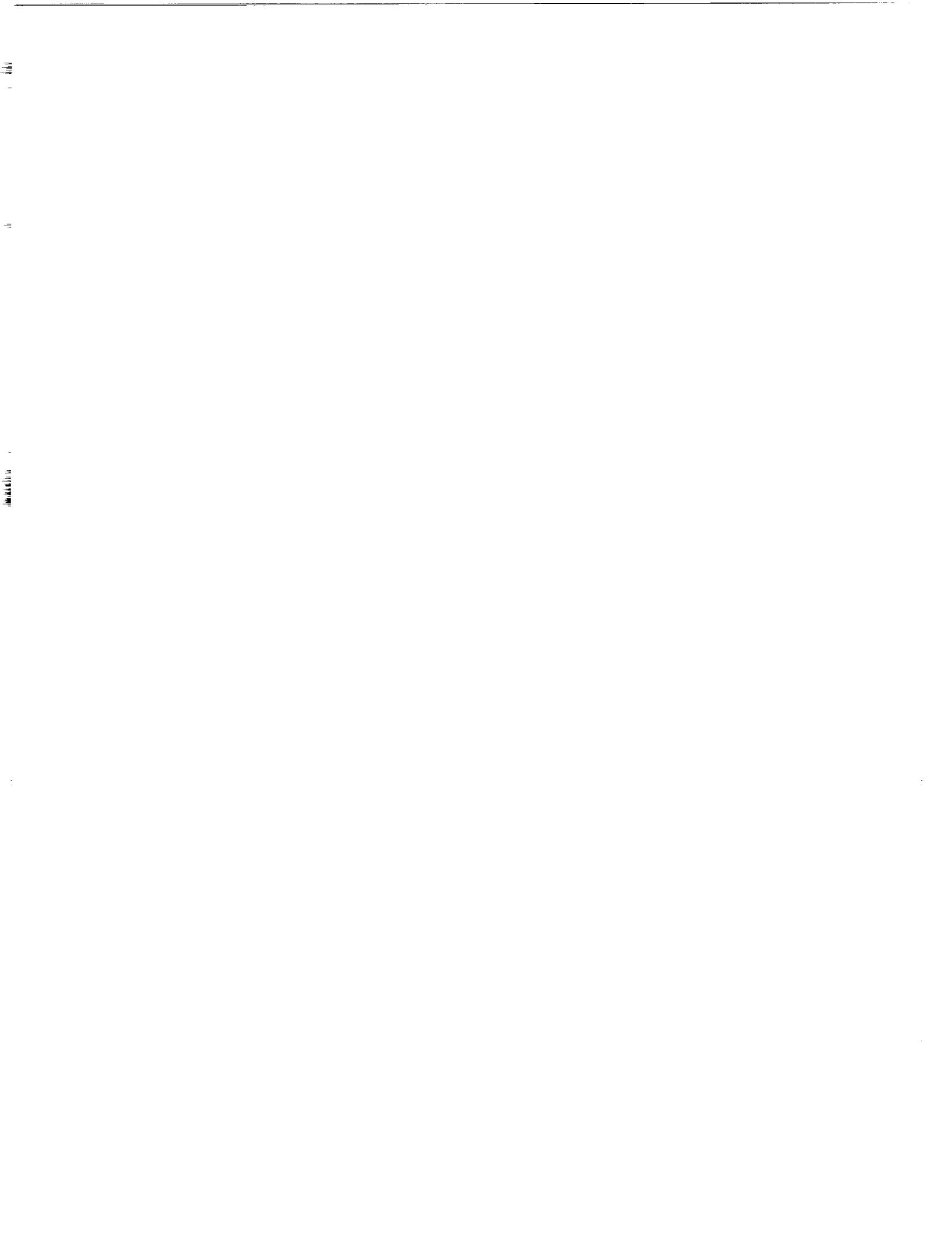

SECTION 4 - NETWORK REPORTS

The ILRS Global SLR Network is made up of three regional networks:

1. EUROLAS Network encompassing the European stations
2. NASA network encompassing North America, and some stations in South America, South Africa and the Pacific
3. Western Pacific Laser Tracking Network (WPLTN) encompassing Japan, China, Eastern Russia and Australia

There is some overlap among the regional networks due to cooperating agreements, equipment loans and historical operating arrangements.

4.1 EUROLAS NETWORK

George Kirchner, *Australian Academy of Sciences*

Graham Appleby, *NERC Space Geodesy Facility*

INTRODUCTION

EUROLAS, the European sub-network of the ILRS tracking network is a major contributor both to the global SLR tracking effort, and to the advancement of SLR technology and scientific value of the data. The eighteen stations that make up the sub-network (see Figure 4.1-1) have contributed during the period of this Report some 40% of the global tracking of all satellites and feature most of the different technologies in use globally for SLR work. Some systems use high-energy laser systems and MCP detectors, others use and continue to improve the Single Photon Avalanche Diodes that were developed within Europe, and some work strictly at the single-photon level of return. This disparate nature of the stations inevitably means that there exists a variation in tracking capabilities and quality across the sub-network. This variation in capability has, however, been recognized in recent years and some prioritization of targets has been decided upon at the EUROLAS level. For instance, the large and powerful systems in operation in Wettzell and Grasse are particularly suited to tracking high-altitude satellites such as the two GPS vehicles that are fitted with retro-reflectors. Other less capable systems concentrate on the equally important, but less demanding, low Earth satellites such as ERS-2 and TOPEX/POSEIDON. The very clustering of the EUROLAS stations has caused some criticism in the context of a global tracking network that is far from homogeneously distributed; the proposal that some systems be re-located to other less well-represented parts of the globe has frequently been voiced.

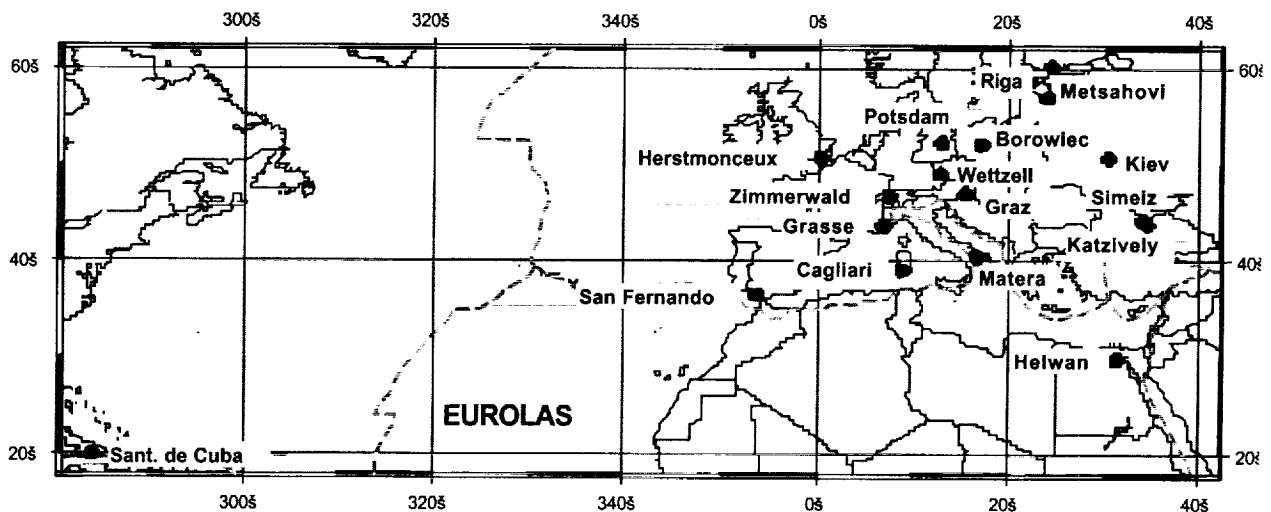

Figure 4.1-1 Eighteen Stations That Make Up the EUROLAS Sub-network

However, the clustering itself can also be regarded as a strength. Several altimeter missions such as the ERS satellites have benefited from concentrated SLR tracking in association with campaigns within Europe to calibrate their altimeters, and plans are in train similarly to calibrate the altimeter of the ESA mission ENVISAT due for launch in 2001. The close clustering of the stations also represents a unique opportunity to crosscheck the quality of each of the stations by carrying out analyses of simultaneous tracking data. The following sections of the EUROLAS report include a brief history of the origins of the Sub-network, an overview of its organization and services, and status reports from many of the stations themselves.

ORGANIZATION

The EUROLAS Consortium itself was founded in 1989 during the 7th International Workshop on Laser Ranging Instrumentation in Matera after a proposal discussed at a meeting of European laser station representatives in Paris earlier in the same year. The main purpose of the consortium originally was the representation of the European SLR groups and dedicated analysis centers towards international organizations like NASA, ESA, CSTG, Interkosmos, and the coordination of activities with respect to operations, priorities, distribution of tasks, etc. It was recognized that the European network of laser stations “serves as one continental observatory in support of programs of a global nature”, as can be read in the report about the Paris meeting.

The EUROLAS Board consists of the representatives of all member organizations and an elected Executive of at least a chairperson and a secretary. The Terms of Reference can be found e.g. at the EUROLAS Data Center (EDC) web site at:

<http://www.dgfi.badw-muenchen.de/edc/edc.html>

The contribution of the EUROLAS Data Center itself to the Annual Report can be found in the Data Center section of the Report and the NERC contribution below is a summary only of its report as an Associate Analysis Center.

<i>EUROLAS President: W. Gurtner</i>			
<i>EUROLAS Secretary: W. Seemueller</i>			
A. Banni	CAGLIARI	M. Medvedsky	KIEV
G. Bianco	MATERA	R. Neubert	POTSDAM (<i>Follower Ludwig Grunwaldt</i>)
J. del Pino	SANT. De CUBA	M. Paunonen	METSAHOVI
J. Garate	SAN FERNANDO	F. Pierron	GRASSE
W. Gurtner	ZIMMERWALD	S. Schillak	BOROWIEC
Y.E. Helali	HELWAN	W. Schlueter	WETTZELL (<i>Armin Broer/TIGO, U. Schreiber/WLRS</i>)
G. Kirchner	GRAZ	W. Seemueller	EDC
Y. Kokurin	KATZIVELY	L. Shtirberg	SIMEIZ
K. Lapushka	RIGA	R. Wood	HERSTMONCEUX
J.-F. Mangin	GRASSE/LLR		

Table 4.1-1 List of Delegates for the EUROLAS SLR Stations

JOINT EFFORTS OF THE NETWORK

Daily Quality Check

As an initiative some years ago the EUROLAS network agreed regularly to monitor the quality of LAGEOS and LAGEOS-II range data from the global network, and in particular to exploit the strength of the EUROLAS cluster of stations to form short-arc orbital improvements and thus potentially detect system bias at the 10mm level. This procedure was automated and implemented on a daily basis in a valuable collaboration between the UK NERC Space Geodesy Facility and the Department of Satellite Geodesy, Austrian Academy of Sciences, Graz. Each day presented on the NERC SGF website at:

<http://nercslr.nmt.ac.uk/>

are plots of normal-point range residuals from six-day orbital solutions for the two satellites for each station in the global network. Currently the post-solution residual RMS for these solutions is about 20mm, and the plots serve to provide a rapid check on the presence of outliers in the tracking data, as well as a quick daily check on network productivity. Then are determined which, if any, passes during the six days have been tracked simultaneously by more than two EUROLAS stations, and for those a short-arc orbital correction is computed. The residuals from this improved orbit give a good indication of the relative tracking quality of the stations, at a level of 10mm or so and again are presented daily in graphical form on the website.

Predictions and Time Bias Functions

The NERC Space Geodesy Facility computes two main prediction products, medium-term and daily. On a daily basis predictions are computed for most of the laser-tracked satellites including in addition the GLONASS satellites in support the IGEX-98 tracking campaign in a collaboration with the CODE, Berne, group. All the predictions are presented in the standard Inter-range Vector (IRV) format. Access information and the full list of satellites for which predictions are available is given on the official ILRS website. Time bias functions applicable to most of the available prediction sets are computed hourly using the latest observations from the network. Access to these functions is hourly via local ftp or daily by email from EDC.

Near-Realtime Status Exchange

In order to help exchange status information such as time biases between the European Laser stations in near realtime, a corresponding system has been defined and installed at a server in Zimmerwald. The basic principles are as follows:

Each participating laser station generates a one-line status file periodically (e.g. every 30 seconds) and sends it by ftp to the central server.

The server concatenates all available files into one resulting summary file, which is downloaded by the stations for display.

Each laser station may also upload a short message file to the server containing a message to be appended to the summary file for a maximum of 30 minutes.

The server also waits on a specific port for telnet connections and outputs the status file to these connections, too.

Example:

Herstmonceux	1998-11-30 09:55:57	LAGEOS2	CUR	345	DAILY	0.001
Potsdam	1998-11-30 09:55:23	LAGEOS2	CUR	221	CSR005	0.021
Zimmerwald	1998-11-30 09:55:26	LAGEOS2	LST	570	CSR005	0.023
Zimmerwald	1998-11-30 09:55:56	Ajisai	CUR	164	DAY001	-0.001

Currently 5 or 6 stations (Grasse SLR, Herstmonceux, Potsdam, Wettzell, Zimmerwald; Graz is working on the setup) routinely use this status exchange. It is thus possible to “learn” from a station the current time bias of a satellite, leading to an almost immediate acquisition, provided the two stations used the same IRV set for the predictions. Observers also like to see what’s currently happening at the other stations of the European network.

Future improvements will include a more direct information exchange using basic TCP/IP send and receive routines to avoid the large overhead of the ftp connections.

More information can be found in SLRMail 372, which can be downloaded from the EDC at:

<ftp://ftp.dgfi.badw-muenchen.de/pub/laser/messages/slrmail/slrmail.372>

Organization of Colloquium on SLR-Calibration Issues

This colloquium was organized by the Wettzell group and took place during the “Conference on Laser Radar Techniques” held in Florence, Italy, on September 23-24, 1999.

The largest remaining contribution to systematic error for range measurements to satellites and the Moon is related to the calibration process of the various ranging systems. Unlike in other space geodesy techniques we find a large variety in the laser ranging system design. Many systems have been developed independently over the last three decades, so that there is no standardization in methods or daily practice. This colloquium reviewed all the involved procedures and hardware arrangements in order to work out a standard set of recommendations for an optimized calibration process. It was specifically intended to keep a closed loop between the user of the data product and the data generating stations.

The colloquium was separated into two major sections, namely procedures and technology. The session about the procedures covered the areas analysis, calibration schemes, target design, local survey, data treatment and signal signatures. Especially the latter two subjects roused an extensive discussion, showing that these issues were by far not handled uniformly and had room for improvements at many stations. But also the subjects target design, local survey and calibration schemes stimulated a lively discussion and provided a good overview of the various practices in the community.

The second session on SLR technology dealt with the various critical components of an SLR system. All the major elements that influence the time of flight measurement were reviewed. In

fact it became clear that most stations are working within the same limits of accuracy. Unlike in the data treatment section there was relatively little room for improvement for most stations here. However some differences in operational practices for the calibration became apparent and were discussed.

A more complete summary of this colloquium is currently under preparation and will be made available to the community as an independent document.

Assistance and technical help between EUROLAS SLR stations

As examples of such activities, we mention here the supply of hardware on a long-term loan basis between various SLR stations. For the SLR station Riga, Peter Sperber has initiated this via EUROLAS recently, and the RIGA station is being supplied with CF discriminators, PMT's, and, hopefully, with some good working oscilloscopes from Graz and other stations. Metsahovi is about to start testing a microchannel plate detector borrowed from Graz and Graz is successfully using a Laser dye supplied from Potsdam.

SLR STATION REPORTS

GRASSE

LLR GRASSE/Satellite Laser Ranging

This report is about the SLR activities of the LLR station in Grasse; a dedicated report for the observations of the Moon appears in the LLR Section of the Annual Report.

The LLR station of Grasse (France) was fully operational in 1999 for the observations of high altitude satellites, although the priority remains on ranging of the lunar retroreflectors. Observations were regularly carried out on the two LAGEOS, GPS 35-36, Etalon and the GLONASS constellation. Many observations were taken during daytime, which is a distinctive mark of this facility. Altogether this yielded 4000 normal points for the two LAGEOS and about 3500 for the other targets, which is very satisfactory, given the scientific priority and the limited staff in charge of all the instrumental and logistical aspects and the observations. Several kinds of analyses (e.g. high precision orbitography, long period change in parameters of geophysical interest, long arc technique) are made by scientists of CERGA based on the laser data.

The station has been developed and optimized with the ranging on the Moon in mind and just recently adapted for the satellites. The width of the laser pulse, between 250 and 300 ps, is not optimal for the satellites and remains the major source of scatter in the raw data. In addition in the case of LAGEOS there are operational shortcomings due to its relatively short range meaning that no real-time calibration can be performed, which is the norm for the other distant targets.

Short-term plans are to keep on with this dual exploitation of the instrument and also to take advantage of the two tracking stations on the same site to improve knowledge of instrumental bias.

SLR GRASSE/CERGA: Fixed Station

The Grasse SLR system has operated continuously during 1999 without major failures. Observation priorities have been fixed in agreement with ILRS recommendations but excluding high passes (GPS, GLONASS); the nearby LLR station is tracking these satellites. A total of 2,755 passes (including 406 LAGEOS) have been observed, giving 51,000 Normal Points with a 2 mm RMS and a long term estimated stability of 13 mm (range bias adjustment with CSR solution). A very precise collocation experiment has been done between the fixed SLR and LLR station with common LAGEOS passes over several months; regular absolute gravimetric measurements are now being made at the site twice a year in order to establish correlations between potential ground motions observed with different techniques.

An important point to underline here is the recently improved efficiency of the operations due to the "Real Time Exchange" system used by most European stations; it is very helpful to fix the time biases from up-to-date results from other systems tracking the same spacecraft.

GRASSE/CERGA Ultra Mobile Laser system FTLRS

The year 1999 has been an important upgrade time for the Ultra Mobile French Transportable Laser Ranging System (FTLRS) in preparation for the 2000/2001 Jason calibration mission. In this timeframe, different technical problems had to be solved with the goal of reaching an accuracy of better than 1 cm. These include:

- Tests and measurements concerning time variations of the detector signal through the slip rings; replacement by a coaxial cable;
- Tuning the design of the laser to be operated in the green and with a pulse width of 35 ps;
- Tests of different SPAD detectors; installation in the very small FTLRS mount during October and November of a Time-Walk-Compensated SPAD (chip from Prague), with electronics especially designed by the Graz group.
- Due to the compact design of the FTLRS, the very serious problem of a high amount of backscattered light entering the detector during laser firing is being solved with an electro-optical liquid crystal shutter;
- Installation difficulties, such as thermal regulation of the shutter, free space for electronics inside the mount, etc.

The upgraded system should be ready for testing in early 2000. These include tests to replace the GPS-slaved Rubidium clock and collocation with the fixed SLR and LLR CERGA stations hopefully in spring/summer 2000.

SLR GRAZ

SLR Graz tracked about 4300 Passes during the year 1999; the list of satellites ranged from GFZ up to GPS 35/36; all satellites (including GPS) were tracked during day and night, 7 days per week. Besides this routine tracking, considerable work was invested into some upgrades, as follows.

Software:

Inclusion of a Real Time Scheduler, showing the list of actually running passes;

Implementation of Sun avoidance routines for the telescope daylight tracking;

In addition to the Automatic Range Gate and Automatic Tracking, Automatic Time Bias Calculations and Adaption (all for Real Time Tracking) were added.

Hardware:

Upgrade for Start Pulse detection: New Detection Scheme with improved stability;

Time and Standard Frequency now via an HP 58503A GPS Receiver (Graz Time Station has stopped this service);

Implementation of a new Start/Stop Pulse Distribution Unit, with six outputs for each channel, for Counter Cluster, tests etc. The unit has < 1 ps/ $^{\circ}$ C drift, adding < 1 ps RMS to the total jitter;

Two Dassault Event Timer Modules, plus 1 Clock Module (specs: < 2 ps RMS, 2.5 ps linearity) have been ordered (delivery expected spring 2000); hardware and software work is underway to build a complete new event timer system for the Graz SLR around these modules.

SLR HERSTMONCEUX, NERC Space Geodesy Facility, UK

The Herstmonceux site features the SLR single-photon system, an Ashtech GPS receiver contributing to IGS and a 3S Navigation GLONASS receiver all of which are operated on a continuous basis. SLR tracking of all satellites has continued day and night throughout the year. The single-shot precision achieved during calibration ranging is about 8mm, and that from ranging to LAGEOS is about 16mm. All ranging measurements are carried out at the single-photon level of return, and the long-term stability of the system appears to be excellent.

A C-SPAD detector was purchased late in 1998 and, after tests and re-adjustment at Graz to tune it to the laser pulse length, began operational use in 1999 March. Results of tests on the detector, together with extensive experiments to intercompare timers, were reported at the Europto meeting in Florence in September.

Trials using a calibration target attached to the end of the telescope have succeeded in overcoming SPAD gating problems and a fully engineered version is planned next year.

Replacement of the final mirror mount in the emitter coude train with a piezo-driven platform has enabled the correction of the beam alignment under computer control. Tests are currently underway to use TV systems to view both the beam and bright stars in daylight with the aim of developing algorithms for realtime corrections to telescope pointing and beam alignment (to compensate for daytime heating) with the aim of bringing daytime performance in line with that at night.

SAC - Astronomical Station of Cagliari, Italy

Instrumentation at the site includes the Fixed SLR Station and the GPS Permanent Station, with operational DGPS and Time Keeping/Synchronization using Standard Caesiums, GPS and Ajisai common-view. The SLR system includes a 10Hz Italian Quanta System Nd-YAG SFUR laser working at 532 nm with a 100ps pulse of energy 80mJ. The time interval counter is a HP-5370B and the detector is a Hamamatsu R943-02 PMT.

The SLR system achieves day and night tracking of Low Earth Satellites including Ajisai, Starlette and Topex/Poseidon, and in addition nighttime tracking of the LAGEOS and GLONASS satellites. The current single-shot calibration precision (1-sigma) is 250ps (35mm), with epoch accuracy of 1 μ sec.

Upgrades to be carried out in the near future include the replacement of the detector with a MCP-PMT Hamamatsu R5916U-50, replacement of the telescope encoders (22 bit = 0.5 arcsec) and the telescope motion gear (0.1-20 mrad/sec). The software will also be upgraded from the present C and DOS system to C++ under Linux.

Current research activities include co-location techniques; Geoid and local networks ties; and time synchronization.

SLR MATERA: SAO-1, MLRO

During 1999, the old SAO-1 SLR system, operational at the Center for Space Geodesy of the Italian Space Agency, Matera, Italy, observed the largest number of passes since its installation in 1984, a total of 1725 passes on 12 target satellites. This was the last fully operational year for SAO-1, which will soon be replaced by the Matera Laser Ranging Observatory (MLRO)

The development of the MLRO is now on its final phase. In 1999, the observatory building was completed, the dome was installed and, at the end of the year, the system was shipped from the USA to Matera. The system is expected to be fully operational by July 2000.

Based on a 1.5 m reflecting astronomical telescope, the MLRO is a highly evolved SLR/LLR observatory, featuring a few mm range precision on LAGEOS (<1 mm RMS on ground targets), two color capability (532 nm and 355 nm), MCP-PMT and streak camera echo detection, imaging devices, on-line documentation and high level of automation.



Figure 4.1-2 shows the 1.5 meter MLRO telescope through the slit of the 9.5 meter dome. The aircraft detection radar's white dome is visible on the roof of the old SLR system.

SLR METSAHOVI

The configuration of the Metsahovi SLR station is very much the same as that reported in the 11th laser workshop in 1998. Some small changes have however been made, including the addition of a laser preamplifier, the addition of a HP5370B for comparison with the Riga counter and alterations so that the start pulse is taken after the mode-locked oscillator. A Hamamatsu MCP detector has been received from Graz for tests; the mechanical installation is ready, but the necessary gating electronics are in process.

There have been many problems with the meteo barometer. The Ashtech Z18 has suddenly stopped working (as it did about one year ago), ceasing data on GPS and GLONASS. Also much time has been spent comparing the system counters in an attempt to find which one represents the best linear system.

SLR SAN FERNANDO

After the new dome was installed during the 4th quarter of 1998 the SLR instrument was placed in a new position, 35 cm over the old one. The 1st quarter of 1999 was spent working on hardware and software to minimize the noise and to improve the quality of the observations. A new computer was installed to control the telescope tracking, and the cables from the control system to the telescope were changed. The telescope mirrors were recoated, and tracking was resumed in mid-April. During the remaining nine months of the year, 1916 LEO passes and 428

LAGEOS passes were tracked, which for each is well over the full-year ILRS baseline goal. From the beginning of the tracking period efforts have continued to improve the quality of the work. A new, closer calibration target has been installed to minimize atmospheric refraction dependence. A C-SPAD detector is planned for installation during the spring of 2000.

SLR HELWAN

The Helwan site is an important station in the SLR Network; it is still the only SLR station on the African Continent. Since June 1998 the station has been in year-round operation. The station fulfilled the ILRS Performance Standard for LEO satellites in 1999, having tracked 1331 LEO passes.

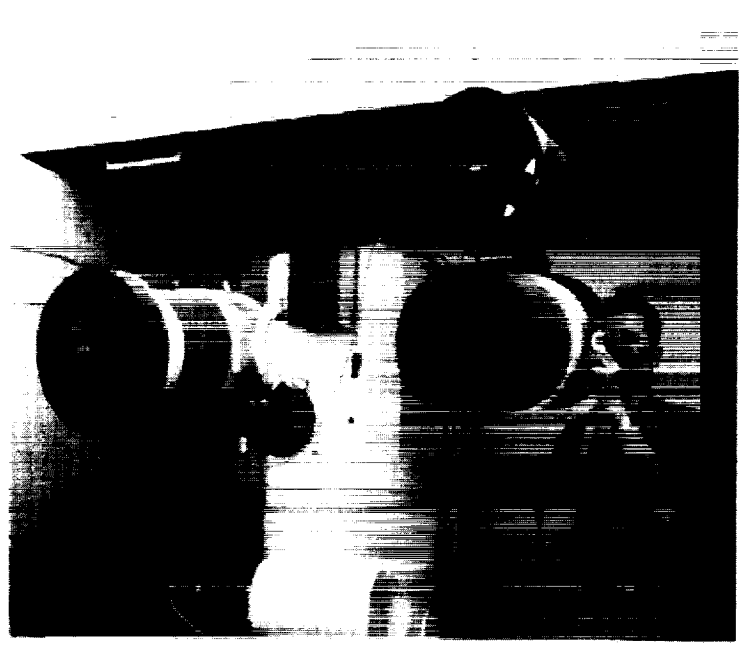

Figure 4.1-3 Helwan SLR Station

Several hardware upgrades have been carried out during the year, as follows.

A DIGIQUARTZ MET3 System has been installed. A Stanford SR620 Counter is now used for time interval measurement.

Time and frequency for the station originates from an HP58503B GPS Time and Frequency Receiver. A new Ground Target Calibration Scheme using a 2D hollow retroreflector has been installed.

The joint SLR Station Helwan is operated by NRIAG; National Research Institute of Astronomy and Geophysics, Cairo Helwan; Prof. Y.E. Helali/Prof. M.Y. Tawadros. Contact information is:

slregypt@intouch.com	Station;
nriag@frcu.eun.eg	CTU FNSPE Czech Techn. Univ. in Prague, Fac. of Nuclear Sciences and Physical Engineering;
novotny@troja.fjfi.cvut.cz	Assistant Prof. A. Novotny

SLR ZIMMERWALD

In 1995 the laser ranging system was dismantled and replaced by a new telescope and a new laser system. The 1-m telescope can be used for optical (CCD) astronomy, as well. The laser system is the first Titanium-Sapphire laser ever used for satellite tracking.

Since 1997 the new system has been operating on a routine basis. Two breaks of about two months were needed for recoating of the mirrors and for maintenance/repair of the laser system. Problem areas were found to be environmental problems (condensation), lifetime of the silver mirror coatings and of the pump diode of the laser oscillator, and high noise levels during daytime operation.

A high level of automation allows for a relatively short training period of the operators. Full remote control of the ranging system can be used for debugging and training purposes.

Next steps will be improvement of the ranging accuracy, use of the primary wavelength of the laser (846 nm) for ranging, and improvement of the automation.

SLR BOROWIEC

SLR Borowiec was operational 7 days per week throughout 1999 without important system modifications. It achieved returns during nighttime from all the satellites in the ILRS tracking program. The number of successful passes was the best in the history of the SLR station, with 1056 passes tracked during the year. The accuracy of the system remains on the same level as before, with a normal point precision of 6mm. In addition to the SLR system, the Borowiec site is a permanent IGS station (BOR1), operating a Turbo ROGUE SNR 8000 receiver and contributing hourly data to IGS. A new antenna was installed on June 1, 1999. The station also participated in the IGEX campaign, using a 3S Navigation GPS/GLONASS receiver, which continues in permanent operation. Full station parameters are on the Borowiec web page at:

<http://www.cbk.poznan.pl/~laser/bor1.html>

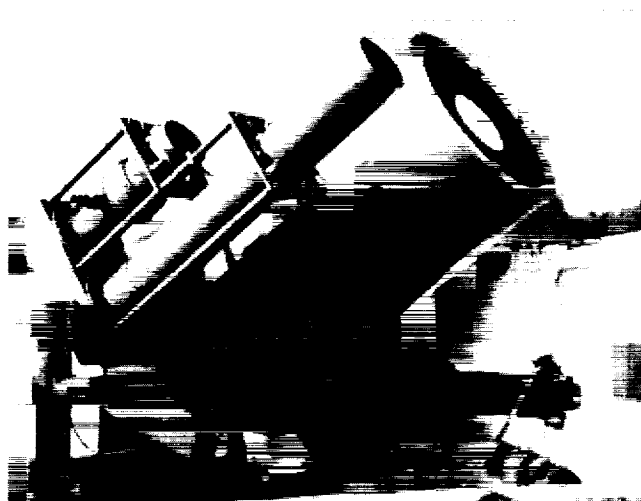

Figure 4.1-4 Borowiec SLR Station

Contact: Dr. Stanislaw Schillak: sch@cbk.poznan.pl

SLR POTSDSAM

SLR station Potsdam-2 (No.7836) has been operated routinely since 1993¹. Observations using this system will be continued until successful completion of the test phase of the new station, which will be sited about 300m away at the GFZ main building (Figure 4.1-5).

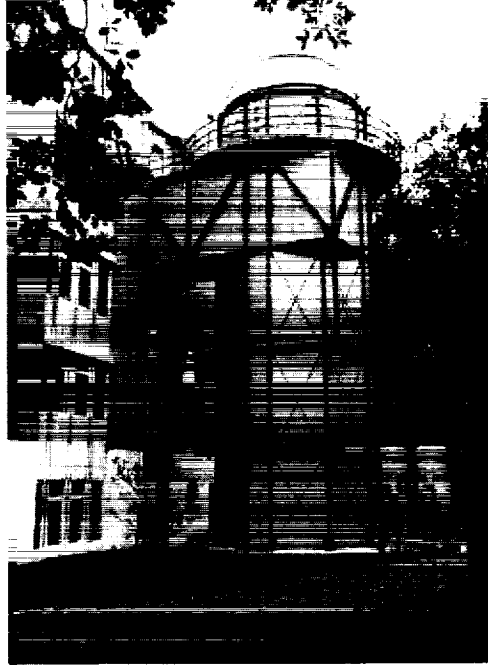

Figure 4.1-5 Building for the new SLR station at GFZ Potsdam. The laser transmitter is located inside the tower below the dome's platform whereas the control and measuring electronics is contained in a laboratory of the neighboring main building.

The new system is based on an unconventional bistatic telescope system², (Figure 4.1-6), and an actively mode-locked Nd-YAG laser. This laser produces pulses of 10 mJ in 30ps and can be switched between single pulse and semitrain operation under computer control.



Figure 4.1-6 Close up view of the telescopes in the status of assembling, without optics. Foreground: Transmitter (partially opened) without electronic unit. Background: Receiver, with on the right hand the electronic control unit (black box in the housing).

References

¹ <http://www.gfz-potsdam.de/pb1/SLR/slr.htm>

² Proc. Conf. on Laser Radar Techniques III, Florence, Sept.20-21, 1999

Wettzell Laser Ranging System

The main aim in 1999 was to build a new control system. Figure 4.1-7 shows the modular structure of the new control unit and the communication paths between the modules. The telescope control unit and the scheduler server are python programs based on a C-library whereas the measuring unit is a LabVIEW program (the front panel is shown in Figure 4.1-8). The communication is mainly based on TCP-IP connections between the computers and RS-232 interfaces between the measuring computer, the event timer and the radar, respectively. The new event timer consists of four Dassault timing modules and one clock module. The database is written in PostgreSQL. Here the IRV and timebias function parameters are saved together with a list of the actual satellites, information of the station and parameters of the measuring system. The tables in the analysis archives contain the history of the calibrations and the normal points of tracked passes.

The new control system will soon be ready to take over the routine ranging measurements.

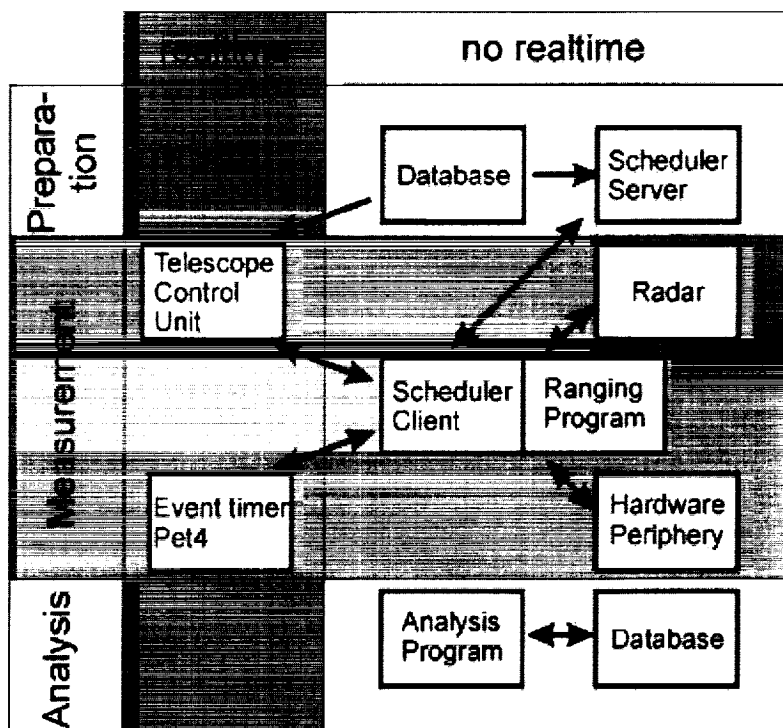

Figure 4.1-7 Scheme of the construction of the new control system. It has a modular structure that separates units needing real-time from the ones that don't depend on an exact timing. The arrows indicate the communication paths between the units.

Other activities underway concerned the timewalk effect in APD's. As reported at the Europto meeting in Florence in September, an investigation was carried out into an electronic compensation for the timewalk in APD's and into simulations to understand the sources of this effect.

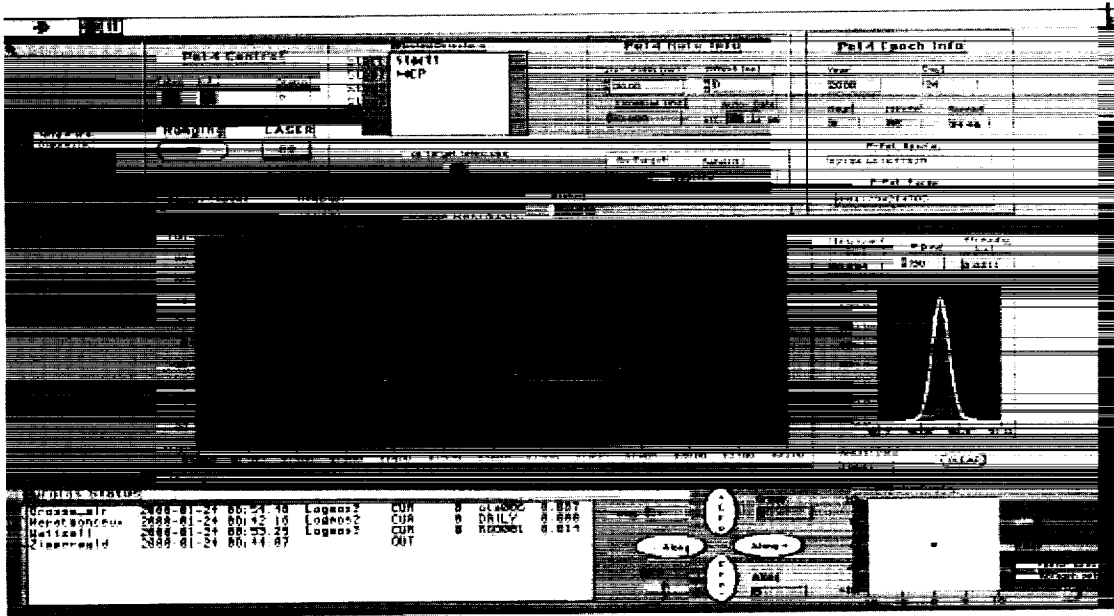

Figure 4.1-8 Front panel of the new control system at WLRs.

TIGO-SLR

The SLR system of TIGO, a Transportable Integrated Geodetic Observatory, is able to perform simultaneously two color laser ranging with an accuracy better than 1cm. The wavelength pair of 847nm/423.5nm has been chosen in order to obtain a large separation due to atmospheric dispersion.

The laser pulses are generated with a diode pumped Cr:LiSAF oscillator, amplified in a regenerative Ti:Sapphire amplifier and two Ti:Sapphire multipath amplifiers. The output energy is about 30mJ in each color at 10Hz repetition rate and pulse duration of 80ps. Figure 4.1-9 shows the laser setup in the container. Two color laser ranging should provide data to optimize atmospheric models.

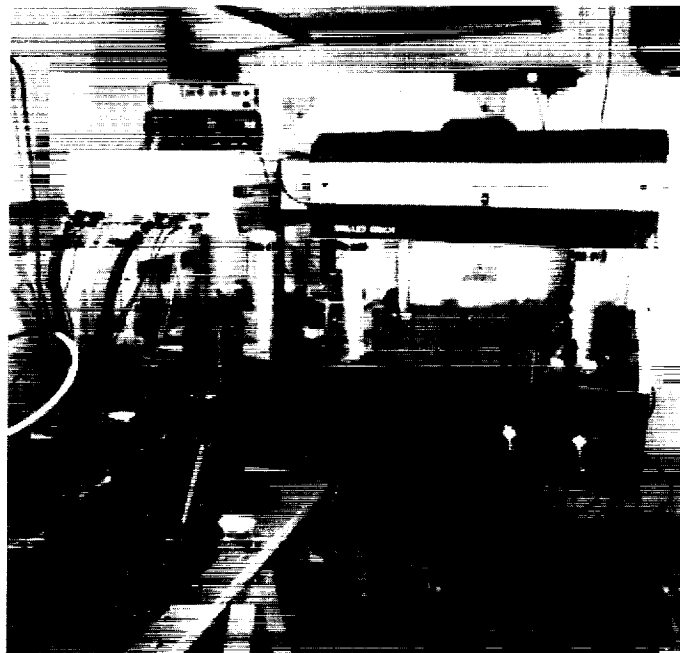

Figure 4.1-9 The Ti:Sapphire laser of the TIGO SLR system

The TIGO SLR was installed at Wettzell in 1998 (see Figure 4.1-10). After the first system tests of in 1998, a collocation was conducted with the WLRS. The results were presented at the 11th International Workshop on Laser Ranging, Deggendorf 1998. Since that time, major upgrades in the hardware and software have been conducted to achieve the reliability and stability which is needed to operate the system in the field. This includes: implementation of the PET4 timing system, replacement of the realtime transputer hardware, installation and adaptation of the "NEW WLRS" control software system and some improvements on the laser and the infrared detector. It is planned to have the system ready for work in summer 2000 and to again perform a collocation with WLRS. If this is successful TIGO will, in all probability, be shipped to Concepcion (Chile) at the end of this year and start its first operations at the beginning of the year 2001.

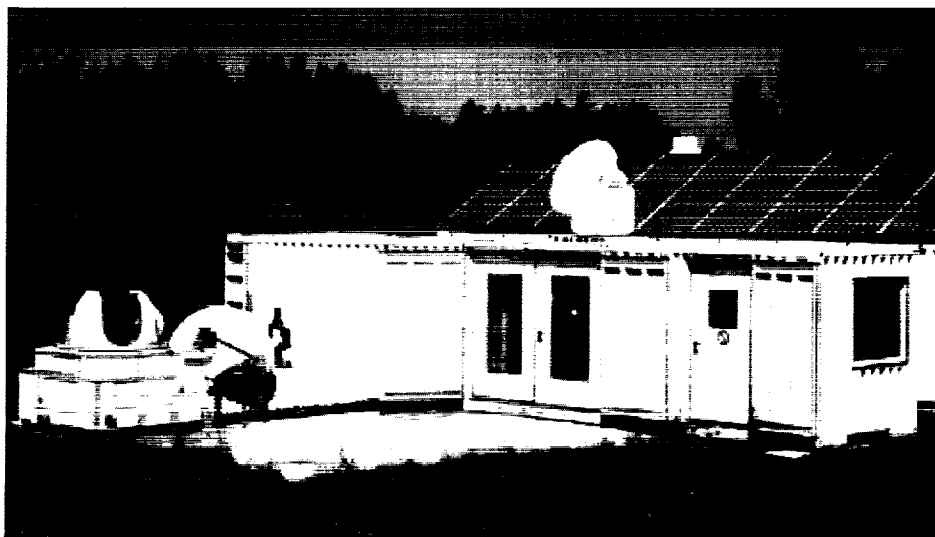

Figure 4.1-10 The SLR System of TIGO at the Wettzell site.

This Page Deliberately Left Blank

4.2 NASA NETWORK

David Carter, *National Aeronautics and Space Administration*

Scott Wetzel, *Honeywell Technology Solutions, Inc.*

The NASA Network includes nine NASA operated and partner operated stations covering North America, the west coast of South America, the Pacific, and Western Australia (see Figure 4.2-1). A new station is presently being setup in South Africa and discussions are underway to add another station in Argentina. NASA SLR operations are supported by Honeywell Technical Solutions, Inc (HTSI), formally AlliedSignal Technical Services, The University of Texas, the University of Hawaii and Universidad Nacional de San Agustin.

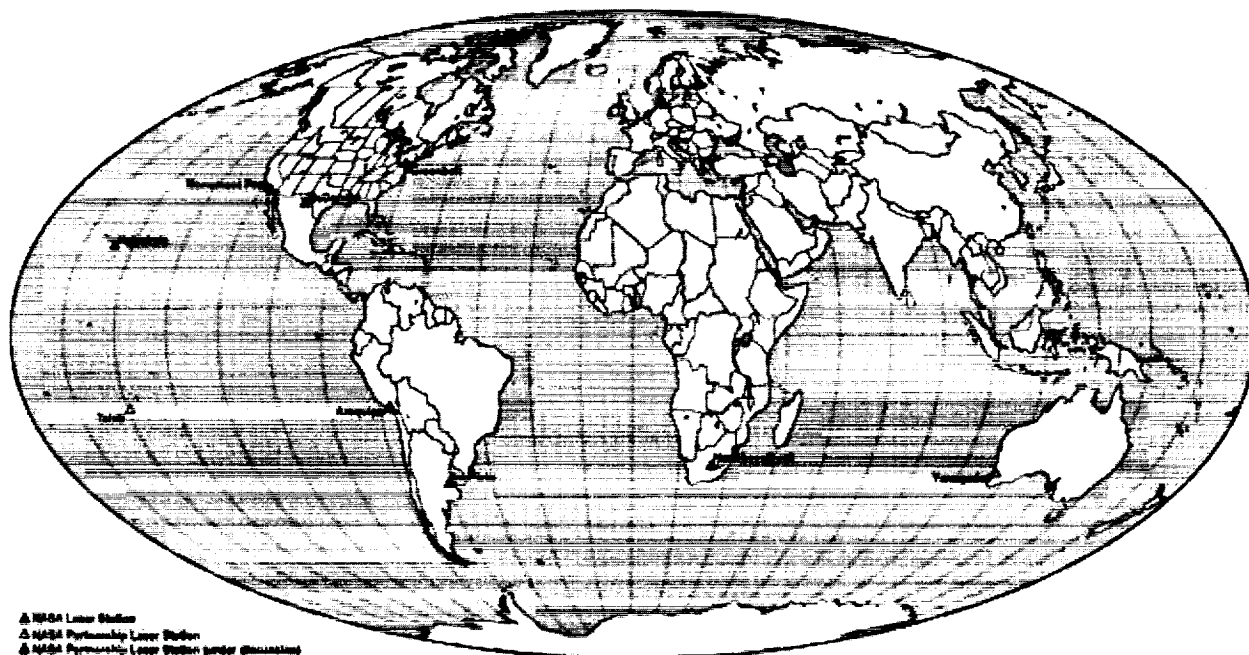

Figure 4.2-1 Map of NASA Network

Location	SLR System	Operating Agency
Monument Peak, California	MOBLAS-4	Mission Contractor (HTSI)
Greenbelt, Maryland	MOBLAS-7	Mission Contractor (HTSI)
Mount Haleakala, Maui, Hawaii	HOLLAS	University of Hawaii
Fort Davis, Texas	MLRS	University of Texas at Austin
Arequipa, Peru	TLRS-3	Universidad Nacional de San Agustin
Yarragadee, Australia	MOBLAS-5	Australian Surveying & Land Information Group
Tahiti, French Polynesia	MOBLAS-8	University of French Polynesia/CNES
Hartebeesthoek, South Africa	MOBLAS-6	National Research Foundation *
La Plata, Argentina	TLRS-4	La Plata University/CONAE **

* Setup underway; operations planned for late 2000. ** Discussions underway; operations planned for 2001.

Table 4.2-1 NASA Satellite Laser Ranging Network

BACKGROUND INFORMATION

Satellite Laser Ranging (SLR) is a fundamental measurement technique used by the NASA Space Geodesy Program to support both national and international programs in Earth dynamics, ocean and ice surface altimetry, navigation and positioning, and technology development. The SLR technique was first developed by NASA's GSFC in the early 1960's as a tool for precision orbit determination and validation of radio tracking techniques. Since 1969, NASA has built eight trailer-based Mobile Laser Ranging Stations (MOBLAS) that could be relocated to accommodate user needs. For the past fifteen years, five of the systems have remained in operation as fixed sites. The five remaining systems were built with a flexible configuration to adapt to new technologies and improvements to increase ranging capability.

During the 1980's, NASA developed four highly compact Transportable Laser Ranging Systems (TLRS). The TLRS systems were developed in response to the need of the geophysics community to obtain SLR data at remote sites, and to support programs such as the NASA Crustal Dynamics Project, Seasat, and the Working Group of European Geoscientists for the Establishment of Networks for Earthquake Research (WEGENER) Project. The University of Texas developed the first proof of concept system, TLRS-1, in 1980.

NASA also supported the development and operation of two Observatory SLR systems at the University of Texas and University of Hawaii. Both are high performance systems with the University of Texas system having lunar ranging capability in addition to SLR.

SITE DESCRIPTIONS

Sites have been chosen to enhance global coverage of the ILRS international network. Recently NASA efforts have been aimed at redressing the relative lack of SLR stations in the Southern Hemisphere.

Table 4.2-2 describes the location of the NASA systems in 1999 and other techniques that are supported at the SLR site location.

System	1999 Location	Yrs at location	Other Collocated Techniques
MOBLAS 4	Monument Peak, California	16	GPS, Gravity
MOBLAS 5	Yarragadee, Australia	20	GPS, Doris
MOBLAS 6 *	Greenbelt, Maryland	6	VLBI, GPS, PRARE
MOBLAS 7	Greenbelt, Maryland	18	VLBI, GPS, PRARE
MOBLAS 8	Tahiti, French Polynesia	1	GPS, DORIS, PRARE, Seismometer, Tide Gauge
TLRS-3	Arequipa, Peru	9	GPS, DORIS, Seismometer
TLRS-4 *	Greenbelt, Maryland	4	VLBI, GPS, PRARE
MLRS	Fort Davis, Texas	12	VLBI, GPS, Seismometer, Lunar Laser Ranging
HOLLAS	Mount Haleakala, Maui, Hawaii	23	GPS

* System was not operational awaiting relocation

Table 4.2-2 NASA Satellite Laser Ranging Network & Other Techniques

SYSTEM DESCRIPTION

Although there are some slight differences in hardware, the system configurations of the NASA Network stations are very similar (see Table 4.2-3).

	MOBLAS	TLRS	HOLLAS	MLRS
Mount Configuration	Az/EI	Az/ EI	Az/ EI	X-Y
Laser Type	Nd:YAG	Nd:YAG	Nd:YAG	YG402DP
Primary Wavelength	532 nm	532 nm	532 nm	532 nm
Pulse Energy	100 mJ	100 mJ	140 mJ	125 mJ
Repetition Rate	4 or 5 Hz	4 or 5 Hz	5 Hz	10 Hz
Receiver Aperture Dia.	30 in.	11 in.	16 in.	30 in.
Detector Type	MCP/PMT	MCP/PMT	MCP/PMT	MCP/PMT, SPAD
Timing Standard	GPS/Steered Rb.	Cesium	Cesium	Cesium

Table 4.2-3 System Configuration Information

MOBLAS SYSTEMS

The current MOBLAS system consists of a mobile optical mount (MOM) van and support van. All vans were originally designed to be transportable by trucks over improved roads to remote locations, but all are fixed in location. The MOM van is a semi-trailer designed to maintain all ranging and processing electronic equipment. The van measures 45 feet in length, 8 feet in overall width, and 13.3 feet in height. The interior of the van is divided into several compartments. The main compartments contain the tracking mount and optics, the laser head and power supply, and the control system and data processing instrumentation. The tracking mount and optics compartment has a retractable roof that is opened and closed by a motor-driven, chain-drive gear system. The laser has a horizontal firing angle zone of 300 degrees (360 degrees above a 20-degree elevation). The largest compartment is the instrumentation compartment which houses the data measurement system (DMS), servo control system (servo rack) portion of the tracking and mount control subsystem, interface to the antenna control console, and the meteorological display subsystem. The last compartment provides a work area and contains the air conditioning equipment.

The support van was originally provided to support MOBLAS systems when deployed to remote areas where required living quarters are not available. This van measures 40 feet in length, 8 feet in width, and 13.3 feet in height. It originally contained a sleeping area, kitchen, desk, and file cabinets for supply, maintenance, and administrative functions. The support van is now mainly used for supplies, maintenance, and administrative functions.

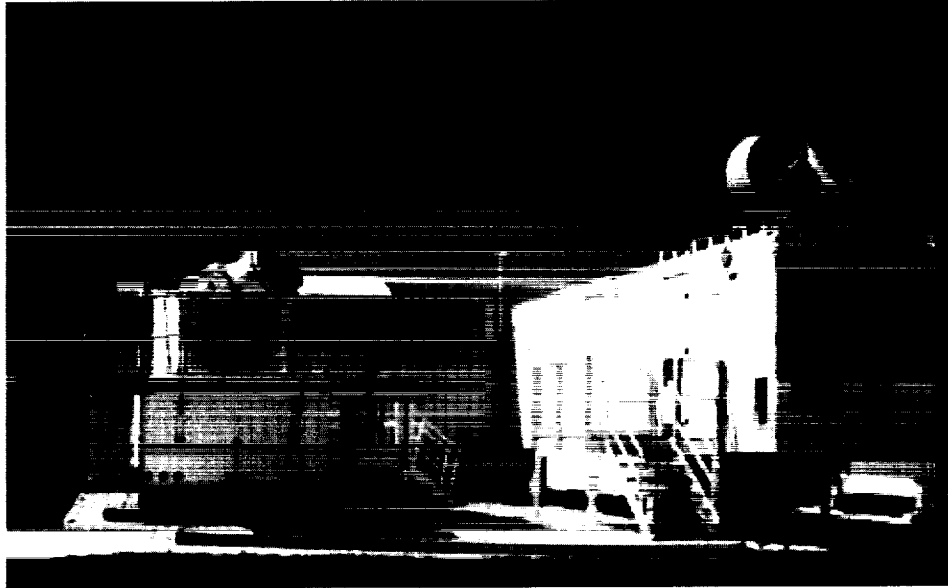

Figure 4.2-2 MOBLAS 7 at the GSFC in Greenbelt, Maryland

TLRS SYSTEMS

TLRS-3/4 is a highly mobile laser ranging system in that it can move from site to site and be set up in only a few days. Most of the system's electronic components are housed within a single mobile electronic equipment shelter. A second shelter is provided for personnel support. The power generator is positioned on a concrete pad nearby the electronic equipment shelter or flat bed trailer as required by site conditions.

Internally, the TLRS system is identical to the MOBLAS system in the type of laser, receiver, and timing subsystems. The major differences in the system to the MOBLAS are in the size of the trailer and mount system. Whereas the MOBLAS uses a larger 30 inch mount, the TLRS systems use an 11 inch telescope and utilize a shared transmit/receive path.

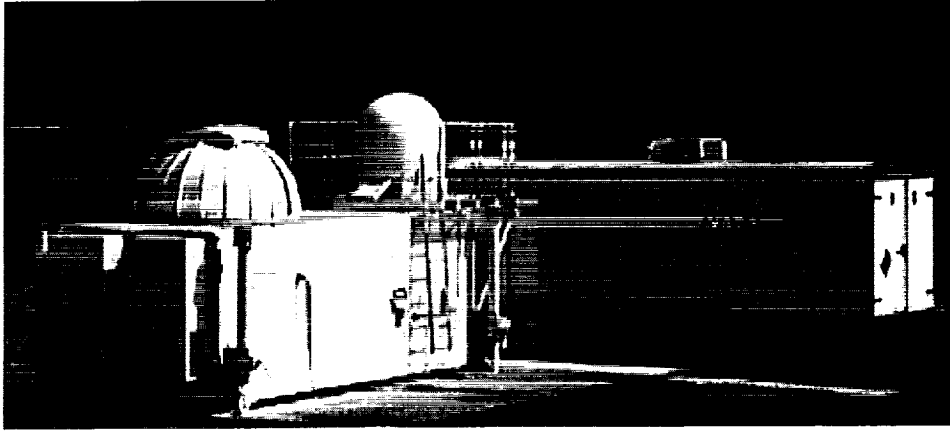

Figure 4.2-3 TLRS-4 located at the GSFC in Greenbelt, Maryland

MCDONALD LASER RANGING SYSTEM (MLRS)

The McDonald Observatory of the University of Texas is located in west Texas, near Fort Davis. After successful lunar laser ranging (LLR) experiments in March 1969, the 2.7-m Optical Observatory at McDonald became the premiere LLR station of the 1970's and early 1980's. It used a Korad ruby laser system and routinely produced LLR normal point data with an accuracy in the range 10-15 cm. After almost 16 years of continuous LLR operations at McDonald Observatory, the 2.7-m laser ranging system was de-commissioned and was superseded by a dedicated 0.76-m system. Using many of the plans and most of the equipment that was to be a part of a previously planned mobile LLR system, the McDonald Laser Ranging System (MLRS) was built. MLRS was built to range to artificial satellites as well as to the Moon. It was designed around a computer controlled 0.76-m x-y mounted Cassegrain/Coudé reflecting telescope and a short pulse, frequency doubled, 532-nm, Nd-YAG laser with appropriate computer, electronic, meteorological, and timing modules. The MLRS's epoch timing system makes all targets equivalent and crews routinely range to virtually all targets, from the closest of artificial satellites to the Moon, during a single shift.

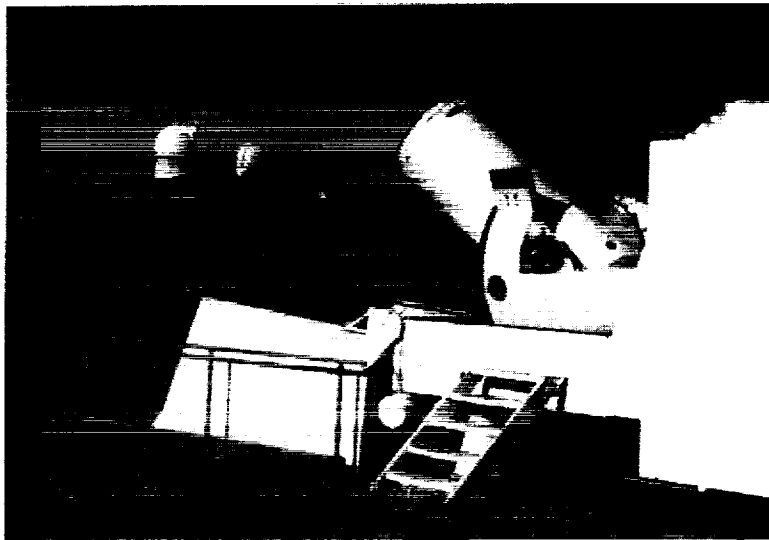

Figure 4.2-4 View of MLRS at Fort Davis, Texas

MT HALEAKALA LASER RANGING SYSTEM (HOLLAS)

HOLLAS is located at the 10,000 ft. summit of Mt. Haleakala on the island of Maui, Hawaii. The Observatory was developed by the University of Hawaii, Institute for Astronomy under contract from NASA GSFC. The Observatory was constructed in 1974 as a fixed Lunar Laser Ranging (LLR) station. During construction, provisions were made to accommodate SLR. LLR data was collected on a routine basis from 1985 until 1990. In 1990, LLR at the station was discontinued. Since then, activities have concentrated on SLR operations and improvements in SLR ranging capability.

The Observatory is constructed as a double domed building (see Figure 4.2-5) with the Lunar receive telescope in the 9 meter north dome. The laser transmit and satellite receive telescope is located in the 7 meter south dome. Connecting the domes is the computer control room and observer facilities. The Lunar receive telescope was mothballed in 1990, and has recently been moved to the island of O'ahu for use in a LIDAR system.

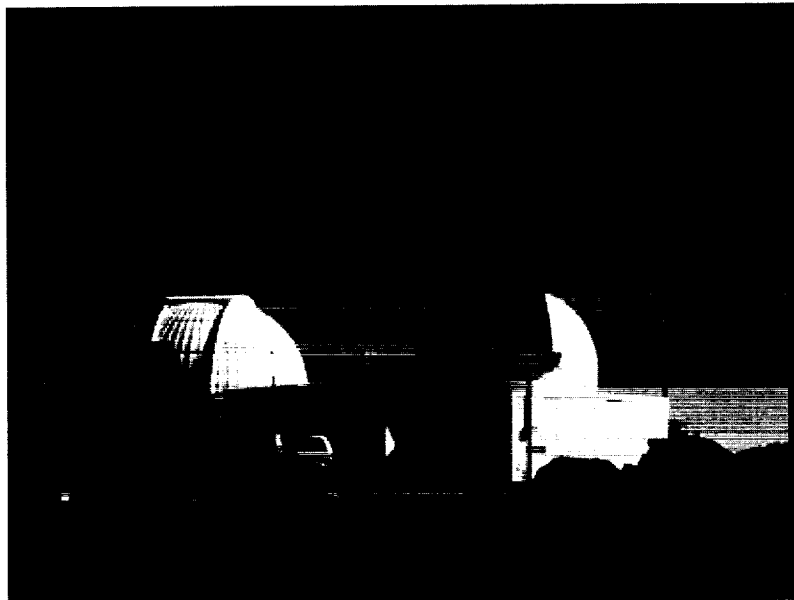

Figure 4.2-5 View of HOLLAS on Mt. Haleakala, Maui

SYSTEM UPGRADES

NASA has had a continuous program of system upgrades to improve system performance and increase automation while maintaining ranging capability to support the many programs that depend on SLR. HTSI has a small engineering group that supports network maintenance, upgrades, and new developments.

Over the last several years, aircraft detection radar, area viewing motion sensors, and cameras have been installed at each station to improved safety and security while at the same time permitting us to operate without an outside safety observer. Centralization of ranging and processing functions onto an upgraded computer platform has allowed us to standardized hardware and software, and to upgrade software and troubleshooting infrastructure. Many manual functions are being automated and the system hardware has been consolidated into a

single trailer. As a result of these modifications, operating staff has now been reduced from three people to one per shift. Additional amplification has been added to the receiver chain to enhance detection on low optical margin links to GPS, GLONASS, and Etalon. Recording of meteorological functions has been automated for both SLR and IGS needs, and station timing has been upgraded by replacing the cesium tubes and FTS 8400 GPS receivers systems with the True Time GPS Steered Rubidium and the CNS Totally Accurate Clock (TAC).

TLRS 3 and 4 have also been upgraded with many of the provisions above with the intent of making the TLRS and MOBLAS systems as identical as possible and to improve the TLRS system sustainability. The TLRS systems have been equipped with the same safety features, centralized computer control system, and enhanced receiver gain feature.

Both the MOBLAS and TLRS systems can now be operated 24 hours per day, 7 days per week with a staff of 4 people.

MCDONALD LASER RANGING SYSTEM (MLRS)

At MLRS, the aircraft avoidance radar has been installed along with the other security measures to permit single operator capability. Since April 1999, MLRS has been operating 24 hours per day, 7 days per week. Improved transmitter and receiver alignment facilities also make it easier for a single operator to maintain the system. A modification to the synchronization of the Transfer/Receive (T/R) switch has improved low satellite ranging. A new CNS Totally Accurate Clock (TAC) has also been installed.

HOLLAS SYSTEM

In mid-1999, an extensive SLR hardware and software upgrading program was initiated to improve system performance and to prepare for the surge of new satellites to be launched in 2000 – 2002. Every effort was made to keep data flowing at least on critical satellites as long as possible, but in October 1999 the system ceased operations and was placed in upgrade status. The DEC PDP-11/73 and RSX OS that had been running the station since 1980 was replaced by a Pentium based system that is running LynxOS, a real-time Unix. The new MOBLAS/TLRS controller software developed by NASA is being ported to the upgraded system, and the original telescope control electronics are being replaced by a custom two axis controller being developed by Willow Systems Ltd. of Albuquerque, New Mexico. The HP-UX system, which had been used to process data, has been replaced by a PC that is running Linux OS and processing software developed by HTSI. All systems are currently in place and are undergoing final integration and debugging. The upgraded system is scheduled to resume operations in July 2000.

Using radar data for aircraft spotting from the local Federal Aviation Authority, the station is also automating safety procedures in order to implement single operator operations. As with the other NASA stations, the original timing system has been replaced with a True Time GPS Steered Rubidium and the CNS Totally Accurate Clock (TAC).

NETWORK PERFORMANCE

The NASA network systems typically demonstrate 7- 10 mm single shot range noise and 2- 3 mm normal point precision. Accuracy is probably determined by the limits of the current refraction model (Marini and Murray, 1976). The MOBLAS and TLRS systems are calibrated using a close cornercube ground target. MLRS and HOLLAS use both ground targets and internal calibration. Network timing synchronization through GPS is typically better than 100 ns. Systems operate day and night. Table 3 tabulates recent network station performance in terms of passes acquired.

During the last year the stations at Mt. Haleakala and Arequipa have been undergoing major renovation in preparation for the surge of new satellite launches starting with CHAMP planned for spring of 2000.

<i>System</i>	<i>Low Satellite</i>	<i>LAGEOS</i>	<i>High Satellites</i>	<i>Moon</i>
Goddard Space Flight Center	3347	833	375	0
Monument Peak	5579	1525	896	0
Mt. Haleakala (HOLLAS)	403	130	138	0
Fort Davis (MLRS)	1755	497	396	166
Arequipa	1319	209	0	0
Tahiti	827	235	38	0
Yarragadee	3709	1052	1063	0

Table 4.2-4 Passes Acquired by the NASA SLR Network in 1999

DATA OPERATIONS

The NASA Operations Center run by HTSI receives the normal points and full rate data from the NASA Network Stations by Internet. Data from the remaining ILRS stations are accessed through the CDDIS or are sent in to the Operations Center directly by the stations by FTP. Data from MOBLAS-4, MOBLAS-7, HOLLAS, and MLRS is received on an hourly basis. The data from the other stations are received daily or sub-daily at varying intervals. Normal point data is checked for format and integrity. Normal point and full rate data are transmitted to the CDDIS once per day, where it is readily available to the analysis centers and the science community. HTSI generates predictions for all ILRS satellites on a as needed basis nominally in weekly installments. These predictions are transferred to the CDDIS, the EUROLAS Data Center (EDC), and other direct methods for access by the global SLR community.

PARTNERSHIP PROGRAM

One of the key elements of the NASA SLR program is the establishment of overseas partnerships to improve the global distribution of SLR stations. Under these partnerships, NASA provides the SLR system, training, engineering support, and spare parts to maintain operations. The host country provides the site, local infrastructure, and the operating crew. NASA has successfully partnered with the Australian Surveying & Land Information Group (AUSLIG)

(MOBLAS-5) in Yarragadee, Australia and the University of French Polynesia/CNES (MOBLAS-8) in Tahiti, French Polynesia.

NASA and the South African National Research Foundation have signed a Memorandum of Understanding for the transfer of MOBLAS-6 to the Hartelbeesthoek Radio Astronomical Observatory in South Africa. The Observatory also has VLBI, GPS, DORIS, and PRARE systems. The South African station manager and senior observer were trained at NASA Goddard Space Flight Center in late 1999. Shipment of the system is scheduled for May 2000, with operations planned for mid to late 2000.

Finally, NASA is currently discussing a partnership agreement with the University of La Plata and Comisión Nacional de Actividades Espaciales CONAE in Argentina for the operation of TLRs-4. The tentative site is the University's Radio Observatory outside of La Plata.

SLR 2000

Progress on NASA's automated and eyesafe SLR2000 system continued during 1999. Funding for the SLR2000 program began in August 1997. The first year was spent developing "enabling technologies" for the system, i.e. new prototype components without which the system could not be built. This included a 2 kHz microlaser transmitter, a quadrant microchannel plate photomultiplier (QMCP/PMT), a "smart" meteorological station, and kHz rate range receiver. The second year concentrated on testing/modifying the prototype components in parallel with generating the design/specifications for other major subsystems such as the facility and dome, arcsecond precision tracking mount, telescope, and optical transceiver. During the current fiscal year, we procured the shelter and 3-meter auto-tracking dome (see Figure 4.2-6), developed the prototype tracking mount at Xyber Corporation in Florida, and fabricated the off-axis 40 cm telescope at Orbital Sciences Corporation (OSC). An isometric drawing of the tracking mount and telescope is shown in Figure 4.2-7. A stainless steel riser will serve as the interface between the tracking mount and the internal concrete monument. The optical transceiver, which is also rigidly mounted to the riser in order to maintain boresight stability with the tracking mount optical telescope, consists of the microlaser transmitter, QMCP/PMT, CCD star calibration camera, spatial and spectral filters, passive transmit/receive switch, and all interface optics with the optical telescope. Factory and field tests of the telescope and tracking mount are scheduled for late Spring/Summer of 2000. Final assembly of the total system is scheduled for completion by Fall 2001 followed by a year of field testing with replication of additional units beginning in 2003.

For more detailed information on the SLR2000 system, please visit the SLR2000 Home Page at:

http://cddisa.gsfc.nasa.gov/920_3/slr2000/slr2000.html

System photos, specifications, and all recent technical articles on the SLR2000 system presented at international conferences are available online in their entirety and are accessible via the aforementioned web site.

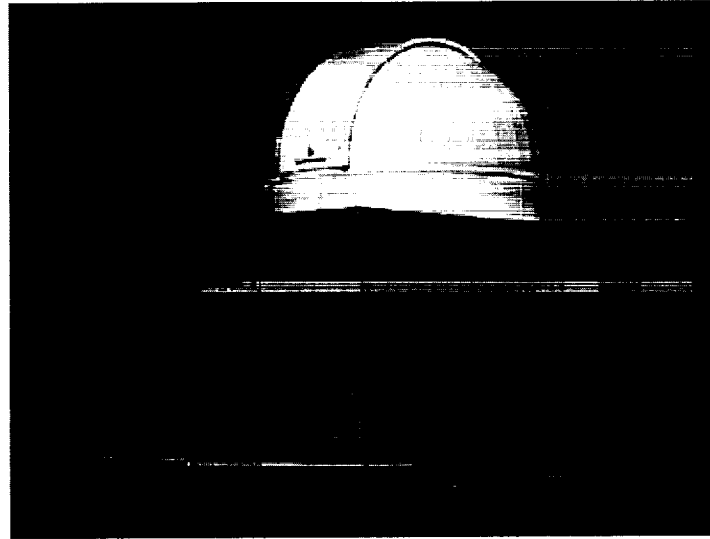

Figure 4.2-6a Exterior view of SLR2000 facility



Figure 4.2-6b Interior with Central Monument

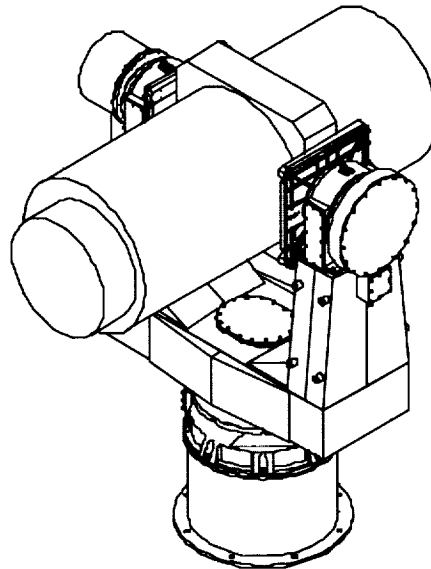

Figure 4.2-7 Isometric view of the SLR2000 tracking mount and 40 cm off-axis telescope.

4.3 WESTERN PACIFIC LASER TRACKING NETWORK (WPLTN)

Hiroo Kunimori, *Communications Research Laboratories*

John Luck, *Australian Surveying and Land Information Group*

4.3.1 INTRODUCTION

The WPLTN was established on 11 November 1994 during the Ninth International Workshop on Laser Ranging Instrumentation in Canberra (WPLS, 1994). Its Executive Committee initially consisted of two representatives each from Russia, China, Japan and Australia, to which have been added one each from Saudi Arabia and India. The most recent Plenary Assembly and Executive meeting were held in the week of 20-25 September 1998 during the 11th International Workshop on Laser Ranging in Deggendorf, Germany. WPLTN has had a symbiotic role in the establishment of the Keystone Project in Japan; it has provided financial support to the Russian R&D Institute for Precision Instrument Engineering (IPIE, formerly RISDE) and Mission Control Center, Moscow; it has significantly upgraded the Changchun station, China; it has provided support to restore the Saudi Arabian Laser Ranging Observatory (SALRO), Riyadh; it has organized SLR campaigns in support of the Regional Geodetic Network of the Permanent Committee on GIS Infrastructure for Asia and the Pacific; and it launched its own satellite WESTPAC on 10 July 1998. The function statement for WPLTN is given at:

<http://www.auslig.gov.au/geodesy/slr/wpltn/mission.htm>

and details of the WESTPAC satellite are linked through

<http://ilrs.gsfc.nasa.gov/westpac.html>

Separate reports for the Russian, Chinese and Australian sub-networks are given below.

STATION STATUS AND PERFORMANCE

The Chinese stations continue to improve greatly in their productivity. The four KeyStone Project stations in Japan have improved productivity considerably since October 1999, and their quality is excellent, although it is believed that Tateyama and Miura will close at the end of June 2000. Simosato is once again very productive. Russia is building two new stations. The Australian stations continue to perform well in all aspects. SALRO is undergoing extensive repairs as resources permit. Figure 4.3.1-1 illustrates productivity at the stations in 1999. Data quality varies, as seen in the ILRS Quarterly Global Performance Report Cards.

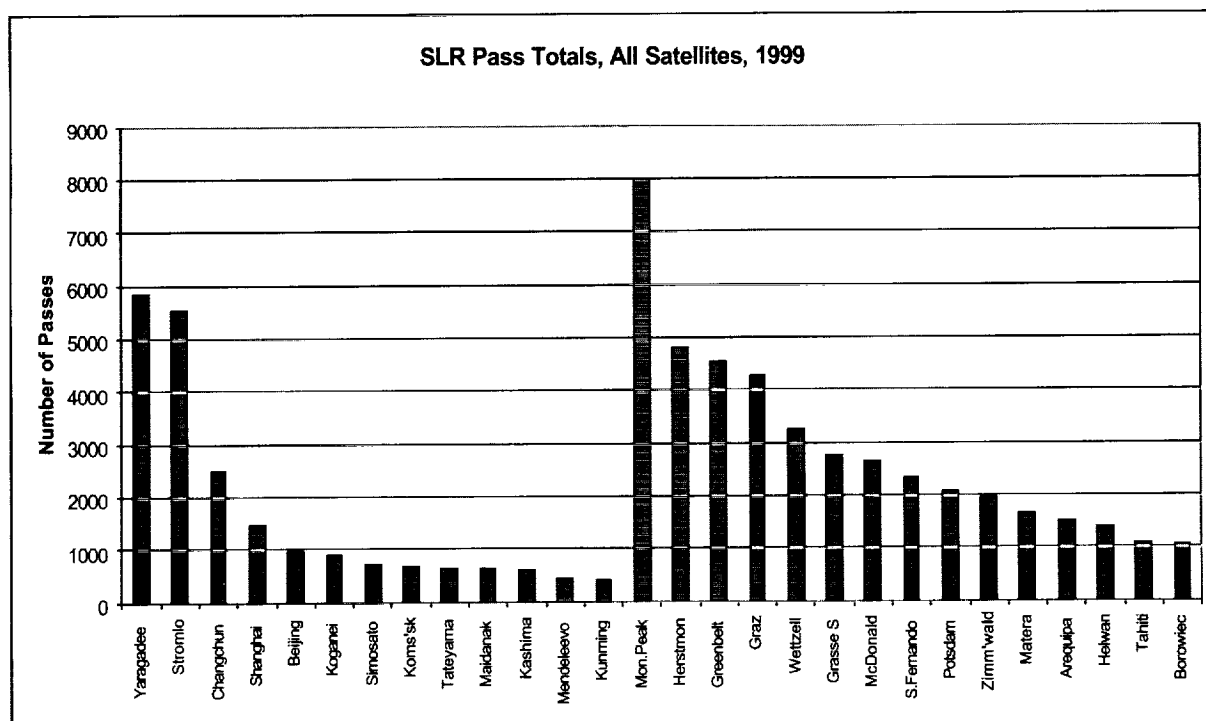

Figure 4.3.1-1 Passes in 1999, all satellites - WPLTN stations on Left, Others on Right

CAMPAIGNS

WPLTN received ILRS support for a campaign to track ETALON 1&2 during November 1999, as part of the Asia-Pacific Regional Geodetic Project APRGP'99, the latest in a series of annual projects starting in 1997 (see e.g. Luton et al, 1999). The next one is planned for October 2000. It resulted in significantly increased tracking on these targets, as shown in Table 4.3.1-1.

Period	Average Number of Passes tracked per Week (CDDIS Reports)			
	Etalon 1	Etalon 2	ET1 + ET2	Westpac
13 weeks before campaign	15.5	15.4	30.8	25.2
Campaign (5 weeks)	28.6	37.2	65.8	31.0
11 weeks after campaign	16.6	14.3	30.9	22.5

Table 4.3.1-1 ETALON Tracking rates before, during and after the November 1999 campaign.

The WESTPAC satellite continues to be tracked in quasi-campaign mode by the ILRS network. Its 1999 productivity is shown in Figure 4.3.1-2. 1418 passes were taken, on average, 27.3 passes being acquired per week

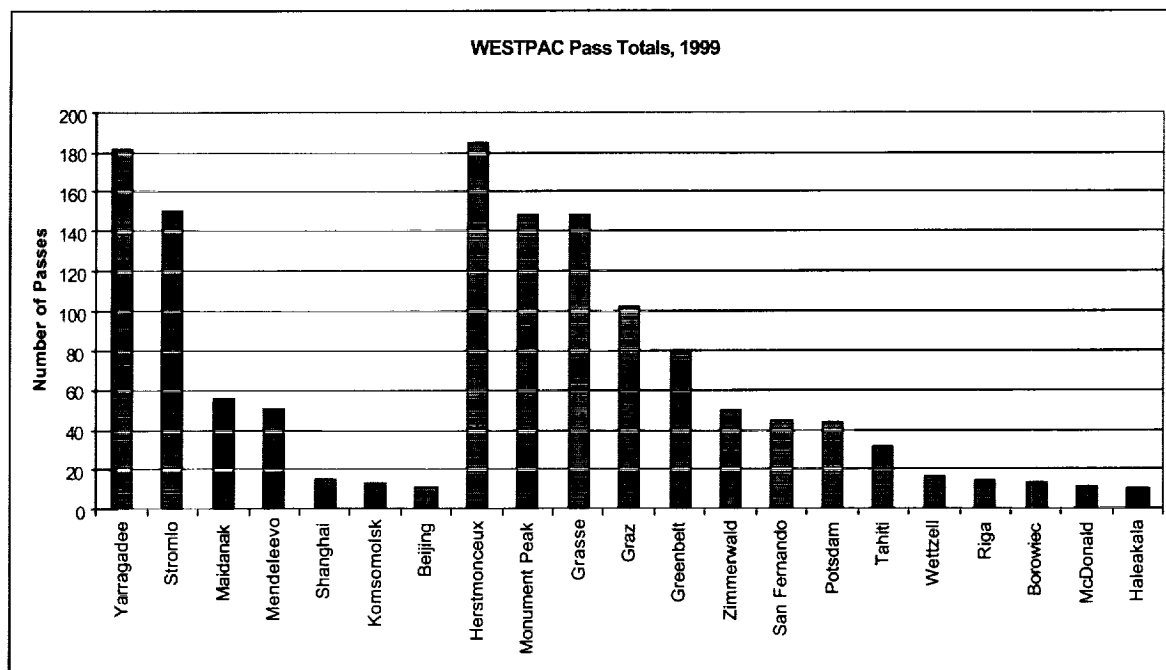

Figure 4.3.1-2 WESTPAC passes acquired during 1999, excluding week 4. From MCC weekly data summaries. Stations observing less than 10 passes are not shown.

REFERENCES

WPLS (1994): "WPLS'94 Symposium Resolutions," *Proc Ninth International Workshop on Laser Ranging Instrumentation, Vol.3*, pp.887-8

Luton, G., Dawson, J., Govind, R. (1999): "ARPGP98 Observation Campaign Overview", *Proc. Second Workshop on Regional Geodetic Network, Ho Chi Minh City, Vietnam, July 12th-13th 1999*, pp.35-37

4.3.2 RUSSIAN NETWORK

Natalia Parkhomenko, *SRI for Precision Engineering Institute*

The Russian SLR network consists of the Komsomolsk SLR station, Mendeleevo SLR station, Maidanak SLR station, the new SLR station near Moscow, and the MCC Operational Analytic Center (MCC OAC).

KOMSOMOLSK STATION

The Komsomolsk SLR station (1868) site (see Figure 4.3.2-1) is near the Solnechny settlement, on the forest-covered plain northwest of Komsomolsk-on-Amur. The RMS number of cloudless days per year is 56 and the number of totally cloudy days per year is 113. The climate here is of a

pronounced continental type. The period of most frequently cloudless weather is winter, when the air temperature is often below -40°C .

The Komsomolsk SLR station (1868) basic parameters:

- Laser pulsewidth 0.3 ns
- Detector PMT, type ФЭУ-169 (jitter 0.25 ns)
- Counter type ЧЗ-65 (accuracy 30 ps)
- Timing equipment A724M-01 (accuracy 200 ns)
- Reference signal source Rubidium standard frequency oscillator, type Ч1-78
- Barometer type Aneroid barometer (accuracy 0.5 mm Hg)
- Mount type equatorial
- Telescope Two apertures 0.5 m diameter each

The 1868 SLR station is capable to track satellites of any type from the ILRS list, but operates only during nighttime.

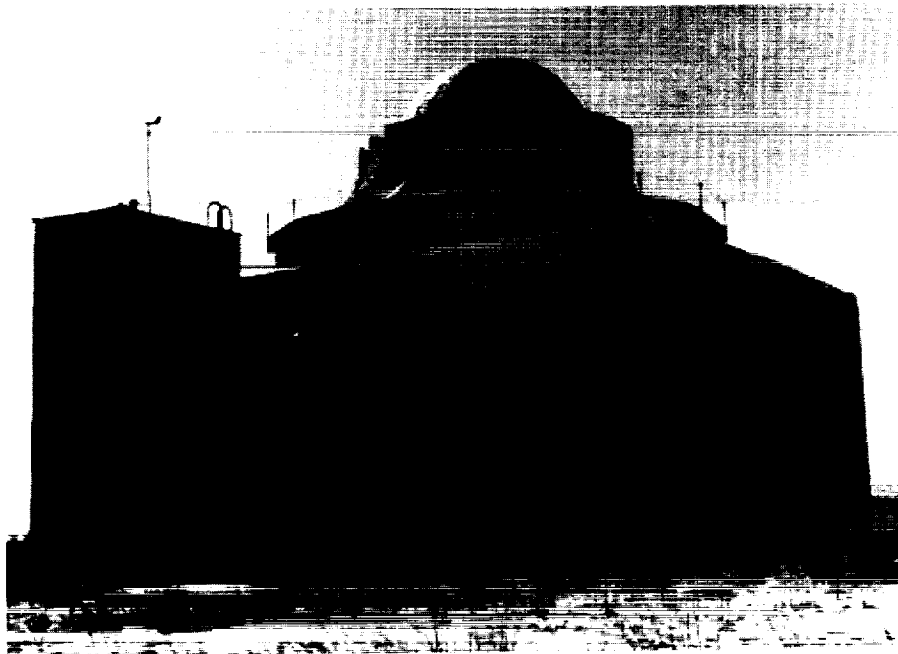

Figure 4.3.2-1. Komsomolsk SLR Station

MENDELEEVO STATION

The Mendeleevo SLR station (1870) site (see Figure 4.3.2-2) is located near Moscow, within the Institute for Time and Space Metrology (ITSM) of the Russian Agency for Standardization (GOSSTANDART of Russia). The RMS number of cloudless and totally cloudy days per year is here 47 and 156 (respectively). In 1999 our primary task was establishing the operation of a third-generation SLR system (GRAN) located not far from the Mendeleevo SLR station.

The Mendeleevo SLR station (1870) basic parameters:

- Laser pulsewidth 6 ns
- Detector PMT, type ФЭУ-165
- Counter RMS error 0.7 ns
- Timing equipment ITSM frequency standard
- Reference signal source ITSM frequency standard
- Barometer type Aneroid barometer (accuracy 0.5 mm Hg)
- Mount type Azimuth/Elevation
- Four mirrors 0.3 m diameter each



Figure 4.3.2-2 Mendeleevo SLR station

MAIDANAK STATION

The Maidanak SLR station (1864) site (see Figure 4.3.2-3) is in Uzbekistan, but is included in the Russian network under an agreement between the Russian Government and the Government of the Uzbek Republic on mutual activities in space research at the Maidanak site, dated December 22, 1997. The RMS number of cloudless and totally cloudy days is here 145 and 79, respectively. The period of mostly cloudless weather is in summer and autumn.

The Maidanak SLR station (1864) basic parameters:

- Laser pulsewidth 0.3 ns
- Detector PMT (Hamamatsu H5023)
- Counter SR620
- Timing equipment GLONASS receiver

- Reference signal source Rubidium standard frequency oscillator, type Ч1-78
- Barometer RTB 220B Vaisala
- Mount type equatorial
- Telescope primary mirror diameter 1.1 m

The 1864 SLR station is capable to track satellites of any type from the ILRS list; operates mostly during nighttime.



Figure 4.3.2-3. Maidanak SLR Station

SHELKOVO STATION

The newest Russian SLR station at Shelkovo, near Moscow (Figure 4.3.2-4), became operational in 1999. Now we are trying to obtain permission from the Government of Russia for its integration into the ILRS. Another new SLR station is under construction in the Altay region.

Basic parameters of the Shelkovo station:

- Laser pulsewidth 0.15 ns
- Detector PMT (Hamamatsu 5023)
- Counter RMS error 25 ps
- Timing equipment GLONASS receiver
- Reference signal source Rubidium standard frequency oscillator, type Ч1-78
- Barometer type Aneroid barometer (accuracy 0.5 mm Hg)
- Mount type Azimuth/Elevation
- Transmit telescope diameter 0.2 m
- Receive telescope diameter 0.6 m

The station is capable of tracking satellites of any type from the ILRS list (low-orbit satellites and LAGEOS during daytime and nighttime).



Figure 4.3.2-4. Shelkovo (near Moscow) SLR Station

MISSION OPERATIONS AND ANALYTIC CENTER

The MCC OAC is providing ephemeris information (IRVs) for the Russian SLR network stations. The station's operation control is made through cooperation between the MCC OAC and the Institute for Precision Instrumental Engineering (IPIE); for the Mendeleev SLR station – the ITSM. The IPIE is also providing technical support for the operation of all stations (for the Mendeleev SLR station – in collaboration with the ITSM). The full rate data from all of the above SLR stations, after pre-processing, are sent via e-mail to the MCC OAC where an analysis is made of the data and normal points are obtained. The normal point data are then sent via e-mail to the EDC.

This procedure causes some additional delay (in comparison with other ILRS stations) in the Russian network data transfer, partly because of the five-day operation week of the MCC OAC (while the stations operate every day). Now the IPIE and MCC OAC are discussing the implementation of normal point computation at the SLR stations, and a direct transmission of normal point data from the stations to the data centers in parallel to the data transfer to MCC OAC.

The Russian SLR station equipment has been developed and implemented by the Laser Division of the Russian Institute for Space Device Engineering. On the basis of this Division, an independent enterprise has been created – the R&D Institute for Precision Instrument Engineering (IPIE), within the Russian Aerospace Agency (ROSAVIAKOSMOS). The IPIE is the leading Russian enterprise in the development and manufacturing of cube corner retroreflectors and retroreflector systems for satellite laser ranging, as well as of special laser technology satellites.

ROSAVIAKOSMOS has authorized IPIE to coordinate the operation of all Russian SLR stations, including the Russian/Uzbek 1864 station (Maidanak).

KEY POINTS OF CONTACT

Chief Coordinator of the Russian SLR network:

- Prof. Victor Shargorodsky, Chief Designer of IPIE.

Chief scientific consultant of the Russian SLR network:

- Prof. Vladimir Vasiliev (IPIE).

Executive coordinator:

- Dr. Natalia Parkhomenko (IPIE).

Representative of the Mendeleevo SLR station:

- Dr. Mark Kaufman (ITSM, GOSSTANDART of Russia).

MCC OAC Contacts:

- Dr. Vladimir Glotov
- Mr. Mikhail Zinkovsky.

See the ILRS web-site for contact information

4.3.3 CHINESE NETWORK

Yang Fumin, *Shanghai Observatory*

INTRODUCTION

The Chinese SLR network (see Figure 4.3.3-1), which consists of Shanghai, Wuhan and Changchun stations, was set up in 1989. The operation and data centers are located in the Shanghai Observatory. The Beijing station started tracking in 1992 (Wang, 1994). The Kunming station first got the returns from LAGEOS in the winter of 1998 (Zhang, 1998). The first Chinese mobile system (CTLRS-1) started ranging in 1996 (Xia, 1996). The second (CTLRS-2) will be completed in 2000 (Guo, 1998). Therefore, the Chinese SLR network will have 5 fixed stations and 2 mobile system in 2000. The performance of the stations has been greatly improved since 1997.

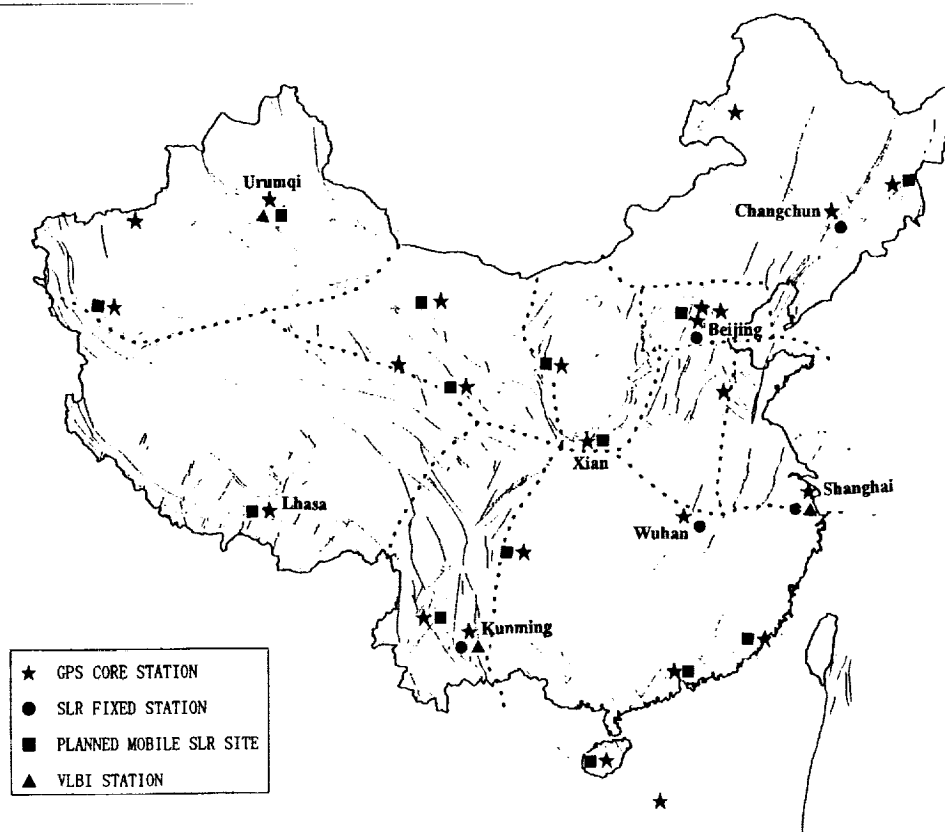

Figure 4.3.3-1 Distribution of the fixed SLR stations and the planned mobile sites

There is a cooperation agreement, supported by the Ministry of Science and Technology in China, between the National Astronomical Observatories, the Chinese Academy of Sciences and the San Juan Observatory in Argentina to host a new fixed Chinese SLR station at the San Juan Observatory by the end of 2001. The characteristics of this SLR system will be the same as the Beijing station.

PERFORMANCE OF THE CHINESE SLR STATIONS

The characteristics of the Chinese stations are listed in Table 4.3.3-1. Active-passive mode-locked Nd:YAG lasers (100mj, 200ps) are used in Changchun, Beijing and Kunming, and SFUR mode-locked Nd:YAG lasers (30-50mj, 50-100ps) are used in Shanghai, Wuhan and CTLRS-1, -2. Most of the stations are equipped the C-SPAD receivers. All stations have the HP58503A GPS time and frequency receivers. Most of the above-mentioned instruments, which were supported by the "Crustal Movement Observation Network of China (CMONOC)," have been installed since 1998.

CITY	SHANGHAI	CHANGCHUN	BELJING	WUHAN	KUNMING	CTLRS-1	CTLRS-2
Station ID	7837	7237	7249	7236/7231	7820		
Aperture of Receiving Telescope	60 cm	60 cm	60 cm	60 cm	120 cm	35 cm	35 cm
Aperture of Transmitter	15 cm	15 cm	16 cm	10 cm	120 cm	10 cm	10 cm
Mount and Pointing Accuracy	Alt-AZ 5arcsec	Alt-AZ 5arcsec	Alt-AZ 5arcsec	Alt-AZ 10arcsec	Alt-AZ 1arcsec	Alt-AZ 10arcsec	Alt-AZ 10arcsec
Pulse Energy (532 nm)	30-50mj	50-100mj	50-100mj	30-50mj	100-150mj	30mj	30-50mj
Pulse Width	50-100ps	200ps	200ps	50-100ps	200ps	50-100ps	50-100ps
Repetition Rate	4-8 Hz	4-5 Hz	4-10 Hz	4-5 Hz	4-5 Hz	4-5 Hz	4-5 Hz
Type of Receiver	C-SPAD	C-SPAD	C-SPAD	C-SPAD MCP-PMT	MCP-PMT C-SPAD	MCP-PMT	C-SPAD
Time Interval Unit	HP5370B	HP5370B	HP5370B	HP5370B	SR620	SR620	SR620
Frequency Standard	HP58503A	HP58503A	HP58503A	HP58503A	HP58503A	AOA/ TTR6A	HP58503A
Ranging Precision	1-2 cm	1-2 cm	1-2 cm	2-3 cm	2-3 cm	2-3 cm	2-3 cm
Operation	Since 1983	Since 1992	Since 1994	Since 1988	Since 1998	Since 2000	Since 2000

Note: 7837 Shanghai Observatory, Chinese Academy of Sciences
7237 Changchun Satellite Observatory, Chinese Academy of Sciences
7249 Chinese Academy of Surveying and Mapping (Beijing)
7236/7231 Institute of Seismology, the State Bureau of Seismology and Institute of Geodesy and Geophysics, Chinese Academy of Sciences. 7236 is the site in the down town, 7231 is the new site in the suburbs (Wuhan)
7820 Yunnan Observatory, Chinese Academy of Sciences (Kunming)
CTLRS-1 Xian Institute of Surveying and Mapping
CTLRS-2 Institute of Seismology (Wuhan)

Table 4.3.3-1 Characteristics of the Chinese SLR Stations (April 2000)

The single-shot ranging precision on LAGEOS for Shanghai, Changchun and Beijing is about 12-20 mm; for Wuhan, Kunming and the mobile systems it is 20-30 mm. Upgrades of ranging precision and system stability for all stations are under way.

The Shanghai station (see Figure 4.3.3-2) has developed a multi-satellite alternate tracking and control system and can easily change tracking objects within 20 seconds. Shanghai station also has daylight tracking capability (Yang, 1999).



Figure 4.3.3-2 Shanghai Station

The Changchun station (see Figure 4.3.3-3) has good weather and had achieved the requirements of the ILRS standards both in data quality and quantity (Zhao, 1998). The Changchun station interrupted tracking during the summer of 1999 for the installation of new encoders for both axes.

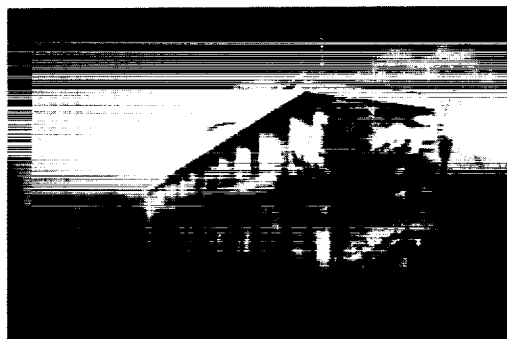

Figure 4.3.3-3 Changchun Station

Data stability and availability have improved at the Beijing station (see Figure 4.3.3-4) in 1999. The new Kunming station (see Figure 4.3.3-5) obtained about 200 passes on LAGEOS in 1999.



Figure 4.3.3-4 Beijing Station

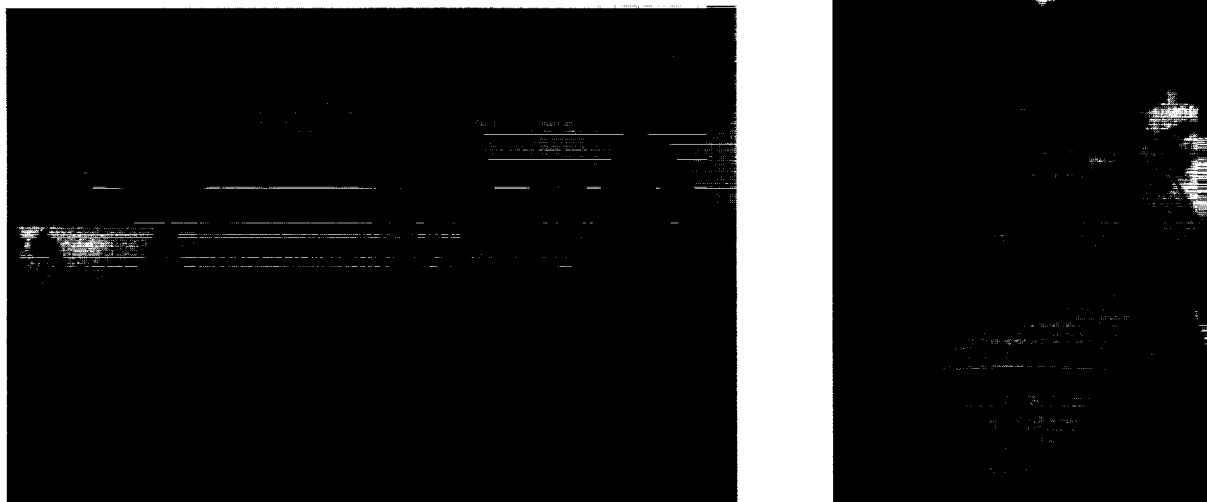

Figure 4.3.3-5 Kunming Station

The Wuhan SLR system (see Figure 4.3.3-6) was moved to a new observation site in the southeast suburbs of Wuhan, 15 km from downtown in December of 1999. Tracking began at the new site in April 2000 and some data has been sent to CDDIS.

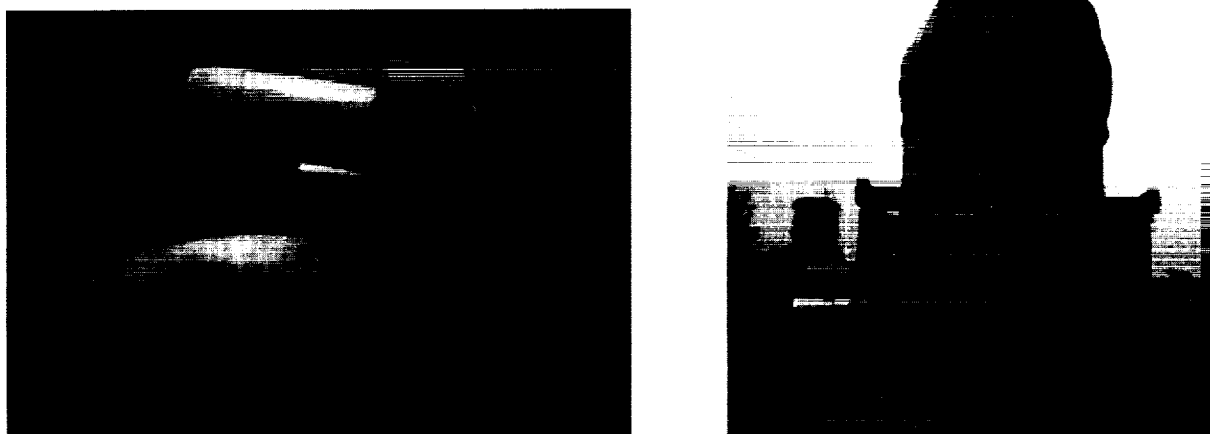

Figure 4.3.3-6 Wuhan Station

The system biases for most of the stations are carefully reviewed. Calibration techniques and local surveys are investigated thoroughly. The short distance targets were set up and tested in Shanghai, Changchun and Wuhan. Table 4.3.3-2 tabulates some short distance calibrations at the Shanghai Observatory. The target is in the dome in front of the telescope. The distance between the target and the reference point of the system is about 2 meters. The target setup is similar to the design of Graz station (Kirchner, 1996). Figure 4.3.3-7 lists the summary of the observations of Chinese SLR network during the period 1994-1999.

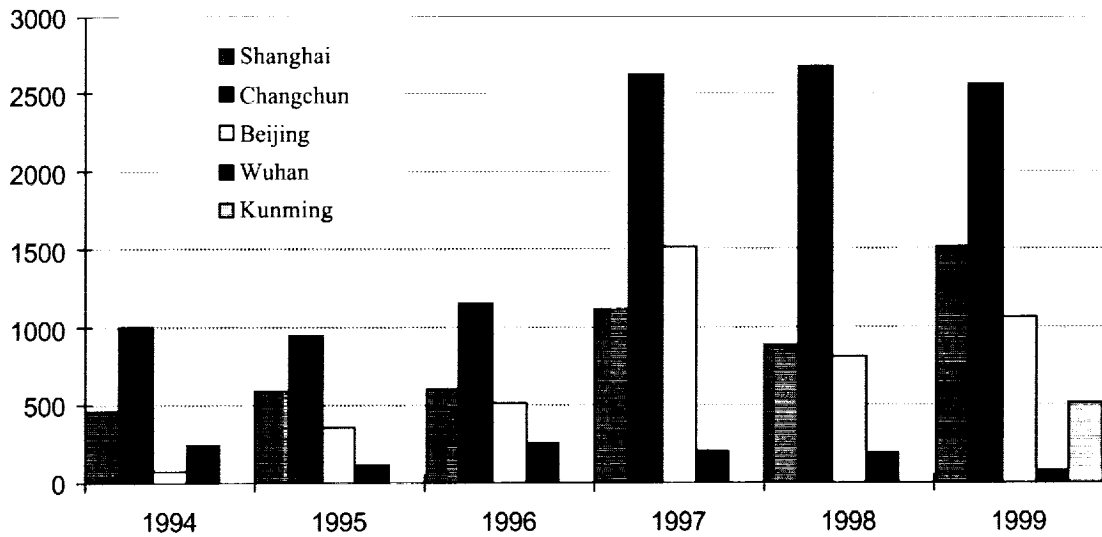

Figure 4.3.3-7 Summary of the Observations of Chinese SLR Network

Calibration (ps)	rms (mm)
80021	5.3
80026	4.7
80021	4.2
80026	5.2
80024	4.7

Table 4.3.3-2 The short distance calibration at Shanghai (April 7, 2000)

Pictures of CTRLS-1 and CTRLS-2 are shown in Figures 4.3.3-8 and -9. The SLR system under development for the San Juan Observatory is shown in Figure 4.3.3-10



Figure 4.3.3-8 CTRLS-1

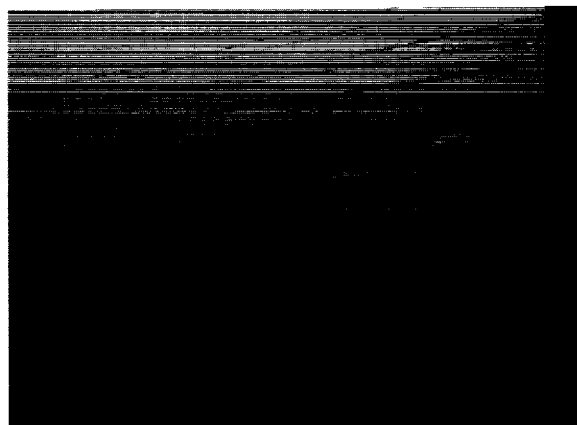
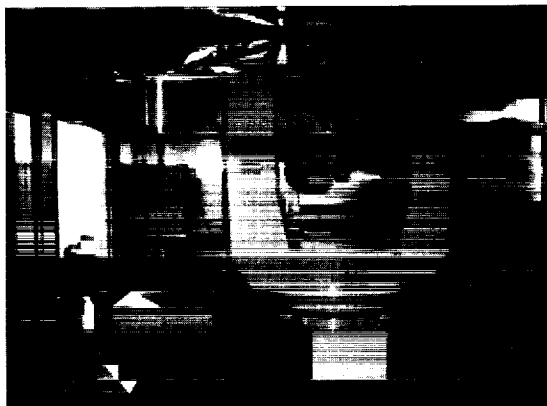

Figure 4.3.3-9 CTRLS-2

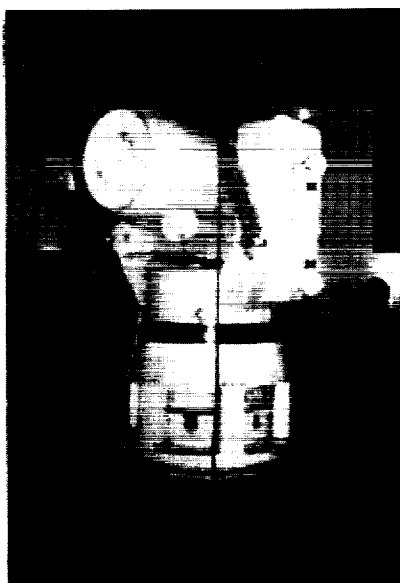

Figure 4.3.3-10 SLR Telescope for San Juan Observatory, Argentina in assembly room

THE OPERATION OF THE CHINESE SLR NETWORK

Figure 4.3.3-1 shows the location of the 5 fixed stations and the planned sites of the CMONOC project to be visited by the 2 mobile stations during the next three years.

The Operation Center, the Data Center and the Analysis Center for the Chinese SLR network have been set up at Shanghai Observatory. The Information on the Shanghai Regional Date Center and the Shanghai Associate Analysis Center can be found in Sections 6 and 7 of this Report.

ACKNOWLEDGEMENTS

We are grateful to NASA for providing support to much of the equipment for the Chinese SLR stations and to CRL Japan for providing support to a calibration package for Changchun station.

REFERENCES

- Guo, T.Y., Xia, Z.Z., et al.: 1998, CMONOC Transportable SLR System, *Proceedings of 11th International Workshop on Laser Ranging*, Deggendorf, Germany, pp.121-125.
- Kirchner, G., Koidl, F.: 1996, Short Distance Calibration, *Proceedings of 10th International Workshop on Laser Ranging Instrumentation*, Shanghai, China, pp.145-148.
- Wang, T. Q.: 1994, Current Status of Beijing SLR Station, *Proceedings of 9th International Workshop on Laser Ranging Instrumentation*, Canberra, Australia, pp.248-257.
- Xia, Z.Z., et al.: 1996, A Transportable Laser Ranging System in China (CTLRS), *Proceedings of 10th International Workshop on Laser Ranging Instrumentation*, Shanghai, China, pp.160-166.
- Yang, F.M., Xiao, C.K., et al: 1999, Design and Observations of the Satellite Laser Ranging System for Daylight Tracking at Shanghai Observatory, *Science in China, Series A*, Vol.42, No.2, pp.198-206.
- Zhang, S.X., Jiang, C.G., et al.: 1998, Status report on Developing of Kunming Laser Ranging System (KLRS), *Proceedings of 11th International Workshop on Laser Ranging*, Deggendorf, Germany, pp.145-148.
- Zhao, Y.: 1998, Upgrade of Changchun SLR System, *Proceedings of 11th International Workshop on Laser Ranging*, Deggendorf, Germany, pp.188-196.

4.3.4 AUSTRALIAN NETWORK

John Luck, *Australian Surveying and Land Information Group*

INTRODUCTION

A contract between AUSLIG and EOS to build a new SLR station based on the Keystone design, at Mount Stromlo Observatory near Canberra (Figure 4.3.4-1), was signed on 3 November 1997. The Stromlo station was commissioned on 28 October 1998. Accordingly, the Orroral Geodetic Observatory ceased SLR activity on 1 November 1998. The Orroral equipment belonging to NASA, principally the telescope, ranging computer and much of the laser, was returned in July 1999 to NASA Marshall Space Flight Center for use in its Laser Lightcraft project. The Observatory site has been restored to nature, with all buildings and facilities being demolished with the exception of the circular main building and dome which has been secured, and the survey monuments. Even the access track has been dug up. The site passed a stringent environmental assessment and was handed back to the A.C.T. Government on 13 March 2000.



Figure 4.3.4-1a Mount Stromlo SLR Station (7849): Canberra in the background, Mt. Stromlo Observatory to the right. Note two calibration piers in lower left part of the picture.



Figure 4.3.4-1b Mount Stromlo SLR Station (7849): The SLR building, highlighting the sealed dome and its window.

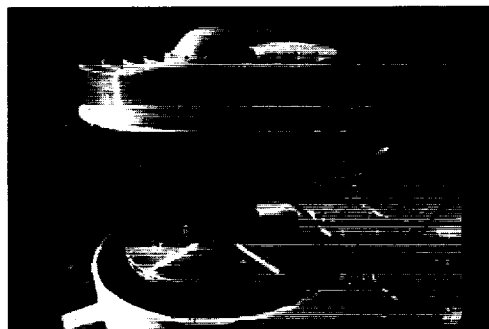

Figure 4.3.4-1c Mount Stromlo SLR Station (7849): Top of the main calibration pier, showing GPS antenna, target retroreflector, survey pillar plate, and protective outer tube of the support pillar.

Under a revision to the Agreement between AUSLIG and NASA for Cooperation in Space Geodesy, AUSLIG took over the operational funding for MOBLAS 5 at Yarragadee (Figure 4.3.4-2) from 1 April 1999 until 30 June 2002 through a contract with British Aerospace Australia (now BAE Systems). NASA continues to provide logistical and maintenance support. Several options are being considered for the continuance of SLR from Western Australia upon the expiry of that contract. The land adjacent to the Yarragadee station is being developed for a

private space communications facility by BAE Systems for Universal Space Network, with the potential for shared power, water, optical fibre communications and transport facilities.

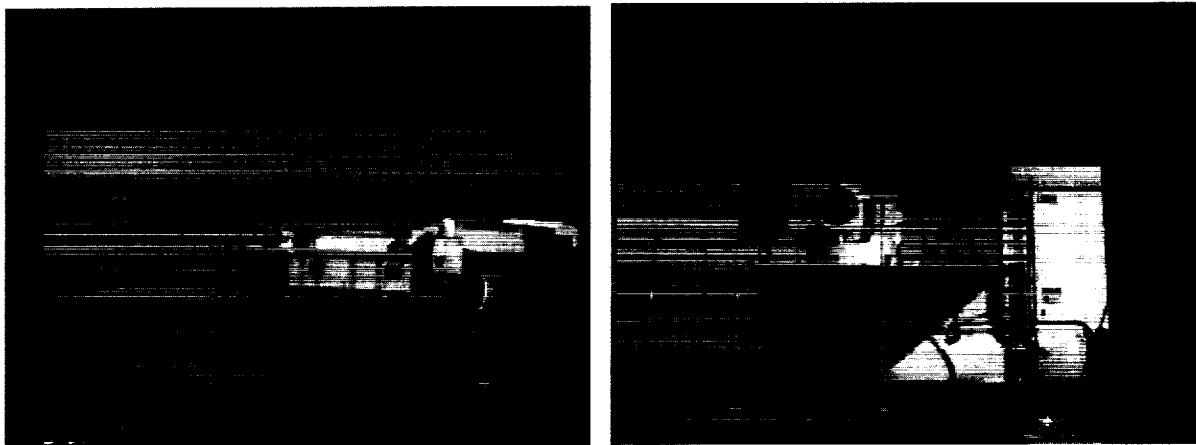

Figure 4.3.4-2: Moblas 5 (7090), Yarragadee, Western Australia

TECHNOLOGY DEVELOPMENT

This section summarizes only those developments occurring at the Mount Stromlo station (Luck, 2000). They include:

- Autonomous ranging. During parts of evenings and weekends, ranging is routinely performed automatically and unattended. It can also be controlled remotely by the Station Manager in the comfort of his own home. Productivity during autonomous sessions is still noticeably lower than when attended, but improvements to the prediction procedure and the acquisition & tracking algorithm are expected to rectify this.
- Aircraft detection by using a 1540nm laser through the ranging telescope appears to be satisfactory; no incidents have yet been recorded.
- A cloud monitor is nearing completion. It will have a 7° field of view and be mounted adjacent to the window in the dome, so it tracks with the telescope. This is an important adjunct to autonomous ranging.
- A high-energy laser is in use by EOS for tracking uncooperative targets. It currently delivers 1.2J at 532nm in 12ns at 20 Hz, through the normal ranging telescope. It is planned to increase the power considerably and convert to the eyesafe wavelength of 1570nm in due course. It should be useful as a “finder” laser for lunar ranging, and as a link budget probe using the OPTUS B geostationary satellites.
- A project to convert normal ranging from 532nm to 1570nm is under consideration.

LOCAL TIE SURVEYS

A cycling program of local tie surveys has been instituted by AUSLIG to support its whole range of activities in space geodesy. New software for determination of instrumental reference points has been written. Computations have been completed for the following fundamental sites and their SINEX files submitted to IGN/IERS for ITRF2000:

- Hobart VLBI and IGS GPS, observed 1995;
- Tidbinbilla VLBI and IGS GPS, observed 1995;
- Yarragadee SLR, IGS GPS, IGEX GLONASS, DORIS and SLR calibration targets, observed mainly August 1998;
- Orroral SLR, GPS and DORIS, observed November 1998 – closeout;
- Stromlo SLR, IGS GPS, IGEX GLONASS, DORIS and SLR calibration targets, observed June and December 1999.

They all include ties to the fiducial monuments at each site and local reference marks. A comprehensive report is in preparation.

The Stromlo survey of the telescope intersection of axes is complemented by the availability of four ground targets used for laser ranging. The solutions by the two independent methods agree to 1 mm.

ANALYSIS

AUSLIG's Space Geodesy Analysis Centre is an ILRS Associate Analysis Center, contributing regular solutions to IERS and to the deliberations of the Pilot Project of the Analysis WG. See section 7.1.3.6.

COLLABORATIONS

Substantial amounts of the demolished Orroral station were donated to KACST for the refurbishment of SALRO by EOS. Some returns were received from AJISAI in December 1999, giving hope that SALRO might one day be productive again.

The ex-Orroral 1-Angstrom Fabry-Perot filter was donated to Kunming, to aid their efforts to achieve daylight ranging.

REFERENCE

Luck, J.McK. *'SLR Activities in Australia and WPLTN'*, presented at EGS XXV General Assembly, 25 April 2000.

4.4 LUNAR NETWORK

Peter Shelus, *University of Texas*

The present LLR network consists of the OCA station in France and the MLRS station in the USA. Both stations operate in a multiple target mode, observing many targets other than the lunar surface retroreflectors. The MLRO is a joint SLR/LLR station, presently under construction, to be installed in Matera, Italy. Operations of the MLRO should commence early in 2000. Finally, although LLR data has been gathered during previous years, by the Wettzell SLR station in Germany, station upgrades and other operational matters prevented LLR data from being obtained in 1999. It is expected that LLR data will be forthcoming from Wettzell during 2000.

OBSERVATOIRE DE LA COTE D'AZUR (OCA)

The OCA station, located in southern France on the Calern Plateau near Grasse, performed well during 1999 with no major incidents. The weather conditions were good during the spring and exceptionally good during November. This year, the OCA observing program has changed dramatically from previous years in that it is no longer a lunar only program. It is now divided among the four retroreflectors on the Moon, the two LAGEOS targets, and the several high altitude artificial satellites (GLONASS, Etalon, and GPS). Despite this large increase in the number of targets under observation, the 1999 data yield for the Moon remains excellent. In fact, both the number of returns and the number of normal points are at an all time high. The OCA station netted 653 normal points in 1999, twice that of the previous year (which had been particularly difficult). Of even more importance, the average number of returns per normal point is now 93, up from 67 last year.

Validated OCA LLR data are made available through the data centers of the ILRS and can also be retrieved from our local web-site, with a monthly update, in two formats.

The funding of the OCA station has been questioned by national authorities and investigated by a dedicated committee in June 1999. Eventually, based upon the quality of the work carried out, the scientific value of the output and the moderate annual cost (not counting salaries) the committee recommended that the operation should continue for the next four years.

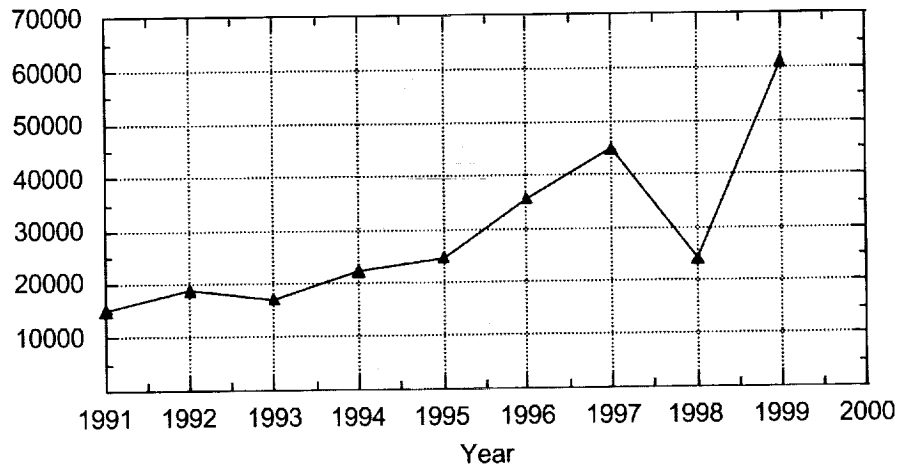

Figure 4.4-1 OCA Annual number of Returned Photons

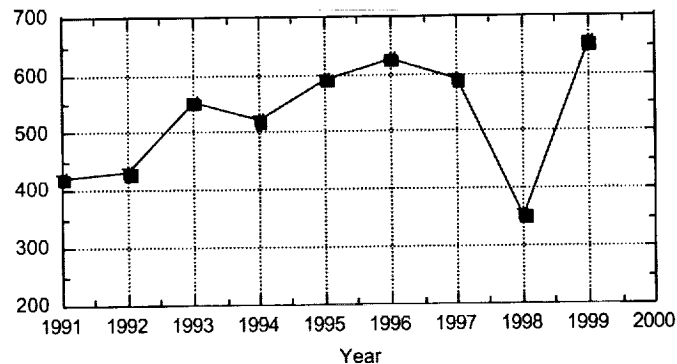

Figure 4.4-2 OCA Annual Number of Return Normal Points

The two figures illustrate the evolution of the OCA LLR data yield over the last several years. Figure 4.4-1 illustrates the number of returned photons. Figure 4.4-2 illustrates the number of normal points.

MCDONALD LASER RANGING STATION (MLRS)

The McDonald Observatory station, MLRS, located in the mountains of west Texas, had an especially difficult year in 1999. Although LLR results had been quite good at the beginning of the year, inclement weather conditions and an unfortunate series of problems with prediction software, conspired to make the 1999 MLRS LLR data throughput, the worst since 1993 (see Figure 4.4-3).

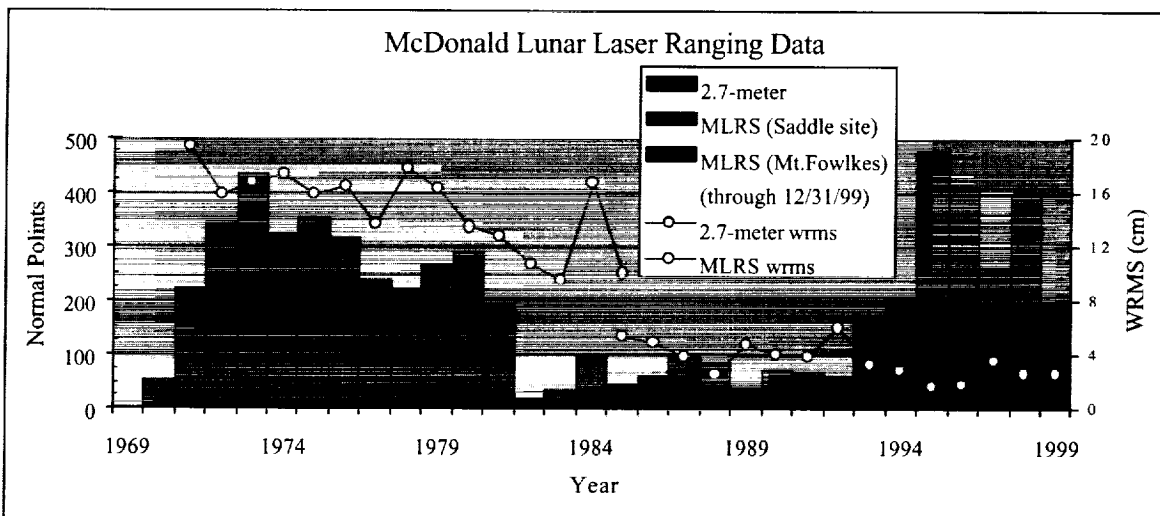

Figure 4.4-3 McDonald Observatory data quality and quantity over the life of the project.

MLRS LLR data are made available through the data centers of the ILRS. All data is transmitted to the data centers in near-real-time, using standard SLR formats.

MATERA LASER RANGING OBSERVATORY (MLRO)

The Italian laser ranging station MLRO is under construction and has not ranged to the moon during 1999. However, lunar observations had been performed successfully during test firings in 1998 when the station was at the Goddard Space Flight Center's GGAO site in Greenbelt, MD. Those data files are presently under investigation. The installation of the station at the site in Matera was begun at the end of 1999 and is progressing nicely. The telescope is in the dome, the optical tables are in the clean rooms, and the remainder of the system is being assembled. It is expected that the system will be operational by end of February and be ready for routine operations, including LLR sessions, by the summer.

KEY POINTS OF CONTACT

OCA:

Francois Mignard
OCA/CERGA
Av N. Copernic
06130 Grasse, FRANCE
francois.mignard@obs-azur.fr

MLRS:

Peter J. Shelus
McDonald Observatory
University of Texas at Austin
Austin, TX 78712-1083, USA
pjs@astro.as.utexas.edu

MLRO:

Dr. Giuseppe Bianco
Agenzia Spaziale Italiana (ASI)
Centro Geodesia Spaziale
P.O. Box 11
75100 Matera (MT), ITALY
bianco@asi.it

SECTION 5

OPERATIONS CENTER REPORTS

SECTION 5 - OPERATIONS CENTER REPORTS

The Operational Centers are in direct contact with tracking sites organized in a subnetwork. Their tasks include the collection and merging of data from the subnetwork, initial quality checks, data reformatting into a uniform format, compression of data files, if requested, maintenance of a local archive of the tracking data and the electronic transmission of data to a designated ILRS Data Center. Operational Centers can perform limited services for the entire network. Individual tracking stations can also perform part or all of the tasks of an Operational Center themselves.

The ILRS has two SLR Operations Centers, the Mission Control Center in Moscow, Russia and the NASA Goddard Space Flight Center in Greenbelt, MD USA. The University of Texas also operates the LLR Operations Center in Austin, Texas USA.

5.1 MISSION CONTROL CENTER

Vladimir Glotov, *Russian Mission Control Center*

INTRODUCTION/FUNCTIONS PROVIDED; PREDICTIONS

The MCC's activity, as the Operation Center of Russian SLR network, began in 1990. Before that time most of the people involved had an active role in the MCC ballistic service for space missions supported by the MCC. Built in 1973, the Mission Control Center controls the Mir (early Salyut) orbital manned stations, the Soyuz space shuttles, the Progress space trucks, space science kits for orbital complexes, the reusable Buran space shuttle and the un-crewed space probes to Venus, Mars, Zond, Vega and Phobos. As a scientific body the Center also does its own research, solving specific spaceflight control.

Many experts in control systems, space technology, ballistics, telemetry, communications and tracking systems manage spaceflights, and officers from scientific institutions share the experiments and research. The mission program and the crew's safety depends on this group of people. Therefore the Mission Control Center is backed up with state-of-the-art technology. In particular, it has powerful message-transmitting equipment, facilities to gather information, etc. Tracking-telemetry/control (TTandC) stations implement all of the decisions in flight control operations. The TTandC stations communicate with the MCC by telegraph, telephone and television.

By the beginning of the 1990's the MCC ballistic service had accumulated more than 20 years of experience in the data gathering, storing and processing. The Russian SLR stations are part of different Russian networks, and therefore the MCC is responsible for coordinating the SLR activity. Stations transfer their data directly to the MCC.

In parallel with precise SLR data analysis (see Section 7.1.2.3.), MCC supports the collection of raw data from the Russian stations and provides the SLR community with corresponding normal points. In order to improve the quality of the data, limited mostly by equipment, the MCC has carried out upgrade work with the designers and operators of the equipment. As a result, the performance of Maidanak (1864) in 1995 and Komsomolsk (1868) in 1997 has been markedly improved.

Thus the Mission Control Center's next main tasks, as Operation Center of Russian SLR network, are:

- Permanent monitoring of SLR-stations data quality, cooperation with the station developers and staff in the analyses of station failures and developing approaches of station SLR-data improvement;
- Delivery of satellite predictions, tracking schedules and technical information to SLR-stations;
- Collection, quality check, failure detection of raw SLR data from tracking stations; NP generation for all stations and satellites;
- Transforming tracking data into international data formats (FR, QL, QL-NP), transferring SLR-data to International Global Data Centers (EDC, CDDIS)
- Cooperation with international services and Data Storage Centers in satellite tracking files and checking the quality of transfers of SLR-data;

- Cooperation with Russian SLR stations in the solving of technical problems during the station operation (in cooperation with RISDE - Head Russian SLR stations development and operation institution)

Starting in 1998 the MCC became the official processing center for the WPLTN. Currently the MCC supports Westpac satellite missions with IRVS predictions. Normally they are determined on a 1-2 week's basis with a slight tendency to reduce the time intervals in 1999 due to the increase in Solar activity. In 1999 Dr. Zhao You of the Chinese Academy of Science invited two MCC SLR Center experts (Dr. V. Glotov and Dr. V. Mitrikas) in the area of WPLTN station maintenance and development to visit China. They visited two Chinese SLR stations: Changchun and Beijing. Dr. Glotov and Dr. Mitrikas in the cooperation with Chinese experts from Changchun, Beijing and Shanghai SLR stations made the detailed long-term analyses of Chinese station SLR data quality and error sources leading to data quality degradation. Special recommendations concerning satellite tracking and calibration were developed.

STATIONS SUPPORTED

Since 1991 MCC, as the Operation Center of Russian SLR network, controlled the following SLR-stations:

- Maidanak-1 (1863) and Maidanak-2 (1864)
- Balkhash (1869)
- Evpatoria (1867)
- Komsomolsk (1868)
- Katzively (1893)
- Mendeleevo (1870 - station with old design)
- Sarapul (1871 - station with old design)

Unfortunately, at this time only the following stations are operational: Maidanak-2, Komsomolsk-na-Amure, Mendeleevo (old station) and Katzively (operational only in summer). The Evpatoria station (1867) belongs to Ukraine, and the Balkhash station to Khazakstan. The MCC was able to make an agreement concerning the operation of the former USSR SLR stations in Uzbekistan (station Maidanak).

Thus, MCC controls 4 operational SLR stations now: Maidanak-2, Komsomolsk, Katzively and Mendeleevo (1870, old design). MCC Operation Center also takes part in testing new SLR stations. The 1999 SLR tracking results for the Russian network for low satellites, high satellites and GLONASS is shown in Table 5.1-1.

RISDE, the developer of SLR stations, plans to create a new SLR station in the Altai region and to resume operation of Maidanak-1 station.

<i>1999</i>											
Site Name	Sta	ER1	ER2	BEC	STR	STL	WES	GFO	TPX	AJI	Total
Komsomolsk	1868	69	62	5	43	46	13	0	113	113	459
Maidanak	1864	27	72	0	0	0	55	0	76	0	230
Mendeleevo	1870	91	85	0	35	44	46	36	55	41	433
Katzively	1893	0	0	1	0	0	0	0	5	0	6

Site Name	Sta	LA1	LA2	ET1	ET2	G35	G36	Total
Komsomolsk	1868	68	57	35	18	0	5	183
Maidanak	1864	129	96	30	30	24	18	327
Katzively	1893	17	15	0	0	0	0	32

Site Name	Sta	G62	G66	G68	G69	G70	G71	G72	G75	G79	G80	Total
Komsomolsk	1868	0	9	0	0	0	14	14	0	4	11	52
Maidanak	1864	1	6	8	14	20	11	33	1	35	6	135
Katzively	1893	0	4	0	0	0	0	3	1	8	1	17

Table 5.1-1 Number of Passes Tracked by the Russian Network in 1999

FACILITY/CURRENT STATUS

There are two branches of the software used for routine service by the laser group of the MCC. The first is STARK, initially prepared as general software for usual missions with high accuracy. The other software, POLAR, is much more complicated and used now at the MCC for determination of highly accurate orbits, earth orientation parameters, sets of station coordinates, biases, station performance, etc. (see Section 7.1.2.3).

The first version of STARK was developed in 1993 to run under the DOS system for PC. It can adjust a maximum of 8 parameters (solar pressure and atmosphere drag in addition to state vector). STARK contains special dedicated database for state vectors, measurements, models, station coordinates, EOP, etc. The STARK software package has been designed to support satellite mission operations, orbit determination, "NP-QL" generation, orbit and complex tracking data analysis.

There are comprehensive graphics with many features in the software to compare orbits, to monitor measurement residuals. It is possible to calculate some general ballistic information such as visibility, shadow, etc. STARK has been tested for many actual missions, from reentering objects to satellites above geostationary. It is used to compute preliminary orbits and to build normal points for almost all missions supported by ILRS. Until 1998 STARK and POLAR were under permanent improvement of models and algorithms.

The STARK and POLAR SW packages run on Standard IBM compatible Pentium computers.

KEY POINTS OF CONTACT

Coordinator of the work	Vladimir Glotov	cnss@mcc.rsa.ru
Person responsible	Michael Zinkovsky	cnss@mcc.rsa.ru
Administration support	Sergey Revnivych	cnss@mcc.rsa.ru

5.2 NASA GODDARD SPACE FLIGHT CENTER

David Carter, *National Aeronautics and Space Administration*

Scott Wetzel, *Honeywell Technology Solutions, Inc.*

INTRODUCTION

The NASA SLR Operational Center is responsible for:

- NASA SLR network control, sustaining engineering, and logistics
- ILRS mission operations
- ILRS and NASA SLR data operations

NASA SLR network control and sustaining engineering tasks include technical support, daily system performance monitoring, system scheduling, operator training, station status reporting, system relocation, logistics and support of the ILRS Networks and Engineering Working Group. These activities ensure the NASA SLR systems are meeting ILRS and NASA mission support requirements.

ILRS mission operations tasks include mission planning, mission analysis, mission coordination, development of mission support plans, and support of the ILRS Missions Working Group. These activities ensure that new mission and campaign requirements are coordinated with the ILRS.

Global Normal Points (NP) data, NASA SLR FullRate (FR) data, and satellite predictions are managed as part of data operations. Part of this operation includes supporting the ILRS Data Formats and Procedures Working Group.

Global NP data operations consist of receipt, format and data integrity verification, archiving and merging. This activity culminates in the daily electronic transmission of NP files to the CDDIS. Currently of all these functions are automated. However, to ensure the timely and accurate flow of data, regular monitoring and maintenance of the operational software systems, computer systems and computer networking are performed. Tracking statistics between the stations and the data centers are compared periodically to eliminate lost data. Future activities in this area include sub-daily (i.e., hourly) NP data management, more stringent data integrity tests, and automatic station notification of format and data integrity issues.

FR is not an ILRS required data product, but FR data from the NASA SLR network is automatically received, processed, and transmitted to the CDDIS in daily files.

Daily satellite predictions are generated and distributed to the stations and the ILRS data centers (i.e., the CDDIS and EDC) for every ILRS and NASA supported satellite. Daily predictions have eliminated the need of time bias functions and are required to support very low earth altitude satellite missions like CHAMP, ICESAT, and VCL.

The NASA SLR Operations Center is located at:

Honeywell Technology Solutions Inc. (HTSI)/NASA SLR and VLBI
Goddard Corporate Park
7515 Mission Drive
Lanham, Md 20706, USA

HTSI (see Figure 5.2-1), formerly AlliedSignal Technical Services Inc. (ATSC), formerly Bendix Field Engineering Corp (BFEC), has been the NASA SLR operation center contractor since November 1983, the start date of the consolidated NASA SLR mission contract. Prior to this consolidation, NASA had three distributed SLR operation centers located at BFEC in Greenbelt, MD; at University of Texas (UT) in Austin, TX; and at Smithsonian Astrophysical Observatory (SAO) in Boston, MA. BFEC was the operations center for the NASA developed SLR systems (i.e., MOBLAS 1-8, STALAS, and TLRs-2). UT was the operations center for the UT developed systems (i.e., TLRs-1 and McDonald Laser Ranging System) and SAO was the operations center for the SAO developed systems (i.e., SAO 1-4).

KEY POINTS OF CONTACT

Name	Email	Phone
Carter, David, NASA	dlcarter@pop900.gsfc.nasa.gov	301-614-5966
Brogdon, Oscar, HTSI	oscar.brogdon@honeywell-tsi.com	301-805-3933
Horvath, Julie, HTSI	julie.horvath@honeywell-tsi.com	301-805-3951
Davissan, George, HTSI	george.davissan@honeywell-tsi.com	301-805-3963
Donovan, Howard, HTSI	howard.donovan@honeywell-tsi.com	301-805-3985
Schupler, Bruce, HTSI	bruce.schupler@honeywell-tsi.com	301-805-3992
Stevens, Paul, HTSI	paul.stevens@honeywell-tsi.com	301-805-3960
Wetzel, Scott, HTSI	scott.wetzel@honeywell-tsi.com	301-805-3987
Wu, Frank, HTSI	frank.wu@honeywell-tsi.com	301-805-3962
Yoest, David, HTSI	david.yoest@honeywell-tsi.com	301-805-3983



Figure 5.2-1 HTSI Group Photo

5.3 UNIVERSITY OF TEXAS LLR CENTER

Peter Shelus, *University of Texas*

The University of Texas McDonald Observatory houses the ILRS LLR Operations Center. The small size of the LLR observing network and the relatively small number of LLR analysis centers dictate the unique nature and operational procedures of this LLR Operations Center. Predictions are performed on-site at each station and data are automatically transferred from all observing sites to the Data Centers. Analysts secure their data directly from the Data Centers as needed. Feedback from the analysts often goes directly back to the observing stations. The responsibility of the LLR Operations Center has evolved to be one that assures the smooth flow of data, in a form and format that is useful for obtaining scientific results. The center also coordinates the observations and their scheduling in a manner to maximize the scientific gains. Consider the following.

During the early years of the LLR experiment, the main emphasis had always been upon securing the maximum amount of data possible. Getting signal photon returns back from the Moon was, and still is, a dauntingly technical challenge. However, in recent years, as the LLR data volume has risen to a reasonable level, the overall experiment has begun an effort to improve the quality of the data, i.e., to improve both the precision and the accuracy of the data products. This entails improving system calibration stability, reducing photon detection jitter, and improving the timing systems. It also entails the investigation into ways of obtaining more and better observations, nearer to the new moon and full moon phases. This is an important effort that should increase the scientific payback of the LLR experiment. In its way, the Operations Center tries to coordinate this activity, serving as the intermediary between the observing stations and the analysis centers.

For instance, the recognized LLR data deficits near the new and full moon phases are well documented. These deficits have the effect of reducing significantly the sensitivity of the Principle of Equivalence violation signal, i.e., $c \times \cos(D)$, where c is a constant and D is the mean elongation of the Moon from the Sun. Roughly speaking, if one visualizes the $0^\circ < D < 180^\circ$ interval of synodic lunar phase between new and full moon, only the interval $40^\circ < D < 160^\circ$ is presently effectively being fitted. In this interval, the function, $\cos(D)$, is virtually linear, with its strongest signal strength being unused. This clearly calls for a concerted attempt to obtain much more data nearer to both the new moon and full moon phases, so long as the accuracy of the data is not affected too much.

Along those same lines, the present LLR data density also lacks symmetry around the first and third quarter lunar phases. More data is present on the full moon side of the monthly lunar cycle. This creates an overlap, or a projection, of the $\cos(D)$ signal onto two other of the partial derivative signals in the basic LLR model, i.e., $-l$ and $\cos(2D)$, l being the mean anomaly of the Moon. If one solves for a hypothesized post-model signal, such as the Principle of Equivalence violation signal, any part of that signal that can be represented by partial derivatives, already in the model, get assimilated by any adjustments of that model. This is presently happening to a significant effect. It results in further reducing the sensitivity of a $\cos(D)$ fit to the data, which is a natural consequence of the asymmetry of data quantity about the quarter moon phases. Thus, LLR stations should attempt to favor observations that are on the new moon side of the lunar quarter phases. This should tend to de-couple the scientifically interesting $\cos(D)$ signal from the l and the $\cos(2D)$ signals.

There are other significantly negative effects of the data gaps at the new moon and the full moon phases, as well as the asymmetry about the quarter moon phases. These attributes couple the $\cos(D)$ signal to the $\cos(3D)$, $\cos(4D)$, etc. signals, and thereby bias the solutions for any $\cos(D)$ amplitude, in propor-

tion to any of these higher Fourier signals from any synodically periodic systematic effect in LLR. Both theoretical and operational features of LLR are dominated by the synodic month cycle. So the present ability to separate an Principle of Equivalence violation signal from other synodic effects is degraded by the properties of the present data distribution.

It should also be noted that there is a deficit of LLR data with sidereal periodicity, i.e., there being fewer observations when the moon is in the southern hemisphere of the celestial sphere. This is because the window for quality observations is smaller, since both LLR-capable stations are located in the Northern Hemisphere. It is especially severe for the OCA station. This can potentially affect analytical fits for a $\cos(D)$ signal, if there are systematic effects in the residuals with annual period, where there presently seem to be. The full ramifications of this sidereal data density modulation are not yet fully understood, but it would suggest that, whenever possible, observations when the moon is in the Southern Hemisphere are favored, as long as observation quality is maintained.

Finally, at a low level, within the UT LLR Operations Center, there has been ongoing a small project to apply Bayesian statistics to better identify LLR data during times of low signal to noise ratio. Several studies have already been performed and a paper was presented at the International Workshop for Laser Ranging, that had been held in Deggendorf, Germany during September, 1998. That paper appears in the formal proceedings of the Workshop.

Progress has been accomplished in the LLR experiment within the UT LLR Operations Center. We are looking forward to another year of successful activity.

KEY POINTS OF CONTACT

Operations Center Manager:
Dr. Peter J. Shelus
McDonald Observatory
University of Texas at Austin
Austin, TX 78712-1083, USA
pjs@astro.as.utexas.edu

LLR Data Formats:
Mr. Randall L. Ricklefs
McDonald Observatory
University of Texas at Austin
Austin, TX 78712-1083, USA
rlr@astro.as.utexas.edu

SECTION 6

DATA CENTER REPORT



SECTION 6 - DATA CENTER REPORTS

In late 1998, the International Laser Ranging Service began operations. Two global data centers and one regional data center currently support the service. Global data centers archive data from the entire ILRS network and provide access to these holdings to the general user community. Furthermore, global data centers archive products derived from the ILRS data as well as any ancillary information, such as site logs, coordinates and eccentricities, relevant electronic communications, and summaries of data holdings. Regional data centers archive data from a subset of the ILRS network; currently, the single ILRS data center at Shanghai is responsible for archiving data for the Asian region. The ILRS data centers and their main contact person are listed in Table 6-1. Operations centers are also listed here for completeness; further discussion on these centers can be found in the operations center section of this annual report.

Data Center	Main Contact
<i>Global Data Centers</i>	
Crustal Dynamics Data Information System (CDDIS), USA	Carey Noll
EUROLAS Data Center (EDC), Germany	Wolfgang Seemueller
<i>Regional Data Centers</i>	
Shanghai Data Center, People's Republic of China	Tan Detong
<i>Operations Centers</i>	
NASA/Honeywell Technical Solutions, Inc. (HTSI), USA	David Carter
Mission Control Center (MCC), Russian Space Agency, Russia	Vladimir Glotov
Center for Space Research (CSR), University of Texas at Austin, USA	Richard Eanes
McDonald Observatory, University of Texas at Austin, USA	Peter Shelus

Table 6-1. Data Centers Supporting the ILRS

The ILRS utilized previously developed data flow paths to provide laser ranging data (both to orbiting satellites and the moon) to the user community. This data flow is shown in Figure 6-1. Table 6-2 lists the laser stations by network and operations/data center; this table illustrates which of the operations or data centers, Honeywell Technical Services, Inc. (HTSI) or the EUROLAS Data Center (EDC), these stations transmit their data to. At a minimum, laser stations forward their data to operations/data centers on a daily basis where they are merged into files by day and satellite for transmission to the global data centers where they are archived. Currently, the two ILRS global data centers make their data holdings available in different directory and file structures as will be discussed in their individual reports. These centers exchange their recently received data at least once per day to ensure that their holdings are equalized and that users can continue to reliably access data should one center be unavailable.

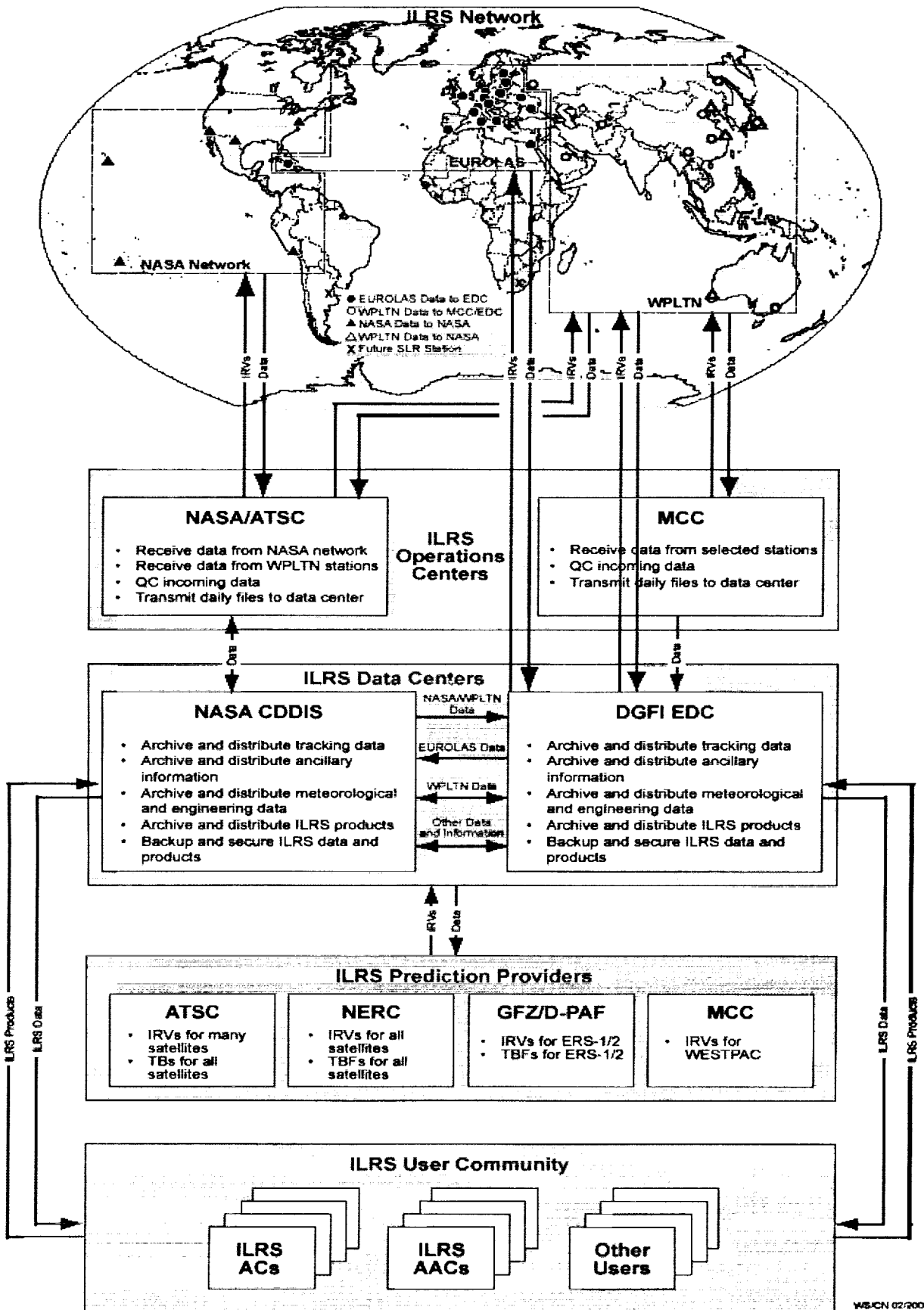

Figure 6-1. ILRS Data Flow

NASA Stations		
<i>Greenbelt, MD, USA</i>	<i>Monument Peak, CA, USA</i>	<i>Arequipa, Peru</i>
<i>Haleakala, HI, USA</i>	<i>McDonald Obs., TX, USA</i>	<i>Tahiti, French Polynesia</i>
WPLTN Stations		
<i>Kashima, Japan</i>	Beijing, China	Komsomolsk, Russia
<i>Koganei, Japan</i>	<i>Changchun, China</i>	Mendeleevo, Russia
<i>Miura, Japan</i>	Kunming, China	Sarapul, Russia
<i>Tateyama, Japan</i>	<i>Shanghai, China</i>	Maidenak, Uzbekistan
<i>Simosato, Japan</i>	Wuhan, China	Mt. Stromlo, Australia
Tokyo, Japan *†	Riyadh, Saudi Arabia †	<i>Yaragadee, Australia</i>
EUROLAS Stations		
Potsdam, Germany	Herstmonceux, UK	Borowiec, Poland
Wetzell, Germany	San Fernando, Spain	Riga, Latvia
Grasse SLR, France	Matera, Italy	Katzively, Ukraine
Grasse LLR, France	Cagliari, Italy	Kiev, Ukraine †
Graz, Austria	Metsahovi, Finland	Simeiz, Ukraine †
Zimmerwald, Switzerland	Helwan, Egypt	Santiago de Cuba *†

Notes: * indicates cooperating SLR station providing data but not part of ILRS

† indicates SLR station not providing data during 1999

SLR stations in *italics* flow data to HTSI; others flow data to EDC

Table 6-2. ILRS Stations by Network and Operations/Data Center

In 1999, over 70,000 passes were recorded by a network of 39 SLR systems. All laser ranging data were made available through the ILRS global data centers, the principle source of data for the user community.

Several current and future SLR missions require data more frequently than once per day in order to update their precise orbit information. Therefore, in 2000, the ILRS will develop data flow, file naming, and other requirements of the infrastructure to permit rapid availability of SLR data and satellite predictions to the user community. Furthermore, operations centers and satellite orbit prediction providers will begin daily generation of satellite prediction files in the tuned IRV format.

6.1 GLOBAL DATA CENTERS

6.1.1 CDDIS REPORT

Carey Noll, *Crustal Dynamics Data Information System*

INTRODUCTION

The Crustal Dynamics Data Information System (CDDIS) has supported the archive and distribution of laser ranging data (both lunar and satellite) since its inception in 1982. This report summarizes the current and future plans of the CDDIS with respect to the International Laser Ranging Service (ILRS). Included here is background information about the CDDIS, its computer architecture, staffing, and archive contents, as well as future plans for the system within the ILRS.

BACKGROUND

The CDDIS has been operational since September 1982, serving the international space geodesy and geodynamics community. This data archive was initially conceived to support NASA's Crustal Dynamics Project. Since the end of this successful program in 1991, the CDDIS has continued to support the science community through NASA's Space Geodesy Program (SGP) and the Solid Earth and Natural Hazards (SENH) activity. The main objectives of the CDDIS are to store all geodetic data products acquired by NASA programs in a central data bank, to maintain information about the archival of these data, and to disseminate these data and information in a timely manner to authorized investigators and cooperating institutions. Furthermore, science support groups analyzing these data submit their resulting data sets to the CDDIS on a regular basis. Thus, the CDDIS is a central facility providing users access to raw and analyzed data to facilitate scientific investigation. A large portion of the CDDIS holdings of GPS, GLONASS, laser ranging, VLBI, and DORIS data are stored on-line for remote access. Information about the system is available via the WWW at the URL:

http://cddisa.gsfc.nasa.gov/cddis_welcome.html

The CDDIS successfully responded to the 1998 Call for Participation in the International Laser Ranging Service (ILRS). This response stated that the CDDIS would support data center activities by providing access to an archive of laser ranging data, both to orbiting satellites (SLR) and to the moon (LLR). This archive consists of data (SLR on-site normal points, SLR full-rate, and LLR normal points), information about these data, and products derived from these data.

SYSTEM DESCRIPTION

The CDDIS archive of laser ranging data and products are accessible to the public via anonymous ftp and the WWW at

<ftp://cddisa.gsfc.nasa.gov/pub/slr> and

<ftp://cddisa.gsfc.nasa.gov/pub/reports>

COMPUTER ARCHITECTURE

The CDDIS is operational on a dedicated Compaq/Digital Equipment Corporation (DEC) AlphaServer 4000 running the UNIX operating system. This facility currently has over 300 Gbytes of on-line magnetic disk storage; approximately twenty Gbytes will be devoted to laser ranging activities. The CDDIS is located at NASA's Goddard Space Flight Center (GSFC) in Greenbelt Maryland and is accessible to users 24 hours per day, seven days per week.

STAFFING

Currently, a staff consisting of one NASA civil service employee and three contractor employees with Raytheon Information Technology and Scientific Services (RITSS) supports all CDDIS activities:

- Ms. Carey Noll, CDDIS Manager
- Dr. Maurice Dube, Head, CDDIS contractor staff and senior programmer
- Ms. Ruth Kennard, request coordinator
- Ms. Laurie Batchelor, data technician

ARCHIVE CONTENT

SLR Data

The CDDIS receives on-site normal point data on a daily basis from two sources: the NASA operations center managed by Honeywell Technical Services, Inc. (HTSI) and the EUROLAS data center (EDC) at the Deutsches Geodätisches Forschungsinstitut (DGFI) in Munich, Germany. Both sources deposit their data files to their individual user accounts on the CDDIS computer. EDC deposits a single file containing all data from all satellites tracked by over twenty stations in EUROLAS and the WPLTN and transmitted to their data center in the last 24-hour period. HTSI receives data from the seven NASA and NASA-partnership stations as well as seven other global stations each day. HTSI also retrieves the single file deposited by EDC at the CDDIS. The data from these two sources are then merged and compiled into several daily files, one containing data received at HTSI in the last 24 hours, one containing these data as well as data sent by EDC, and individual files by satellite, each also containing all data received in the last 24 hours. These three types of files containing normal point data are then transmitted to the CDDIS and are available to the user community. The data are in the ILRS normal point format and stored in uncompressed ASCII files.

The CDDIS staff has created automated routines that peruse the accounts of the two sources of laser data and copy new files to the public disk areas. The content and structure of the ILRS global data center at the CDDIS is shown in Table 6.1.1-1 below. Data are archived in daily files where each file contains all data received at the operations and other global data centers within the last 24 hour period. Thus, a daily file could contain data recorded any time 24 hours prior to the date. Typically, the file contains data from the previous one to two days. However, at times laser stations transmit data several days or weeks old that have been corrected or recently checked for quality. Since the date in the file name does not reflect the date of the data itself, the CDDIS staff create merged, time-sorted files containing a month of data. These files are stored in the satellite-specific subdirectories by year and are created about thirty days after the end of the month. This delay ensures that nearly all of the month's data is captured.

Directory	File Name	Description
Data Directories		
slr/slrql/allsat/yyyy	all_qlyymmdd.all	SLR on-site normal point data files for all satellites and stations, year <i>yyyy</i> or <i>yy</i> , month <i>mm</i> , and day <i>dd</i>
	nasa_qlyymmdd.dat	SLR on-site normal point data files for all satellites and NASA stations only, year <i>yyyy</i> or <i>yy</i> , month <i>mm</i> , and day <i>dd</i>
	ql_allsat_yymmdd	SLR on-site normal point data files for all satellites and EDC stations only, year <i>yyyy</i> or <i>yy</i> , month <i>mm</i> , and day <i>dd</i>
slr/slrql/satname/yyyy	new_qlyymmdd.sat	SLR on-site normal point data files for satellite <i>satname</i> or <i>sat</i> , year <i>yyyy</i> or <i>yy</i> , month <i>mm</i> , and day <i>dd</i>
slr/slrft/satname/yyyy	satname_ver.yymm.Z	Monthly SLR full-rate data files for satellite <i>satname</i> and year <i>yyyy</i> or <i>yy</i> , month <i>mm</i> , and version <i>ver</i>
slr/slrft/satname/yyyy/daily/ssss	ssss_yymmdd_ver.satname.Z	Daily SLR full-rate data files for satellite <i>satname</i> , year <i>yyyy</i> and station <i>ssss</i> or <i>yy</i> , month <i>mm</i> , day <i>dd</i> , and version <i>ver</i>
slr/slrnpt/satname/yyyy	satname_ver.yymm.Z	Monthly SLR normal point data files derived from full-rate data for satellite <i>satname</i> and year <i>yyyy</i> or <i>yy</i> , month <i>mm</i> , and version <i>ver</i>
slr/llrnt/yyyy	llr_npt.yymm.Z	Monthly LLR normal point data files for year <i>yyyy</i> or <i>yy</i> , and month <i>mm</i>
Other Directories		
pub/reports/slrweek/yy	slrql_week.sdate_edate slrql_week.yymm	Weekly SLR data reports for year <i>yyyy</i> or <i>yy</i> and start date <i>sdate</i> and end date <i>edate</i> or month <i>mm</i>
pub/predicts/satname	satname_ephemerisno_ yymmdd.source	Daily SLR satellite prediction files for the current year for satellite <i>satname</i> and source <i>source</i>
pub/predicts/yyyy	satname_ephemeris_yyyy. source	Yearly SLR satellite prediction files for year <i>yyyy</i> and source <i>source</i>
pub/reports/slrmail	slrmail.####	SLRMail archive, message number ####

Table 6.1.1-1. CDDIS Directory Structure for ILRS Data and Information

During 1999, all LLR stations began transmitting lunar laser data in the ILRS normal point format for inclusion in the data stream already established for SLR data. Therefore, lunar and satellite laser ranging data are available in the daily files discussed above.

In addition to normal point data, the CDDIS receives full-rate data from a subset of the global tracking network. Since full-rate data is a minimally supported product within the ILRS, many stations do not transmit these data. The NASA operations center transmits full-rate data from several stations to the CDDIS on a daily basis; these data are archived by satellite and station. If available, the CDDIS retrieves any full-rate data archived at EDC and creates merged files on a monthly basis for each satellite. At this time, the individual daily satellite files of full-rate data are removed from the public archive.

SLR Products

During 1999, the CDDIS archived SLR product files for an ILRS Analysis Working Group pilot project to compare individual analysis center solutions of station positions and Earth orientation parameters. These solutions were deposited to the CDDIS by the Analysis Centers and copied to public disk areas within the SLR data directories. This procedure will serve as a test for future routine submission of laser data solutions.

Supporting Information

The CDDIS anonymous ftp archive and web site provides access to many types of ancillary data used with laser ranging data. This information includes site occupation histories, coordinates, and eccentricities, SLR satellite prediction and time bias files, format documents, SLR data reports (quantity and quality), and historic SLRMail messages. These files are updated as new information is received via e-mail, ftp, etc. from the global SLR community.

ILRS WEB SITE

Since the ILRS Central Bureau and the CDDIS are both located within the Laboratory for Terrestrial Physics at NASA GSFC, the CDDIS computer facility hosts the ILRS web site. An alias for host *cddisa.gsfc.nasa.gov*, *ilrs.gsfc.nasa.gov*, was established for the ILRS web site. Thus, users can view the central ILRS web site at:

<http://ilrs.gsfc.nasa.gov>

More details on the web site can be found in the Central Bureau section of this annual report (see Section 2).

FUTURE PLANS

The ILRS is looking to standardize the data products available through the global data centers. Therefore, the CDDIS, in conjunction with the EDC, will study ways to archive data in a common directory structure and file naming convention. This commonality will ensure a way for users to retrieve data from either data center with a minimal amount of change to existing data download scripts. In addition, some SLR missions will require a more frequent distribution of data since a daily update of the satellite orbit may not be sufficient. The CDDIS and EDC staff will study the impact of this requirement on the ILRS data flow and develop plans for handling these data, reducing the latency and increasing the frequency of data availability at their respective archives.

Various SLR missions now require satellite prediction information more often than the standard weekly product. Therefore, operations centers supporting the ILRS are planning to issue SLR satellite prediction files on a daily basis. The ILRS global data centers will make these files available and retain them for approximately one month. The daily files will then be merged into monthly prediction files and eventually yearly prediction files to reduce the number of individual files archived.

CONTACT INFORMATION

To obtain more information about the CDDIS archive of ILRS data and products, contact:

Ms. Carey E. Noll	Phone: (301) 614-6542
Manager, CDDIS	Fax: (301) 614-5970
Code 920.1	E-mail: noll@cddis.gsfc.nasa.gov
NASA GSFC	WWW: http://cddisa.gsfc.nasa.gov/cddis_welcome.html
Greenbelt, MD 20771	
USA	

6.1.2 EDC REPORT

Wolfgang Seemueller, *Deutsches Geodatisches Forschungs Institut*

INTRODUCTION

EDC was founded in August 1991 by an agreement between the Consortium of European Satellite Laser Ranging Stations and DGFI. In November 1998, the International Laser Ranging Service (ILRS) began operations, with all its permanent components. Two global ILRS data centers, CDDIS/NASA and EDC/DGFI, and one regional data center in Shanghai for the Asian region were established. Their functions are described in the terms of reference of the ILRS. In general, the global ILRS data centers are responsible for archiving and distributing laser observation data, ancillary data and all other relevant information, as well as ILRS products.

FUNCTIONS PROVIDED

Functions provided are:

- automatic archive and distribution of recently-delivered data (at least once per day)
- providing the observation data to all users at a public ftp server
- running SLRMAIL, SLREPORT, and SLRTBF email exploders
- archiving and distribution of IRVs of all satellites
- automatic processing to archive and provide SLR station change and configuration log files
- mirror of the ILRS web pages at EDC
- providing web pages of EDC in the DGFI Information System GeodIS
- special services for data delivery on request

BACKGROUND

In the late 1990's the European Satellite Laser Ranging stations had a great interest in the establishment of a data center for the EUROLAS network to take over the data archiving and distribution as well as the communication between the SLR stations and data/analysis centers. DGFI proposed to EUROLAS to operate the EUROLAS Data Center (EDC). Because of its demonstrated capabilities to collect and

disseminate large space geodetic data volumes (FR data) and to communicate via international communication links, the EDC at DGFI was accepted by EUROLAS in August 1991. An agreement specifies the arrangements agreed upon on the basis of which the EDC will be organized and operated. Figure 6.1.2-1 shows the EUROLAS SLR stations within the ILRS network.

Until recently, the on-site normal points from Western Pacific Laser Tracking Network (WPLTN) stations for the satellites ERS-1 and ERS-2 (and GFZ-1) operated by GFZ Potsdam were also sent to EDC. After the formation of the WPLTN, all stations were asked to send their data to the data center of their choice, but only to one. Therefore, the Russian stations operated by the Mission Control Center (MCC) in Moscow send their data to the EDC while other stations send their data to either the EDC or CDDIS (see data flow chart in the Data Center Reports Introduction, Section 6).

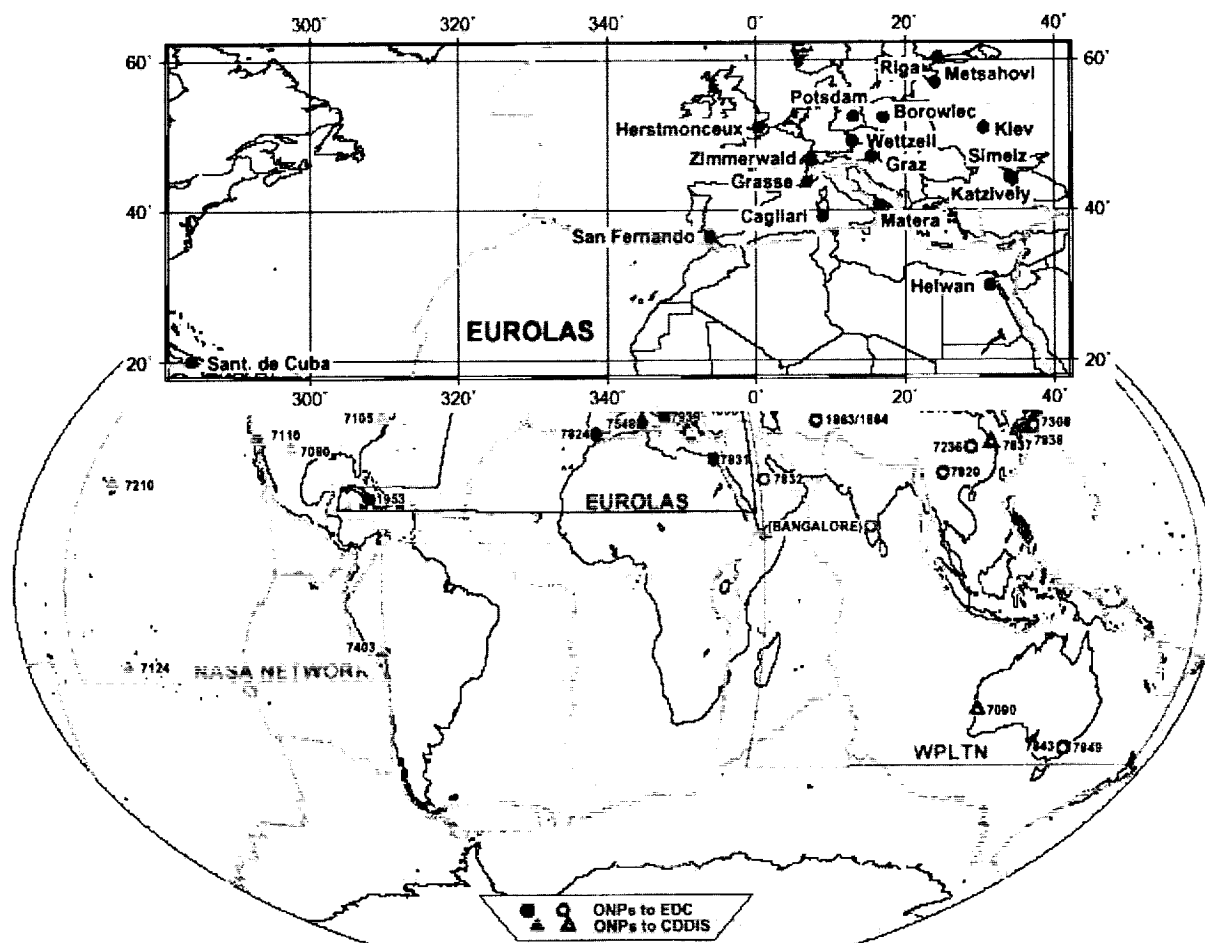

Figure 6.1.2-1 EUROLAS Stations within the Global ILRS Network

FACILITIES/SYSTEMS/CURRENT STATUS

Machine:	Pentium Pro 200, 128 Mbyte
Operating System:	LINUX
Storage space:	10 GigaByte
Backup facilities:	IBM ADSTAR Distributed Storage Manager (1000 TerraByte) Mirror of the EDC machine to a second similar machine

ARCHIVE CONTENT

Laser observation data for all satellites, in the form of on-site normal points and older full-rate data, are available from the EDC ftp server (or alternatively through the EDC web pages). The table in Section 8.5 shows a report of the data holdings for the year 1999. The summaries per month for all satellites and all SLR stations are available at the EDC ftp server under pub/laser/messages/slreport.

KEY POINTS OF CONTACT

<i>Contact person for EDC:</i>
Wolfgang Seemueller DGFI Marstallplatz 8 D-80539 Muenchen /Germany
<i>Telephone:</i>
+49/089/23031109
<i>Fax:</i>
+49/089/23031240
<i>E-mail:</i>
seemueller@dgfi.badw-muenchen.de edc@dgfi.badw-muenchen.de slrmail@dgfi.badw-muenchen.de slreport@dgfi.badw-muenchen.de slrtbf@dgfi.badw-muenchen.de
<i>Web Page:</i>
http://www.dgfi.badw-muenchen.de/edc/edc.html
<i>FTP:</i>
ftp.dgfi.badw-muenchen.de (anonymous)
<i>ILRS Web Pages (mirror of ILRS Web pages at CDDIS):</i>
http://www.dgfi.badw-muenchen.de/edc/ilrs/ilrs_home.html

FUTURE PLANS

At the ILRS General Meeting in Florence in September 1999 it was recommended to establish the same directory structure at both ILRS Global Data Centers CDDIS and EDC. Therefore the CDDIS and EDC should make arrangements to have the same tree structure at both sites, at least from a specified directory onward. It is also necessary to have a file naming convention inside this structure.

Upcoming Low Earth Orbiting (LEO) satellites will require the implementation of a faster data exchange procedure. The same constraint is valid for the distribution of the IRVs for these satellites.

REFERENCES

For further information, readers are directed to the reports of the former CSTG SLR/LLR Subcommittee Meeting Report and ILRS General Meeting Reports at the ILRS Web pages at:

http://ilrs.gsfc.nasa.gov/ilrs_reports.html and

<http://ilrs.gsfc.nasa.gov/biblio.html>

6.2 REGIONAL DATA CENTERS

6.2.1 SHANGHAI OBSERVATORY DATA CENTER REPORT

Zhang Zhongping, *Shanghai Regional Data Center*

BACKGROUND

The Shanghai Regional Date Center (SRDC) was established in 1991 as an archive for the SLR data obtained by the Chinese SLR stations. It is located at the Center for Astro-Geodynamics Research, Shanghai Observatory, Chinese Academy of Sciences.

SLR full-rate data are available from Shanghai since 1983, Wuhan since 1985, and Changchun since 1987. Prior to August of 1995, the SLR full-rate data from the Chinese SLR stations were sent to the SRDC on floppy disks and were then mailed to the CDDIS or EDC on 1/2 inch tapes by the SRDC once per year. In 1996, the SRDC stopped mailing full-rate tapes to the CDDIS and EDC when the CSTG recommended the discontinuation of full-rate data archiving in favor of on-site normal points. The SRDC continues to archive the full-rate data from five Chinese stations, including Beijing since 1995 and Kunming since 1999.

FACILITIES/SYSTEMS

- Computer: Sun Server 3002
- Operation System: Unix
- Storage space: 30 GB

CURRENT STATUS

The Chinese stations mail their full-rate data to the SRDC once every three months. The SRDC stores these data in MERIT-II format on compact disks, which are openly available to the researchers. The summary of the data of the Chinese SLR stations can be found in Table 6.2.1-1 below and at the address:

<http://center.shao.ac.cn/APSG/Newsletter/index.htm>

KEY POINTS OF CONTACT

Zhang Zhongping, Manager of SRDC

Tan Detong

Tang Wenfang

FUTURE PLANS

The SRDC will be part of the Asia-Pacific Space Geodynamics (APSG) Data Center and will archive the data from all SLR stations in the APSG/WPLTN. The SLR data of the SRDC will be stored on-line for remote access.

	SHANGHAI	WUHAN	CHANGCHUN	BEIJING	KUNMIN	TOTAL
	Pass/obs.	Pass/obs.	Pass/obs.	Pass/obs.	Pass/obs.	Pass/obs.
1983	8/97					
1984	43/707					
1985	2/225	15/1,252				
1986	22/2,972					
1987	76/5,534		3/178			
1988	82/6,800	10/1,731	12/968			
1989	119/7,281	50/7,254				169/14,535
1990	436/ 143,127	121/37,814				558/180,949
1991	403/90,782	140/28,194	49/7,628			591/126,612
1992	538/118,390	288/67,918	309/70,045			1,135/256,353
1993	408/94,841	187/50,035	745/167,229			1,340/312,105
1994	454/157,695	247/66,061	996/195,657	70/15,869		1,767/435,281
1995	591/289,962	118/33,210	948/178,850	356/79,748		2,013/581,770
1996	599/307,202	250/67,916	1,158/357,009	518/75,813		2,525/807,940
1997	1,118/477,652	206/47,919	2,621/1,199,969	1,511/377,501		5,453/2,103,426
1998	883/479,795	191/49,975	2,673/1,005,524	803/226,754		4,550/1,762,048
1999	1,510/1,041,927	68/23,034	2,560/867,861	1,069/339,486	505/488,812	5,644/2,738,086

Table 6.2.1-1. Summary of the Observations of Chinese SLR Network

SECTION 7

ANALYSIS CENTER REPORTS



SECTION 7 - ANALYSIS CENTER REPORTS

The Analysis Centers receive and process information from the Data Centers and regularly make the results of their analysis available to ILRS participants. Standard products are delivered to the Global Data Centers and to the IERS, among other recipients. The Analysis Centers also provide a level of quality assurance on the global data set by monitoring individual station performance via the fitted orbits used in generating the quick-look science results. The interval and time lag for product delivery specified by the Governing Board determines the credential as Analysis or Associate Analysis Center, and three institutions currently qualify as Analysis Centers.

CSR at the University of Texas monitors and disseminates results on LAGEOS-1 and LAGEOS-2 analysis on a weekly basis. This information is also accessible, together with CSR 3-day EOP values via the web and anonymous ftp. NASA uses the EOP information for the operational orbit determination for TOPEX/Poseidon. CSR also provides evaluation and technical support of new systems in engineering status and supports the determination of the ITRF through the submission of annual SLR tracking station position and velocity solutions.

Delft University of Technology's QLDAC also provides a semi real-time quality control of observations on LAGEOS-1 and LAGEOS-2, and reports to the stations on a regular basis to assist in monitoring the performance of operational systems, as well as for technical support of systems in engineering status. QLDAC also produces accurate EOPs for inclusion in the USNO/IERS bulletins, and provides information for scientific interpretation and for the motivation of data analysis.

Moscow's MCC provides regular daily values of polar motion and length-of-day, and adds GLONASS analysis to its bulletins of Lageos-1 and Lageos-2 SLR station data performance, as well as producing precise orbits for GLONASS and Westpac orbits and other low satellites.

Associate Analysis Centers provide a variety of capabilities to supplement the products of the main Analysis Centers. For example, the Norwegian Defence Research Establishment's FFI, which is also an IVS Analysis Center, offers the capability to combine VLBI, GPS, and SLR data at the observation level. The DGFI in Munich focuses on the automation of the SLR data analysis in its plans to establish an operational analysis center and on the computation of a global SLR solution for the ITRF2000. The prediction and quality control work at the NERC SLR facility at Herstmonceux and Monks Wood, UK was developed to better equip the SLR system, and the wide use of these products within the ILRS network is a valuable spin-off from the work. The Italian Space Agency's CGS provides standard, special and multi-technique analysis products. The standard products are routinely distributed to the IERS and include the coordinates and velocity field of the SLR network and EOP values provided yearly, as well as monthly EOP to contribute to the Bulletin B distributed to the scientific community. Special and the multi-technique products include precise orbit determination for Lageos I, Lageos II, Starlette, Stella and ERS-1, with supporting data interpretation, and time series of low degree geopotential coefficients and geocenter motion, supported by inter-technique combination and comparison.

The GFZ in Potsdam complements its operation of the local SLR station with the routine generation and distribution of IRVs and two-line elements for ERS-1, ERS-2 and GFZ-1 and continuously monitors the predictions. GFZ has also contributed to the Earth gravity field, station position and velocity model GRIM5, jointly with GRGS/CNES. The AUSLIG Space Geodesy Analysis Center in Canberra is participating in the ILRS Analysis Working Group pilot projects for station coordinates and EOPs, orbit comparison and the software/standards comparison. AUSLIG also continues to submit results to the IERS Time Series Pilot Project, and will contribute a significant SLR solution to the ITRF2000. In Grasse, CERGA's data analysis of LAGEOS observations, permanent GPS receiver measurements, and

absolute gravimetry measurements has led to improvements in orbitography and positioning quality control. In particular, this analysis has allowed an accurate calibration of the Grasse Lunar Laser Ranging station. The group at JCET/GSFC in Greenbelt, Maryland continues to generate weekly solutions as a contribution to the IERS/ITRF Pilot Project for monitoring the episodic and seasonal variations in the definition of the geocenter, and is also re-generating weekly SINEX following ILRS-adopted standards.

The Russian Academy of Science's IAA Associate Analysis Center continues to regularly submit EOP operational and final solutions to the IERS. IAA is also developing software for the combination of SLR, GPS and VLBI EOP series, for combined processing of the SLR and VLBI observations, and for processing of the microwave and laser range observations of GPS and GLONASS satellites. The CODE group at the Astronomical Institute of the University of Berne has set up the SLR-GPS Quick-look Service to monitor the SLR observations using IGS rapid and final orbits. These are available only 12 hours after the end of the observation day and thus provide the possibility to give very rapid feedback on the quality of the SLR observations. Potsdam's BKG provides station coordinates, velocities and EOPs to the IERS on an annual basis, and has developed a system providing solutions which are not constrained by fixing parameters but by using a-priori sigmas to introduce the datum. The BKG also joins the other Analysis Centers and Associate Analysis Centers in contributing to the ILRS Analysis Working Group pilot projects for improving station coordinates and EOPs.

7.1 SATELLITE LASER RANGING

The Analysis Centers fall into three categories: Analysis Centers, Associate Analysis Centers and Lunar Analysis Centers.

7.1.1 ANALYSIS CENTERS

The Analysis Centers receive and process tracking data from one or more data centers for the purpose of producing ILRS products. The Analysis Centers are committed to produce the products, without interruption, at an interval and with a time lag specified by the Governing Board to meet ILRS requirements. The products are delivered to the Global Data Centers, to the IERS (as per bilateral agreements), and to other bodies, using designated standards. At a minimum, the Analysis Centers must process the global LAGEOS-1 and -2 data sets and are encouraged to include other geodetic satellites in their solutions. The Analysis Centers provide, at a minimum, Earth orientation parameters on a weekly or sub-weekly basis, as well as other products, such as station coordinate, on a monthly or quarterly basis or as otherwise required by the IERS. The Analysis Centers also provide a second level of quality assurance on the global data set by monitoring individual station range and time biases via the fitted orbits (primarily the LAGEOS-1 and -2 satellites) used in generating the quick-look science results.

7.1.1.1 Center for Space Research

Richard Eanes and John Ries, *Center for Space Research, University of Texas*

INTRODUCTION / DATA PRODUCTS PROVIDED

Researchers at The University of Texas at Austin have analyzed SLR data since about 1974 when the UTOPIA orbit determination software was developed and applied to the determination of baseline lengths using Beacon-Explorer-C tracking obtained by stations deployed by GSFC in various locations, most notably in San Diego and Quincy, California which span the San Andreas fault. The UTOPIA software was soon applied to the Geos-3 SLR tracking to support this pioneering satellite altimeter mission and to make our first polar motion determinations (Schutz et al., 1979). When Starlette and LAGEOS-1 were launched, the SLR tracking of these first "cannonball" targets was applied to gravity field research and towards improvements in the techniques used for precise orbit determination. As the number, distribution and accuracy of the global network improved, the challenge of modeling increased and the number of applications grew. This process continues today even as RMS fits to the SLR tracking of LAGEOS have shrunk to the sub-centimeter level.

The operational analysis at UT/CSR includes the following activities:

- (i) The quality of observations on LAGEOS-1 and LAGEOS-2, taken by the global network of SLR stations, are monitored on a weekly basis. Every Tuesday, the analysis is performed and the results are disseminated to the SLR stations and other institutions. The analysis covers the observations taken during the week prior to the date of the computations, so that the quality assessment lags the actual data collection by somewhere between 3 and 10 days. The observed biases, time biases and noise levels are determined for each pass from every station. The results are reported through the web at <http://www.csr.utexas.edu/slr/>.
- (ii) As part of the LAGEOS analysis, 3-day Earth Orientation Parameters (EOPs) are estimated, with NAVNET VLBI used for long term UT1, for inclusion in the USNO/IERS bulletins. These results are also available via the web and anonymous ftp. These EOP values are used by NASA for the operational orbit determination for the TOPEX/Poseidon (T/P) altimeter satellite and for the creation of the T/P altimeter Geophysical Data Records (GDR).
- (iii) Evaluation and technical support of new systems in engineering status is provided.
- (iv) The determination of the International Terrestrial Reference System (ITRF) is supported through the submission of annual SLR tracking station position and velocity solutions.
- (v) Preliminary information for scientific data analyses are also provided, such as high precision satellite orbits and preliminary coordinates for new stations.

FACILITIES/SYSTEMS

The University of Texas Center for Space Research occupies 23,000 sq-ft of office and laboratory space. CSR also maintains a variety of computers and other scientific equipment. The computer assets include an Origin 2000 server managing 6 TB of archival storage, as well as a variety of workstations and PCs. CSR has recently acquired a Cray SV1-1A supercomputer that is operated jointly with UT's Texas Advanced Computation Center. The SV1-1A has 16 1.2 GFLOP processors, 16 GBytes memory, and 4 fiber channel RAID drive arrays (with 640 GB of disk total). UT provides operational support for the SV1-1A as well as a file system and data migration facility supported by a four-processor SGI Origin 2000 server with approximately 800 GB of on-line storage and 30 TB of tape archive.

CURRENT ACTIVITIES

Weekly EOP estimation and SLR Network Quality Control

Typically, the observations are taken from NASA's Crustal Dynamics Data Information System (CDDIS), then merged, time-sorted and edited for double entries. The main element of the weekly analysis is the fitting of 3-day continuous orbits through the last 12-18 days of observations. A summary of the computation model currently in use is given in Table 7.1.1.1-1. The fitting results in an average value for the weighted rms-of-fit of 15-20 mm. Table 7.1.1.1-2 shows the results obtained for a recent 18-day span based on the 3-day arcs, 3-day EOP and linearly-varying coordinates used in the weekly analysis. Clearly visible is the variety in the post-fit residuals between the various stations.

Seasonal Variations of the Earth's Gravity Field

Mass redistributes itself in the Earth system on a variety of temporal and spatial scales reflecting complex interrelated processes in the oceans, atmosphere, groundwater, glacial/polar ice, among others. The measurement of these variations is thus important for a variety of studies attempting to understand the interrelations of the different components of the Earth system, and how they may change with time due to anthropogenic influences. We have used LAGEOS-1 and LAGEOS-2 laser ranging data to determine long wavelength seasonal variations of the Earth's gravity field from 1993 to the present. Due to the altitude of these satellites, and the non-continuous nature of the measurements, these data can detect seasonal gravitational variations only for wavelengths of roughly 10,000 km and longer (a degree 4 spherical harmonic expansion). We have compared the observed annual variations for a complete 4 x 4 spherical harmonic expansion as observed by LAGEOS 1/2 SLR data to those predicted from a variety of atmospheric, oceanic, and hydrologic models. We have used the observed variations to optimally select the best set of model predictions. The correlation of the maps of the observed and modeled annual geoid variation is as high as 0.8, with an rms difference of close to 1 mm. Given the sparse temporal and spatial distribution of the SLR data, and the limitations of the geophysical models, we consider this agreement to be as good as can be expected (Chen et al., 1999; Nerem et al., 2000). To further enhance the resolution of the time-variable gravity field (up to degree 6 or more), SLR from T/P, Ajisai and Stella have been analyzed (Cheng et al., 1999), and the recent tracking campaign for the BEC satellite may help further resolve the various coefficients.

Utilized in LAGEOS-1 and LAGEOS-2 SLR Analysis	
Reference Frame	
Conventional Inertial System (CIS)	J2000
Precession	1976 IAU
Nutation	IERS-96
Planetary Ephemerides	JPL DE-200
Conventional Terrestrial System	CSR95L01 (new stations adjusted)
Polar Motion	EOP estimated every 3 days (IERS a priori)
Reference Ellipsoid	$a_e = 6378136.3 \text{ m}$ $1/f = 298.257$
GM	$GM = 398600.4415 \text{ km}^3\text{s}^{-2}$
Observation models	
Source	Collected from CDDIS
Center of Mass offset	251 mm
Elevation Cutoff	10 degrees
Troposphere	Marini-Murray model
Rotational Deformation	IERS-96
Ocean Loading	IERS-96
Relativity	IERS-96
Atmosphere Loading	not modeled
Observation Weighting	Station dependent (precision plus overall modeling uncertainty)
Force Models	
Gravity Model	IERS-96 (JGM-3)
Temporal Gravity	$J_2\text{-dot} = -2.6 \times 10^{-11}/\text{yr}$ Epoch 1986.0
N-Body	DE-200 (Sun, Moon and planets)
Solid Earth Tides	IERS-96
Ocean Tides	CSR 3.0
Rotational Deformation	IERS-96
Relativity	Central Body (Earth)
Solar Radiation Pressure	Cr for LAGEOS-1 fixed at .1125, LAGEOS-2 fixed at .125
Earth Radiation Pressure	Albedo/Infrared
Numerical Integration	Cowell 14th order; step-size 300 sec (298 sec for LAGEOS-2)
Empirical Accelerations	1 constant along-track, 1 1-cpr along-track and cross-track
Arc Length	3 days

Table 7.1.1-1. Reference Frame and Force Models UT/CSR computation model summary.

Station	number of obs	mean (mm)	rms (mm)	precision (mm)
Maidanak, Uzbekistan	59	-49	51	13
Riga, Latvia	49	-2	22	9
Kazivili, Ukraine	33	12	30	9
McDonald Observatory, Texas	106	-9	12	2
Yarragadee, Australia	163	-4	14	2
Greenbelt, Maryland	102	3	11	4
Monument Peak, California	360	-1	17	2
Wuhan, China	136	-2	29	9
Changchun, China	121	7	16	10
Arequipa, Peru	54	-15	23	7
Cagliari, Italy	50	-28	50	9
Zimmerwald, Switzerland	311	-8	16	5
Borowiec, Poland	89	-6	18	5
Kunming, China	27	--	--	--
San Fernando, Spain	183	-49	50	7
Helwan, Egypt	18	9	19	6
Grasse, France (7835)	305	5	10	2
Potsdam, Germany	94	10	17	4
Shanghai, China	7	--	--	--
Simosato, Japan	14	-12	11	6
Graz, Austria	339	-9	14	2
Herstmonceux, United Kingdom	186	-13	20	3
Grasse, France (7845)	193	1	14	4
Mount Stromlo, Australia	279	-16	20	4
Matera, Italy	76	-6	40	19
Wetzell, Germany	249	-17	27	6
Totals (weighted)	3603	-5	16	4

-- all data edited

Table 7.1.1.1-2. Example of analysis results for LAGEOS-2: the number of normal points, the mean and rms of the post-fit residuals and the estimated precision for the period June 17–July 5, 2000.

GPS/GLONASS Orbit Analyses

The Center for Space Research contributed to the International GLONASS Experiment 98 (IGEX-98) campaign through the evaluation of GLONASS orbits computed by different centers using Satellite Laser Ranging (SLR) data and through the computation of GLONASS orbits using SLR data and the CSR's UTOPIA software. When used directly to compute range residuals relative to each center's radiometric orbit, we find the SLR data to be a very effective discriminator of the radial orbit accuracy. We also find that the mean of the SLR range residuals has a value of -5 cm, similar to what has been observed in SLR/GPS comparisons. This implies the presence of a mean radial acceleration of 4–5 nm/s² (we consider it unlikely that an error in GM could account for more than a small part of this), or there is a systematic error in both the GPS and GLONASS center-of-mass offset corrections (Eanes et al., 1999) caused by effect of target signature on the ranging data from systems operating at different return signal strengths.

Precision Orbit Determination and Verification

SLR and DORIS tracking provide the principal means of precise orbit determination for the T/P altimeter spacecraft, supporting an orbit accuracy of 2 to 2.5 cm in the radial direction (Ries and Tapley, 1999). Studies have demonstrated that the DORIS data are providing the dominant contribution to the overall orbit accuracy, but it was also apparent that the variations in the centering of the orbit from cycle to cycle in the Z direction (along the Earth's spin axis) increased significantly when the SLR data were excluded. This centering is critical to avoid artificial signals in the observed sea surface variations between the hemispheres that might be erroneously interpreted. The SLR data, due to the absolute ranging information that they provide, help to center the orbit more precisely and consistently, as well as contribute to the overall orbit accuracy. They also provide an unambiguous determination of the height of the spacecraft above a tracking station, particularly for passes which cross at a high elevation angle. This capability is unique to SLR, and it is crucial for orbit accuracy assessment at the current levels. It is clear that the SLR data are an important component of the tracking system. The two systems have also provided invaluable redundancy, since each system has experienced periods of reduced or interrupted tracking.

Geocenter

SLR analyses have shown that the coordinate frame of tracking stations attached to the Earth's crust moves detectably relative to the Earth's center of mass. This translational motion, when viewed from a crust-fixed frame, is known as "geocenter motion" and is caused by the mass movement of planetary fluids, primarily the atmosphere and oceans. Observing the geocenter motion at seasonal and interannual time scales can provide important constraints on the mass transport within the Earth system. Two geocenter time series, one based on LAGEOS-1/2 and one on T/P, are shown in Figure 7.1.1.1-1. The geocenter coordinates have been derived from the translational offsets of monthly solutions with respect to a multi-year mean solution. There is fairly good coherence between the two series for the X and Y components. For the Z component, agreement is less good, and the seasonal variation is not as clear.

GM and Terrestrial Reference Frame Scale

We continue to try to refine the estimation of the Earth's gravitational coefficient (GM), which is best determined by laser ranging data to geodetic satellites. The current determination was based primarily on SLR tracking to LAGEOS-1, and the principal contributions to the uncertainty of the solution (~2 ppb) was determined to be possible biases (both constant and frequency-dependent) in the ranging data as well as a possible bias in the standard Marini-Murray tropospheric refraction model (Ries et al., 1992). A truly complete solution for GM, with an uncertainty estimate that adequately reflects the various sources of systematic error, requires the simultaneous adjustment of the station coordinates, the range biases, and the satellite orbits, as well as the refraction model bias and possibly even satellite center-of-mass offset biases. Such a solution is singular unless satellites at significantly different heights are used. The current estimate for GM is based primarily on Lageos-1, so not all of these parameters could be adjusted. Consequently, it was necessary to consider their contribution as part of the error estimate of 2 ppb. Preliminary results using several satellites (LAGEOS-1/2, Ajisai, Stella, and T/P) do indicate the probability of a few mm bias in the refraction model. Efforts in this area are ongoing in an attempt to reduce the uncertainty in the estimate for GM, and consequently the uncertainty in the SLR determination of the scale of the terrestrial reference frame, to 1 ppb or better. A reduction in the scale uncertainty to less than 0.5 ppb would be particularly valuable, as there are questions at the 0.7 to 1.4 ppb level regarding the scale factor between VLBI, GPS and SLR determinations of the terrestrial reference frame.

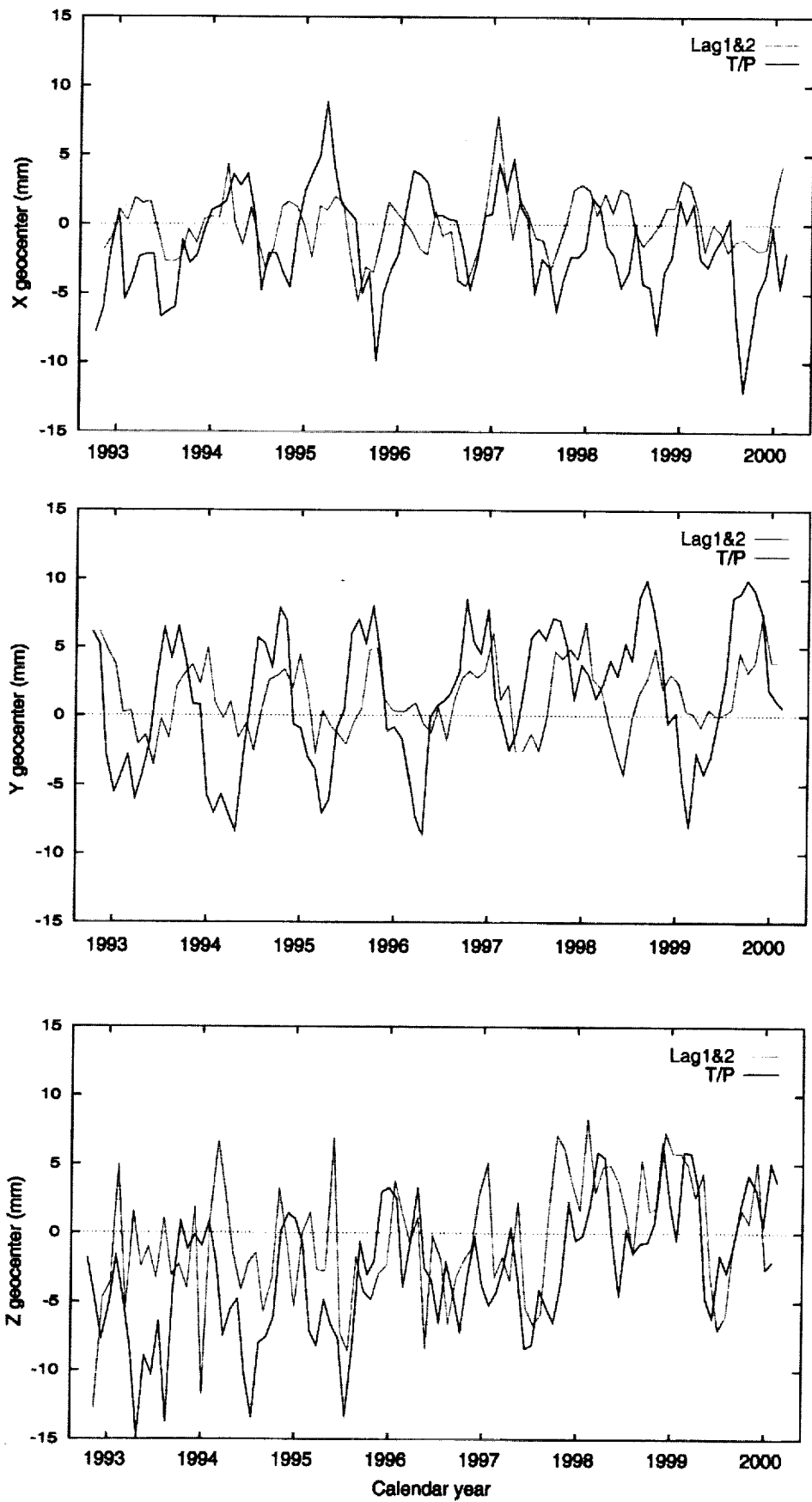

Figure 7.1.1.1-1 Geocenter motion determined by LAGEOS-1/2 and TOPEX/POSEIDON

OUTLOOK FOR THE FUTURE

In order to improve the quality of the analysis, UT/CSR intends to introduce a new model for station coordinates based on a joint SLR and DORIS solution from LAGEOS1, LAGEOS2 and T/P. The model which is currently in use was computed in 1995. Models for ocean loading are already part of the analysis, but the effect of atmospheric pressure loading deformation is not yet included in the operational analysis. We will continue to explore the application of multi-satellite analysis to the question of quality control for the SLR network. The question of sub-cm systematic errors in the Marini-Murray refraction model is being investigated. In addition, the analysis system needs to be automated more than is the case in the current situation. UT/CSR will strive for a continuous improvement in order to serve the SLR community as well as possible.

ANALYSIS WORKING GROUP MEMBERS

Richard Eanes, Minkang Cheng, Rick Pastor, John Ries, Bob Schutz

REFERENCES

- Chen, J. L., C. R. Wilson, B. D. Tapley and R. J. Eanes, Low-degree gravitational changes from Earth rotational variations, submitted to *J. Geophys. Res.*, 1999.
- Cheng, M. K. and B. D. Tapley, Seasonal variations in low degree zonal harmonics of the Earth's gravity field from satellite laser ranging observations, *J. Geophys. Res.*, 104(B2), 2667-2681, 1999.
- Eanes, R. J., R. S. Nerem, P. A. M. Abusali, W. Bamford, K. Key, J. C. Ries, and B. E. Schutz, GLONASS orbit determination at the Center for Space Research, proc. International GLONASS Experiment (IGEX-98) Workshop, Nashville, Tennessee, September 13-14, 1999.
- Nerem, R. S., R. J. Eanes, J. C. Ries, and G. T. Mitchum, The use of a precise reference frame in sea level change studies, proc. International Association of Geodesy Conference "Integrated Global Geodetic Observing System", Munich, October 5-9, 1998.
- Nerem, R. S., R. J. Eanes, P. F. Thompson, and J. L. Chen, Observations of annual variations of the Earth's gravitational field using satellite laser ranging and geophysical models, *Geophys. Res. Lett.*, 27(12), 1783-1786, 2000.
- Ries, J. C., R. J. Eanes, C. K. Shum, and M. M. Watkins, Progress in the determination of the gravitational coefficient of the Earth, *Geophys. Res. Lett.*, 19(6), 529-531, 1992.
- Ries, J. C., and B. D. Tapley, Centimeter level orbit determination for the TOPEX/POSEIDON altimeter satellite, Paper AAS 99-142, proc. AAS/AIAA Spaceflight Mechanics Meeting, Breckenridge, CO, February 7-10, 1999.
- Schutz, B. E., B. D. Tapley, J. C. Ries, and R. J. Eanes, Polar motion results from GEOS-3 laser ranging, *J. Geophys. Res.*, 84(B8), 1979..

7.1.1.2 Delft Analysis Center

Ron Noomen, *Analysis WG Coordinator, the Netherlands*

BACKGROUND

The Quick-Look Data Analysis Center (QLDAC) has been operational at Delft University of Technology since the beginning of 1986. Originally organized to support the observational campaigns of the WEGENER-MEDLAS Project (with short occupations of sites in the Mediterranean area by mobile Satellite Laser Ranging (SLR) equipment and a clear necessity for rapid performance feedback) QLDAC has evolved into a service for the entire network of SLR stations. Over time, operations by mobile laser systems have become rare, but the need for rapid-turnaround quality control (QC) results and productivity parameters continues at a slightly more relaxed rate.

Today QLDAC provides the following services:

- (i) near real-time quality control of observations on LAGEOS-1 and LAGEOS-2, taken by the global network of SLR stations. The results are reported to the stations on a regular basis, and are used for monitoring the performance of the systems.
- (ii) production of highly accurate Earth Orientation Parameters (EOPs), for inclusion in the USNO/IERS bulletins.
- (iii) evaluation and technical support of (new) systems in engineering status.
- (iv) provision of preliminary information for scientific data analyses (e.g. satellite orbits, station coordinates, etc.).
- (v) motivation of the data analysts.

Many of the goals mentioned here are or will be worked on in coordination with the International Laser Ranging Service (ILRS).

STATUS

Currently, the computations are performed on a weekly basis. Every Tuesday, the analysis is performed and the results are disseminated to the SLR stations and other interested people. Each analysis basically covers the observations taken during the week prior to the date of the computations, as the QC lags the actual data taking by somewhere between 3 and 10 days.

DEVELOPMENTS IN 1999

To best serve the needs of quality control, QLDAC continuously strives for improvements in the procedures, strategies and models to better simulate the physical truth (i.e. model the satellite orbit and the dynamics of the Earth). However, practical and operational issues limit the amount of effort that can be spent here. Manpower is a very practical limit for such developments: typically, QLDAC can spend about 2 man-days on operational analysis and development work per week. As for operational constraints: changes in the analysis procedure or models can be expected to introduce sudden shifts in the analysis results, albeit in post-fit residuals (measurement systematics), in EOP solutions, or in other elements. Stability of the system will serve the customers better than continuous modifications.

Therefore, significant changes are typically planned ahead and are introduced at one single epoch. In 1999, developments were mainly in the representation of the analysis results. In particular, the weekly report was fine-tuned for customer purposes several times (a completely new layout was introduced at the end of 1998), and preparatory work was performed to make the results available on the Internet. The latter activity is not finalized yet, but is expected to come on line in early 2000. Also, the system was checked for potential Y2K problems and adjusted where necessary.

OPERATIONS IN 1999

As can be expected from a service, QLDAC operated routinely in 1999. An overview of the LAGEOS-1 and -2 passes that were processed is given in Figure 7.1.1.2-1. Typically, the observations are taken from the data centers at NASA's Crustal Dynamics Data Information System (CDDIS) and the EUROLAS Data Center (EDC), merged, time-sorted and edited for double entries. On average, the global network produced about 120 and 100 passes for LAGEOS-1 and -2 per week, respectively.

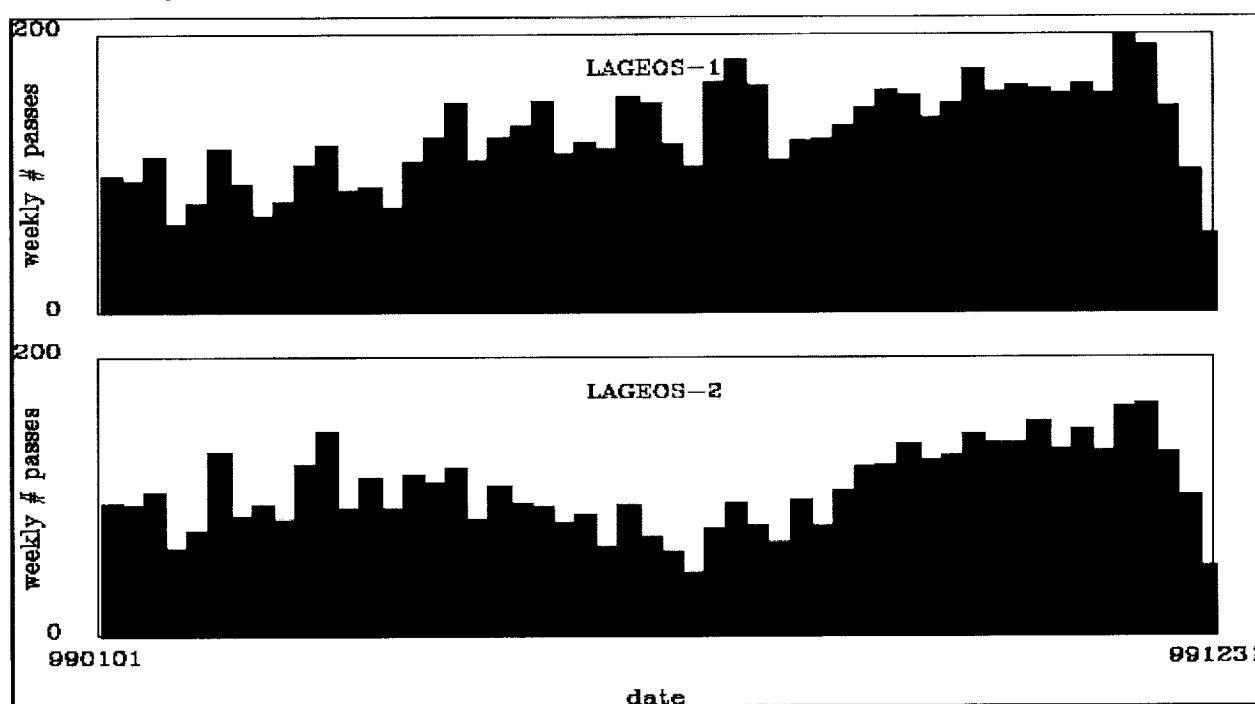

Figure 7.1.1.2-1. Overview of the weekly number of passes per week of LAGEOS-1 and LAGEOS-2 that were acquired by the global network of SLR stations.

The main element of the weekly analysis is the fitting of a 10-day continuous orbit through 10 days of global observations. Typically, such a data arc starts on Thursday, 00:00 hours, and ends on Saturday evening 24:00 hours. A summary of the computation model currently in use is given in Table 7.1.1.2-1.

The fitting processing results in a value for the weighted rms-of-fit of about 0.9 on average. An overview of the corresponding rms-of-fit is given in Figure 7.1.1.2-2, which shows that QLDAC achieves a value of about 40 mm on average. It must be stressed here that this rms-of-fit is not the parameter which is minimized in the estimation process: differences in quality of observations will be compensated for by assigning different values for the weights of the observations in the analysis. Table 7.1.1.2-2 gives a good impression of this: it shows the results obtained for a 10-day data arc at the end of October 1999. Clearly visible is the variety in post-fit residuals (realistic rms values range between 16 and 97 mm), but generally these individual numbers follow the corresponding weights which are given in the final col-

umn). The overall rms-of-fit (again, not the parameter which is minimized) amounts to 36 mm for this arc.

Observations

- collected from CDDIS and EDC;
 - center-of-mass 251 mm;
 - Marini-Murray model for troposphere;
 - elevation cutoff 20 degrees;
 - data weighting root-summed-square of single-shot precision and overall model uncertainty;
 - relativistic effects not modeled;
 - 3.5-sigma data editing.
-

Dynamics

- NASA/CSR JGM-2 gravity field and tides model;
 - 3rd body attraction of Sun, Venus, Moon, Mars, Jupiter, Saturn;
 - dynamic polar motion;
 - direct solar radiation pressure (scaling coefficient kept fixed at 1.13);
 - albedo and thermal radiation of earth not modeled;
 - 1 constant and 2 1-cpr along-track acceleration parameters solved for per satellite and per arc;
 - relativistic effects not modeled.
-

Geometric model

- SSC(DUT) 93L05 model for station coordinates (stations of choice solved for);
 - IERS Bulletin A a priori EOPs (EOPs solved for at 3-day intervals);
 - JPL DE200/LE200 ephemerides;
 - Love model for solid earth deformation;
 - dynamic polar motion;
 - ocean loading and atmospheric pressure loading deformation not modeled.
-

Integration

- Cowell 11th order; step-size 100 sec.
-

Table 7.1.1.2-1. QLDAC computation model summary.

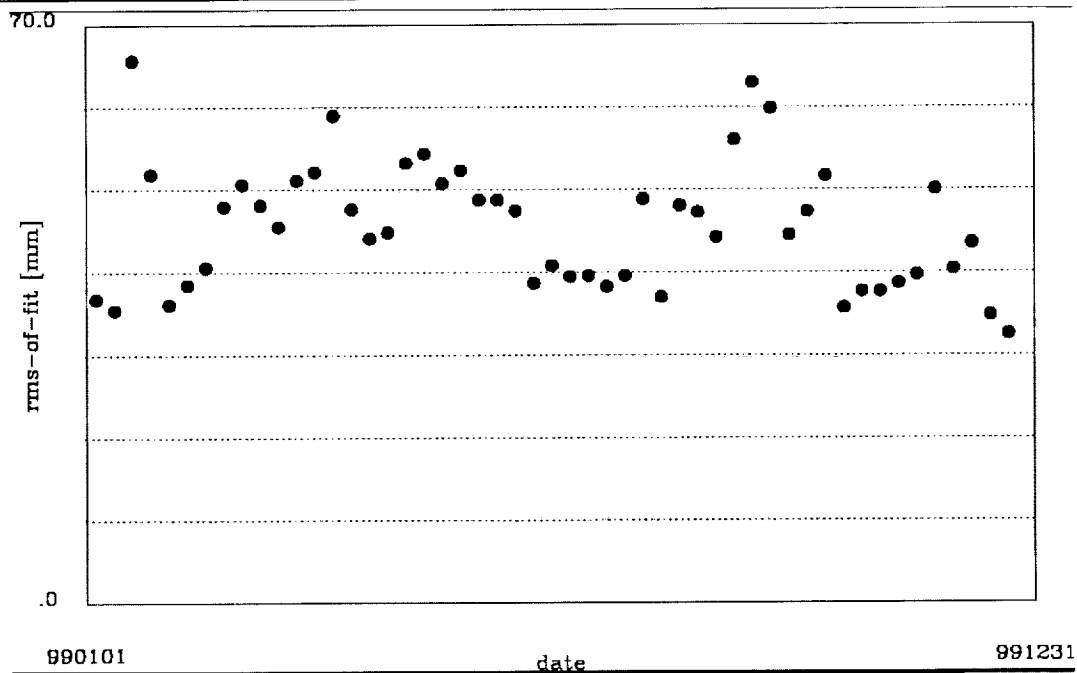

Figure 7.1.1.2-2. The weekly rms-of-fit obtained in the weekly quick-look analysis; note that this value is not minimized.

Station	#Obs	Mean	Rms	Weight
Riga, Latvia	132	45	53	104
Kazivili, Ukraine	21	-3	21	104
McDonald Observatory, Texas	33	2	19	36
Yarragadee, Australia	125	-17	37	31
Greenbelt, Maryland	343	-12	28	31
Monument Peak, California	317	-17	30	31
Changchun, China	265	-6	29	58
Beijing, China	79	-8	41	58
Koganei, Japan	122	1	26	36
Kashima, Japan	48	13	29	36
Miura, Japan	50	13	20	36
Tateyama, Japan	45	7	20	36
Arequipa, Peru	23	18	24	31
Cagliari, Italy	7	-1	92	76
Metsahovi, Finland	22	5	25	42
Zimmerwald, Switzerland	130	-10	34	67
Borowiec, Poland	23	-5	19	67
San Fernando, Spain	28	-0	27	50
Helwan, Egypt	1	4	4	31
Grasse, France	31	9	16	42
Potsdam, Germany	59	-11	21	42
Graz, Austria	84	19	29	31
Herstmonceux, United Kingdom	173	9	23	36
Grasse, France	18	-27	28	36
Mount Stromlo, Australia	207	-11	24	31
Matera, Italy	113	-6	97	123
Wetzell, Germany	67	-32	42	31

Table 7.1.1.2-2. Example of analysis results: the number of observations, mean and rms of the post-fit residuals and the individual data weights [mm], for the period October 21-30, 1999.

Another example, Figure 7.1.1.2-3 shows the time-history of the range bias for the Graz (station 7839), based on LAGEOS-1 measurements only (similar results, both in quantity and in numerical values, are available for LAGEOS-2, but inclusion of these results would lead to confusion in a plot like this). The consistency is, again, a good indicator of the quality of the analysis.

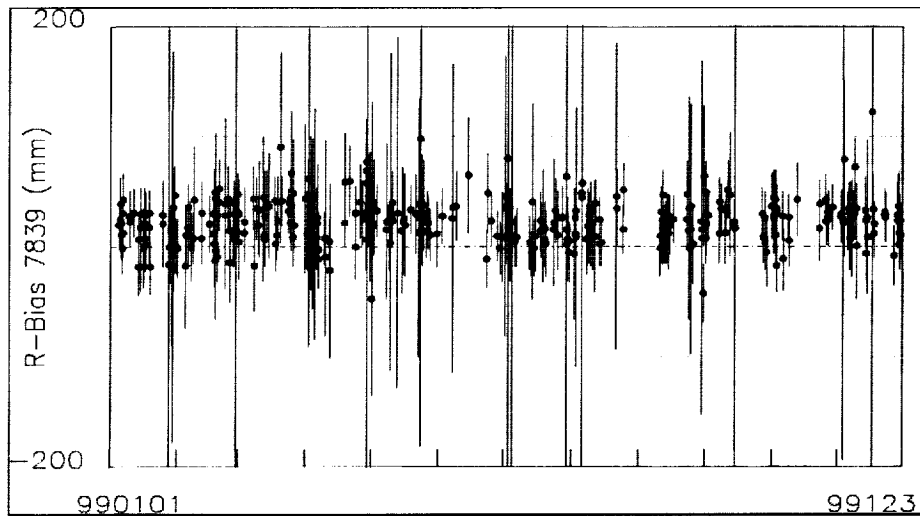

Figure 7.1.1.2-3. Time-history of the apparent range bias in the LAGEOS-1 passes as observed by the SLR station in Graz (Austria) for the year 1999, as determined by QLDAC.

OUTLOOK FOR 2000 AND BEYOND

In order to improve the quality of the QC analysis and the results, QLDAC intends to introduce several new elements in the operational analysis. First of all, the results will also be made available on the Internet. Users will have the opportunity not only to look at the latest analysis results, but also to look for time-series of certain performance parameters, both general and station-specific. Second, QLDAC intends to introduce a new model for station coordinates. The model which is currently in use was computed in 1993, and represents in fact an extrapolation of about 8 years by now. In order to achieve mm-level quality assessments, uncertainties in station coordinates of 1 cm or more are of course unacceptable. Directly related to this is the inclusion of models for ocean loading and atmospheric pressure loading deformation, and the modeling of station biases where necessary. Recently QLDAC has gained some experience with these issues. A long-standing wish is the inclusion of GPS satellites in the operational analysis. And, finally, QLDAC intends to increase the frequency of the analysis to 2 or 3 times per week, so that stations will receive more up to date reports on their performance. To accomplish this the analysis system needs to be automated.

The implementation of these improvements depends on the capabilities at QLDAC, in particular the manpower. Under any circumstances, QLDAC will strive for a continuous improvement to serve the SLR community as much as possible.

7.1.1.3 MCC Analysis Center

Vladimir Glotov, *Russian Mission Control Center*

INTRODUCTION/DATA PRODUCTS PROVIDED

Processing of the precise SLR and radio data started at the MCC in 1991. Previously most of the people were involved in the ballistic service supported by MCC. They supported the Mir orbital station and all related Russian manflight program missions. The MCC had many tasks, and up to 10 mission were served simultaneously in 1970's and 1980's. By the beginning of the 1990's there was considerable experience in data processing over a period of more than 20 years. Although the accuracy of the tracking radio data was much worse than that of SLR, it was extremely useful for new tracking systems calibration and verification, data analysis, data filtering, etc.

In 1993 the first version of the precise software (SW) was prepared at MCC for the processing of high-accuracy data, especially SLR. That SW was not of course absolutely perfect but the general idea was to provide simultaneous processing of an arbitrary number of satellites covering long time spans.

In 1993 the MCC started routine determination of Earth Orientation Parameters (EOP) first in the frame of the Russian National Program and then in cooperation with the IERS. Based on the LAGEOS satellites SLR data, EOP are sent weekly to the Central (Paris) and Rapid (Washington) IERS Bureaus. As reported in IERS Bulletins A and B, MCC EOP series are very comparable to those determined by other Centers using the satellite data. EOP accuracy has been improved to the level of a few millimeters. Plots are available at

<http://maia.usno.navy.mil/plots.html>

In 1996 the MCC and its subsidiary company GEOZUP (ZUP is the Russian abbreviation for MCC) performed the first annual solution based on LAGEOS SLR data since the end of 1992 in the framework of cooperation with the IERS. The adjusted set of the SLR station network coordinates from these analyses have allowed us to improve the accuracy of EOP by nearly a factor of 3. Obviously this improvement is related to the quality of orbits and SLR data analysis.

In 1996 MCC started a regular service of assessing SLR station performance. All the data of LAGEOS-1 and -2 have been analyzed to get values of time and range bias and the range RMS. In that analysis the mentioned values are determined with and without orbit height error. Comparison of the results allows us to get a more realistic evaluation of the SLR data. The routine service requires two levels of data filtering:

- automatically exclude outliers and wrong sessions
- manually check and correct results.

Special graphics SW was used to detect quality of observations in the manual mode. At the moment our official bulletin on station performance is issued once per week and sent to the CDDIS and EDC as well as directly to several SLR stations within WPLTN. Normally it includes estimations of almost all LAGEOS passes.

The routine orbits for the LAGEOS satellites are used for the estimation of data quality. The complete procedure was reported at the Deggendorf Workshop in 1998. In most cases the estimations are very close to those obtained by CSR. The major difference is seen for the new Keystone stations, probably due to the short time span of data available so far for position determination.

Since 1995, the MCC has permanently supported orbit determination of GLONASS satellites using SLR data. For this work a GLONASS solar pressure model was developed in 1996. All the data from GLONASS-63, 67 and 71 from 1995 through June 1997 have been processed to get high accuracy orbits. These orbits have been compared with the ephemerides obtained by the GLONASS System Control Center to get the transformation from the PZ90 reference frame to the ephemeris frame. Those results were obtained in 1997, long before IGEX and reported at ION98. In 1998-1999 MCC took an active part in IGEX98 (International GLONASS Experiment) as an Analysis Center for SLR data. Since October 1998 the MCC has provided routine precise orbit determination of all GLONASS satellites.

Orbits for the GLONASS satellites (in SP3 format) are regularly sent to the processing center for the determination of the final orbit using the phase data. As reported at the IGEX99 meeting, the MCC orbits are very compatible with those determined by BKG, CODE, JPL, and GFZ despite the differences in the amounts of laser and radio data. Accuracy has proved to be few decimeters. Due to the limited number of SLR measurements, MCC currently determines 8 days SLR GLONASS orbits with 4-days time shifts between solutions. The middle four days from each arc are then used for the generation of SP3 format.

The activity of the MCC is not limited to LAGEOS and GLONASS. MCC continually tries to improve the models and techniques of SLR data processing. In particular MCC has developed strong experience in the processing of relatively low orbits such as Meteor-3, ERS-1 and 2, Zeya, and Westpac. Despite the fact that these missions have not been sufficiently supported to provide a posteriori accurate orbits for several years, we have continued an activity in the improvements of the models. In particular several times it was our intention to start routine accurate orbit determination on WESTPAC for the preparation of bulletins like those issued for LAGEOS. However, corresponding orbits have been calculated but the amount of data were insufficient to allow us to determine accurate orbits. Due to the very short duration of the sessions, estimations of time and range biases varied much more than those on LAGEOS. So it was decided not to include WESTPAC data for PM and LOD nor for SLR data bulletins.

The data products available from MCC are:

- annual solutions
- regular daily values of PM and LOD
- bulletins of LAGEOS (GLONASS) SLR data performance
- GLONASS orbits in SP3 format
- transformation from PZ90 reference frame to WGS-84
- Westpac IRVS
- low satellites precise orbits
- etc.

BACKGROUND

In order to improve the quality of the generated products MCC performs two annual solutions each year. Both solutions are based on LAGEOS QL-NP data from the end of 1992 until the beginning of 2000. The first solution labeled as MCC(yy)L01 is performed by MCC specifically to adjust laser network and the EOP series from Bulletin B. The main idea is to improve the quality of PM and LOD reported to IERS. In 1999, positions of 58 stations and 40 stations velocities were adjusted simultaneously with satellite state vectors and some station biases in MCC99L01. These determined biases have been fixed in

the MCC99L02 solution where PM values have also been adjusted. Both solutions have the same following constraints to ITRF96 solution.

- Horizontal velocities for stations 1864, 1868, 1873, 1893, 7236, 7249, 7548, 7824 have been fixed to zero relative to the NUVEL-1A NNR model because either their biases change with time or data quality is insufficient.
- The velocities of 7105 and 7918, 1873 and 1893, 8834, 7597 and 7594, 7080 and 7850, 1884 and 1885, 7090 and 7847, 7835 and 7845, 7843 and 7849 were considered as equivalent. That does not mean that the velocities are identical but that the corrections made during the solution to the initial values from NUVEL1A-NNR model are identical. As a result the velocities of station 7843 differ slightly from the station 7849 due to several kilometers difference in their positions. A similar but smaller effect is visible for 1873 and 1893 pair.
- The motion of stations whose velocities were not estimated, due to the short time span covered, was constrained to the NUVEL1A-NNR model.

For the definition of orientation and time evolution in the MCC99L01 solution, EOP has been fixed to the EOP (IERS) C04 values. Additionally the longitude and its rate of station 7105 have been fixed to ITRF96 values. State vectors consisting of positions and velocities in J2000 and along track empirical acceleration for both LAGEOS satellites were adjusted on 6-days time intervals. In addition reflectivity coefficients were solved for on 24-day intervals, each covering 4 SV intervals. Time dependant biases for some stations were also included in the solution MCC99L01 where necessary.

Because of frequently changed biases, the data from 7847 and 1884 has been processed without applying Mathematical Expectation (ME). Such methods have been applied for stations: 1864 until 01/11/97, 1868 until 27/02/96, 1873 until 01/01/96, 8834 until 01/06/96 and 7249 for the summer of 1996. Those measurements have been considered as good but affected by unknown biases that change from pass to pass. This approach is extremely effective when there is a strong suspicion of changing bias (one of the reasons may be poor calibration).

Weighted RMS of residuals for the 1999-year solutions is about 2.5 cm. Unlike previous annual solutions (1996-1997 years) the number of raw measurements in each NP was not used in calculations. This method was used previously in 1998 and it has been proven by the MCC experience in polar motion determination since May 1998. The use of the number of raw measurements in the processing significantly improves the weighted RMS of the solution because the most stable and precise stations produce most of the measurements. However this approach actually excludes the influence of other stations in the orbit and EOP. In practice the models are not completely perfect and also relatively small and infrequent biases and drifts occur even in data from the best stations. So the use of extremely heavy weights for some non-optimally located stations can lead to the wrong results. To reduce this effect all NP were treated as single measurements with an RMS depending upon station and time. The adopted pass RMS values are in the range of 5 cm for the best US and European stations to 40-50 cm for some other stations.

It must be mentioned that every annual MCC solution is completely independent of previous results. This requires the estimation of a large number of parameters simultaneously, including: station coordinates, site velocities, time depending biases of some stations, satellite orbits and polar motion. In particular the MCC99L02 solution has 7221 adjusted parameters. One of the advantages of such an approach is the possibility to use state-of-the-art models for the processing of the whole data set. The quality of the solution is monitored by the comparison of independent 6-day arcs, which is very useful for the determination of the problematic periods.

Unlike the SSC determination, the routine MCC EOP determination is based on 3-days arcs. Data from both LAGEOS are processed simultaneously with PM and LOD values. Thus single determination solves for the following parameters:

- state vectors of both satellites in J2000
- empirical along track accelerations- solar pressure coefficients
- PM and LOD. Clearly the quality of 3-day orbits in most cases is better than of 6-day orbits.

That is why the EOP determined on 3-days arcs in the operational mode is even better than that obtained in the MCC(yy)102 solutions. In the routine service, initial values of PM and UT1-UTC corrections are either extracted from Bulletin A predictions or predicted by MCC SW. Celestial pole offset prediction is normally set to Bulletin A prediction. MCC does not produce UT1-UTC correction because it is not visible with SLR data. Any SLR based UT1 corrections are based on fixing the orbit node which must be updated over time.

In the regular EOP determination for IERS, special post-processing procedures are used for the improvement of accuracy. The procedure is repeated in the routine daily service. For any point there is 3 different solutions of EOP, which are averaged in the post-processing procedure. Usually that special averaging improves the accuracy by about 10-15%.

FACILITIES/SYSTEMS

Generally the facilities and systems of MCC Analysis and the Operation Centers are same (see section 5.2 of the Annual Report), but there are some additional details. The POLAR SW is used for the generation of all MCC products except IRVS. The POLAR SW has no database or graphics, but the number of parameters that can be determined is unlimited. It is completely flexible and different programs within POLAR can be used for different spacecraft. All of the coordinate solutions have been obtained using it.

The force and measurement models used in the solutions conform generally to the IERS Standards 1996 (TN21), with the following exceptions:

- the gravity field used is JGM3 with C20, C21 and S21 rates applied (the information was obtained directly from CSR),
- nutation corrections dPsi and dEps are applied,
- Earth infrared emission (with seasonal effects) and reflected light (with latitude dependent albedo) is taken into account,
- indirect C20 acceleration from the Moon is modeled.

The degree and order of the gravity field and tides clearly depends on the mission. Special methods of interpolation are used in the calculation of:

- nutation,
- sidereal time,
- solid and ocean tides,
- solid tides in station coordinates,
- UT1R,
- Daily and sub-daily variations of EOP,

These methods allow us to reduce computation time without losing accuracy. So, even though the SW is suited for the PC, it imposes no limitations on data processing.

CURRENT ACTIVITIES

At the moment, five products described above are available from MCC:

- annual solutions
- regular daily values of PM and LOD
- bulletins of LAGEOS SLR data performance
- Westpac IRVS
- GLONASS orbits in SP3 format

KEY POINTS OF CONTACT

Coordinator of the work	Vladimir Glotov	cnss@mcc.rsa.ru; vd.g@g23.relcom.ru
Main expert and person responsible	Vladimir Mitrikas	cnss@mcc.rsa.ru
Administration support	Sergey Revnivych	cnss@mcc.rsa.ru

FUTURE PLANS

In 1998 the development of new SW combining the features of STARK and POLAR has been started. So perhaps this year the operational MCC team will change to the new SW under Windows. The new SW is written combining DEC FORTRAN and C++ Builder. Most of the new features are directed toward automation of the operations. In the framework of the MCC SLR data analysis, there are traditional plans to improve the accuracy and quality of the products.

7.1.2 ASSOCIATE ANALYSIS CENTERS

Associate Analysis Centers are organizations that produce special products, such as satellite predictions, time bias information, precise orbits for special-purpose satellite, station coordinates and velocities within a certain geographic region, or scientific data products of a mission-specific nature. Associate Analysis Centers are encouraged to perform additional quality control functions through the direct comparison of individual Analysis Center products and/or the creation of "combined" solutions, perhaps in combination with data from other space geodetic techniques (e.g. VLBI, GPS, GLONASS, DORIS, PRARE, etc.), in support of the IERS International Terrestrial Reference Frame (ITRF) or precise orbit determination. Organizations with the desire of eventually becoming Analysis Centers may also be designated as Associate Analysis Centers by the Governing Board until they are ready for full scale operation.

7.1.2.1 FFI Associate Analysis Center

Per Helge Andersen, *Forsvarets Forskningsinstitut*

INTRODUCTION

Forsvarets forskningsinstitut (FFI, Norwegian Defense Research Establishment) is centrally located in the Kjeller area, 30 minutes east of Oslo (near Lillestrøm). Here approximately 2400 people are engaged in several research establishments, technical institutions, university branches and Air Force Material Command. FFI is a state operated, civilian research establishment reporting directly to the Ministry of Defense. The number of employees is approximately 550.

For many years FFI has performed research in space science and remote sensing using satellites. As a part of this research FFI has developed a highly sophisticated software called GEOSAT [Andersen, 1995] for satellite orbit determination and space geodesy. With this software all types of high precision space geodetic observations (VLBI, GPS, SLR, DORIS, PRARE, crossover radar altimetry, and externally generated satellite ephemerides) can be combined and analyzed at the observation level with one consistent observation model and common between-technique parameterization. Presently, scripts exist for an automatic processing of any combination of the VLBI, GPS, and SLR observation types.

FFI is presently an IVS Analysis Center, an IVS Technology Development Center, and an ILRS Associate Analysis Center.

COMBINATION OF VLBI, GPS, AND SLR DATA AT THE OBSERVATION LEVEL

There are several advantages with the combination of VLBI and different types of satellite tracking data at the observation level:

- One consistent model is used to construct the observation equations and observation partial derivatives for all the different types of data. The GEOSAT software will for the first time make it possible to perform analyses of VLBI and satellite tracking data with one consistent model and strategy.
- The combination of independent and complementary information from different types of observations will reduce the parameter correlations and lead to more accurate results.
- The estimated satellite orbital elements, radio source coordinates, and nutation parameters will be realized in a long-term stable celestial reference frame realized primarily by the radio sources. GPS and SLR will contribute directly in the determination of UT1 and not only be used to estimate the length of day (LOD).
- All estimates of geodetic and geodynamic parameters are given in the same realization of the terrestrial reference frame.
- The combined analysis of VLBI, GPS, and SLR can be used to estimate (and control) the eccentricity vectors between the different antenna phase centers within each collocated station.

The main problems with the combination of different types of data at the observation level compared to an individual analysis of each data type are that the analysis software becomes extremely more complicated and the computation time increases with one to two orders of magnitude.

All planned components of GEOSAT have been successfully validated with a combination of data from VLBI, GPS, and SLR. Consistent models for all techniques have been verified at the sub-ppb level. The processing at the arc level (24 hours arc length) is completely automated.

PRESENT AND FUTURE PRODUCTS

FFI is currently producing a 10-year solution for the Celestial reference frame, the Terrestrial reference frame (including geocentric motion) and Earth orientation parameters based on a combination of VLBI and SLR data. A corresponding VLBI-only solution will also be generated. In addition, a SLR-only solution for LAGEOS I and II with data from January 1993 to the end of 1999 will be computed. The 10-years combined VLBI and SLR solution will be extended with arcs including also GPS data for selected periods. In the future it is planned to investigate the estimation of other types of parameters for example loading parameters (atmospheric/ocean), GM and possibly relativity parameters (β and γ).

TECHNICAL STAFF AND FACILITIES

The author runs a one-man internal FFI project that is approved until August 2002. The project covers all space geodesy activities within FFI and one of the main goals is to generate products for IERS, IVS, and ILRS.

A new HP J7000 workstation with 4 CPU's and 4 Gb RAM and presently 165 Gb disk space is dedicated to the IERS, IVS and ILRS activities at FFI. Within year 2000 we expect to extend the disk space to 365 Gb. Last year a HP C 180 workstation with 1 CPU and 256 Mb RAM and 65 Gb disk space was used in the analyses. The new workstation is expected to improve the computation power with one order of magnitude.

REFERENCES

Andersen, P. H. (1995) High-precision station positioning and satellite orbit determination. Ph.D. Thesis, NDRE/Publication 95/01094.

7.1.2.2 DGFI Associate Analysis Center

Detlef Angermann, *Deutsches Geodatisches Forschungs Institut*

INTRODUCTION

For almost twenty years, the German Geodetic Research Institute (DGFI) has been strongly involved in the high precision processing of SLR data for many geodetic and geophysical investigations. These include the determination of the Earth's surface geometry and its variation with time, as well as the determination of the Earth's orientation in space and the determination of the Earth's gravity field and its variations with time [Reigber, *et al*, 1993].

DGFI is acting as an Associate Analysis Center within the ILRS and participated in the ILRS99 pilot project on the determination of station positions and Earth orientation parameters based on LAGEOS-1 data. The focus of the present activities is on the automation of the SLR data analysis in order to estab-

lish an operational analysis center for the determination of ILRS products and on the computation of a global SLR solution for the ITRF2000.

SOFTWARE AND PROCESSING TECHNIQUE

DGFI developed the software package DOGS (DGFI Orbit and Geodetic Parameter Estimation System), which has been used for the computation of SLR data since 1980. The DOGS software system comprises the following main modules:

DOGS-IN: Input Generation for the computation of global SLR solutions, including program regulation, composition of station data, observations, and geometrical and physical models.

DOGS-OC: Satellite orbit and parameter adjustment module for orbit improvement, satellite specific and geodetic parameter estimation or normal equations generation for these parameters.

DOGS-CS: Parameter estimation module to combine normal equation systems for different satellite arcs, different data types, to eliminate nuisance parameters, to generate normal equation systems with and without constraints and to perform the inversion of the combined normal equation systems.

DOGS-OV: A set of programs incorporated for quality control, calibration and graphical representation of the solutions.

The DOGS parameter solutions are based on efficient techniques for the orbital integrator, the integration of the variation equations and the weighted least squares adjustment procedures. The reference frame, conservative and non-conservative force field parameters and measurement model parameters are defined close to the IERS Conventions 1996 [McCarthy, 1996].

According to the processing strategy used, DOGS allows the adjustment of the following parameters: 6 orbital elements, solar radiation scaling factors, along track acceleration values, Earth orientation parameters, gravity field parameters, geocenter variations, station coordinates and velocities, range and time bias values. For the definition of the geodetic datum, minimum constraints are used. Since the origin of the reference system is the geocenter, by setting the first degree and order terms of the gravity model to zero and the scale being defined by the velocity of light, the orientation remains to be defined because of the insensitivity of the range observations to rotation. In general we define the geodetic datum with respect to the latest ITRF realization by minimizing the common rotation with respect to the initial coordinates of a well-defined set of globally distributed stations [Gerstl, 1999].

ILRS PILOT PROJECT 1999: DGFI RESULTS FOR POSITIONS AND EOP

Within the ILRS pilot projects “positioning” and “Earth orientations” the DGFI computed a coordinates solution for the global network of SLR stations and a time-series of Earth orientation parameters at 3-day intervals in one simultaneous solution with the DGFI software DOGS. We computed the 28 days of LAGEOS-1 data (5.9.-2.10.1999) on the basis of 7-day arc solutions and combined these weekly solutions into one unique solution [Angermann *et al.*, 2000]. The solved-for parameters are: 6 orbital elements, solar radiation scaling factors and acceleration along track values every 5 days, Earth orientation parameters at a 3-day interval and station coordinates. We used minimal constraints for the definition of the geodetic datum. We introduced *a priori* constraints of 0.0001 m for the y- and z-coordinate of station 7840 and the z-coordinate of station 7105, as well as an *a priori* constraint of 0.1 ms for the UT1-correction at one epoch. These constraints can easily be removed from the variance-covariance matrix for comparisons and combinations. The solution products were distributed in SINEX format. The quality

of the adjusted station coordinates was assessed by a comparison with those of the ITRF97. The mean differences between both sets of station coordinates are in the order of 2 cm for 19 globally distributed SLR stations. The estimated pole coordinates and UT1 corrections agree with the corresponding IERS (EOP97C04) values at the 0.5 mas, 0.2 ms level, respectively.

FUTURE ACTIVITIES:

The DGFI will continue with its participation in future ILRS pilot projects and will establish an operational analysis center for the computation of SLR solutions based on LAGEOS-1 and -2 data and the estimation of geodetic and geophysical parameters, such as station coordinates and velocities, Earth orientation parameters, geocenter variations. The DGFI will produce a global SLR solution, which will be submitted to the IERS as a contribution to the ITRF2000.

REFERENCES:

- Angermann, D., M. Gerstl, R. Kelm, H. Müller, W. Seemüller: ILRS 99 Pilot Project: DGFI Solution for Station Coordinates and EOP's, ILRS Analysis Working Group workshop, 17.-19.01.2000, Frankfurt a.M., 2000.
- Gerstl, M.: Bezugssysteme der Satellitengeodäsie, Mitteilungen des Bundesamtes für Geodäsie und Kartographie, Band 5, Frankfurt a.M., 1999.
- McCarthy, D.D. (ed.): IERS Conventions (1996), IERS Technical Note 21, Central Bureau of IERS, Paris, 1996.
- Reigber, C., P. Schwintzer, F.-H. Massmann, C. Förste, H. Drewes: Ten Years of SLR Data Analysis at DGFI/I, Contributions of Space Geodesy to Geodynamics: Crustal Dynamics, D. E. Smith, D. Turcotte (eds.), Geodynamics Series, Vol. 23, American Geophysical Union, Washington, D.C., 1993.

7.1.2.3 NERC Associate Analysis Center

Graham Appleby, *NERC Space Geodesy Facility*

INTRODUCTION

In this report we outline some of the analysis and operational activities of the NERC SLR Facility at Herstmonceux and Monks Wood, UK, in the Facility's capacity as an ILRS Associate Analysis Center. Much of the prediction preparation and quality control work that is described here has been developed in order better to equip the Herstmonceux SLR system to maximize its productivity during periods of clear weather. For single-photon detector systems in particular, prediction accuracy is important as it allows the use of narrow range gates (<200 ns) to minimize background noise. That these products are used by many colleagues within the ILRS network is a valuable spin-off from the work.

SATELLITE PREDICTIONS

We compute two main prediction products, medium-term and daily, and are actively experimenting to improve their quality. The predictions are presented in the standard Inter-range Vector (IRV) format.

Access information and the full list of satellites for which we produce predictions is given on the official ILRS website. We compute predictions on a daily basis for most of the laser-tracked satellites and for the GLONASS satellites, we support the IGEX-98 tracking campaign by computing daily IRVS in collaboration with the CODE, Berne, group. We are currently generating predictions on an experimental basis for some LEO satellites twice per day using the most recent observations to check whether significant improvements to predictive quality can result. This latter work is being carried out as part of our involvement with the ILRS Data Formats and Procedures Working Group.

TIME BIAS FUNCTIONS

The computation of along-track corrections can significantly improve the quality of medium and long-term predictions. We routinely compute time bias functions applicable to most of the available prediction sets, and update the coefficients hourly using the latest observations from the network. Access to these functions is hourly via local ftp or by daily e-mail via EDC. We plan in the near future to present the same information in graphical form on the NERC SLR website.

DAILY QUALITY MONITOR

As an initiative within the EUROLAS network some years ago we began regularly to monitor the quality of LAGEOS and LAGEOS-II range data from the network, using ITRF97 station coordinates. In particular we exploited the strength of the EUROLAS cluster of stations to form short-arc orbital improvements and thus potentially detect system bias at the 10mm level. This procedure was automated and implemented on a daily basis in a valuable collaboration with the Department of Satellite Geodesy, Austrian Academy of Sciences, Graz, [Hausleitner, *et al*, 1999]. Each day we present on the NERC SLR website plots of normal-point range residuals from six-day orbital solutions for the two satellites for each station in the global network. Following some modelling improvements during this year, the post-solution residual RMS for these orbital solutions has improved to about 20mm, and the plots serve to provide a rapid check on the presence of outliers in the tracking data, as well as a quick daily check on network productivity. An example of the results from four stations is shown in Figure 7.1.2.3-1, where on the Website the LAGEOS-1 residuals are colored red and the LAGEOS-2 residuals are colored blue.

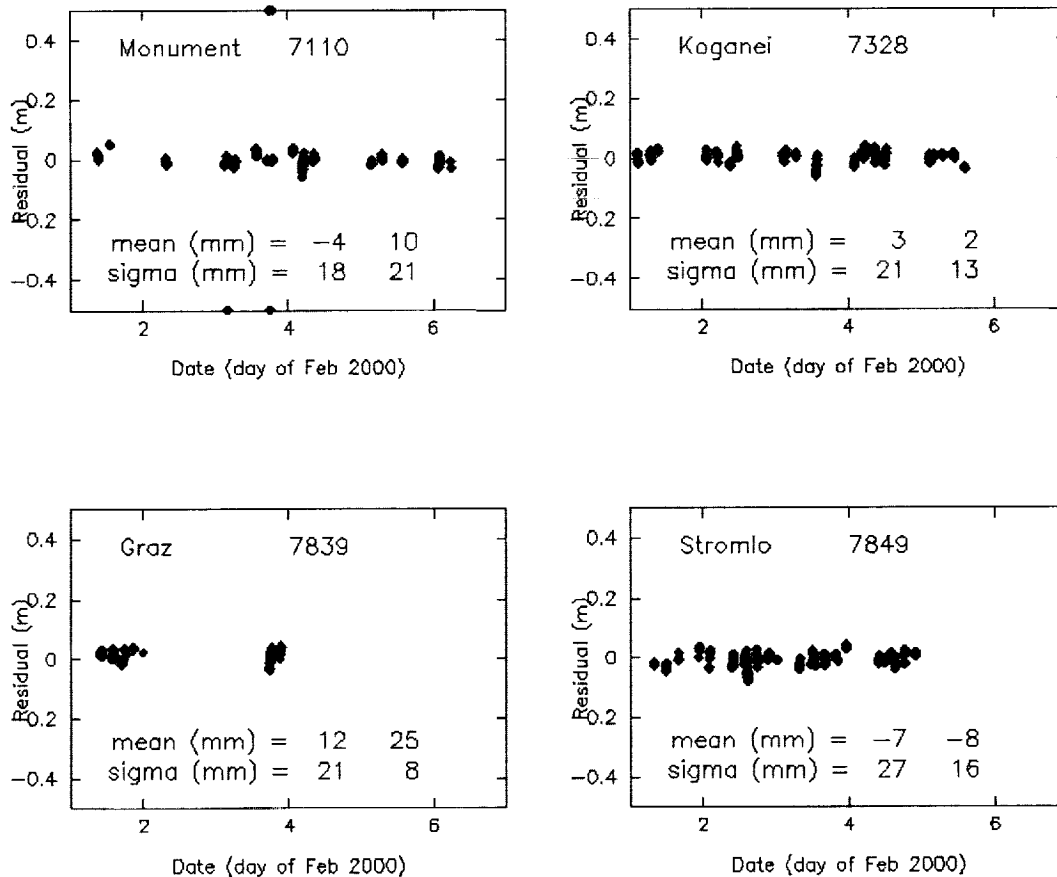

Figure 7.1.2.3-1. Plots of range residuals from fitted 6-day orbits of LAGEOS-1 and -2.

We then determine which, if any, passes during the six days have been tracked simultaneously by more than two EUROLAS stations, and carry out a short-arc orbital correction. The residuals from this improved orbit give a good indication of the relative tracking quality of the stations, at a level of 10mm or so, and again are presented daily in graphical form on the website.

We plan to take part in a study to compare these results with other groups' determinations of tracking quality, which is being coordinated by the ILRS Analysis Working Group.

GLONASS ORBITAL DETERMINATION

We are carrying out a study to use SLR observations of the GLONASS satellites during the continuing IGEX98 tracking campaign to check the quality of the available microwave-based orbital solutions. The SLR observations are used in two ways. Firstly we generate 7-day orbits and compare them to the microwave orbits, achieving RMS differences in the radial direction of about 20 cm. We are also comparing the laser range measurements directly to the positions of the satellites given by the microwave orbits, in order particularly to investigate possible laser-array-induced systematic differences. A paper by Appleby, Otsubo and Sinclair on this work was presented at the IGEX Workshop in Nashville during 1999 September, and has been submitted for publication in the proceedings.

ILRS ANALYSIS WORKING GROUP (AWG) PILOT STUDY

We are taking part in an AWG pilot study to determine the procedures required to compute a regular ILRS product. We have computed a monthly solution for station co-ordinates and EOPs using LAGEOS data and submitted it at the end of the year for comparison with results from other analysis groups.

REFERENCES

Appleby, G.M., Gibes, P., Sherwood, R.A., Wood, R. Achieving and maintaining sub-centimeter accuracy for the Herstmonceux single-photon SLR Facility, in SPIE Proc., U. Schrieber and C. Werner, eds., vol 3865, pp 52-63, (Florence) 1999.

Hausleitner, W., Appleby, G.M., Sinclair, A.T. Rapid quality checks within the EUROLAS Cluster. Proc 11th Int. Laser Ranging Workshop, pp 621-626, BKG, Frankfurt, 1999.

ACKNOWLEDGEMENTS.

The NERC SLR Facility at Herstmonceux and at Monks Wood, UK, is funded by the Natural Environment Research Council in collaboration with the British National Space Center and the Ministry of Defense.

It is a pleasure to acknowledge the contribution to many aspects of the work of the Facility by visiting scientist Mr. Toshimichi Otsubo, on leave from the Communications Research Laboratory, Tokyo, Japan, and to thank CRL for their continuing support.

7.1.2.4 ASI/CGS Associate Analysis Center

Vincenza Luceri, *Telespazio, SpA*

INTRODUCTION

The Space Geodesy Center, Centro di Geodesia Spaziale (CGS) "G. Colombo" (CGS) of the Italian Space Agency (ASI), is located near Matera, southern Italy.

The CGS began its activity on 1983 as a result of an agreement between ASI and NASA; when a SLR system, SAO-1, was installed at the CGS; it is still operational to date. In 1990 a Very Long Baseline Interferometry (VLBI) 20m radiotelescope was installed, in 1991 the Global Positioning System (GPS) activities started with the installation of a permanent GPS Rogue receiver and, at the beginning of 1996, also the operations of the Precision Range and Range-rate Experiment (PRARE) started.

The near future will be highlighted by the Matera Laser Ranging Observatory (MLRO), a state-of-the-art Satellite and Lunar Laser Ranging facility whose excellent data quality has already been demonstrated by the first results achieved during the collocation experiment at the Goddard Geophysical and Astronomical Observatory. The system is now being installed in Matera.

However, the CGS is not only an observing site; data from SLR, VLBI and GPS techniques are routinely analyzed by the CGS analysis group to investigate several geophysical processes.

Besides the space geodesy activities, the CGS is involved in various projects on remote sensing, space robotics and interplanetary missions.

All the operational activities, the engineering support and the geodetic data analysis have been committed to Telespazio SpA.

FACILITIES

The CGS computer configuration comprises some HP workstation and PCs on a LAN network. The SLR analysis is performed using the GSFC/NASA Geodyn-II/Solve software for orbit determination and geodetic parameter estimation. Several other locally developed programs are used for parameters postprocessing.

DATA ANALYSIS

The SLR data analysis has a relatively long history at the CGS. Started in 1984 with the on-site quality control, it is now a well established activity focused on the areas of tectonic plate motion, crustal deformation, post-glacial rebound and subsidence, Earth rotation and polar motion, time variations of the Earth's gravitational field, center of mass of the total Earth system monitoring, International Terrestrial Reference System (ITRS) maintenance, and satellite orbit determination.

The analysis products can be classified into three main types: *standard*, *special* and *multi-technique*.

The *standard* are the basic products of the SLR analysis and contribute to the monitoring of the terrestrial reference system through a set of coordinates and velocities of the worldwide network and the Earth orientation parameters. Those products are routinely distributed to the International Earth Rotation Services (IERS) and are listed below:

- estimated coordinates and velocity field (SSC/SSV) of the SLR network and the Earth Orientation Parameter (EOP) are provided yearly to the IERS in order to realize the Terrestrial References Frame;
- monthly estimated EOP are provided to the IERS as a contribution to the realization of the Bulletin B distributed to the scientific community.

The *special* and the *multi-technique* are those products requiring specific investigation and not routinely produced. They can be grouped into the following areas:

- precise orbit determination (POD):
 - orbit estimation for several geodetic satellites: LAGEOS I, LAGEOS II, Starlette, Stella and ERS1;
 - interpretation of the non-gravitational accelerations acting on LAGEOS satellites;
 - investigation on the LAGEOS rotation using MLRO data;
- gravitational field:
 - time series of estimated low degree geopotential coefficients from the analysis of different geodetic satellites and determination of their secular drift as a contribution to the definition of the Earth mantle viscosity profile;
- geocenter:

- time series of the geocenter motion within the “IERS analysis campaign to investigate motions of the geocenter”;
- inter-technique combination/comparison:
 - comparison of Terrestrial Reference Frames and velocity field estimated with SLR, GPS and VLBI data;
 - comparison of EOP from SLR and VLBI;
 - combination (at normal equation level) of SLR and GPS data;
 - estimation of tectonic movements in the Mediterranean area combining SLR, GPS and VLBI results.

The CGS is participating to the ILRS pilot projects, defined by the analysis working group, submitting its solutions and performing comparison/combination among solutions.

Other information on the CGS and some of the analysis results are available at the CGS WWW server Geodetical Data Archive Facility (GeoDAF) at:

<http://geodaf.mt.asi.it>

MOST RECENT PUBLICATIONS

Bianco, R. Devoti, M. Fermi, C. Ferraro, R. Lanotte, V. Luceri, A. Nardi, R. Pacione, P. Rutigliano, C. Sciarretta, F. Vespe, Comparison of Space Geodetic Data Analysis Results at the CGS, in Bjorn R. Petersen (ed.), Proceedings of the 12th Working Meeting on European VLBI for Geodesy and Astronomy, Honefoss, Norway, 12-13 September 1997, ISBN 82-90408-41-2, 74, 1997

G. Bianco, R. Devoti, M. Fermi, V. Luceri, P. Rutigliano, C. Sciarretta, A contribution in the estimation of tectonic motion in crucial areas: the CGS96 SLR solution, Tectonophysics 294, 225-236, 1998

G. Bianco, R. Devoti, M. Fermi, V. Luceri, P. Rutigliano, C. Sciarretta, Estimation of Low Degree Geopotential Coefficients using SLR Data, Planet. Space Sci., 46 (11/12), 1633-1638, 1998

L.L.A. Vermeersen, R. Sabadini, R. Devoti, V. Luceri, P. Rutigliano, C. Sciarretta, G. Bianco, Mantle viscosity inferences from joint inversion of Pleistocene deglaciation-induced changes in geopotential with a new SLR analysis and polar wander, Geophysical Research Letters, 25 (23), 4261-4264, 1998

KEY POINTS OF CONTACT

Dr. Giuseppe Bianco
ASI - CGS, P.O. Box ADP, 75100
Matera - Italy
tel: +39-0835-377209
fax: +39-0835-339005
e-mail: giuseppe.bianco@asi.it

Dr. Vincenza Luceri
Telespazio SpA - ASI CGS, P.O. Box
ADP, 75100 Matera - Italy
tel: +39-0835-377231
fax: +39-0835-334951
e-mail: cinzia.luceri@asi.it

7.1.2.5 GFZ Associate Analysis Center

Franz-Heinrich Massman, *GeoForschungs Zentrum Potsdam*

INTRODUCTION/DATA PRODUCTS PROVIDED

Besides its involvement in the SLR data acquisition through operation of the Potsdam station, The GeoForschungsZentrum Potsdam (GFZ) is actively contributing to the ILRS as an Associate Analysis Center with the following products:

- Routine generation and distribution of IRVs (actual satellite missions ERS-1, ERS-2 and GFZ-1, past missions: METEOR-3/7, D1-C, D1-D and MIR)
- Continuous time bias monitoring of the predictions (ERS-1, ERS-2, GFZ-1)
- Provision of Two-Line Elements (ERS-1, ERS-2, GFZ-1)
- Computation of improved Earth gravity field model (GRIM5, jointly with GRGS/CNES)
- Estimation of station positions and velocities (GRIM5, jointly with GRGS/CNES)

BACKGROUND

For almost ten years GFZ has been responsible for the operational, off-line, precision orbit determination of the ERS satellites in the framework of the German Processing and Archiving Facility (D-PAF) of the ERS ground segment of the European Space Agency (ESA). This includes the coordination and support of the ERS SLR tracking by SLR predictions, time bias monitoring, reports and maneuver information. The systematically generated precision ERS orbits (rapid, preliminary, precise) are ESA standard products and are available via the ERS order desk at ESRIN (Frascati/Italy).

With the launch of GFZ-1 in April 1995 the activities were extended to GFZ's own satellite mission. Due to its orbital characteristics (lowest geodetic satellite, altitude decreasing from 390 km) it was a great challenge for all participants. Up to its predicted decay in June 1999 a large number of SLR returns were acquired and used for precise orbit determination as well as for Earth gravity modelling.

In continuation of a fruitful cooperation with GRGS/CNES, a new iteration of the GRIM Earth gravity field models has been initiated. This includes the reprocessing of about 15 satellites equipped with SLR, PRARE, DORIS and GPS on the basis of the GRIM5 standards. In 1999 the first resulting solutions were presented: GRIM5-S1 (satellite-only) and GRIM5-C1 (combined). Independent comparisons demonstrated the high quality of this solution. The available normal equations formed also the basis for an estimation of station coordinates and velocities.

FACILITIES/SYSTEMS

Section 1.2 (Satellite Mission Development and Operations, Oberpfaffenhofen near Munich) of GFZ and Section 1.3 (Gravity Field and Figure of the Earth, Potsdam) are responsible for the above mentioned activities. The computations are performed on a cluster of SUN workstations, which are also used within other projects. They include desktop stations up to Enterprise servers (3000, 3500) with multiple CPUs (6-8). For the gravity activities the massive parallel processor in Potsdam has also been involved (HP S2000, HP V2500, 16 CPUs each). The operating system was Solaris 2.5/2.6 and has recently been

changed uniformly to Solaris 7, while the HPs are running with HP UX. All processing software (EPOS: Earth Parameter and Orbit System) was developed by team members and is the result of more than 10 years of operation experience. The software is written in Fortran 77 or Fortran 90, and a few modules are in C.

CURRENT ACTIVITIES

The operational activities for the ERS-1 and ERS-2 satellites are ongoing as both satellites are in good condition (as of the time of this writing) and SLR is needed for the precision orbit determination. The high solar activity and the maintenance of the Tandem configuration does require frequent maneuvers.

In view of the upcoming CHAMP satellite mission a corresponding orbit prediction system has been set up. SLR tracking at highest priority is requested during the first two weeks after launch scheduled for the end of April 2000. For the rest of the five year mission, SLR tracking priority can be relaxed as SLR then complements the onboard GPS tracking system. Mission goals are gravity recovery from GPS and SLR data and two color experiments. Acquisition data will be provided by GFZ.

In order to achieve further improvements in gravity field modelling additional SLR data from Geosat Follow-on, Sunsat, etc. will be processed and included in new solutions.

KEY POINTS OF CONTACT

Franz-Heinrich Massmann
GFZ Potsdam, Division 1
Section 1.2: Satellite Mission Development and
Operations
c/o DLR Oberpfaffenhofen
82234 Wessling
Germany
Phone: (+49) 8153 28 1206
Fax: (+49) 8153 28 1585
E-mail: fhm@gfz-potsdam.de

Dr. Rolf Koenig
GFZ Potsdam, Division 1
Section 1.2: Satellite Mission Development and
Operations
c/o DLR Oberpfaffenhofen
82234 Wessling
Germany
Phone: (+49) 8153 28 1353
Fax: (+49) 8153 28 1585
E-mail: rolf.koenig@gfz-potsdam.de

FUTURE PLANS

Future activities are concentrating on the CHAMP satellite mission. The acquired SLR, GPS and accelerometer data will be used to compute precision orbits and to derive improved (one order of magnitude) Earth gravity models every few months in order to monitor temporal variations.

The orbit predictions system will be migrated to the generation of acquisition data for the GRACE satellite scheduled for launch in 2001.

7.1.2.6 AUSLIG Associate Analysis Center

Ramesh Govind, *Australian Surveying and Land Information Group*

BACKGROUND/INTRODUCTION

The AUSLIG Associate Analysis Center has been routinely processing LAGEOS-1 and -2 data for satellite for orbit determination, station coordinates, Earth Orientation Parameters and SLR station performance monitoring. In addition, on an opportunity or project basis, Stella, Starlette, Etalon and GLONASS data is also processed. This work to-date has been reported in the attached list of publications. There is an ongoing emphasis on the co-location and combination of SLR with other space geodetic techniques. Recent activities have been the three epochs of observations and processing [1997, 1998 and 1999] for the Asia - Pacific Regional Geodetic Project (APRGP) of the Permanent Committee for GIS Infrastructure for Asia and the Pacific (PCGIAP). Twelve months of combined LAGEOS-1 and -2 solutions have been submitted to the IERS Time Series Pilot Project. Also, six months of GLONASS was processed as part of the IGEX-98 campaign.

FACILITIES/SYSTEMS

The current computation facilities in the AUSLIG Space Geodesy Analysis Center is comprised of four HP workstations [C160, C180, C360 and L2000]. The processing system uses the MicroCosm suite of programs for orbit determination and geodetic parameter estimation as the engine. NASA's SOLVE program is used for the combination solutions. A suite of programs have been developed in-house for analysis and re-formatting. Final results are provided in the SINEX format.

CURRENT ACTIVITIES

The current activities are:

- Participating and contributing to the three ILRS Analysis Working Group pilot projects [station coordinates and EOPs, Orbit comparison and the software/standards comparison].
- Continue submitting results to the IERS Time Series Pilot Project.
- At this stage there is a concerted effort to contribute a significant SLR solution (LAGEOS) to the ITRF2000.

FUTURE PLANS

- Continue submitting results to the IERS.
- Provide global solutions as a full analysis center to the ILRS when the AWG coordination structures are established.
- Extend routine processing and analysis to Stella, Starlette, Etalon, GLONASS and LEOs.
- Provide a station monitoring service.

RELATED PUBLICATIONS

Govind, R., J. Dawson, G. Luton and D. Sproule (1998): "Satellite Laser Ranging Solutions", Proceedings, Workshop on Regional Geodetic Network, Working Group 1, Permanent Committee on GIS Infrastructure for Asia and the Pacific, Canberra, Australia, 2nd - 4th July, 1998.

Dawson, J., R. Govind, G. Luton, and D. Sproule: (1998) "Asia Pacific Regional Geodetic Project 1997", presented Western Pacific Geophysics Meeting, Taipei, Taiwan, 21-24 July, 1998.

Govind, R., J. Dawson, G. Luton and D. Sproule: (1998) "Combination of High Precision Space Geodetic Techniques: The Asia and Pacific Regional Geodetic Project 1997", Advances in Space Research, Vol.23, #4, pp 797-807, 1990, and presented 32nd COSPAR Scientific Assembly, Nagoya, Japan, July, 1998.

Govind, R., J. Dawson, G. Luton, and D. Sproule: (1999) "Combination of High Precision Space Geodetic Techniques", Proceedings of the International Workshop on Geodetic Measurements by Collocation of Space Geodetic Techniques on Earth (GEMSTONE), Communications Research Laboratory, Tokyo, Japan, 25-28 January, 1999.

Govind, R., J. Dawson, and G. Luton: (1999): "Asia Pacific Regional Geodetic Project 1998 - GPS, DORIS and SLR Results and Analysis", Proceedings, Workshop on Regional Geodetic Network, Working Group 1, Permanent Committee on GIS Infrastructure for Asia and the Pacific, Ho Chi Min City, Vietnam, 12th - 13th July, 1999.

Govind, R., J. Dawson, and G. Luton: (1999) "SLR GLONASS Orbit Determination", presented (in proceedings), IGEX-98 Workshop, Nashville, Tennessee, 13th-14th September, 1999.

Govind, R., J. Dawson, and G. Luton: (1999) "A comparison of SLR and Microwave Determined GLONASS Orbits", to be presented, The International Symposium on GPS - Application for Earth Sciences and Interaction with other Space Geodetic Techniques, Tsukuba, Japan, 18-22 October 1999.

KEY POINT OF CONTACT

Dr. Ramesh Govind
AUSLIG/Geodesy
PO Box 2, Belconnen, ACT 2616,
Australia.
Phone: 61 2 62014 371
Fax: 61 2 62014 366
E-mail: rameshgovind@auslig.gov.au

7.1.2.7 OCA/CERGA Associate Analysis Center

Pierre Exertier, *Centre de Recherche en Géodynamique et Astrométrie*

INTRODUCTION

Laser tracking tracking from regional networks of stations is an important means of controlling range biases. The International Laser Ranging Service (ILRS) has been organized and this report presents the

participation of the OCA/CERGA Associate Analysis Center at the Grasse, France Observatory in this field.

For more than 20 years, the French geodynamic site located near Grasse, France has participated in the tracking of many geodynamic, geodetic, and oceanographic satellites. At Grasse there are three independent laser ranging instruments: a classical Satellite Laser Ranging (SLR) station, a Lunar Laser Ranging (LLR) station, and the French Transportable Laser Ranging Station (FTLRS).

The opportunity to have three independent laser stations located on the same site is unique for detecting errors and biases specific to each station. It also fulfils the purpose of the ILRS (International Laser Ranging Service), to control measurement accuracy and bias stability, and to improve efficiency.

For several years, in order to decrease the laser system biases, the hardware and the scientific and technical data analysis have been constantly upgraded. See the reports of Francis Pierron on SLR and the FTLRS stations and the report of F. Mignard concerning the tracking of high satellites (and the Moon) by the LLR station.

DATA PRODUCTS PROVIDED

LAGEOS and other satellites

For this purpose, since 1997, a collocation experiment has been carried out between the LLR and the SLR fixed stations on the LAGEOS 1 and 2 satellites. This kind of cross-analysis provides some evidence of the objective quality of the stations and their positioning, providing a possible detection of instrumental bias and seasonal signals with their geophysical interpretation.

We use the LAGEOS satellites (altitude of 6000 km) because they are the lowest targets accessible to the LLR station and the highest to the FTLRS. Moreover, they are routine targets for the SLR fixed station, which ranges to satellites at altitudes between 350 and 20000 km (from GFZ to the GPS and GLONASS constellations).

The dynamic orbit determinations on LAGEOS can also be used to estimate the data quality of the SLR and LLR stations. The mean value of the residuals can be computed for the whole international laser network or for individual stations such as the Grasse SLR and LLR. However at this stage, it is important to keep in mind that the LLR data have not been included in the orbit determination. The standard deviations of these residuals can also be computed in the same conditions. The arcs from 1998 have been evaluated and the following quantities have been computed:

- The mean value of the residuals for all of the 10-days arcs for the SLR and the LLR stations. They are (0. +/- 0.6) cm and (1.5 +/- 1.24) cm, respectively. The nominal value of the LLR bias is due, at this stage, to the non-adjustment of the LLR coordinates and to the fact that the LLR data are not included in the orbit computation.
- The mean value of the standard deviation for all of the 10-days arcs for the SLR and the LLR stations. They are (2.0 +/- 0.3) cm and (2.0 +/- 0.6) cm, respectively. For all the stations used in the orbit computation we get (2.2 +/- 0.6) cm.

These values show great stability of the data quality at the level of a few millimeters for all the stations considered, and specifically for the Grasse SLR and LLR ones. The 2.2 cm mean laser residual rms comes from: instrumental biases at each station, station coordinate errors, LAGEOS signature, tropospheric delay, and gravity field determination errors and non-gravitational modeling errors.

The station positions, and in particular the altitude, have been determined in each of the four seasons in 1998, as well as for an annual mean bias. In 1998, for the Grasse SLR and LLR stations, the mean annual biases were of ($\pm 4.5 \pm 0.7$) mm and (0.6 ± 1.1) mm, respectively. These values demonstrate a very good stability at a few millimeters level along the year, what is satisfactory in terms of a SLR standard station.

Considerable progress has been realized since 1997 at the Grasse SLR fixed station, with a new photodiode system. The bias is much smaller than in the years before 1997 (0.5 cm instead of 3-4 cm) and there is now a very good stability (± 0.7 mm). As a result the photodetector in the FTLRS is also being upgraded.

GLONASS and GPS-35, -36 satellites

With the quality of the existing networks, and in part due to the action of the ILRS, it is possible to control the orbit quality for satellites like GPS, GLONASS (IGEX experiment). This is implicitly a key factor for precise positioning and for navigation.

One objective of the IGEX experiment was precise orbit determination and validation of GLONASS orbits by laser range observations. In this field, laser based orbit corrections (radial, tangential, and normal) have been systematically computed using a short-arc technique. The orbit corrections have been analyzed as a function of several parameters: date, orbital plane, satellite type and geographical area. The origin of the observed features have tentatively been investigated in terms of: non-gravitational forces, thermal equilibrium of equipment, reference systems, location of the retro-reflectors array. Further investigations will be needed to better understand the origin of various biases.

FACILITIES/SYSTEMS

In 1998, a local geodetic campaign was conducted at Grasse by IGN-F (French National Geographic Institute), to check the distances of all the calibration targets used by the laser stations. The consistency of the methods used is generally at the centimeter or sub-centimeter level, but improvements could still be made. The purpose was also to interconnect all the geodetic instruments, GPS, SLR, LLR, gravimeter. It is important to repeat periodically this kind of local geodetic connection.

A comparison with absolute gravity measurements was performed in 1998. The Geophysics Institute of Strasbourg carried out five campaigns in Grasse. Two reference stations (Grav. 1 and Grav. 2) were chosen to provide a good comparison between several measurements performed at the same period at close locations (the distance between the two points is of about 2 km). One station (Absol. Grav. 1) corresponds to a reference point located near the LLR pillar, and the other one (Absol. Grav. 2) is in a cellar. The variations measured in microGals can be converted in a conventional way into altitude variations ($-0.296 \mu\text{Gal}$ correspond to 3 mm). The agreement between these gravimetric altitude variations and the altitude variations deduced from the laser positioning is quite satisfactory concerning the phase and the amplitude. On the other hand, there is a disagreement with the results obtained by the permanent GPS receiver. This could be due to a tropospheric effect but, there is not enough data to draw strong conclusions. However, it shows the importance of pursuing such experiments to better understand the origin of the observed seasonal variations. To support this work, a permanent DORIS beacon will be set up at the Grasse observatory in 2000-1.

The analysis of LAGEOS data, permanent GPS receiver measurements, and the absolute gravimetry measurements have permitted us to obtain technical improvements, orbitography and positioning quality control, and scientific results. More specifically, the Grasse Lunar Laser Ranging station bias of 9.87

cm, before 1997, has been confirmed by the LAGEOS observations. At the same time, the great stability of its bias since that time (± 1.1 mm), as well as a mean bias very close to zero, have been shown. This data quality is very important for the future and for studying long term time varying phenomena.

FUTURE PLANS

The objective in the near future is to establish a permanent absolute geodetic observatory at Grasse with an absolute reference system (as stable as possible) to permit the control of altitude deviations (instrument, atmosphere) for oceanographic projects such as Jason and ENVISAT, both to be launched in 2000-1.

The SLR and LLR stations are the main systems, but special efforts have been made during the end of the 90s to combine different space geodetic and gravimetric techniques, such as SLR, GPS (Global Positioning System), DORIS (Doppler Orbitography and Radiopositioning Integrated by Satellite), GLONASS (GLOBAL NAVIGATION Satellite System), and an absolute gravimeter FG5. All these techniques are complementary and have a positioning accuracy at 1-2 centimeter or better. The use of these techniques, located in a number of fundamental geodetic stations, is a key factor for improving the absolute accuracy of geodetic products (i.e. positioning, orbit determination) at a global level. The aim of these collocations is also to identify systematics and instabilities in the measurements in order to improve the accuracy of each technique.

The collocation experiment on LAGEOS-1 and -2 will be extended into 2000, using the three laser ranging stations, including the renewed FTLRS.

7.1.2.8 NASA GSFC's/JCET Associate Analysis Center

Erricos Pavlis, *National Aeronautics and Space Administration*

INTRODUCTION

The Associate Analysis Center (AAC) at JCET/GSFC has been slowly coming on line with the activities we had originally proposed to ILRS. The delay is primarily the result of only partial funding of these activities by our sponsors. Despite these problems we have completed a substantial amount of the analysis that we intended to contribute to ILRS this year. We have participated in the IERS/ITRF Pilot Project for TRF definition and the ILRS Pilot Project for site and EOP SINEX file submission. This past year we submitted a preliminary solution to IERS and in 2000 we intend to contribute an iterated version for the new major TRF realization, ITRF2000.

BACKGROUND

The activities of the AAC are primarily focused on the analysis of SLR data from LAGEOS and LAGEOS 2, with analyses for SLR data obtained on additional satellite targets during specific campaigns of interest (e.g. SUNSAT, GPS, GLONASS/IGEX, etc.). The main products are the updated station positions and velocities and the Earth Orientation Parameters (EOP), x_p , y_p , and $LODR$, at daily intervals. In support of the ITRF Pilot Project we also form weekly solutions which are transformed into SINEX format for general distribution. The weekly sets of normal equations are also used to derive a weekly resolution series of "geocenter" offsets from the adopted origin of the reference frame. These se-

ries were used last year to estimate periodic signals at long and intermediate periods, primarily due to the seasonal redistribution of geophysical fluids in the Earth system.

FACILITIES/SYSTEMS

The AAC uses the computing facilities available to the Space Geodesy Branch at NASA Goddard, Code 926. These include a number of workstations, primarily HP 9000/735 and SUN Ultra-5_10, and the Cray J932 parallel processor for the multi-year solutions. The software used is NASA Goddard's GEODYN/SOLVE II package and a number of ancillary s/w used for the data handling/editing and the post-processing of the results.

CURRENT ACTIVITIES

At this time we are completing the combined analysis of the LAGEOS-1 and -2 SLR data set for the period from 1993 to present, in view of the upcoming submission to IERS' ITRF effort for the development of ITRF2000. We continue the generation of weekly solutions as a contribution to the IERS/ITRF Pilot Project and our own activity of monitoring the episodic and seasonal variations in the definition of the geocenter with respect to the origin of the conventional reference frame. We are also re-generating the complete series of the weekly SINEX files for the same period, following the ILRS adopted standards on the basis of the 1999 ILRS Pilot Project. A web site is soon to be operational to aid in disseminating these weekly files and other AAC products.

KEY POINT OF CONTACT

Dr. Erricos C. Pavlis
Joint Center for Earth System Technology, JCET/UMBC
NASA Goddard Space Flight Center
Space Geodesy Branch, Code 926
ESSB Bldg. 33, Rm G213
Greenbelt, Maryland
U S A 20771-0001
Phone: (301) 614-6119
Fax: (301) 614-6099
E-mail: epavlis@Helmert.gsfc.nasa.gov

FUTURE PLANS

In the future we will continue our LAGEOS-related activities with emphasis on the near-real-time generation of weekly products and their dissemination via the web. This year we will start generating a combination product on the basis of GPS and SLR SINEX files. This AAC will also expand its activities to include in its analyses the data of the new geodetic and oceanographic missions to be launched during 2000, CHAMP and JASON. With regard to the second one we have proposed to establish an absolute calibration site at Gavdos, Crete, Greece and in that capacity, we will participate with the SLR data analysis for the CAL-VAL activities during the first six months of the mission.

RELATED PUBLICATIONS

- Pavlis, E. C., "JCET's 1999 SLR-based Terrestrial Reference Frame", *Eos Trans. AGU*, 80(46), Fall Meet. Suppl., F262, 1999.
- Pavlis, E. C., "Error Analysis for LARES", Report to Dept. of Aerospace Engineering, Univ. of Roma 'La Sapienza', Rome, Italy, August, 1999.
- Pavlis, E. C., "Geodetic Constraints on Mass Redistribution in the Earth System", presented at the Joint Symposium *Insights into Earth System Science: Variations in the Earth's Rotation and its Gravitational Field*, at the 22nd General Assembly of the *International Union of Geodesy and Geophysics*, July 19-30, 1999, Birmingham, UK.
- Pavlis, E. C., "LAGEOS 1 and 2 Constraints on Mass Redistribution in the Earth System (1993-98)", presented at the AGU Spring Meeting, *Eos Trans. AGU*, 80(17), Suppl., S84, 1999.
- Pavlis, E. C., "Fortnightly Resolution Geocenter Series: A Combined Analysis of LAGEOS 1 and 2 SLR Data (1993-96)", in *IERS Technical Note 25*, Observatoire de Paris, April 1999.
- Pavlis, E. C., "Geodetic Constraints on Mass Redistribution in the Earth System (1993-1998)", *Geophysical Res. Abstracts*, 1(1), p225, EGS, March, 1999.
- Pavlis, E. C., "Data Analysis for LARES", Report to Dept. of Aerospace Engineering, Univ. of Roma 'La Sapienza', Rome, Italy, March, 1999.

7.1.2.9 IAA Associate Analysis Center

Zinovy Malkin, *Institute of Applied Astronomy of Russian Academy of Science*

INTRODUCTION/DATA PRODUCTS PROVIDED

The IAA (Institute of Applied Astronomy of Russian Academy of Science) Associate Analysis Center began its activity in 1994. It has been routinely processing LAGEOS-1 and -2 observations mainly for use in the IAA EOP Service. Both operational (daily) and final (monthly and yearly) ERP solutions are available on a regular basis.

Beginning from the IERS AR 1995, IAA final SLR submissions are used in the IERS CB combined solutions. Beginning in 1995, IAA operational SLR submissions are used in the IERS Bulletin A combination. For final solutions we process all available observations. Two final solutions are computed. The series EOP(IAA)L01 is computed using LAGEOS-1 observations only (from January 1983), and the series EOP(IAA)L02 is computed using LAGEOS-1 and -2 observations (from October 1992).

Due to limited resources, station coordinates and velocities are not adjusted regularly but are adopted from the IERS (now ITRF97).

FACILITIES/SYSTEMS

Three packages are used in the IAA (or planned for use) for processing of the SLR observations.

The program package GROSS (Geodynamics, Rotation of the Earth, Orbit determination Searching Software) developed by Z. Malkin is the main IAA package used for routine analysis of the SLR observations. It provides both multiarc and multisatellite solutions. The package is operated on a Pentium PC

under MS DOS software windows. The last version of GROSS meets IERS Conventions (1996). As an extension of the IERS Conventions, ocean loading in site displacement is computed using the CSR 3.0 model with a correction for the center of mass displacement computed by H.-G. Scherneck.

Operational calculations of EOP are being made automatically every day. Software used for operational computations includes both MS DOS software windows (GROSS, data formatting, supplement service programs, archiving of results) and Unix (data exchange with world databases and analysis centers, ftp functions, etc.) components.

The software works as follows. Observational data and other relevant files from the Data Centers are automatically downloaded onto the Unix machine. GROSS picks up these data as an everyday scheduled task. Upon the completion of the computations the resulting file is transferred to the Unix machine to be automatically sent to users. In parallel, EOP files for general IAA use are updated along with corresponding data base on Windows and Unix machines. These data are also available via anonymous ftp.

Before and during computation GROSS quality controls input data to prevent submission of incomplete or incorrect data. Some configuration parameters needed for GROSS are also automatically adjusted to the amount and quality of input data.

A special operational strategy for calculations of EOP has been developed to limit the gap between the last observation and epoch of operational EOP to about 2 days (depends chiefly on availability of observational data in CDDIS).

To estimate UT, a free-running UT series is developed for the whole interval of observations and then it is corrected for long-term variations (with periods greater about half of a year) derived from comparison with the EOP (IERS) C04 series.

ERA (Ephemeris Research in Astronomy) is a problem-oriented programming system for ephemeris astronomy developed by the group of G. Krasinsky. The system is designed to support scientific research in astronomy and space science (ephemeris predictions, simulation of observation programs, comparison of positional observations with dynamic theories, etc.). ERA is operated on a PC under MS DOS. ERA supports ephemerides of all Solar system bodies, lunar and planet landers, artificial Earth satellites, and spacecraft.

This group has been developing algorithms and software for combined (on the observational level) processing of SLR and VLBI observations. The main goal is to use SLR data for densification of weekly UT1 and nutation series obtained from VLBI and to produce final daily series containing all five EOP.

The GRAPE package is intended for processing of the microwave and laser range observations of the GPS and GLONASS satellites. It consists of two main parts. The first part is based on the ITALAS package developed at the Institute of Theoretical Astronomy (which joined IAA in 1998) by the group Iskander Gayazov. It is used for preparation of satellite ephemerides used in the main part of the GRAPE package. The main part of the package was developed in Delphi under Windows.

This package uses third differences of phase observations for evaluation of satellite orbits, Earth Rotation Parameters (ERP), station coordinates and zenith troposphere delays. Some original algorithms for determination of cycle slips, phase ambiguities and troposphere delay modelling are used in the GRAPE package. At the moment only GPS observations are processed with GRAPE package. ERA and GRAPE packages operate on Pentium PC.

CURRENT ACTIVITIES

IAA Associate Analysis Center continues to:

- Regularly submit EOP operational and final solutions to the IERS.
- Develop the GROSS package, mainly for implementing advanced algorithms for the combination of SLR, GPS and VLBI EOP series.
- Develop ERA packages for combined processing of the SLR and VLBI observations. In 1999 the first yearly ERP series was produced using only SLR data and the first experimental combination SLR+VLBI results were obtained.
- Develop GRAPE package for processing of the microwave and laser range observations from GPS and GLONASS satellites. Experimental computation of orbits and ERP in a real-time regime (using GPS observations only) was begun and shows good quality results. The addition of microwave GLONASS and laser range observations on the GPS and GLONASS satellites are planned for 2000-2001.
- In 1999 the IAA AAC took part in the ILRS Analysis Working Group pilot project. Two ERP solutions obtained with GROSS and ERA packages and station position solution obtained with ERA package was submitted to the ILRS Analysis WG.

KEY POINTS OF CONTACT

IERS and ILRS related matters, EOP Service, GROSS package:

Zinovy Malkin malkin@quasar.ipa.nw.ru

GPS/GLONASS/SLR observations, ITALAS, GRAPE packages:

Iskander Gayazov gayazov@quasar.ipa.nw.ru

SLR/VLBI observations, ERA package

Nadejda Shuygina nvf@quasar.ipa.nw.ru

FUTURE PLANS

For 2000-2001 we plan to:

- Continue to regularly submit EOP operational and final solutions to the IERS and ILRS.
- Begin to regularly compute (fully independent of IERS data) EOP solutions based on a combination of SLR, GPS and VLBI data.
- Combine the microwave GLONASS and laser range observations on GPS and GLONASS satellites in 2000-2001.
- Begin to regularly produce station position and GPS/GLONASS orbit solutions (SLR only, GPS/GLONASS only and combined).

7.1.2.10 AIUB Associate Analysis Center

Tim Springer, *Astronomical Institute, University of Berne*

INTRODUCTION

The Center for Orbit Determination in Europe (CODE) is one of the Analysis Centers of the International GPS Service (IGS). CODE, located at the Astronomical Institute of the University of Berne, is a joint venture of the following institutes:

- Swiss Federal Office of Topography (L+T),
- French "Institute Geographique National" (IGN),
- German "Bundesamt fuer Kartographie and Geodaesie" (BKG), and
- Astronomical Institute of the University of Berne (AIUB).

Besides being one of the Analysis Centers of the IGS, CODE is also one of the Analysis Centers of the International GLONASS Experiment (IGEX), and one of the Associate Analysis Centers (AAC) of the International Laser Ranging Service (ILRS). In its role as AAC of the ILRS, CODE has provided (since December 1996) the SLR-GPS quick-look service using the SLR observations taken from the two GPS satellites PRN 5 and PRN 6. CODE also provides orbit predictions for all GPS and GLONASS satellites. These predictions are converted to IRVs by RGO and used by several of the (European) SLR tracking stations.

At CODE the main motivation to use the SLR observations for the GPS (and GLONASS) satellites is that these observations provide a unique opportunity to validate the quality of the IGS (and IGEX) orbit estimates. Because the IGS (and IGEX) orbits are based on microwave measurements only, the SLR observations provide a completely independent validation of the orbit quality. Due to the high altitude of the GPS satellites, the angle between the vector from the SLR observatory to the GPS satellite and the vector from the geocenter to the GPS satellite is 14 degrees at maximum. The SLR observations are therefore nearly in the radial direction, and thus provide mainly information concerning the radial orbit errors.

The orbit validation is based on the difference between the observed range (the SLR normal point measurement) and the computed range. The range is computed assuming both, the SLR station positions and the GPS satellite positions, are known. The SLR station positions are taken from the latest ITRF realization, whereas the orbit positions may be obtained from the IGS, in our case, the orbits of the CODE analysis center. The tropospheric delays are modeled using the Marini-Murray model in which the temperature, pressure, and humidity measurements, delivered with the SLR normal points, are introduced.

BACKGROUND

Besides the quick-look service we have analyzed all of the SLR observations from the GPS satellites observed in the time span from January 1995 to July 1999, and for the GLONASS satellites observed in the time span from day 283 in 1998 (start of the IGEX campaign) until day 149 in 1999.

The results of these OMC (Observed Minus Computed) analysis revealed that there is an average bias between the observed and computed SLR ranges! The bias estimate being -55 mm based on the GPS

data and -42 mm based on the GLONASS data. The negative sign indicates that the observed SLR ranges are shorter than the computed ranges.

Secondly, the RMS of the OMC residuals, around the mean, is as low as 55 mm for the GPS data and 128 mm for the GLONASS data. This result is truly remarkable. It implies that the two independent techniques, microwave and SLR, agree at the level of a few centimeters. Most importantly it also shows that the (radial) orbit error of the IGS orbits is as small as 55 mm. This corresponds quite well to the RMS statistics of the weekly IGS orbit combinations. The higher RMS for the GLONASS results is caused by the lower quality of the IGEX orbits compared to the IGS orbits. This difference is mainly explained by the fact that the GLONASS microwave tracking network is quite poor compared to the current status of the IGS network. Considering this important limitation, the GLONASS orbits are in fact of a remarkable quality.

The fact that the observed bias is so similar for both satellite systems practically rules out the possibility of an error in the SLR reflector offset because it is unlikely that a similar error was made in computing the center of mass correction for the retroreflector arrays on both systems. We should note, however, that the GLONASS orbits are derived by fixing the GPS orbits. Therefore, the GLONASS orbits are not independent from the GPS orbits and the same might be true for the observed bias. We should also point out that the retroreflector arrays on both systems are very similar, the only difference being the size of the GPS and GLONASS retroreflector arrays. The observed bias might thus have something to do with the reflectors. However, given the small size of the reflectors, (height of only 37 mm) a 50 mm error is hard to imagine.

More information about this study may be found in "Modeling and Validating Orbits and Clocks Using the Global Positioning System."¹

Besides orbit validation, the SLR observations may also be used to study the attitude of the GPS satellites as a function of time during their eclipse phases. Furthermore, the combination of the observations from different techniques, microwave and SLR, will unify the terrestrial reference frame for both techniques and may lead to improved orbits of the microwave satellites. The unification of the terrestrial reference frame will be of advantage for all parameters common to both techniques, i.e., Earth rotation, station coordinates, and geocenter.

CURRENT ACTIVITIES

At CODE we monitor the SLR observations using our IGS rapid and final orbits. Because our daily IGS rapid orbits are available around 12:00 UTC, only 12 hours after the end of the observation day, they provide the possibility of giving very rapid feedback on the quality of the SLR observations. Because we think that this rapid turn-around is very useful for the SLR tracking stations, we have set up the SLR-GPS quick-look service.

Each day the SLR observations gathered over the last 6 days are evaluated using the CODE IGS Orbits. The last 4 days are analyzed using the CODE rapid orbits. The 2 older days are analyzed using the CODE final Orbits. The final orbits have an estimated precision of about 50 mm whereas the rapid orbit precision varies between 50 and 150 mm. The SLR-GPS quick-look results, covering 6 days, are distributed by e-mail every day provided that new data was available. Table 7.1.2.10-1 shows an example of the SLR-GPS quick-look report. Note that, in these reports, the "MEAN" will absorb possible range biases, to a large extent possible time biases, and part of the GPS orbit error. The "RMS" (around the mean) gives a reasonable representation of the noise of the SLR observations. However, in cases where a satellite eclipse event was tracked, the RMS will be larger than the noise of the observations. Furthermore, for long passes, the satellite orbit error will start to show up in the RMS.

<i>Station ID</i>	<i>SAT PRN</i>	<i>Start Passage</i>		<i>Dur (min)</i>	<i>#OBS GOOD</i>	<i>MEAN (mm)</i>	<i>RMS (mm)</i>	<i>#OBS BAD</i>	<i>MEAN (m)</i>	<i>RMS (m)</i>
		<i>yy/mm/dd</i>	<i>hh:mm</i>							
7080 MLRS	6	00/03/01	02:47	7	3	-41	9			
7080 MLRS	6	00/03/03	01:14	157	8	-52	20			
7080 MLRS	6	00/03/06	02:29	22	6	-21	3			
7090 YARR	6	00/03/01	16:23	7	3	-135	0			
7090 YARR	6	00/03/03	18:28	143	9	-16	20			
7090 YARR	6	00/03/05	15:39	186	10	-61	15			
7090 YARR	6	00/03/06	16:10	125	5	-70	14			
7090 YARR	5	00/03/01	15:33	42	6	-54	6			
7090 YARR	5	00/03/03	18:09	7	3	-44	2			
7090 YARR	5	00/03/08	15:09	196	11	-38	8			
7090 YARR	5	00/03/06	13:39	211	9	-66	49			
7849 MSTR	6	00/03/01	19:13	24	5	-59	5			
7849 MSTR	6	00/03/02	18:32	61	8	-56	5			
7849 MSTR	6	00/03/05	18:52	24	3	-50	4			
7849 MSTR	5	00/03/01	15:52	25	6	-53	12			
7849 MSTR	5	00/03/02	17:28	34	5	-110	8			
7845 GRASSE	6	00/03/02	10:18	134	6	-10	8			
7845 GRASSE	6	00/03/03	11:14	12	4	0	4			
7845 GRASSE	6	00/03/06	10:14	126	7	5	45			
7845 GRASSE	5	00/03/02	09:54	9	3	-47	7			
7845 GRASSE	5	00/03/03	07:59	11	4	-67	3			
7845 GRASSE	5	00/03/06	08:39	11	4	-123	8			
7839 GRAZ	6	00/03/06	12:02	24	6	27	3			
					134	-46	39		0.0%	
<i>Station ID</i>	Station CDP number and first 4 characters of the station name									
<i>SAT PRN</i>	The GPS Pseudo Random Noise (PRN) number (5 or 6 for SLR)									
<i>Start Passage</i>	Start time of the SLR observation pass									
<i>Dur</i>	Duration of the SLR observation pass									
<i>#OBS GOOD</i>	Number of accepted SLR observations.									
<i>MEAN</i>	Mean of the OMC residuals (in millimeters)									
<i>RMS</i>	RMS of the OMC residuals around the MEAN (in millimeters)									
<i>#OBS BAD</i>	Number of rejected SLR observations (OMC > 1 meter).									
<i>MEAN</i>	Mean of the BAD OMC residuals (in meters)									
<i>RMS</i>	RMS of the BAD OMC residuals around the MEAN (in meters)									

Table 7.1.2.10-1: SLR-GPS quick-look report day 066, 2000

FUTURE PLANS

In the near future we hope to integrate data from the GLONASS satellites into our routine IGS processing. This will enable us to include the SLR data from the GLONASS satellites in our quick-look service. Because all GLONASS satellites are equipped with an SLR reflector array and are relatively easy to track, this will provide a useful enhancement of the present quick-look service.

REFERENCES

¹ "Modeling and Validating Orbits and Clocks Using the Global Positioning System," T.A. Springer, Ph.D. Thesis, University of Berne

7.1.2.11 BKG Associate Analysis Center

Bernd Richter, *Bundesamt für Kartographie und Geodäsie*

INTRODUCTION

Central task of the Bundesamt für Kartographie und Geodäsie (BKG) geodetic division is to provide and update the Geodetic Reference Networks of the Federal Republic of Germany including:

- Survey work (Station Wettzell - SLR, VLBI, GPS, GLONASS observations, survey campaigns, and other activities), and theoretical work for collection and preparation of survey data;
- Cooperation in bilateral and multilateral activities for definition and updating of global reference systems;
- Further development of the survey and observation technology used;

Representation of the relevant interests of the Federal Republic of Germany on an international level.

The BKG Associate Analysis Center routinely processes LAGEOS-1 and -2 data for satellite orbit determination, station coordinates, Earth Orientation Parameters and SLR station performance monitoring. In addition, special investigations have been made to study new laser ranging systems by collocation (e.g. TIGO) and to support the GLONASS IGEX campaign.

FACILITIES/SYSTEM

The available computation facilities in the BKG Potsdam Branch consist of HP workstations. Orbit and parameter estimations (station coordinates and EOP) are performed with UTOPIA (CSR, University of Texas). Moreover the BERNESE Software Engine is used for the network combination of various space techniques. In-house programs have been developed for station coordinate transformations, EOP series generations and to create updated SINEX files.

CURRENT ACTIVITIES

The BKG contributes to the ILRS Analysis Working Group pilot projects with respect to station coordinates and EOPs.

On an annual basis, station coordinates, velocities and EOPs are provided to the IERS office (in particular for the ITRF 2000).

The BKG solutions are no longer constrained by fixing parameters but rather by using a-priori sigmas to characterize the datum.

FUTURE ACTIVITIES

The BKG will continue its participation in future ILRS and IERS Time Series pilot projects. On a regular basis orbit determinations, positions, velocities, EOP solutions, geo-center and GM variations will be contributed to the IERS and other services.

7.2 LUNAR LASER RANGING

Lunar Analysis Centers process normal point data from the Lunar Laser Ranging (LLR) stations and generate a variety of scientific products including precise lunar ephemerides, librations, and orientation parameters which provide insights into the composition and internal makeup of the Moon, its interaction with the Earth, tests of General Relativity, and Solar System ties to the International Celestial Reference Frame.

7.2.1 INTRODUCTION

Peter Shelus, *University of Texas*

In the simplest of terms, lunar laser ranging (LLR) is a modern and exotic form of astrometry. It consists of accurately measuring the round-trip travel time for a laser pulse that is emitted from an observing station on the Earth and returns, after being reflected off of a retroreflector array on the surface of the Moon. The analysis of this constantly changing distance, using several observatories on the Earth and several retroreflectors on the Moon, provides for a wide spectrum of terrestrial, lunar, solar system, and relativistic science [Bender *et al.*, 1973; Mulholland, 1980; Dickey *et al.*, 1994]. But, even after more than 30 years of operation, LLR remains a non-trivial and technically challenging task. Signal loss, caused mainly by the inverse 4th power of the Earth-Moon distance but also the result of optical and electronic inefficiencies in the observing equipment, requires the detection of single photoelectron events. With the present laser firing rate of 10 hertz, at a station like the MLRS, fewer than 25 photoelectrons/minute are routinely obtained. Timing precision is measured in ten's of picoseconds with the total range accuracy being about an order of magnitude larger. Were the moon to be just 25% farther from the Earth than it is, this experiment probably could not be performed with present equipment. It is quite sobering to realize that it is more than a trillion times more difficult to range to the Moon than it is to range to Topex-Poseidon. At the present time, even though there are several tens of highly efficient artificial satellite ranging stations around the world, only two of them have the capability of ranging to the Moon. One of them is located in the United States, at McDonald Observatory. The other is in the south of France, near Nice, at the Observatoire de la Cote d'Azur.

The basic data that is gathered by LLR forms the foundation upon which a large number of astronomical disciplines depend. They provide for an invaluable multi-disciplinary analytical tool, the benefits of which are registered in such areas as the solid Earth sciences, geodesy and geodynamics, Solar System ephemerides, terrestrial and celestial fundamental reference frames, lunar physics, general relativity and gravitational theory. They contribute to our knowledge of the precession of the Earth's spin axis, the 18.6 year lunar induced nutation, polar motion and Earth rotation, the determination of the Earth's obliquity to the ecliptic, the intersection of the celestial equator and the ecliptic (the equinox), lunar and solar solid body tides, lunar tidal deceleration, lunar physical and free librations, as well as energy dissipation in the lunar interior. They determine Earth station and lunar surface retroreflector location and motion, the Earth-Moon mass ratio, lunar and terrestrial gravity harmonics and Love numbers, relativistic geodesic precession and the strong equivalence principle of general relativity.

REFERENCES

- Bender, P. L., Currie, D. G., Dicke, R. H., Eckhardt, D. H., Faller, J. E., Kaula, W. M., Mulholland, J. D., Plotkin, H. H., Poultney, S. K., Silverberg, E. C., Wilkinson, D. T., Williams, J. G., and Alley, C. O., 1973, *Science*, 182, 229.
- Dickey, J. O., Bender, P. L., Faller, J. E., Newhall, X X, Ricklefs, R. L., Ries, J. G., Shelus, P. J., Veillet, C., Whipple, A. L., Wiant, J. R., Williams, J. G., and Yoder, C. F. 1994, *Science*, 265, 482.
- Mulholland, J. D., 1976, *Sci. Appl. of LLR*, (J. D. Mulholland, Ed.), Reidel, Dordrecht, Netherlands, 9.

7.2.2 ANALYSIS CENTERS

7.2.2.1 PARIS OBSERVATORY

Bernd Richter, *Bundesamt für Kartographie und Geodäsie*

INTRODUCTION

Paris Observatory Lunar Analysis Center (POLAC) is located in the Department of Fundamental Astronomy at the Paris Observatory and works in cooperation with the CERGA LLR team at Grasse, France. Its goals are to improve the analytical solutions of the orbital and rotational motions of the Moon, to determine the orientation of the ecliptic and to produce Universal Time series UT0-UTC.

BACKGROUND

For many years our team has been involved in celestial mechanics studies, especially in the development of analytical solutions of lunar and planetary motions for the publication of solar system bodies ephemerides. Since 1997, we have cooperated with IERS in the determination of the ecliptic dynamical celestial reference frame, and we now produce Earth rotation parameters.

FACILITIES

The computing equipment consists of individual microcomputers connected to the DANOF local network (UNIX system), the entire computer background being managed by the Data Processing Department of the Paris Observatory. The two operational LLR stations, Grasse (France) and McDonald (Texas), send us their observations directly by e-mail.

ACTIVITIES

LLR stations provide normal points which can be considered as observations of the light time between a terrestrial transmitter, a lunar reflector and a receiver on Earth. The LLR stations providing data for our analyses are: McDonald, Texas (3 different locations over the span 1969-1999); Grasse, France (2 successive instruments at the same location over the span 1984-1999); and Mount Haleakala, Hawaii (over the span 1987-1990). The lunar reflectors are Apollo 11, Apollo 14, Apollo 15 and Lunakhod 2.

Two kinds of analyses have been performed:

- Global analyses of all the observations available from January 1972 till March 1999. They have allowed us to fit several lunar motion parameters, and the orientation of the mean ecliptic of J2000.0 with respect to the mean Celestial Ephemeris Pole (MCEP) of J2000.0 and to the International Celestial Reference System (ICRS);
- Nightly analyses, using the results of the global analyses, for the determination of Earth orientation parameters. Values of UT0-UTC and Variation Of Latitude (VOL) have been estimated from January 1995 through December 1998 using the observations of the two active LLR stations: McDonald (MLRS) and CERGA (Grasse).

Basis of the analyses

We use the solution ELP2000-96 for the orbital motion of the Moon. It results from the improved analytical theory ELP2000-82B plus numerical complement fit to the numerical integration DE245 (JPL, Pasadena, USA) as described in [Chapront and Chapront-Touzé, 1997]. The adopted solution of the libration is Moons' theory [1982, 1984] with analytical and numerical complements as described in [Chapront et al., 1999a]. Both solutions are referred to the mean ecliptic of J2000.0 in the inertial sense as defined by Standish [1981]. In the global analyses, these solutions allow to fit orbital parameters of the Moon including the tidal secular acceleration, parameters of the free libration, and parameters of the Earth-Moon barycenter motion.

The selenocentric coordinates of the lunar reflectors are fit in the global analyses. The coordinates of the LLR stations in the International Terrestrial Reference System (ITRS) are derived from ITRF94 [Boucher et al., 1996] in the global analysis, and ITRF96 [Boucher et al., 1998] in the nightly analyses. They are corrected for the Earth's deformations due to tides and pressure anomalies following the recommendations of the IERS Standards 1992 [McCarthy, 1992].

In the global analyses, the transformation from the terrestrial coordinates of the stations (ITRS) to their instantaneous equatorial celestial coordinates is computed with the IERS values (x, y, UT1) of the Earth Orientation Parameters (EOP series C04). In the nightly analyses the transformation is expressed by means of two fitted parameters UT0 and VOL. In both cases, a relativistic correction for the conversion of space coordinates in a terrestrial reference system (TCG time coordinate) to space coordinates in a barycentric system with TDB time coordinate [Martin et al., 1985], is added. The short period variations in x, y, and UT1-UTC are taken into account by Ray's method [McCarthy, 1996].

In the nightly analyses and in the global analyses yielding the orientation of the ecliptic with respect to the MCEP of J2000.0, the rotation from the celestial instantaneous axes to fixed celestial equatorial axes uses analytical theories of the precession and nutation. The precession is given by the expressions of Williams, [1994] with corrections to the precession and obliquity constants introduced by means of the derivatives of Simon et al., [1994]. Those corrections are fitted parameters in the global analyses. The difference between the actual value of the precession constant and the IAU 1976 value is introduced in the expression of the Greenwich Sidereal Time [Aoki et al., 1982], following the conclusions of Williams and Melbourne, [1982]. The ZMOA 1990 solution [Herring, 1991] is adopted for the nutation. In the analyses yielding the orientation of the ecliptic in the ICRS, the precession is given by the IAU 1976 expressions [Lieske et al, 1977] and the nutation is computed by adding to the IAU 1980 expressions [Seidelman, 1982] the corrections $d\psi$ et $d\epsilon$ provided by IERS (EOP series C04).

The rotation from celestial equatorial coordinates to ecliptic coordinates involve two parameters: ϵ , the inclination of the inertial mean ecliptic of J2000.0 (fixed by ELP 2000-96) on the equatorial reference plane, and ϕ , the angle separating γ_{2000}^I (the ascending node of the ecliptic on the equatorial reference

plane) from the origin γ of right ascensions in the equatorial reference plane. γ_{2000}^J is the origin of longitudes in the ecliptic. The positions of the equatorial reference plane and γ result from the terrestrial coordinates of the LLR stations and their transformation to celestial equatorial coordinates. So do ϵ and ϕ , which are fit in the global analyses, and γ_{2000}^J .

In all the analyses, we take into account the relativistic time scale correction between the dynamical barycentric time TDB and the Terrestrial Time TT [Fairhead and Bretagnon, 1990]. The relativistic deflection of the light propagation in the frame of the General Relativity theory is given by an approximate formula [Chapront et al., 1999b]. We use the tropospheric corrections formulated by [Marini and Murray, 1973]. A correction of 0.7 ns has been added to CERGA observations from 1997/01/13 till 1998/06/24 in order to take into account a calibration offset mentioned by F. Mignard and J.F. Mangin (CERGA).

Results of the global analyses

We give here the results obtained in 1999 for the orientation of the inertial mean ecliptic of J2000.0 with respect to the frame tied to the mean Celestial Ephemeris Pole of J2000.0 (MCEP) and to the International Celestial Reference System (ICRS).

$$\begin{aligned} \epsilon(\text{MCEP}) &= 23^\circ 26' 21.40532'' \pm 0.00007'' & \phi(\text{MCEP}) &= -14.9 \text{ mas} \pm 0.3 \text{ mas} \\ \epsilon(\text{ICRS}) &= 23^\circ 26' 21.41096'' \pm 0.00006'' & \phi(\text{ICRS}) &= -56.7 \text{ mas} \pm 0.2 \text{ mas} \end{aligned}$$

The separation between the two origins of longitude, derived from the comparison of the fitted lunar mean longitudes at the mean epoch of observations, is

$$\gamma_{2000}^J(\text{ICRS}) - \gamma_{2000}^J(\text{MCEP}) = 45.4 \text{ mas} \pm 0.6 \text{ mas.}$$

$\gamma_{2000}^J(\text{MCEP})$ is the inertial dynamical mean equinox of J2000.0.

The fitted correction to the IAU 1976 value of the precession constant is:

$$\Delta p = -3.43 \pm 0.4 \text{ mas/yr.}$$

The post-fit residuals RMS over the time span 1987-1999 is estimated to 0.33 nanosecond for the light time "transmitter-reflector-receiver", which corresponds to an accuracy of about 5 cm for the one way range station-reflector.

As an example, Figure 7.2.2.1-1 shows the LLR CERGA residuals for the time span 1995-1998.

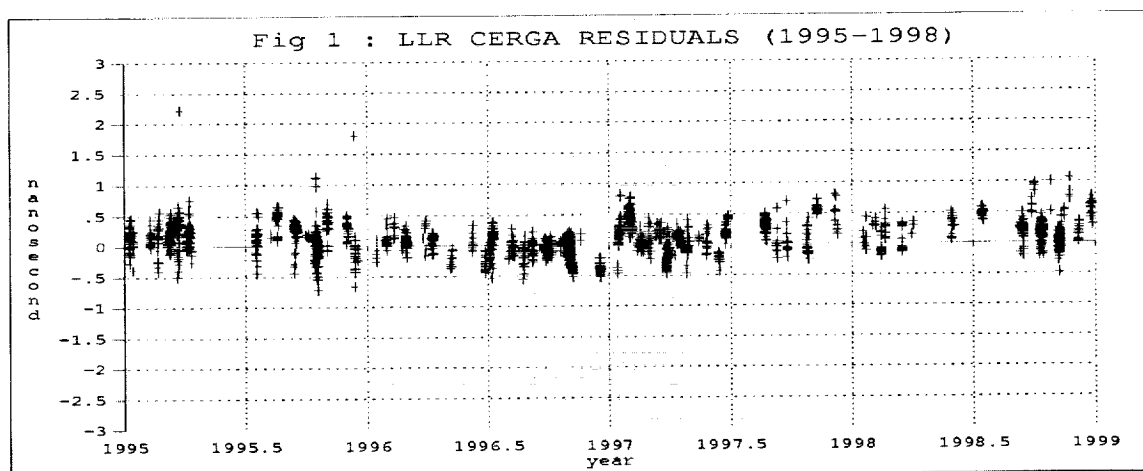

Figure 7.2.2.1-1 Determination of UT0-UTC and VOL

This determination is based on the analysis of a set of 2146 LLR observations (normal points) from Grasse (CERGA) and 1442 observations from McDonald (MLRS2) covering the time span from January 1995 till December 1998. The adopted coordinates of LLR stations, MLRS2 and CERGA, were derived from ITRF96 coordinates of the SLR stations at the same sites.

Disregarding negligible second order quantities, the determination of UT0-UTC and VOL are tied to the Earth rotation parameters UT1-UTC, x and y by the relations :

$$UT0-UTC = UT1-UTC + (x \cdot \sin(\lambda) + y \cdot \cos(\lambda)) \cdot \tan(\phi) / (15 \cdot 1.002737909)$$

$$VOL = x \cdot \cos(\lambda) - y \cdot \sin(\lambda)$$

UT1-UTC is measured in second of hour; (x, y) in second of degree; λ is the station east longitude and ϕ is the geocentric latitude.

The couple of values (UT0-UTC, VOL) are determined by station and by reflector for the mean date of each night of observation. They are derived from the differences between observed and computed light times for each night/reflector by the least squares method with two iterations. No weights are assigned to the observations. The Apollo 15 reflector is the major contributor to the determination.

In the analysis, no *a priori* EOP values are introduced, but we take into account the variations of UT0-UTC and VOL during the night with the aid of approximate values of their derivatives estimated from IERS EOP during the previous lunation. We have rejected data from individual reflectors with less than 4 observations and those with just 4 observations in a night over a span shorter than 1.5 hour. We have also disregarded the results with formal uncertainties larger than 1 ms for UT0-UTC and 20 mas for VOL. These last circumstances are very rare.

Our numerical experiences show that an annual fitting of the lunar solution is sufficient to maintain this precision. Over the time span: 1995-1998, 323 values of (UT0-UTC, VOL) were produced, 172 values from CERGA observations and 151 values from MLRS observations. Figure 7.2.2.1-2 shows the differences between the UT1-UTC deduced from POLAC values (UT0-UTC, VOL) and those edited by IERS (EOP Series C04).

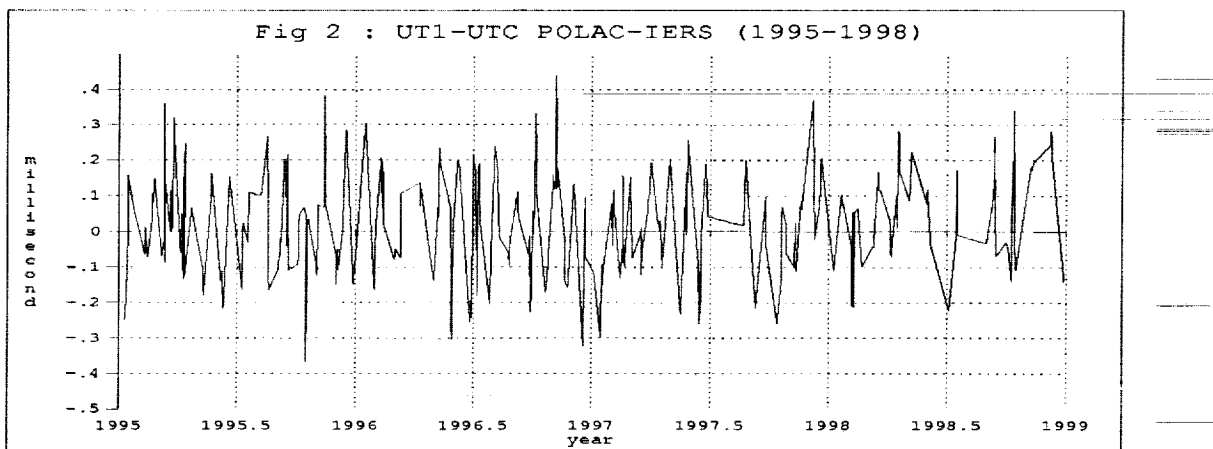

Figure 7.2.2.1-2 The precision of the determination is about 0.20 ms for UT0-UTC and 3.0 mas for VOL.

REFERENCES

Aoki S., Guinot B., Kaplan G.H. et al., *Astron. Astrophys.*, 105, 359, 1982.

Boucher C., Altamini Z., Feissel M., Sillard P., IERS Technical Note n°20, Paris Obs, 1996.

- Boucher C., Altamini Z., Sillard P., IERS Technical Note n°24, Paris Obs, 1998.
- Chapront, J., Chapront-Touzé, M., Celest. Mech. 66, 31, 1997.
- Chapront, J., Chapront-Touzé, M., Francou, G., Celest. Mech. 73, 317, 1999a.
- Chapront, J., Chapront-Touzé, M., Francou, G., Astron. Astrophys. 343, 624, 1999b.
- Fairhead L., Bretagnon P., Astron. Astrophys., 229, 240, 1990.
- Herring, T.A., Proceedings of the 127th Colloquium of the IAU, J. A. Hughes, C.A. Smith and G.H. Kaplan eds, USNO, Washington D.C., p.157, 1991.
- Lieske J.H., Lederle T., Fricke W., Morando B., Astron. Astrophys. 58, 1, 1977.
- McCarthy D. D., IERS Technical Note n°13, Paris Obs, 1992.
- McCarthy D. D., IERS Technical Note n°21, Paris Obs, 1996.
- Marini, J.W. and Murray, C.W., NASA GSFC X-591-73-351, 1973.
- Martin C.F, Torrence M.H., Misner L.W., J. Geophys. Res., 90, 9403, 1985.
- Moons M., The Moon and the Planets, 27, 257, 1982.
- Moons M., Celest. Mech., 34, 263, 1984.
- Seidelmann P.K., Celest. Mech.. 27, 79, 1982.
- Simon, J.L., Bretagnon, P., Chapront, J., Chapront-Touze, M., Francou, G., Laskar, J., Astron. Astrophys. 282, 663, 1994.
- Standish, E. M., Astron. Astrophys. 101, L17, 1981.
- Williams, J.G., Melbourne, W.G., O. Calame ed., High precision Earth precision and Earth-Moon dynamics, Reidel Publ. Comp., Dordrecht, p.283, 1982.
- Williams, J.G., Astron. J. 108, 711-124, 1994.

KEY POINTS OF CONTACT

Authors: Jean Chapront, Michelle Chapront-Touze, Gerard Francou, Patrick Bidart
Address: Observatoire de Paris - Danof, 61 avenue de l'Observatoire, 75014 Paris, France
Contact: jean.chapront@obspm.fr
Server: Anonymous Ftp - danof.obspm.fr (directory: /pub/polac).

FUTURE PLANS

We shall continue to develop the lunar solutions. We plan to introduce the complete models recommended by the IERS Conventions of 1996, and expect to produce regularly values of UT0-UTC and VOL.

7.2.2.2 FESG/TUM

Jurgen Mueller, *Forschungseinrichtung Satellitengeodäsie*

INTRODUCTION/DATA PRODUCTS PROVIDED

At the FESG (Forschungseinrichtung Satellitengeodäsie = Research Facility for Space Geodesy), LLR data are analyzed once per year to provide a Set of Station Coordinates (SSC) in SINEX format as well as Earth Orientation Parameters (EOP) for the annual contribution to the ITRF_{xx} and the IERS annual report, respectively. When solving for these parameters, a set of about 170 model parameters (without the EOPs) are estimated simultaneously in a so-called global standard solution. Thereby, the investigation of relativistic effects is of special importance.

Besides this routine procedure, further effects are investigated upon request, e.g. the correlation of some tidal parameters like h_2 or l_2 with the relativistic quantities (e.g. with the equivalence principle or Nordtvedt parameter η).

The parameter determinations are always based upon all LLR data available since 1970, about 13500 normal points which have an accuracy of about 1 cm in the Earth-Moon distance. The advantage of using data covering such a long time span (about 30 years) is that one is able to solve also for secular (e.g. the time variation of the gravitational constant dG/dt G^{-1}) and long periodic quantities (e.g. the coefficients of the 18.6 years nutation period). More details can be found in *Müller et al.* [1999].

BACKGROUND

The analysis of LLR observations started in the early 1980's when the basic modules of the LLR software were developed at the FESG. The whole software was intended to be consistent with Einstein's theory of gravity up to the first post-Newtonian level. In the Nineties, this software package was extended to be consistent with the *IERS Standards* [1989/1992] and the *IERS Conventions* [1996].

The main processes necessary for LLR analyses are the following ones:

- once per year (mostly in spring) the lunar observations from the last year are added and outliers eliminated;
- one software module computes the ephemerides of the main solar system bodies like Sun, Earth, Moon, planets and the major asteroids, covering the whole period since 1969 with intervals of about 8 hours;
- a second computer program calculates the dynamical partials, i.e. those which depend on the position of Earth, Moon and Sun (by far the most time consuming module);
- a third program performs the global parameter adjustment where improved values of the unknowns and the corresponding formal standard errors are obtained;
- the determination of VOL (variation of latitude caused by polar motion) and Earth rotation UT1 is performed by an additional module after the global parameter adjustment. There the post-fit residuals are analyzed.

Normally, the results can be improved by iterating steps b) through e) which is necessary because of the non-linear coupling of many model parameters (Figure 7.2.2.2-1 shows the post-fit residuals for 1999 where the final adjustment of VOL and UT1 was not performed yet).

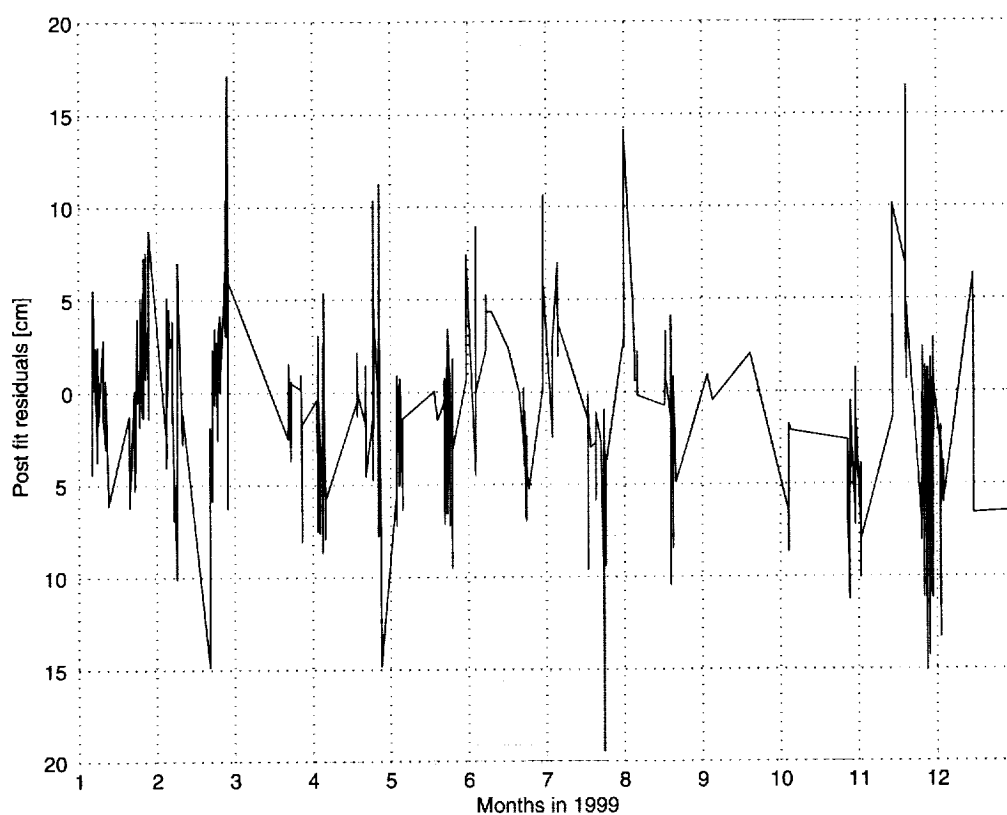

Figure 7.2.2.2-1: Post-fit residuals for 1999. The RMS is less than 4 cm.

In the global standard solution the solve-for parameters are geocentric coordinates of the observatories, selenocentric coordinates of the reflector arrays, physical librations of the Moon, initial values of the lunar orbit, initial values of the Earth orbit, lunar gravity field up to degree and order 3, the mass of the Earth-Moon system, the Love number of the Moon and a dissipative parameter, the lunar tidal acceleration (responsible for the increase of the Earth-Moon distance of about 3.8 cm/year), a correction to the luni-solar precession constant, the coefficients of the 18.6 years nutation period and others. The EOPs 'VOL' and 'UT1' are computed from the post-fit residuals using the daily decomposition method [Dickey *et al.*, 1985], i.e. correlations with the parameters of the standard solution are neglected. However, a new iteration with these improved EOPs may be started once again.

After the iterative procedure has converged, more tiny effects of special interest are investigated, e.g. quantities parametrizing relativistic effects like metric parameters γ and β , the geodetic precession of the lunar orbit, the Nordtvedt parameter (a test of the strong equivalence principle), the time variation of the gravity constant, the Yukawa coupling constant (a test of Newton's inverse square law for the Earth-Moon distance), the validity of the equivalence principle for dark matter assumed in the center of the galaxy or metric parameters indicating a possible presence of preferred frames or directions (in contradiction to special and general relativity).

FACILITIES/SYSTEMS

The software used for computing steps b) through e) as described in the last section, has been coded in FORTRAN from the very beginning. The main work has been done within three Ph.D. theses, written in German [Gleixner, 1986; Bauer, 1989; Müller, 1991]. The FORTRAN programs are running on a DEC Alpha work station. A C-version of the ephemeris program has also been written. In the last few years, a formulation of the whole LLR analysis package was developed in C⁺⁺. It was coded in another Ph.D.

thesis [Reichhoff, 1999], but could not be completed because our colleague died in April 1999 - a big loss for our group. The latter tool is running on a commonly used PC under UNIX. The standard solutions are presently computed using the FORTRAN software package.

The computer time including the calculation of the dynamical partials (which do not always have to be computed) takes about 1 hour per iteration for the whole period of 30 years, and below 20 minutes without calculating new partials.

CURRENT ACTIVITIES

At the moment, the LLR model is being improved with the help of a graduate student. The solid Earth tide model is being updated using the model of Mathews *et al.* [1997]. Along with the updated model, we are investigating the potential of LLR to determine tidal parameters. The capability of our recent LLR software to obtain a good result of e.g. the Love number h_2 (based upon the old model), is limited because the description of the effect does not consider the frequency-dependence in an appropriate way.

Then the velocities of the continental plates, on which the observatories are located, are estimated, where the best constraining procedure has still to be identified. The goal is to achieve sufficient quality of the LLR products, especially the SSC, that they can be used in the ITRF realizations without difficulty. In the last few years, the overconstraining of site velocities was often the reason for the rejection of the LLR result from the final ITRF solution. When computing the standard solution for the IERS Annual Report, the relativistic parameters are also estimated. In our most recent solution, given in Table 7.2.2.2-1, the realistic errors are indicated. These exceed the formal errors by a factor of 2 to 10, depending on the parameter.

Parameter	Results
difference of geodetic precession $\Omega_{GP} - \Omega_{deSit}$ ["/cy] (1.92 "/cy predicted by Einstein's theory of gravitation)	$(-2 \pm 10) * 10^{-3}$
metric parameter $\gamma - 1$ (space curvature; $\gamma = 1$ in Einstein)	$(4 \pm 5) * 10^{-3}$
metric parameter $\beta - 1$ (non-linearity; $\beta = 1$)	$(-1 \pm 4) * 10^{-3}$
Nordtvedt parameter η (violation of the strong equivalence principle)	$(8 \pm 9) * 10^{-4}$
time variable gravitational constant dG/dt G^{-1} [yr^{-1}] (-> unification of the fundamental interactions)	$(3 \pm 5) * 10^{-12}$
Yukawa coupling constant $\alpha_{\lambda=4*10^5 km}$ (test of Newton's inverse square law for the Earth-Moon distance)	$(2 \pm 2) * 10^{-11}$
special relativity $\zeta_1 - \zeta_0 - 1$ (search for a preferred frame within special relativity)	$(-5 \pm 12) * 10^{-5}$
influence of dark matter δg_c [cm/s^2] (assumed in the center of the galaxy; test of strong equivalence principle)	$(4 \pm 4) * 10^{-14}$
preferred frame effect α_1 (search for a preferred frame within general relativity)	$(-8 \pm 9) * 10^{-5}$
preferred frame effect α_2	$(-1.2 \pm 2.5) * 10^{-5}$

Table 7.2.2.2-1: Relativistic parameters and their realistic errors.

A further activity of the last year was a test whether the annual geocenter motion can be determined from the analysis of LLR data. We obtained good results, comparable to those of other techniques as given in *IERS Technical Note 25* [1999], whereas we did not achieve as good an agreement with the theoretical values as did SLR. We did obtain an improvement in the accuracy of the equivalence princi-

ple parameter η which was expected by Ken Nordtvedt [*private communication*, 1999], because there is a projection of the annual signal into the synodic one.

We performed a test where we fixed $GM_{\text{Earth+Moon}}$ taking GM_{Earth} from a current SLR solution. We obtained encouraging results, but these investigations are still under way. It is also a question of general strategy whether one should fix as many or as few parameters as possible.

To simplify the identification of the real lunar returns from the raw noisy measurements as obtained in Wettzell, we have started to use variable intervals in the histogram representation which can additionally be shifted by the half of the bin's width. This work is still ongoing.

KEY POINTS OF CONTACT

The FESG is the owner of the software, however, most of the analyses are performed by Jürgen Müller (Institute for Astronomical and Physical Geodesy, Technical University Munich) who is also member of the ILRS/AWG. The death of Burkard Reichhoff, who had coded the LLR software completely in C⁺⁺, was a harsh blow for the FESG activities. Furthermore the leadership of FESG changed in September 1999. Markus Rothacher, member of the IGS Governing Board, succeeded Manfred Schneider. Our LLR team is completed by Ulrich Schreiber, who struggles to get LLR returns in Wettzell, and Dieter Egger, who takes care of the lunar predictions and is a specialist on computer and software related topics.

In our work we orient ourselves at the recommendation of the ILRS/AWG and the IERS Conventions. Concerning relativistic topics, we have good cooperation with Ken Nordtvedt, David Vokrouhlicky (Univ. Prague) and Michael Soffel (Univ. Dresden). Concerning principle questions of LLR analysis, there is a good (e-mail) contact between all Lunar Analysis Centers and with the staff at the observatories. For example, the Grasse LLR Observatory changed its strategy for calculating the errors of the normal points in January 1999, and circulated this information well before that date so users could be prepared.

FUTURE PLANS

Our LLR plans comprise all activities from the investigation of the raw lunar observations to the computation of realistic errors of the estimated LLR parameters.

As mentioned above, we started to improve our software for the detection of the real lunar returns from the raw observations which are very noisy. We want to use the semi-train structure for separating the noise and the real measurements (two students are working on this topic). If we are successful we want to standardize and automate the computation of the normal points.

We are also trying to automate the procedure for the generation of the standard solution which is used for the ITRF and IERS annual submissions. These are the steps described in the 'Background' section. In this respect, we have to take care to ensure the consistency of the LLR system and LLR products with those of the other space geodetic techniques. As a by-product, we have to improve our modeling, e.g., of the lunar gravity field, the lunar tidal acceleration with more periods or atmospheric loading and so on.

We will continue the relativistic investigations which are mainly driven by Ken Nordtvedt at the moment, in so far as new ideas to be tested are concerned.

We want to make sure that the potential of LLR is further acknowledged as an important tool not only for relativity tests, but also for the determination of many classical parameters.

In any case we should be prepared for a renaissance of lunar missions like the planned Japanese mission SELENE II, where transponders are deployed on the surface of the Moon which should enable many pure SLR stations to observe the Moon. Moreover, in the case of co-location of microwave transponders, the connection to the VLBI system may become possible which will open a wide range of further activities (e.g. frame ties).

Unfortunately at moment, we have received almost no financial support for LLR analysis. However, we have great motivation and enthusiasm (mainly produced by the potential of good results), and we have the software in-house. So let's do it!

REFERENCES

- Bauer R.: DGK C, No. 353, München 1989.
- Dickey J, Newhall X., Williams J.: JGR, Vol. 90, No. B11, P. 9353-9362, 1985.
- Gleixner H.: DGK C, No. 319, München 1986.
- IERS Standards (1989), IERS Technical Note 3, ed. by D. McCarthy, Paris 1989.
- IERS Standards (1992), IERS Technical Note 13, ed. by D. McCarthy, Paris 1992.
- IERS Conventions (1996), IERS Technical Note 21, ed. by D. McCarthy, Paris 1996.
- IERS Analysis Campaign to Investigate Motions of the Geocenter, IERS Technical Note 25, ed. by J. Ray, Paris 1999.
- Mathews P., Dehant V., Gipson J.: JGR, Vol. 102, No. B9, P. 20,469-20,477, 1997.
- Müller J.: DGK C, No. 383, München 1991.
- Müller J, Nordvedt K., Schneider M., Vokrouhlicky D.: BKG, Band 10, P. 216-222, 1999.
- Reichhoff B.: DGK C, No. 512, München 1999.

7.2.2.3 JET PROPULSION LABORATORY

Jim Williams and Jean Dickey, *Jet Propulsion Laboratory*

INTRODUCTION/BACKGROUND/DATA PRODUCTS PROVIDED

Analyses of laser ranges to the Moon are utilized for a broad range of investigations: lunar science, gravitational physics, geodesy, geodynamics and astronomy. Unique contributions from LLR include detection of a molten lunar core; measurement of tidal dissipation in the Moon; an accurate test of the principle of equivalence for massive bodies (strong equivalence principle); and detection of lunar free librations. LLR analysis has provided tests of relativity, measurements of the Moon's tidal acceleration and the Earth's precession, and has provided orders-of-magnitude improvements in the accuracies of the lunar ephemeris and three-dimensional rotation. JPL has been active in all of these various LLR applications and supplies lunar and planetary ephemerides and lunar physical librations to the community.

CURRENT ACTIVITIES

Our LLR analysis efforts have been focused on gravitational physics, including tests of general relativity, and studies of the lunar interior. Part of Abstract #2018 of the Lunar and Planetary Science Conference XXXI, March 2000 is given below; the reader is referred to LPSC Abstracts for the full text.

LUNAR POWER DISSIPATED BY TIDES AND CORE-MANTLE INTERACTION

J. G. Williams, D. H. Boggs, J. T. Ratcliff, C. F. Yoder and J. O. Dickey
Jet Propulsion Laboratory, California Institute of Technology, Pasadena, CA,
91109 (e-mail James.Williams@jpl.nasa.gov)

Introduction: Geophysical properties of the lunar interior are required to compute the dynamical contribution to the moon's heating. The heating is connected to development of solid convection in the mantle, fluid convection in the core, and generation of a lunar magnetic field.

Analysis of Lunar Laser Ranging data provides one opportunity to determine the moon's geophysical properties. Many lunar parameters, including bulk elastic and rotational dissipation parameters, are detected through their influence on lunar rotation. The Lunar Laser Ranging effort is reviewed in¹.

Dissipation Analysis: The present day 3.82 ± 0.07 cm/yr expansion of the lunar orbit¹ is dominated by tidal dissipation on the earth, but is slightly affected (~1%) by dissipation in the moon. Dissipation effects in the moon are detectable through their influence on lunar rotation. Hence, sources of dissipation in the earth and moon are separable.

A study of dissipation signatures in the lunar rotation finds two sources of dissipation in the moon: solid-body tides and a molten-core/solid-mantle interaction^{2, 3}. Tidal Q vs. frequency is determined; at 1 month the tidal Q is 37 and at 1 yr it is 60. The liquid core detection exceeds three times its uncertainty. The spin of the core is not aligned with the spin of the mantle and torque and energy dissipation arises from the velocity difference at the boundary. Yoder's turbulent boundary layer theory^{4, 5} is used to compute the core radius. The core radius is equal to less than 352 km for molten iron and is equal to less than 374 km for the Fe-FeS eutectic. Independent evidence for a (solid or liquid) core is presented in⁶.

REFERENCES

- ¹ Dickey et al. (1994) Science, 265, 482-490.
- ² Williams J G et al. (1999) Abstracts of Lunar and Planetary Science Conference XXX, Abstract No. 1984.
- ³ Williams J G et al. (2000) in preparation.
- ⁴ Yoder C. F. (1981) Phil. Trans. R. Soc. London A, 303, 327-338.
- ⁵ Yoder C. F. (1995) Icarus, 117, 250-286.
- ⁶ Konopliv A. S. et al. (1998) Science, 281, 1476-1480.

RECENT ABSTRACTS

Williams, J. G., D. H. Boggs, C. F. Yoder, J. T. Ratcliff and J. O. Dickey, Lunar Dissipation in Solid Body and Fluid Core, Eos Transactions of the Amer. Geophys. Union 79, F546, 1998.

Williams, J. G., D. H. Boggs, J. T. Ratcliff, and J. O. Dickey, The Moon's Molten Core and Tidal Q, Abstracts of the Lunar and Planetary Science Conference XXX, abstract #1984, 1999.

J. G. Williams, D. H. Boggs, J. T. Ratcliff, C. F. Yoder and J. O. Dickey, A View of the Lunar Interior Through Lunar Laser Ranging, abstract for New Views of the Moon II, Flagstaff, Sept 22-24, 1999.

J. G. Williams, P. J. Shelus, D. H. Boggs, J. O. Dickey, J. T. Ratcliff, and J. G. Ries, The Multidisciplinary Lunar Laser Ranging Experiment, abstract for Fall AGU Meeting, December 13-19, 1999.

J. G. Williams, D. H. Boggs, J. T. Ratcliff, C. F. Yoder and J. O. Dickey, Lunar Power Dissipated by Tides and Core-Mantle Interaction, Abstracts of the Lunar and Planetary Science Conference XXXI, abstract #2018, March 13-17, 2000.

KEY POINTS OF CONTACT

Name	Email	Telephone No.
James G. Williams	James.G.Williams@jpl.nasa.gov	(818) 354-6466
Dale H. Boggs	Dale.H.Boggs@jpl.nasa.gov	(818) 354-1630
Jean O. Dickey	Jean.O.Dickey@jpl.nasa.gov	(818) 354-3235
J. Todd Ratcliff	James.T.Ratcliff@jpl.nasa.gov	(818) 354-0204

All Key Points of Contact can be reached at:

Jet Propulsion Laboratory
Mail Stop 238-332
4800 Oak Grove Drive
Pasadena, CA 91109-8099
FAX: (818) 393-6890

FUTURE PLANS:

Investigation of lunar science and relativity utilizing LLR data; LLR analysis and lunar ephemeris and libration development.

ACKNOWLEDGMENT:

This paper presents the results of one phase of research carried out at the Jet Propulsion Laboratory, California Institute of Technology, under contract with the National Aeronautics and Space Administration.

7.2.2.4 UNIVERSITY OF TEXAS

Judit Ries, *University of Texas*

INTRODUCTION

The University of Texas McDonald Observatory Lunar Analysis Center (UTXM) is operating within the Department of Astronomy of the University of Texas at Austin, in conjunction with the McDonald Laser Ranging Station (MLRS) near Ft. Davis Texas. The Center has been providing weekly/monthly Earth

Orientation Parameters (EOP) since 1989 and also provides predictions for lunar data acquisition. It also acts as data quality controller for MLRS. Our goals are to develop a technique to improve the quality of marginal LLR data and to improve the quality of our EOP series.

BACKGROUND

The LLR team in Texas has been involved with the acquisition and the analysis of LLR data since the birth of the technique. Before on site normal point production became a routine, the Austin team filtered the data and created and distributed the normal points. It was a natural step to start to use this data and produce an EOP series.

FACILITIES

The EOP series and the lunar orbits are computed on a Sun workstation using a UNIX operating system, at the Department of Astronomy, using. The main software is the MIT Planetary Ephemeris Program (PEP) for the integration of the lunar orbit and for parameter estimation. The Lunar data is provided by the MLRS crew through the Internet, and we directly receive OCA LLR data by e-mail, courtesy of the French LLR station at Grasse.

CURRENT ACTIVITIES

Laser ranging is the measurement of the round-trip travel time of a photon, which is emitted from an Earth-based laser and reflected from one of the corner cubes placed on the lunar surface. Travel times at MLRS can be measured to 50-psec resolution. Changes in travel the times, that is changes in the separation between the transmitter and the reflector, contain a great deal of information about the Earth-Moon system that can be retrieved by estimating model parameters.

The analysis process

Lunar normal points are available to analysts since September 1969. They were obtained by the McDonald Observatory 2.7m telescope (which ceased operation in 1985), the McDonald Laser Ranging Station (saddle site and Mt. Fowlkes site) near Fort Davis, Texas, the Haleakala Observatory on Maui, Hawaii (which ceased operation in 1990) and the Observatoire de Cote d'Azur station in Grasse, France. We include all this data in our analysis. There are also a few normal points from Wettzell (Germany) but due to the limited quantity, it is included only with zero weight. We estimate various global parameters for the whole span of the lunar data. However, after these adjustments, the nightly residuals still show some signature. Assuming this is due to UT1R error in the *a priori*, we estimate nightly UT0 and Variation of Latitude ($\Delta\phi$) corrections. (For our weekly/monthly EOP series we convert this into UT1, X and Y values, using the *a priori* polar motion values.)

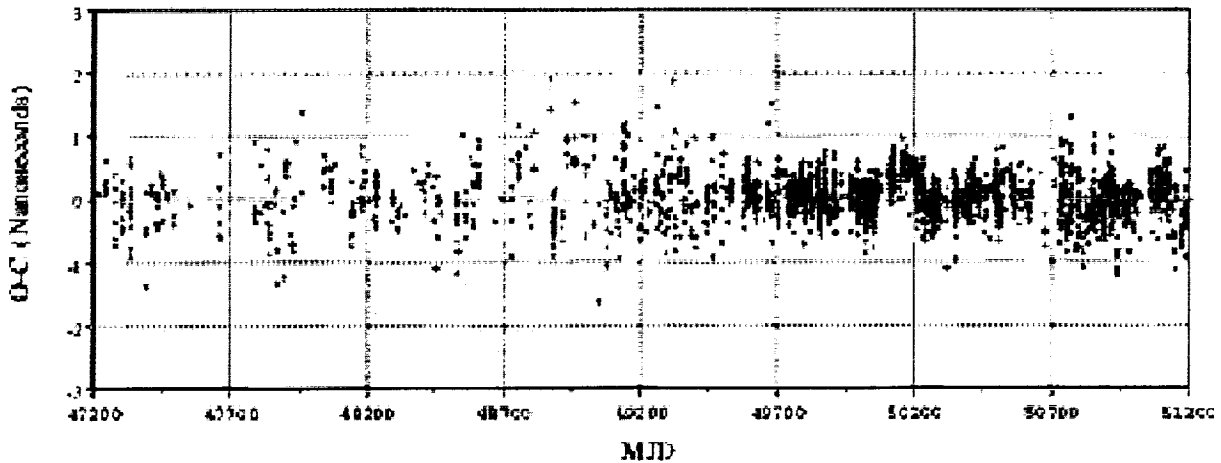

Figure 7.2.2.4-1. 2403 MLRS residuals (from all retro-reflectors) from February 1988 to December 1999

Our lunar orbit is based on the nbody740.2020 solar system ephemeris, provided by J. Chandler (CFA, Precision Astrometry Group). Using the LLR data, we adjust a number of global parameters. These include the GM of the Earth-Moon system, the orbit of the Moon, the EMbary orbit (with the exception of the node), lunar libration parameters, and third order gravitational coefficients of the Moon. The reflector and the station coordinates are also estimated with range biases for all the stations. The nutation amplitudes and the precession constant are also adjusted. Furthermore, we estimate a piecewise continuous linear spline for UT1R to model long period deficiencies in the *a priori* time series. The data is weighted according to the normal point uncertainty. The station assigned uncertainties are scaled by PEP. The resulting fit of the data from the Mt. Fowlkes site is shown on Figure 7.2.2.4-1. The mean of the data is 1.7×10^{-2} nsec with 0.37 nsec RMS about the mean. The nightly signature is due to UT1R error in the smoothed *a priori* series we use, which is a combination of early optical series and the modern LAGEOS based EOP series, provided by the Center for Space Research at UT. For nights with sufficient data we can remove this signal. The new mean is -2.8×10^{-3} , and the RMS is 0.28 nsec, illustrated on Figure 7.2.2.4-2. This corresponds to about 4.2 cm accuracy for the one way range.

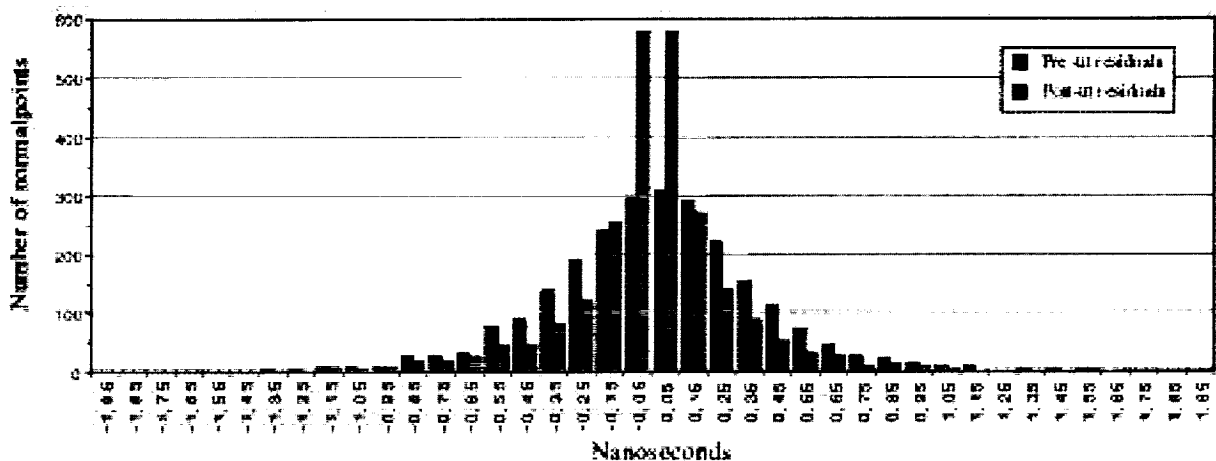

Figure 7.2.2.4-2 The distribution of the pre- and post UT0-UTC determination of MLRS residuals

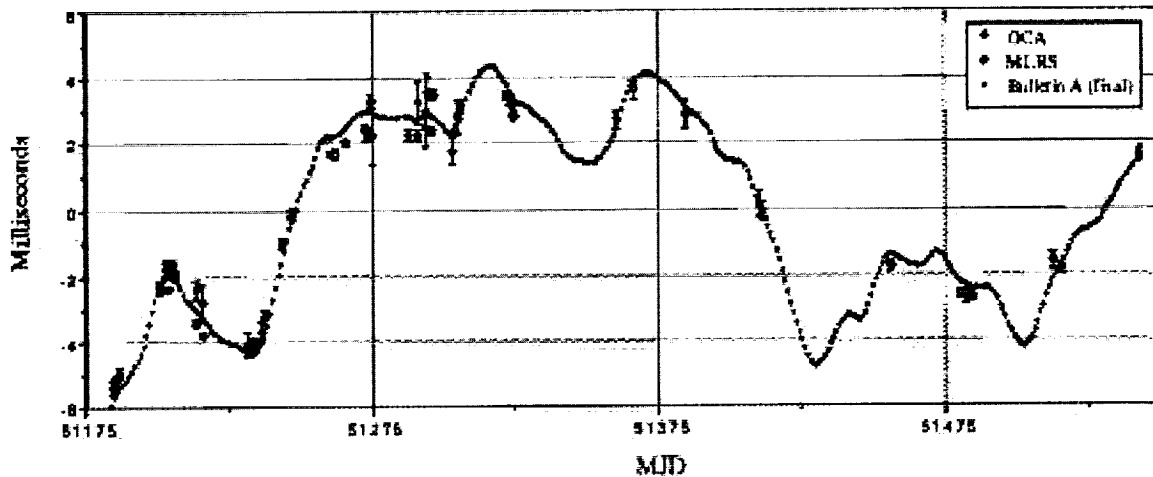

Figure 7.2.2.4-3. UT2-TAI with -1.013 msec/day slope removed (January 1 - December 31, 1999)

We provided a total of 54 UT0 -UTC values in 1999, 27 from OCA and 27 from MLRS reflector 3 (Hadley, Apollo 15), data. Only nights with at least 3 normal points and at least 1.5 hours span were accepted, and UT0 - UTC and $\Delta\phi$ were calculated using an iterative least square analysis. Figure 7.2.2.4-3 demonstrates the stochastic changes in the Earth rotation compared to a uniform time standard. It also compares our results with IERS Bulletin A EOP series. The actual products of our analysis are UT0 - UTC and $\Delta\phi$, which need to be converted using:

$$\text{UT0} - \text{UTC} = \text{UT1} - \text{UTC} + (X \sin\lambda + Y \cos\lambda) \tan\phi/15$$

$$\Delta\phi = X \cos\lambda - Y \sin\lambda$$

and

$$\text{UT2} - \text{UT1} = 0.022 \sin(2\pi T) - 0.012 \cos(2\pi T) - 0.006 \sin(4\pi T) + 0.007 \cos(4\pi T)$$

$$T = 2000.000 + (\text{MJD} - 51544.03)/365.2422 \text{ (Besselian years)}$$

The corresponding units are seconds for UT0 - UTC, seconds of arc for X and Y, λ and $\Delta\phi$ are the station's East longitude and geodetic latitude.

RELATED PUBLICATIONS

Aoki, S., Guinot, G. H., Kaplan, H., Kinoshita, D. D., McCarthy, and P. K. Seidelmann, (1982). "The New Definition of Universal Time", *Astron. Astrophys.* 105, 359-361.

Eanes, R. J. and M. M. Watkins, CSR95L01 Solution, The 1994 IERS Annual Report, Observatoire de Paris, France, 1995.

Explanatory Supplement to IERS Bulletins A and B, March 1999

Jefferys, W. H. and J. Györgyey Ries, Bayesian analysis of lunar laser data, in *Statistical Challenges in Modern Astronomy II*, G. J. Babu and E. D. Feigelson (eds), 49-62, Springer Verlag, 1997.

Ricklefs, R. L. and P.J. Shelus, Poisson filtering of laser ranging data, in *Proceeding of the Eighth International Workshop on Laser Ranging Instrumentation*. Annapolis: NASA conference Publication 3214, 1992.

Stolz, A., P. L. Bender, J. E. Faller, E. C. Silverberg, J. D. Mulholland, P. J. Shelus, J. G. Williamson, W. E. Carter, D. G. Currie and W. M. Kaula, Earth rotation measured by lunar laser ranging, *Science*, 193, 997-999, 1976

UT0 and Variation of Latitude Determination from Lunar Laser Ranging Observations for 1969-1998, Ries, J. Györgyey, R. L. Ricklefs, P. J. Shelus, J. R. Wiant, 1998 IERS Annual Report, Observatoire de Paris, France, 1999.

KEY POINTS OF CONTACT

Author: Judit Györgyey Ries

Address: The University of Texas at Austin, Austin, TX 78712, USA

Contact: moon@astro.as.utexas.edu

FUTURE PLANS

We will continue to provide monthly and annual EOP series to the community, while improving the quality and the stability of our solution. We have shown with simulated lunar data that we can recover data considered marginal with the application of Bayesian statistics. We hope to work on applying this method to real data.

SECTION 8

ILRS INFORMATION



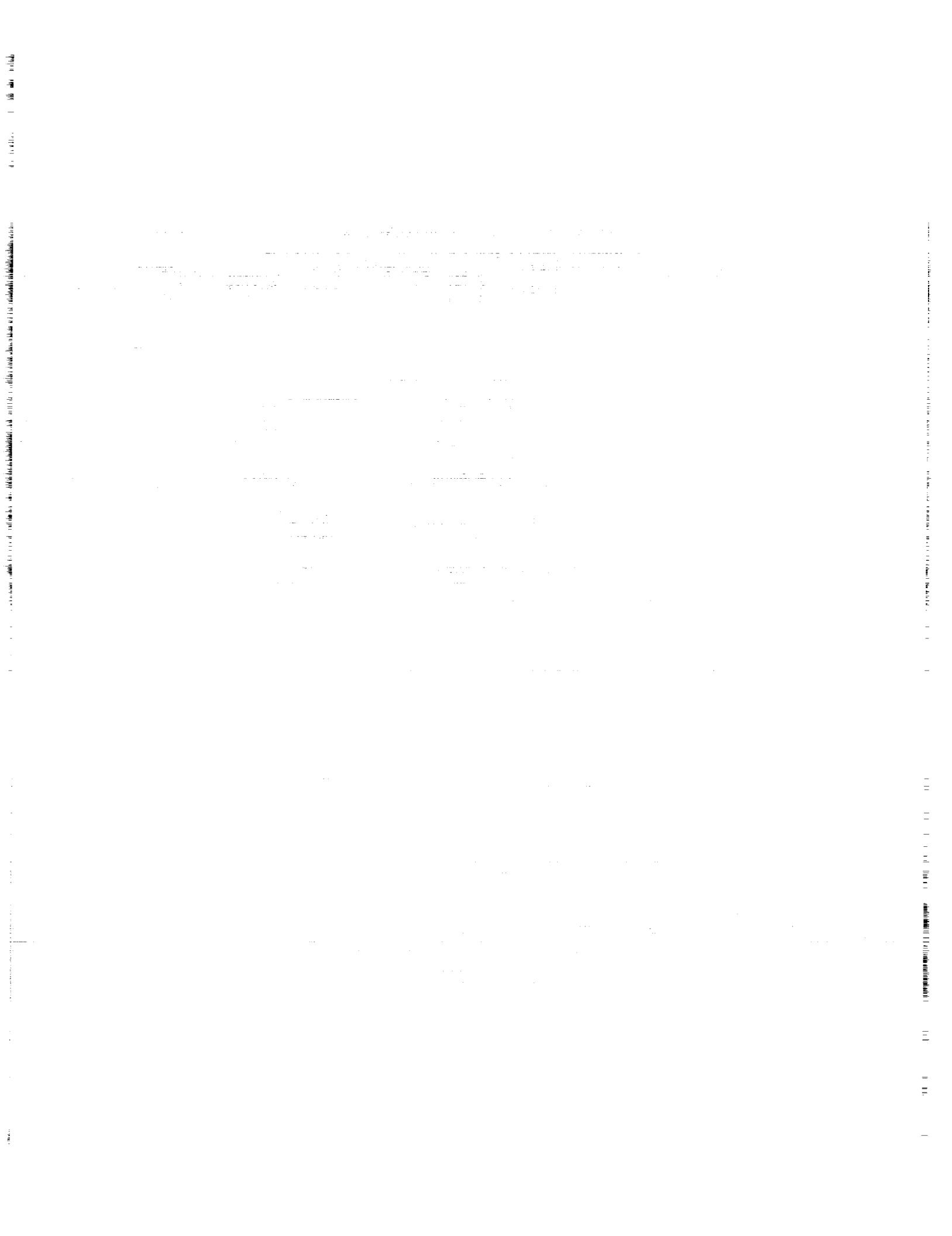

SECTION 8 - ILRS INFORMATION

Van Husson, *Honeywell Technology Solutions, Inc.*
Carey Noll, *Crustal Dynamics Data Information System*

8.1 ILRS TERMS OF REFERENCE

INTRODUCTION

Charter and Affiliations

The International Laser Ranging Service (ILRS) is an established Service within Section II, Advanced Space Technology, of the International Association of Geodesy (IAG). The primary objective of the ILRS is to provide a service to support, through Satellite and Lunar Laser Ranging data and related products, geodetic and geophysical research activities as well as International Earth Rotation Service (IERS) products important to the maintenance of an accurate International Terrestrial Reference Frame (ITRF). The service also develops the necessary standards/specifications and encourages international adherence to its conventions.

Services

The ILRS collects, merges, archives and distributes Satellite Laser Ranging (SLR) and Lunar Laser Ranging (LLR) observation datasets of sufficient accuracy to satisfy the objectives of a wide range of scientific, engineering, and operational applications and experimentation. These data sets are used by the ILRS to generate a number of scientific and operational data products including but not limited to:

- Earth orientation parameters (polar motion and length of day)
- Three-dimensional coordinates and velocities of the ILRS tracking stations
- Time-varying geocenter coordinates
- Static and time-varying coefficients of the Earth's gravity field
- Centimeter accuracy satellite ephemerides
- Fundamental physical constants
- Lunar ephemerides and librations
- Lunar orientation parameters

The accuracy of SLR/LLR data products is sufficient to support a variety of scientific and operational applications including:

- Realization of global accessibility to and the improvement of the International Terrestrial Reference Frame (ITRF)

- Monitoring three-dimensional deformations of the solid Earth
- Monitoring Earth rotation and polar motion
- Support the monitoring of variations in the topography and volume of the liquid Earth (ocean circulation, mean sea level, ice sheet thickness, wave heights, etc.)
- Tidally generated variations in atmospheric mass distribution
- Calibration of microwave tracking techniques
- Picosecond global time transfer experiments
- Astrometric observations including determination of the dynamic equinox, obliquity of the ecliptic, and the precession constant
- Gravitational and general relativistic studies including Einstein's Equivalence
- Principle, the Robertson-Walker b parameter, and time rate of change of the gravitational constant, G
- Lunar physics including the dissipation of rotational energy, shape of the core-mantle boundary (Love Number k_2), and free librations and stimulating mechanisms
- Solar System ties to the International Celestial Reference Frame (ICRF)

Amendments to the ILRS Terms of Reference

A proposal to amend the ILRS Terms of Reference can be made in writing to the Chairperson of the Governing Board (see "*GOVERNING BOARD*") by any ILRS Associate Member (see "*ILRS Associate Members*"). Proposed amendments will be forwarded by e-mail to all ILRS Associate Members of record for comment and amended as necessary by the Chairperson prior to a Governing Board vote. Associate Members will be given two weeks to comment. Final approval of any such amendment requires a 2/3 affirmative vote of the Governing Board. Proposed amendments to the Terms and subsequent Board actions will be summarized and presented to the Associate Members by the Chairperson at the next General Assembly.

PERMANENT COMPONENTS OF THE ILRS

The ILRS accomplishes its mission through the following permanent components:

- Tracking Stations and Subnetworks
- Operations Centers
- Global and Regional Data Centers
- Analysis, Lunar Analysis, and Associate Analysis Centers
- Central Bureau

The characteristics and responsibilities of these entities is described in the following subsections.

Tracking Stations and Subnetworks

ILRS Tracking Stations range to a constellation of approved satellites (including the Moon), contained in a list of satellites compiled and approved by the ILRS Governing Board, through the use of state of the art laser tracking equipment and data transmission facilities which allow for a rapid (at least daily) data transmission to one or more Operations and/or Data Centers (see below).

The stations must meet data accuracy, quantity, and timeliness requirements which are specified in separate documents. The tracking data produced by the ILRS stations are regularly and continuously analyzed by at least one ILRS Analysis Center or one mission-specific Associate Analysis Center.

Tracking Stations may be organized into regional or institutional subnetworks.

Operations Centers

The Operational Centers are in direct contact with tracking sites organized in a subnetwork. Their tasks include the collection and merging of data from the subnetwork, initial data quality checks, data reformatting into a uniform format, compression of data files if requested, maintenance of a local archive of the tracking data, and the electronic transmission of data to a designated ILRS Data Center. Operational Centers also provide the tracking sites with sustaining engineering, communications links, and other technical support. In addition, Operational Centers can perform limited services for the entire network.

Individual tracking stations can also perform part or all of the tasks of an Operational Center themselves.

Data Centers

Regional Data Centers

The Regional Data Centers reduce traffic on electronic networks. They collect reformatted tracking data from Operational Data Centers and/or individual tracking stations, maintain a local archive of the data received and, in some cases, transmit these data to the Global Data Centers. Regional Data Centers may also meet the requirements for Operational Centers and Global Data Centers (as defined in the previous and following paragraphs) of strictly regional network operations and duplicate activities of Global Data Centers to facilitate easy access to the information and products.

Global Data Centers

The Global Data Centers are the primary interfaces to the Analysis Centers and the outside user community. Their primary tasks include the following:

- Receive/retrieve, archive and provide on-line access to tracking data received from the Operational/Regional Data Centers
- Provide on-line access to ancillary information such as site information, occupation histories, meteorological data, site specific engineering data, etc.

- Receive/retrieve, archive and provide on-line access to ILRS scientific data products received from the Analysis Centers
- Backup and secure ILRS data and products

Analysis Centers

The analysis centers fall into three categories: Analysis Centers, Lunar Analysis Centers, and Associate Analysis Centers.

Analysis Centers

The Analysis Centers receive and process tracking data from one or more data centers for the purpose of producing ILRS products. The Analysis Centers are committed to produce the products, without interruption, at an interval and with a time lag specified by the Governing Board to meet ILRS requirements. The products are delivered to the Global Data Centers, to the IERS (as per bilateral agreements), and to other bodies, using designated standards. At a minimum, the Analysis Centers must process the global LAGEOS-1 and LAGEOS-2 data sets and are encouraged to include other geodetic satellites in their solutions.

The Analysis Centers provide, as a minimum, Earth orientation parameters on a weekly or sub-weekly basis, as well as other products, such as station coordinates, on a monthly or quarterly basis or as otherwise required by the IERS. The Analysis Centers also provide a second level of quality assurance on the global data set by monitoring individual station range and time biases via the fitted orbits (primarily the LAGEOS 1 and 2 satellites) used in generating the quick-look science results.

Associate Analysis Centers

Associate Analysis Centers are organizations that produce special products, such as satellite predictions, time bias information, precise orbits for special-purpose satellites, station coordinates and velocities within a certain geographic region, or scientific data products of a mission-specific nature. Associate Analysis Centers are encouraged to perform additional quality control functions through the direct comparison on individual Analysis Center products and/or the creation of “combined” solutions, perhaps in combination with data from other space geodetic techniques (e.g. VLBI, GPS, GLONASS, DORIS, PRARE, etc.), in support of the IERS International Terrestrial Reference Frame (ITRF) or precise orbit determination. Organizations with the desire of eventually becoming Analysis Centers may also be designated as Associate Analysis Centers by the Governing Board until they are ready for full scale operation.

Lunar Analysis Centers

Lunar Analysis Centers process normal point data from the Lunar Laser Ranging (LLR) stations and generate a variety of scientific products including precise lunar ephemerides, librations, and orientation parameters which provide insights into the composition and internal makeup of the Moon, its interaction with the Earth, tests of General Relativity, and Solar System ties to the International Celestial Reference Frame.

Central Bureau

The Central Bureau (CB) is responsible for the daily coordination and management of the ILRS in a manner consistent with the directives and policies established by the Governing Board. The primary functions of the CB are to facilitate communications and information transfer within the ILRS and between the ILRS and the external scientific community, coordinate ILRS activities, maintain a list of satellites approved for tracking support and their priorities, promote compliance to ILRS network standards, monitor network operations and quality assurance of data, maintain ILRS documentation and databases, produce reports as required, and organize meetings and workshops.

Although the Chairperson of the Governing Board is the official representative of the ILRS to external organizations, the CB, consonant with the directives established by the Governing Board, is responsible for the day-to-day liaison with such organizations.

The CB coordinates and publishes all documents required for the satisfactory planning and operation of the Service, including standards/specifications regarding the performance, functionality and configuration requirements of all elements of the Service including user interface functions.

The CB operates the communication center for the ILRS. It produces and/or maintains a hierarchy of documents and reports, in both hard copy and electronic form, including network information, standards, newsletters, electronic bulletin board, directories, summaries of ILRS performance and products, and an Annual Report.

The Central Bureau may propose to the Governing Board names of individuals to be elected as members at large to help ensure the proper representation of important contributing organizations.

The responsibilities and activities of the Central Bureau may be distributed between different groups and organizations according to written agreements and charters.

In summary, the Central Bureau performs a long term coordination and communication role to ensure that ILRS participants contribute to the Service in a consistent and continuous manner and that they adhere to ILRS standards.

The Central Bureau is headed by a Central Bureau Director, who is an ex-officio member of the ILRS Governing Board. The Secretary of the GB is also provided by the Central Bureau.

GOVERNING BOARD

Roles and Responsibilities

The Governing Board is responsible for the general directions in which the ILRS is providing its services. It defines the official ILRS products, decides upon the satellites to be included in the ILRS tracking list, accepts standards and procedures prepared and proposed by the individual bodies of the ILRS and ensures, through its chairperson, the contact to other services and organizations.

The GB exercises general control over the activities of the Service including modifications to the organization that would be appropriate to maintain efficiency and reliability, while taking full advantage of the advances in technology and theory.

Most GB decisions are to be made by consensus or by a simple majority vote of the members present, provided that there is a quorum consisting of at least ten members of the GB. In case of lack of a quorum

the voting is by mail or e-mail. Changes in Terms of References and the Chairperson of the GB can be made by a 2/3 majority of the members of the GB, i.e., by twelve or more votes.

Membership

The Governing Board consists of both appointed and elected members. The appointed members include:

- Director of the Central Bureau 1
- Secretary of the Central Bureau 1
- President of IAG Sect. II or Com. VIII (CSTG) 1

Members elected by their peers within the ILRS Associates include:

- NASA SLR Network representatives 2
- EUROLAS Network representatives 2
- WPLTN Network representatives 2
- Analysis and Associate Analysis Centers' representatives 2
- Data centers' representative 1
- LLR Representative 1
- At-Large Members 2
- IERS Representative 1

Total 16

The appointed members are considered ex-officio and are not subject to institutional restrictions. The elected board positions are nominated by the ILRS components they represent for a two-year term. The At-Large members are intended to compensate for under-representation among the various components of the ILRS or to provide additional skills or knowledge of use to the Board in carrying out its duties. The total GB membership should be properly balanced in all respects with regard to supporting organizations, skill mix, geography, etc.

Nomination and Election of Members

ILRS Associate Members (see “*ILRS Associate Members*”), together with the GB, may nominate and vote for the elected members of the GB. The Call for Nominations and GB Elections will be conducted by the Central Bureau via official e-mail lists and will be held approximately every two years prior to the International Workshop on Laser Ranging. Newly elected GB members will be installed at the next semiannual meeting. With the exception of At-Large members, GB nominees must be associated with the relevant ILRS component (e.g. Analysis, Data Centers, Lunar, etc.), and only ILRS Associate Members officially associated with that component as determined by the official e-mail lists maintained by the CB can participate in the election of their representative. The full ILRS membership can vote for At-Large members. The GB will be final arbiter on an individual’s qualifications for a particular elected post on the Board. Election is by a simple majority of votes received. In the unlikely event of a tie vote, the GB will make the final selection in Executive Session.

Election and Role of Chairperson

The GB Chairperson is elected by the Board from among its members for a term of two years, renewable for three terms. Nomination and selection of the Chairperson is carried out in GB Executive Session during the biannual Workshop Meeting. The Chairperson does not vote, except in case of a tie. He/she is the official representative of the ILRS to external organizations.

Frequency of Meetings

The Board shall endeavor to meet semiannually and at such other times as shall be considered appropriate or opportune by the Chairperson or at the request of at least eight members.

Rights and Privileges of GB Members

Members of the GB shall become IAG Fellows with the appropriate rights and privileges following two years of recognized service.

Analysis and Lunar Coordinators

The laser ranging technique is a broad based one. As an observational technique, the division between lunar laser ranging and artificial satellite laser ranging has become largely a historical one. However, present differences in many areas related to observations (e.g., predictions and data formats) are still being reconciled. It must also be recognized that the major data analysis packages that are presently used for artificial satellite analysis are not yet equipped to deal with lunar laser ranging observations and most of the LLR analysis packages are equally not yet compatible with SLR observations. Thus, it is prudent to maintain separate LLR and SLR coordinators for an, as yet, undefined time into the future. The SLR and LLR coordinators must work within their own disciplines to maintain observational and data integrities. However, they must also work together in an effort to unify both techniques, bringing together the best of both, and, when possible, learning from the other.

The Analysis Coordinator is a voting member of the ILRS Governing Board and is elected by the Governing Board as the ILRS representative to the IERS Directing Board. Under a reciprocal arrangement, the IERS designates a representative to serve as a voting member on the ILRS Governing Board. The Lunar Coordinator may represent the ILRS as a deputy voting member on the IERS Directing Board in the Analysis Coordinator's absence and may otherwise attend IERS Board meetings at their discretion in a non-voting advisory capacity.

The Analysis Coordinator chairs the Analysis Working Group which includes, at a minimum, the Lunar Coordinator, one representative from each of the Global Analysis Centers and may contain representatives of Associate Analysis Centers as well.

The responsibility of the Analysis Coordinator is to monitor the Analysis Centers' activities to ensure that the ILRS objectives are carried out. Specific expectations include global data quality control, station performance evaluation and reporting, and continued development of appropriate analysis standards and formats for the final science products. The Analysis Coordinator is also responsible for the appropriate combination of designated Analysis Centers products into a single and coherent set of products.

The Analysis Coordinator ensures that the ILRS products produced by the ILRS Analysis and Associate Analysis Centers conform with IERS requirements and standards.

Working Groups

The Governing Board, at its discretion, can create or disband Working Groups. A Working Group (WG) may be either permanent (Standing) or temporary (Ad-Hoc) in nature. Standing Working Groups are created by the GB to carry out continuously evolving business of the ILRS. Occasionally, Ad-Hoc Working Groups are appointed to carry out special investigations or tasks of a temporary or interdisciplinary nature.

The Coordinator of each Standing WG is selected by the GB from amongst its members to ensure close coupling of the WG with the GB and its goals. The WG Coordinator can independently appoint additional members to the WG from among the other GB members, ILRS Associate Members or ILRS Correspondents (see below). The WG Coordinator may also designate a Deputy to act on his/her behalf in his/her absence. All GB members, with the exception of the ex-officio members, Chairperson, and IERS representative to the ILRS are required to serve on at least one of the Standing Working Groups.

The Coordinator for Ad-Hoc Working Groups may be chosen, at the discretion of the Board, from outside its membership in order to best fulfill the goals of that WG.

Currently, the Standing Working Groups are:

- Missions
- Data Formats and Procedures
- Networks and Engineering
- Analysis

DEFINITIONS

ILRS Associate Members

Persons affiliated with recognized ILRS institutions and who routinely participate in any of the ILRS activities (management, missions, tracking, engineering, operations, data analysis, archiving, etc.) are eligible to be ILRS Associate Members. To gain official membership in the ILRS, the ILRS institution must submit the person's name, e-mail, and primary ILRS function in the organization. ILRS Associate Members do not have to be employed by their institution sponsor; they merely need to provide a recognized ILRS-related service to the sponsoring institution under a contractual or cooperative arrangement. The Associate's stated function will determine eligibility to nominate and/or vote for specific GB representatives as described in "*Nomination and Election of Members.*"

Associate Members may attend open (non-executive) ILRS meetings which are announced to the general community by the CB, place nominations for elected GB posts, vote in ILRS elections, and serve on the Governing Board if appointed or elected. A directory, electronic and/or hard copy, of ILRS Associate Members, and their approved association with a particular component of the ILRS, is maintained by the CB.

ILRS Associate Members are considered IAG Affiliates with the corresponding rights and privileges.

ILRS Correspondents

ILRS Correspondents are persons on a mailing list maintained by the Central Bureau, who do not actively participate in the ILRS but who either express interest in receiving ILRS publications, wish to participate in workshops or scientific meetings organized by the ILRS, or generally are interested in ILRS activities. Ex-officio ILRS Correspondents are the following persons:

- IAG General Secretary
- President of IAG Section V

8.2 ILRS WEBSITE REFERENCE CARD

ILRS Data, Algorithms, and Formats

Daily Normal Point (NP) Data

Normal point algorithm:
http://ilrs.gsfc.nasa.gov/np_algo.html
 ILRS NP format overview:
http://ilrs.gsfc.nasa.gov/np_format_intro.html
 ILRS NP format (SLR & LLR)
http://ilrs.gsfc.nasa.gov/np_format.html
 NP data access (root directory):
<ftp://cdlisa.gsfc.nasa.gov/pub/ilrs/np/>
<ftp://ftp.dgfi.bodw-muenchen.de/pub/laser/qidub/>
 LLR NP data access (root directory):
<ftp://ftp.dgfi.bodw-muenchen.de/pub/laser/qldata/>
 Data centers NP file naming conventions:
 CDDIS - daily new (qlyymmdd.sstsbbl)
 CDDIS - monthly (new.qlyymm.sstsbbl)
 EDC - daily (aammmn.yymm.daa)
 EDC - monthly (sstname.yymm)

Daily SLR Full-Rate (FR) Data

ILRS FR format:
http://ilrs.gsfc.nasa.gov/fr_format_v2.html
 FR data access:
<ftp://cdlisa.gsfc.nasa.gov/pub/ilrs/fr/>
<ftp://ftp.dgfi.bodw-muenchen.de/pub/laser/fr/data/>

ILRS Analysis Information

International Terrestrial Reference Frame (ITRF):
<http://pioneers.obspm.fr/avobiers/gwvcal/tyframes/itrf.html>

SINEX format:

ftp://cdlisa.gsfc.nasa.gov/utw/formats/sinex1_format

ILRS Reports

ILRS Meeting Minutes:
http://ilrs.gsfc.nasa.gov/ilrs_reports.html

System Performance

Weekly/Daily Reports:
http://ilrs.gsfc.nasa.gov/mismission_analysis.html
 Quarterly Report Card:
<http://ilrs.gsfc.nasa.gov/quarterlyreportcard.html>

ILRS Station Information

ILRS Network

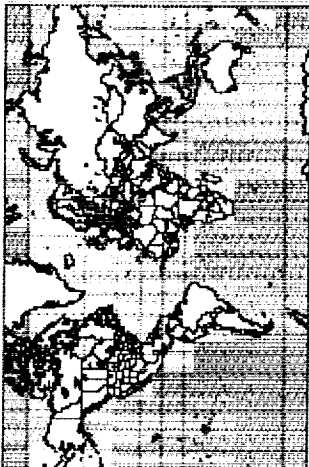

Stations:

<http://ilrs.gsfc.nasa.gov/stations.html>

Site Identifiers

DOMES procedure:
http://ilrs.gsfc.nasa.gov/ob/nas_and_domex.html

Site Occupation Designer (SOD) procedure:
<http://ilrs.gsfc.nasa.gov/sod.html>

SOD and DOMES numbers of current sites:
http://ilrs.gsfc.nasa.gov/sod_domex.html

ILRS System SODs:
<ftp://cdlisa.gsfc.nasa.gov/pub/sod/sod.html>

ILRS Site Coordinates:
<ftp://cdlisa.gsfc.nasa.gov/pub/ilrs/coords.html>

ILRS Site Eccentricities:
<ftp://cdlisa.gsfc.nasa.gov/pub/ilrs/coords.html>

Site Configuration reporting procedure:
http://ilrs.gsfc.nasa.gov/sys_config_proc.html

Configuration file(s) access:
<ftp://cdlisa.gsfc.nasa.gov/pub/reports/simcif/>
<ftp://ftp.dgfi.bodw-muenchen.de/pub/laser/station/>

Bias Information:
http://ilrs.gsfc.nasa.gov/slr_problems_index.html



ILRS Central Bureau
 NASA GSFC
 Code 920 T
 Greenbelt, MD 20771 USA

WWW: <http://ilrs.gsfc.nasa.gov>
 E-mail: cdlisa@ilrs.gsfc.nasa.gov
ilrs@ilrs.gsfc.nasa.gov
 Phone: +1 301-614 5488
 Fax: +1 301 614 5670



ILRS Quick Reference Card

<http://ilrs.gsfc.nasa.gov>

The ILRS is based on a global network of stations that provide data for the International Terrestrial Reference Frame (ITRF). The ILRS is a global network of stations that provide data for the International Terrestrial Reference Frame (ITRF). The ILRS is a global network of stations that provide data for the International Terrestrial Reference Frame (ITRF).

The ILRS is a global network of stations that provide data for the International Terrestrial Reference Frame (ITRF). The ILRS is a global network of stations that provide data for the International Terrestrial Reference Frame (ITRF). The ILRS is a global network of stations that provide data for the International Terrestrial Reference Frame (ITRF).

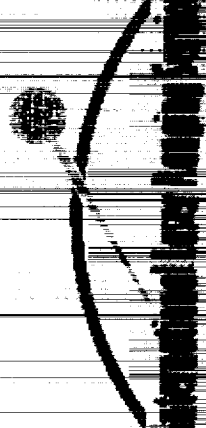

ILRS General Information

- ILRS Screen cc: <http://ilrs.gsfc.nasa.gov/screen.html>
- ILRS Bibliography: <http://ilrs.gsfc.nasa.gov/biblio.html>
- ILRS Meeting Schedule: <http://ilrs.gsfc.nasa.gov/meeting.html>
- ILRS Acronyms: <http://ilrs.gsfc.nasa.gov/acronyms.html>
- Terms of Reference: <http://ilrs.gsfc.nasa.gov/terms.html>
- SLR Overview: <http://ilrs.gsfc.nasa.gov/slrover.pdf>
- Governing Board: <http://ilrs.gsfc.nasa.gov/gb.html>
- Satellite Missions: <http://ilrs.gsfc.nasa.gov/missions.html>
- Stations: <http://ilrs.gsfc.nasa.gov/stations.html>
- Analysis Centers: http://ilrs.gsfc.nasa.gov/analysis_centers.html
- Working Groups: <http://ilrs.gsfc.nasa.gov/working.html>
- Central Bureau: <http://ilrs.gsfc.nasa.gov/central.html>
- Global Data Centers**
- WWW: <http://oddis.gsfc.nasa.gov/oddis.html>
<http://www.dgfi.baww.murcn.mn.de/oddis.html>
- Anonymous ftp access (root directory): <ftp://oddis.gsfc.nasa.gov/pub/ilr>
<ftp://ftp.dgfi.baww.murcn.mn.de/pub/ilr>

ILRS Working Groups (WG)

- WG Activities**
- Data Formats and Procedures (DF&P): http://ilrs.gsfc.nasa.gov/data_activities.html
- Rapid LEO Predictions: <http://ilrs.gsfc.nasa.gov/leo.html>
- Analysis: http://ilrs.gsfc.nasa.gov/analysis_activities.html
- Missions: http://ilrs.gsfc.nasa.gov/missions_activities.html
- Networks and Engineering (N&E): http://ilrs.gsfc.nasa.gov/networks_activities.html
- Center of Mass and Signal Processing (SP): http://ilrs.gsfc.nasa.gov/center_of_mass_activities.html

ILRS Directory and E-Mail

- ILRS personal directory: http://ilrs.gsfc.nasa.gov/ilrs_directory.html
- ILRS Email Explorers**
- Governing Board: ilrs@ilrs.gsfc.nasa.gov
- Central Bureau: cb@ilrs.gsfc.nasa.gov
- Stations: ilrsst@ilrs.gsfc.nasa.gov
- Analysis and Associated Analysis Centers: ilrsan@ilrs.gsfc.nasa.gov
- Data Centers: ilrsdc@ilrs.gsfc.nasa.gov
- ILRS Associates and Correspondents (SLRMail): ilrsall@dgfi.baww.murcn.mn.de
- SLRMail Procedure: <http://ilrs.gsfc.nasa.gov/slrm.html>
- Archive of SLRMail messages: <http://oddis.gsfc.nasa.gov/pub/reports/slrm.html>
<http://ftp.dgfi.baww.murcn.mn.de/pub/leasr/messages/slrm.html>
- Working Groups: ilrsd@ilrs.gsfc.nasa.gov
DF&P - ilrsd@ilrs.gsfc.nasa.gov
Analysis - ilrsan@ilrs.gsfc.nasa.gov
Missions - ilrsm@ilrs.gsfc.nasa.gov
N&E - ilrsnw@ilrs.gsfc.nasa.gov
SP - ilrsp@ilrs.gsfc.nasa.gov

WWW Links

- Mirror Sites: <http://ilrs.dgfi.baww.murcn.mn.de/oddis.html>
<http://www.dgfi.baww.murcn.mn.de/oddis.html>
<http://ilrs-home.html>
- Agencies: <http://ilrs.gsfc.nasa.gov/agencylinks.html>
- Analysis Centers: <http://ilrs.gsfc.nasa.gov/analysislinks.html>
- Satellite Missions: <http://ilrs.gsfc.nasa.gov/satellitelinks.html>
- Stations: <http://ilrs.gsfc.nasa.gov/stationlinks.html>

ILRS Mission Information

- Satellite Missions: <http://ilrs.gsfc.nasa.gov/missions.html>
- Satellite Tracking Priorities: <http://ilrs.gsfc.nasa.gov/priorities.html>
- Satellite IDs, Bin Sizes, Order Info: http://ilrs.gsfc.nasa.gov/satellite_ids.html
- Mission Support Request Form: <http://ilrs.gsfc.nasa.gov/msrform.html>
- Satellite Support History: http://ilrs.gsfc.nasa.gov/satellite_support.html
- Satellite Predictions (excluding Lunar) Transit IRV (TIRV) format: <http://oddis.gsfc.nasa.gov/pub/formats/irvformat.html>
- TIRV force model: <http://ilrs.gsfc.nasa.gov/tirv.html>
- TIRV access: <http://oddis.gsfc.nasa.gov/calb/predictor/>
<http://ftp.csc.utexas.edu/pub/ilr/irvformat/>
<http://ftp.dgfi.baww.murcn.mn.de/pub/ilr/irvformat/>
- Lunar Ephemeris: <http://ilrs.gsfc.nasa.gov/ephemeris.html>
- NORAD 2-line element format: <http://ftp.csc.utexas.edu/pub/ilr/irvformat/>
<http://ftp.dgfi.baww.murcn.mn.de/pub/ilr/irvformat/>
- NORAD 2-line element access: <http://oddis.gsfc.nasa.gov/ephemeris/index.html>
<http://ftp.csc.utexas.edu/pub/ilr/irvformat/>
- Maneuver format: <http://ilrs.gsfc.nasa.gov/maneuver.html>
- Maneuver History: <http://ilrs.gsfc.nasa.gov/maneuver.html>
- Drag function format: http://ilrs.gsfc.nasa.gov/drag_function.html
- Drag function algorithm: http://ilrs.gsfc.nasa.gov/drag_function_algorithm.html
- Time bias function (TBF) format: http://ilrs.gsfc.nasa.gov/tbf_function_format.html
- TBF data format: http://ilrs.gsfc.nasa.gov/tbf_format_intro.html
- TBF access: <http://oddis.gsfc.nasa.gov/priorreports/slrbif/>
<http://ftp.dgfi.baww.murcn.mn.de/pub/leasr/timebias/>
<http://ilrs-home.html>
- Prediction centers: http://ilrs.gsfc.nasa.gov/prediction_centers.html

8.3 ILRS WEBSITE MAP

The ILRS Home Page at NASA in the USA

<http://ilrs.gsfc.nasa.gov/>

is mirrored at EDC in Germany

http://www.dgfi.badw-muenchen.de/edc/ilrs/ilrs_home.html

and CRL in Japan

http://galileo.crl.go.jp/ilrs/ilrs_home.html

FAQs	Contact the ILRS	What's New
<ul style="list-style-type: none"> • 	<ul style="list-style-type: none"> • Directory of Associates • Associate Locator 	<ul style="list-style-type: none"> • Campaign/Missions News • Meetings News • Station News
Engineering/Technology	Data Products/Formats	Science/Analysis
<ul style="list-style-type: none"> • Collocation Results • Performance Evaluation • SLR Applications • SLR Animation 	<ul style="list-style-type: none"> • Normal Points (NP) • Predictions • Fullrate (FR) • Data Flow 	<ul style="list-style-type: none"> • IERS Conventions • Analysis Centers • Analysis Data Products • Mission Analysis Reports • ITRF Yearly Solutions • SLR and Earth Science • Science meetings
Satellite Missions	About the ILRS	Stations
<ul style="list-style-type: none"> • Campaign/Mission News • Campaign Reports • List of Missions • Mission Analysis Reports • Mission Parameters • Mission Support History • Priorities • Request Tracking Support 	<ul style="list-style-type: none"> • Acronyms • Call for Participation • Central Bureau • Governing Board • History • Join the ILRS • Meetings • Network Map • Organization Chart • Standards • Terms of reference 	<ul style="list-style-type: none"> • Configurations • Contacts • Coordinates • Data Anomalies • DOMES Procedure • Eccentricity Database • Network Map • News • Site Pressure Profiles • SOD and DOMES Numbers • SOD Procedure • Status Reporting • System Performance

Links	Reports	Working Groups (WG)
<ul style="list-style-type: none"> • Agencies • Altimetry • Analysis Centers • Data Centers • Earthquake/Tectonics • Earth Rotation • El Niño and La Niña • Gravity • Laser Safety • Other Geodesy • Satellite Missions • Stations • Useful • Y2K 	<ul style="list-style-type: none"> • Analysis Reports • Bulletins • Campaign Reports • Data Center Reports • ILRS Meetings Reports • Laser Workshop Reports • Network Reports • Performance Report Card • Press Releases • SLR/LLR CSTG Reports • SLRMail and SLReport • Special Reports • Station Data Anomalies • Station Status Reports • Technical Papers • Trip Reports 	<ul style="list-style-type: none"> • Analysis WG Charter • Analysis WG Members • Analysis WG Activities • DFandP WG Charter • DFandP WG Members • DFandP WG Activities • LEO Rapid Predictions • Missions WG Charter • Missions WG Members • Missions WG Activities • NandE WG Charter • NandE WG Members • NandE WG Activities • SP (Tiger) WG Charter • SP (Tiger) WG Members • SP (Tiger) WG Activities

8.4 NETWORK PERFORMANCE REPORT CARD FOR 1999

In addition to the report card, the following graphs are available from the ILRS Web Site:

- Total Data Volume (January 1999 - December 1999) by passes or by normal points
- LEO Satellite Data Volume (January 1999 - December 1999) by passes or by normal points
- LAGEOS Data Volume (January 1999 - December 1999) by passes or by normal points
- High Satellite Data Volume (January 1999 - December 1999) by passes or by normal points
- LAGEOS Single Shot RMS (4th Quarter 1999)
- LAGEOS Normal Point RMS (4th Quarter 1999)
- Short Term Bias Stability (4th Quarter 1999)
- Long Term Bias Stability (January 1999 - December 1999)
- Percentage of Good LAGEOS NP (4th Quarter 1999)

Special Note: This is the first report card that actually reflects the “true” pass totals. In previous report cards, the pass totals were actually the pass segments totals.

Below are the detailed descriptions of each column in the performance report card:

Column 1 is the station location name.

Column 2 is the monument marker number.

Column 3 is the LEO pass total during the past 12 months.

Column 4 is the LAGEOS pass total during the past 12 months.

Column 5 is the high satellite pass total during the past 12 months.

Column 6 is the pass total (i.e., all satellites) during the past 12 months.

Column 7 is the LEO NP total during the past 12 months.

Column 8 is the LAGEOS NP total during the past 12 months.

Column 9 is the high satellite NP total during the past 12 months.

Column 10 is the NP total (i.e., all satellites) during the past 12 months.

Column 11 is the average single-shot LAGEOS RMS, in millimeters, during the last quarter.

Column 12 is the average LAGEOS normal point RMS, in millimeters, during the last quarter, based on CSR Weekly LAGEOS analysis.

Column 13 is the measure of short term bias stability, in millimeters, during the last quarter. The short term stability is computed as the standard deviation about the mean of the pass-by-pass range biases from the CSR Weekly LAGEOS analysis.

Column 14 is the measure of long term bias stability, in millimeter, during the past year. A station must have tracked LAGEOS-1 in at least 8 of the last 12 months for a valid measurement. The long term stability is the standard deviation about the mean of the 15 day LAGEOS-1 range biases from CSR LAGEOS-1 long arc analysis.

Column 15 is the percentage of LAGEOS normal points that were accepted in CSR weekly LAGEOS analysis.

Column 16 is the average data latency time, in days, to the data centers, during the last quarter.

Column 17 is the ILRS normal point format revision number used within the last quarter.

Column 18 is a yes/no answer to the question of whether or not configuration files have been provided to the data centers.

Column 19 is a yes/no answer to the question of whether a station normal points comply with the ILRS Bin Size recommendations on all satellites.

The first entry in the table is the performance baseline goal. Note: There is no baseline goal for NP data quantities, single shot RMS, and normal point RMS.

Additional Notes: Blanks in any columns mean either that there was no data or that there was insufficient data. Only stations that have supplied data within the last year are included in the table. The table is sorted in descending order by total data volume.

ILRS Information

Column 1	Data Volume									Data Quality				Operational Compliance				
	2	3	4	5	6	7	8	9	10	11	12	13	14	15	16	17	18	19
System	Station	LEO Pass Total	LAG Pass Total	High Pass Total	LEO NP Total	LAGEOS NP Total	High NP Total	Total NP	SS RMS	NP RMS	Short Term	Long Term	% of accepted LAGEOS data	Delivery Days	Format Revision	Conf. Files	Bin Size Compliance	
Baseline		1000	400	100	1500							20	20	95	1	1	yes	yes
Monument Peak	7110	5579	1525	896	8000	86079	18344	8029	112452	8	2	11	5	98	1	1	yes	yes
Yarragadee	7090	3709	1052	1063	5824	58238	12562	8797	79597	10	2	11	5	97	1	1	yes	yes
Mt. Stromlo	7849	3370	1185	978	5533	35394	11259	4955	51608	11	2	15	6	98	1	1	yes	yes
Herstmonceux	7840	3085	984	751	4820	37704	12364	3553	53621	18	3	9	7	100	1	1	yes	yes
Greenbelt	7105	3347	833	375	4555	48031	9266	2418	59715	11	2	9	6	99	1	1	yes	yes
Graz	7839	2544	647	1091	4282	54342	10094	7626	72062	9	2	8	8	99	1	1	yes	yes
Wetzell	8834	1835	702	735	3272	29901	7144	4089	41134	28	6	18	10	99	1	1	yes	yes
Grasse	7835	2346	406	3	2755	46372	4924	44	51340	12	2	11	13	99	1	1	yes	yes
McDonald	7080	1755	497	396	2648	23558	4855	1615	30028	14	3	11	10	99	1	1	yes	yes
Changchun	7237	1584	463	466	2513	22281	4621	2755	29657	15	7	20	13	94	1	1	yes	yes
San Fernando	7824	1916	428	0	2344	28056	3422	0	31478	54	11	30	50	84	1	1	yes	yes
Potsdam	7836	1635	330	103	2068	21966	3029	480	25475	16	5	21	15	99	1	1	yes	yes
Zimmerwald	7810	1253	418	314	1985	17937	5463	2446	25846	45	11	11	10	98	1	1	yes	yes
Matera	7939	1216	449	0	1665	20949	5470	0	26419	145	29	38	9	54	1	1	yes	yes
Arequipa	7403	1319	209	0	1528	16024	1876	0	17900	7	3	20	15	96	1	1	yes	yes
Shanghai	7837	841	245	372	1458	12014	2472	2261	16747	18	7	25	14	94	1	1	yes	yes
Helwan	7831	1331	56	0	1387	15214	300	0	15514					19	1	0	yes	yes
Tahiti	7124	827	235	38	1100	10803	2317	293	13413							1	yes	
Borowiec	7811	719	292	42	1053	11662	3443	161	15266	33	8	18	16	98	1	1	yes	yes
Beijing	7249	694	187	96	977	9225	1443	493	11161	29	7	44		70	1	1	yes	yes
Koganei	7328	587	242	73	902	6849	2355	362	9566	12	4	19	12	99	1	1	yes	yes
Riga	1884	581	222	0	803	12587	3070	0	15657	25	7	47	18	75	1	1	yes	yes
Grasse (LLR)	7845	0	229	538	767	0	4083	3873	7956	26	4	12	12	99	1	1	yes	yes
Simosato	7838	572	120	25	717	9458	1249	162	10869	25	8	21		89	1	0	no	yes
Komsomolsk	1868	442	116	115	673	5092	725	374	6191		19	21		74	5	0	no	no
Haleakala	7210	403	130	138	671	5300	1260	1319	7879								yes	
Tateyama	7339	427	152	69	648	4922	1829	305	7056	14	3	14		100	1	1	yes	yes
Maidanak 2	1864	214	209	222	645	2682	1565	760	5007		8	19	17	93	2	0	no	no
Kashima	7335	409	131	54	594	5289	1293	216	6798	12	3	15		98	1	1	yes	yes
Metsahovi2	7806	480	71	15	566	8377	862	52	9291	33	8	25		95	1	1	yes	yes
Mendeleev	1870	439	0	0	439	3334	0	0	3334						2	0	no	no
Cagliari	7548	340	76	8	424	5522	506	39	6067					22	1	0	no	yes
Kunming	7820	154	201	63	418	2408	2024	351	4783	36	8	87		21	1	0	no	yes
Miura	7337	263	74	10	347	3019	671	47	3737	12	3	13		100	1	1	yes	yes
Wuhan	7236	9	18	30	57	75	147	261	483								no	
Katsively	1893	7	25	9	41	131	173	35	339	57	9	31		91	2	0	no	no

8.5 ILRS NETWORK STATISTICS

8.5.1 SLR POINT TOTALS BY STATION FOR 1999

Site Name	Station	GFZ-1	SUNSAT	ERS-1	ERS-2	GEOS-3	STAR	STEL	WEST	GFO-1	BE-C	TOPEX	AJISALAG-1	LAG-2	ETA-1	ETA-2	GPS-35	GPS-36	Moon	Totals	
Arequipa	7403	0	39	117	122	13	180	155	2	74	76	273	268	94	116	0	0	0	0	1,529	
Beijing	7249	0	6	47	41	17	80	76	11	33	81	137	165	107	89	3	10	0	0	903	
Borowiec	7811	0	1	103	97	36	68	72	16	45	21	158	102	183	112	0	0	1	0	1,015	
Cagliari	7548	0	1	46	56	7	25	27	1	11	1	62	103	35	41	0	0	0	0	416	
Changchun	7237	0	6	97	103	88	247	133	10	65	150	317	368	247	217	41	53	0	0	2,142	
Grasse	7835	4	54	346	355	60	275	285	164	129	65	393	216	213	193	0	2	0	1	2,755	
Grasse	7845	0	0	0	0	0	0	0	0	0	0	0	132	97	51	46	119	89	627	1,161	
Graz	7839	1	63	297	308	130	310	272	116	130	86	482	354	369	280	58	74	68	53	3,451	
Greenbelt	7105	0	125	241	223	107	583	258	90	259	279	472	710	489	372	22	27	1	6	4,264	
Haleakala	7210	0	0	49	45	24	43	48	14	26	7	73	74	69	68	5	0	3	0	548	
Helwan	7831	0	20	101	113	29	151	150	2	46	201	225	294	33	26	0	0	0	0	1,391	
Herstmonceux	7840	6	103	293	302	118	398	329	179	220	81	560	496	565	419	70	78	55	46	4,318	
Kashima	7335	0	8	9	16	1	80	44	9	2	52	53	135	59	72	4	4	0	0	548	
Katziely	1893	0	0	0	0	0	0	0	0	0	1	4	2	14	11	0	0	0	0	32	
Koganei	7328	0	5	20	36	3	98	70	14	8	67	88	178	107	135	7	14	0	0	850	
Komsomolsk	1868	0	0	67	60	0	38	53	12	0	5	104	103	68	62	35	18	0	5	630	
Kunming	7820	0	0	0	0	0	7	16	0	0	8	55	68	73	128	4	4	0	3	366	
Maidanak	1864	0	0	26	72	0	0	0	53	0	0	63	0	128	104	34	32	19	18	549	
Matera	7939	0	0	76	106	31	214	81	1	51	68	294	294	265	185	0	0	0	0	1,666	
McDonald	7080	0	24	161	166	83	188	157	17	105	194	331	329	256	269	14	15	4	6	2,485	
Mendeleev	1870	0	0	93	84	0	34	51	44	37	0	56	41	0	0	0	0	0	0	440	
Metsahovi	7806	0	12	70	74	23	26	48	3	68	0	90	66	37	34	4	2	0	0	557	
Miura	7337	0	0	3	12	2	34	28	1	2	42	46	93	41	33	0	0	0	0	337	
Monument Peak	7110	0	160	391	398	159	858	458	173	379	536	818	1,249	875	727	63	88	20	20	7,372	
Mt. Stromlo	7849	0	37	258	284	56	696	318	144	93	1	566	918	647	544	91	70	3	13	4,739	
Tahiti	7124	0	5	75	74	37	108	99	39	51	9	150	180	117	120	0	0	0	0	1,064	
Potsdam	7836	1	74	205	193	72	181	196	51	100	26	319	217	208	123	0	0	2	0	1,968	
Riga	1884	1	0	206	207	1	0	0	14	31	9	81	31	151	71	0	0	0	0	803	
San Fernando	7824	0	79	215	203	1	265	238	45	127	141	259	344	253	180	0	0	0	0	2,350	
Sarapul	1871	0	0	0	0	0	0	0	0	0	0	1	0	0	0	0	0	0	0	1	
Shanghai	7837	0	19	39	47	13	108	99	19	29	93	133	243	124	121	17	15	0	0	1,119	
Simosato	7838	0	7	42	40	20	76	56	8	18	54	78	173	50	70	8	8	0	0	708	
Tateyama	7339	0	3	12	23	3	71	53	17	3	56	65	121	70	82	6	12	0	0	597	
Wetzell	8834	0	16	112	147	16	304	184	17	75	83	464	417	411	309	71	87	70	43	2,826	
Wuhan	7236	0	0	0	0	0	1	2	0	0	0	3	2	8	10	3	0	0	0	29	
Yarragadee	7090	1	176	325	327	144	528	331	206	345	0	547	777	571	490	179	149	54	52	5,202	
Zimmerwald	7810	2	23	90	102	41	196	137	59	68	64	228	243	250	169	27	19	14	9	1,741	
Totals:		16	1,066	4,232	4,436	1,335	6,471	4,524	1,551	2,630	2,557	8,048	9,374	7,319	6,079	817	827	433	364	793	62,872

Name	Station	GLO-62	GLO-64	GLO-65	GLO-66	GLO-67	GLO-68	GLO-69	GLO-70	GLO-71	GLO-72	GLO-75	GLO-76	GLO-77	GLO-79	GLO-80	GLO-81	GLO-82	Totals	Grand
Arequipa	7403	0	0	0	0	0	0	0	0	0	0	0	0	0	0	0	0	0	0	1,529
Beijing	7249	4	0	0	11	0	5	9	7	5	7	3	3	5	10	7	3	5	84	987
Borowiec	7811	1	0	0	11	0	1	5	4	2	10	0	0	0	11	0	0	0	45	1,060
Cagliari	7548	0	0	0	0	0	1	0	1	0	4	0	0	0	3	0	0	0	9	425
Changchun	7237	13	0	0	23	2	21	28	24	10	67	20	22	37	51	36	13	14	381	2,523
Grasse	7835	0	0	0	0	0	0	0	0	0	0	0	0	0	0	0	0	0	0	2,755
Grasse	7845	30	0	0	32	0	19	34	85	85	131	0	0	0	119	5	0	0	540	1,701
Graz	7839	60	0	0	74	0	46	64	62	68	108	57	66	83	70	27	29	27	841	4,292
Greenbelt	7105	9	0	0	22	0	36	28	64	19	126	0	0	0	111	25	17	6	463	4,727
Haleakala	7210	22	0	0	18	0	28	6	32	22	25	0	0	0	18	0	1	0	172	720
Helwan	7831	0	0	0	0	0	0	0	0	0	0	0	0	0	0	0	0	0	0	1,391
Herstmonceux	7840	29	0	1	37	40	46	45	70	30	88	0	0	0	104	13	0	0	503	4,821
Kashima	7335	0	0	0	6	0	2	6	9	2	3	0	0	0	7	4	4	3	46	594
Katziely	1893	0	0	0	0	0	0	0	0	0	2	0	0	0	6	1	0	0	9	41
Koganei	7328	2	0	0	1	0	3	2	4	6	18	0	0	0	10	5	1	0	52	902
Komsomolsk	1868	0	0	0	18	0	0	0	0	15	13	0	0	0	5	10	0	0	61	691
Kunming	7820	2	1	0	2	0	1	9	5	6	16	1	2	1	6	0	0	0	52	418
Maidanak	1864	3	0	0	14	0	10	15	20	10	29	1	0	0	32	5	0	0	139	688

Komsomolsk	1868	0	0	0	38	0	0	0	0	108	37	0	0	0	7	16	0	0	206	6,205
Kunming	7820	13	5	0	9	0	4	67	22	35	83	4	8	6	25	0	0	0	281	4,783
Maidanak	1864	8	0	0	47	0	21	33	49	84	91	3	0	0	99	8	0	0	443	5,015
Matera	7939	0	0	0	0	0	0	0	0	0	0	0	0	0	0	0	0	0	0	26,419
McDonald	7080	99	0	0	88	10	58	64	188	118	259	0	0	0	302	29	48	12	1,275	30,121
Mendeleevo	1870	0	0	0	0	0	0	0	0	0	0	0	0	0	0	0	0	0	0	3,334
Metsahovi	7806	0	0	0	0	0	7	0	0	0	16	0	0	0	3	20	0	0	46	9,311
Miura	7337	9	0	0	0	0	5	0	0	0	30	0	0	0	3	0	0	5	52	3,742
Monument Peak	7110	326	0	0	322	0	536	493	1,008	366	2,205	0	0	0	1,849	155	219	109	7,588	112,934
Mt. Stromlo	7849	298	0	0	289	0	246	234	547	300	1,036	0	0	0	1,001	125	44	15	4,135	51,793
Potsdam	7836	15	0	0	59	0	47	57	53	54	81	0	0	0	105	0	0	0	471	25,457
Riga	1884	0	0	0	0	0	0	0	0	0	0	0	0	0	0	0	0	0	0	15,657
San Fernando	7824	0	0	0	0	0	0	0	0	0	0	0	0	0	0	0	0	0	0	31,455
Shanghai	7837	85	0	0	231	58	139	182	195	97	314	148	120	220	243	72	58	97	2,259	16,974
Simosato	7838	0	0	0	7	0	0	7	6	7	17	0	0	0	16	0	0	0	60	10,869
Tahiti	7124	58	0	0	14	0	17	31	102	11	43	0	0	0	17	0	2	0	295	#REF!
Tateyama	7339	25	0	0	7	0	25	4	19	9	61	0	0	0	63	27	0	0	240	7,083
Wettzell	8834	159	0	0	78	0	259	234	450	125	540	115	104	120	677	39	0	0	2,900	41,173
Wuhan	7236	0	0	0	18	35	48	16	50	14	9	20	9	9	14	0	0	0	242	477
Yarragadee	7090	609	0	0	495	0	235	304	826	573	1,863	0	0	0	1,747	416	121	20	7,209	80,115
Zimmerwald	7810	193	0	0	100	0	188	208	361	114	337	0	0	0	515	45	0	0	2,061	25,891
Totals:		2,926	5	2	3,147	289	3,078	3,240	5,840	3,504	10,357	809	839	1,178	9,490	1,704	896	592	47,896	888,548

Table 8.5.2-3

8.6 ILRS COMPONENTS

ILRS Central Bureau

NASA Goddard Space Flight Center (GSFC), USA

Global Data Centers

Crustal Dynamics Data Information System (CDDIS), NASA GSFC, USA

EUROLAS Data Center (EDC), Deutsches Geodätisches Forschungsinstitut (DGFI), Germany

Regional Data Centers

Shanghai Observatory, Academia Sinica, China

Operations Center

Russian Mission Control Center (MCC), Russia

University of Texas at Austin, Center for Space Research (CSR), USA

NASA Goddard Space Flight Center (NASA GSFC), USA

University of Texas at Austin, USA

Analysis Centers

Delft University of Technology (DUT), The Netherlands

Russian Mission Control Center (MCC), Russia

University of Texas at Austin, Center for Space Research (CSR), USA

Lunar Analysis Centers

Observatoire de Paris, France

Forschungseinrichtung Satellitengeodäsie (FESG), Germany

Jet Propulsion Laboratory (JPL), USA

University of Texas at Austin, USA

Associate Analysis Centers

Austrian Academy of Sciences, Austria

Australian Surveying and Land Information Group (AUSLIG), Australia

Academia Sinica, China

Observatoire de la Côte d'Azur/Centre d'Etudes et de Recherches Géodynamiques et

Astrométrie (OCA/CERGA), France

Bundesamt für Kartographie und Geodäsie (BKG), Germany

Deutsches Geodätisches Forschungsinstitut (DGFI), Germany

European Space Agency/ESA Space Operations Center (ESA/ESOC), Germany

GeoForschungsZentrum, Germany

Agenzia Spaziale Italiana/Centro de Geodesia Spaziale (ASI/CGS), Italy

Forsvarets Forskningsinstitutt (Norwegian Defence Research Establishment), Norway

Institute of Applied Astronomy, Russia

Institute of Astronomy of the Russian Academy of Sciences, Russia

Institute of Metrology for Time and Space, Russia

Astronomical Institute, University of Berne (AIUB), Switzerland

Main Astronomical Observatory of the National Academy of Sciences of the Ukraine

(GAOUA), Ukraine

Aston University, United Kingdom

Natural Environment Research Council, United Kingdom

NASA Goddard Space Flight Center (GSFC), USA

Stations/Subnetworks

MOBLAS-5 (AUSLIG and NASA), Australia

Mt. Stromlo (AUSLIG), Australia

Graz (Austrian Academy of Sciences), Austria

Beijing (Chinese Academy of Surveying and Mapping), China

Changchun, Kunming, Shanghai (Chinese Academy of Sciences), China
Wuhan (State Seismological Bureau), China
Helwan Observatory, Egypt
Metsahovi (Finnish Geodetic Institute), Finland
FTLRS, Grasse LLR and SLR (GRGS/CNES), France
MTLRS-1, TIGO-SLR, WLRs (BKG), Germany
Potsdam (GFZ), Germany
MLRO and SAO-1 Matera (ASI/CGS), Italy
Astronomical Observatory of Cagliari, Italy
KEYSTONE (CRL), Japan
Simosato (JHD), Japan
Riga (Astronomical Institute of University of Latvia), Latvia
MTLRS-2 (DUT), The Netherlands
TLRS-3 (NASA), Peru
Borowiec (Space Research Centre of PAS), Poland
Mendeleev (IMVP VNIIFTRI), Russia
Komsomolsk (RSA and SRI for Precision Instrument Engineering), Russia
SALRO (KACST), Saudi Arabia
San Fernando (Real Instituto y Observatorio de la Armada), Spain
Zimmerwald (AIUB), Switzerland
Katzively (RSA and SRI for Precision Instrument Engineering), Ukraine
Kiev (GAOUA), Ukraine
Simeiz, Ukraine
Herstmonceux (NERC), United Kingdom
MOBLAS-8 (NASA and UPF), French Polynesia
MOBLAS-4, -6, -7, TLRS-4, HOLLAS, MLRS (NASA), USA
Maidanak (RSA and SRI for Precision Instrument Engineering), Uzbekistan

8.7 ILRS PARTICIPATING INSTITUTIONS

Agency	Country
Australian Surveying and Land Information Group (AUSLIG)	Australia
Austrian Academy of Sciences	Austria
Academia Sinica	China
Chinese Academy of Surveying and Mapping	China
State Seismological Bureau	China
Yunnan Observatory	China
Technical University of Prague	Czech Republic
National Research Institute of Astronomy and Geophysic (NRIAG)	Egypt
Finnish Geodetic Institute	Finland
Observatoire de la Côte d'Azur/Center d'Etudes et de Recherches Géodynamiques et Astrométrie (OCA/CERGA)	France
Observatoire de Paris	France
Bundesamt für Kartographie und Geodäsie (BKG)	Germany
Deutsches Geodätisches Forschungsinstitut (DGFI)	Germany
European Space Agency (ESA)	Germany
Forschungseinrichtung Satellitengeodäsie (FESG), Technical University of Munich	Germany
GeoForschungsZentrum (GFZ)	Germany
Astronomical Observatory of Cagliari	Italy
Italian Space Agency (ASI)	Italy
Communications Research Laboratory (CRL)	Japan
Japanese Hydrographic Department (JHD)	Japan
Astronomical Observatory, University of Latvia	Latvia
Division for Electronics, Forsvarets Forskningsinstitutt (FFI)	Norway
Space Research Center of the Polish Academy of Sciences (PAS)	Poland
Institute of Applied Astronomy (IAA)	Russia
Institute of Astronomy of the Russian Academy of Sciences (INASAN)	Russia
Institute of Metrology for Time and Space (IMVP)	Russia
Mission Control Center (MCC)	Russia
Space Research Institute (SRI) for Precision Instrument Engineering	Russia
King Abdulaziz City for Science and Technology (KACST)	Saudi Arabia
Real Instituto y Observatorio de la Armada	Spain
Astronomical Institute, University of Berne (AIUB)	Switzerland
Delft University of Technology (DUT)	The Netherlands
Crimean Astronomical Observatory	Ukraine
Lebedev Physical Institute in the Crimea	Ukraine
Main Astronomical Observatory (MAO) of the National Academy of Sciences of Ukraine	Ukraine
Aston University	United Kingdom

Natural Environment Research Council (NERC)	United Kingdom
University of Newcastle Upon Tyne	United Kingdom
Jet Propulsion Laboratory (JPL)	USA
National Aeronautics and Space Administration Goddard Space Flight Center (NASA GSFC)	USA
University of Hawaii	USA
University of Texas at Austin	USA
University of Texas, Center for Space Research (CSR)	USA

8.8 ILRS ASSOCIATES

ILRS ASSOCIATES

Name	Organization	Country	E-Mail
Igors Abakumovs	Astronomical Institute, University of Latvia	Latvia	riglas@lanet.lv
Fahad Al-Zaaydey	KACST/Institute of Space Research	Saudi Arabia	alghamdi@kacst.edu.sa
Jun Amagai	Communications Research Laboratory	Japan	amagai@crl.go.jp
Dr. Per Helge Andersen	Division for Electronics (FFI)	Norway	per-helge.andersen@ffi.no
Dr.-Ing. Detlef Angermann	DGFI/Abt. 1	Germany	angerman@dgfi.badw.de
Graham Appleby	ITE Monks Wood	United Kingdom	gapp@mail.nerc-monkswood.ac.uk
Helmy Awad	NRIAG	Egypt	slregypt@intouch.com
Dr. Aldo Banni	Astronomical Observatory of Cagliari	Italy	banni@ca.astro.it
Louis Barendse	Hartebeesthoek Radio Astronomy Observatory	South Africa	louis@hartrao.ac.za
Peter Bargewell	KACST/Inst. of Astronomy & Geophysics	Saudi Arabia	moblas@midwest.com.au
Dr. Francois Barlier	CERGA/GRGS	France	francois.barlier@obs-azur.fr
Jacek Bartoszak	Space Research Center of the PAS	Poland	laser@cbk.poznan.pl
Gerald Baustert	GeoForschungsZentrum Potsdam	Germany	gerald.baustert@dlr.de
Cheng Behui	Beijing Station	China	wangtq@sun.ihep.ac.cn
David Benham	NERC Space Geodesy Facility	United Kingdom	slr@slrb.ngo.ac.uk
Johan Bernhardt	Hartebeesthoek Radio Astronomy Observatory	South Africa	johan@hartrao.ac.za
Prof. Gerhard Beutler	Astronomical Institute of Berne	Switzerland	beutler@aib.unibe.ch
Dr. Giuseppe Bianco	Agenzia Spaziale Italiana (ASI)	Italy	bianco@asi.it
Patrick Bidart	Observatoire de Paris	France	bidard@danof.obspm.fr
Matthew Bieneman	HTSI/SLR	United States	matthew.bieneman@honeywell-tsi.com
Nicolas Blanchard	Tahiti Geodetic Observatory	French Polynesia	blanchar@warhol.ufp.pf
Maceo Blount	MOBLAS-7, c/o HTSI SLR	United States	maceo.blount@honeywell-tsi.com
Armin Boer	BKG, Fundamentalstation Wettzell	Germany	boer@wettzell.ifag.de
Dale H. Boggs	JPL/Mail Stop 238-332	United States	dale.boggs@jpl.nasa.gov
Pascal Bonnefond	OCA/CERGA/GRGS	France	pascal.bonnefond@obs-azur.fr
Alain Bonneville	Tahiti Geodetic Observatory, UFP	French Polynesia	bonnevil@ipgp.jussieu.fr
John M. Bosworth	NASA GSFC, Code 920.1	United States	jmb@ltpmail.gsfc.nasa.gov
Oscar L. Brogdon	HTSI/SLR	United States	oscar.brogdon@honeywell-tsi.com
Mark Broomhall	Remote Sensing & Satellite Research Group	Australia	m.a.broomhall@curtin.edu.au
Franco Buffa	Stazione Astronomica di Cagliari	Italy	fbuffa@ca.astro.it
Edward Butkiewicz	Space Research Center of the PAS	Poland	ebut@cbk.poznan.pl
Randall Carman	MOBLAS-5	Australia	moblas@midwest.com.au
David L. Carter	NASA GSFC	United States	dlcarter@pop900.gsfc.nasa.gov
Tomasz Celka	Space Research Centre of PAS	Poland	celka@cbk.poznan.pl
Jean Chapront	Observatoire de Paris	France	jean.chapront@obspm.fr
Michelle Chapront-Touze	Observatoire de Paris	France	michelle.chapront@obspm.fr
John W. Cheek	NASA GSFC/Raytheon ITSS	United States	cheek@cddis.gsfc.nasa.gov
Prof. Dr. Junyong Chen	Beijing Station	China	jychen@sun.ihep.ac.cn
Dr. Minkang Cheng	U. of Texas, Center for Space Research	United States	cheng@csr.utexas.edu
Hunag Cheng	Shanghai Associate Analysis Center	China	hc@center.shao.ac.cn
Christopher (Bart) Clarke	HTSI/SLR	United States	christopher.clarke@honeywell-tsi.com
Ludwig Combrinck	Hartebeesthoek Radio Astronomy Observatory	South Africa	ludwig@bootes.hartrao.ac.za
Etienne Cuot	CERGA	France	cuot@obs-azur.fr
Karl Daues	Tahiti Geodetic Observatory	French Polynesia	daues@warhol.ufp.pf
Jose Martin Davilla	Real Instituto y Observatorio Armada	Spain	geofisica@roa.es
George Davisson	HTSI/SLR	United States	george.davisson@honeywell-tsi.com
Dr. John J. Degnan	NASA GSFC, Code 920.3	United States	jjd@ltpmail.gsfc.nasa.gov
Dr. Jean O. Dickey	JPL/Mail Stop 238-332	United States	jean.o.dickey@jpl.nasa.gov
Andrew I. Dmitrova	Simeiz	Ukraine	dmai@crao.crimea.ua
Buddy Donovan	HTSI/SLR	United States	howard.donovan@honeywell-tsi.com
Ted Doroski	MOBLAS-4	United States	m4mgr@slra12.atsc.allied.com

Dr. John M. Dow	European Space Agency	Germany	jdow@esoc.esa.de
Dr. Hermann Drewes	DGFI/Dept. I	Germany	drewes@dgfi.badw.de
Dr. Maurice P. Dube	NASA GSFC/Raytheon ITSS	United States	dube@cddis.gsfc.nasa.gov
Peter J. Dunn	NASA GSFC/Raytheon ITSS	United States	peter_j_dunn@raytheon.com
Richard J. Eanes	U. of Texas, Center for Space Research	United States	eanes@csr.utexas.edu
Dieter Egger	Forschungseinrichtung Satellitengeodasie	Germany	dieter.egger@bv.tum.de
Attalla EL Azab	NRIAG	Egypt	slregypt@intouch.com
Mohamed EL Helali	NRIAG	Egypt	slregypt@intouch.com
Abd EL Rohman Ahmed	NRIAG	Egypt	slregypt@intouch.com
Dr. Magdy EL Saftawy	NRIAG	Egypt	slregypt@intouch.com
K. Elango	ISTRAC/ISRO	India	elango@istrac.gov.in
Pierre Exertier	OCA/CERGA/GRGS	France	pierre.exertier@obs-azur.fr
Sami Fathallah	NRIAG	Egypt	slregypt@intouch.com
He-Sheng Feng	Yunnan Observatory	China	yozsx@public.km.yn.cn
Qu Feng	Beijing Station	China	wangtq@sun.ihep.ac.cn
He-Sheng Feng	Yunnan Observatory	China	yozsx@public.km.yn.cn
Dominique Feraudy	CERGA/OCA/GRGS	France	feraudy@obs-azur.fr
Sergey V. Filikov	Simeiz	Ukraine	flikov@crao.crimea.ua
Dr. Harald Fischer	GeoForschungsZentrum Potsdam	Germany	fisch@gfz-potsdam.de
Beate Forberg	DFGI	Germany	edc@dgfi.badw-muenchen.de
Craig Foreman	LURE Observatory	United States	foreman@banana.ifa.hawaii.edu
Gerard Francou	Observatoire de Paris	France	francou@bdl.fr
Dr. Masayuki Fujita	Hydrographic Dept./Ocean Research Laboratory	Japan	mfuji@cue.jhd.go.jp
Dr. Yang Fumin	Shanghai Obs/Academia Sinica	China	yangfm@center.shao.ac.cn
Maurice Furia	OCA/CERGA	France	maurice.furia@obs-azur.fr
Yue Gao	EOS	Australia	stromlo_slr@eos-aus.com
Jorge Garate	Real Instituto y Observatorio Armada	Spain	jgarate@roa.es
Dr. Iskander Gayazov	Institute of Applied Astronomy	Russia	gayazov@quasar.ipa.nw.ru
Gary Gebet	NASA Tracking Station/MOBLAS-4	United States	m4mgr@slr12.atsc.allied.com
Michael Gerstl	DGFI	Germany	gerstl@dgfi.badw-muenchen.de
Philip Gibbs	NERC Space Geodesy Facility	United Kingdom	slr@slrb.rgo.ac.uk
Monique Glentzin	OCA/CERGA	France	monique.glentzin@obs-azur.fr
Vladimir D. Glotov	Russian Mission Control Centre (MCC)	Russia	bulmon@podlipki.ru
Mariano Gomez	Avenida Parra Pasaje	Peru	t3mgr@unsa.edu.pe
Dr. Ramesh Govind	AUSLIG, Geodesy Unit	Australia	rameshgovind@auslig.gov.au
Dr. Ben A. Greene	Western Pacific Laser Tracking Network	Australia	eos@dynamite.com.au
Dr. Ludwig Grunwaldt	GeoForschungsZentrum Potsdam	Germany	grun@gfz-potsdam.de
Tangyong Guo	State Seismological Bureau	China	whslr@public.wh.hb.cn
Dr. Werner Gurtner	Astronomical Institute of Berne	Switzerland	gurtner@aiub.unibe.ch
Kenny T. Harned	McDonald Observatory	United States	kh@ranger.as.utexas.edu
Hermann Hauck	BKG	Germany	hauck@ifag.de
Wilhelm Haupt	Hartebeesthoek Radio Astronomy Observatory	South Africa	wilhelm@hartrao.ac.za
Walter Hausleitner	Austrian Academy of Sciences	Austria	walter.hausleitner@oeaw.ac.at
Miaochan He	Yunnan Observatory	China	yozsx@public.km.yn.cn
J. Michael Heinick	HTSI/SLR	United States	michael.heinick@honeywell-tsi.com
Julie E. Horvath	HTSI/SLR	United States	julie.horvath@honeywell-tsi.com
Van S. Husson	HTSI/SLR	United States	van.husson@honeywell-tsi.com
Dr. Makram Ibrahim	NRIAG	Egypt	slregypt@intouch.com
Chongguo Jiang	Yunnan Observatory	China	yozsx@public.km.yn.cn
Alain Journet	OCA/CERGA	France	alain.journet@obs-azur.fr
Dr. Klaus Kaniuth	DGFI	Germany	kaniuth@dgfi.badw-muenchen.de
Dr. Futaba Katsuo	Communications Research Laboratory	Japan	futaba@crl.go.jp
Dr. Mark Kaufman	IMPV	Russia	mark@imvp.aspnet.ru
Rainer Kelm	DGFI	Germany	kelm@dgfi.badw-muenchen.de
Ruth Kennard	NASA GSFC/Raytheon ITSS	United States	kennard@cddis.gsfc.nasa.gov
Dr. Georg Kirchner	Austrian Academy of Sciences	Austria	kirchner@flubpc04.tu-graz.ac.at
Steve M. Klosko	NASA GSFC/Raytheon ITSS	United States	steven_m_klosko@raytheon.com
Dr. Rolf Koenig	GeoForschungsZentrum Potsdam	Germany	rolf.koenig@gfz-potsdam.de
Yuri L. Kokurin	s. Katzively	Ukraine	root@clo.ylt.crimea.com
Ronald Kolenkiewicz	NASA GSFC, Code 926	United States	ronk@ltpmail.gsfc.nasa.gov
Dr. Georgy Krasinsky	Institute of Applied Astronomy	Russia	kra@quasar.ipa.nw.ru
Jeff Kuhn	LURE Observatory	United States	kuhn@ifa.hawaii.edu
Dirk Kuijper	European Space Agency	Germany	dkuijper@esoc.esa.de

ILRS Information

Hiroo Kunimori	Communications Research Laboratory	Japan	kuni@crl.go.jp
Vladislav Kurbasov	s. Katzively	Ukraine	root@clo.ylt.crimea.com
Dr. Maurice Laplanche	OCA/CERGA	France	maurice.laplanche@obs-azur.fr
Valdis Laposhka	Astronomical Institute, University of Latvia	Latvia	riglas@lanet.lv
Dr. Kasimirs Lapushka	Astronomical Institute, University of Latvia	Latvia	riglas@lanet.lv
Dr. Jan Latka	Space Research Centre of PAS	Poland	jkl@cbk.waw.pl
Olivier Laurain	OCA/CERGA	France	olivier.laurain@obs-azur.fr
Lesiba Ledwaba	Hartebeesthoek Radio Astronomy Observatory	South Africa	lesiba@hartrao.ac.za
Frank G. Lemoine	NASA GSFC, Code 926	United States	flemoine@ares.gsfc.nasa.gov
Bill Lindsey	LURE Observatory	United States	lindsey@banana.ifa.hawaii.edu
Victor Lucano	Avenida Parra Pasaje	Peru	t3mgr@unsa.edu.pe
Dr. Vincenza Luceri	Telespazio S.p.A.	Italy	luceri@asi.it
Dr. John Mck. Luck	AUSLIG/Dept. Adm. Services	Australia	johnluck@auslig.gov.au
Vadim Lunev	Simeiz	Ukraine	simeiz@mail.ylt.crimea.com
Mike Maberry	LURE Observatory	United States	maberry@hawaii.edu
Dr. Zinovy Malkin	Institute of Applied Astronomy	Russia	malkin@quasar.ipa.nw.ru
Jean-Francois Mangin	OCA/CERGA	France	mangin@obs-azur.fr
John Manning	AUSLIG, Geodesy Unit	Australia	johnmanning@auslig.gov.au
Dr. Maria Mareyen	BKG	Germany	mamy@ifag.de
Franz-Heinrich Massmann	GFZ/D-PAF	Germany	fhm@gfz-potsdam.de
Jan F. McGarry	NASA GSFC, Code 920.3	United States	mcgarry@cdis.gsfc.nasa.gov
Dr. Mikhail Medvedskij	NASA	Ukraine	medved@mao.kiev.ua
Francois Mignard	OCA/CERGA	France	francois.mignard@obs-azur.fr
Oleg Minin	Simeiz	Ukraine	simeiz@mail.ylt.crimea.com
Vladimir Mitrikas	Russian Mission Control Centre	Russia	geozup@cityline.ru
Piet Mohlabeng	Hartebeesthoek Radio Astronomy Observatory	South Africa	solly@hartrao.ac.za
Chris Moore	EOS Pty. Ltd.	Australia	chris-moore@mail.com
Dr. Philip Moore	Aston University	United Kingdom	philip.moore@newcastle.ac.uk
William Moralo	Hartebeesthoek Radio Astronomy Observatory	South Africa	willy@hartrao.ac.za
Dr. Ing. Juergen Mueller	Technical University of Munich	Germany	jxmx@bv.tum.de
Horst Mueller	DGFI/Abt. 1	Germany	mueller@dgfi.badw.de
Leonardo Mureddu	Astronomical Observatory of Cagliari	Italy	mureddu@ca.astro.it
Olga Nagomuk	Simeiz	Ukraine	simeiz@mail.ylt.crimea.com
Liu Nailing	Beijing Station	China	wangtq@sun.ihep.ac.cn
Dr. Reinhart Neubert	GeoForschungsZentrum Potsdam	Germany	neub@gfz-potsdam.de
Dmitriy Neyachenko	Simeiz	Ukraine	simeiz@mail.ylt.crimea.com
Marisa Nickola	Hartebeesthoek Radio Astronomy Observatory	South Africa	marisa@hartrao.ac.za
Joelle Nicolas	OCA/CERGA	France	joelle.nicolas@obs-azur.fr
Carey E. Noll	NASA GSFC, Code 920.1	United States	noll@cdis.gsfc.nasa.gov
Ron Noomen	Delft University of Technology	The Netherlands	ron.noomen@deos.tudelft.nl
Dr. Antonin Novotny	Technical University of Prague	Czech Republic	novotny@troja.fjfi.cvut.cz
Vince Noyes	MOBLAS-5 Tracking Station	Australia	moblas@midwest.com.au
Dan Nugent	HTSI/SLR	United States	daniel.nugent@honeywell-tsi.com
Daniel J. O'Gara	University of Hawaii	United States	ogara@ifa.hawaii.edu
Jacek Offierski	Delft University of Technology	The Netherlands	joffi@geo.tudelft.nl
Thomas Oldham	HTSI/SLR	United States	thomas.oldham@honeywell-tsi.com
Toshimichi Otsubo	Communications Research Laboratory	Japan	otsubo@crl.go.jp
Gert-Jan Ourensma	Faculty of Aerospace Engineering	The Netherlands	gertjan.ourensma@lr.tudelft.nl
Jack Paff	MOBLAS-5	Australia	moblas@midwest.com.au
Mr. Jocelyn Paris	OCA/CERGA	France	jocelyn.paris@obs-azur.fr
Dr. Natalia Parkhomenko	SRI for Precision Instrument Engineering	Russia	natali@ricimi.msk.su
Richard Pastor	U. of Texas, Center for Space Research	United States	pastor@csr.utexas.edu
Dr. Matti Paunonen	Finnish Geodetic Institute	Finland	geodeet@csc.fi
Andris Pavenis	Astronomical Institute, Univ. of Latvia	Latvia	riglas@lanet.lv
Dr. Erricos C. Pavlis	NASA GSFC, Code 926/JCET-UMBC	United States	epavlis@ltpmail.gsfc.nasa.gov
Dr. Michael R. Pearlman	Harvard-Smithsonian Center for Astrophysics	United States	mpearlman@cfa.harvard.edu
Francis Pierron	Observatoire de la cote d'azur	France	francis.pierron@obs-azur.fr
Eugen Pop	Astronomical Institute of Berne	Switzerland	pop@aiub.unibe.ch
Xiang Qingge	Beijing Station	China	wangtq@sun.ihep.ac.cn
Manuel Quijano	Real Ins. y Observatorio de la Armada	Spain	mquijano@roa.es
William Raabe	MOBLAS-5	Australia	moblas@midwest.com.au
Jean-Claude Raimondo	GeoForschungsZentrum Potsdam	Germany	jean-claude.raimondo@dlr.de

Dr. Christoph Reigber	GeoForschungsZentrum Potsdam	Germany	reigber@gfz-potsdam.de
Sergei Revnivych	Russian Mission Control Centre	Russia	bulmon@podlipki.ru
Dr. Bernd Richter	BKG	Germany	richter@ifag.de
Randall L. Ricklefs	University of Texas at Austin	United States	rlr@astro.as.utexas.edu
Joachim Riedel	GeoForschungsZentrum Potsdam	Germany	jorie@gfz-potsdam.de
Stephan Riepl	BKG, Fundamentalstation Wettzell	Germany	riepl@wettzell.ifag.de
John C. Ries	U. of Texas, Center for Space Research	United States	ries@csr.utexas.edu
Judit Ries	McDonald Observatory	United States	moon@astro.as.utexas.edu
Markus Rothacher	Technische Universitaet Muenchen	Germany	rothacher@bv.tum.de
Sergei P. Rudenko	Main Astronomical Observatory	Ukraine	rudenko@mao.kiev.ua
Tarik Salim	NRIAG	Egypt	slregypt@intouch.com
Etienne Samain	OCA/CERGA	France	etienne.samain@obs-azur.fr
Remko Scharroo	Delft University of Technology/DEOS	The Netherlands	remko.scharroo@deos.tudelft.nl
Francesco Schiavone	ASI/CGS	Italy	laser@asi.it
Danuta Schillak	Space Research Centre of PAS	Poland	danka@cbk.poznan.pl
Dr. Stanislaw Schillak	Space Research Center of PAS	Poland	sch@cbk.poznan.pl
Anja Schlicht	Fundamentalstation Wettzell	Germany	schlicht@wettzell.ifag.de
Dr. Wolfgang Schlueter	Fundamentalstation Wettzell	Germany	schlueter@wettzell.ifag.de
Roland Schmidt	GFZ/OP c/o DLR	Germany	roland.schmidt@dlr.de
Dr. Ulrich Schreiber	Fundamentalstation Wettzell	Germany	schreiber@wettzell.ifag.de
Bruce R. Schupler	HTSI/VLBI	United States	bruce.schupler@honeywell-tsi.com
Dr. Bob E. Schutz	U. of Texas, Center for Space Research	United States	schutz@csr.utexas.edu
Dr. Cecilia Sciarretta	Telespazio S.p.A.	Italy	cecilia@asi.it
Ron Sebeny	MOBLAS-4	United States	m4mgr@slral2.atsc.allied.com
Wolfgang Seemueller	DGFI, Abt. I	Germany	seemueller@dgfi.badw-muenchen.de
Michael D. Selden	HTSI/SLR	United States	michael.selden@honeywell-tsi.com
Arata Sengoku	Hydrographic Dept./Japan Coast Guard	Japan	asengoku@ws04.cue.jhd.go.jp
Dr. Victor Shargorodsky	SRI for Precision Instrument Engineering	Russia	natali@ricimi.msk.su
Dr. Peter J. Shelus	University of Texas at Austin	United States	pjs@astro.as.utexas.edu
Robert Sherwood	NERC Space Geodesy Facility	United Kingdom	slr@slrb.rgo.ac.uk
Dr. Lazar Shtirberg	Simeiz	Ukraine	lazar@crao.crimea.ua
Mel Sigman	Hartebeesthoek Radio Astronomy Observatory	South Africa	mel@hartrao.ac.za
Diglio Simoni	HTSI/SLR	United States	diglio.simoni@honeywell-tsi.com
Dr. Andrew T. Sinclair		United Kingdom	atsinclair@aol.com
Dr. David E. Smith	NASA GSFC, Code 920	United States	dsmith@tharsis.gsfc.nasa.gov
Alain Spang	OCA/CERGA	France	alain.spang@obs-azur.fr
Tim Springer	Astronomical Institute of Berne	Switzerland	springer@aiub.unibe.ch
Peter Standen	NERC Space Geodesy Facility	United Kingdom	slr@slrb.rgo.ac.uk
Charles Steggerda	HTSI/SLR	United States	charlie.steggerda@honeywell-tsi.com
Paul Stevens	HTSI/SLR	United States	paul.stevens@honeywell-tsi.com
Ray Stringfellow	HTSI/SLR	United States	ray.stringfellow@honeywell-tsi.com
Pieter Stronkhorst	Hartebeesthoek Radio Astronomy Observatory	South Africa	pieter@hartrao.ac.za
Wang Tanquiang	Beijing Station	China	wangtq@sun.ihep.ac.cn
Dr. Suriya K. Tatevian	Inst. of Astronomy/RAS, Space Geodesy Dept.	Russia	statev@inasan.rssi.ru
Jean-Marie Torre	CERGA/GRGS	France	torre@obs-azur.fr
Mark H. Torrence	NASA GSFC/Raytheon ITSS	United States	mtorrenc@geodesy2.gsfc.nasa.gov
Ken Tribble	HTSI/SLR	United States	kenneth.tribble@honeywell-tsi.com
Vladimir Tryapitsin	s. Katzively	Ukraine	root@clo.ylt.crimea.com
Johannes Utzinger	Astronomical Institute of Berne	Switzerland	utzinger@aiub.unibe.ch
Jorge Valverde	Avenida Parra Pasaje	Peru	t3mgr@unsa.edu.pe
Danny van Loon	Delft University of Technology	The Netherlands	vanloon@geo.tudelft.nl
Prof. Vladimir P. Vasiliev	SRI for Precision Instrument Engineering	Russia	natali@ricimi.msk.su
Merle Vaughn	MOBLAS-4	United States	m4mgr@slral2.atsc.allied.com
Dr. Franco Vespe	ASI-Centro Geodesia Spaziale	Italy	vespe@asi.it
Gerard Vigouroux	OCA/CERGA	France	gerard.vigouroux@obs-azur.fr
Martin L. Villarreal	McDonald Observatory	United States	mv@ranger.as.utexas.edu
Herve Viot	OCA/CERGA	France	herve.viot@obs-azur.fr
David Walters	NERC Space Geodesy Facility	United Kingdom	slr@slrb.rgo.ac.uk
Wu Wang	Yunnan Observatory	China	yozsx@public.km.yn.cn
Scott L. Wetzel	HTSI/SLR	United States	scott.wetzel@honeywell-tsi.com
Jerry Wiant	MLRS Laser Project	United States	jr@astro.as.utexas.edu
Urs Wild	Swiss Fed. Office of Topography	Switzerland	urs.wild@lt.admin.ch

ILRS Information

Dr. James G. Williams	JPL/Mail Stop 238-332	United States	jgw@logos.jpl.nasa.gov
Windell L. Williams	MLRS Laser Project	United States	ww@ranger.as.utexas.edu
Dr. Roger Wood	NERC Space Geodesy Facility	United Kingdom	rw@slrb.rgo.ac.uk
Chen Xianjun	Beijing Station	China	wangtq@sun.ihep.ac.cn
Yaoheng Xiong	Yunnan Observatory	China	yoysx@public.km.yn.cn
Manuel Yanyache	Avenida Parra Pasaje	Peru	t3mgr@unsa.edu.pe
Dr. Dmitry Yatskiv	Ukraine	Ukraine	dmy@mao.kiev.ua
Prof. Yaroslav S. Yatskiv	Main Astronomical Observatory	Ukraine	yatskiv@mao.kiev.ua
Zhang Yian	Beijing Station	China	wangtq@sun.ihep.ac.cn
Zhao You	Changchun Satellite Observatory	China	zhxh@mail.jlu.edu.cn
Thomas W. Zagwodzki	NASA GSFC, Code 920.3	United States	thomas.w.zagwodzki@gssc.nasa.gov
Rene Zandbergen	European Space Agency	Germany	rzandber@esoc.esa.de
Stanislaw Zapasnik	Space Research Centre of PAS	Poland	zapasnik@cbk.poznan.pl
Shuxin Zhang	Yunnan Observatory	China	yoysx@public.km.yn.cn
Kiangming Zheng	Yunnan Observatory	China	yoysx@public.km.yn.cn
Dr. A. Zhestkov	IMVP VNIIFTRI	Russia	mark@imvp.aspnet.ru
Zhang Zhongping	Shanghai Data Center	China	zzp@center.shao.ac.cn
Wei Zibin	Beijing Station	China	wangtq@sun.ihep.ac.cn
Michail Zinkovsky	Russian Mission Control Centre	Russia	bulmon@podlipki.ru

ILRS CORRESPONDENTS

Name	Organization	Country	E-Mail
Dr. Richard Biancale	CNES/GRGS	France	richard.biancale@cnes.fr
Patrick Ferrick	Town of Webb School	United States	ferrick@zebulon.telenet.net
Dr. Richard S. Gross	JPL/Mail Stop 238-332	United States	rsg@logos.jpl.nasa.gov
Dr. Karel Hamal	Tech U. Prague/Dept. of Phys. Electronics	Czech Republic	hamal@troja.fjfi.cvut.cz
Dr. John LaBrecque	NASA HQ	United States	jlabrecq@hq.nasa.gov
Gene H. McCall	Peterson AFB, HQ AFSPC/CN	United States	gene.mccall@peterson.af.mil
Dr. George Nicolson	Hartebeesthoek Radio Astronomy Observatory	South Africa	george@bootes.hartrao.ac.za
Konstantin Nurutdinov	Department of Geomatics	United Kingdom	konstantin.nurutdinov@ncl.ac.uk
Dr. Ivan Prochazka	Technical University of Prague	Czech Republic	prochazk@troja.fjfi.cvut.cz
John W. Robbins	Pope John XXIII National Seminary	United States	jrobbins@ziplink.net
Jim Slater	NIMA, GICS	United States	slaterj@nima.mil

8.9 LIST OF ACRONYMS

AAC	Associate Analysis Center
AASTR	Advanced Along Track Scanning Radiometer
AC	Analysis Center
ACT	Australian Capital Territory
ADEOS	Advanced Earth Observing Satellite
AFSPC	Air Force Space Command (USA)
AGU	American Geophysical Union
AIUB	Astronomical Institute of Berne (Switzerland)
APD	Avalanche Photo Diode
APRGP	Asia-Pacific Regional Geodetic Project
APSG	Asia-Pacific Space Geodynamics Project
ASAR	Advanced Synthetic Aperture Radar
ASCII	American Standard Code for Information Interchange
ASI	Agenzia Spaziale Italiana (Italian Space Agency)
ATSC	AlliedSignal Technical Services Corporation (USA)
AUSLIG	Australian Surveying and Land Information Group
AWG	Analysis Working Group
Az/EI	Azimuth/Elevation
BAE	British Aerospace (Australia)
BE-C	Beacon Explorer C
BFEC	Bendix Field Engineering Corporation (USA)
BIPM	Bureau International des Poids et Mesures (France)
BKG	Bundesamt für Kartographie und Geodäsie (Germany)
CB	Central Bureau
CCD	Charged Coupled Device
CDDIS	Crustal Dynamics Data Information System (USA)
CDP	Crustal Dynamics Project
CERGA	Centre d'Etudes et de Recherches Géodynamiques et Astrométrie (France)
CF	Constant Fraction
CfA	Center for Astrophysics (USA)
CGS	Centro de Geodesia Spaziale (Italy)
CHAMP	CHALLENGING Mini-Satellite Payload
CIS	Conventional Inertial System
CMONOC	Crustal Movement Observation Network of China
CNES	Centre National d'Etudes Spatiales (France)
CNS	Communication, Navigation, Surveillance (USA)
CODE	Center for Orbit Determination in Europe
COM	Center Of Mass
CONAE	Comisión Nacional de Actividades Espaciales (Argentina)
CPU	Central Processing Unit
CRL	Communications Research Laboratory (Japan)
C-SPAD	Compensated Single Photoelectron Avalanche Detector
CSR	Center for Space Research (USA)
CSTG	International Coordination of Space Techniques for Geodesy and Geodynamics

CTLRs	Chinese Transportable Laser Ranging System
CTU FNSPE	Czech Technical University Faculty of Nuclear Science and Physical Engineering
DEC	Digital Equipment Corporation
DEOS	Delft Institute for Earth-Oriented Space Research (The Netherlands)
DFPWG	Data Formats and Procedures Working Group
DGFI	Deutsches Geodätisches Forschungsinstitut (Germany)
DGPS	Differential GPS
DMS	Data Measurement System
DOGS	DGFI Orbit and Geodetic Parameter Estimation System (Germany)
DOMES	Directory Of MERIT Sites
DORIS	Doppler Orbitography and Radiopositioning Integrated by Satellite
D-PAF	Germany Processing and Analysis Facility
DUT	Delft University of Technology (The Netherlands)
EDC	EUROLAS Data Center (Germany)
EGS	European Geophysical Society
ELV	Expendable Launch Vehicle
ENVISAT	ENVironmental SATellite
EOP	Earth Orientation Parameter
EOS	Electro Optical Systems (Australia)
EOS	European Optical Society
ERA	Ephemeris Research in Astronomy (Russia)
ERS	European Remote Sensing Satellite
ESA	European Space Agency
ESOC	ESA Space Operations Center (Germany)
ESRIN	European Space Research Institute
ETS	Engineering Test Satellite
EUROLAS	European Laser Consortium
FAQ	Frequently Asked Question
FDR	Foundation for Research Development (South Africa)
FESG	Forschungseinrichtung Satellitengeodäsie (Research Facility for Space Geodesy, Germany)
FFI	Forsvarets Forskningsinstitutt (Norwegian Defense Research Establishment)
FR	Full Rate
FTLRs	French Transportable Laser Ranging System
FTP	File Transfer Protocol
GAOUA	Main Astronomical Observatory of the National Academy of Sciences of Ukraine
GB	Gigabyte
GB	Governing Board
GDR	Geophysical Data Record
GeoDAF	Geodetical Data Archive Facility (Italy)
GeodIS	Geodetic Information System (Germany)
GEOS	Geodetic and Earth Orbiting Satellite
GEOSAT	Geodesy Satellite
GFO	GEOSAT Follow-On (USA)
GFZ	GeoForschungsZentrum (Germany)
GGAO	Goddard Geophysical and Astronomical Observatory (USA)
GIS	Geographic Information System
GLAS	Geoscience Laser Altimeter System
GLONASS	Global Navigation Satellite System

GLONASS	Global'naya Navigatsionnay Sputnikovaya Sistema
GM	Gravity Model
GOMOS	Global Ozone Monitoring by Occultation of Stars
GOSSTANDART	Russian Agency for Standardization
GP-B	Gravity Probe B
GPS	Global Positioning System
GRACE	Gravity Recovery And Climate Experiment
GRGS	Groupe de Recherches de Géodésie Spatiale (France)
GROSS	Geodynamics, Rotation of the Earth, Orbit determination Searching Software (Russia)
GSFC	Goddard Space Flight Center (USA)
HOLLAS	Haleakala Laser Station (USA)
HTSI	Honeywell Technology Solutions, Inc. (USA)
H/W	Hardware
IAA	Institute of Applied Astronomy, Russia
IAG	International Association of Geodesy
IAPG	Institut für Astronomische und Physikalische Geodäsie (Germany)
IAU	International Astronomical Union
ICESat	Ice Cloud and Land Elevation Satellite
ICRF	International Celestial Reference Frame
ICRS	International Celestial Reference System
IERS	International Earth Rotation Service
IGEX	International GLONASS EXperiment
IGN	Institut Geographique National (France)
IGS	International GPS Service for Geodynamics
ILRS	International Laser Ranging Service
IMVP	Institute of Metrology for Time and Space (Russia)
INASAN	Institute of Astronomy of the Russian Academy of Sciences
ION	Institute of Navigation
IPIE	Institute for Precision Instrument Engineering (Russia)
IRS	Indian Remote Sensing Satellite
IRV	Inter-Range Vector
ISRO	Indian Space Research Organization
ISTRAC	ISRO Telemetry Tracking and Command Network (India)
ITRF	International Terrestrial Reference Frame
ITRS	International Terrestrial Reference System
ITSM	Institute for Time and Space Metrology (Russia)
ITSS	Raytheon Information Technology and Scientific Services (USA)
IUGG	International Union of Geodesy and Geophysics
IVS	International VLBI Service for Geodesy and Astrometry
JCET	Joint Center for Earth Systems Technology (USA)v
JGM	Joint Gravity Model
JGR	Journal of Geophysical Research
JHD	Japanese Hydrographic Department
JPL	Jet Propulsion Laboratory (USA)
KACST	King Abdulaziz City for Science and Technology (Saudi Arabia)
LAGEOS	LAser GEOdynamics Satellite
LAN	Local Area Network

LEO	Low Earth Orbit
LIDAR	Light Detection and Ranging
LLR	Lunar Laser Ranging
LOD	Length Of Day
LPSC	Lunar and Planetary Science Conference
LRA	Laser Retroreflector Array
L+T	Swiss Federal Office of Topography
LURE	LUnar Ranging Experiment
MAO	Main Astronomical Observatory (Ukraine)
MCC	Mission Control Center (Russia)
MCEP	Mean Celestial Ephemeris Pole
MCP	Micro Channel Plate
MEDLAS	Mediterranean Laser Campaign
MEO	Medium Earth Orbit
MERIS	MEDium Resolution Imaging Spectrometer
MERIT	Monitoring of Earth Rotation and Intercomparison of Techniques
MIPAS	Michelson Interferometer for Passive Atmospheric Sounding
MIT	Massachusetts Institute of Technology (USA)
MLRO	Matera Laser Ranging Observatory (Italy)
MLRS	McDonald Laser Ranging System (USA)
MOBLAS	MOBile LASer Ranging System
MOM	Mobile Optical Mount
MTLRS	Modular Transportable Laser Ranging System
MWG	Missions Working Group
MWV	MicroWave Radiometer
NASA	National Aeronautics and Space Administration (USA)
NASDA	National Space Development Agency (Japan)
NAVNET	Navy VLBI Network
NCL	University of Newcastle Upon Tyne (United Kingdom)
NERC	Natural Environment Research Council (United Kingdom)
NEWG	Networks and Engineering Working Group
Nd: YAG	Neodymium Yttrium Aluminum Garnet
NP	Normal Point
NRIAG	National Research Institute of Astronomy and Geophysics (Egypt)
OAC	Operational Analytic Center
OCA	Observatoire de la Côte d'Azur (France)
OMC	Observed Minus Computed
ONP	On-site Normal Point
OSC	Orbital Sciences Corporation (USA)
PAS	Polish Academy of Sciences
PC	Personal Computer
PCGIAP	Permanent Committee for GIS Infrastructure for Asia and the Pacific
PDF	Portable Document Format
PDF	Probability Density Function
PEP	Planetary Ephemeris Program
PM	Polar Motion
PMT	Photo Multiplier Tube
PM/UT	Polar Motion/Universal Time
POD	Precise Orbit Determination

POLAC	Paris Observatory Lunar Analysis Center (France)
PRARE	Precise Range and Range-rate Equipment
PRC	People's Republic of China
PRN	Pseudo Random Noise
QC	Quality Control
QL	Quick-Look
QLDAC	Quick-Look Data Analysis Center (The Netherlands)
QMCP	Quadrant Microchannel Plate
RA	Radar Altimeter
RAM	Random Access Memory
RISDE	Russian Institute of Space Device Engineering
RITSS	Raytheon Information Technology and Scientific Services (USA)
RMS	Root Mean Square
ROSAVIKOSMOS	Russian Aerospace Agency
RRA	RetroReflector Array
RSA	Russian Space Agency
SAC	Astronomical Station of Cagliari (Italy)
SALRO	Saudi Arabian Laser Ranging Observatory (Saudi Arabia)
SAO	Smithsonian Astrophysical Observatory (USA)
SAR	Synthetic Aperture Radar
SCIAMACHY	SCanning Imaging Absorption spectrometer for AtMospheric Cartography
SENH	Solid Earth and Natural Hazards
SGF	Space Geodesy Facility (United Kingdom)
SGP	Space Geodesy Program
SI	International System of Units
SINEX	Software Independent Exchange Format
SLR	Satellite Laser Ranging
SNR	Signal to Noise Ratio
SOD	Site Occupation Designator
SP	Signal Processing
SPAD	Single Photoelectron Avalanche Detector
SPIE	International Society for Optical Engineering
SPWG	Signal Processing Working Group
SRDC	Shanghai Regional Data Center (China)
SRI	Space Research Institute (Russia)
SRP	System Reference Point
SSC	Set of Station Coordinates
SSV	Set of Station Velocities
STALAS	Stationary Laser Station
SUNSAT	Stellenbosch UNiversity SATellite (South Africa)
S/W	Software
TAC	Totally Accurate Clock
TB	TerraByte
TCP/IP	Transmission Control Protocol/INTERnet Protocol
TIGO	Transportable Integrated Geodetic Observatory
TLRS	Transportable Laser Ranging System
TOPEX	Ocean TOPography Experiment
T/P	TOPEX/Poseidon

T/R	Transfer/Receive
TRF	Terrestrial Reference Frame
TTandC	Tracking-Telemetry/Control
TUM	Technical University of Munich (Germany)
UK	United Kingdom
UMBC	University of Maryland Baltimore County (USA)
UPF	Université de la Polynésie Française (French Polynesia)
URL	Uniform Resource Locator
USA	United States of America
USNO	United States Naval Observatory
UT	Universal Time
UT	University of Texas (USA)
UTC	Universal Coordinated Time
UTOPIA	University of Texas Orbit Processor (USA)
UTXM	University of Texas McDonald Observatory Lunar Analysis Center
VCL	Vegetation Canopy Lidar
VLBI	Very Long Baseline Interferometry
VNIIFTRI	All-Russian Scientific Research Institute for Physical-Technical and Radiotechnical Measurements (Russia)
VOL	Variation Of Latitude
WEGENER	Working Group of European Geoscientists for the Establishment of Networks for Earthquake Research
WESTPAC	Western Pacific Laser Tracking Network Satellite
WG	Working Group
WLRS	Wetzell Laser Ranging System (Germany)
WPLTN	Western Pacific Laser Tracking Network
WRMS	Weighted Root Mean Square
WWW	World Wide Web
Y2K	Year 2000



REPORT DOCUMENTATION PAGE

Form Approved
OMB No. 0704-0188

Public reporting burden for this collection of information is estimated to average 1 hour per response, including the time for reviewing instructions, searching existing data sources, gathering and maintaining the data needed, and completing and reviewing the collection of information. Send comments regarding this burden estimate or any other aspect of this collection of information, including suggestions for reducing this burden, to Washington Headquarters Services, Directorate for Information Operations and Reports, 1215 Jefferson Davis Highway, Suite 1204, Arlington, VA 22202-4302, and to the Office of Management and Budget, Paperwork Reduction Project (0704-0188), Washington, DC 20503.

1. AGENCY USE ONLY (Leave blank)		2. REPORT DATE December 2000	3. REPORT TYPE AND DATES COVERED Technical Publication	
4. TITLE AND SUBTITLE International Laser Ranging Service (ILRS) 1999 Annual Report			5. FUNDING NUMBERS Code 920.1	
6. AUTHOR(S) Edited by: Michael Pearlman and Linda Taggart				
7. PERFORMING ORGANIZATION NAME(S) AND ADDRESS (ES) Geoscience Technology Office Goddard Space Flight Center Greenbelt, Maryland 20771			8. PERFORMING ORGANIZATION REPORT NUMBER 2001-00222-0	
9. SPONSORING / MONITORING AGENCY NAME(S) AND ADDRESS (ES) National Aeronautics and Space Administration Washington, DC 20546-0001			10. SPONSORING / MONITORING AGENCY REPORT NUMBER TP-2000-209969	
11. SUPPLEMENTARY NOTES M.Pearlman: Harvard-Smithsonian Center for Astrophysics; L. Taggart: Raytheon ITSS Work performed in support of ILRS Central Bureau within NASA/GSFC, Code 920.1.				
12a. DISTRIBUTION / AVAILABILITY STATEMENT Unclassified-Unlimited Subject Category: 46 Report available from the NASA Center for AeroSpace Information, 7121 Standard Drive, Hanover, MD 21076-1320. (301) 621-0390.			12b. DISTRIBUTION CODE	
13. ABSTRACT (Maximum 200 words) This 1999 Annual Report of the International Laser Ranging Service (ILRS) is comprised of individual contributions from ILRS components within the international geodetic community. This report documents the work of the ILRS components from the inception of the Service through December 31, 1999. Since the Service has only recently been established, the ILRS associates decided to publish this Annual Report as a reference to our organization and its components.				
14. SUBJECT TERMS Laser Ranging, Space Geodesy, Geophysics, Geodynamics, ILRS			15. NUMBER OF PAGES 285	
			16. PRICE CODE	
17. SECURITY CLASSIFICATION OF REPORT Unclassified	18. SECURITY CLASSIFICATION OF THIS PAGE Unclassified	19. SECURITY CLASSIFICATION OF ABSTRACT Unclassified	20. LIMITATION OF ABSTRACT UL	