



# An OFDM System Using Polyphase Filter and DFT Architecture for Very High Data Rate Applications

Muli Kifle and Monty Andro  
Glenn Research Center, Cleveland, Ohio

Mark J. Vanderaar  
Efficient Channel Coding, Inc., Brooklyn Heights, Ohio

## The NASA STI Program Office . . . in Profile

Since its founding, NASA has been dedicated to the advancement of aeronautics and space science. The NASA Scientific and Technical Information (STI) Program Office plays a key part in helping NASA maintain this important role.

The NASA STI Program Office is operated by Langley Research Center, the Lead Center for NASA's scientific and technical information. The NASA STI Program Office provides access to the NASA STI Database, the largest collection of aeronautical and space science STI in the world. The Program Office is also NASA's institutional mechanism for disseminating the results of its research and development activities. These results are published by NASA in the NASA STI Report Series, which includes the following report types:

- **TECHNICAL PUBLICATION.** Reports of completed research or a major significant phase of research that present the results of NASA programs and include extensive data or theoretical analysis. Includes compilations of significant scientific and technical data and information deemed to be of continuing reference value. NASA's counterpart of peer-reviewed formal professional papers but has less stringent limitations on manuscript length and extent of graphic presentations.
- **TECHNICAL MEMORANDUM.** Scientific and technical findings that are preliminary or of specialized interest, e.g., quick release reports, working papers, and bibliographies that contain minimal annotation. Does not contain extensive analysis.
- **CONTRACTOR REPORT.** Scientific and technical findings by NASA-sponsored contractors and grantees.

- **CONFERENCE PUBLICATION.** Collected papers from scientific and technical conferences, symposia, seminars, or other meetings sponsored or cosponsored by NASA.
- **SPECIAL PUBLICATION.** Scientific, technical, or historical information from NASA programs, projects, and missions, often concerned with subjects having substantial public interest.
- **TECHNICAL TRANSLATION.** English-language translations of foreign scientific and technical material pertinent to NASA's mission.

Specialized services that complement the STI Program Office's diverse offerings include creating custom thesauri, building customized data bases, organizing and publishing research results . . . even providing videos.

For more information about the NASA STI Program Office, see the following:

- Access the NASA STI Program Home Page at <http://www.sti.nasa.gov>
- E-mail your question via the Internet to [help@sti.nasa.gov](mailto:help@sti.nasa.gov)
- Fax your question to the NASA Access Help Desk at 301-621-0134
- Telephone the NASA Access Help Desk at 301-621-0390
- Write to:  
NASA Access Help Desk  
NASA Center for AeroSpace Information  
7121 Standard Drive  
Hanover, MD 21076

NASA/TM—2001-210813



# An OFDM System Using Polyphase Filter and DFT Architecture for Very High Data Rate Applications

Muli Kifle and Monty Andro  
Glenn Research Center, Cleveland, Ohio

Mark J. Vanderaar  
Efficient Channel Coding, Inc., Brooklyn Heights, Ohio

Prepared for the  
19th International Communications Satellite Systems Conference and Exhibit  
cosponsored by the AIAA, CNES, ESA, and SUPAERO  
Toulouse, France, April 17–20, 2001

National Aeronautics and  
Space Administration

Glenn Research Center

---

May 2001

Available from

NASA Center for Aerospace Information  
7121 Standard Drive  
Hanover, MD 21076

National Technical Information Service  
5285 Port Royal Road  
Springfield, VA 22100

Available electronically at <http://gltrs.grc.nasa.gov/GLTRS>

# AN OFDM SYSTEM USING POLYPHASE FILTER AND DFT ARCHITECTURE FOR VERY HIGH DATA RATE APPLICATIONS

Muli Kifle

NASA Glenn Research Center, MS 54-8  
Cleveland, OH 44135 USA  
Tel. 216-433-6521 Fax 216-433-8705  
Muli.Kifle@grc.nasa.gov

Monty Andro

NASA Glenn Research Center, MS 54-8  
Cleveland, OH 44135 USA  
Tel. 216-433-3492 Fax 216-433-8705  
Monty.Andro@grc.nasa.gov

Mark J. Vanderaar

Efficient Channel Coding, Inc  
Brooklyn Heights, OH 44131 USA  
Tel. 216.514.9516 Fax 216.514.9519  
info@eccincorp.com

## **Abstract**

This paper presents a conceptual architectural design of a four-channel Orthogonal Frequency Division Multiplexing (OFDM) system with an aggregate information throughput of 622 megabits per second (Mbps). Primary emphasis is placed on the generation and detection of the composite waveform using polyphase filter and Discrete Fourier Transform (DFT) approaches to digitally stack and bandlimit the individual carriers. The four-channel approach enables the implementation of a system that can be both power and bandwidth efficient, yet enough parallelism exists to meet higher data rate goals. It also enables a DC power efficient transmitter that is suitable for on-board satellite systems, and a moderately complex receiver that is suitable for low-cost ground terminals. The major advantage of the system as compared to a single channel system is lower complexity and DC power consumption. This is because the highest sample rate is  $\frac{1}{2}$  that of the single channel system and synchronization can occur at most, depending on the synchronization technique,  $\frac{1}{4}$  the rate of a single channel system. The major disadvantage is the increased peak-to-average power ratio over the single channel system. Simulation results in a form of bit-error-rate (BER) curves are presented in this paper.

## **Introduction**

A number of proposed broadband satellite communications systems feature rates at or in excess of 622 Mbps per downlink with spectrum allocations generally being less than 500 MHz. This requires the application of bandwidth and power efficient transmission techniques. Number of approaches to implementing such techniques includes analog, digital, mixed signal systems, single channel, or multi-channel. In general, the digital implementations offer more advantages. However, fully digital implementation at data rates in excess of 622 Mbps is difficult due to the high clock speeds that are required. For example, an uncoded 16-ary Quadrature Amplitude Modulation (16QAM) system requires a symbol rate of about 156 Msymbols/sec to attain a

throughput of 622 Mbps. If four samples per symbol are used to generate and reconstruct the waveform, the sample rate is 622 Msamples/sec.

In this paper, we examine the use of multichannel techniques as another way of reducing the sample rate. One such technique, Multi-Carrier Modulation (MCM) [7], divides the data into a number of low rate channels that are stacked in frequency and separated by 1/symbol rate. MCM, sometimes also called OFDM, is being proposed for numerous systems including mobile wireless and digital subscriber link systems.

### OFDM System Overview

The basic OFDM waveform in this paper is constructed by dividing an incoming data stream into  $N=4$  channels, each channel using Offset-16QAM. Each input channel symbol is denoted  $x_i$ ,  $i=0,1,2,7$  and is actually a complex number that is written as

$$x_i = a_i + jb_i, i = 0,1,2,7$$

The reason the fourth channel is labeled 7 will become clear in the discrete time system. The time domain waveform of each Offset-16QAM channel is thus written as

$$x_i(t) = a_i(t) + jb_i(t - T/2), i = 0,1,2,7 \quad \text{where } T \text{ is the symbol rate. Each complex channel is then filtered to limit the bandwidth of each channel.}$$

This is written as

$$x_i(t) * h(t) \quad \text{where } h(t) \text{ is the filter function and the } * \text{ denotes convolution.}$$

Each complex channel is then stacked in frequency with carriers that are separated in frequency by  $1/T$  and are separated in phase by  $\pi/2$ . The complex carriers can thus be written as

$$c_i(t) = \exp\left(j\left(\frac{2\pi}{T}t + \frac{\pi}{2}\right)i\right), i = 0,1,2,7$$

Each channel's modulated waveform is then

$$m_i(t) = (x_i(t) * h(t))c_i(t), i = 0,1,2,7 \quad \text{and the overall transmitted waveform is the summation of all channels.}$$

$$m(t) = \sum_{i=0,1,2,7} m_i(t) = \sum_{i=0,1,2,7} ((a_i(t) + jb_i(t)) * h(t)) \exp\left(j\left(\frac{2\pi}{T}t + \frac{\pi}{2}\right)i\right)$$

Pictorially, assuming a spectral shape for  $h(t)$ , the frequency response of the composite waveform is shown below.

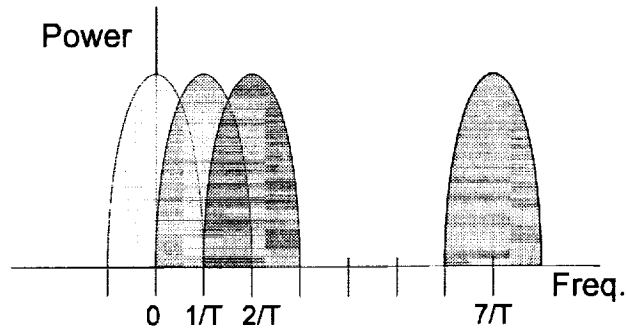

At the receiver side the composite waveform is split into four channels that are each down converted by

$$(c_i(t))^{-1} = \exp\left(-j\left(\frac{2\pi}{T}t + \frac{\pi}{2}\right)i\right), i = 0,1,2,7$$

Each baseband waveform is then passed through the matched filtered to  $h(t)$ , denoted  $g(t)$ . The matched filtered data is an estimate of the transmitted data and is denoted

$$\hat{x}_i(t) = \hat{a}_i(t) + j\hat{b}_i(t - T/2), i = 0,1,2,7$$

The structure is illustrated below.

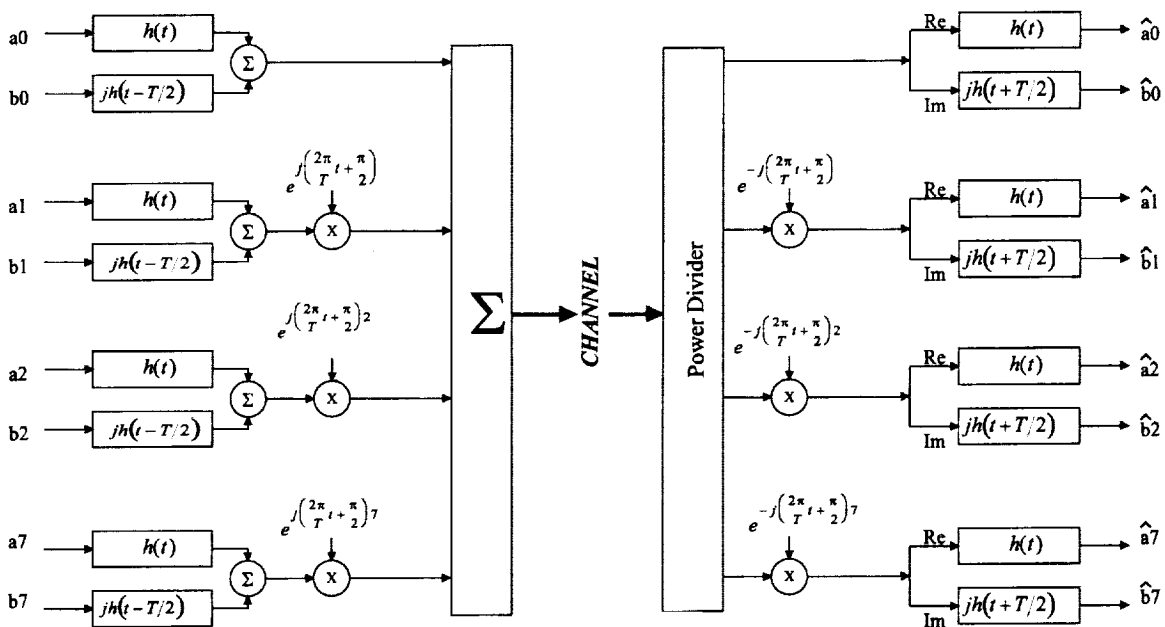

The conditions for zero intersymbol interference (ISI) and interchannel interference (ICI) as related to the filters  $h(t)$  and  $g(t)$  are derived in [8]. They are written as

$$\begin{aligned} \left[ \operatorname{Re} \left\{ h(t - kT) \exp \left( j \left( \frac{2\pi}{T} t + \frac{\pi}{2} \right) i \right) * g(t) \right\} \right]_{t=0} &= \delta(i, k) \\ \left[ \operatorname{Re} \left\{ j h(t - kT - \frac{T}{2}) \exp \left( j \left( \frac{2\pi}{T} t + \frac{\pi}{2} \right) i \right) * g(t) \right\} \right]_{t=0} &= 0 \\ \left[ \operatorname{Im} \left\{ h(t - kT) \exp \left( j \left( \frac{2\pi}{T} t + \frac{\pi}{2} \right) i \right) * g(t + \frac{T}{2}) \right\} \right]_{t=0} &= 0 \\ \left[ \operatorname{Im} \left\{ h(t - kT - \frac{T}{2}) \exp \left( j \left( \frac{2\pi}{T} t + \frac{\pi}{2} \right) i \right) * g(t + \frac{T}{2}) \right\} \right]_{t=0} &= \delta(i, k) \end{aligned}$$

where  $k$  is a value that defines a single instant within a symbol in which the zero ISI and ICI conditions hold.  $\delta(i, k)$  is the 2-D Kronecker delta function, written as

$$\delta(i, k) = \begin{cases} 1, & i = k = 0 \\ 0, & \text{otherwise} \end{cases}$$

It is well known that an efficient implementation of this type of architecture can be achieved using the combination of a DFT and Inverse DFT (IDFT) at the receiver to perform the frequency translation and a polyphase filter to facilitate the pulse shaping. In the four-channel system, a 4-point complex DFT is required to accommodate the four Offset-16QAM channels. However, without considering the use of interpolating filters to increase the sample rate, the practical size is the 8-point complex DFT, which allows the rejection of aliases, when converting the signal to the analog domain. The discrete time version of the modulated waveform can be written as

$$x[n] = x_i(nT_s) = a_i(nT_s) + j b_i(nT_s - T/2), \quad i = 0, 1, 2, 7 \quad \text{where } T_s \text{ is the sample time and } n \text{ is the sample number.}$$

If  $T_s$  is set to  $1/8$  of the symbol time, the equation becomes

$$x_i[n] = x_i(nT_s) = a_i(nT_s) + j b_i(nT_s - 4T_s), \quad i = 0, 1, 2, 7$$

Similarly, the convolution with the filter can be expanded to

$$s_i[n] = s_i(nT_s) = x_i(nT_s) * h(nT_s) = \sum_{\tau=0}^{l-1} x(\tau) h(nT_s - \tau) =$$

$$\sum_{\tau=0}^{l-1} [a_i(\tau) + j b_i(\tau - 4T_s)] h(nT_s - \tau), \quad i = 0, 1, 2, 7$$

and

$$s[n] = s(nT_s) = \sum_{i=0,1,2,7} s_i[n] = \sum_{i=0,1,2,7} \left[ \sum_{\tau=0}^{l-1} [a_i(\tau) + j b_i(\tau - 4T_s)] h(nT_s - \tau) \right]$$

Thus, the transmitted signal is



$$m[n]=m(nT_s) = \sum_{i=0,1,2,7} s_i[n] \exp\left(j\left(\frac{\pi}{4}n + \frac{\pi}{2}\right)i\right) = \sum_{i=0,1,2,7} s_i[n] \exp\left(j\frac{\pi}{4}ni\right) \exp\left(j\frac{\pi}{2}i\right)$$

In general, the 8-point complex DFT of a signal is written as

$$\Phi_k = \sum_{i=0}^7 \phi_i \exp(j\frac{\pi}{4}ki), k = 0,1,2\dots7$$

Thus if we set  $\phi_i = s_i[n] \exp(j\frac{\pi}{2}i), i = 0,1,2\dots7$

We have  $m[n] = \Phi_k$

and thus the waveform can be generated using an 8-point complex DFT. That is, each eight complex inputs ( $s_i[n]=0$  for  $i= 3, 4, 5, 6$ ) will generate 8 complex outputs. These outputs are then multiplexed in time to obtain the waveform  $m[n]$ . Switching real and imaginary components, and negating if necessary can accommodate the  $\pi / 2$  phase shifts.

This direct implementation requires filtering each channel at the sample rate and performing the DFT at the sample rate. It is also well known that the amount of computations can be greatly reduced by moving the filter function after the DFT and distributing it among the channels. In most systems this results in an N point complex DFT running at the symbol rate and N polyphase filters with L/N taps each running at the symbol rate (L is the total number of taps). However, in our system we use Offset-16QAM to maintain the orthogonal nature of each channel. Imparting one half- symbol delay into the filters on the imaginary channels facilitates this. This one half symbol delay precludes the movement of the filters to after the DFT. To circumvent this difficulty two DFTs are used. The first DFT processes the real components of the four channels (with the appropriate  $\pi / 2$  phase shifts) and the second DFT processes the imaginary components (with the appropriate  $\pi / 2$  phase shifts). The results of each DFT are sent through their appropriate polyphase filters and multiplexed. Finally, the multiplexed imaginary results are delayed by four samples (one half of a symbol) and added to the multiplexed real results. A similar operation occurs at the receiver. In the next two sections, we show that this structure offers the potential for complexity reduction at both the transmitter and receiver, making it suitable for high-speed implementation.

### **Modulation and DFT Approach**

The amplitude structure in 16QAM can be used to reduce the complexity of transmit pulse shaping filters. Similar principles are applied to the DFT and polyphase filters. First, each unique In-phase (I) and Quadrature (Q) modulation level is assigned a 2-bit label representing each of the 4 possible amplitude levels in a 16QAM constellation. A 16QAM constellation with amplitude levels

$$\text{Re}\{x_i[n]\} = a_i[n] \in \{-3.0, -1.0, 1.0, 3.0\}, i = 0,1,2,7$$

$$j \text{Im}\{x_i[n]\} = jb_i[n] \in \{-3.0j, -1.0j, 1.0j, 3.0j\}, i = 0,1,2,7$$

can be represented as two bit labels as

$$A_i[n] \in \{00, 01, 10, 11\}, i = 0,1,2,7$$

$$B_i[n] \in \{00, 01, 10, 11\}, i = 0,1,2,7$$

where  $A_i[n]$  is the label for the I value and  $B_i[n]$  is the label for the Q value. Labels from four channels ( $i=0,1,2,7$ ) can be used to form an 8-tuple that represent all possible inputs to the real-input DFT. Similarly, an 8-tuple is generated to represent all possible inputs to the imaginary-input DFT. Recall also that the input to the DFT needs to be rotated by a multiple of  $\pi/2$  to maintain orthogonality. That is

$$a_i[n] \exp\left(j \frac{\pi}{2} i\right) \in \{-3.0, -1.0, 1.0, 3.0\} \exp\left(j \frac{\pi}{2} i\right) i = 0,1,2,7$$

$$j b_i[n] \exp\left(j \frac{\pi}{2} i\right) \in \{-3.0j, -1.0j, 1.0j, 3.0j\} \exp\left(j \frac{\pi}{2} i\right) i = 0,1,2,7$$

Thus the labels for the different channels actually represent different amplitude values. The 8-tuples are formed as a concatenation of their 2 bit labels as follows

$$\bar{A}[n] \equiv A_0[n]A_1[n]A_2[n]A_7[n] \in \{00000000, 00000001, 00000010, \dots, 11111111\}$$

$$\bar{B}[n] \equiv B_0[n]B_1[n]B_2[n]B_7[n] \in \{00000000, 00000001, 00000010, \dots, 11111111\}$$

In our design, we use 4 of the modulation channels. Only needing 2 bits to describe each channel's in phase or quadrature data, we can use 8-bit blocks of data for processing Q and I separately. This knowledge of the data to be transmitted is the base for the design of the digital transmitter.

### **Transmit DFT Design**

An N point DFT is written as

$$X(k) = \sum_{n=0}^{N-1} x(n) W_N^{kn}, k = 0,1,2 \dots N-1$$

$$\text{where } W_N^{kn} = \exp\left(-j \frac{2\pi}{N} kn\right)$$

If  $N=8$ , then

$$X(k) = \sum_{n=0}^7 x(n) W_8^{kn}, k = 0,1,2 \dots 7$$

which can be written in matrix form

$$X(k) = \begin{bmatrix} 1 & 1 & 1 & 1 & 1 & 1 & 1 & 1 \\ 1 & e^{-j\frac{\pi}{4}} & e^{-j\frac{2\pi}{4}} & e^{-j\frac{3\pi}{4}} & e^{-j\frac{4\pi}{4}} & e^{-j\frac{5\pi}{4}} & e^{-j\frac{6\pi}{4}} & e^{-j\frac{7\pi}{4}} \\ 1 & e^{-j\frac{2\pi}{4}} & e^{-j\frac{4\pi}{4}} & e^{-j\frac{6\pi}{4}} & e^{-j\frac{8\pi}{4}} & e^{-j\frac{10\pi}{4}} & e^{-j\frac{12\pi}{4}} & e^{-j\frac{14\pi}{4}} \\ 1 & e^{-j\frac{3\pi}{4}} & e^{-j\frac{6\pi}{4}} & e^{-j\frac{9\pi}{4}} & e^{-j\frac{12\pi}{4}} & e^{-j\frac{15\pi}{4}} & e^{-j\frac{18\pi}{4}} & e^{-j\frac{21\pi}{4}} \\ 1 & e^{-j\frac{4\pi}{4}} & e^{-j\frac{8\pi}{4}} & e^{-j\frac{12\pi}{4}} & e^{-j\frac{16\pi}{4}} & e^{-j\frac{20\pi}{4}} & e^{-j\frac{24\pi}{4}} & e^{-j\frac{28\pi}{4}} \\ 1 & e^{-j\frac{5\pi}{4}} & e^{-j\frac{10\pi}{4}} & e^{-j\frac{15\pi}{4}} & e^{-j\frac{20\pi}{4}} & e^{-j\frac{25\pi}{4}} & e^{-j\frac{30\pi}{4}} & e^{-j\frac{35\pi}{4}} \\ 1 & e^{-j\frac{6\pi}{4}} & e^{-j\frac{12\pi}{4}} & e^{-j\frac{18\pi}{4}} & e^{-j\frac{24\pi}{4}} & e^{-j\frac{30\pi}{4}} & e^{-j\frac{36\pi}{4}} & e^{-j\frac{42\pi}{4}} \\ 1 & e^{-j\frac{7\pi}{4}} & e^{-j\frac{14\pi}{4}} & e^{-j\frac{21\pi}{4}} & e^{-j\frac{28\pi}{4}} & e^{-j\frac{35\pi}{4}} & e^{-j\frac{42\pi}{4}} & e^{-j\frac{49\pi}{4}} \end{bmatrix} \begin{bmatrix} x(0) \\ x(1) \\ x(2) \\ x(3) \\ x(4) \\ x(5) \\ x(6) \\ x(7) \end{bmatrix}$$

Since the four-channel architecture only uses channels 0,1,2, and 7, this equation reduces to

$$X(k) = \begin{bmatrix} 1 & 1 & 1 & 1 \\ 1 & e^{-j\frac{\pi}{4}} & e^{-j\frac{2\pi}{4}} & e^{-j\frac{7\pi}{4}} \\ 1 & e^{-j\frac{2\pi}{4}} & e^{-j\frac{4\pi}{4}} & e^{-j\frac{14\pi}{4}} \\ 1 & e^{-j\frac{3\pi}{4}} & e^{-j\frac{6\pi}{4}} & e^{-j\frac{21\pi}{4}} \\ 1 & e^{-j\frac{4\pi}{4}} & e^{-j\frac{8\pi}{4}} & e^{-j\frac{28\pi}{4}} \\ 1 & e^{-j\frac{5\pi}{4}} & e^{-j\frac{10\pi}{4}} & e^{-j\frac{35\pi}{4}} \\ 1 & e^{-j\frac{6\pi}{4}} & e^{-j\frac{12\pi}{4}} & e^{-j\frac{42\pi}{4}} \\ 1 & e^{-j\frac{7\pi}{4}} & e^{-j\frac{14\pi}{4}} & e^{-j\frac{49\pi}{4}} \end{bmatrix} \begin{bmatrix} x(0) \\ x(1) \\ x(2) \\ x(7) \end{bmatrix}$$

However, each one of the  $x(n)$  values is a complex number, thus

$$X(k) = \begin{bmatrix} 1 & 1 & 1 & 1 \\ 1 & e^{-j\frac{\pi}{4}} & e^{-j\frac{2\pi}{4}} & e^{-j\frac{7\pi}{4}} \\ 1 & e^{-j\frac{2\pi}{4}} & e^{-j\frac{4\pi}{4}} & e^{-j\frac{14\pi}{4}} \\ 1 & e^{-j\frac{3\pi}{4}} & e^{-j\frac{6\pi}{4}} & e^{-j\frac{21\pi}{4}} \\ 1 & e^{-j\frac{4\pi}{4}} & e^{-j\frac{8\pi}{4}} & e^{-j\frac{28\pi}{4}} \\ 1 & e^{-j\frac{5\pi}{4}} & e^{-j\frac{10\pi}{4}} & e^{-j\frac{35\pi}{4}} \\ 1 & e^{-j\frac{6\pi}{4}} & e^{-j\frac{12\pi}{4}} & e^{-j\frac{42\pi}{4}} \\ 1 & e^{-j\frac{7\pi}{4}} & e^{-j\frac{14\pi}{4}} & e^{-j\frac{49\pi}{4}} \end{bmatrix} \begin{bmatrix} a(0) + jb(0) \\ a(1) + jb(1) \\ a(2) + jb(2) \\ a(7) + jb(7) \end{bmatrix}$$

To maintain the orthogonality of the eventual pulse shaped waveforms, we process the real and imaginary channels by separate 8-point DFTs. Each of them is modulated through a DFT computation that outputs a label for each resulting complex component contribution to the

modulated signal. A bank of polyphase filters takes each one of these outputs and translates the labels into 8-bit amplitude words. These are finally summed and the result is sent as the modulated signal.

### **IDFT Approach at the Receiver**

On the receiver side, we will be able to separate the data's real and imaginary components. We will then need to implement an efficient, straight computation of the IDFT. The Small-N (N=8) DFT algorithm equations are an adaptation from those found on the handbook of Digital Signal Processing [1]. The IDFT are computed by the following method:

IDFT by means of DFT;  $(1/N)X^*(n)$  where  $X(n)$  is the DFT function and the \* denotes a conjugate operation.

The equations are expanded for an 8-point DFT for our specific case of separate real and imaginary signal components. The result was a dual set of equations for the outputs of interest. We take advantage of the LUT approach possible in FPGA devices by cutting down the multiply operations. Since the amplitude data will have a finite length of 8 bits, we are able to predict all possible amplitudes. Then instead of a traditional multiply operation, we will "look-up" the result of the multiplication. On the receiving end we recuperate the original modulated data for each of the four channels through an IDFT computation. This data is then passed on to decoding and demodulation.

### **Polyphase Filters Design**

In most OFDM systems, the modulated data is left unshaped with each channel having a response that falls off as  $\sin(T_s)/T_s$ . When the number of channels is large, this does not adversely affect the overall system bandwidth efficiency. However, in this system where the number of channels is only four, unshaped modulated data caused excessive bandwidth use. To alleviate this situation shaping filters can be applied to limit the overall bandwidth. However, this diversion from sinc functions in the frequency domain must be applied carefully to limit intersymbol interference and maintain adjacent channel orthogonality.

From a hardware architectural view, the number of taps in the overall filter should be kept small. Since the added complexity of interpolation filters is not warranted, the number of samples per symbol is defined from the DFT size; in this case it is 8. Furthermore, the number of symbols that the filter is defined over is set to two. This was chosen to limit the size of each polyphase filter to two taps, which greatly eases the implementation complexity in FPGA. Thus the overall filter is a 16-tap filter. In addition to the 16 taps constraint, the filter must also limit ISI and ICI. Generally speaking, the goals of shaping filter designs are to limit the bandwidth without causing ISI using a limited number of taps. The root raised cosine (RRC) pulse is a good candidate, but is not optimum. To get a truly optimum filter, one has to attempt to design a filter that is both finite in time and in frequency, fundamentally an impossible task! To find the coefficients of the filter, we first started with a truncated square root raised cosine (SRRC) function [2].

The transmit polyphase filter uses the amplitude labels output from the DFT LUTs as input addresses to groups of 16X8 LUTs that perform the coefficient multiply operations. There are fundamentally two types of polyphase filter elements. The first is called the Small Polyphase

Unit (SPU) shown in Figure 1, and the second, the Large Polyphase Unit (LPU) shown in Figure 2. Each SPU use one 4-bit DFT output label and each LPU use one 5-bit DFT output label.

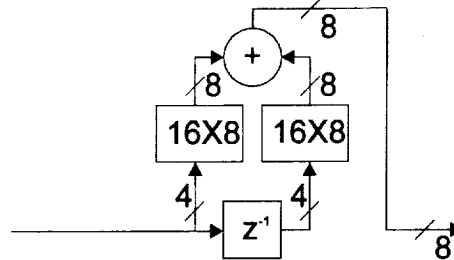

Figure 1- Small Polyphase Unit

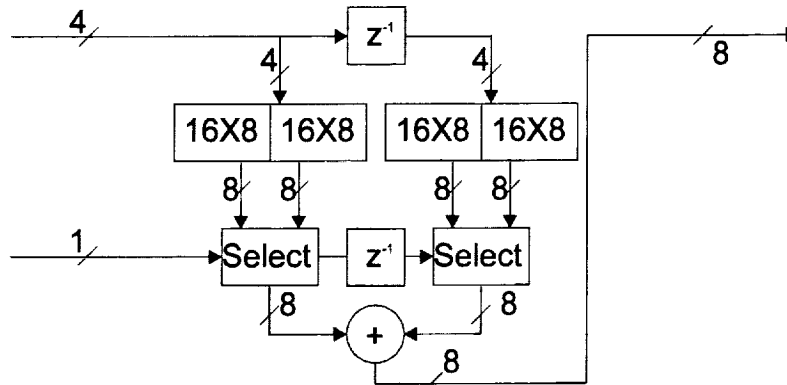

Figure 2- Large Polyphase Unit

The SPU is a realization of a two-tap FIR filter. Since there are only 16 possible output levels from the appropriate DFT bin, there are only 16 possible results at the output of each coefficient multiply. Thus a 16X8 LUT is used as the coefficients multiply operation. The adder and delay element perform the same function as in a conventional FIR filter. The LPUs are slightly more complex since it has a 5 bit input. The 5 bits require that there be two 16X8 LUT for each tap with the fifth bit selecting which output to use. Other than that, it is equivalent to the SPU.

At the receiver, it is not possible to use amplitude labels since the incoming data from the ADC is a noise-corrupted version of the transmitted data in which the amplitude levels carry important information. Thus, the receive polyphase filter must operate with data quantized to the Analog-to-Digital Converter (ADC) width, in this case 8 bits. To decrease the implementation complexity, the 8-bit fixed-point coefficient multiply operations are replaced by a canonical-signed-digit (CSD) representation that reduces to multiplies to a limited number a fixed shifts and additions or subtractions [3]. The CSD coefficients are found by starting with the floating point representation and a specification of number of quantization levels and the number of nonzero elements allowed per coefficient. There are a number of methods available in the literature [4] to search for the best set of CSD coefficients. In our case, we fix the number of quantization levels to 256 and limited the number of nonzero digits in the CSD representation to 1 and 2. Furthermore, we allow one additional nonzero digit for coefficients larger than some value  $s$  as in [3]. An algorithm then steps through gain factors from 0.5 to 1.0 with a predefined step size. At each gain factor the algorithm finds the closest CSD representation for each coefficient. The mean square error for this set of coefficients is then determined and compared to the mean squared error for the previous gain factor and the better

set of coefficients is kept. At the end, the best set of coefficients is kept. The quality of the coefficients is determined by examining the spectral response of the CSD filter as compared to the response of the floating-point version, and by inserting the CSD filter into a time domain simulation that determines the BER using a semi-analytic approach.

### **System Modeling and Simulations Results**

An OFDM system model is being developed using the Signal Processing WorkStation tools. The basic OFDM waveform is constructed by dividing an incoming data stream into four channels. The baseline rate 7/8 16QAM Four Dimensional Pragmatic Trellis Coded Modulation (4D-PTCM) scheme [6] with a Reed-Solomon (RS) (255,239) is being developed for each of the four channels. In addition to the baseline rate 7/8 16QAM, the trellis encoder also supports rate 5/6 8-PSK and rate 3/4 16QAM. After trellis encoding, the bits are mapped into modulation symbols represented by I- and Q-amplitude levels [5]. The bit to symbol mapping is chosen in accordance with the encoding scheme to obtain the full benefit of TCM. We then process each channel's modulated waveform through a DFT computation that produces a label for each resulting complex component contribution to the modulated signal. The polyphase filters takes these outputs and translates the labels into 8-bit amplitude words. These are finally summed and the result is sent as the modulated signal. At the receiving end, since the incoming data from the ADC is severely corrupted by noise, it is impossible to use amplitude labels. Therefore, the receive polyphase filters (CSD) must take the data quantized to the ADC width and process. We recover the original modulated data for each of the four channels through an IDFT computation. The data is then passed on to decoding and demodulation.

The simulation model contains four channels (each with encoder and modulator), DTF block, Polyphase Filters at the transmitter; and polyphase filter (CSD), IDFT block and four channels (each with decoder and demodulator) at the receiver. A pseudo-random number generator is used to produce binary signal sequences. An Additive White Gaussian Noise (AWGN) source of zero mean and power spectral density  $N/2$  is used to add channel noise to the system. The Bit-Error-Rate (BER) performance in the AWGN channel is evaluated and the BER plots of various schemes are shown in Figure 4.

### **Conclusion**

An OFDM system is developed by splitting the incoming data stream into a number of low rate channels ( $N=4$ ) that are stacked in frequency and separated by  $1/\text{symbol rate}$ . The baseline configuration of the system supports the OC-12 data rate of 622 Mbps. To achieve an efficient implementation, the combination of DFT and IDFT for frequency translations, and polyphase and CSD filters for pulse shaping are used. The four-channel approach enables the implementation of a system that can be both power and bandwidth efficient, yet enough parallelism exists to meet higher data rate goals.

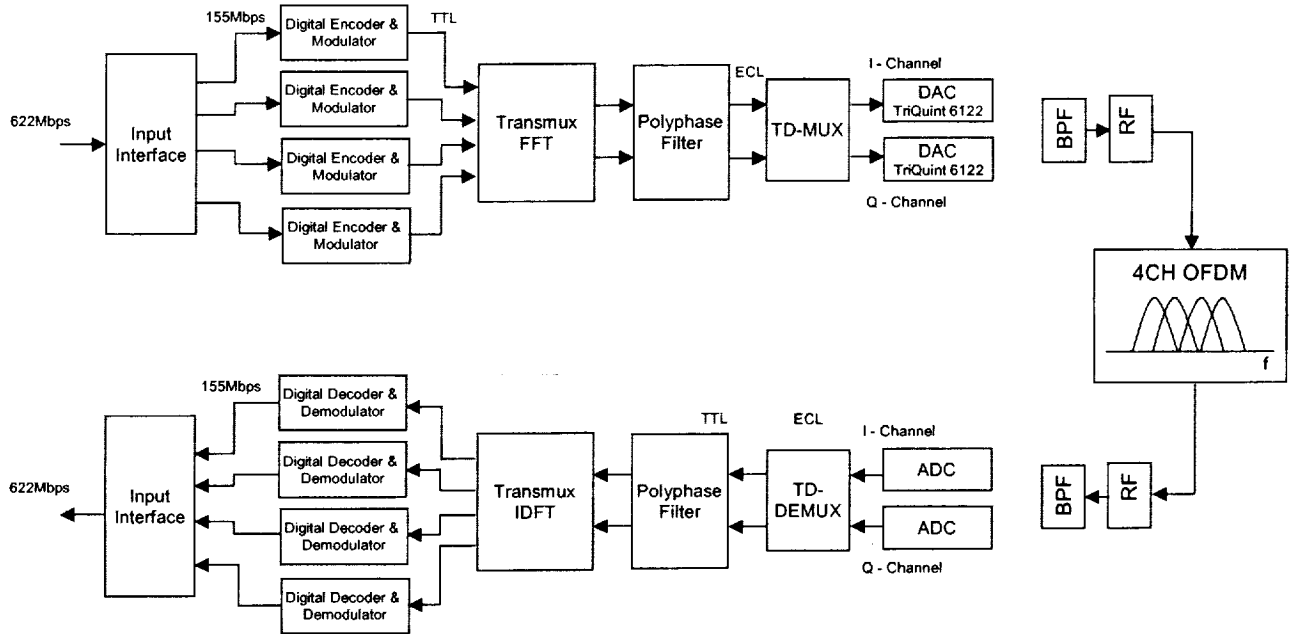

**Figure 3- 622 Mbps OFDM Modem System**

*Four-Channel OFDM System*

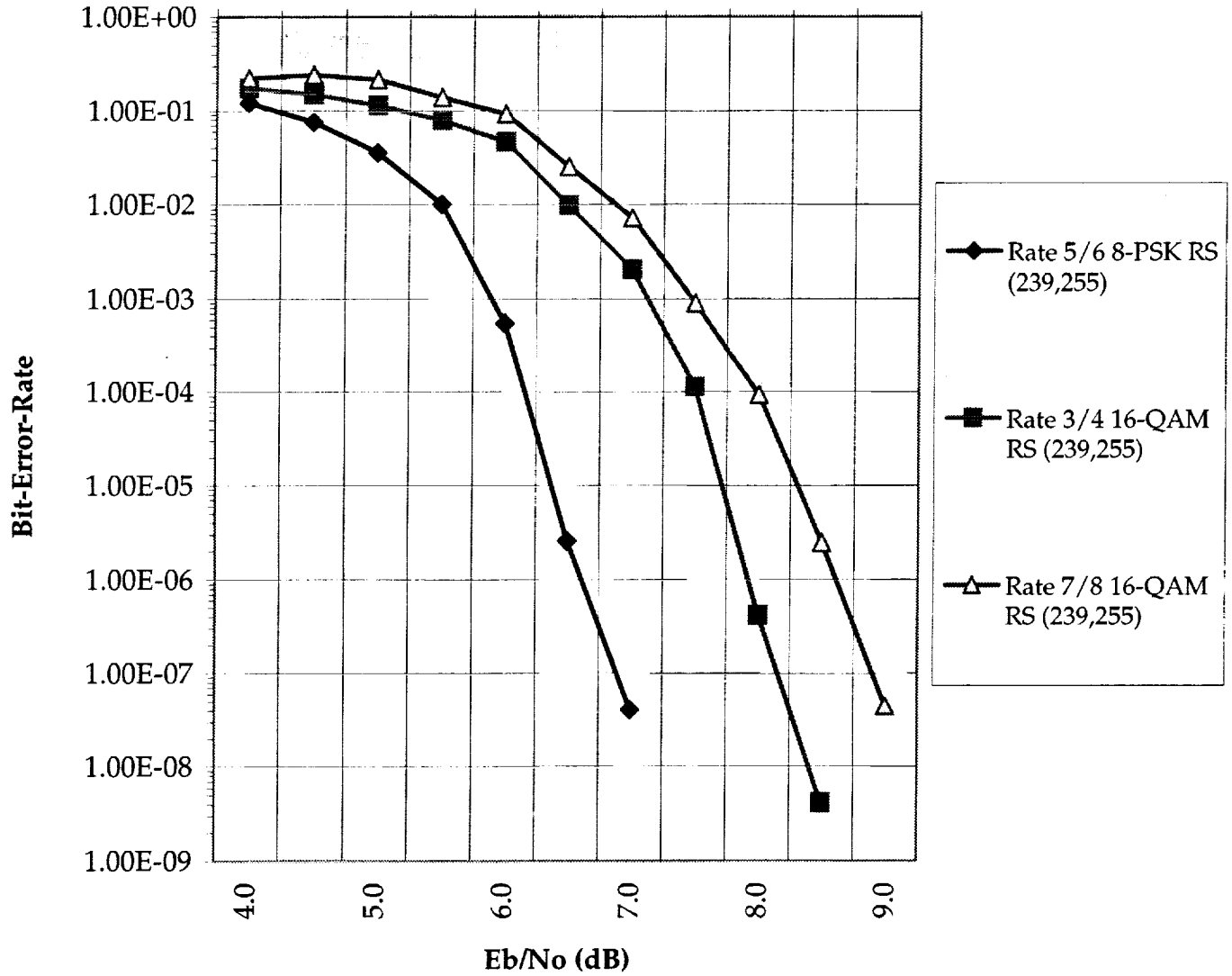

**Figure 4- Floating-Point Simulation Results**



## References

1. Elliott, Douglas F., "Handbook of Digital Signal Processing Engineering Applications", Chapter 7: Fast Fourier Transforms, Appendix A: Small-N DFT Algorithms, p.597, Academic Press, Inc., San Diego, CA 1987.
2. P. Chevellet, G. Ungerboeck, "Optimum FIR Transmitter and Receiver Filters for Data Transmission over Band-Limited Channels", IEEE Trans. Comm., vol. COM-30, No. 8, Aug. 1982.
3. Kim, Heechul, "Computer Simulation Results and Analysis for a Root-Raised Cosine Filter design using Canonical Signed Digits", NASA Tech. Mem.107327, October 1996.
4. Q. Zhao and Y. Tadokoro, "A Simple Design of FIR Filters with Power-of-Two-Coefficients", IEEE Transaction on Circuits and Systems, Vol. 35pp. 566-570, May 1988.
5. M. Kifle, et al, "Bounds and Simulation Results of 32-ary and 64-ary Quadrature Amplitude Modulation for Broadband-ISDN via Satellite", NASA Tech. Mem.106484, February 1994.
6. M. Vanderaar, et al, "A Low Complexity Encoder-Modulator for High Data Rate Satellite BISDN Applications", MILCOM '96, McLean VA, October 1996.
7. H. F. Harmuth, "On the Transmission of Information by Orthogonal Time Functions", AIEE Trans. (Commun. Electron.), vol. 79, pp. 248-255, July 1960.
8. A. Vahlin and N. Holte, "Optimal Finite Duration Pulse For OFDM", IEEE Transactions on Communications, Volume: 44 Issue: 1, January 1996.

# REPORT DOCUMENTATION PAGE

*Form Approved*  
OMB No. 0704-0188

Public reporting burden for this collection of information is estimated to average 1 hour per response, including the time for reviewing instructions, searching existing data sources, gathering and maintaining the data needed, and completing and reviewing the collection of information. Send comments regarding this burden estimate or any other aspect of this collection of information, including suggestions for reducing this burden, to Washington Headquarters Services, Directorate for Information Operations and Reports, 1215 Jefferson Davis Highway, Suite 1204, Arlington, VA 22202-4302, and to the Office of Management and Budget, Paperwork Reduction Project (0704-0188), Washington, DC 20503.

<b>1. AGENCY USE ONLY (Leave blank)</b>		<b>2. REPORT DATE</b> May 2001	<b>3. REPORT TYPE AND DATES COVERED</b> Technical Memorandum	
<b>4. TITLE AND SUBTITLE</b>  An OFDM System Using Polyphase Filter and DFT Architecture for Very High Data Rate Applications			<b>5. FUNDING NUMBERS</b>  WU-755-08-0B-00	
<b>6. AUTHOR(S)</b>  Muli Kifle, Monty Andro, and Mark J. Vanderaar				
<b>7. PERFORMING ORGANIZATION NAME(S) AND ADDRESS(ES)</b>  National Aeronautics and Space Administration John H. Glenn Research Center at Lewis Field Cleveland, Ohio 44135-3191			<b>8. PERFORMING ORGANIZATION REPORT NUMBER</b>  E-12728	
<b>9. SPONSORING/MONITORING AGENCY NAME(S) AND ADDRESS(ES)</b>  National Aeronautics and Space Administration Washington, DC 20546-0001			<b>10. SPONSORING/MONITORING AGENCY REPORT NUMBER</b>  NASA TM-2001-210813	
<b>11. SUPPLEMENTARY NOTES</b>  Prepared for the 19th International Communications Satellite Systems Conference and Exhibit cosponsored by the AIAA, CNES, ESA, and SUPAERO, Toulouse, France, April 17-20, 2001. Muli Kifle and Monty Andro, NASA Glenn Research Center, and Mark J. Vanderaar, Efficient Channel Coding, Inc., Brooklyn Heights, Ohio 44131. Responsible person, Muli Kifle, organization code 5650, 216-433-6521.				
<b>12a. DISTRIBUTION/AVAILABILITY STATEMENT</b>  Unclassified - Unlimited Subject Category: 32  Available electronically at <a href="http://gltrs.grc.nasa.gov/GLTRS">http://gltrs.grc.nasa.gov/GLTRS</a> This publication is available from the NASA Center for AeroSpace Information, 301-621-0390.			<b>12b. DISTRIBUTION CODE</b>	
<b>13. ABSTRACT (Maximum 200 words)</b>  This paper presents a conceptual architectural design of a four-channel OFDM system with an aggregate information throughput of 622 megabits per second (Mbps). Primary emphasis is placed on the generation and detection of the composite waveform using polyphase filter and Discrete Fourier Transform (DFT) approaches to digitally stack and bandlimit the individual carriers. The four-channel approach enables the implementation of a system that can be both power and bandwidth efficient, yet enough parallelism exists to meet higher data rate goals. It also enables a DC power efficient transmitter that is suitable for on-board satellite systems, and a moderately complex receiver that is suitable for low-cost ground terminals. The major advantage of the system as compared to a single channel system is lower complexity and DC power consumption. This is because the highest sample rate is 1/2 that of the single channel system and synchronization can occur at most, depending on the synchronization technique, 1/4 the rate of a single channel system. The major disadvantage is the increased peak-to-average power ratio over the single channel system. Simulation results in a form of bit-error-rate (BER) curves are presented in this paper.				
<b>14. SUBJECT TERMS</b>  Communications			<b>15. NUMBER OF PAGES</b> 19	
			<b>16. PRICE CODE</b>	
<b>17. SECURITY CLASSIFICATION OF REPORT</b> Unclassified	<b>18. SECURITY CLASSIFICATION OF THIS PAGE</b> Unclassified	<b>19. SECURITY CLASSIFICATION OF ABSTRACT</b> Unclassified	<b>20. LIMITATION OF ABSTRACT</b>	