

THERMAL/FLUID ANALYSIS OF A COMPOSITE HEAT EXCHANGER FOR USE ON THE RLV ROCKET ENGINE

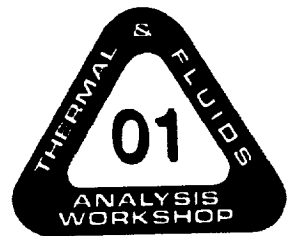

Dalton Nguyen
ED25/MSFC

ABSTRACT

As part of efforts to design a regeneratively cooled composite nozzle ramp for use on the reusable vehicle (RLV) rocket engine, an C-SiC composites heat exchanger concept was proposed for thermal performance evaluation. To test the feasibility of the concept, sample heat exchanger panels were made to fit the Glenn Research Center's cell 22 for testing. Operation of the heat exchanger was demonstrated in a combustion environment with high heat fluxes similar to the RLV Aerospike Ramp. Test measurements were reviewed and found to be valuable for the on going fluid and thermal analysis of the actual RLV composite ramp. Since the cooling fluid for the heat exchanger is water while the RLV Ramp cooling fluid is LH2, fluid and thermal models were constructed to correlate to the specific test set-up. The knowledge gained from this work will be helpful for analyzing the thermal response of the actual RLV Composite Ramp. The coolant thermal properties for the models are taken from test data. The heat exchanger's cooling performance was analyzed using the Generalized Fluid System Simulation Program (GFSSP). Temperatures of the heat exchanger's structure were predicted in finite element models using Patran and Sinda. Results from the analytical models and the tests show that RSC's heat exchanger satisfied the combustion environments in a series of 16 tests.

INTRODUCTION

Nasa is developing Advanced Technology Composite Aerospike Nozzle Ramp for potential use on reusable launch vehicles (RLVs). The primary drivers for the high risk, high payoff composite ramp concept are reduced weight relative to current designs and increased high temperature performance. Thermal and fluid analyses were performed to find if any composite heat exchanger designs meet the RLV requirements. This independent study also provides potential design options that may lead to a feasible nozzle ramp design. To test the feasibility of the designs, sample heat exchanger¹ panels were made to fit the Glenn Research Center's cell 22 for testing. Operation of the heat exchanger was demonstrated in a combustion environment with high heat fluxes similar to the RLV Aerospike Ramp. Test measurements were reviewed and found to be valuable for the on going fluid and thermal analysis of the actual RLV composite ramp. Since the cooling fluid for the heat exchanger is water while the RLV Ramp cooling fluid is LH2, fluid and thermal models were constructed to correlate to the specific test set-up. The heat exchanger's cooling performance was analyzed using the Generalized Fluid System Simulation Program (GFSSP)². Temperatures of the heat exchanger's structure were predicted in finite element models using Patran³ and Sinda⁴ codes.

COUPLE D FLUID/THERMAL ANALYSIS

The heat exchanger test article, shown in Figure 1, includes 9 composite tubes, inlet and outlet manifolds, and instrumentation ports. Cooling performance the CMC panel was analyzed using the Generalized Fluid System Simulation program (GFSSP). Temperatures of the panel structure were predicted in finite element models using Patran and Sinda. A schematic of the GFSSP model is shown in Figure 2. The coolant thermal properties are taken from test data. From the inlet manifold to each of 9 tubes, the flow coefficient⁶ is 0.6. At the 90 degree elbow, the flow restriction is defined by the 2k method⁷ ($k_1 = 800$ and $k_2 = 0.2$.) The surface roughness inside the tubes is 0.0019 inches (50 μm). Heat transfer coefficients for the combustion gas, shown in Figure 3, were provided by the Rockwell Science Center from a series of calibration tests. Thickness of the CMC layer is 0.030 inches with a thermal conductivity of 5.8 BTU/hr-ft- $^{\circ}\text{F}$ in the transverse direction, and 10 BTU/hr-ft- $^{\circ}\text{F}$ in the longitudinal direction.

Results:

Figure 4 shows how the water mass flow rate depends on the water pressure difference between the water inlet and outlet ports. Pressure drops range from 4.63 psid to 22.95 psid for 16 tests. The water mass flow rate predictions are consistently higher than the test measurements. Average deviation was found to be 8.5% for a series of 16 tests. The source of this variation may be the accuracy of the interior surface roughness of 0.0019 inches that was used in the model.

Temperatures of the water outlet in tests 668, 671, and 672 in which the mass flow rates are about 1.5 lbm/sec are 123 $^{\circ}\text{F}$, 136 $^{\circ}\text{F}$, and 141 $^{\circ}\text{F}$. When the water mass flow rates increased to 3.0 lbm/sec in tests 663, 664, and 665, the water outlet temperatures decreased to 97 $^{\circ}\text{F}$, 99 $^{\circ}\text{F}$, and 101 $^{\circ}\text{F}$ respectively.

The temperature of the outside surfaces were calculated for tests 668, 671, and 672 to be 2410 $^{\circ}\text{F}$, 2630 $^{\circ}\text{F}$, and 2860 $^{\circ}\text{F}$ respectively. They are below the use temperature limit⁴ of 3000 $^{\circ}\text{F}$. The Figures 6 to 8 show thermal elements and temperatures of the panel for tests 671, and 672. As the water mass flow rate increases to 3.0 lbm/sec, temperatures of the outside surface were found to be 1950 $^{\circ}\text{F}$, 2040 $^{\circ}\text{F}$, and 2580 $^{\circ}\text{F}$ for conditions of test 663, 664 and test 665 respectively. Overall the outside surface temperatures were below the limit temperature of 3000 $^{\circ}\text{F}$ for all cases.

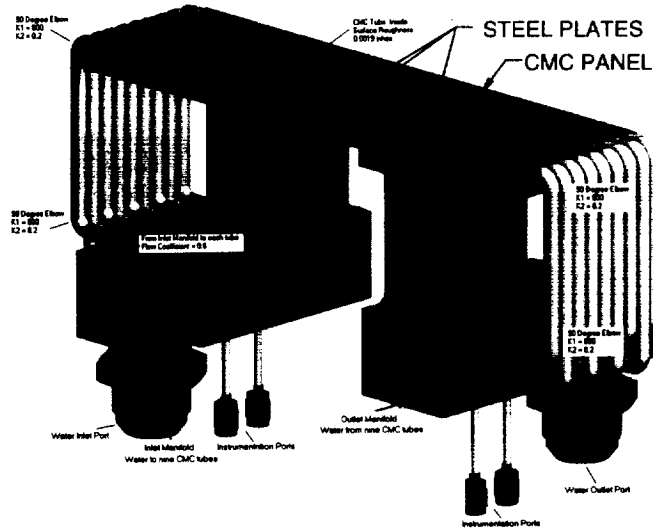

Figure 1:
Test Article Assembly with Instrumentation Ports

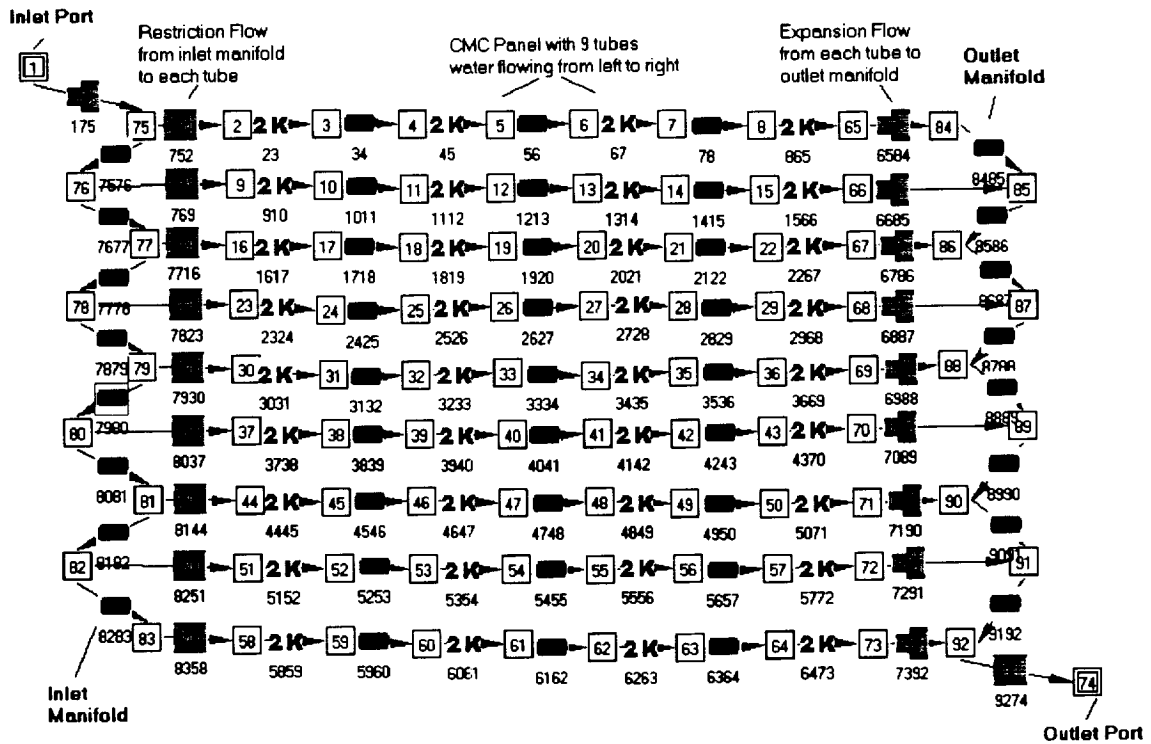

Figure 2: GFSSP model schematic of 9 tube panel
with inlet and outlet manifolds

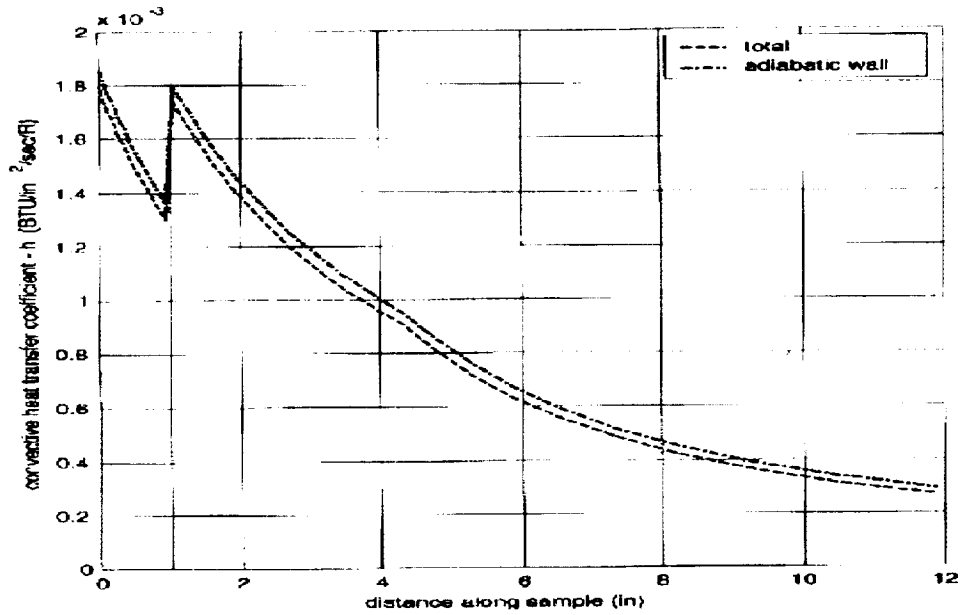

Figure 3: Heat Transfer Coefficient
Cell 22 Calorimeter test Results

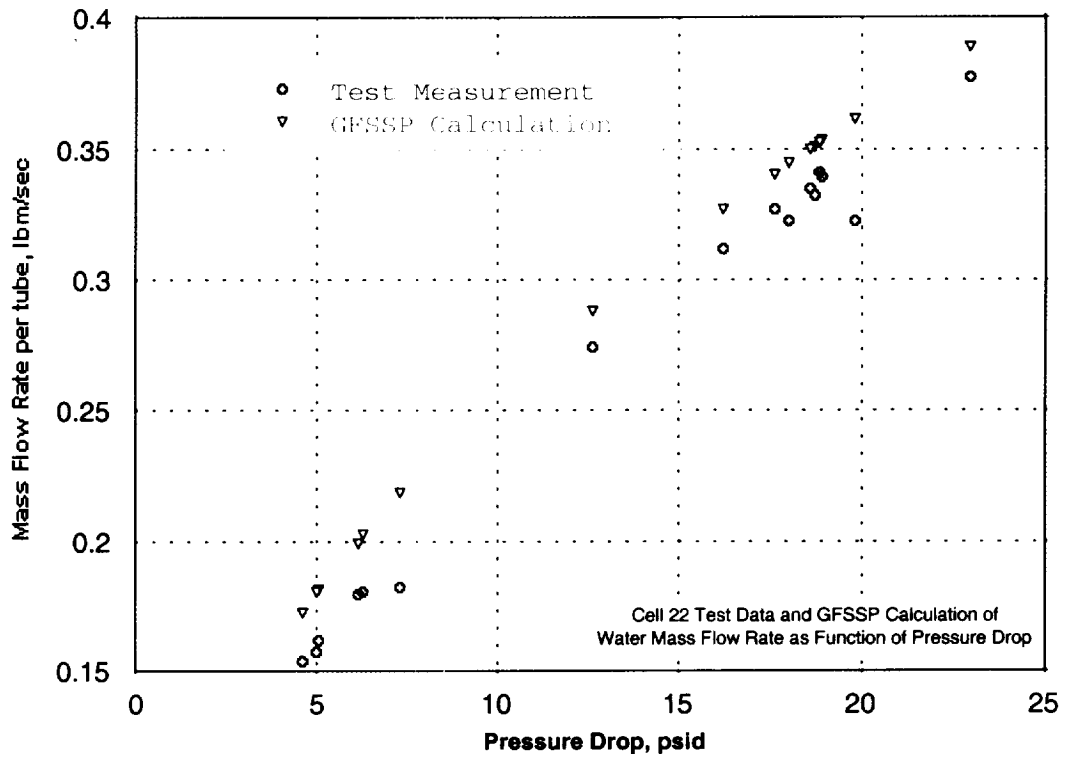

Figure 4: Test measurements and GFSSP calculation of
Water Mass Flow rate as Function of Pressure Drop

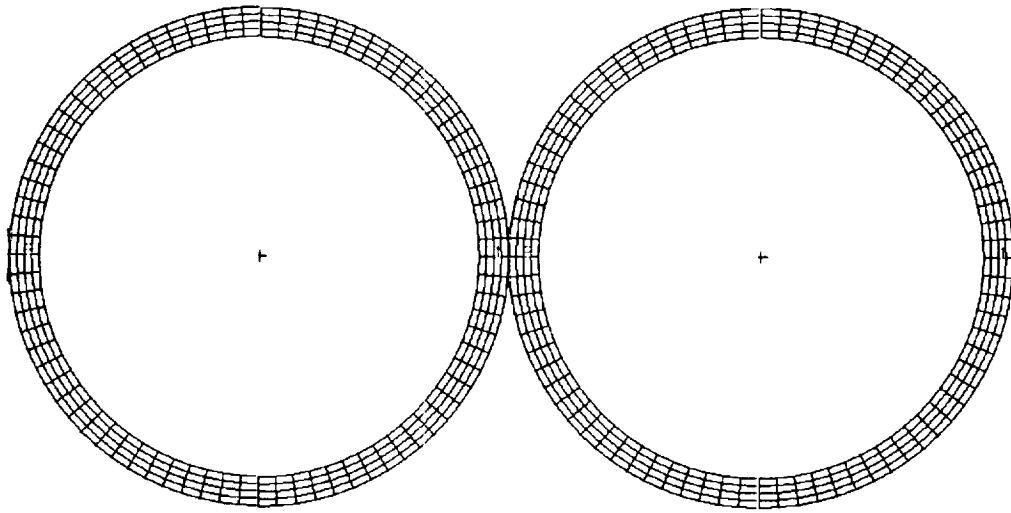

Figure 5: Thermal Element Model

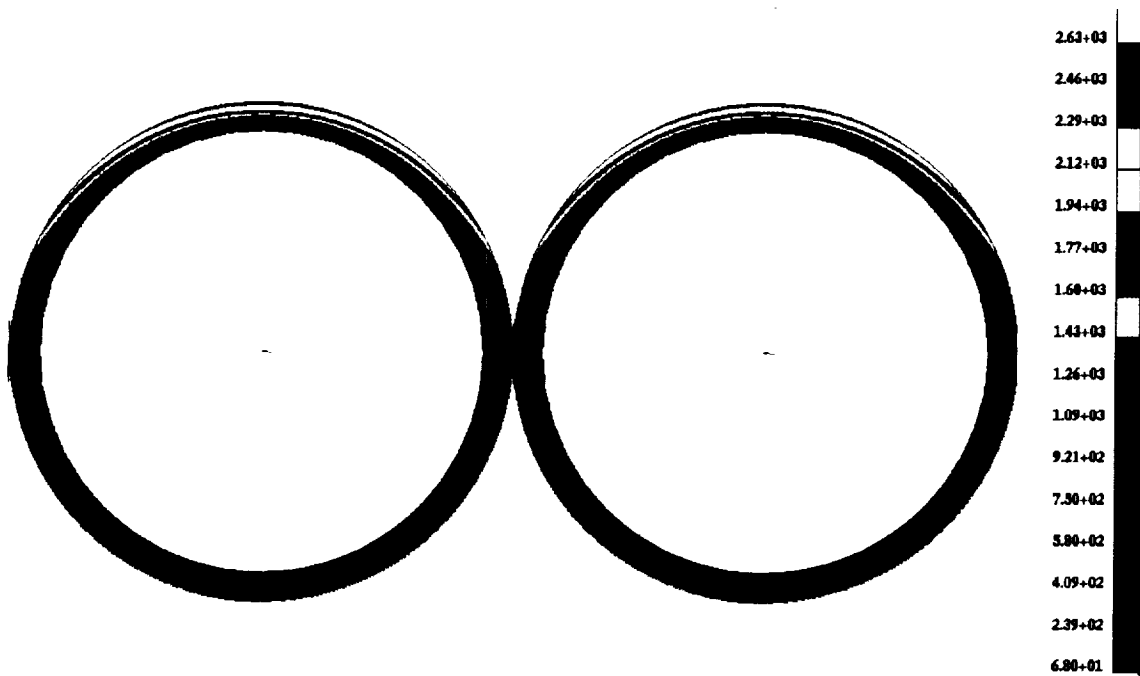

Figure 6: Temperatures of Composite Panel
for Test 671 Combustion Environment

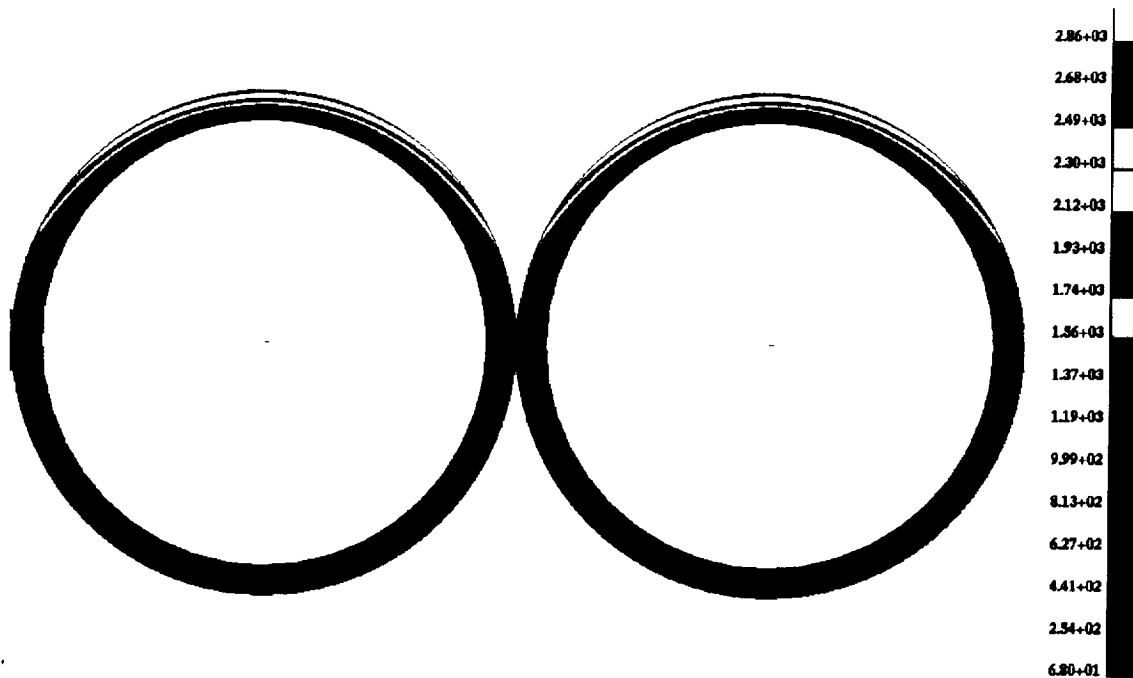

Figure 7: Temperatures of Composite Panel
for Test 672 Combustion Environment

CONCLUSIONS

The heat exchanger's cooling performance was analyzed using the GFSSP. Temperatures of the heat exchanger's structure were predicted in finite element models using Patran and Sinda. Results from the analytical models and the tests show that RSC's heat exchanger survived the combustion environments in a series of 16 tests. The outer surface temperatures of the heat exchanger were found to be below the use limit. The knowledge gained from this coupled fluid and thermal analysis will be helpful for analyzing the thermal response of the actual RLV Composite Ramp.

ACKNOWLEDGEMENTS

The author wish to acknowledge the contributions of J. Stout (Boeing-Rocketdyne), and D. Marshall (Rockwell Science Center).

REFERENCES

1. Rockwell Science Center: "Testing of Ceramic Composite Panels at NASA GRC's Cell 22." January 04, 2001.

2. **Generalized Fluid System Simulation Program (GFSSP), Version 3.0**
3. **Patran Manual**
4. **Sinda/G User's Guide**
5. **Baumeister, T.: "Mark's Handbook..." 8thed, McGraw-Hill, New-York.**
6. **Hooper, W.B.: "The Two-K Method Predicts Heat Losses in Pipe Fittings." Chem. Engr., Aug 24 pp97-100, 1981.**