

Final Report NASA Grant NAG5-5044
An Experiment to Study Sporadic Sodium Layers in the
Earth's Mesosphere and Lower Thermosphere.

Charles M. Swenson
Department of Electrical and Computer Engineering
Utah State University / Space Dynamics Lab
E-mail: charles.swenson@usu.edu

1 Overview

The Utah State University / Space Dynamics Lab was funded under NASA Grant NAG5-5044, "An Experiment to Study Sporadic Sodium Layers in the Earth's Mesosphere and Lower Thermosphere". This investigation has been part of Cornell Universities Sudden Atom Layer Investigation (SAL). USU/SDL provided a electron density measurement instrument, the plasma frequency probe, which was launched on the vehicle 21.117 from Puerto-Rico in February of 1998. The instrument successfully measured electron density as designed and measurement techniques included in this version of the Plasma Frequency probe provided valuable insight into the electron density structures associated with sudden sodium layers in a collisional plasma. Electron density data was furnished to Cornell University but no science meetings were held by Cornell. Data from the instrument was presented to the scientific community at the URSI General Session in 1999. A paper is in preparation for publication in Geophysical Research Letters. The following document provides a summary of the experiment and data obtained as a final report on this grant.

2 Experiment Overview

The impedance characteristics of an antenna immersed in an ionospheric plasma has been used to determine electron density for over 30 years [1]. The typical instrumentation for making these measurements tracks an antenna resonance associated with the upper hybrid frequency of the plasma. Due to the high collision frequencies and low densities in the lower ionosphere these tracking probes typically fail. An instrument for tracking the upper hybrid frequency [4] and also for making impedance

magnitude measurements was designed, built, and flown on the Sudden Atom Layer (SAL) Rocket from Puerto-Rico in February of 1998, Fig. 1. Measurements were made in the D and E regions of the ionosphere or from about 90 km to about 115 km. The mission was a study of neutral metallic layers, such as sodium, which spontaneously occur at the base of the ionosphere (~ 90 km) and are routinely observed by LIDAR. An antenna deployment failure for a similar instrument launched from Poker Flat, Alaska in January of 1999 resulted in no valid data. A door deployment failure occurred in yet another rocket with a similar instrument launched in February of 2002 from Poker Flat, Alaska. Thus, there have been attempts to repeat these measurements but at this time the SAL data is unique.

3 Instrumentation

The data presented in this report originated from two instruments built by Utah State University / Space Dynamics Lab, see Fig. 1. A dipole antenna was used as a sensor. The DC probe used a ring near the base of the dipole antenna to measure the electron saturation current. The Plasma Frequency Probe (PFP) used the last 52.5 cm of the booms as an active antenna element. This instrument typically tracks the upper hybrid frequency by sensing the parallel antenna resonance.

The antenna for these measurements consisted of two booms deployed 180 degrees apart with a 3 meter tip to tip length and a 2.54 cm diameter. The last 52.5 cm of booms were used as the active elements of the antenna. The antenna was driven with a 1 volt sinusoidal signal at forty different fixed frequencies from 200 kHz to 12 MHz. The magnitude of the current flow to the antenna was recorded at each of these frequencies in a sweep lasting 5 ms.

The PFP was modified to provide a measurement of current magnitude at forty different fixed frequencies from 200 kHz to 12 MHz. This sweep measurement was made when the parallel antenna resonance could not be tracked. For the SAL payload the upper resonance was never tracked and the entire data set consists of sweeping data. The antenna was driven with a 1 volt sinusoidal signal. The current flowing to the antenna was monitored using a RF current transformer as illustrated in Fig. 2. The load impedance, Z_t , on the transformer consisted of a $1\text{ K}\omega$ resistor in parallel with a 3 pF capacitor. These elements combined with the inductance of the transformer to give a second or-

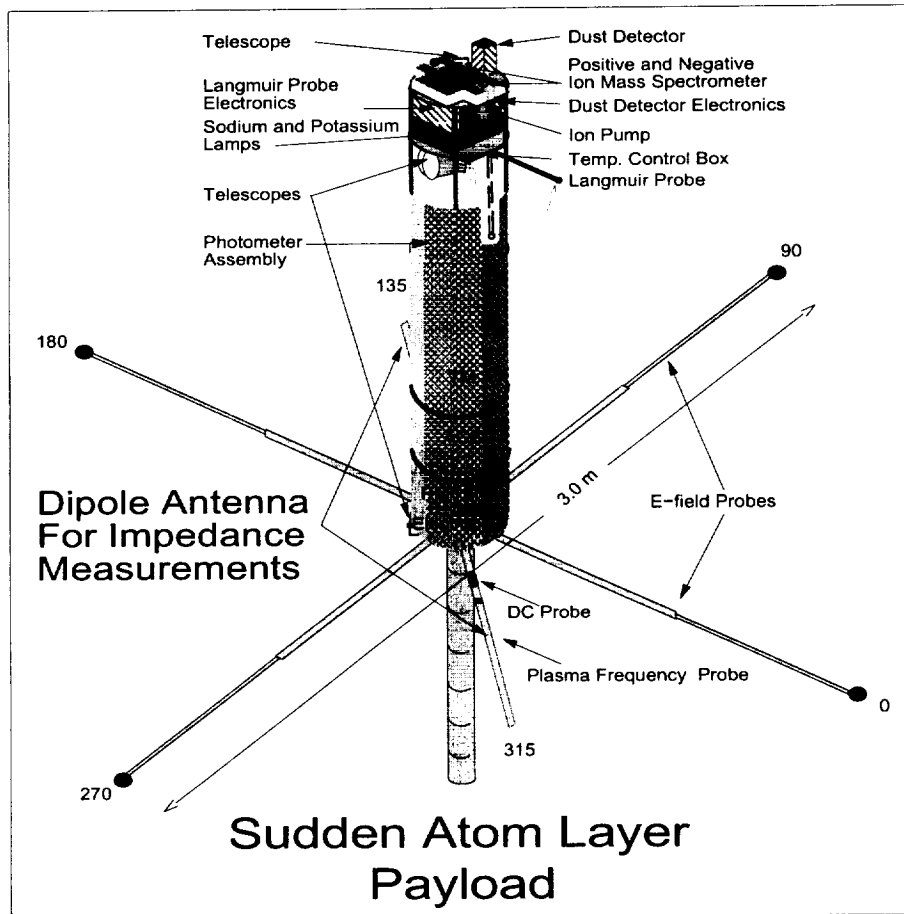

Figure 1: The Sudden Atom Layer Rocket (NASA 21.117) was launched February 20, 1998 at 00:09:00 Local Time. This Cornell University payload included instruments from Utah State University, University of New Hampshire, the Naval Research Labs, NASA, and The Aerospace Corporation.

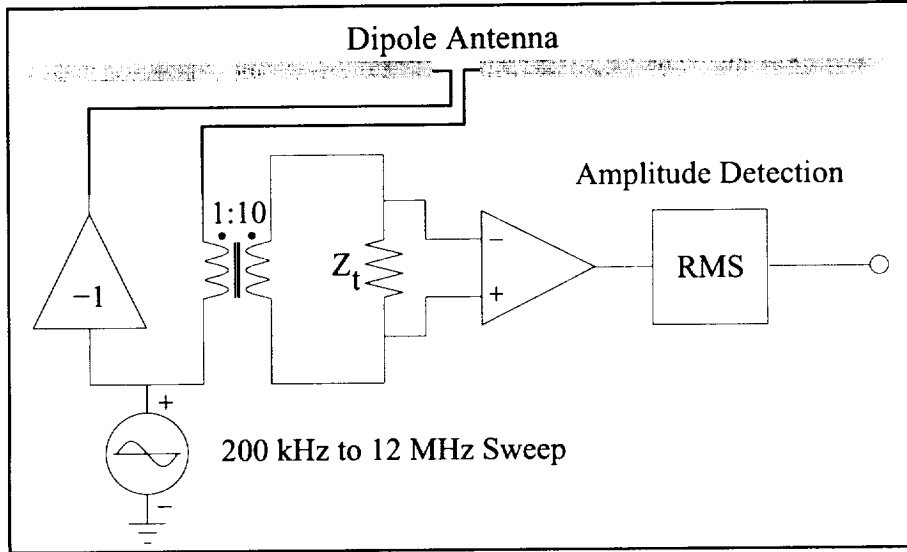

Figure 2: tbd

der characteristic input impedance to the instrument. The instrument was calibrated pre-flight without the dipole antenna using a series of resistors and capacitors. Calibration curves and measured data at several different altitudes are shown in Fig. 3. The data are the magnitude of antenna impedance plus a contribution from the instrumentation. Data is presented for several different altitudes.

4 Data Analysis

The observed current magnitudes are converted to impedance magnitudes using instrument calibrations made pre-flight. The data analysis approach was to compare the measured data to theory for antenna impedance in cold collisional magnetized plasma [2]. A least squares approach has been used to fit for the unknown parameters of plasma frequency, electron cyclotron frequency and electron neutral collision frequency. The data was modeled as a combination of three impedances; the antenna free space impedance - Z_o , the contribution due the plasma - Z_p , and instrumentation plus shunt contributions - Z_i .

$$\text{Data} = |Z_i + Z_o + Z_p|$$

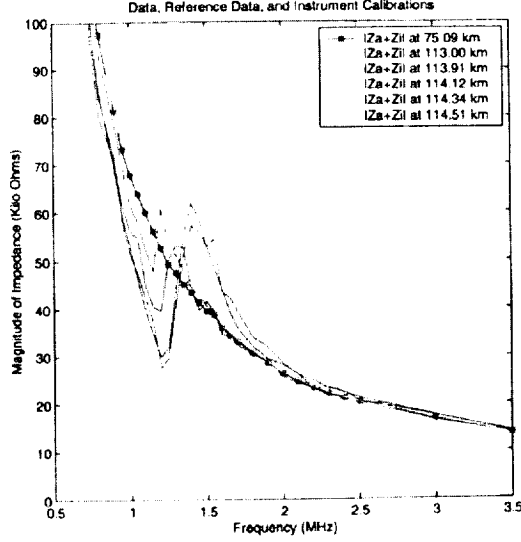

Figure 3: Calibration data and measured data comparison

The free space impedance plus instrument effects were modeled as

$$Z_{\text{ref}} = Z_i + Z_o = \frac{S}{S^2 + \frac{1}{RC}S + \frac{1}{LC}}$$

where $C = 2.85$ pF, $L = 41.2$ mH, and $R = 206$ K Ω .

Balmain's theory [2] for the impedance of an antenna in cold, collisional, magnetized plasma was used as a model. The impedance of this model is a function of three parameters; the plasma frequency - ω_p , the electron cyclotron frequency - Ω_e , and the electron neutral collision frequency ν_e .

$$Z_{\text{Balmain}}(\omega_p, \Omega_e, \nu_e) = Z_o + Z_p$$

The ratio of change, due to the ionospheric plasma, from free space impedance was computed by normalizing the data with a sweep at low altitude where the contribution of the plasma to the impedance would be small.

$$\frac{\text{Data}}{\text{Data}_{\text{ref}}} = \frac{|Z_i + Z_o + Z_p|}{|Z_i + Z_o|} = \left| \frac{Z_p}{Z_i + Z_o} + 1 \right|$$

This data was fit using a least squares approach with the model

$$\left| \frac{Z_{\text{Balmain}}(\omega_p, \Omega_e, \nu_e) - Z_o}{Z_{\text{ref}}} + 1 \right|$$

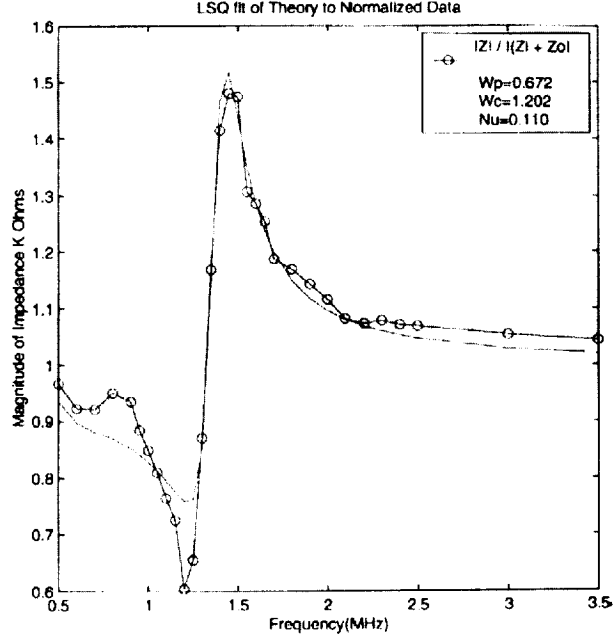

Figure 4: Data and fit by Balmain's theory

where Z_o was computed from Balmain's theory for $\omega_p \rightarrow 0$. An example data sweep and fit are shown in Fig. 4.

Electron density was computed from the fit for plasma frequency, $\omega_p^2 = \frac{n_e e^2}{\epsilon_0 m_e}$, and is plotted along with the current from the DC probe in Fig. 5. The DC probe data has been normalized to the impedance data at maximum density. The signature of the metallic atom layer at about 92 km altitude in both the up and down legs are clearly observable. We believe the payload charged while passing through the layer such that the DC probe experienced a ground reference shift and did not observe a strong signature of the layer. The strong spin modulation in the data from both instruments is due to the sensing element passing through the spacecraft wake.

The electron collision frequency is shown in comparison to a model in Fig. 6. The model is given by $\nu_e = 2.33 \times 10^{-11} n_n (T_e - 1.2 \times 10^{-4} T_e^2)$, where n_n is the neutral density in cm^{-3} . This equation is a reasonable approximation for T_e between 100 to 1000K. The velocity dependent cross section for N_2 is used alone to calculate the average electron momentum transfer collision frequency for an accuracy of about

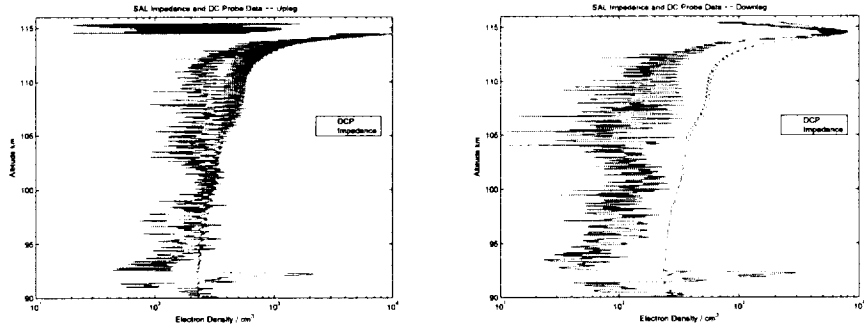

Figure 5: Density upleg and downleg derived from impedance data and from the DC-probe

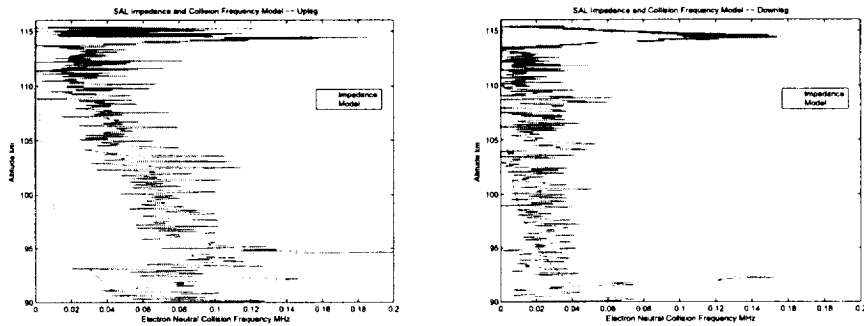

Figure 6: Collision frequency derived from impedance measurements and corresponding model calculations of collision frequency.

15 [3]. The neutral density was computed from the MSIS model for the launch location. We note large spin and apparent density variation dependence which are suspect.

The fit electron cyclotron frequency is shown in comparison to the electron cyclotron frequency computed from the IGRF/DGRF model in Fig. 7. Considerable disagreement exists between the parameter fit of the impedance data and this authoritative magnetic field model. A weak explanation for the discrepancy would be large fields from the neutral mass spectrometer experiment contaminated the data. We note large spin and apparent density variation dependence which are suspect.

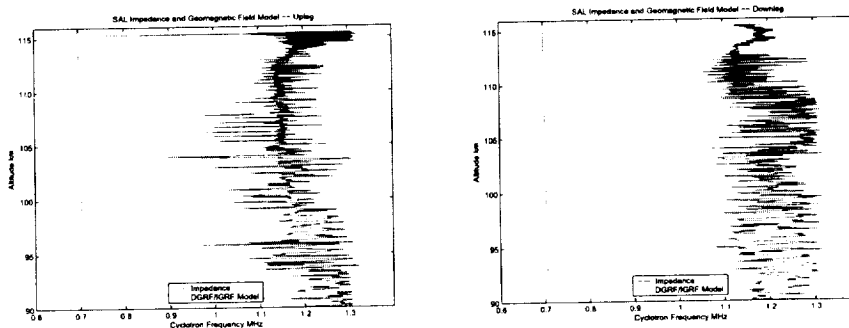

Figure 7: Electron cyclotron frequency calculations from impedance calculations and from IGRF model.

Conclusions

The instrumentation used to obtain the data was relatively crude and had a poor sensitivity at low frequency due to the current transformers. The approach of measuring just magnitudes is also not recommended since instrument calibration is awkwardly folded into the observed data.

The approach of least squares fitting the change of impedance using the theoretical impedance of an antenna in cold, collisional, magnetized plasma provided satisfactory data for electron density. This was done over a range of the ionosphere for which measurements are problematic. A more complete model of the impedance of an antenna in the ionosphere is probably not required until more accurate instrumentation and measurements are obtained. The measurements of electron neutral collision frequency are reasonable on a large scale but small scale dependence on density are unreasonable. The electron cyclotron fit shows an essentially unexplainable bias and unreasonable small scale dependence on density. Reasonable data is obtained for the plasma frequency while the corresponding fits for electron cyclotron frequency and electron neutral collision frequency are not as compelling. Interesting data are uncovered on the nature of sudden atom layers and their ionized component.

Utah State University / Space Dynamics Lab are currently developing a new generation of plasma frequency tracking probes coupled with swept impedance measurements that will allow more accurate testing of antenna impedance theories.

References

- [1] K. D. Baker, E. F. Pound, and J. C. Ulwick. Digital plasma frequency probe for fine scale ionospheric measurements. In Ken-Ichi Maeda, editor, *Small Rocket Instrumentation Techniques*, pages 49–57, Amsterdam, 1969. COSPAR, North-Holland Publishing Company.
- [2] K. D. Balmain. Impedance of a short dipole antenna in a magnetoplasma. *IEEE Trans. Antennas Propagat.*, AP-12(5):605–617, September 1964.
- [3] P.M. Banks and G. Kockarts. *Aeronomy*. Academic Press, 1973.
- [4] Mark D. Jensen and Kay D. Baker. Measuring ionosphere electron density using the plasma frequency probe. *Journal of Spacecraft and Rockets*, 29(1):91–95, January 1992.