

## THE DESIGN OF AN ULTRA HIGH CAPACITY LONG RANGE TRANSPORT AIRCRAFT

Purdue University  
School of Aeronautics and Astronautics  
West Lafayette, Indiana

Professor Terrence A. Weisshaar  
Gregory Bucci  
Angela Hare  
Matthew Szolwinski

### Abstract

This paper examines the design of a 650 passenger aircraft with 8000 nautical mile range to reduce seat mile cost and to reduce airport and airway congestion. This design effort involves the usual issues that require trades between technologies, but must also include consideration of: airport terminal facilities; passenger loading and unloading; and, defeating the "square-cube" law to design large structures. This paper will review the long range ultra high capacity or megatransport design problem and the variety of solutions developed by senior student design teams at Purdue University.

### Introduction

The objective of the senior design class of the School of Aeronautics and Astronautics at Purdue University was to provide a conceptual design for a new class of aircraft with a range of 8000 nautical miles to carry a maximum passenger load of 650 passengers, together with 30,000 pounds of cargo and to incorporate prudent amounts of advanced technology and new configuration concepts. Forecast production go ahead is 1996 with the first certificated airliners being delivered in 1999.

These large capacity airliners have been referred to as "super-jumbos", "megatransports" or "megajets." We will use the term "megatransport." The term "mega" refers to the projected take-off gross weight (TOGW) of these aircraft, a number expected to exceed 1,000,000 lbs.

Increased air travel demand that is sure to follow economic recovery will provide an opportunity for airlines to increase revenues and an opportunity for airframe manufacturers to sell airplanes. On the other hand, increased traffic may also place a burden on airports, air traffic control and airways around the world, many of which are at or near traffic saturation levels. Northern Pacific routes are already congested at prime times because there are only two airways westbound and three eastbound.

To take advantage of increased traffic, while recognizing airport and airway congestion difficulties, airlines are considering new airplanes with more than 150% the capacity of the Boeing 747-400. Predictions for the number of new

large transports needed by 2010 range as high as 550 units.<sup>1,2</sup>

The last substantial increase in aircraft size occurred almost 25 years ago with the development of the Boeing 747. Megatransport designs will compete with existing Boeing 747 designs, the proposed MD-12 and possible new SST's being proposed for long range use.

This paper briefly reviews megatransport objectives and constraints, and summarizes some of the solutions developed by student design teams at Purdue University during a one semester course. It begins with a discussion of the market needs and the economic risks involved in such a project. It then summarizes some of the different approaches taken to solve the problem and the difficulties faced by the design teams. Finally, some "lessons learned" are discussed at the end of the paper.

### The Request for Proposal

This was the second year that senior design teams had considered the design of a large transport. On the basis of previous experience, a Request for Proposal was generated to reflect market conditions and demand. The primary difference this year was that the range was increased to 8000 nautical miles to provide a challenge and the number of passengers was chosen to be large, but not too large compared to existing designs. The Request for Proposal is summarized as follows.

### Regulations/certification

The aircraft must comply with Federal Aviation Regulation Part 25 (FAR25) and foreign equivalents. The engines must comply with Federal Aviation Regulation 36 (FAR36) and ICAO Article 16.

### Mission Performance

The still air range must be at least 8000 nmi. with a full load of 650 passengers and 30,000 pounds of cargo.

Fuel reserves equal to 5% of primary trip fuel must be included in the mission.

Cruise must begin at least at 35,000 ft. and Mach 0.85. The cruise Mach number at any operational altitude must be equal to or greater than  $M=0.85$ .

The aircraft must be able to operate from international airports with a full passenger/cargo load using no more than 10,000 ft of runway. It must be able to land at sea level at 80% of TOGW using no more than 8500 ft. of runway.

The use of advanced materials is highly encouraged, consistent with safety, maintainability and cost requirements. Emphasis should be placed on minimal empty weight and cost.

The use of high bypass ratio turbofan engines is encouraged, consistent with cost and development considerations. It is strongly recommended that upgrades or modifications of existing engines be considered.

The use of advanced airfoils and innovative, multiple lifting surface concepts is strongly encouraged, consistent with customer acceptance and performance. Evidence of transonic area ruling must be presented in the final proposal.

The design of the fuselage must show evidence of concern for safety and for passenger comfort, loading and unloading. Compatibility with existing or slightly modified airport facilities likely to be in use in the year 2005 must be demonstrated. Carrying fuel in the fuselage is discouraged, but not prohibited. Using the entire length of the fuselage for a double deck passenger configuration is discouraged, but not prohibited because of loading and unloading and compatibility with current airports.

### Cost

Acquisition and operating costs are a major factor in evaluating the suitability of the design. These costs must be determined using generally accepted data and estimation procedures.

### Maintainability

The design must clearly show that maintenance and reliability have been considered.

### Data requirements

The technical proposal shall be specific and complete, but must be less than 100 pages, excluding the Appendix. This proposal must demonstrate a thorough understanding of the requirements and opportunities for the design RFP.

Critical technical issues and problem areas must be clearly identified in the proposal and adequately addressed. Descriptions, sketches, drawings and analysis, method of approach and discussions of new techniques should be presented in sufficient detail to permit accurate engineering

evaluation of the proposal. Exceptions or modifications to the proposed technical requirements presented above must be identified and explained. Aerodynamic analysis using LINAIR, VORLAT and PMARK is required.

Trade-off studies must be performed and included in the proposal to describe how the final design was arrived at. A history of the design development, including possible designs that were rejected and their reasons for rejections, must be included.

### The Final Proposal Report

Based on the previously stated objectives, requirements and constraints the final report must include sections and/or data on the following:

- 1) Justify the final design by describing the aircraft's performance and listing its advantages compared to other existing and proposed designs. Include aircraft design and sizing trade studies.
- 2) Include a three-view drawing in the final proposal. This drawing must show important dimensions (in English and metric units), payload and passenger locations, fuel locations, crew location and crew accommodations, flight control systems and any unique or unusual features.
- 3) Weight and balance data must be provided together with a description of loads and structural materials and their location. Provide a center of gravity envelope diagram showing extreme c.g. locations relative to the aircraft aerodynamic center. This data must be provided in terms of a mean aerodynamic chord reference.
- 4) Describe techniques or methods used to determine aircraft performance, stability, control and handling qualities. Indicate the results of these techniques. Show compliance with FAR25.
- 5) Summary of design trade-offs - Describe why the final design was chosen. Describe why this design is optimal for the intended use. Describe the sensitivity of the design to changes in parameters such as aspect ratio, wing area, wing thickness, engine TSFC, range, materials choice and other design choices.
- 6) Provide cost data and sensitivity of the aircraft price to such parameters as number produced, cost of capital, take-off gross weight and government grants.

### Basis of Judging

Responses to this proposal will be judged in four primary categories.

**Technical Content** The correctness of theory, validity of reasoning, apparent understanding and grasp of the problem.

**Organization and Technical Presentation** The ability to present a description of the design and to clearly communicate its advantages is an essential factor in evaluation. Organization of the design report, clarity and skillful inclusion of pertinent data are major factors in this evaluation.

**Originality** The design proposal should show that there was independence of thinking or a fresh approach to the problem. Does the method and treatment of the solution show imagination or extend previous efforts or is it simply a rehash of an existing solution? Evidence of team effort and participation are essential.

**Practical Application and Feasibility** The proposal should present conclusions and recommendations that are practical and feasible and not merely lead the evaluators into other unsolvable problems. Has the team made mention of shortcomings and made recommendations for further improvement if time permitted?

### Challenges and Advantages of Megatransport Design

The design of an aircraft such as proposed in the above RFP poses some unique problems. Design addresses a customer need and then proposes a solution. The consideration of need requires an answer to the question "Is there a market for large capacity, megatransport airliners?"

During 1991 the operating losses of major airlines exceeded the total profits earned since the introduction of jet transportation in the 1950's. In 1992 airlines continued to lose money. Despite this and the worldwide economic growth problems, the demand for air travel is predicted to resume its growth within the next few years.

The number of airline revenue passenger miles (RPM) is predicted to more than double by the year 2010. Boeing predicts that the number of available seat miles (ASM) will increase by more than 180 percent to meet air travel demands in the year 2010.<sup>2</sup> Markets to consider include both domestic and international routes.

Table 1. Percentage of total available seat miles (ASM) by airlines to and from three regions (1991 value / 2010 forecast)<sup>1</sup>

Travel to/by	US Airlines	Europe	Asian
North America	61% / 56%	32% / 26%	28% / 28%
Europe	21% / 20%	40% / 36%	17% / 28%
Asia-Pacific	12% / 20%	12% / 27%	47% / 41%

Domestic marketing concentrates on frequent flights to and from destinations. As a result, the number of passengers per flight is too small to justify a large capacity aircraft. Overseas markets with high demand, but only a few flights a day, have the most potential for generating revenue. The fastest growing markets for North America appear to be in the Pacific Rim region. The economic growth there indicates that this trend will continue. Table 1 shows a prediction of the available seat miles (ASM) categories by routes for U.S., European, and Asian airlines.<sup>1</sup>

Airlines favor buying aircraft with a range equal to the B-747. Recent articles appear to favor aircraft ranges of between 7500 and 8000 nautical miles.<sup>3</sup> On the other hand, each nautical mile of range increases take-off gross weight TOGW substantially and few airport pairs are located more than 7000 nautical miles from each other.

To reach out to these markets, we require a long range aircraft. The cruise portion of the flight dominates the mission of the long range transport. Estimating the fuel required for a cruise dominated mission with the Breguet range equation illustrates fuel requirements. This estimate reads:

$$W_{fuel} \equiv W_{TO} \left( 1 - e^{\frac{-Rc_j}{MaL/D}} \right) \quad (1)$$

where R=range,  $c_j$ = thrust specific fuel consumption, M=cruise Mach number, a=speed of sound at cruise altitude and L/D is the estimated value of cruise lift to drag ratio.

Equation 1 shows that the fuel required for the mission approaches the TOGW as range R increases. It is not unusual for the fuel fraction (ratio of fuel weight to take-off gross weight) to be of the order of 0.45, even if the aerodynamic efficiency (ML/D) is high and the engine TSFC  $c_j$  is low.

For preliminary estimates of the TOGW, we can use the relationship of the form

$$W_{TO} \equiv \frac{W_{payload}}{1 - \bar{m}_{fuel} - \bar{m}_{empty}} \quad (2)$$

where  $\bar{m}_{fuel}$  is the fuel fraction  $W_{fuel}/W_{TO}$  and  $\bar{m}_{empty}$  is the empty weight fraction. The empty weight fraction becomes slightly smaller as TOGW increases.<sup>4</sup> This occurs because the dimensions and size of the megatransport allow for more efficient use of high strength materials in the structure and

more dramatic weight savings if advanced composite materials are used.

Increased aerodynamic efficiencies may also occur because parasite drag may be reduced due to the larger Reynolds numbers at which large aircraft operate. The coefficient of friction  $C_f$  decreases because of an increase in Reynolds Number. Assuming turbulent flow over the entire wing, the  $C_f$  is approximated by<sup>4</sup>

$$C_f = \frac{0.455}{(\log Re)^{2.58} (1 + 0.144 M^2)^{0.65}} \quad (3)$$

where  $M$  is the Mach number and  $Re$  is the Reynolds number. Aircraft with larger characteristic lengths (wing chord, fuselage length, etc.) will have smaller friction coefficients, all other things being equal. Even with these potential advantages, the megatransport TOGW quickly grows as the range increases.

Balancing these problems, operating costs, especially fuel cost per passenger mile, decreases as passenger number increases. There will be a minimum fuel cost for a given number of passengers and a given range. This minimum fuel cost reflects the economies of scale for any given design.

### Megatransport Special Design Issues

The large size of a transport with passenger capability exceeding the B-747 places demands on technology, including structures, manufacturing, landing gear and passenger configuration, to name a few items. These issues for the design of large transports are discussed in a variety of recent articles.<sup>5,6,7,8,9</sup>

#### Airports

The long range markets with high passenger demand are currently served by B-747, DC-10 and MD-11 aircraft. Boeing 747 airplanes not only the primary competition for the megatransport, they are the standard for designing terminal facilities and runways. Increased aircraft size beyond the B747 planform may require modifications to runway widths pavement thickness, taxiways and terminal facilities.<sup>10</sup>

Several constraints arise if existing facilities are to be serviced. These include service to airport terminals built to accommodate wingspans less than 220-240 feet and fuselage lengths of the order of 220 feet. This constrains the span of the megatransport wings and makes drag reduction difficult.

Another serious problem is the logistics of quickly loading or unloading 650 passengers. This includes not only jetways, but terminals and emergency conditions.

### Structural Design

Among other important issues faced by the structural designer of large transports is the so-called "square-cube law." The square cube law is a statement regarding the relationship between the loads, which are assumed to be proportional to weight, and the stresses in the structure. For similar structures of different scales, the load increases as the cube of linear dimensions and the cross-sectional areas increases as the square of the linear dimension.<sup>11</sup>

If the size of the object is doubled (for instance, we simply scale up an existing design) then the stresses double. Therefore for a given material with a given ultimate stress, the square-cube law limits the size of the object. As a result, we can not simply make the aircraft larger, we have to make it different.

Recent aircraft design has focused on using new materials and structural design techniques. New materials, such as aluminum-lithium, and advanced composite materials have allowed changes in structural design. This "defeats" or at least holds off the detrimental effects of the square-cube law and allows larger aircraft to be built.

Innovative configurations can also aid in "defeating" the square-cube law. The use of such configurations as joined-wing design, three-surface designs or flying wings can overcome pessimistic predictions of the square-cube law by allowing a redistribution of weight throughout the vehicle. Finally, the weight of some items on an aircraft are not functions of scale.

#### Fuselage design

Containment of passengers on a large transport requires an examination of how to keep the wetted area per unit volume at a low level. This objective must be tempered by safety and comfort requirements. Fuselage design is challenging because of aircraft maximum length constraints imposed by terminal facilities and the requirements for aerodynamic efficiency of the fuselage shape. This latter feature is usually at odds with terminal requirements because short, stubby fuselages are aerodynamically inefficient.

New fuselage cross-section layouts must be considered to satisfy fuselage length limits while increasing volume and minimizing wetted area. These new layouts include multiple deck configurations, elliptical single deck configurations and dual fuselage configurations.

The largest factor constraining fuselage design is safety. There must be enough emergency exits for the passengers to escape in 90 seconds. Multiple deck configurations have emergency exits far from the ground (40 feet or more), possibly compromising safety.

Because of previous efforts in fuselage configurations, the class decided to strongly consider single deck configurations. While these configurations will have some evacuation problems, they also will have structural, aerodynamic and passenger comfort advantages. As a result, all designs described in this paper will be single deck configurations.

## Wing Design

Wing design is driven by size constraints, imposed by existing aircraft terminal facilities, that limit the wing span of the aircraft. Consequently, it becomes important to consider the trades involved in wing design with the constraint of a fixed upper limit on the wing span.

The most important factor in controlling the induced drag is the wing span loading (the ratio of aircraft weight to wing span). With the span limited and the weight requirements high, one must look to new configurations. The wingspan constraint was addressed by using folding wing tips and multiple lifting surfaces, including tandem wings, canard configurations and three surface configurations.

Another key parameter in wing design is the choice of wing area. The cruise lift coefficient  $C_L$  is related to aircraft weight  $W$  and wing planform area  $S$  as follows

$$C_L = \frac{W/S}{q} \quad (4)$$

where  $q$  is the dynamic pressure. From a structural point of view the wing area should be small to decrease wing weight and empty weight. As  $W/S$  increases with decreasing wing area,  $C_L$  increases. This results in an increase of induced drag, which depends on the square of  $C_L$  as follows

$$C_{Di} = \frac{C_L^2}{\pi e AR} \quad (5)$$

where  $AR$  is the aspect ratio and  $e$  is Oswald's efficiency factor. As a result of increased induced drag, more fuel is required, so that the take-off gross weight increases even though wing weight decreases. The matter is further complicated by changes in the parasite drag as wing weight changes. Clearly there is an optimum trade-off between wing area, induced drag and fuel required.

This trade between wing area, weight, drag, and take-off gross weight exists for every type of aircraft. However, this trade is very evident in the mega-transport because of the large wing areas involved and the large take-off gross weights.

## Engines

Large transports must have efficient propulsion units. These engines must meet thrust requirements, noise

standards and emission standards. Although some long range aircraft such as the Boeing 777 are powered by twin engines, the "one engine out" requirement for the megatransport requires more than two engines. All teams chose to use four engines with relatively high bypass ratios so that they could meet noise constraints and have TSFC's of about 0.55 lb/lb./hr. at cruise. One group chose a prop-fan engine with very low fuel consumption.

The team design take-off gross weights (TOGW) for the aircraft designs range from slightly below one-million pounds to about 1.2 million pounds. Although there are some large engines that may meet the requirements for megatransport propulsion, the engines used on the Purdue designs were designed to meet the special requirements of their airplane. The cycle analysis programs ONX and OFFX, developed by Mattingly and Heiser,<sup>12</sup> were used for engine design and performance predictions.

Large engines create design problems over and above the usual problems of finding an efficient design cycle. The large intakes require severe restrictions on ground clearance. This leaves the designer with a choice of lengthening the landing gear, adopting a high wing design or mounting the engines on top of the wing.

In addition to these problems, FAR 36 and ICAO Annex 16 (Chapter 3) have restrictions on lateral, take-off and approach noise.<sup>13</sup> While these regulations permit increased noise with increased aircraft weight, the upper level of noise generation is fixed for aircraft weights greater than 900,000 pounds.

## Cost and Price Estimation

The megatransport must have low operating expenses compared to existing aircraft such as the B-747 aircraft. These operating expenses translate into direct operating cost (DOC) per block hour of operation and direct operating costs per available seat mile.

The estimation of direct operating costs requires an estimate of airplane cost and fuel requirements. The production costs to build the aircraft were estimated using the DAPCA IV model discussed by Raymer<sup>4</sup>. This model estimates cost on the basis of aircraft empty weight, production quantity, maximum airspeed and engine and avionics cost. One problem with this estimator is that it is based on a data base heavily weighted with military aircraft. Still, the numbers generated using this model are useful.

The price of the aircraft was calculated using a cash flow analysis. This calculation considers production cost (from the DAPCA model), quantity produced over a 19 year period and the cost of raising capital (effective interest rate on borrowed money and money raised in financial markets) to initiate the program. A low cost of capital (currently near 17%) is very important to the success or failure of a

commercial venture. The production quantity was set by the teams based on what the market would support.

Direct operating costs (DOC) were estimated using a model suggested by the Association of European Airlines. The direct operating costs and the cash flow analysis required to set the manufacturers selling price were calculated, using a computer model supplied by Professor J.W. Drake<sup>14</sup>. The input to the DOC model includes mission block time, fuel requirements, cost data for labor rates, fuel prices, engine prices, aircraft purchase price, maximum weight, stage length, payload and number of crew members.

### Design Resources and organization

Teams were composed of from 5 to 6 members, each with a primary responsibility. There were 4 such teams during the Fall 1992 semester and 5 teams during the Spring 1993 Semester.

The design course at Purdue is one semester long. This allows about ten weeks of group effort to produce a preliminary design after all the basic areas of effort are reviewed. In addition to the emphasis on technical effort, the requirements for communication in terms of writing quality and oral presentations are stressed.

### A Summary of Configurations

This section will present four representative 1992-93 team design efforts. These designs have been selected to illustrate the range of solutions developed. Each of these designs represents a different path taken by students. The reader should keep in mind that the final results at the end of one semester are at a preliminary level. At the close of a semester the students are finally aware of the trades and are aware of where they need more effort. On the other hand, for the most part, these efforts indicate a remarkable level of understanding and effort.

### The Phoenix 650

The design of the Phoenix 650 was selected and refined by its design team to be an unconventional answer to several problems and constraints posed by the RFP. This design, shown in Figure 1, uses the joined wing concept first suggested by Wolkovich. The team selected this configuration because they wanted a challenge and because they thought that this design would have lower wing weight, good transonic area distribution, low trim drag and better accessibility to existing airports. On the other hand, the team felt that the lack of a good data base for weight estimation and the challenges of doing a credible analysis were drawbacks for this selection.

The Phoenix 650 has an estimated empty weight of 505,000 lb. but has a take-off gross weight of only 750,000 lb. This low take-off gross weight is made possible by the

use of four prop fan engines with a TSFC of 0.286 lb/lb/hr. This remarkably low TSFC translates into a very low fuel weight.

This aircraft will carry 650 passengers. The length of the Phoenix 650 is 240 feet while the fuselage width is 30 feet

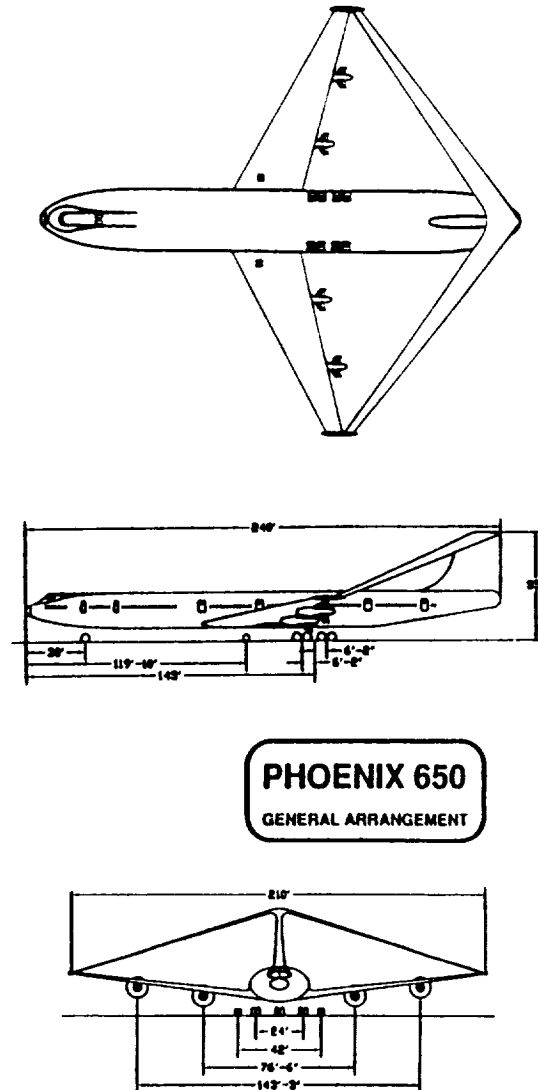

Figure 1 - The Phoenix 650

at its widest point and the fuselage height is 18 feet at the same point. The maximum L/D is estimated to be 22. The price of the aircraft is estimated to be \$140,000,000. The computer aided drawing effort for this aircraft was extremely good. A wind tunnel test model of the airplane is currently being manufactured by the Tupelov Design Bureau for delivery in September 1993 for testing.

### The BWB-650 Griffin

The BWB-650 Griffin is an ultra-wide body aircraft that attempts to use the minimum of trimming and stabilizing surfaces to reduce drag. This aircraft, shown in Figure 2, has a wing span of 300 feet and a total length of 209 feet. The wing tips can be folded so that they are only 230 feet wide in their folded position. The take-off gross weight of this aircraft is 985,000 lb. with an empty weight of 450,300 lb. The aircraft price is estimated to be \$134,500,000.

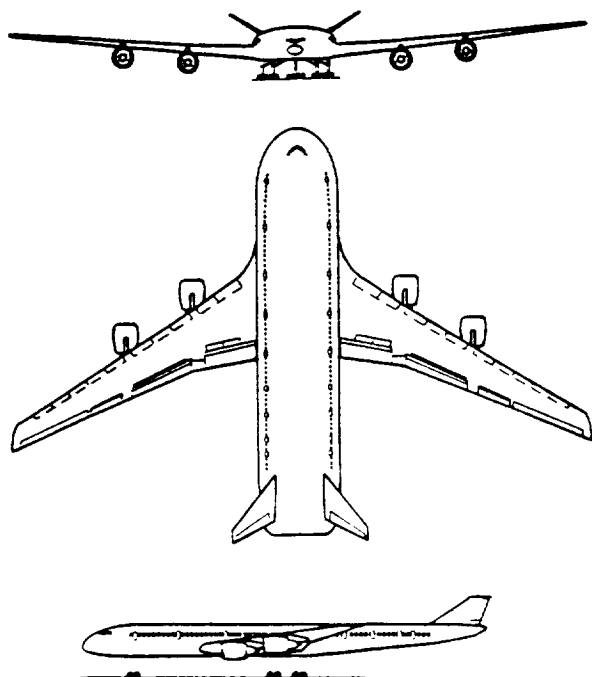

Figure 2 - The BWB-650 Griffin

The BWB-650 carries 657 passengers and has a fuselage that is 16 ft. 10 in. high and 42 ft. 2 in. at its widest point. The aircraft is powered by four high bypass ratio engines with a cruise TSFC of 0.546 lb./lb./hr. and a thrust of 81,600 lb. per engine at sea level static conditions. The maximum L/D was estimated to be 23.19 because of attempts to minimize wetted area and maximize wetted aspect ratio.

### The INF Super Condor

The INF Super Condor, shown in Figure 3, is a single deck, wing/canard lifting surface aircraft that can carry 656 passengers. With a maximum span of 220 feet, the relative areas of wing and canard, as well as their placement on the fuselage, were selected with the objective of high L/D and

low wetted area in mind. The maximum L/D of this configuration is estimated to be 19.

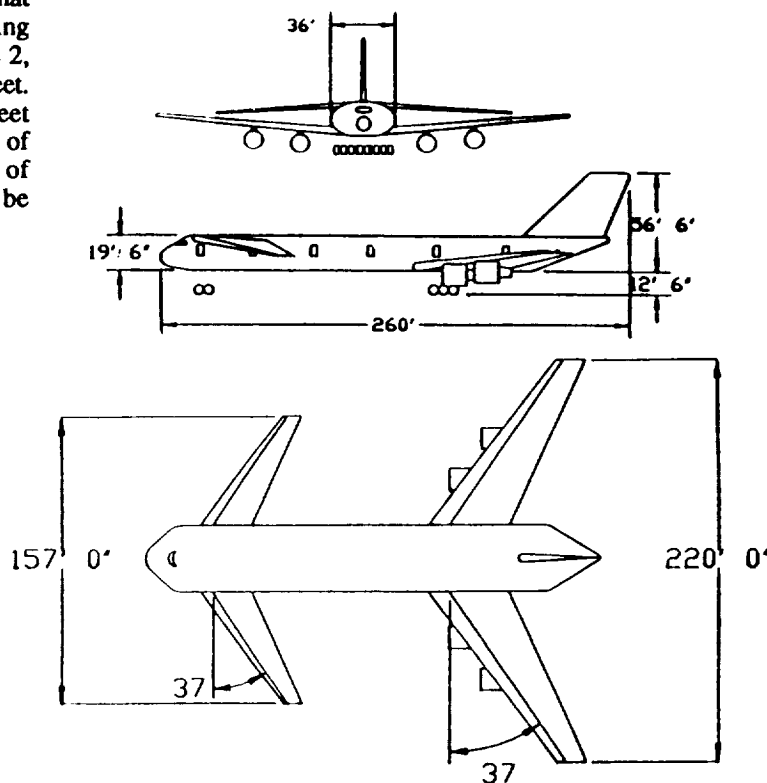

Figure 3 - The INF Super Condor

The thrust per engine is 81,000 lb. at static sea level conditions. TSFC at cruise is 0.534 lb./lb./hr. The take-off gross weight is 1,180,000 lb. with an empty weight of 539,000 lb. The price of this aircraft is estimated to be \$200,000,000. The length of the airplane is 260 ft. with a maximum fuselage width of 36 feet and a maximum height of 19 feet 6 inches.

### The AMT-Condor

The AMT-Condor, shown in Figure 4, is a conventional design, again with an ultra-wide deck. The AMT-Condor team chose this design because of their concern for configuration acceptability in the marketplace. This aircraft has a take-off gross weight of 1,137,000 lbs. and an empty weight of 480,400 lb. The wing span is 275 feet and the aircraft length is 240 feet. The fuselage cross-section, with a maximum width of 33 feet and a height of 16 feet 6 inches, should help lift generation. The maximum L/D is 19.

An indication of size and efficiency of each of these aircraft is provided by the data in Table 2.

Table 2 - Design OEW, wing span, TOGW

Aircraft	OEW (lbs)	wing span (ft)	TOGW (lbs.)
BWB-650	450,300	300/230	985,000
Phoenix 650	505,000	210	750,000
AMT-Condor	480,400	275	1,137,000
INF-Super Condor	539,000	220 (2-surface)	1,180,000

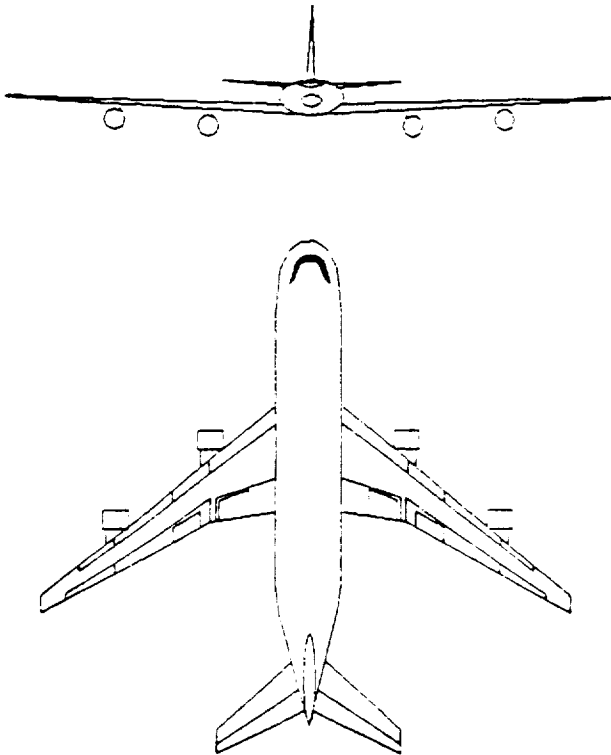

Figure 4 - AMT-Condor

**Fuselage Designs and Comparisons**

To the passenger, the heart of the transport aircraft is the fuselage. The aerodynamic efficiency, in terms of minimizing drag, requires a slender fuselage or no fuselage at all. One design considered initially by several groups was a flying wing. While aerodynamically efficient, the flying wing seats passengers in very wide rows. This makes it difficult to evacuate the aircraft in an emergency. It also makes it awkward to service the cabin in flight.

Fuselage designs finally centered on the single deck, "ultra-wide" configuration shown in Figure 5. Cargo storage is a design criterion, as is the ability to provide a carry-through structure. With so many passengers on board, internal traffic patterns must be considered. Also, the

requirements placed on a cargo hold to carry so much baggage are severe.

For pressurization loads there is no more efficient structural form than a circular cross-section. On the other hand, if the aircraft has two decks, then only about 1/3 of the large circular cylinder is filled with passengers. There are other related problems of increased height of the aircraft and increased landing gear length when a circular section is used.

Hitch<sup>15</sup> assesses the trades between a "flattened" elliptical section and a circular section and concludes that a slight weight penalty is necessary to use an elliptical section, but that this increased weight is more than made up by decreased wetted area and reduced drag. It is interesting to note that the

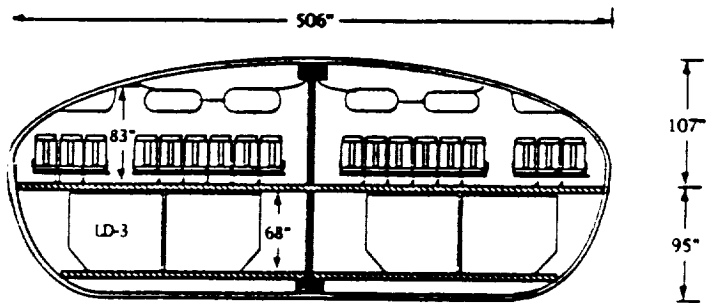

Figure 5 - Fuselage design (BWB-650 Griffin)

Tupelov Design Bureau will unveil its answer to the mega transport problem at the Paris Air Show in June 1993 and their design is rumored to be an ultra-wide-body.

**Engine Design**

Engine design is an integral part of the senior design course at Purdue. Each group was required to design an engine around a baseline engine provided to them. Design included the design of the engine cycle and included specifying the turbine inlet temperature, compressor pressure ratio and engine bypass ratio.

Engine design efforts were supported by the ONX and OFFX analysis programs mentioned earlier. The TSFC at cruise altitudes for turbo-fans ranged from a low of 0.52 to a high of 0.54. Bypass ratios between 8 and 10 were common. An alternative engine was proposed by the designers of the Phoenix 650. This engine was a prop-fan, shown schematically in Figure 6. This engine used the latest technology available and had a remarkably low estimated TSFC of 0.286 lb./lb./hr.

For the operator and the passenger, the fuselage is the heart of the airplane. However, for the engineer, it is the wing that makes or breaks the design. The wing design is affected by considerations of performance, such as landing,



take-off and cruise. On the other hand, the wing design must take into consideration added weight and the ability to house fuel and landing gear as well as carry engines.

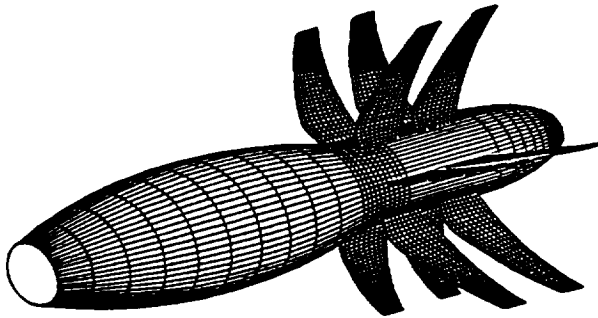

Figure 6 - Proposed prop-fan engine  
 (Oliver Debikey)  
 Aerodynamics

Most of the team designs used wing loadings near 130 lb. per square ft. This wing loading allows the aircraft to operate efficiently at cruise, however, at landing and take-off leading edge and trailing edge devices must be used to operate at the airfields specified in the RFP's.

The primary parameters for trade-off studies in wing design are airfoil thickness to chord ratio, wing area, sweep, taper ratio and aspect ratio. Wing placement on the fuselage is a consideration also. In the vertical plane of the design, the wing may be placed high on the fuselage, in the middle of the fuselage or low on the fuselage. There are advantages and disadvantages to all of these choices.<sup>16,17</sup>

The megatransport designs generated by the teams used a variety of wing mounting positions. The low wing position was popular. All teams used supercritical airfoils and some used laminar flow control.

#### Aircraft Cost and Price Analysis

Controlling aircraft price and cost of aircraft and the cost of operations are emphasized in our design course. Cost of production and cost of operation are computed to make sure that what is being designed is cost efficient.

If the number of aircraft produced is large, then the cost per aircraft and the price per aircraft will be low. On the other hand overestimating market share can be disastrous. To illustrate this, Figure 7 shows the cash flow (profit) after 19 years of production using our computer simulation. The discount rate or cost of capital is 12% (a low estimate considering the risk) while the aircraft empty weight is 450,000 lbs.

Plotted on the horizontal axis is the manufacturer's selling price. Note that the break-even price (where the cash flow is

zero) must increase substantially if the market share is reduced from 452 aircraft to 252 aircraft.

As noted previously, the market for this type of airplane is estimated to be about 550 units by 2010. On the other hand, a company cannot be expected to capture the entire market. Design teams estimated as few as 200 units and as many as 400 units that they could sell. As a result, the prices of the aircraft varied widely depending upon their empty weights, the estimates of the number to be produced and the cost of capital estimate used for calculations.

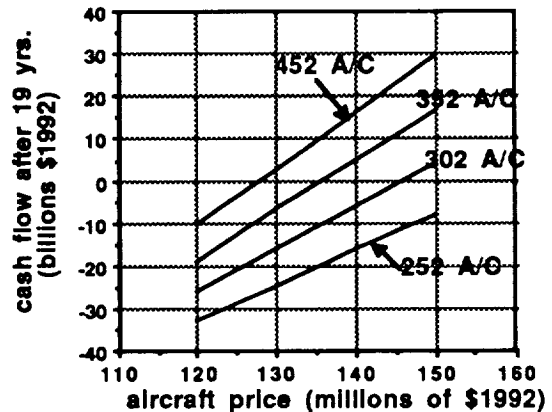

Figure 7 - Cash flow (profit) after 19 years of production vs. aircraft price; cost of capital 12%; empty weight 430,000 lbs.

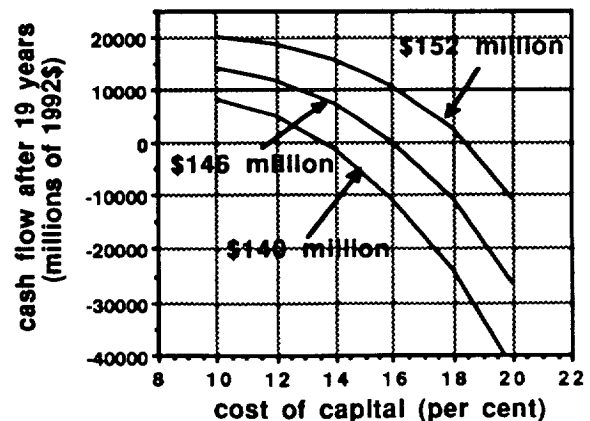

Figure 8 - The cash flow (profit) after 19 years of production vs. cost of capital at three different aircraft prices; 352 aircraft produced; empty wt. of 430,000 lbs.

Figure 8 shows the effect of cost of capital on cash flow after 19 years for three different manufacturers prices for an aircraft whose empty weight is 430,000 lbs. The production number is fixed at 352, including two test aircraft that are later sold.

From Figure 8 it is seen that financial market uncertainties, such as the increase of a few per cent in acquiring financial backing, can change a favorable return to an unfavorable return on an aircraft of this size.

### Conclusions and Recommendations

Purdue design classes considered the engineering and economic tasks of designing a megatransport aircraft with 650 passengers and 8000 nautical mile range.

Due to the emphasis placed upon the use of existing airport facilities, many airplanes were of unconventional design. The use of supercritical airfoils and composite materials was considered as methods of reducing weight. The result was decreased acquisition cost and operating costs.

As aircraft grow in size, the effects of the square-cube law on the structure demands a fresh look at advanced, integrated configurations. Most teams accomplished this task, but to differing degrees. The most interesting design feature promoted by the class was the ultra-wide fuselage discussed by Hitch.

In addition, reduced weight from advanced technology, even though risky from a maintenance standpoint, requires a look at concepts such as fly-by-wire and more advanced composite materials in the primary structure.

Finally, it must be noted that the last leap forward in size occurred two and one-half decades ago. This leap involved enormous risks, but was also enormously successful. This current leap will also require vision, daring, cooperation and skill.

### Acknowledgments

The opinions expressed in this paper are solely those of the authors and the students involved in this project. In addition, the authors recognize the individual and group efforts of the 55 students who participated in the project. The joys and sorrows involved with working with and teaching these students are what teaching is all about. To them - thanks for your efforts. We would also like to acknowledge the advice and estimation data provided by the Tupelov Design Bureau sponsored as part of Purdue University's globalization effort. Finally, we wish to acknowledge the support of NASA and USRA for funding provided as part of the Advanced Design Program and to Mr. Jack Morris, Langley Research Center, who provided advice and support.

### References

1. "Outlook for Commercial Aircraft 1991-2010," Douglas Aircraft Company, Market Assessment, Long Beach, California, January 1992.
2. "1992 Current Market Outlook - World Market Demand and Airplane Supply Requirements," Boeing Commercial Airplane Group, Seattle, Washington, February 1992.
3. "The Biggest Influence," Flight International, 28 October - 3 November 1992, pp. 26-30.
4. Raymer, D.P., *Aircraft Design: A Conceptual Approach*, American Institute of Aeronautics and Astronautics, Washington, D.C., 1989.
5. Cleveland, F.A., "Size Effects in Conventional Aircraft Design," *Journal of Aircraft*, Vol. 7, No. 6, Nov.-Dec. 1970.
6. Lange, R.H., "Review of Unconventional Aircraft Design Concepts," *Journal of Aircraft*, Vol. 25, No. 5, May 1988, pp. 385-392.
7. Mikolowsky, W.T., Noggle, L.W. and Stanley, W.L., "The Military Utility of Very Large Airplanes and Alternative Fuels," *Astronautics and Aeronautics*, September 1977, pp. 46-56.
8. Arata, W.H.Jr., "Very Large Vehicles - To Be ...?" *Astronautics and Aeronautics*, April 1979, pp. 20-33.
9. Noggle, L.W. and Jobe, C.E., "Large Vehicle Concepts" *Astronautics and Aeronautics*, April 1979, pp. 26-32.
10. Horonjeff, R. and McKelvey, F. X., *Planning and Design of Airports*, McGraw-Hill Book Company, New York, 1983.
11. Keith-Lucas, D. "Defeating the Square-Cube Law," *Flight International*, Vol. 94, No. 3106, Sept. 1968, pp.440-442.
12. Mattingly, J.D., Heiser, W.H., and Daley, D.H., *Aircraft Engine Design*, American Institute of Aeronautics and Astronautics, Washington, D.C., 1987.
13. Smith, M.J.T., *Aircraft Noise*, Cambridge University Press, Cambridge, England.
14. Drake, J.W., Course Notes: *AAE 210 - Introduction to Air Transportation*, School of Aeronautics and Astronautics, Purdue University, West Lafayette, Indiana, 1990.

15. Hitch, H.P.Y., "Pressure cabins of elliptic cross section," *Aeronautical Journal*, June/July 1988, pp. 207-223.

16. Roskam, J., *Airplane Design; Part II: Preliminary Configuration Design and Integration of the Propulsion System*, Roskam Aviation and Engineering Corporation, Ottawa, Kansas, 1989.

17. Torenbeek, E., *Synthesis of Subsonic Airplane Design*, Kluwer Academic Publishers, Dordrecht, Netherlands, 1982.

Other useful papers include:

Bohon, H.L. and Davis, J.G., Jr. , "Composites for large transports - facing the challenge," *Aerospace America*, June 1984, pp. 58-62.

Chuprun, J., Jr., "Large Aircraft, Requirements and Capabilities," AIAA Paper 84-2505, San Diego, Calif., 1984.

Lowrey, R.O., "Evolution of Large Transport Wings," AIAA Paper 80-3038, 1980

Robinson, D.L. and Melary, M.F., "Large Airplane Derivative Development Methodology," AIAA Paper 85-3043, 1985.

Sagdeo, P.M., "Very High Capacity Medium Range Passenger Transport," AIAA Paper 91-3079, Baltimore, Md. 1991.

Verginia, F.J., Barber, E.A. and Rettie, I.H., "Parametric Design and Analysis of Large Advanced Military Transports," AIAA Paper 76-924, Dallas, Texas, 1976.

**Special thanks to the following teams and team members:**

**AMT-Condor** - Ed Caperton, Rob Gillgrist, Martin Pesut, Jason, Scheuring, Dave Semanik

**BWB-Griffin** - Greg Bucci, Erika Pearson, Peggy Precup, Matt Szolwinski, Kent Wiechart, Chris Wright. (This team placed first in the 1993 Thiokol Technical Communication Competition).

**INF - Super Condor** - Matt Fisher, Angela Hare, Bill Huston, Dan McAninch, Brian Moore, Derek Wyler

**Phoenix 650** - Jerry Andrews, Eric Bates, Alonzo Brumfield, Jose Carrasco, Oliver Debikey, Brett Hoffstadt