

Evaluation of the Tribological Behavior of Krytox 143AB With Nano-Onions

Kenneth W. Street and Mario Marchetti
Glenn Research Center, Cleveland, Ohio

Randy L. Vander Wal and Aaron J. Tomasek
National Center for Microgravity Research, Cleveland, Ohio

The NASA STI Program Office . . . in Profile

Since its founding, NASA has been dedicated to the advancement of aeronautics and space science. The NASA Scientific and Technical Information (STI) Program Office plays a key part in helping NASA maintain this important role.

The NASA STI Program Office is operated by Langley Research Center, the Lead Center for NASA's scientific and technical information. The NASA STI Program Office provides access to the NASA STI Database, the largest collection of aeronautical and space science STI in the world. The Program Office is also NASA's institutional mechanism for disseminating the results of its research and development activities. These results are published by NASA in the NASA STI Report Series, which includes the following report types:

- **TECHNICAL PUBLICATION.** Reports of completed research or a major significant phase of research that present the results of NASA programs and include extensive data or theoretical analysis. Includes compilations of significant scientific and technical data and information deemed to be of continuing reference value. NASA's counterpart of peer-reviewed formal professional papers but has less stringent limitations on manuscript length and extent of graphic presentations.
- **TECHNICAL MEMORANDUM.** Scientific and technical findings that are preliminary or of specialized interest, e.g., quick release reports, working papers, and bibliographies that contain minimal annotation. Does not contain extensive analysis.
- **CONTRACTOR REPORT.** Scientific and technical findings by NASA-sponsored contractors and grantees.

- **CONFERENCE PUBLICATION.** Collected papers from scientific and technical conferences, symposia, seminars, or other meetings sponsored or cosponsored by NASA.
- **SPECIAL PUBLICATION.** Scientific, technical, or historical information from NASA programs, projects, and missions, often concerned with subjects having substantial public interest.
- **TECHNICAL TRANSLATION.** English-language translations of foreign scientific and technical material pertinent to NASA's mission.

Specialized services that complement the STI Program Office's diverse offerings include creating custom thesauri, building customized databases, organizing and publishing research results . . . even providing videos.

For more information about the NASA STI Program Office, see the following:

- Access the NASA STI Program Home Page at <http://www.sti.nasa.gov>
- E-mail your question via the Internet to help@sti.nasa.gov
- Fax your question to the NASA Access Help Desk at 301-621-0134
- Telephone the NASA Access Help Desk at 301-621-0390
- Write to:
NASA Access Help Desk
NASA Center for Aerospace Information
7121 Standard Drive
Hanover, MD 21076

NASA/TM—2003-212301

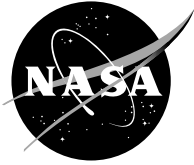

Evaluation of the Tribological Behavior of Krytox 143AB With Nano-Onions

Kenneth W. Street and Mario Marchetti
Glenn Research Center, Cleveland, Ohio

Randy L. Vander Wal and Aaron J. Tomasek
National Center for Microgravity Research, Cleveland, Ohio

National Aeronautics and
Space Administration

Glenn Research Center

April 2003

Acknowledgments

This work was supported by the Revolutionary Aeropropulsion Concepts subproject of the Propulsion and Power Project at the NASA Glenn Research Center. This work was also sponsored by a NASA NRA 99-HEDs-01 combustion award (RVW). Both funding sources are administered through NASA cooperative agreement NCC3-975 with the National Center for Microgravity Research on Fluids and Combustion at the NASA Glenn Research Center. The authors gratefully acknowledge Gordon M. Berger for assistance with the experiments and Dr. Y. L. Chen and Mr. David R. Hull for the TEM imaging.

This report contains preliminary findings, subject to revision as analysis proceeds.

Trade names or manufacturers' names are used in this report for identification only. This usage does not constitute an official endorsement, either expressed or implied, by the National Aeronautics and Space Administration.

The Propulsion and Power Program at NASA Glenn Research Center sponsored this work.

Available from

NASA Center for Aerospace Information
7121 Standard Drive
Hanover, MD 21076

National Technical Information Service
5285 Port Royal Road
Springfield, VA 22100

Available electronically at <http://gltrs.grc.nasa.gov>

Evaluation of the Tribological Behavior of Krytox 143AB With Nano-Onions

Kenneth W. Street and Mario Marchetti
National Aeronautics and Space Administration
Glenn Research Center
Cleveland, Ohio 44135

Randy L. Vander Wal and Aaron J. Tomasek
National Center for Microgravity Research
Cleveland, Ohio 44135

Abstract

Nanoparticles have been widely developed over the past ten years and have found several applications. This work presents the use of carbon nano-onions, i.e. nanoparticles, as a potential additive in an oil for aerospace application. It was shown that these particles can provide adequate lubrication very similar to graphitic material.

I. Introduction

Soot, carbon material, represents one of the very first nanostructured materials, although it has rarely been considered as such. Soot has not been observed to differ substantially among laboratory-scale systems, a likely consequence of similarity in production conditions [1] and use of common hydrocarbons [2]. However, careful examination of the internal structure of these carbon materials reveals that the structure is highly variable and depends upon the starting material and processing conditions. Similarly, the nanostructure of carbon black also depends upon the reaction process [3].

The significance with respect to degradation of the internal structure of carbon is its effect upon reactivity. In general, more graphitic carbons are less prone to degradation, which primarily occurs through oxidation, though other such reactions may also occur [4]. Graphitic carbons are characterized by layer planes with large in-plane dimensions [5]. The connection between layer plane dimensions and oxidation is due to the anisotropic reactivity of the graphitic segments comprising the carbon. Carbon atoms within basal plane sites, surrounded by other carbon atoms, exhibit a far lower oxidative reactivity than those located at the periphery of such segments (so-called edge sites) [6]. Thus, by virtue of geometry, larger layer planes contain fewer carbon atoms at edge sites relative to basal plane sites. For these reasons, processes that induce growth of layer planes will necessarily affect the carbon's reactivity.

Changes in the carbon nanostructure, resulting in increased graphitic layer plane length, are correlated with reactivity loss [7]. Layer plane segments can grow by bonding to adjacent graphene segments and by addition of amorphous carbon material within the soot particle from which they are produced [8]. Whether thermally or oxidatively induced, an increase in the dimensions of graphene segments corresponds to graphitization and a parallel decrease in reactivity. Upon heating spherically shaped carbon black of nanometer scale dimensions in the absence of oxidant, graphene

sheets form and the initial soot particle templates the growth of a graphitic particle into what is best described as a "sphere" with many flat sides, i.e. polygonal in nature and having a hollow interior. Due to the absence of edge sites, these polygonal graphitic particles, or nano-onions, are relatively stable toward oxidation [9, 10].

Graphite is used as a solid lubricant due to its stability at moderately high temperatures. However, the temperature at which the graphite rapidly degrades is strongly influenced by surface area [11]. With the size of particles typically employed in lubrication, a great amount of thermal stability is lost due to size reduction either during grinding for application or during lubrication of contacting parts. For this reason, we have undertaken a study of the lubricating ability of nano-structured graphitic particles, nano-onions.

The lubrication role of solid particles introduced in a fluid lubricant, generally MoS₂ in greases, depends on the size of the particles, on their amount, and on the geometry of the contact. The introduction of small particles is beneficial in boundary lubrication, when the lambda ratio (film thickness vs. surface roughness) is below 0.3 on the Stribeck [12] lubrication curve, i.e. the lubricant film is not separating the surfaces in contact. The particles present in the lubricant have to be of small size so as to allow a good fluid circulation within the contact and not to "jam" it. The amount of particles is generally low, a few percent in volume, and up to 10% for graphite [13]. Under severe conditions, these particles can produce a layer which helps to protect the surfaces [13–15].

The objective of this work was to evaluate the ability of graphitic nanospheres to improve the lubricating lifetime of the oil Krytox 143AB. A Spiral Orbit Tribometer (SOT) was used to evaluate the lifetime.

II. Materials and experiments

1. Methods of characterizing the nano-onions

Samples of carbon black (Cabot R250 from Cabot Corporation) were heat-treated in a resistance heated furnace using a graphite crucible under a He atmosphere. The nano-onions were obtained by inductive heating at 3000 °C for 1 hr. duration and were used without further treatment (e.g. purification). These materials were subjected to Thermo Gravimetric Analysis, TGA, and spectroscopic analysis.

Transmission electron microscope (TEM) images were taken using a Phillips CM200 with Gatan image filter (GIF) for digital imaging with live Fourier transforms having nominal resolution of 0.14 nm. The instrument operated at 200 keV using a LaB₆ filament. Gatan image software, v.3.4 was used for microscope operation.

2. Presentation of the Spiral Orbit Tribometer and preparation of the samples

A Spiral Orbit Tribometer (SOT) [16] simulates an angular contact bearing (fig 1). A 12.7 mm (1/2 inch) ball was rolled between a fixed plate and a rotary plate, running at 210 rpm. The load, providing a mean Hertz stress of 1.5 GPa, was applied through the fixed plate. The combination of the high load, the moderate speed, and of the small amount of lubricant (approximately 50 µg) allowed the system to operate in the boundary lubrication regime. The ball was rolling and pivoting in a spiral and maintained in the orbit by the guide plate. The force the ball exerted on the guide plate was used to determine the friction coefficient, since the ball was sliding between the disks at this moment. The resistance of the contacts between the ball and the plates was calculated from the voltage drop across the plates. The evaluation of the greases was conducted at

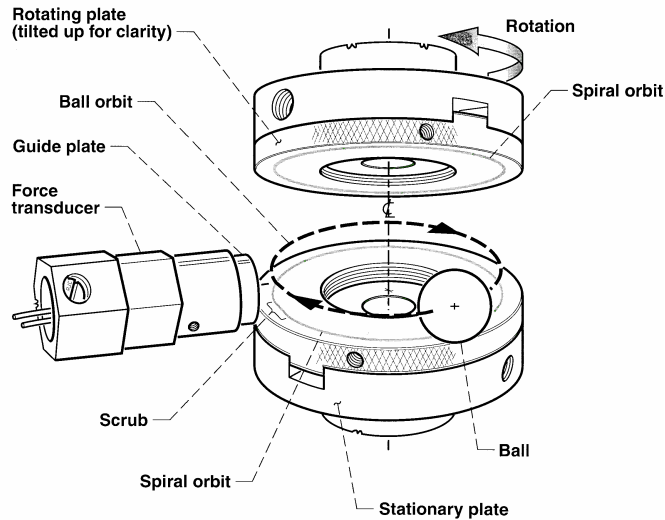

Figure 1.—The Spiral Orbit Tribometer

room temperature ($\approx 23\text{ }^{\circ}\text{C}$), and under ultrahigh vacuum ($1.3 \cdot 10^{-6}\text{ Pa}$) or in air. As the lubricant was tribologically stressed, it was degraded and eventually consumed. Test conclusion was defined when a friction coefficient of 0.28 was attained. Normalized lubricant lifetime (or inversely, its degradation rate) was then defined as the number of orbits divided by the amount of lubricant in micrograms.

All specimens were made of AISI 440C stainless steel. For tribological purposes, ball and plate surfaces were polished to a roughness, R_a , of $0.05\text{ }\mu\text{m}$. The parts were first rubbed with an alumina slurry and rinsed under running deionized water. Then they were ultrasonically cleaned for ten minutes each first in a bath of hexane, followed by deionized water. All drying was done with filtered nitrogen. The procedure was completed by exposing the specimens to ultraviolet/ozone for 15 minutes [17].

A solution of Krytox 143AB oil, already used in space applications, in Freon was prepared. It consisted of 10.33 mg of oil and 5.16 ml of solvent. Therefore, when $25\text{ }\mu\text{l}$ of the dilute solution was applied with a microsyringe on the ball, $50\text{ }\mu\text{g}$ of oil was left after evaporation of the solvent, $50\text{ }\mu\text{l}$ would leave $100\text{ }\mu\text{g}$, etc. The nano-onion particles were added in such a quantity that roughly a 20% (by weight) suspension was created. It corresponded to a nano-onion mass of 2.05 mg. A quick visual observation showed that the particles were agglomerated. So as to have a proper suspension, the dilute solution of oil, particles, and solvent was put in an ultrasonic bath for one minute before use. The solution was completely black. A ball was then lubricated with the dilute suspension and observed with a Raman spectrometer. The analysis revealed the presence of nano-onions particles on the surface of the ball.

3. Analytic techniques and post mortem analysis

All Infrared spectra were collected with a Nicolet “Magna 760”[®] FTIR spectrometer with a DTGS (deuterated triglycine sulfate) detector mounted within a 3 inch diameter gold coated Lab Sphere[®] integrating sphere. The sample was mounted in the sphere on a gold plated stand located in the reflectance position. The sample holder contained a 3/8 inch hole such that the ball mounted in the hole was centered in the light beam. Spectra were acquired between 400 and at least 4000 cm^{-1} at 4 cm^{-1} resolution vs. the gold from the sphere in reference mode. Between 100 and

250 scans were typically averaged and the spectra were further corrected to remove water vapor absorption bands and baseline curvature.

A Renishaw Model 2000 Raman Microscope that uses a 25 mW Ar Ion laser operating at 514.5 nm was employed to collect Raman spectra. Spectra were acquired in scan mode from 400 to 4000 cm^{-1} using an integration time typically between 20 to 100 seconds. The microscope objective employed was typically 20X with occasional spectra taken at 10X or 50X having spot diameters of 14, 28 and 5 microns respectively. The spectra presented here are single background corrected scans with minimal fourier transform smoothing. Spectra were taken from at least three areas of each sample or ball to ensure that the spectra are representative.

III. Results and Analysis

1. Nano-onion characterization

High resolution TEM images of the starting material, carbon black (fig 2b), and the nano-onions (fig 2a) indicate the significant change in structure of the material upon graphitization. In these images, the dark lines indicate the graphene sheets of carbon atoms and the white lines are the spacing between sheets. The annealing process allows ordering of the sheets and length extension of the flat crystalline regions resulting in considerable basal plane sites of low reactivity toward oxidation. The polygonal connection of basal planes eliminates edge sites to further reduce reactivity. While we have not measured the size distribution of the graphitized materials, the primary particle size, initially around 30 nm in diameter, is conserved in the graphitization process.

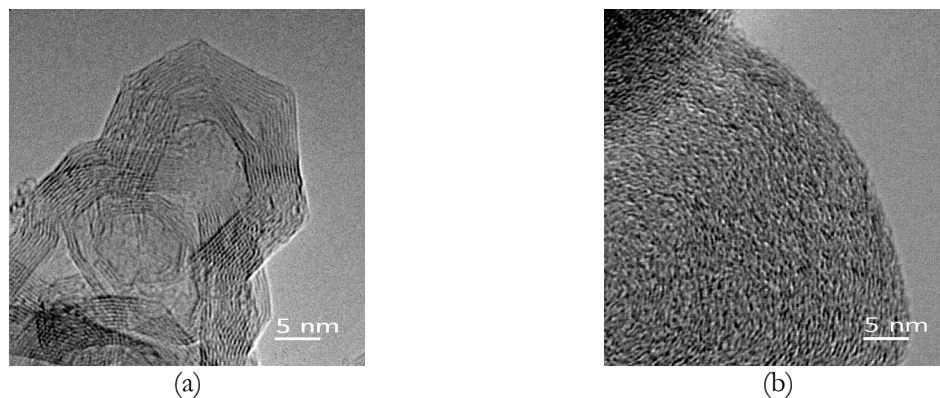

Figure 2.—TEM pictures of (a) nano-onions and (b) carbon black (Cabot R-250)

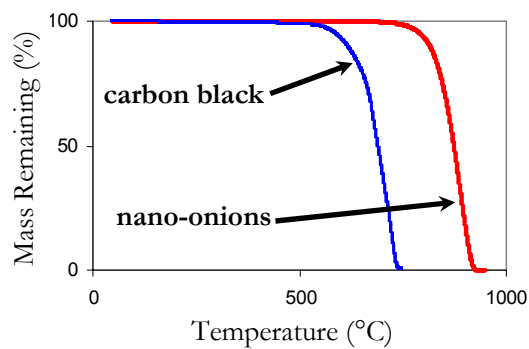

Figure 3.—Comparative TGA analysis of nano-onions and carbon black (Cabot R-250) at 10 °C/minute

The TGA analyses of the nano-onions and carbon black in air both indicate high purity materials having normal TGA profiles (fig 3). The point at which 5% of the materials are oxidized indicates the approximate temperature where rapid oxidation of these materials proceeds. For the carbon black, this temperature is 588 °C and for the nano-onions 792 °C at 10 °C/minute indicating the improved oxidation resistance of the graphitic nanostructured material.

Raman spectroscopy has been frequently used in the examination of graphite and graphitic materials. Two spectral peaks characterize the first order Raman spectra of carbon materials (fig 4a) a peak near 1580 cm^{-1} (E_{2g} or “G”) and a peak near 1360 cm^{-1} (A_{1g} or “D”) [18]. The former corresponds to an in-plane stretching motion of the graphitic layer planes. The latter arises from a breakdown of the Raman selection rules attributed to the finite-sized regions of graphitic structure (hence its nomenclature as the “disorder activated” transition). Several measures have been applied to the spectra that have been correlated with the extent of graphitic structure, such as line-width, peak positions and peak intensity ratios [19]. The intensity ratio of these peaks has been interpreted as a measure of the in-plane crystallite dimensions [9, 20]. The narrowing of the D and G peaks indicates increasing homogeneity of the sample as disordered carbon is reorganized into graphitic sheets. The spectra obtained from the nano-onions contained sharp D and G peaks with the G peak much more intense indicating a highly ordered material considerably different from the starting carbon black. In addition, the second order region between 2385 and 2360 cm^{-1} contains a sharp, intense band at 2696 cm^{-1} for highly ordered graphitic materials, like the nano-onions. This band is virtually absent in the degradation products and the starting carbon black [21].

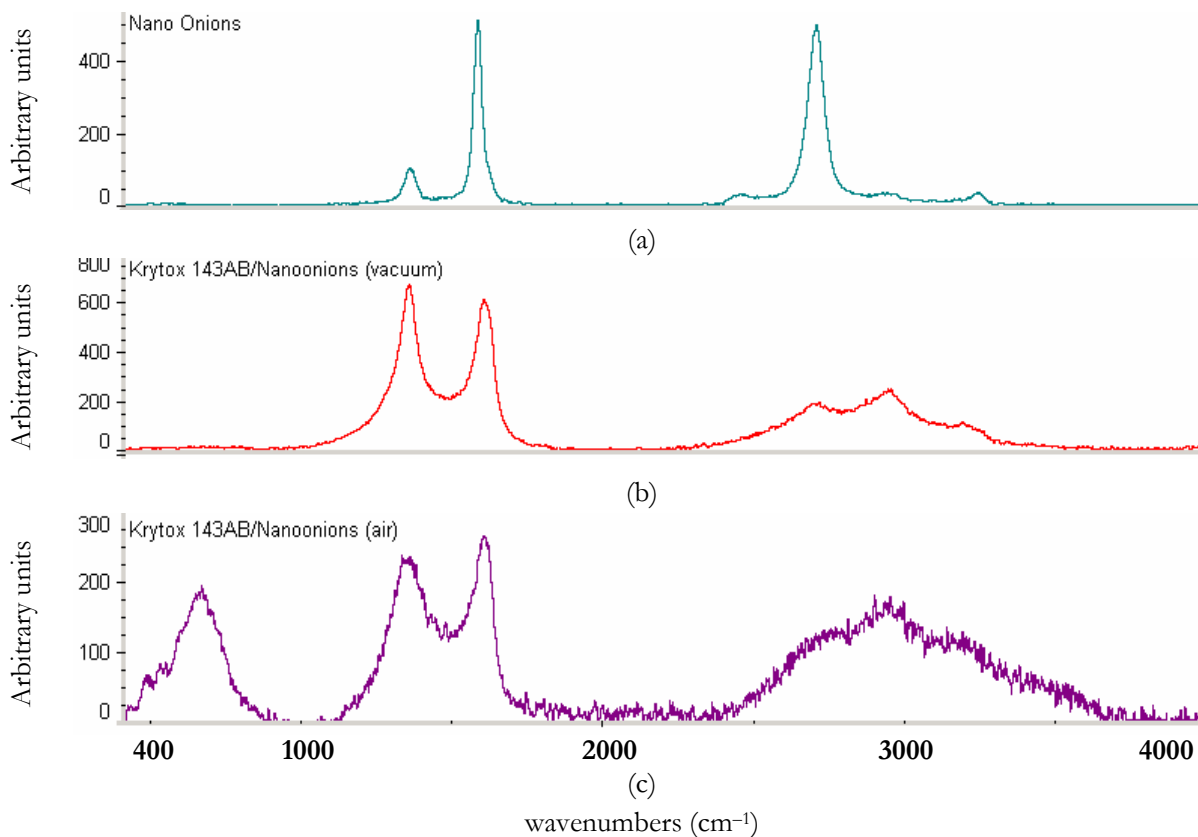

Figure 4.—Raman spectra of the nano-onions

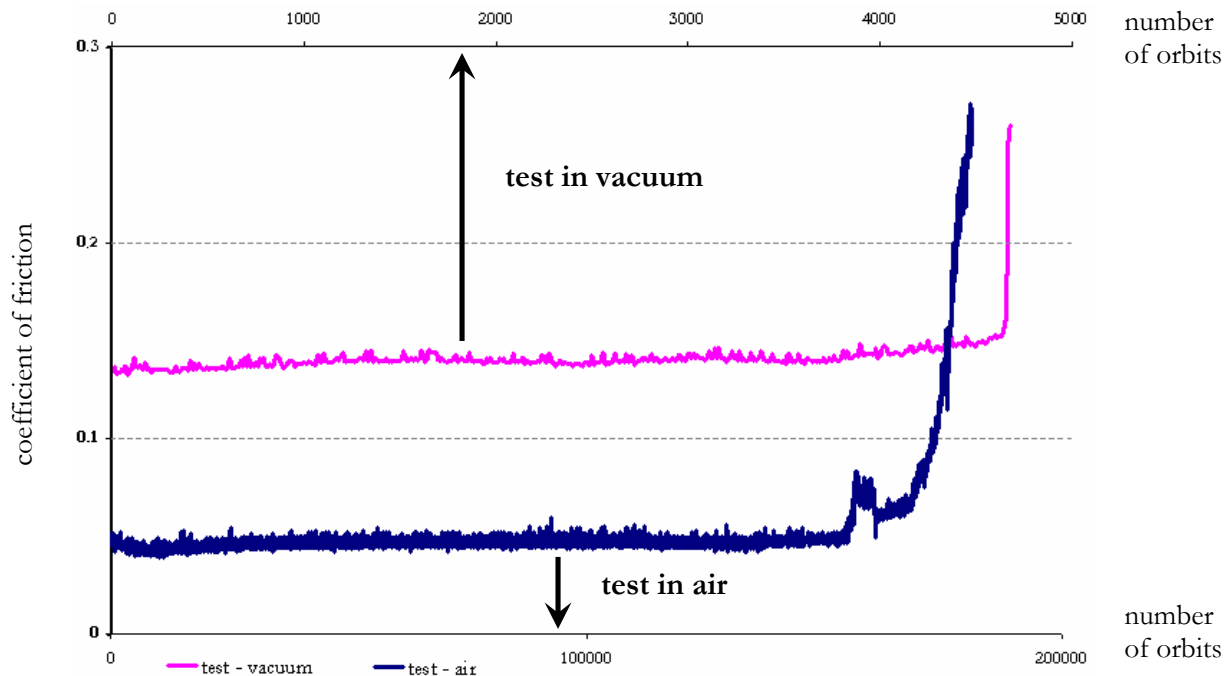

Figure 5.—Friction coefficient for tests run in vacuum (upper scale) and in air (lower scale) with Krytox 143AB with nano-onions

Table 1.—Normalized lifetimes (number of orbits per μg of lubricant used) of Krytox 143AB with nano-onions for different atmospheres

	test 1	test 2	average
vacuum	20	90	55
air	2383	5278	3830

2. Tribological response

a. Tests in vacuum

Two tests were conducted in ultrahigh vacuum, at room temperature. The average of the normalized lifetime (number of orbits performed before failure per microgram of lubricant employed, i.e. oil and nano-onions) was calculated. Examples of friction traces and the lifetime obtained are given in fig 5 and Table 1 respectively. The use of nano-onions did not improve the lifetime, nor did it change the friction coefficient of this PFPE oil run in vacuum [22].

b. Tests in air

Two tests were also conducted in air, at room temperature. Results are reported in fig 5 and Table 1. A very low friction coefficient (0.04 to 0.05) was observed with a long lifetime. Furthermore, the failure is more “progressive” compared to the one observed in vacuum.

3. Spectroscopic analysis

Raman analysis on the balls run in vacuum (fig 4b) indicated the presence of a large quantity of graphitic material having well defined D (1341 cm^{-1}) and G (1592 cm^{-1}) peaks as well as multiple small peaks in the second order peak region ($2520\text{ to }3300\text{ cm}^{-1}$). These spectra are not similar to the applied nano-onions but of conventionally degraded lubricants. It should be noted that we have

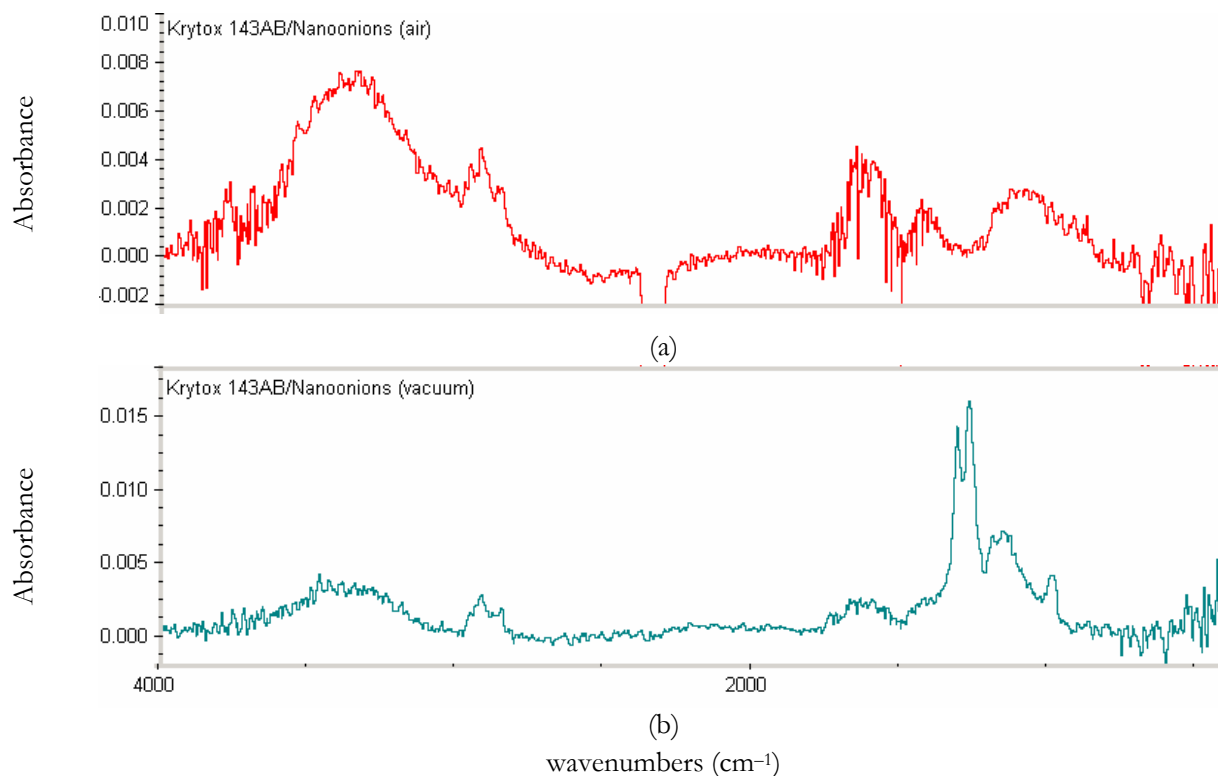

Figure 6.—Infrared spectra of the Krytox 143AC with nano-onions after the tests run in air and vacuum

evidence that the nano-onions degrade to produce similar spectra so it is not possible to distinguish the source of the degraded material. The ball run in air (fig 4c) had similar spectral features but at much lower concentrations. Additionally, a moderate, broad unidentified peak occurred at 694 cm^{-1} in all spectra for the balls run in air.

Infrared analysis was performed postmortem on the balls (fig 6). Both types of balls showed hydrocarbon peaks in the $2960\text{ to }2850\text{ cm}^{-1}$ range and a broad band in the 3360 cm^{-1} range. These bands correspond to hydrocarbon and oxygenated materials respectively. No further evidence of oxygenated functional groups was found in either spectrum. The ball run in vacuum (fig 6b) revealed traces of material resembling the original Krytox 143AB having bands in the $1346\text{ to }970\text{ cm}^{-1}$ region of the spectrum. This result is unusual since all such material is typically consumed during an SOT experiment.

IV. Discussion

No improvement of the lifetime was observed in vacuum, neither in the lifetime, nor in the friction coefficient (fig 5, upper scale). Under conditions close to the ones of our experiments, a similar PFPE oil, Krytox 143 AC, conducted to a normalized lifetime of nearly $73\text{ orbits}/\mu\text{g}$ of lubricant [22]. It is thus concluded from the Raman analysis that the nano-onions degrade during tribological contact and that they are completely consumed at failure. In the vacuum experiments, no advantage is gained with the nano-onions and at failure, material resembling Krytox 143 AB

remains on the ball. In air however, a significant improvement in lifetime occurs (fig 5, lower scale) attributed to the nano-onions, which arises from their ability to serve as a back-up lubricant. Postmortem analysis indicates that the nano-onions are sacrificed to form a graphitic layer once the oil is tribologically degraded. This behavior is typical of graphite which requires humidity to act as a lubricant.

Due to the small size of the nano-onions, it is anticipated that they possess significant surface area. The degradation temperature of graphite in oxygen has been correlated to surface area, the greater the area the lower temperature at which oxidation occurs [11]. The nano-onions appear to be quite stable in air although it is not possible to correlate the TGA data for the nano-onions with those of graphite run in an oxygen atmosphere.

V. Conclusion

1. The nano-onions provide lubrication similar to graphite
2. The nano-onions degrade to a final material characteristic of the degradation of other carbon-based lubricants.
3. The nano-onions are stable in air to over 750 °C. This stability of the small particles is attributed to the lack of edge sites vulnerable to oxidation.
4. These nano-structured materials are of the correct particle size range to allow adequate circulation of lubricants such as Krytox but to still provide back-up lubrication under extreme conditions. These results suggest that the nano-onions could also be used as a solid additive to grease replacing MoS₂ in several commercially available lubricants for use in air.

VI. References

- [1] C.K. Law and G.M. Faeth, *Prog. Energy Combust. Sci.* 20 (1994) 64.
- [2] I. Glassman, *The Twenty-Second International Symposium on Combustion* (The Combustion Institute, Pittsburgh, 1988) 295.
- [3] J.B. Donnet, R.C. Bansal and M.-J. Wang, *Carbon Black Science and Technology*, 2nd ed. (Marcel Dekker, Inc., New York, 1993).
- [4] J.M. Thomas, in: *The Chemistry and Physics of Carbon*, Vol.1, ed. P. L. Walker, Jr., (Marcel Dekker, Inc., New York, 1965) Ch. 2.
- [5] H. Marsh, *Introduction to Carbon Science* (Butterworth, London, 1989) Ch. 4.
- [6] D.E. Rosner and H.D. Allendorf, *AIAA Journal* 6 (1968) 650.
- [7] K.A. Davis, R.H. Hurt, N.Y. Yang and T.J. Headley, *Combust. and Flame* 100 (1995) 31.
- [8] W.M. Hess, L.L. Ban, F.J. Eckert and V. Chirico, *Rubber Chem. and Technol.* 41 (1968) 56.
- [9] R.L. Vander Wal, A.J. Tomasek, K.W. Street and W.K. Thompson, "Carbon nanostructure examined by lattice fringe analysis of high resolution transmission electron microscopy images," *Environmental Science and Technology*, in review. NASA TM 2003-212214
- [10] R.L. Vander Wal, unpublished results (2002–2003).
- [11] E.R. Braithwaite, *Solid Lubricants and Surfaces* (Pergamon Press, New York 1964) Ch. 5.

- [12] W.A. Glaeser, *Characterizations of Tribological Materials* (Butterworth-Heinemann, Boston, 1993) pp. 1–13.
- [13] G.T.Y. Wan and H.A. Spikes, *STLE Transactions* 31(1) (1988) 12.
- [14] R. Holinski, *Eurogrease* (1992) 26.
- [15] F. Wunsch, *NLGI Spokesman* 54(1) (1991) 12.
- [16] S.V. Pepper, E.P. Kingsbury, *Tribology Transactions* 46(1) (2003) 57.
- [17] M.J. Jansen, W.R. Jones, R.E. Predmore and S.L. Loewenthal, “Relative Lifetimes of Several Space Liquid Lubricants Using a Vacuum Spiral Orbit Tribometer,” *Proc. 2nd World Tribology Congress, Vienna, 2001*.
- [18] E. Tuinstra and J. Koenig, *J. Chem. Phys.* 53 (1970) 1126.
- [19] D.B. Fischbach and M. Couzi, *Carbon* 24 (1986) 365. (and references therein).
- [20] D.S. Knight and W.B. White, *J. Mater. Sci.* 4 (1989) 385.
- [21] H. Hiura, T.W. Ebbsen, K. Tanigaki and H. Takahashi, *Chem. Phys. Lett.* 202(6) (1993) 509.
- [22] S.V. Pepper and E.P. Kingsbury, *Tribology Transactions* 46(1) (2003) 65.

REPORT DOCUMENTATION PAGE			<i>Form Approved</i> <i>OMB No. 0704-0188</i>	
Public reporting burden for this collection of information is estimated to average 1 hour per response, including the time for reviewing instructions, searching existing data sources, gathering and maintaining the data needed, and completing and reviewing the collection of information. Send comments regarding this burden estimate or any other aspect of this collection of information, including suggestions for reducing this burden, to Washington Headquarters Services, Directorate for Information Operations and Reports, 1215 Jefferson Davis Highway, Suite 1204, Arlington, VA 22202-4302, and to the Office of Management and Budget, Paperwork Reduction Project (0704-0188), Washington, DC 20503.				
1. AGENCY USE ONLY (Leave blank)		2. REPORT DATE April 2003	3. REPORT TYPE AND DATES COVERED Technical Memorandum	
4. TITLE AND SUBTITLE Evaluation of the Tribological Behavior of Krytox 143AB With Nano-Onions			5. FUNDING NUMBERS WBS-22-708-87-14	
6. AUTHOR(S) Kenneth W. Street, Mario Marchetti, Randy L. Vander Wal, and Aaron J. Tomasek				
7. PERFORMING ORGANIZATION NAME(S) AND ADDRESS(ES) National Aeronautics and Space Administration John H. Glenn Research Center at Lewis Field Cleveland, Ohio 44135-3191			8. PERFORMING ORGANIZATION REPORT NUMBER E-13872	
9. SPONSORING/MONITORING AGENCY NAME(S) AND ADDRESS(ES) National Aeronautics and Space Administration Washington, DC 20546-0001			10. SPONSORING/MONITORING AGENCY REPORT NUMBER NASA TM-2003-212301	
11. SUPPLEMENTARY NOTES Kenneth W. Street and Mario Marchetti, NASA Glenn Research Center; Randy L. Vander Wal and Aaron J. Tomasek, National Center for Microgravity Research, Cleveland, Ohio 44135. Responsible person, Kenneth W. Street, organization code 5960, 216-433-5032.				
12a. DISTRIBUTION/AVAILABILITY STATEMENT Unclassified - Unlimited Subject Category: 25 Available electronically at http://gltrs.grc.nasa.gov This publication is available from the NASA Center for AeroSpace Information, 301-621-0390.			12b. DISTRIBUTION CODE	
13. ABSTRACT (Maximum 200 words) Nanoparticles have been widely developed over the past ten years and have found several applications. This work presents the use of carbon nano-onions, i.e. nanoparticles, as a potential additive in an oil for aerospace application. It was shown that these particles can provide adequate lubrication very similar to graphitic material.				
14. SUBJECT TERMS Perfluoropolyalkylether; Carbon nano-onions; Spiral orbit tribometry; Tribology; Nanoparticles; Nanostructure; Raman spectroscopy			15. NUMBER OF PAGES 15	
			16. PRICE CODE	
17. SECURITY CLASSIFICATION OF REPORT Unclassified	18. SECURITY CLASSIFICATION OF THIS PAGE Unclassified	19. SECURITY CLASSIFICATION OF ABSTRACT Unclassified	20. LIMITATION OF ABSTRACT	