

2002

NASA FACULTY FELLOWSHIP PROGRAM

**MARSHALL SPACE FLIGHT CENTER
THE UNIVERSITY OF ALABAMA**

METAL CUTTING THEORY AND FRICTION STIR WELDING TOOL DESIGN

Prepared By:	Lewis N. Payton
Academic Rank:	PhD
Institution and Department:	Auburn University College of Engineering Lewis.Payton@eng.auburn.edu
NASA/MSFC Directorate:	Engineering (ED-33)
MSFC Colleague:	Dr. Arthur C. Nunes, Jr.

Introduction

Friction Stir Welding (FSW) is a relatively new industrial process that was invented at The Weld Institute (TWI, United Kingdom) and patented in 1992 [12] under research funded by in part by the National Aeronautics and Space Administration (NASA). Often quoted advantages of the process include good strength and ductility along with minimization of residual stress and distortion. Less well advertised are the beneficial effects of this solid state welding process in the field of occupational and environmental safety. It produces superior weld products in difficult to weld materials without producing any toxic fumes or solid waste that must be controlled as hazardous waste. In fact, it reduces noise pollution in the workspace as well.

In the early days of FSW, most welding was performed on modified machine tools, in particular on milling machines with modified milling cutters. In spite of the obvious milling heritage of the process, the techniques and lessons learned from almost 250 years of successful metalworking with milling machines have not been applied in the field of modern Friction Stir Welding. The goal of the current research was to study currently successful FSW tools and parameterize the process in such a way that the design of new tools for new materials could be accelerated. Along the way, several successful new tooling designs were developed for current issues at the Marshall Space Flight Center with accompanying patent disclosures

Survey of the Literature and Process

In order to visualize the process, consider Figure 1. The two materials to be welded are placed in contact via either an overlapping or in this case butt joint fashion. A broad tool with a narrower pin on the end is fabricated. The tool is then inserted while rotating at a high speed into the material until the wider “shoulder” of the tool makes contact with the material being welded. At this point, the tool begins a traverse of the weld seam, deforming the material in its passage, leaving behind a formed weld. The material does not melt during this solid-state deformation. Personnel with shop experience will recognize similarities with a type of end-milling referred to as slot-milling. Many rotary machines can be adapted to this process.

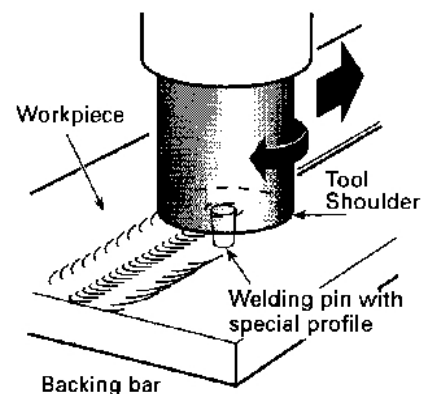

Figure 1. Basic FSW Process

Figure 1 details only the most basic concept of what can be a much more complex system of tooling. A comprehensive literature review of conference papers, referred papers, United States and international patents was performed. Copies of all the papers were provided to key NASA personnel along with an up to date listing of patents. A detailed bibliography and a copy of the patent listing (some 600 plus items) is prohibited in this summary article.

The review process indicated a general lack of standardization, documentation and systematic evaluation in the area of friction stir welding. This is due in part to the proprietary nature of TWI's patents, the relative newness of the process and a lack of instrumentation in the early

development stages. The level of instrumentation available was often minimal leading to a great deal of speculative operator changes based upon tradition and/or lore. The driving motive in such changes was the correlation of a perceived change with an improvement in final weld, as judged by “faster” process time, greater tensile or bending strength. These are at best indirect correlations with the true physical processes. Additionally, many of the papers are in non-refereed conference proceedings, which slows academic research in the field.

The best attempts to quantify the mechanics of the process to date have been conducted at the University of South Carolina [8, 9] and NASA. The most detailed paper of the flow patterns is a “seminal” paper by Kevin Colligan [2]. Efforts to document and characterize material properties of the weld at University of Texas El-Paso have been most notable [5, 6]. Numerous models have been proposed ([7]) . The best tool studies to date are proprietary by The Welding Institute, although none of the modelers take into account the eccentric tool path. Classic milling theory offers simple solutions for the FSW tool designer.

An Application of Milling Theory

Figure 2a depicts what machining theory in general refers to as up milling and down milling. Figure 2b shows the FSW terminology for these as Leading (up-milling against the tool) and Trailing (down-milling with the tool). On the leading (up-milling side), as the tool enters the work, tool tip velocity V assumes a maximum value, which decreases as the tool progresses along the tool path. On the trailing side, V has a minimum value when the tooth leaves the work and a somewhat higher value when the tool enters the work. The tool edge traces out a looped tracheiod path through the material, as well explained by Martellotti [3, 4].

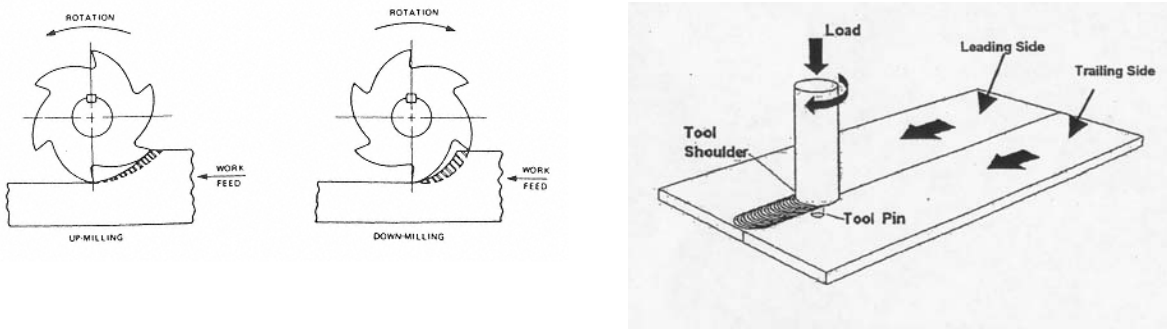

Figure 2A. Up-milling and Down-milling

Figure 2B. Leading and Trailing Sides

Silin [1, 11] introduced the use of similarity numbers for use in metal cutting research. His methodology provided a means to accurately calculate the temperature at a milling tool tip. This has since been duplicated through a dimensional analysis approach [10]. Incorporating the eccentric geometry and travel features of Figures 2A and 2B, and generating the proper coefficients to use the data in ASM Handbook of Metals (9th Edition) available at the Marshall Space Flight Center generates the following useful expressions for the FSW tool designer:

$$T_{cutting_edge} = [16,148.58] HP_s \sqrt{\frac{V * t}{k * (pc)}} \tag{1}$$

HP_s is the specific horsepower for the alloy or workpiece, k is the coefficient of thermal conductivity for the workpiece, (pc) is the volume specific heat of the work material, V is the cutting speed at the tip of the tool (a geometric consideration) and t is the *undeformed-uncut* chip thickness, generally given by [3]:

$$t_{avg} = \frac{F_t * d}{R \cos^{-1} \left(1 - \frac{d}{R} \right) + \frac{F_t * n}{\pi * D} \sqrt{D * d - d^2}} \quad (2)$$

where R is the Radius of the cutting edge (specific to shoulder or pin in this application), d is the depth of the cut (specific to the design of tool), D is the diameter of the cutter, n is the number of teeth, and F_t is the feed per tooth. These equations reproduce the results of thermocouple measurements in the laboratory very exactly (e.g. McClure et al [5]). When applied to a very well known material (6061-T6), and overlaid onto a generic process map for a similar aluminum alloy, Figure 3 emerges.

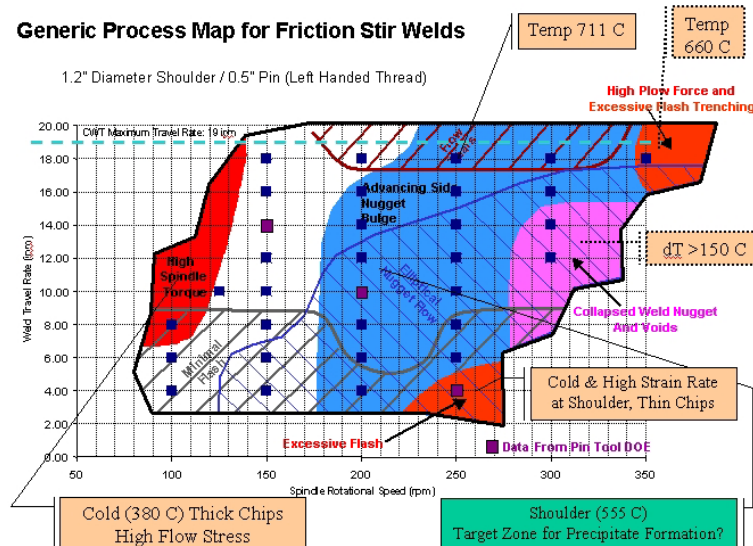

Figure 3. Generic Process Map showing empirical results and metal cutting predictions

This figure, restricted in size as it is, is highly significant. It details the empirical results of a large FSW designed experiment to determine the optimum cutting conditions in the material with callouts to show the predicted values of Equation (1). By examining the callouts and the associated problem, the underlying temperature, strain or strain rate which creates the empirically documented problem becomes apparent. More importantly, in the “sweet spot” identified by the experiment (lowest right callout), the temperature under the shoulder exceeds that required for precipitation hardening, which suggests a possible design target using these criteria and Equation (1), tailored to that specific material. Additionally, Equation (1) details the true benefit of increasing the number of scrolls in a design. The addition of a second scroll under the shoulder greatly reduces the extreme temperature effect of the shoulder, while promoting better rotation of the shear wall plug in the Nunes model of FSW [7].

Recommendations

NASA Marshall Space Flight Center should continue to investigate the use of Equation (1) and other metal cutting methodologies to assist in tool design. Metal cutting theory suggests optimization criteria and precludes the need for the complex empirical experiments, which produced the underlying process chart of Figure 3. This requires additional material data (specific horsepower of the workpiece) but this data can easily be obtained in-house with slight modifications to existing machinery. Instrumentation of horsepower at the spindle and cutting edge is critical. Additional recommendations have been provided through patent disclosures.

Acknowledgements

The author would like to thank the entire team of engineers and scientists in the Process Development Team (ED-33) of the Marshall Space Flight Center's Engineering Directorate for allowing me to work with them this summer. In particular, I appreciate the patience shown by Dr Arthur C. Nunes, Jr., during my many hours of investigation into this process, as well as Kirby Lawless, Jeff Ding, Bob Carter, Dr. Judy Schneider, Carolyn Russell, and Mandy Lazar.

References

1. Astakhov, V.P., *Metal Cutting Mechanics*. 1998, Boca Raton: CRC Press. 297.
2. Colligan, K., *Material flow behavior during friction stir welding of aluminum*. *Welding Journal*, 1999. 78 (7): p. 229S.
3. Martellotti, M.E., *An Analysis of the Milling Process*. Transactions of the American Society of Mechanical Engineers, 1941: p. 677.
4. Martellotti, M.E., *An Analysis of the Milling Process, Part II-Down Milling*. Transactions of the American Society of Mechanical Engineers, 1945: p. 233.
5. McClure, J.C., et al. *A Thermal Model of Friction Stir Welding*. in *5th International Conference on Trends in Welding Research*. 2001.
6. Murr, L.E., et al., *Microstructures in friction-stir welded metals*. *Journal of Materials Processing & Manufacturing Science*, 1999. 7(2): p. 145.
7. Nunes, A.C. *Wiping Metal Transfer in Friction Stir Welding*. in *Proceedings of the 2001 TMS Annual Automotive Alloys and Joining Aluminum Symposia*. 2001. New Orleans, LA: The Minerals, Metals and Materials Society.
8. Reynolds, A.P., W.D. Lockwood, and T.U. Seidel, *Processing-property correlation in friction stir welds*, in *Aluminum Alloys: Their Physical and Mechanical Properties, Pts 1-3*. 2000. p. 1719.
9. Reynolds, A.P. and W. Tang. *Alloy, Tool Geometry, and Process Parameter Effects of Friction Stir Welding Energies and Resultant FSW Joint Properties*. in *Friction Stir Welding and Processing*. 2001. Indianapolis, Indiana: TMS.
10. Shaw, M.C., *Metal Cutting Principles*. 1984, Oxford: Clarendon Press.
11. Silin, S.S., *Similarity Methods in Metal Cutting (in Russian)*. 1979, Moscow: Mashinostroenie.
12. Thomas, W.M., Dolby, R.E. *Friction Stir Welding Developments*, in *6th International Conference on Trends in Welding Research*. 2002. Pin Mountain, Georgia.