

## OVERVIEW OF NASA GLENN SEAL PROGRAM

Bruce M. Steinetz, Margaret P. Proctor, and Patrick H. Dunlap, Jr.  
National Aeronautics and Space Administration  
Glenn Research Center  
Cleveland, Ohio

Irebert Delgado  
U.S. Army Research Laboratory  
Glenn Research Center  
Cleveland, Ohio

Jeffrey J. DeMange, Christopher C. Daniels, and Scott B. Lattime  
Ohio Aerospace Institute  
Brook Park, Ohio

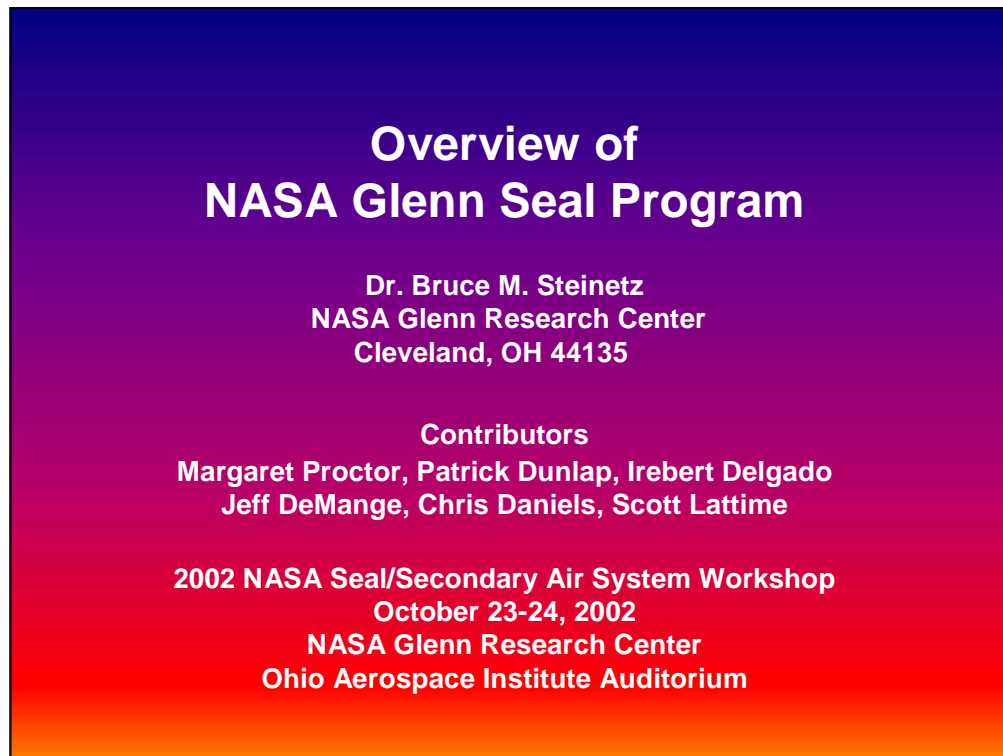

NASA Glenn hosted the Seals/Secondary Air System Workshop on October 23-24, 2002. At this workshop NASA and our industry and university partners share their respective seal technology developments. We use these workshops as a technical forum to exchange recent advancements and “lessons-learned” in advancing seal technology and solving problems of common interest. As in the past we are publishing two volumes. Volume I will be publicly available and individual papers will be made available on-line through the web page address listed at the end of this chapter. Volume II will be restricted under International Traffic and Arms Regulations (I.T.A.R.) and Export Administration Regulations (E.A.R.).

## Workshop Agenda

Wednesday, Oct. 23, Morning

<b>Registration</b>	<b>8:00 a.m.–8:30 a.m.</b>
<b>Introductions</b> Introduction Welcome to NASA Glenn NASA Technology Requirements Overview of NASA Glenn Seal Program	<b>8:30 a.m.–9:30 a.m.</b> Dr. Bruce Steinetz, R. Hendricks/NASA GRC Mr. Donald Campbell, Director, NASA GRC Dr. Woodrow Whitlow, Director of R&T at NASA GRC Dr. Bruce Steinetz/NASA GRC
<b>Program Overviews and Requirements</b> Air Force Turbine Engine Development + Seal Needs Overview of NASA's UEET and TBCC/RTA Programs Overview of NASA's Access to Space Programs Revolutionary Turbine Accelerator (RTA) Engine Dev.	<b>9:30 a.m.–11:00 a.m.</b> Dr. Lewis Rosado, WPAFB Dr. Joe Shaw, C. Peddie/NASA GRC Mr. Harry Cikanek/NASA GRC Dr. Ken Suder, Paul Bartolotta, N. McNelis/NASA GRC
<b>Break</b>	<b>11:00-11:15</b>
<b>Turbine Seal Development Session I</b> Overview of Aspirating Seal Final Preparations for GE90 Test Foil Face Seal Proof-of-Concept Demo. Testing Overview of Turbine Seal Testing at GRC	<b>11:15-12:15</b> Ms. Marcia Boyle, B. Albers; GE Aircraft Engines Mr. John Munson, Rolls Royce Allison <i>Withdrawn</i> Mr. Darrell Grant, Navy; Dr. Giri Agrawal, R&D Dynamics Ms. M.P. Proctor, NASA GRC; I.R. Delgado, US Army Research Lab
<b>Lunch OAI Sun Room</b>	<b>12:30-1:30</b>

 NASA Glenn Research Center  
Seal Team

The first day of presentations included overviews of NASA programs devoted to advancing the state-of-the-art in aircraft and turbine engine technology. Director Campbell provided an overview of NASA's Mission and Goals. Dr. Whitlow presented an overview of NASA's Technology Requirements. Ms. Peddie presented an overview of the Ultra-Efficient-Engine Technology (UEET) program that is aimed at developing highly-loaded, ultra-efficient engines that also have low emissions (NO<sub>x</sub>, unburned hydrocarbons, etc.). Mr. Cikanek of NASA's Space Project office summarized NASA's Access to Space Programs citing areas where advanced seals are required.

Dr. Suder provided an overview of the turbine-based-combined-cycle (TBCC)/Revolutionary Turbine Accelerator (RTA) program. The goal of this program is to develop turbine engine technology that would enable a turbine-engine based first stage launch system for future highly re-usable launch vehicles.

Dr. Steinetz presented an overview of the NASA seal development program. Representatives from GE provided insight into their advanced seal development program. Ms. Proctor of NASA Glenn presented an overview of turbine testing at NASA GRC.

## Workshop Agenda

Wednesday, Oct. 23, Afternoon

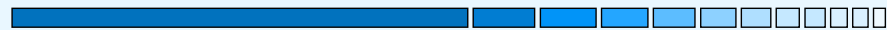

### Turbine Seal Development Session II

High-Speed, High-Temp. Turbine Disk Life Study  
for Temp. High Speed Seal Rig

Turbine Engine Clearance Control Systems:  
Current Practices and Future Directions

Development of Advanced Seals for Industrial  
Turbine Applications

Overview of Seal Development at Technetics

**1:30-3:00**

Mr. Irebert Delgado U.S. Army Research Laboratory High

Dr. S. Lattime, OAI, B. Steinetz, NASA GRC

Dr. Ray Chupp/General Electric-CRD

Mr. Doug Chappel, Technetics Corp. *Withdrawn*

### Break

**3:00-3:20**

### Turbine Seal Development Session III

Some Considerations Regarding the Design of  
Finger Seals

Evaluation of Large Compliant Gas Foil Seals Under  
Engine Simulated Conditions

Film Riding Brush Seal: Preliminary Analysis

**3:20-4:20**

Dr. Jack Braun/U. Akron; V.V. Kudriavtsev, CFD Canada  
H.M. Pierson, Univ. of Akron

Drs. Jim Walton, M. Salehi, H. Heshmat, Mohawk  
Innovative Technology

Dr. Wilbur Shapiro, Tribos Engineering, P.C.

### Adjourn

**6:15-?**

**Group Dinner Don's Lighthouse Grille**



NASA Glenn Research Center  
Seal Team

Mr. Delgado presented results of fatigue life and crack growth tests performed on material taken from a test rotor of the high speed seal test rig. Dr. Lattime gave an overview of current practices and future directions in turbine tip clearance control systems. Dr. Chupp of GE-Global Research Center (formerly GE-Corporate Research Center) presented industrial turbine seal developments.

Dr. Braun presented preliminary investigations into metallic non-contacting finger seals. Dr. Walton of Mohawk Innovative Technology presented their company's progress in developing and assessing a new compliant foil seal. Dr. Shapiro presented a preliminary analysis performed on a film-riding brush seal concept.

## Workshop Agenda

Thursday, Oct. 24, Morning

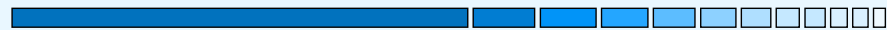

### Registration at OAI

8:00-8:30

### Space Vehicle Development

8:30-9:45

Overview of Air Force Space Operations Vehicle Development Plans

Dr. Jeff Zweber, Space Operations Vehicle, WPAFB

Overview of Boeing Advanced Space Vehicles and Seal Needs

Dr. Todd Steyer, Boeing Space and Comm.

Overview of ISTAR Engine Dev. and Seal Needs

Mr. Ravi Nigam, R. Kreidler, P&W

### Break

9:45 -10:00

### Structural Seal Development

10:00-12:15

3<sup>rd</sup> Generation RLV Structural Seal Dev. Program Develop. and Capabilities of Unique Structural Seal Test Rigs

Mr. Pat Dunlap, B. Steinetz/NASA GRC

CFD Analyses of ISTAR Engine Seals

Mr. Jeff DeMange/OAI; P. Dunlap, B. Steinetz/NASA GRC

Atlas V SRM Gap Analysis with Carbon Fiber Rope

Mr. Alton Reich, M. Athavale/CFD-RC, R. Kreidler P&W

P. Dunlap, B. Steinetz/NASA GRC

Dr. Gary Luke, Aerojet, Mr. Bob Prozan, CEA

Overview of Seal Development at Albany-Techniweave

Mr. Bruce Bond/Albany Techniweave

### Lunch OAI Sun Room

12:15-1:15



NASA Glenn Research Center  
Seal Team

Dr. Zweber presented an Overview of the Air Force's Space Operations Vehicle. Dr. Steyer of Boeing Space and Communications presented Boeing's plans for future space vehicles and seal lesson's learned from the Shuttle Orbiter.

NASA is investigating hybrid rocket/air-breathing systems to increase propulsion system specific impulse. Mr. Nigam presented an overview of the ISTAR (Integrated System Test of an Air-breathing Rocket) program and engine seal challenges. Mr. Reich presented plans for CFD/thermal analyses of the ISTAR engine ramp seals. Mr. Dunlap and Mr. DeMange presented overviews of NASA Glenn's 3rd generation RLV structural seal development program and unique test rigs under development, respectively.

Dr. Luke and Mr. Prozan presented results of a program investigating the feasibility of using the GRC-developed thermal barrier in the nozzle joint of the solid rocket motors for the Atlas 5 Rocket. Mr. Bond presented an overview of the seal developments at Albany-Techniweave.

## Workshop Agenda

Thursday, Oct. 24, Afternoon



### High Temperature Materials and Related Developments

1:15-2:45

High Temperature Metallic Seal Development

Mr. Greg More, Advanced Products  
Dr. Amit Datta/Advanced Components & Materials

Overview of RCI's Materials Dev. for Space Applications

Mr. Ted Paquette, Refractory Composites, B. Sullivan MR&D

Silicon Carbide: Material Properties and Applications  
Overview of CMC Development: Promise, Problems, Progress, Prognosis

Mr. Dean P. Owens, St. Gobain  
Dr. James DiCarlo, NASA GRC

### Tour of NASA Seal Test Facilities

2:45-4:15

### Adjourn



NASA Glenn Research Center  
Seal Team

Advanced structural seals require application of advanced high temperature materials. The closing session of the conference presented seal concepts and materials being developed at several locations. Mr. More (Advanced Products) and Dr. Datta (Advanced Components and Materials) presented an overview of the high temperature metallic seal development. Mr. Paquette presented an Overview of Refractory Composites Co. materials development for space applications including development of an advanced composite (hot-structure) control surface for a future re-usable launch vehicle.

Mr. Owens described silicon carbide developments at St. Gobain, Niagra Falls, NY. Dr. DiCarlo of NASA GRC provided an overview of ceramic matrix composites development: promise, problems, progress and prognosis.

## NASA Glenn Seal Team Organization



**Seal Team Leader: Bruce Steinetz**

Mechanical Components Branch/5950

### **Turbine Engine Seal Development**

Principal Investigator: **Margaret Proctor**

Researcher: **Irebert Delgado**

Consultant: **Dave Fleming** Operations: **Joe Flowers**

**Develop non-contacting, low-leakage turbine seals**

### **Structural Seal Development**

Principal Investigator: **Pat Dunlap**

Sr. Researcher: **Jeff DeMange**

Design Eng: **Dan Breen**

**Develop resilient, long-life, high-temp. structural seals**

### **Acoustic Seal Development**

Principal Investigators: **Chris Daniels/B. Steinetz**

**Develop non-contacting, virtually no-leakage acoustic-based seals**

### **Adaptive Seal Development**

Principal Investigators: **Scott Lattime/B. Steinetz**

**Develop novel adaptive blade-tip/inter-stage seals**



NASA Glenn Research Center  
Seal Team

The Seal Team is divided into four primary areas. These areas include turbine engine seal development, structural seal development, acoustic seal development, and adaptive seal development. The turbine seal area focuses on high temperature, high speed shaft seals for secondary air system flow management. The structural seal area focuses on high temperature, resilient structural seals required to accommodate large structural distortions for both space- and aero-applications.

Our goal in the acoustic seal project is to develop non-contacting, low leakage seals exploiting the principles of advanced acoustics. We are currently investigating a new acoustic field known as Resonant Macrosonic Synthesis (RMS) to see if we can harness the large acoustic standing pressure waves to form an effective air-barrier/seal.

Our goal in the adaptive seal project is to develop advanced sealing approaches for minimizing blade-tip (shroud) or interstage seal leakage. We are planning on applying either rub-avoidance or regeneration clearance control concepts (including smart structures and materials) to promote higher turbine engine efficiency and longer service lives.

## Why Seals?

### AST Study Results: Expected Seal Technology Payoffs

Seal Technology	Study Engine/ Company	System Level Benefits
Large diameter aspirating seals (Multiple locations)	GE90-Transport/ GE	-1.86% SFC -0.69% DOC+I
Active Clearance Control (HPT)	Large Commercial GE/NASA	-1 to 2% SFC
Film riding seals (Turbine inter-stage seals)	Regional-AE3007/ Allison	> -0.9% SFC > -0.89% DOC+I
Advanced finger seals	AST Regional/ Honeywell	-1.4% SFC -0.7% DOC+I

### UEET Program Goal Reduce Fuel Burn by 8-15%

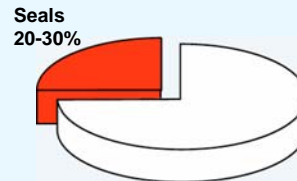

- Seals provide high return on technology \$ investment  
Same performance goals possible through modest investment in the technology development  
Example: 1/5th to 1/4th cost of obtaining same performance improvements of re-designing/re-qualifying the compressor
- Seal contribution to program goals: 2 to 3% SFC reduction

### Advanced Seal Technology: An Important Player



NASA Glenn Research Center  
Seal Team

Cycle studies have shown the benefits of increasing engine pressure ratios and cycle temperatures to decrease engine weight and improve performance in next generation turbine engines. Advanced seals have been identified as critical in meeting engine goals for specific fuel consumption, thrust-to-weight, emissions, durability and operating costs. NASA and the industry are identifying and developing engine and sealing technologies that will result in dramatic improvements and address each of these goals for engines entering service in the 2005-2007 time frame.

General Electric, Allison and AlliedSignal Engines all performed detailed engine system studies to assess the potential benefits of implementing advanced seals. The study results were compelling. Implementing advanced seals into modern turbine engines will net large reductions in both specific fuel consumption (SFC) and direct operating costs including interest (DOC+I) as shown in the chart (Steinetz et al, 1998).

Applying the seals to just 2 or 3 engine locations would reduce SFC 2-3% . This represents a significant (20-30% ) contribution toward meeting the overall goals of NASA's Ultra-Efficient Engine Technology (UEET) program.

## Aspirating Seal Development: GE90 Demo Program Funded UEET Seal Development Program

### Goal:

Complete aspirating seal development by conducting full scale (36 in. diameter) aspirating seal demonstration tests in GE90 engine.

### Payoffs:

- Leakage <1/5th labyrinth seal
- Operates without contact under severe conditions:
  - + 10 mil TIR
  - + 0.25°/0.8 sec tilt maneuver loads (0.08° deflection!)
- Decrease SFC by 1.86% for three locations

### Schedule:

- Hardware fabrication by 3Q FY01 (Complete)
- Static closure test 4Q FY01 (Complete)
- GE90 engine test: FY03
- Data analysis and report: FY03

### Partners:

GE/Stein Seal/CFDRC/NASA GRC



NASA Glenn Research Center  
Seal Team

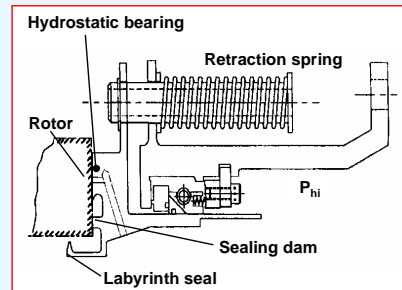

General Electric GE90



General Electric is developing a low leakage aspirating face seal for a number of locations within modern turbine applications. This seal shows promise both for compressor discharge and balance piston locations.

The seal consists of an axially translating mechanical face that seals the face of a high speed rotor. The face rides on a hydrostatic cushion of air supplied through ports on the seal face connected to the high pressure side of the seal. The small clearance (0.001-0.002 in.) between the seal and rotor results in low leakage (1/5th that of new labyrinth seals). Applying the seal to 3 balance piston locations in a GE90 engine can lead to >1.8% SFC reduction. GE Corporate Research and Development tested the seal under a number of conditions to demonstrate the seal's rotor tracking ability. The seal was able to follow a 0.010 in. rotor face total indicator run-out (TIR) and could dynamically follow a 0.25° tilt maneuver (simulating a hard maneuver load) all without face seal contact. More details can be found in Boyle and Albers, 2003 in this Seal Workshop Proceedings and Turnquist, et al 1999. The NASA GRC Ultra Efficient Engine Technology (UEET) Program is funding GE to demonstrate this seal in a ground-based GE-90 demonstrator engine in 2003.



## NASA GRC Tests Honeywell Finger Seal

### Objective:

Evaluate leakage and power loss performance of finger seal for Honeywell advanced-demonstrator engine

### Approach:

- Test seal using new NASA GRC seal test rig
- Measure seal tare torque and power loss using new torque meter.
- Measure pad wear: visual; weight-change

### Results:

- Seal leakage performance was acceptable
- Power loss comparable to brush seal. Desire to further reduce power loss.
- Examining re-design options with possible second series of tests.

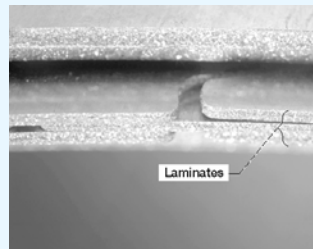
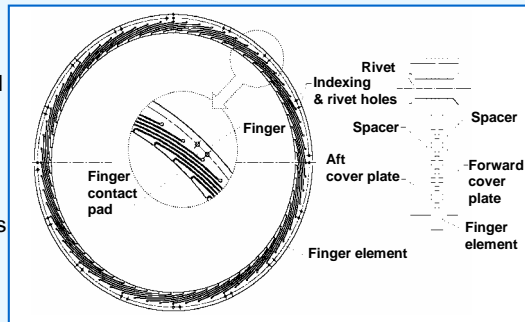

Close-up view: Typical finger laminates



NASA Glenn Research Center  
Seal Team

NASA GRC recently completed a series of tests to evaluate the performance of a finger seal being considered by Honeywell for an advanced demonstrator-engine.

Finger seals are constructed of a series of laminates deriving radial flexibility through slots between adjacent fingers. Several laminates are stacked on top of each other and indexed so as to block the flow through successive laminates. Finger seals exhibit low leakage comparable to brush seals but can be produced at a fraction of the cost of brush seals.

The NASA GRC tests showed the seal exhibited acceptable leakage. The measured seal power loss was acceptable for certain applications but was high for other applications. For further details, please see Proctor et al, 2002 and Proctor et al, 2003 in this Seal Workshop Proceedings.

## Non-Contacting Finger Seal Development NASA GRC/University of Akron

### Objective:

Develop non-contacting finger seal to overcome finger element wear and heat generation for future turbine engine systems

### Approach:

- Solid modeling for stick and pad motion/stresses
- 3-D Fluid/solid interaction for leakage evaluation
- Design guidelines
- Experimental verification

### Status:

Solid modeling → 90% completed

3-D Fluid/solid interaction → underway

Design guidelines → underway

Experimental verification:

Test section design → Complete

Test Section construction → 60% complete

### Program:

Cooperative Agreement: Dr. Braun (U. of Akron)

M. Proctor, Grant Monitor



NASA Glenn Research Center  
Seal Team

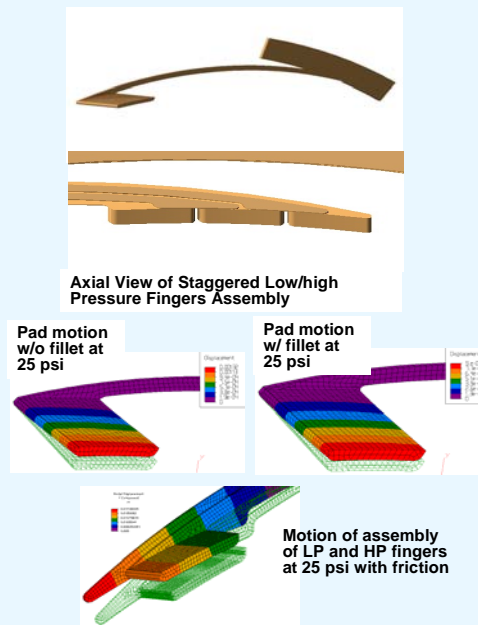

Conventional finger seals like brush seals attain low leakage by operating in running contact with the rotor. The drawbacks of contacting seals include wear over time, heat generation, and power loss.

NASA Glenn has developed several concepts for a non-contacting finger seal. In one of these concepts the rear (low-pressure, downstream) fingers have a lift pad (see uppermost figure) and the upstream (high pressure side) fingers are designed to block the flow through the slots of the downstream fingers (see middle figure). The pressure-balance on the downstream-finger lift-pads cause them to lift. The front fingers are designed to ride slightly above the rotor preventing wear. Pressure acts to hold the upstream fingers against the downstream fingers. It is anticipated that the upstream/downstream fingers will move radially as a system in response to shaft transients. Though a small pin-hole leakage path exists between the inner diameter of the upstream fingers, the rotor, and the downstream fingers, this small pin-hole doesn't cause a large flow penalty especially considering the non-contacting benefits of the overall approach.

Through a grant with University of Akron, NASA Glenn is working with Dr. J. Braun of University of Akron to perform analyses and tests of this GRC concept. Preliminary finite element analysis results of the finger movements subjected to various pressures are shown. More details can be found in Braun et al, 2003 in this Seal Workshop Proceedings.

## Turbine Blade Tip Seal Development

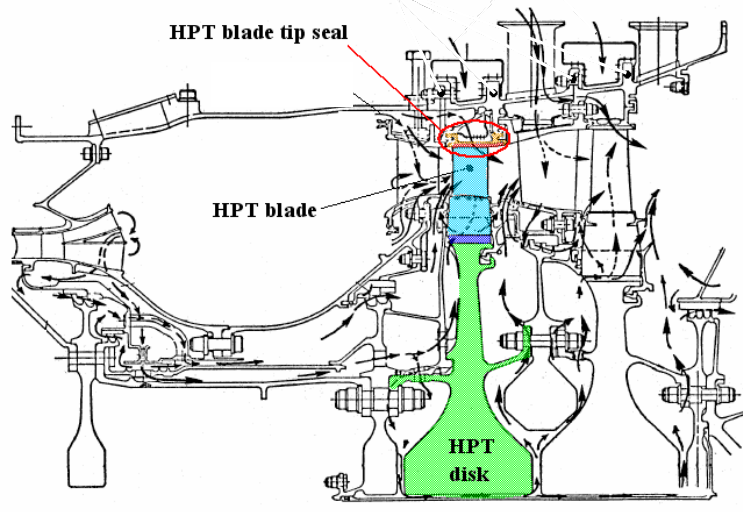

NASA Glenn Research Center  
Seal Team

Current commercial jet engines control the high pressure turbine (HPT) blade tip clearances using active thermal control. Based on a model based schedule involving a variety of engine operating parameters (e.g. RPM, temperatures, pressures, etc) air is directed to cool the HPT case structure and keep cruise clearances at their minimum practical level. Though effective for current engines, future engines require tighter, faster control to improve turbine stage efficiency, to delay or slow the growth of exhaust gas temperature (EGT), and increase engine time-on-wing.

## Benefits of HPT Tip Clearance Control

### Specific Fuel Consumption/Fuel Burn

- 0.010-in. tip clearance is worth ~1% SFC
- Less fuel burn, reduces emissions
  - (Ref.: Lattime & Steinetz, 2002)

### Service Life

- Deterioration of exhaust gas temperature (EGT) margin is the primary reason for aircraft engine removal from service.
- 0.010-in. tip clearance is worth ~10 °C EGT.
- Allows turbine to run at lower temperatures, increasing cycle life of hot section and engine time on wing
- Maintenance costs for overhauls can easily exceed \$1M.

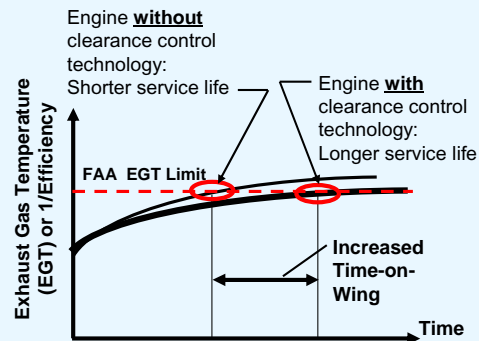

**Active Clearance Control Technology Promotes High Efficiency and Long Life**



NASA Glenn Research Center  
Seal Team

Blade tip clearance opening is a primary reason for turbine engines reaching their FAA certified exhaust gas temperature (EGT) limit and subsequent required refurbishment. NASA GRC has embarked on a program to overcome or greatly mitigate this clearance opening problem.

Benefits of clearance control in the turbine section include retained EGT margins, higher efficiencies, longer range, and lower emissions (because of lower fuel-burn). Benefits of clearance control in the compressor include better compressor stability (e.g. resisting stall/surge), higher stage efficiency, and higher stage loading. All of these features are key for future NASA and military engine programs.

## Adaptive Seal Technology Development: Approach

Develop adaptive seals that maintain small running clearances by

- Rub avoidance, or
- Regeneration

### Fast rub-avoidance ACC system

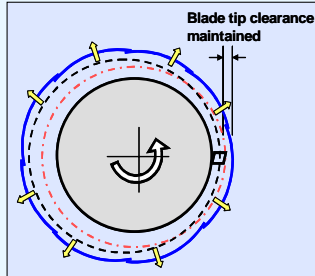

### Regenerative seal material systems

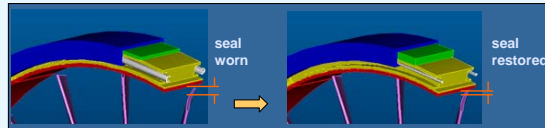

NASA Glenn Research Center  
Seal Team

NASA Glenn is pursuing two approaches. The first is rub-avoidance in which an active clearance control system would actively move the seal segments out of the way during the transient event to avoid blade rubs. The second is regeneration in which damage is healed after a rub event returning clearances back to their design levels at certain prescribed cycle intervals using specially engineered materials. More details regarding this program can be found in Lattime and Steinetz 2003 in this Seal Workshop Proceedings, and Lattime and Steinetz, 2002.

## NASA GRC Structural Seal Development Goals: 3rd Generation Reusable Launch Vehicle Program

- Develop hot (2500+°F), flexible, dynamic structural seals for ram/scramjet propulsion systems (TBCC, RBCC)

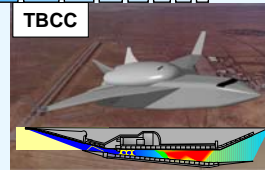
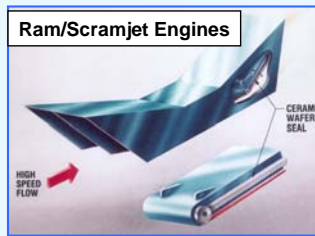

- Develop reusable re-entry vehicle control surface seals to prevent ingestion of hot (6000 °F) boundary layer flow

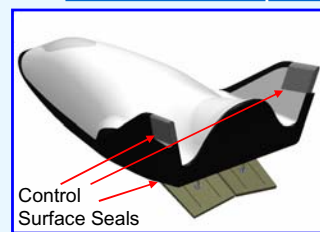

**Hot, dynamic seals critical to meeting 3rd generation program life, safety, and cost goals**

Example: X-37; X-38 CRV



NASA Glenn Research Center  
Seal Team

NASA is currently funding research on advanced technologies that could greatly increase the reusability, safety, and performance of future Reusable Launch Vehicles (RLV). Research work is being performed under NASA's 3rd Generation RLV program on both high specific impulse ram/scramjet engines and advanced re-entry vehicles.

NASA GRC is developing advanced structural seals for both propulsion and vehicle needs by applying advanced design concepts made from emerging high temperature ceramic materials and testing them in advanced test rigs that are under development. See Dunlap, et al, 2003 in this Seal Workshop Proceedings for further details.

## Example Structural Seals Being Investigated

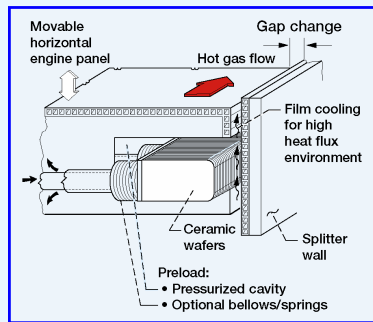

### Ceramic Wafer Seal

- High temperature operation: up to 2500°F
- Low Leakage
- Flexibility: Relative sliding of adjacent wafers conforms to wall distortions
- Ceramic material lighter weight than metal system
- Tandem seals permit central cavity purge (cooling)

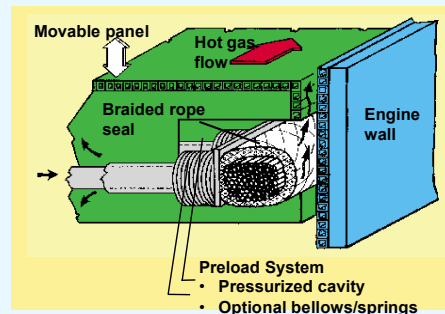

### Braided Rope Seal

- High temperature operation: 1500-2200+ °F (500-1200 °F hotter than graphite seals)
- Flexible: seals & conforms to complex geometries
- Hybrid design (ceramic core/superalloy wire sheath) resists abrasion
- Tandem seals permit central cavity purge (cooling)



NASA Glenn Research Center  
Seal Team

NASA GRC's work on high temperature structural seal development began in the late 1980's during the National Aero-Space Plane (NASP) project. GRC led the in-house propulsion system seal development program and oversaw industry efforts for propulsion system and airframe seal development for this vehicle.

Two promising concepts identified during that program included the ceramic wafer seal (Steinetz, 1991) and the braided rope seal (Steinetz and Adams, 1998) shown here. By design, both of these seals are flexible, lightweight, and can operate to very high temperatures (2200+°F). These seal concepts are starting points for the extensive seal concept development and testing planned under NASA's 3rd Generation high temperature seal development tasks.

## Hot Compression/Scrub Seal Test Rig: Overview

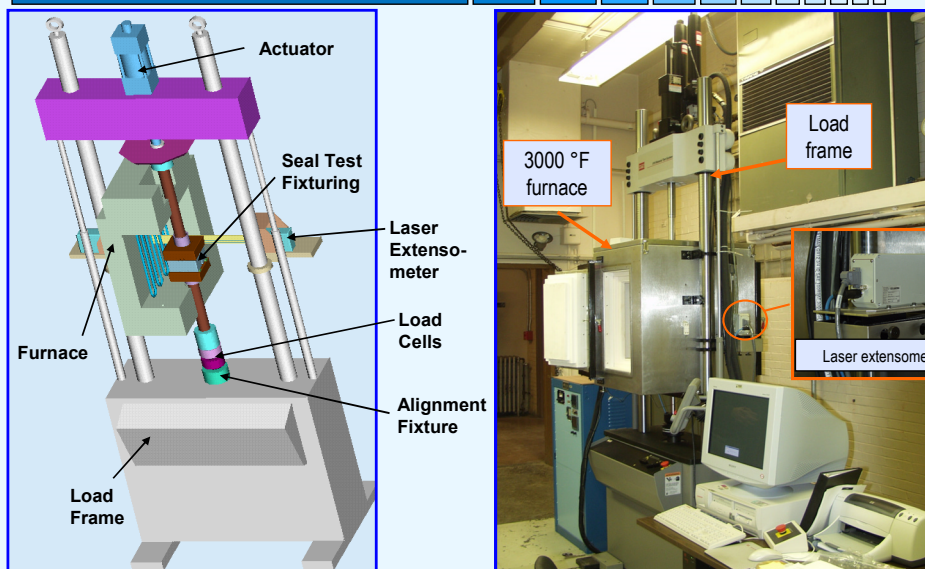

 NASA Glenn Research Center  
Seal Team

One of the rigs that NASA Glenn Research Center is assembling for the structural seals area consists of three main components: an MTS servohydraulic load frame, an ATS high temperature air furnace, and a Beta LaserMike non-contact laser extensometer. The rig will permit independent (i.e. non-simultaneous) testing of both seal resiliency characteristics (compression test) and seal wear performance (scrub test) at temperatures up to 3000 °F (1650 °C). This one-of-a-kind equipment will have many unique capabilities for testing of numerous seal configurations, including dual load cells (with multi-ranging capabilities) for accurate measurement of load application, dual servovalves to permit precise testing at multiple stroke rates, a large capacity high temperature air furnace, and a non-contact laser extensometer system to accurately measure displacements.

As shown in the photograph on the right, the load frame, furnace, laser extensometer, data system and considerable test fixture hardware has been delivered. We are currently assembling elements together and performing initial check-out tests.



## Hot Compression/Scrub Seal Fixture Illustrations

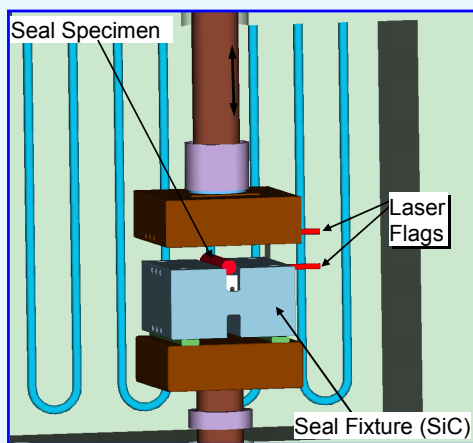

### **Compression Test Rig**

Measure seal load vs. linear compression, preload, & stiffness at temperature.

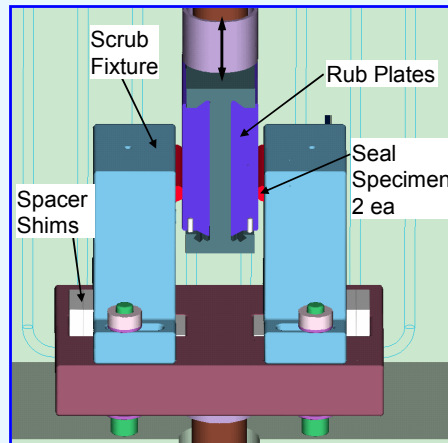

### **Scrub Test Rig**

Measure seal wear rates and frictional loads for various test conditions at temperature



NASA Glenn Research Center  
Seal Team

One of the primary tests to be conducted with the new rig will be high temperature compression tests to assess seal resiliency. These evaluations will be carried out by employing a number of user-defined parameters including temperature, loading rate, amount of compression, and mode of application (single load application vs. cycling). The setup will consist of upper and lower silicon carbide (SiC) platens which compress a seal specimen residing in the groove of a seal holder. Small pins (laser flags) will be inserted into both the upper platen and seal fixture and will be used in concert with the laser extensometer system previously mentioned to measure compression level as a function of time. See DeMange, et al, 2003 in this Seal Workshop Proceedings for further details.

A second setup using the same MTS rig will be used to assess high temperature wear characteristics of structural seal candidates. In this setup, a SiC seal holder containing a seal specimen will flank each side of a scrubbing saber (rub plate) assembly. The seal holders will be held in place through a novel high temperature anchoring system. A load cell mounted at the bottom of the lower platen will permit monitoring of the friction loads. Numerous combinations of testing parameters will be possible with this test setup, including various temperature ranges, seal compression levels, scrubbing rates and profiles, etc. This design will also facilitate post-scrubbing flow tests.

## Thiokol Selects NASA GRC Thermal Barrier for RSRM Joint Redesign



- Shuttle RSRM's experiences periodic hot gas effects in certain nozzle-joints leading to extensive reviews before flight.
- Glenn thermal barrier braided of carbon fiber has shown outstanding ability to prevent hot (5500°F) gas from effecting downstream O-rings in multiple sub- and full-scale RSRM tests.

### Redesigned RSRM Nozzle-to-Case Joint w/GRC thermal barrier

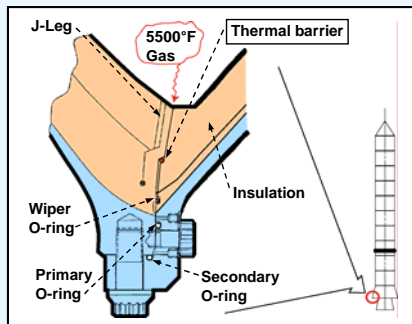

### GRC 5500°F Flame Test

Ref: Steinetz, & Dunlap 1999 NASA TM-1999-209278



**Thiokol has selected GRC thermal barrier for Nozzle-to-Case Joint redesign and qualifying performance for Joint Numbers 1, 2, & 5.**



NASA Glenn Research Center  
Seal Team

Periodically several of the Shuttle's solid rocket motor nozzle joints experience hot gas effects. Over the past several years, engineers from NASA Glenn, Marshall Space Flight Center, Thiokol, and Albany-Techniweave have been investigating the feasibility of applying the NASA GRC developed carbon fiber rope to overcome this issue. More details of this program can be found in Steinetz and Dunlap, 2001, Steinetz and Dunlap, 2002, and U.S. Patent # 6,446,979 B1.

The braided carbon fiber thermal barrier is the primary candidate being considered for the redesign of nozzle-to-case joint and for nozzle joints 1-5. Incorporation of the thermal barrier into the nozzle joints of the Space Shuttle RSRMs eliminates hot gas penetration to nozzle joint Viton O-rings. Numerous lab, sub-scale rocket and full-scale rocket tests have demonstrated the feasibility of the carbon fiber thermal barrier, as will be discussed on the next chart.

## NASA Glenn Carbon Fiber Rope Thermal Barrier Full Scale Shuttle Solid Rocket Motor Static Tests

### Objective

Investigate feasibility of new joint designs with carbon fiber rope (CFR) thermal barrier to protect Viton O-ring seals in full-scale solid rocket motors

### Full scale motor tests

#### FSM-9 test

Nozzle-to-case joint 1 CFR  
Joint #2 2 CFRs

#### ETM-2 test

Joint 1\* 2 CFR  
Joint 2\*\* 2 CFR  
Joint 5\* 1 CFR

\* Replace RTV with CFR

\*\* Demonstrate fault tolerance of CFR

### Thiokol Full-Scale Solid Rocket Motor Static Test



File Image

### Full scale motor tests completed:

FSM-9 May 24, 2001 Successfully demonstrated CFR in nominal joint  
ETM-2 November 1, 2001 Examined flawed & nominal joint with CFR



NASA Glenn Research Center  
Seal Team

On May 24, 2001, the NASA Glenn developed braided carbon fiber thermal barrier was successfully evaluated by Thiokol in a full-scale static motor test, designated FSM-9. In this test carbon fiber ropes (CFRs) were tested in both the nozzle-to-case joint and Joint 2. During the solid rocket motor firing, temperatures and pressures were measured both upstream and downstream of the joints. In Joint 2 for instance, measurements indicated that temperature upstream of the CFR were 3700 °F, the temperature between the two CFRs was 500 °F, and downstream the temperature was only 175 °F - well within the Viton O-ring short-term temperature limit of 800 °F. This test successfully demonstrated the design intent of the CFR for both joints tested, clearing the way for future more aggressive full-scale static motor tests in November, 2001.

On November 1, 2001, the CFR was tested in joints 1, 2, and 5 in a full-scale solid-rocket motor test designated ETM-2. In joints 1 and 5 CFRs was used in place of the RTV joint compound. RTV often cures with voids that can lead to rocket gas impingement on the Viton O-rings. Replacing the RTV with the CFR eliminates the focusing of the hot rocket gas, reduces the temperature of the gas impinging on the Viton O-rings, and significantly reduces assembly time.

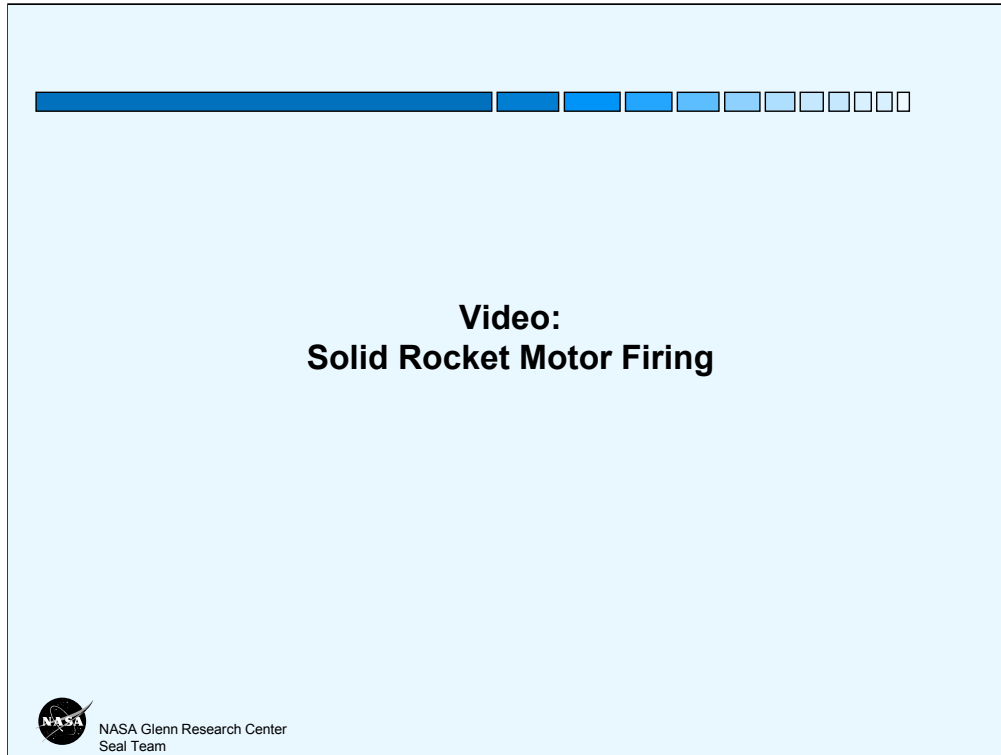

During the workshop presentation, a video was shown of the full scale static motor test-firing that included the thermal barrier.

## Elegant Solution: Carbon Fiber Rope Thermal Barrier

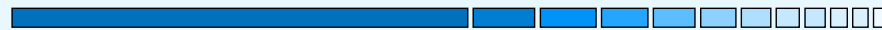

Heat effect of joint fill compound  
Typical sooting of metal flange

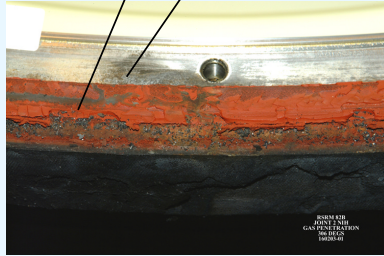

**Current Design**

Soot and heat is stopped at the thermal barrier



**New Design**

- Blocks heat and combustion products from entering nozzle joints
- Enables solid rocket motor joint assembly in significantly less time (approximately 1/6th time) as compared to the current joint fill compound approach
- Simplifies joint-assembly and reproducibility

**Schedule:**

- **Qualifying full scale motor test:** Early 2003
- **Commence assembling in RSRM:** 2003



NASA Glenn Research Center  
Seal Team

This slide shows the benefits of incorporating the thermal barrier.

Shown here for comparison purposes, is the condition of Joint 2 before and after implementation of the thermal barrier design. The left image shows the poor condition of the joint after flight before the thermal barriers were added. The right image shows the excellent condition of the joint after the full-scale test with the thermal barriers showing no heat effect of any elements in the joint.

Schedule: After a final qualifying full scale motor test scheduled in early 2003, it is anticipated that the boosters will be assembled with the thermal barriers later that year. It is anticipated that the CFR will be flown on the Space Shuttle in 2005.

## Summary

- **Seals technology recognized as critical in meeting next generation aero- and space propulsion and space vehicle system goals**
  - Performance
  - Efficiency
  - Life/Reusability
  - Safety
  - Cost
- **NASA Glenn is developing seal technology and/or providing technical consultation for the Nation's key aero- and space advanced technology development programs.**



NASA Glenn Research Center  
Seal Team

NASA Glenn is currently performing seal research supporting both advanced turbine engine development and advanced space vehicle/propulsion system development. Studies have shown that decreasing parasitic leakage through applying advanced seals will increase turbine engine performance and decrease operating costs.

Studies have also shown that higher temperature, long life seals are critical in meeting next generation space vehicle and propulsion system goals in the areas of performance, reusability, safety, and cost goals.

NASA Glenn is developing seal technology and providing technical consultation for the Agency's key aero- and space technology development programs.

## NASA Seals Web Sites

- **Turbine Seal Development**

- + <http://www.grc.nasa.gov/WWW/TurbineSeal/TurbineSeal.html>

- NASA Technical Papers

- Workshop Proceedings

- **Structural Seal Development**

- + <http://www.grc.nasa.gov/WWW/structuralseal/>

- + [http://www/lerc.nasa.gov/WWW/TU/InventYr/1996Inv\\_Yr.htm](http://www/lerc.nasa.gov/WWW/TU/InventYr/1996Inv_Yr.htm)

- NASA Technical Papers

- Discussion



NASA Glenn Research Center  
Seal Team

The Seal Team maintains three web pages to disseminate publicly available information in the areas of turbine engine and structural seal development. Please visit these web sites to obtain past workshop proceedings and copies of NASA technical papers and patents.

## References

- Lattime, S.B., Steinetz, B.M. 2002 "Turbine Engine Clearance Control Systems: Current Practices and Future Directions," NASA TM-2002-211794, AIAA 2002-3790.
- Proctor, M.P.; Kumar, A.; Delgado, I.R.; 2002, "High-Speed, High Temperature, Finger Seal Test Results," NASA TM-2002-211589, AIAA-2002-3793.
- Steinetz, Bruce M., Dunlap, Patrick H., 2002, "Rocket Motor Joint Construction Including Thermal Barrier," U.S. Patent No. 6,446,979 B1, Issue Date: September 10.
- Steinetz, Bruce M.; Dunlap, Patrick H.: 2001, "Development of Thermal Barriers for Solid Rocket Motor Nozzle Joints" Journal of Propulsion and Power, Vol. 17 No. 5, pp. 1023-1034, September/October, also NASA-TM-1999-209191, June 1999.
- Steinetz, B.M., Hendricks, R.C., and Munson, J.H., 1998 "Advanced Seal Technology Role in Meeting Next Generation Turbine Engine Goals," NASA TM-1998-206961.
- Steinetz, Bruce M.; Adams, Michael L.: 1998, "Effects of Compression, Staging and Braid Angle on Braided Rope Seal Performance", J. of Propulsion and Power, Vol. 14, No. 6, also AIAA-97-2872, 1997 AIAA Joint Propulsion Conference, Seattle, Washington, July 7-9, 1997, NASA TM-107504, July 1997.
- Steinetz, B.M.: 1991, "High Temperature Performance Evaluation of a Hypersonic Engine Ceramic Wafer Seal," NASA TM-103737
- Turnquist, N.A.; Bagepalli, B; Lawen, J; Tseng, T., McNickle, A.D., Kirkes; Steinetz, B.M., 1999, "Full Scale Testing of an Aspirating Face Seal", AIAA-99-2682.



NASA Glenn Research Center  
Seal Team