

A Characterization of Alcohol Fuel Vapor for Wavelength Modulation Spectroscopy Applied to Microgravity Flame Spread

Michael J. Kulis & Prof. David S. Perry

University of Akron, Department of Chemistry, 190 East Buchtel Commons,
Akron, OH 44325-3601

Fletcher Miller

National Center for Microgravity Research, NASA Glenn Research Center, MS 110-3,
Cleveland, OH 44135-3191

Nancy Piltch

NASA Glenn Research Center, MS 110-3, Cleveland, OH 44135-3191

Introduction

A diode laser diagnostic is being developed for use in an ongoing investigation of flame spread in microgravity at NASA Glenn Research Center. Flame spread rates through non-homogenous gas mixtures are significantly different in a microgravity environment because of buoyancy and possibly hydrostatic pressure effects. These effects contribute to the fuel vapor concentration ahead of the flame being altered so that flame spread is more rapid in microgravity [1]. This paper describes spectral transmission measurements made through mixtures of alcohol, water vapor, and nitrogen in a gas cell that was designed and built to allow measurements at temperatures up to 500 °C. The alcohols considered are methanol, ethanol, and n-propanol.

The basic technique of wavelength modulation spectroscopy for gas species measurements in microgravity was developed by Silver et al [2,3]. For this technique to be applicable, one must carefully choose the spectral features over which the diode laser is modulated to provide good sensitivity and minimize interference from other molecular lines such as those in water. Because the methanol spectrum was not known with sufficient resolution in the wavelength region of interest, our first task was to perform high-resolution transmission measurements with an FTIR spectrometer for methanol vapor in nitrogen, followed recently by ethanol and n-propanol. A computer program was written to generate synthesized data to mimic that expected from the experiment using the laser diode, and results from that simulation are also presented.

Experimental Apparatus and Procedure

In order to record alcohol spectra at low concentrations and elevated temperatures, we built a gas cell and fuel vapor filling system. The gas cell is a cylindrical stainless steel body with sapphire windows sealed at both ends using flanges and aluminum washers, Fig 1. The transmission path length is 9.83 cm. The cell can be heated up to 500 °C using a heating mantle wrapped around the cell. The heating mantle and cell are partially enclosed with ceramic plating. The temperature is displayed, set, and maintained using a temperature controller connected to the heating mantle and a thermocouple attached to one flange of the cell. A second thermocouple is welded through to the inside of the cell body (shown in Fig. 1) to accurately measure the temperature within the cell.

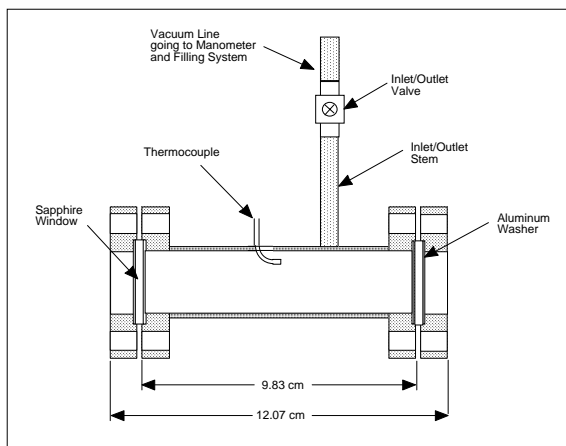

Fig 1. Gas cell without heating mantle and ceramic plating

The fuel vapor filling system is used to precisely fill the cell with alcohol vapor at the desired pressure while the cell is at the temperature at which the transmission will be recorded. The system and gas cell are evacuated for about thirty minutes to clear all inner surfaces from contamination of previous experiments. The alcohol vapor is introduced into the filling system and gas cell by opening one of the valves leading to a test tube containing alcohol in its liquid state and its corresponding vapor pressure at room temperature. The pressure in the cell is measured using a capacitance manometer on a vacuum line. The approximate error of the pressure measurement is 0.25 torr. The pressure is adjusted by partially opening the system to

vacuum. The inlet/outlet valve on the cell is then closed, and the capacitance manometer in addition with the vacuum line going to the cell is evacuated. Nitrogen is introduced into the system up to the inlet/outlet valve. Once the pressure of nitrogen is above the vapor pressure of the alcohol in the cell, the inlet/outlet valve is opened. The pressure in the cell is increased to approximately one atmosphere to give a pressure broadened spectrum that resembles a spectrum obtained in a combustion environment.

The spectra were obtained with a Nicolet Nexus 870 FTIR spectrometer over a range of 2100 to 8000 wavenumbers, with a resolution of 0.05 wavenumbers. The cell was specifically designed to fit inside the open sample compartment with its heating mantle in place. Ambient air was purged from cell windows with nitrogen to avoid interference with overlapping water lines in the alcohol spectrum.

Experimental Results

Spectra of methanol, ethanol, n-propanol and water recorded at 30 °C are shown in Fig 2 for a limited wavelength range that we determined had the optimal peaks for methanol detection. Each spectrum is normalized by its partial pressure and the pathlength in order to directly compare signal strengths with other spectra. Of the three alcohols, methanol provides the sharpest and most intense peaks. Along with alcohol concentration information, the spectra obtained for the experimental combustion system will contain overlapping water lines and also encode temperature information. Fig. 2 shows that methanol peak 1 has an overlapping water line that could be used for water concentration and/or temperature determination; methanol peak 2 has no overlapping water lines. As temperature dependence is weak, it may prove impossible to extract temperature reliably. A typical diode laser has a temperature tuning range of near 3 nm and a current tuning range of near 0.4 nm. Due to the thermal time constant, only current tuning is used during a given experiment, while temperature tuning can be used as a coarse adjustment in the set-up phase.

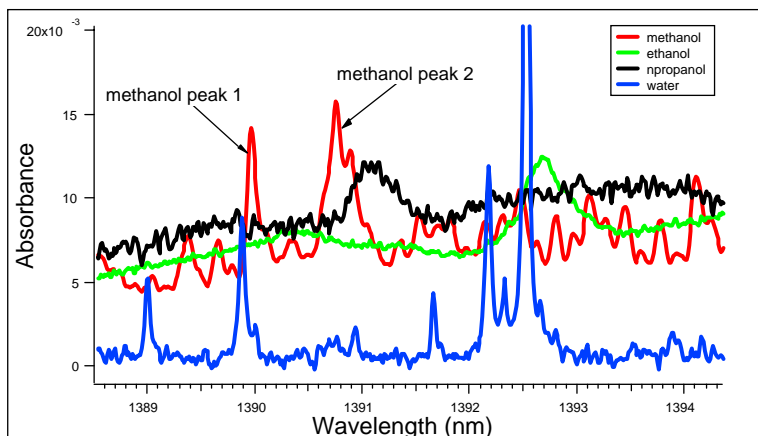

Fig 2. The first overtone OH stretch vibration of methanol, ethanol, n-propanol, and water per torr of pressure and per meter pathlength at 30 °C

In order to determine if the large methanol peaks shown in Fig. 2 are diagnostically useful, experimental spectra were recorded using the FTIR spectrometer in a range of conditions with temperature varying from 30 to 300 °C, pure methanol pressure from 10 to 70 torr, pure water pressure from 5 to 18 torr and select mixtures of the of two. Fig. 3 shows the concentrations of the species in each spectrum obtained at 30 °C.

Simulated Wavelength Modulated Spectra

The FTIR spectra were translated into wavelength modulation spectra with a routine designed to simulate the data acquisition of the diode laser system developed by Silver et al. This system uses a modulation frequency f , demodulated at $2f$, and modulation depth, which represents the amplitude of the applied modulation signal. Simulated $2f$ spectra of methanol are shown in Fig. 4 with modulation depths of 0.04 nm, and 0.06 nm. This figure illustrates that, for modulation depths small compared to the linewidth, increasing the modulation depth improves the signal to noise ratio [4].

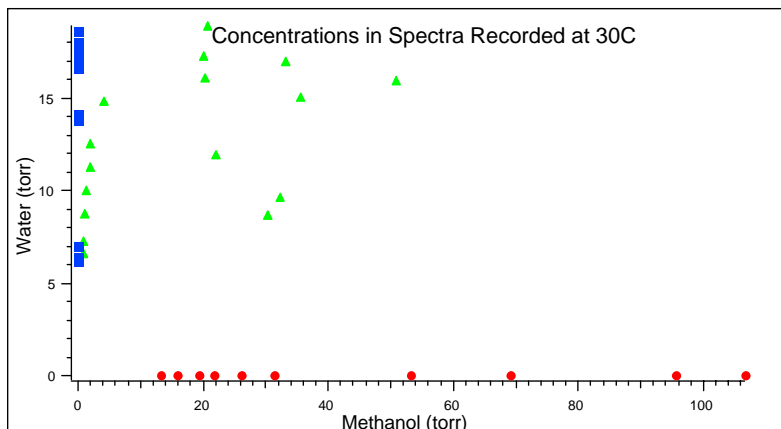

Fig. 3. Concentration of the methanol and water in each spectrum at 30 °C

The intensities of both peaks correlate well with methanol concentration; peak 1 correlates only marginally with temperature. Using the wavelength modulation technique, the detection limits of these peaks are expected to be near 10 ppm with a 10cm pathlength. The correlation with temperature may improve with the spectra obtained using the wavelength modulation technique. With this technique, the detection sensitivity is limited by the detector quantum noise instead of by laser $1/f$ noise, as is the case with direct absorption. The signal to noise for wavelength-modulation spectra is expected to be approximately three times larger than that for the FTIR spectra if the detector quantum noise limit is reached.

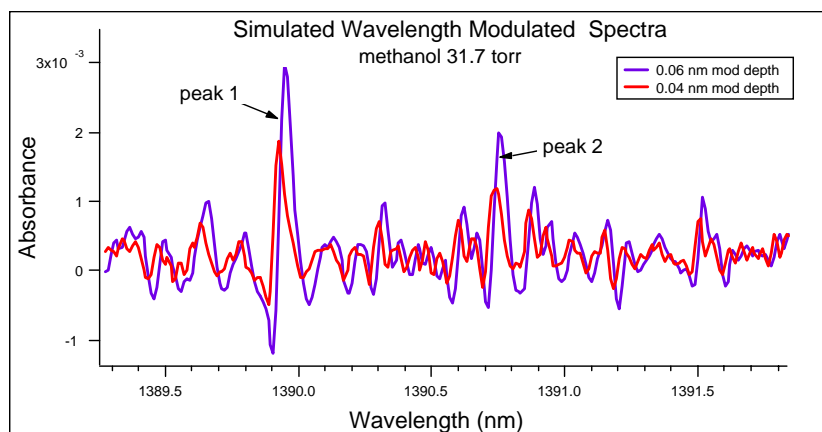

Fig. 4. Simulated $2f$ spectra from FTIR spectra.

obtained for vapor-phase methanol, water, and mixtures from 30 to 300 °C and various concentrations. From these measurements two methanol features were identified that show minimal interference from water and that have sufficient amplitude for detection by diode laser spectroscopy. Similar spectra were also recorded for ethanol and n-propanol.

A computer program was written to simulate wavelength-modulated diode laser spectra using the experimental FTIR spectra as input. The output is displayed as a $2f$ spectrum (that is, demodulated at twice the modulation frequency) and effects of varying the modulation depth were examined.

Acknowledgements

This research was supported by NASA grant NAG3-2512 to the University of Akron, a NASA Glenn GSRP Fellowship NGT3-52364 for Michael J. Kulis and a NASA NRA Award to the National Center for Microgravity Research.

References

1. F.J. Miller, J. W. Easton and A.J. Marchese, "Gravitational effects on flame spread through non-homogeneous gas layers," *Proc. Comb. Institute*, **29**, 2003 (to appear)
2. Joel A. Silver, Daniel J. Kane and Paul S. Greenberg, "Quantitative species measurements in microgravity flames with near-IR diode lasers" *Applied Optics*, **34**, 2787 (1995)
3. Joel A. Silver and Daniel J. Kane, "Diode laser measurements of concentration and temperature in microgravity combustion," *Meas. Sci. Technol.* **10**, 845 (1999)
4. Joel A. Silver, "Frequency-modulation spectroscopy for trace species detection: theory and comparison among experimental methods," *Applied Optics*, **31**, No. 6, 707, (1992)

Conclusions

In preparation for diode laser measurements of methanol for use in flame spread investigations, an extensive study of the spectra of methanol and water in the region of available diode lasers was performed. A heated cell was constructed to allow measurements of heated methanol vapor. High-resolution FTIR spectra were