

A General Overview of the Data Acquisition and Controls Systems (DACS) of the E-Complex at NASA's Stennis Space Center

Mark S. Hughes*, Phillip W. Hebert†, Dawn M. Davis‡ and Scott L. Jensen§
Propulsion Test Directorate, NASA John C. Stennis Space Center, Stennis Space Center, MS 39529, USA

and

Frederick K. Abell, Jr.¶
Data Reduction & Analysis Group, Lockheed Martin Stennis Operations, Stennis Space Center, MS 39529, USA

The John C. Stennis Space Center (SSC) provides test operations services to a variety of customers, including NASA, DoD, and commercial enterprises for the development of current and next-generation rocket propulsion systems. Many of these testing services are provided in the E-Complex test facilities composed of three active test stands (E1, E2, & E3) and 7 total test positions. Each test position is outfitted with unique sets of data acquisition and controls hardware and software that record both facility and test article data and enable safe operation of the test facility. This paper addresses each system in more detail including efforts to upgrade hardware and software.

I. Introduction

The E-Complex data acquisition system (DAS) is actually composed of two separate systems, one for static data and the other for dynamic data. The static DAS is known as the Low-Speed DAS (LSDAS). The dynamic data acquisition system is known as the High-Speed DAS (HSDAS). For each system, data is recorded remotely in the Test Control Center (TCC). The TCC's LSDAS real-time display can be viewed in tabular as well as graphical format. QuickLook data for the HSDAS is available shortly after test completion.

The E-Complex control system handles the transfer of propellants to storage and run tanks, temperature ramping, valve sequencing, operation of pumps and vaporizers, and pressurization of tanks. The control system provides a real-time display of operations in a process format. It contains a general, automatic, time-based sequencer that can be configured for test article specific test operations. A hardwired Emergency Shutdown System enables manual override of the control system to shut down the facility and associated test article systems in a predetermined, timed sequence should the primary control system fail.

The Data Acquisition and Control Systems (DACS) are supported by a separate off-stand DACS Lab where hardware and software system development and troubleshooting are conducted. Test facilities do not have to be taken offline to address a problem or validate a system change.

II. HSDAS

The Racal Storeplex is the heart of SSC's E-Complex HSDAS. This multi-channel high-speed data recording system is comprised of two fundamental components, the Storeplex Tape Transport Unit (TTU) and the Signal Processing Unit (SPU). Ancillary functions such as configuration control and TTU to SPU communications are provided by computer interface and a fiber optic transceiver system, respectively. Post-test data processing of high-speed data is accomplished by the High Speed Data Processing System (HSDPS) which will be discussed later.

* Electrical Design Lead, Mail Stop VA30E, AIAA Member.

† Electrical Operations Lead, Mail Stop VA21.

‡ Electrical Design Lead, Mail Stop VA30E.

§ DACS Laboratory Lead, Mail Stop VA30E.

¶ Data Reduction Analyst

A. Architecture

The block diagram in Fig. 1 represents a typical architecture for 128 channels of HSDAS in an E-Complex test facility. The TTU is located in the TCC for personnel safety and protection of test data. Since the TCC is not immediately adjacent to the Signal Conditioning Building (SCB) where the SPU resides, the standard Racal coaxial interface is not used. Data in Racal's proprietary format is transmitted over a long distance fiber optic duplex data communications link provided by Omni Technologies, Inc. (OTI). The OTI FOTR-125 extends the TAXI (transparent asynchronous transceiver interface) serial bus link between the Racal front-end and the recording unit. Two transmitters and two receivers are employed at each end of the link with automatic or manual switchover to maximize the reliability of the communications.

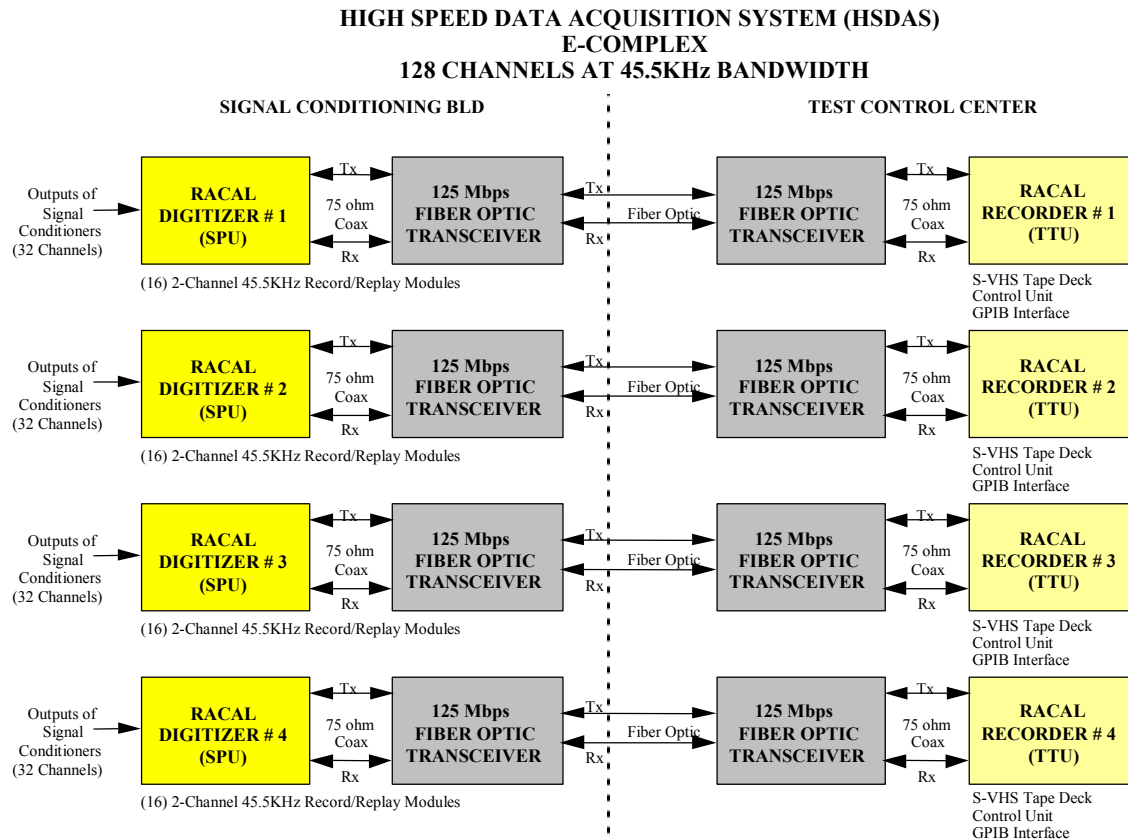

B. Recording System

The high-speed recording system is controlled manually through the TTU Control Unit. From the TTU Control Unit, test personnel are able to start and stop the TTU for test. They can replay taped data post-test if desired.

The TTU records high-speed digitized data to Super VHS tape for up to 32 channels at 100,000 SPS of 16 bit data with a 45.5 KHz bandwidth. Therefore, the aggregate Storeplex data rate is 50 Mbps (6.4 MB/sec). Reducing the sample rate also reduces the bandwidth accordingly. For example, sampling at 50,000 SPS reduces the bandwidth to 22.75 KHz. The full tape recording capacity is 22 Gbytes of high-speed data.

In addition to the IEEE-488 and TAXI out Tx/Rx interfaces, the TTU has connections for TTL remote, RS-232, SCSI-2, and pre-trigger buffer.

The HSDAS front end SPU resides in the SCB directly beside the test stand. After signal conditioning (if required), dynamic instruments are connected to the SPU input terminals using standard coaxial cables. Analog data is converted to digital and sent through the coaxial output of the signal-processing unit where it is converted to fiber and transmitted to the TTU.

Each SPU has 16 slots which are capable of utilizing almost any combination of channel modules. Modules currently on hand in the E-Complex contain 1, 2, and 4 channels each. Thus, a maximum of 64 channels can be

configured for a single SPU but only at the reduced sample rate of 50, 000 SPS. The E-Complex has standardized on the 2 channels per module arrangement in each SPU slot creating a 32 channel configuration at 100,000 SPS data rate. IRIG-B timing does occupy one of the 32 channels for timing correlation thus reducing the actual available channels to 31.

Once channel modules have been identified, connector panels to match or blank off (store) channels must be selected. A few channel module and connector module combinations are limited by power consumption. Combinations require power use evaluation prior to installation to prevent overheating of electronics. One drawback of the Racal SPU is the inability to provide a hot-swapping capability.

Output gain on the channel modules can be set from 1 to 128 as a power of 2 for a DC input and 1 to 32 as a power of 2 for an AC input. Inputs can be AC or DC coupled. Anticipated maximum input voltage levels can be set to .5, 1, 2, 5, 10, 20, 50 Volts peak. Each module uses Sigma-Delta A-to-D conversion with 64 times over-sampling (inputs are initially sampled at 6.4 MHz) meaning aliasing frequencies are much higher reducing the filtering requirement. Only one simple 2nd order Butterworth anti-aliasing filter is required to cover all channel operating bandwidths.

The E-Complex is currently investigating commercial systems for replacement of the Racal Storeplex HSDAS with mature market technology. Focus is on commercial off-the-shelf equipment with open architecture and integrated software. An "indefinite delivery, indefinite quantity" contract, which would allow complete replacement of all Racal Storeplex units, was issued at SSC in early June. An initial 32 channel system is being procured for rigorous testing in parallel with existing systems for comparison. Should the new system evaluation prove successful, a five year program for replacement of the existing HSDAS will be undertaken.

III. HSDPS

The High-Speed Data Processing System (HSDPS) produces verifiable propulsion test data by following a strict process for receiving, processing, delivering, and archiving test data. Digital data is received (transferred) via Super VHS tapes to the HSDPS as shown in Fig. 2. Later, during data processing, the high-speed data is generally filtered and sub-sampled. The HSDPS then converts the raw digital data to scaled (Engineering Unit) Fast Fourier Transforms (FFT) coefficients for frequency analysis. A QuickLook dynamic analysis program is available for data reports and evaluation. Sub-sampled time domain data can be provided in Winplot (A NASA created data plotting software package) format. Data backup is provided on CD-ROM for FFT data and SVHS tape for raw dynamic data. FFT data and even raw data can be transferred offsite to the customer if desired.

A. Computers

Two Hewlett Packard Unix workstations, HP J5000s, were the backbone of the data reduction and analysis (DR&A) process due to their reliability, versatility, security, and ability to multitask. Each workstation had 2 RISC processors, 1-2 Gigabytes of RAM, 36+ Gigabytes of secondary storage, and operated with the HP-UX 11.0 (Hewlett Packard Unix) operating system.

Three HP J6750 computers were procured in May 2004. They replaced the J5000 systems in mid-June after a rigorous verification process. Each HP J6750 has twin 875 MHz RISC processors, 4 Gigabytes of RAM, and 72 Gigabytes of secondary storage. Each HP J6750 has its own firewall and security monitoring system.

In addition to the new workstations, personal computers are used for minor utility functions and archiving. Two HP 5Si laser printers and one Epson Photo 700 inkjet color printer are used for data plots and CD-ROM labels.

B. Network

The Racal HSDAS Tape Transport Units in the E1, E2, and E3 control rooms are physically isolated from the DR&A computers. Post-test, high-speed data is stored on certified SVHS tapes. They are hand delivered to DR&A personnel who place the certified tapes in Storeplex TTUs that are directly connected to the Unix workstations via SCSI connection where the data processing and offsite transmission take place.

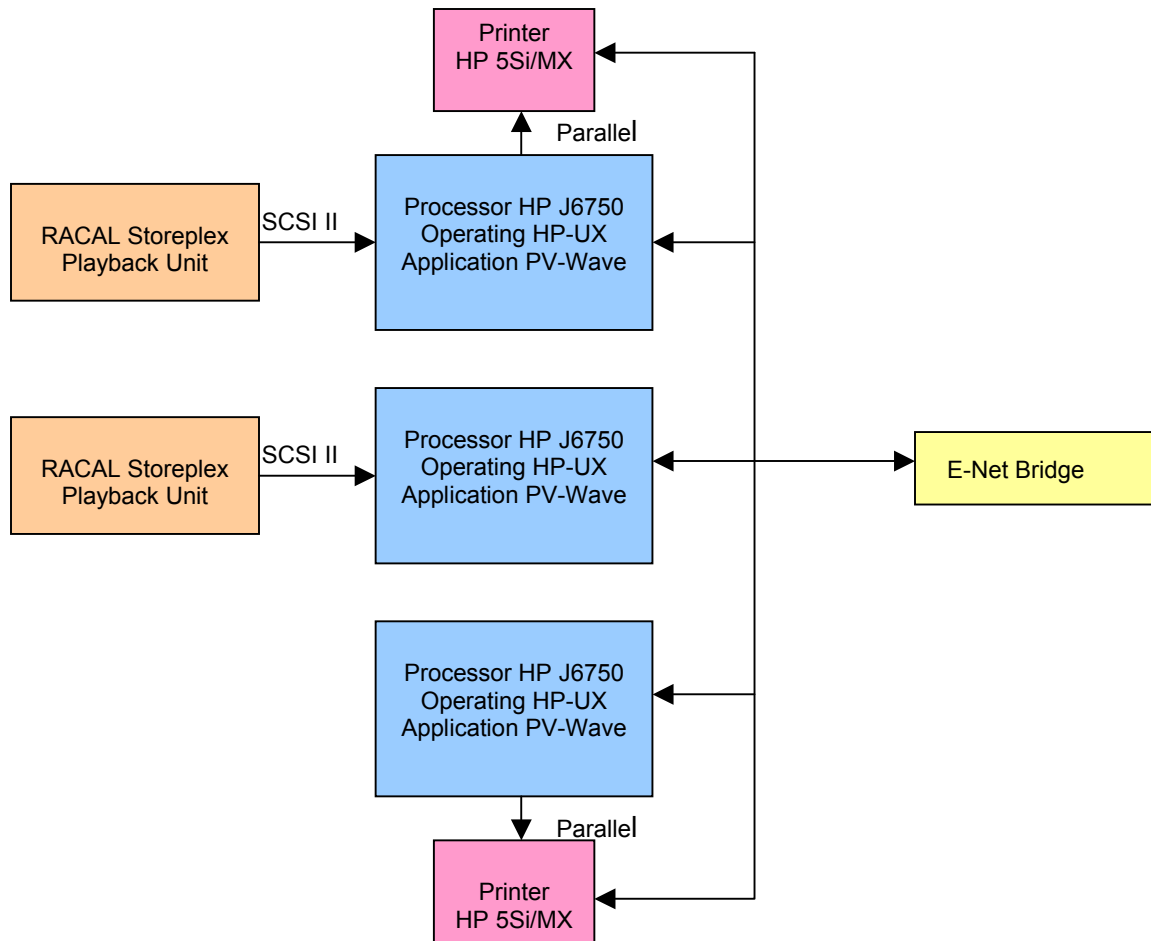

Figure 2. High-Speed Data Processing System (HSDPS).

IV. LSDAS

The LSDAS, as seen in Fig. 3, consists of a system controller (personal computer) connected to a Tustin Collector (CCIS) by a General Purpose Instrumentation Bus (IEEE 488) in each test facility's TCC which in turn is connected via fiber to the Tustin front-end hardware located in the SCB. This hardware includes a Tustin Master Multiplexer with its Slave Multiplexers and Discrete Input units. The Master and Slave Multiplexers are used for analog input signals in the range of 0-10V. Typically these input signals come from the filtered outputs of the Pacific 9355 programmable signal conditioners and Pacific 70A manual filter amplifiers located in the SCB.

A. Signal Conditioning and Other Inputs

The programmable signal conditioners are most often used with measurements requiring excitation and bridge completion. Parameters such as gain, excitation, and filter settings along with other setup information are programmed into the signal conditioners using the system controller in the TCC through the IEEE 488 interface. The programmable signal conditioners contain one filtered output and two unfiltered outputs. The filtered output is wired to the LSDAS. The unfiltered outputs go to the control system and the HSDAS if needed.

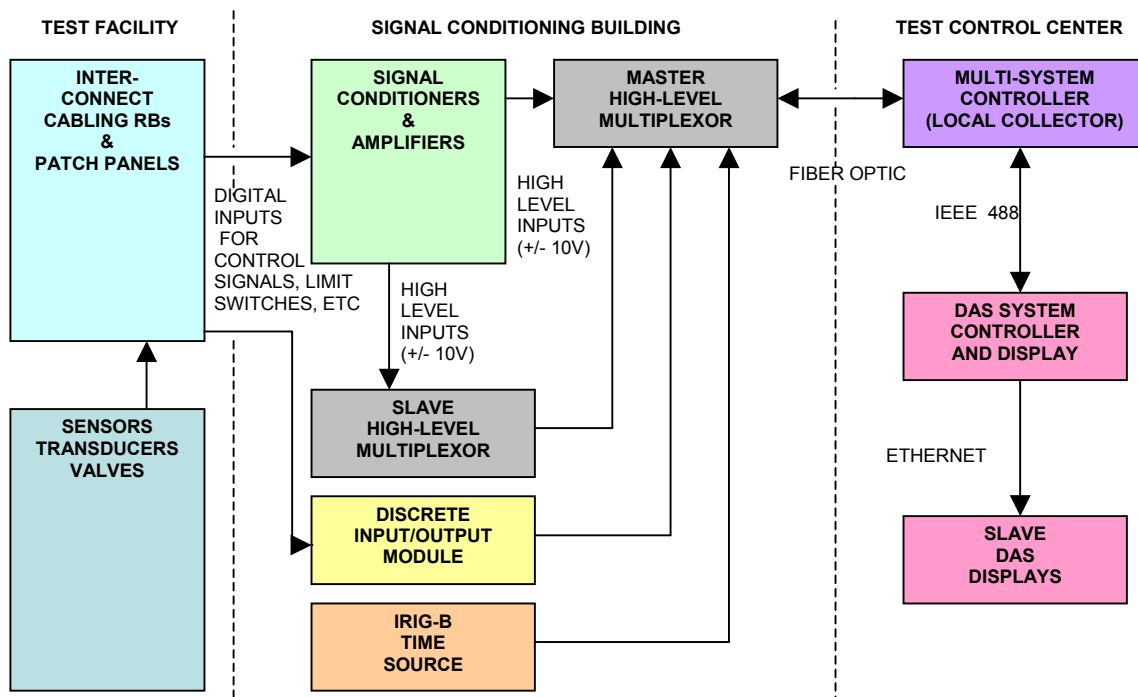

Figure 3. LSDAS Block Diagram.

The manual filter amplifiers are used for sensors that generate their own signal without excitation such as thermocouples. In addition, analog inputs from the control system, such as valve positions are wired through the manual filter amplifiers.

The master multiplexer has provisions for IRIG-B time code input. IRIG B is used to time stamp the data for correlation with other data systems such as the HSDAS and the video monitoring system. This is most useful when unusual events occur and a complete timeline is needed for understanding.

The Discrete Input units are used for digital input signals, typically from the control system. They are useful in determining valve timing and in validating test sequencing.

B. E1 Architecture

The E1 test stand is the largest of the three E-Complex test facilities. It contains four separate data systems: one for each of its three test cells and one for the facility. All four of the data systems are configured for 512 analog input channels and 320 discrete channels. In addition, the test cells can provide up to 470 filtered analog channels with 320 programmable channels and 150 manual filter amplifier channels. The E1 LSDAS can sustain sampling burst rates of 2 microseconds. This is equivalent to sampling 2000 channels at 250 SPS.

C. E2 Architecture

The E2 Test Stand contains two separate LSDAS systems in support of its two test cells. They are configured to maintain a burst rate of 8 microseconds. This is equivalent to 500 channels at 250 SPS. The E2 LSDAS systems multiplex inputs from both facility and test cell measurements. There are 400 analog channels and 420 discrete channels.

D. E3 Architecture

The E3 Test stand LSDAS contains 400 analog channels and 312 discrete channels in a single system supporting activities in both of its test cells and facility. In addition, the CCIS unit at the E3 TCC has been modified to use two separate IEEE 488 connections. The first carries the normal flow of data to the CCIS and the second reduces the time it takes to monitor redline conditions in the control system.

E. Graphical User Interface

The LSDAS uses a LabVIEW Graphical User Interface (GUI) for control. The GUI provides access to numerous setup parameters in the Tustin including sample rate, channel sample list, real-time data display in both tabular, as shown in Fig. 4, and graphical form, and data archiving. Real-time data is broadcast within a secure network using the User Datagram Protocol (UDP) for remote display on computers within the TCC at an update rate of 5 samples per second.

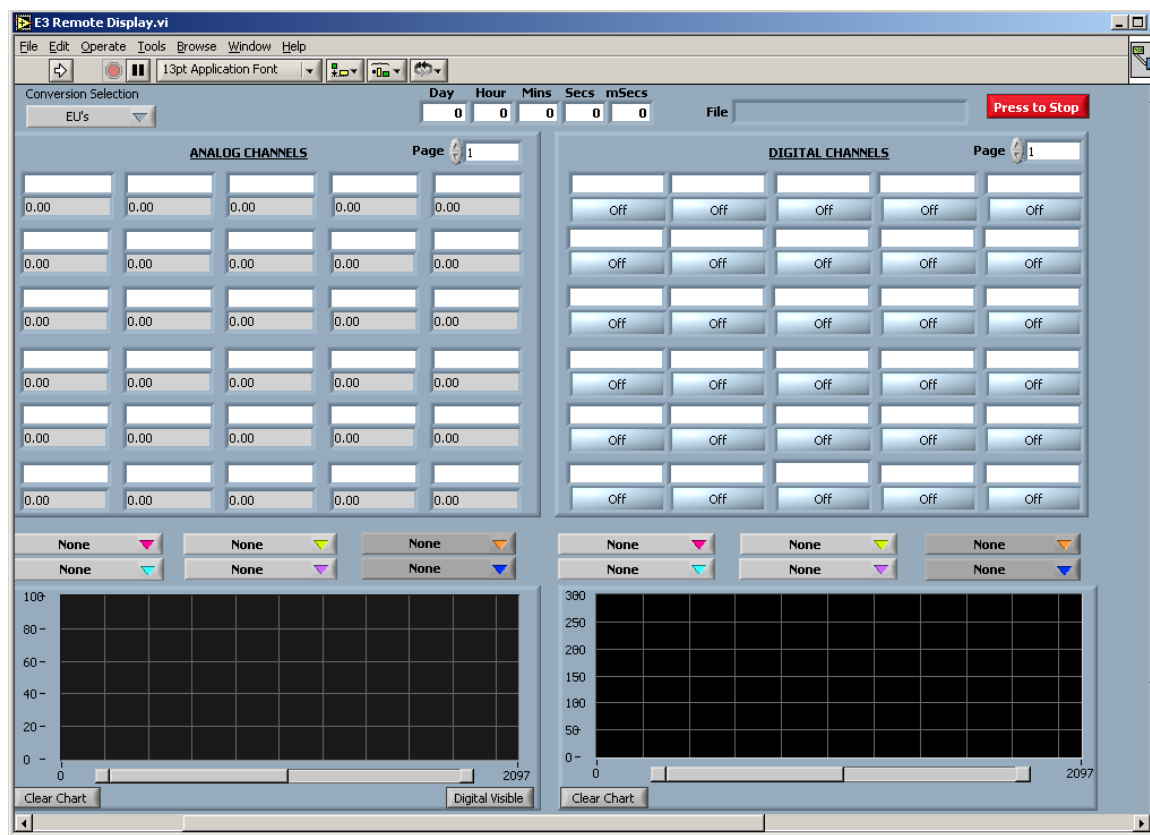

Figure 4. LSDAS GUI – Data Display.

F. Operational Modes

The LSDAS has several operational modes including pre-test, test, post-test, standby, and display. In test mode, the data is available for display at a maximum rate of 5 samples per second. Data is sampled and saved directly to the hard drive at the defined test sample rate, nominally 250 samples per second. In the pre-test and post-test modes, data is also available for display at a maximum rate of 5 samples per second. Data is sampled and saved directly to the hard drive at the defined pre-test or post-test sample rate, nominally 50 samples per second. The sample rates of the pre-test and post-test modes are set such that these rates may be achieved by decimating the data sampled at the faster test sampling rate. In standby mode, data is sampled and saved at a rate of 1 sample per second. This mode is used primarily for 24/7 data logging. Finally, display mode, as seen in Fig. 5, is available for display at a rate of 5 samples per second. No data is stored to file. Display mode is used primarily for system setup. All these modes are easily accessed through the GUI. Transition to the different modes is dependent on the current state or mode of the LSDAS and only legal transitions are allowed. The hardware, or data acquisition, is not stopped during any of these transitional states.

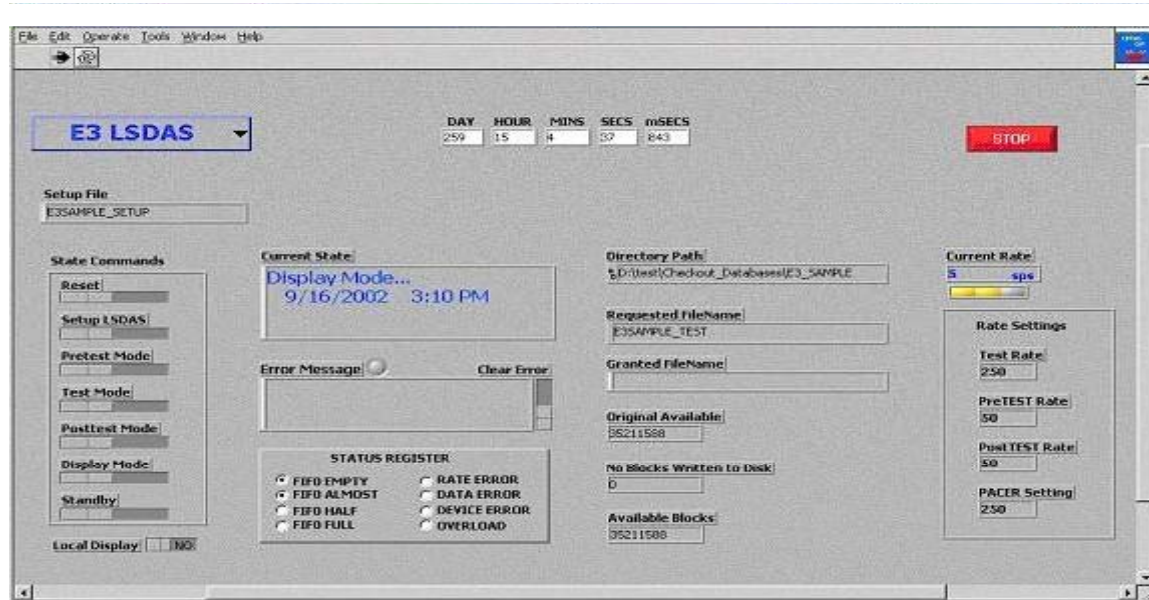

Figure 5. LSDAS GUI Front Panel (Display Mode).

G. Calibration

Every analog channel is calibrated prior to testing. Calibration is the process of setting or correcting a measuring device, usually by adjusting it to match or conform to a dependably known and unvarying measure. The calibration process used in the E-complex compares the output signal from the LSDAS against a known input signal. It provides a means of measuring system integrity and system repeatability. The devices contained on a typical calibration bus are shown in Fig. 6. All devices are wired through the IEEE 488 bus and are controlled by the system controller in the TCC. Each measurement on the LSDAS is calibrated by shunt calibration or voltage insertion. Shunt calibrations are used for sensors with bridge circuits such as pressure transducers and strain gauges. Voltage insertion calibrations are reserved for the rest of the measurements and sensors wired to the LSDAS through a signal conditioner or manual filter amplifier.

During the shunt calibration process, a shunt resistor (usually in the transducer) is used to create a known bridge unbalance. The equivalent voltage associated with the bridge unbalance is known (NIST traceable) and has been verified through the metrology laboratory at Stennis Space Center. The voltage recorded during the shunt calibration process is compared to this known voltage value and verified to be within a preset tolerance band. The shunt calibration data values are also checked for repeatability to ensure system precision. Channels falling outside of the tolerance band are flagged for further diagnostics and ultimately replacement.

During the voltage insertion calibration process, a known voltage is inserted into the signal conditioner channel from a NIST traceable, calibrated voltage standard. Typically, voltage values are selected to simulate 20% and 80% of the sensors output range. The output of the voltage calibration is recorded and compared against the known voltage value and verified to be within a preset tolerance band.

The calibration software is controlled through a LabVIEW GUI. The GUI, as shown in Fig. 7, offers several options in addition to the shunt and voltage insertion calibration processes. From the front panel, the user can select "setup" for the signal conditioners or the user can perform an autobalance or a frequency calibration. The "setup" option is only an option for channels wired to the programmable signal conditioners. The autobalance option may only be selected for channels connected to the programmable signal conditioner and used on instruments with bridge circuits. If this option is selected, the signal conditioner balances the bridge assuming the current value is zero. Frequency calibration is utilized to check the filter response of the amplifier. A sine wave at three different frequencies equivalent to $0.1f$, f , and $10f$ is inserted into the amplifier channel, where f is the filter setting of the filter, or the cutoff frequency. The dB roll-off is calculated and verified to be within the specifications for the filter response.

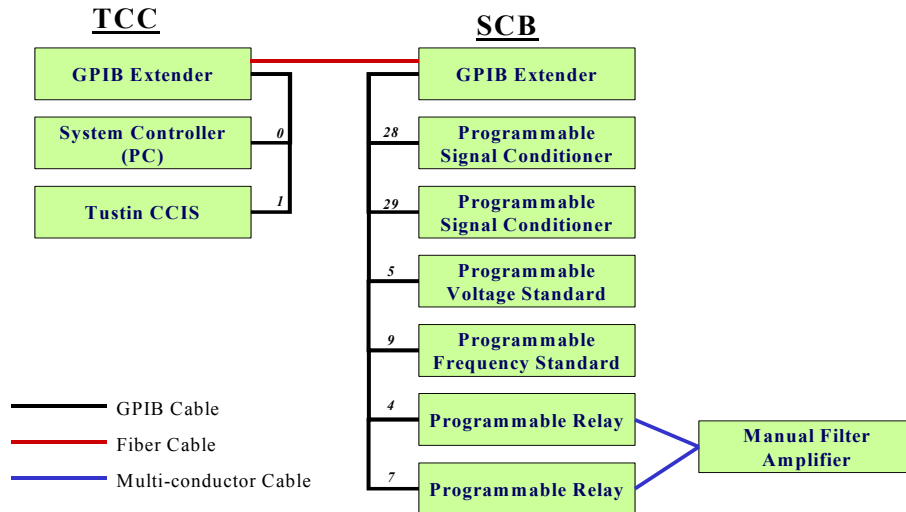

Figure 6. Typical Calibration GPIB Bus.

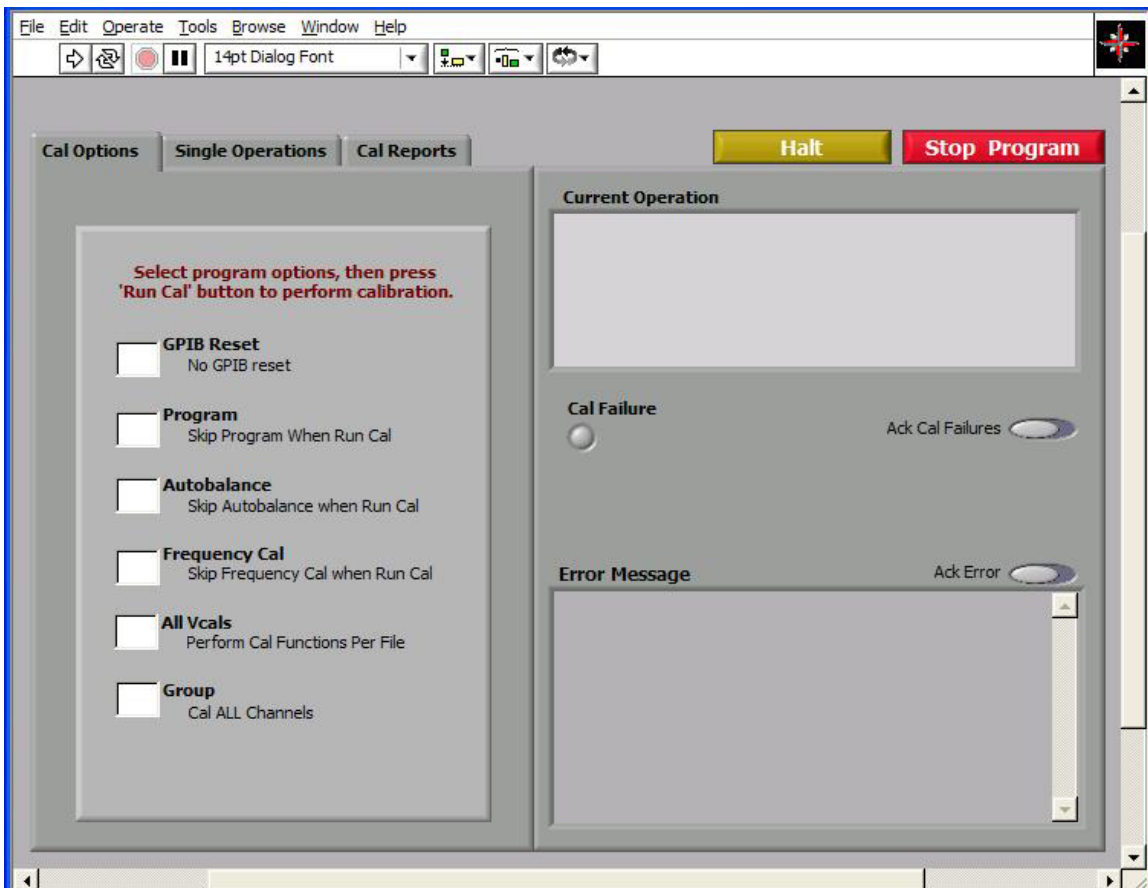

Figure 7. Calibration Program GUI.

H. Measurement System Analysis (MSA)

Currently, activities are underway to improve the accuracy and precision of the LSDAS in the E-Complex. This includes the installation of a systematic procedure for performing a Measurement System Analysis as seen in Fig. 8. The purpose of the MSA is to quantify a system precision for the LSDAS and therefore determine the acceptability of the system through a statistical analysis of the system. MSA software for the E-complex has been developed utilizing existing tools developed by the Boeing Co. in support of Space Shuttle Main Engine testing at Stennis Space Center. During the MSA process, calibrations are performed on the entire data system every hour for eight hours. This simulates the maximum time lapse between the performance of a pretest calibration and the actual test. From this data, the system drift over time may be determined and the overall system precision is calculated as a function of the transducer precision and the recorder precision. This eight-hour process is to be performed every 30 days as a minimum. Data from previous runs of the MSA software are used to generate the system precision and to maintain a history of the data system's response in calculating system drift over time.

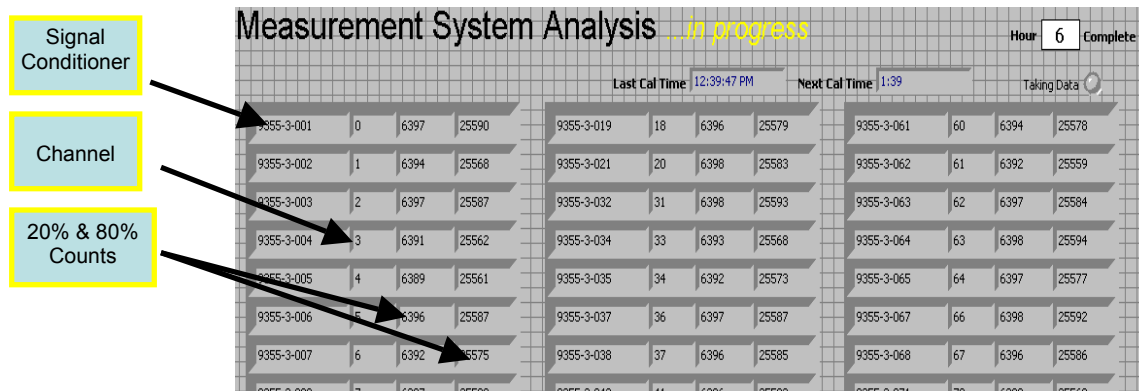

Figure 8. Measurement System Analysis Screen.

I. Remote Data Transfer (PCGOAL)

Gateway computers running Personal Computer Ground Oriented Aerospace Language (PCGOAL) have the ability to transmit data off-stand and off-site after receiving it from designated DAS Hub computers in each control room. The gateway computers, using the UDP protocol, form the bridge between the isolated internal network and an outside network. The PCGOAL software also provides the capability for supplying real-time data to the NASA created WinPlot application which can be used in the control rooms to supplement the LSDAS remote displays.

J. LSDAS Data Processing System

The LSDAS data acquisition computers in the E1, E2 and E3 control rooms are located on a physically isolated internal network. After test, data sets from these systems must be transferred to the DR&A computers via removable storage for processing and offsite transmission.

V. Controls

Programmable Logic Controllers (PLCs) form the backbone of the control systems in the E-Complex. Their primary function is to sequence rocket engine tests in a safe manner. During sequencing operations, PLCs provide on/off control for motor valves and open-loop/closed-loop control for variable-position valves.

Closed-loop valve operation employs the Proportional, Integral, and Derivative (PID) function in concert with a downstream transducer such as a pressure, LVDT, or a temperature as feedback. In open loop control, the variable-position valve is commanded to a preset position without feedback. Valve commands and feedback signals are always recorded on the LSDAS.

Once a valve releases energy into a system by pressurizing a tank or flowing cryogenics into pipe or tank, safety of personnel and test facility hardware including the test article, becomes paramount. Control system interlocks are employed to address some of these concerns. Interlocks prevent mechanical devices from actuating based on established criteria.

Safety concerns are also addressed by redlines and bluelines. Bluelines are measurement limits set to prevent a test system from advancing into a test sequence if the measurement parameters fall outside their anticipated values. They are only active prior to T=0. Once a test has reached T=0, redlines take over. Redlines are measurement limits set to prevent an engine test from damaging hardware or harming personnel. Redline violations will terminate a test.

A successful test means the PLC executes its preset shutdown sequence to safe the test facility and test article. If a test aborts abnormally due to exceeding a redline measurement, the PLC-based control system still executes its preset shutdown sequence. If the PLC faults, it is augmented by an emergency shutdown system of hardwired controls as the last line of defense. Power is removed from the primary control elements in a pre-determined sequence to minimize damage to the test facility and ultimately the test article. Valves may be slewed to closure depending on the type of valve and its importance.

A. E1 Architecture

The E1 Test Facility uses twelve (12) distributed PLCs, as shown in Fig. 9, for controlling the facility, special test equipment (STE) and Test Article functions. STE includes the hardware such as valves, piping, instrumentation and controls that form the bridge between the facility and the test article. Allen-Bradley SLC – 5/05 PLCs are used throughout E1 with the exception of a newly installed Allen-Bradley Control Logix PLC.

The E1 PLCs are located in the Signal Conditioning Building (SCB) which is integrated into the test stand hardware. The input and output modules are contained within each of the respective PLC cabinets. All twelve of these PLCs communicate via Ethernet.

The E-1 Control Room is located several hundred feet from the test stand in a building called the Test Control Center. There, a Windows 2000 workstation provides programming services for all PLCs using RSLogix 500 for the SLC-5/05 PLCs and RSLogix 5000 software for the ControlLogix PLC. The E1 control room also houses several workstations with Graphical User Interface (GUI) terminals using software called InTouch Factory Suite by WonderWare. The test conductors and system engineers use the workstations to monitor conditions of mechanical systems and to perform tests. Each GUI terminal communicates with other GUI terminals and PLCs by Ethernet. A diagram of the system is shown below in Fig. 9.

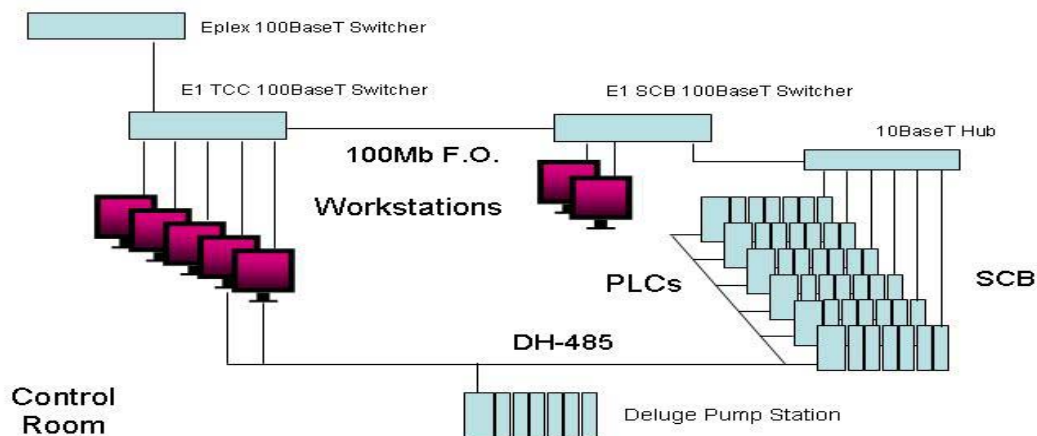

Figure 9. E1 Control Architecture.

B. E2 Architecture

E2 consists of two test cells physically separated by almost 400 feet of distance. E2 Cell 1 serves horizontal test articles while E2 Cell 2 serves vertical test articles.

Each cell utilizes two PLCs, one for facility and the other for STE and test articles. E2 PLCs are Allen Bradley model PLC-5/80C. Unlike E1, E2 PLCs are located in the E2 Control Room. The input and output modules are

located in one of three SCBs, co-located with the test cells. SCB1 and SCB2 are dedicated to E2 Cell 1, while SCB3 is dedicated to E2 Cell 2. The PLCs and the input and output modules in the SCBs communicate via ControlNet.

The E2 Control Room is located several hundred feet from the test cells and their respective SCBs and is actually adjacent to the E1 Control Room. A Windows 2000 workstation resides in the E2 control room serving a similar function as the E1 workstation. A diagram of the system is shown in Fig.10.

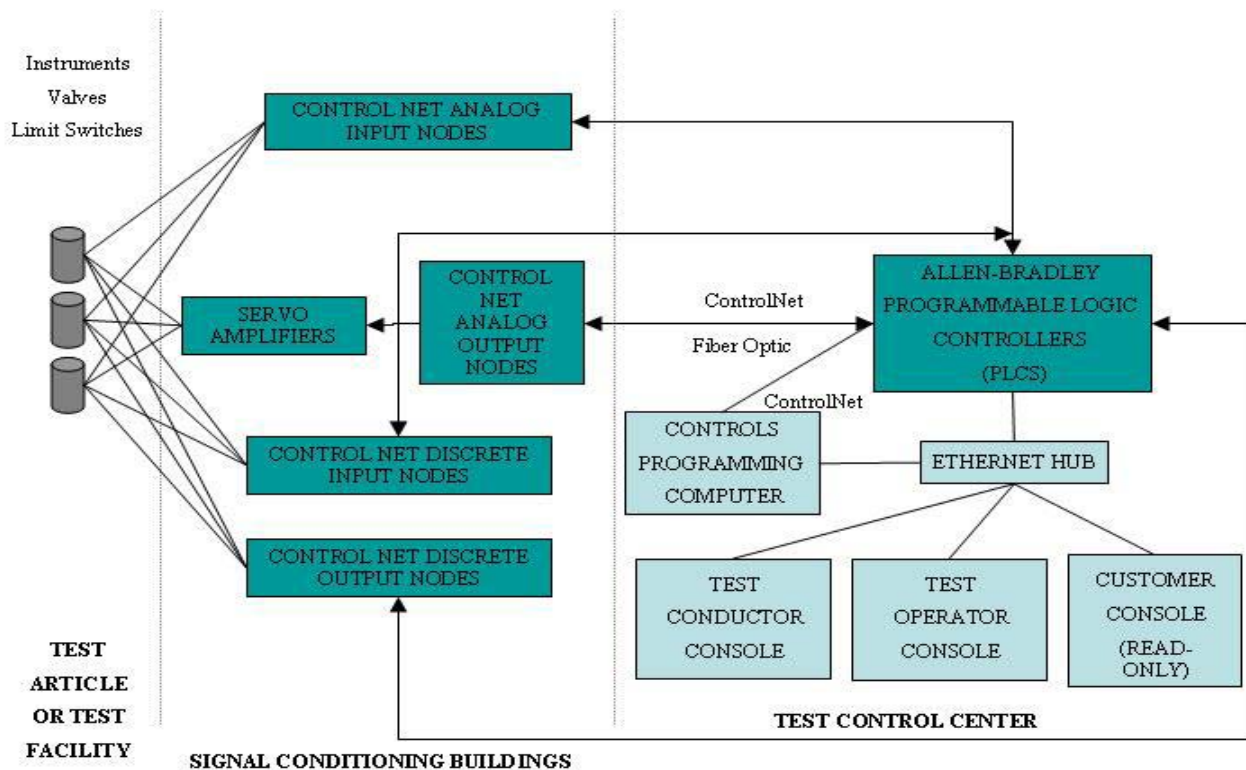

Figure 10. E2 Control System Architecture.

C. E3 Architecture

Test Stand E3 also consists of a vertical and a horizontal test position but these are adjacent to each other. E3 uses a single Allen-Bradley PLC-5/80C PLC. The PLC is dedicated to controlling the test stand and test article. The PLC is located in the SCB, while a Windows 2000 workstation is located in the Control Room. The input and output modules for the PLC are located in the E3 SCB. Communication between the PLC and its input and output modules in the SCB is performed via ControlNet.

The E3 Control Room is located near the E1 and E2 control rooms. Its configuration is similar to E1 and E2, containing several workstations with Graphical User Interface (GUI) terminals and software. The single largest difference between E2 and E3 control architectures besides the location of the PLC is the addition of a Redline PC in the E3 Control Room which is used to help reduce control loop time for Redline measurements.

D. Sequencers

Each PLC contains coding for a time-based sequencer that regulates how the mechanical systems (valves, pumps, motors, pressurization systems, etc.) operate. The sequencer also monitors test termination decisions where measurement limits are enabled and disabled on a timed sequence. Upon completion of the pre-programmed sequence (test completion) or a violation of a measurement limit (redline), a test is terminated.

Sequencers are essentially a table of events which define how a rocket engine or component test is to be executed. Sequencers are typically defined in a Microsoft Excel spreadsheet, are time based, and are downloaded to the PLCs using RSLinx software. For instance, step 1 may be defined as T=25 seconds in which certain valves will be exercised as well as blueline limits set. Step 2 may then be defined as T=0, which defines “test start”, in which a different set of valves are exercised and redline limits set. A sample sequencer is shown in Fig. 11.

				Manual Ramp Rate Down: 100%/sec
+	+	Preburner Oxidizer ByPass Valve	VPV-10F26-LO	Manual Ramp Rate Up: 100%/sec
				Manual Ramp Rate Down: 100%/sec
+	+	10" FAC LOX Prevalve	VPV-10F18-LO	Manual Ramp Rate Down: 100%/Sec
1.25	-26.75	HPLH Tank 3" Vent	PCV-10A24-GH	Position Set Point: 0%
+	+	HPLH Tank 6" Vent	MV-10A83-GH	Close
+	+	HPLH Tank 1" Vent	MV-10F23-GH	Close
+	+	LH Transfer Valve	MV-10A74-LH	Close
+	+	LH Transfer Valve	MV-10A75-LH	Close
+	+	LH Transfer Valve	MV-10F85-LH	Close
+	+	LH Transfer Bleed Valve	MV-10A76-LH	Open
+	+	HP LOX Tank 3" Vent	MV-10A28-GO	Close
+	+	HP LOX Tank 6" Vent	MV-10F08-GO	Close
+	+	HP LOX Tank 1" Vent	PCV-10A03-GO	Position Set Point: 0%
+	+	LOX Transfer Valve	MV-10A25-LO	Close
+	+	LOX Transfer Valve	MV-10A23-LO	Close
+	+	LOX Transfer Valve	MV-10A32-LO	Close
+	+	LOX Transfer Bleed Valve	MV-10A24-LO	Open
+	+	4" LOX Bleed	VPV-10F01-LO	Position Set Point: 0%
2.50	-25.50	HPLH Tank 6" PCV	PCV-10A23-GH	Auto Control
				PID: 20, 0.05, 0
				Auto Ramp Rate Up: 20 psi/sec
				Pressure Set Point: 0 psig
+	+	HPLH High Point Bleed Valve	VPV-10F12-LH	Position Set Point: 0%
+	+	HP LOX Tank 6" PCV	PCV-10F03-GN	Auto Control
				PID: 14, 0.03, 0
				Auto Ramp Rate Up: 20 psi/sec
				Pressure Set Point: 3800 psig
8.50	-19.50	TEA/TEB Run Tank Pre-press	SV-10A3359-TT	Open
+	+	HP LOX High Point Bleed Valve	VPV-10F14-LO	Position Set Point: 0%
12.50	-15.50	HPLH Tank 6" PCV	PCV-10A23-GH	Auto Ramp Rate Up: 100 psi/sec
+	+	HP LOX Tank 6" PCV	PCV-10F03-GN	Auto Ramp Rate Up: 100 psi/sec
18.00	-10.00	HP LOX STE Main Purge Valve	MV-10F38-GN	Open
+	+	HPLH STE Main Purge Valve	MV-10A2323-HE	Open

Figure 11. Sequencer Example.

E. Graphical User Interface

Graphical User Interfaces are active control room displays that test conductors use to monitor mechanical systems during facility and test operations. These displays are also used by the test conductors to run the tests. The GUI displays are programmed using InTouch software. Manual valve operations and other activities such as entering blueline and redline limits are performed using the GUI. An example of a GUI screen is shown below in Fig. 12.

As was mentioned above, manual valve control is available through the GUI at each test stand. An operator can simply click on a valve icon to exercise the valve. A pop up window requests verification of the operator’s action. Once the operator confirms the action, the control system moves the valve to the desired state. In the case of a variable position valve, several other options, such as the valve ramp rate and the desired position of the valve (% OPEN or CLOSED) are available to the operator.

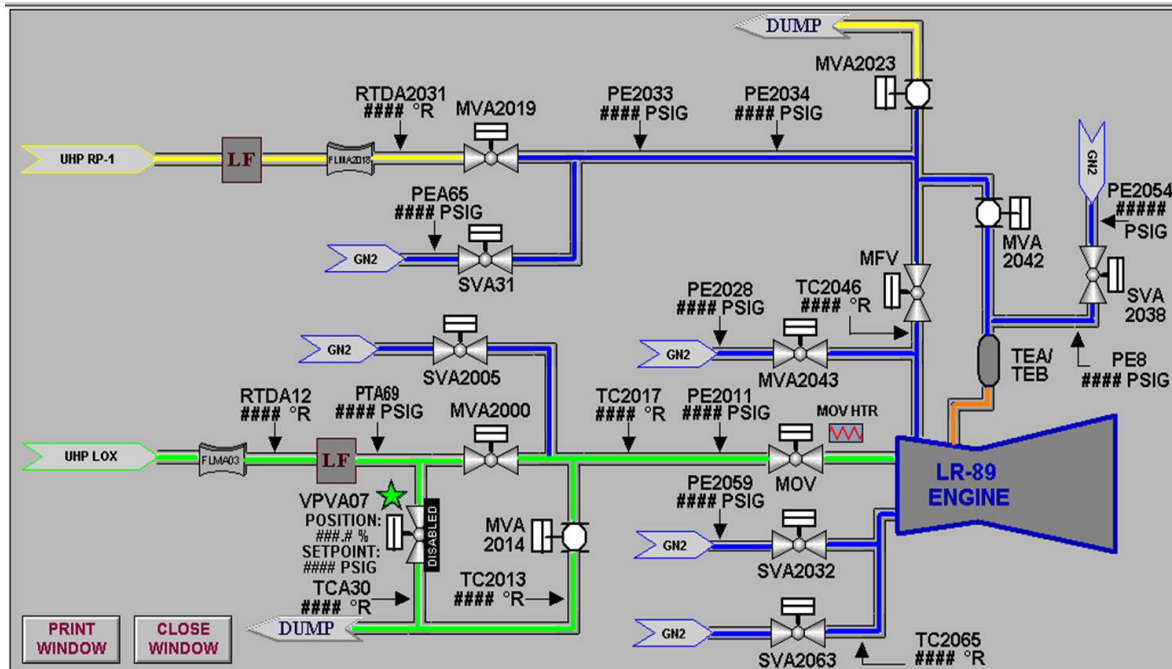

Figure 12. Controls GUI Example LR89 Project.

F. Valve Tuning

Tight control values and tolerances can vary significantly between test programs, therefore careful tuning of these systems is required. The tuning process can be quite time consuming and require large amounts of propellants over several activations to achieve optimum performance. Thus, a successful test requires exceptional coordination between the test conductor and the controls engineer.

Tuning of a valve often requires initial checkouts of the valve's manual operation. The appropriate valve position feedback signals to the control system must be determined. Once the valve is set up properly, actual tuning of the valve can begin. Typically, this is done without fluid flow so a measure of confidence in the system can be gained prior to introducing propellants. A system behaving in a desired manner is essential to helping reduce propellant and testing costs.

The E-Complex has undertaken a significant effort to help reduce testing costs by modeling valve tuning in the DACS Lab. Successful modeling directly affects the customer's bottom line and helps to lower schedule impacts.

G. Loop time

The E-Complex PLC systems are fast, reliable, and respond quickly to changing variables when performing rocket engine or component tests. One measure of the PLC's speed is the PLC loop time. This is the time it takes a PLC to execute all of its code one time. Another important measure is the complete throughput time. This is the time it takes a signal to go from an input module to the PLC, process it, and send a signal from an output module to a final control element (valve).

The latest Allen Bradley Control Logix PLC in the E1 test facility is truly exceptional when performing these functions. While loop times of 20 milliseconds are common in the older Allen Bradley PLCs, the Control Logix PLC has a loop time of less than 25 microseconds. Complete throughput timing tests have shown this time to be roughly 60-70 milliseconds in the older PLCs while the Control Logix PLC is normally under 5 milliseconds. The Control Logix PLC uses I/O modules designed to take advantage of its speed.

H. Emergency Shutdown System (EMSD)

Each test stand employs a hardwired Emergency Shutdown System (EMSD) to address PLC failure or faults. The EMSD removes all power to the facility, STE and test article valves allowing them to travel to their failsafe positions. It can be activated by the large red mushroom button on the test conductor's console or automatically by loss of a PLC's watchdog timer.

At E1, safety considerations may not allow closure of two valves at the same time such as the propellant valves. This has been solved by a special circuit that allows slewing the closure rate of the valves. The EMSD at E2 currently employs four separately timed busses that remain energized until their timers expire. Power to the valves is removed in a set sequence depending on which bus they are connected. This timing system, however, does not take into account that a PLC fault will immediately de-energize any valves connected to that PLC's output channels. Therefore a slew circuit, similar to what is employed at test stand E1, is currently being implemented. The EMSD system at the E3 test stand is similar to E2 but the slew circuit is not currently being implemented.

VI. DACS Lab

The Data Acquisition and Control System Laboratory, as seen in Fig. 13, is a facility designed to provide an off-stand capability for developing data acquisition and control systems in support of the E-Complex. The laboratory's safe and controlled environment allows verification and development without impacting project schedules or compromising pre-existing test hardware, software, networks or configurations. It has been particularly useful in the identification and resolution of significant issues with equipment and configuration functionality prior to activation.

The laboratory has the resources for creating elements of a project's design package. Its servo valve control capability and personnel's expertise have been utilized to expedite mission critical valve integrity checks prior to field installation. The DACS Lab has also shown its usefulness when investigating and resolving Data Acquisition and Control Systems anomalies discovered during project activations and testing.



Figure 13. DACS Lab.

The DACS Lab has helped to eliminate facility downtime and test delays. In addition, it provides a place for hands-on training, qualifying spares, market evaluations, minor equipment repairs, and familiarization with data acquisition and controls equipment unique to the E-Complex test facilities. It has the ability to mimic systems found in the E-Complex. It contains a wide range of computer hardware, software, controller equipment, data acquisition recorders, signal conditioning equipment, digital electronic equipment, analog electronic equipment, and electronic test equipment. These resources are integrated into three general areas in the Lab: the Data Acquisition System (DAS), Control System, and a general maintenance area.

The DAS area is outfitted with a HSDAS System, a LSDAS System, a signal conditioning system, and a DAS control station. The two DAS systems are integrated into a patch panel interconnection arrangement that provides an easy interface to the signal conditioning system or external equipment. The DAS systems are networked with a DAS control station that automates the DAS control and configuration functions. This DAS area produces an environment for end-to-end or single point development and verification of DAS systems identical to the field. In

addition, actual software and equipment from the E-Complex can be integrated into the DAS system for a versatile test bed.

The Control System area, as shown in Fig. 14, is comprised of a subscale version of a single E1 test cell PLC control system, a real input/output (I/O) interface system, a control operation station, an input/output software simulation system, a control software development station, a controller trainer system, a control checkout cart, and a servo-valve control system.

The E1 test cell PLC control system is composed of PLCs identical to the field. It is tied into the real input/output interface system through an expansive interconnection scheme. This provides the ability to develop and debug E1 control logic programs, verify controller I/O, and verify controller configurations. I/O conflicts can be avoided without disturbing the test facility. This system is also networked into the control operation station producing a fully functional control system. The control operation station adds the ability to incorporate the operator's interface. The interaction between the operator's interface program(s) with the controller's logic program(s) can be debugged and their functionality verified.

The control software development station provides the means for developing the operator's interface program. It also possesses the ability to examine the effects of incorporating the new operator's interface program into pre-existing facility programs. The I/O software simulation system can be addressed by the operator's interface programming to simulate any I/O external to the controllers such as inputs read from the DAS system. All of these systems are important tools for the creation of a project's software development package.



Figure 14. DACS Laboratory Control System Area.

The controller trainer system is comprised of two small controllers and I/O panels that are ideal for small lab projects and experimentation. In addition to these, the DACS Lab has a control checkout cart that serves as a fully contained mobile control unit capable of interconnecting with controller I/O modules. The cart provides the ability to interject real I/O signals into the Lab's control systems as well as any control system in the E-Complex. It is a helpful tool for troubleshooting control hardware and systems.

The Control System area also contains a servo-valve control system. This system is used to support servo-valve control issues such as valve leaks and valve high-pressure certification. The Control System area possesses the flexibility for development, experimentation, and operational verification of control systems in a safe environment without risk to operational facilities.

The maintenance area is comprised of a workbench station and a media center station which is used to accomplish small miscellaneous tasks and help maintain the lab. For instance, the workbench station is used for simple equipment modification, test cable assembly, and minor equipment repairs. The media center station is used for electronic documentation storage, media transfer, and a print server.

Each of these three work areas are able to operate as a stand-alone unit or work in conjunction with each other, creating a flexible yet functional tool.

VII. Conclusion

The DACS of the E-Complex are extremely complex systems whose sole purpose is to provide accurate, reliable data to a myriad of customers in the safest possible manner. DACS enhancements are continually being made to improve automation and to integrate new technologies without compromising data integrity and reliability. With each step forward, the DACS of the E-Complex stand ready to serve for missions to the moon, to Mars and beyond.

Acknowledgments

M. S. Hughes would like to thank his talented co-authors and knowledgeable co-workers including immediate supervisors, especially Dr. Rick Rauch, for educating him and helping make this paper a reality. Their timely inputs, patience and technical insight were invaluable in its creation and success.

References

- ¹Racal Recorders LTD, *Storeplex Installation*, 5th Issue, Racal Technical Publications, Hants, England, 1997, pp. 1-35.
- ²Racal Recorders LTD, *Storeplex Operation, Addendum A, Analogue Channel Module SPA01C*, 2nd Issue, Racal Technical Publications, Hants, England, 1994, pp. 1,2,3,7.
- ³NASA/VA00 Propulsion Test Directorate, *X-33 A-1 High Speed Data Acquisition and Processing System (HSDAS/ HSDPS) Acceptance Testing and Certification Plan*, Rev. B, Stennis Space Center, MS, 1998, pp. 4,5.